



# TECHNIC

42000



1



2



3



4



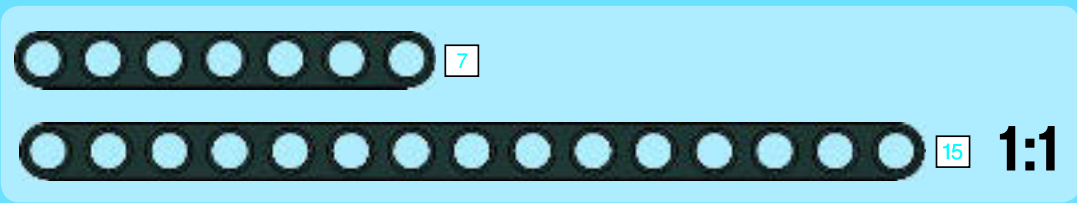
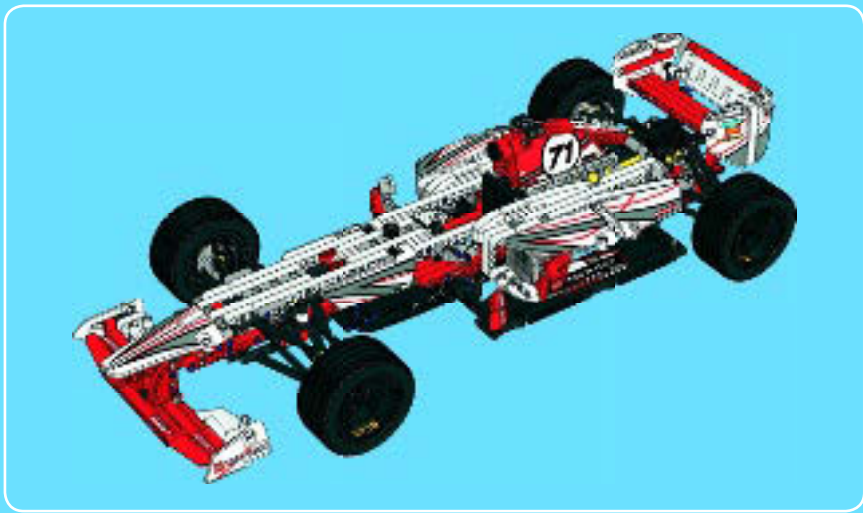

1

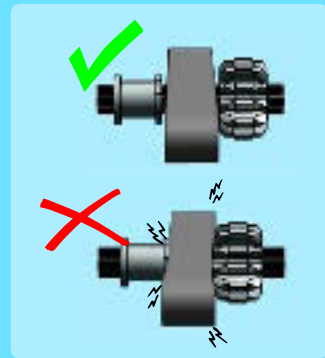
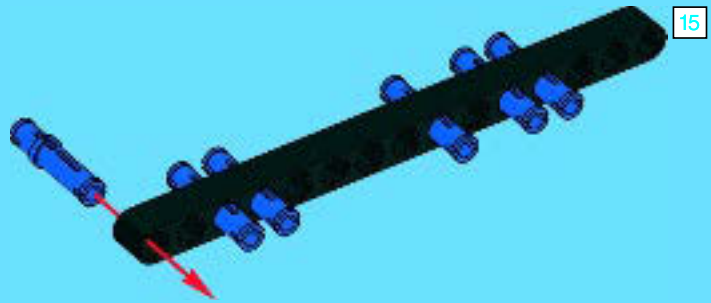

2

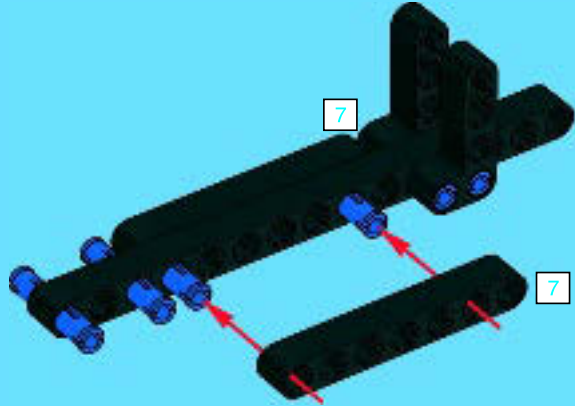



3

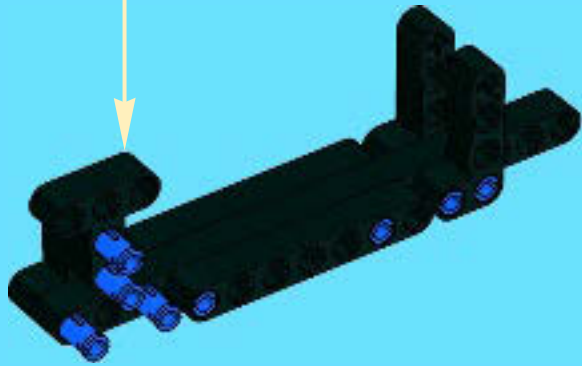
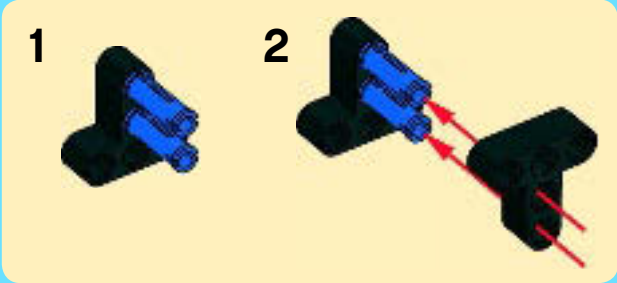

4

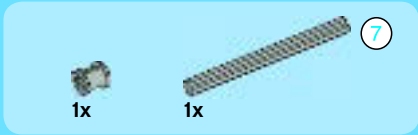
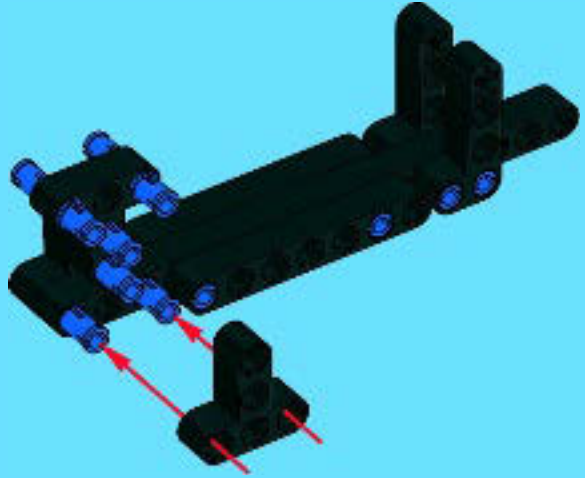

5

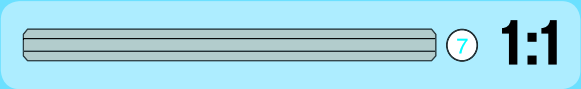
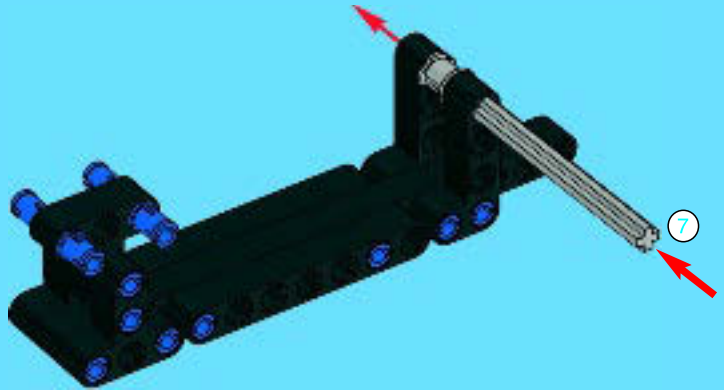

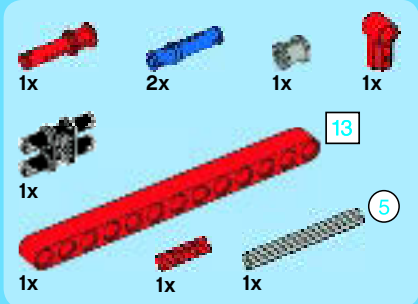

# 6

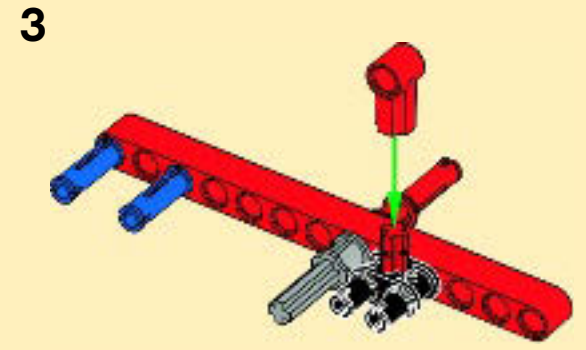
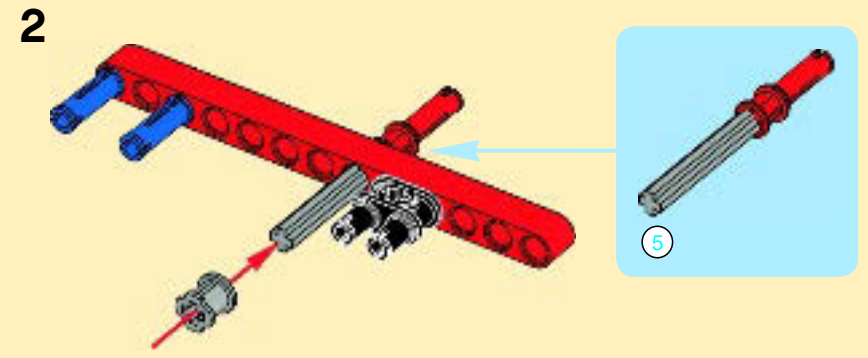
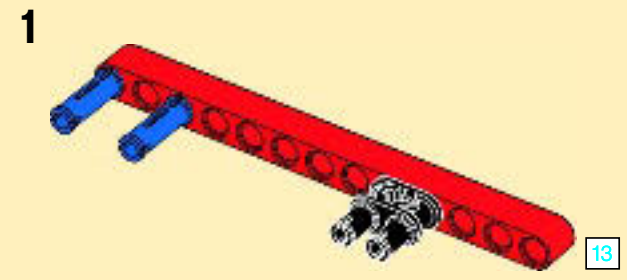
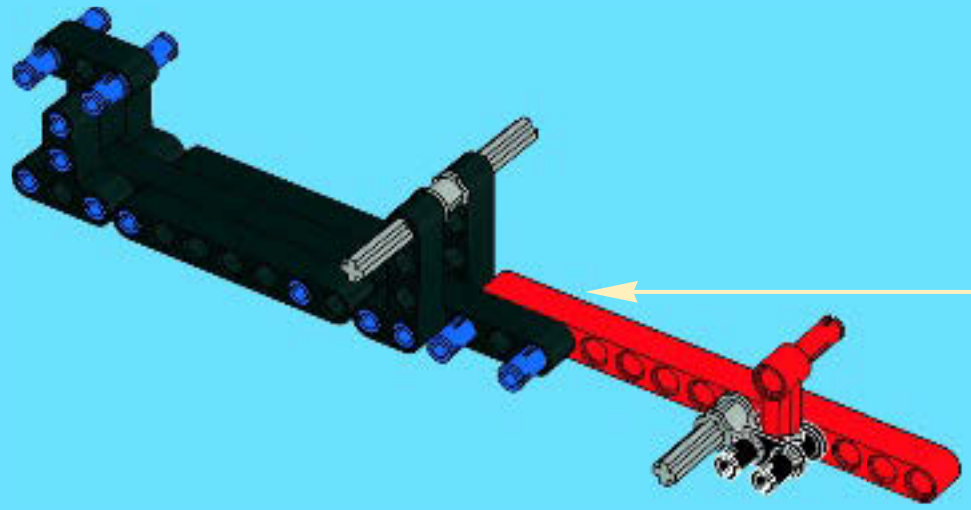



7

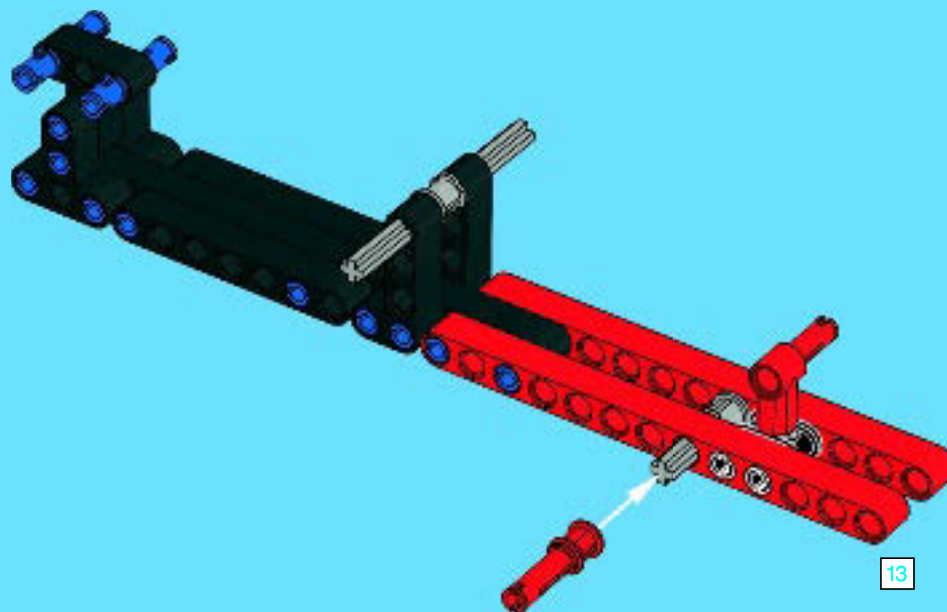
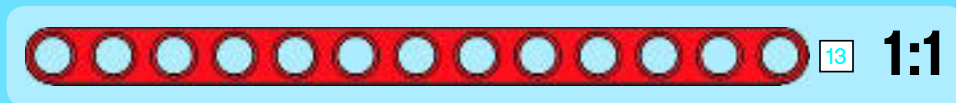

8

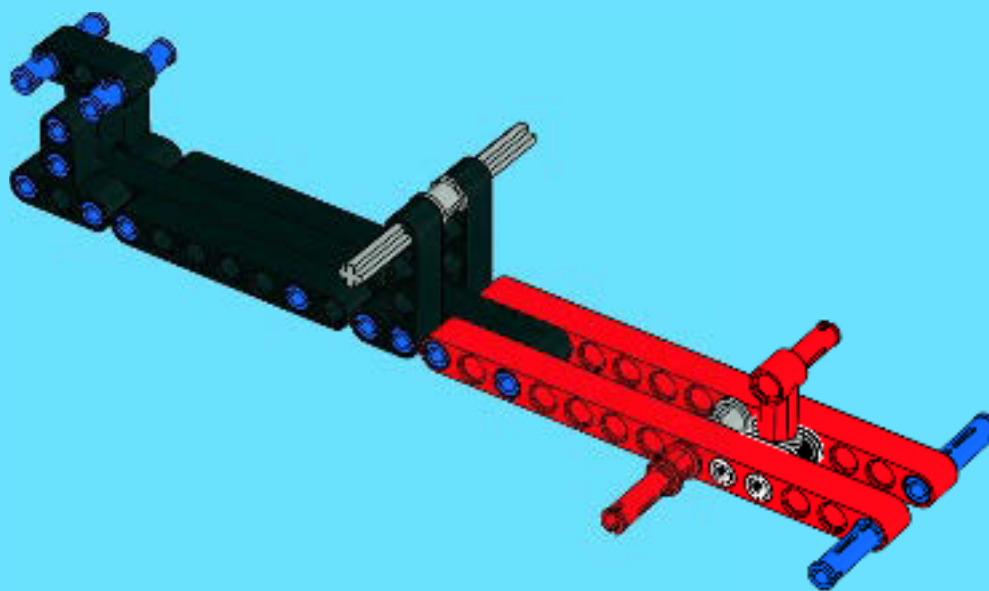

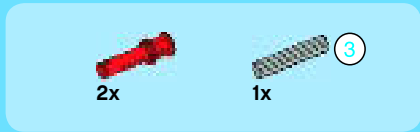
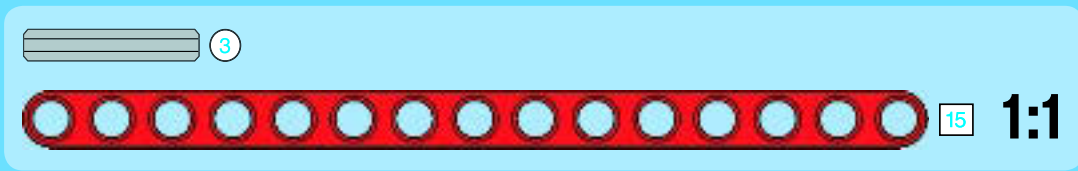

1

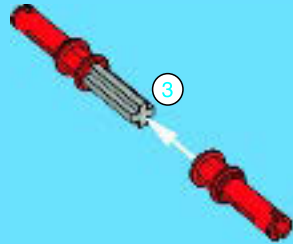

2

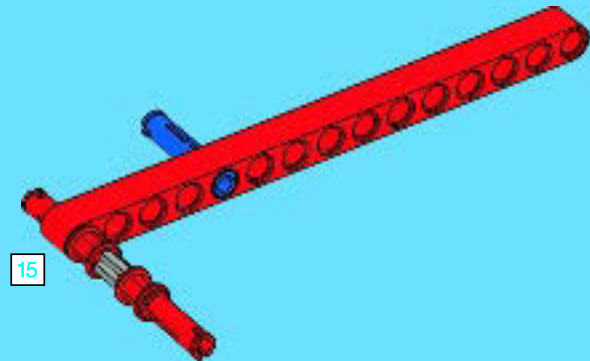

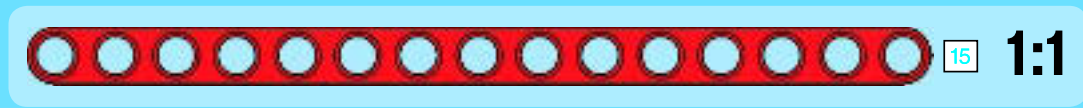

3

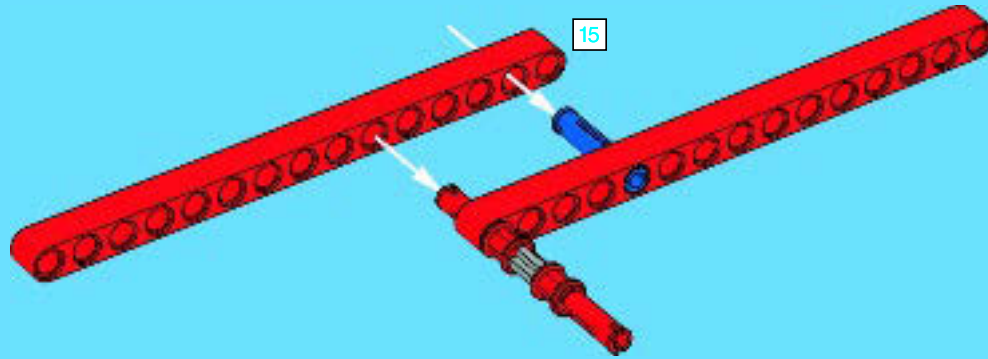

4

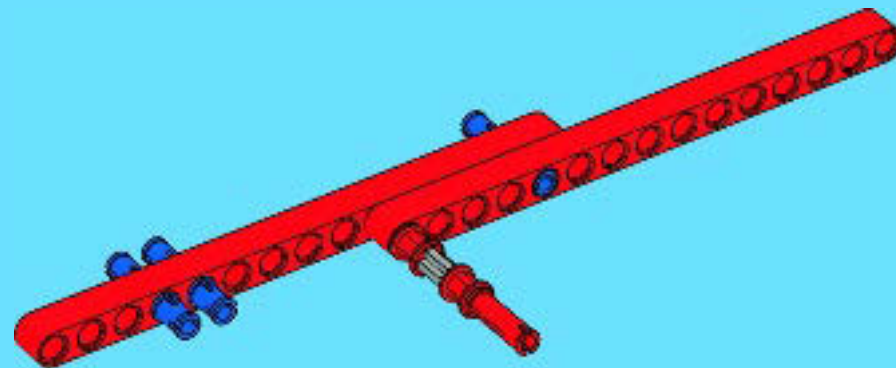





5

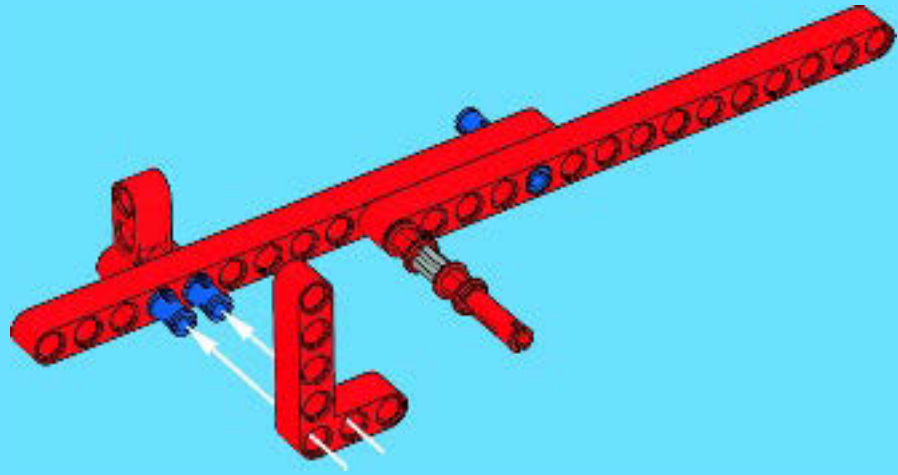

9

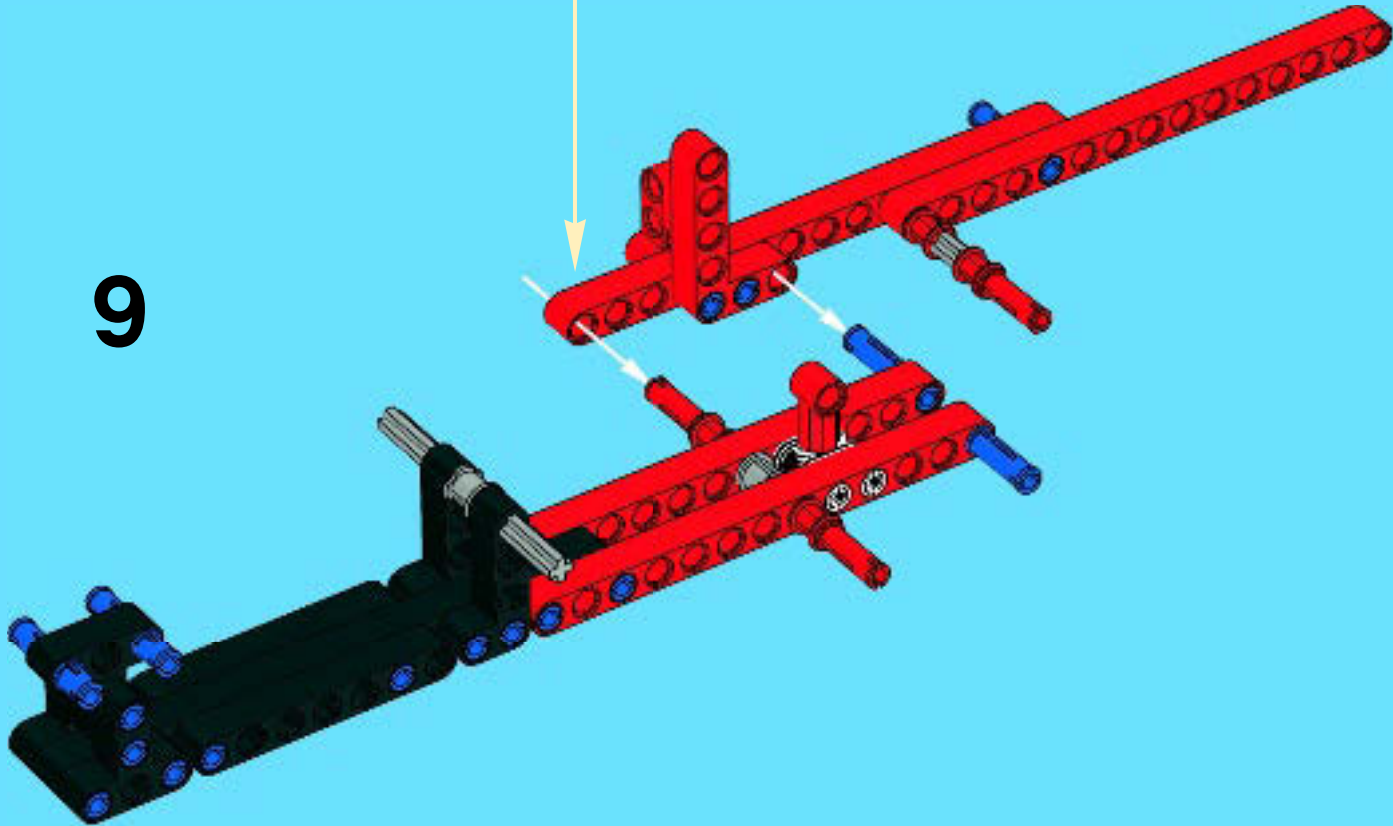

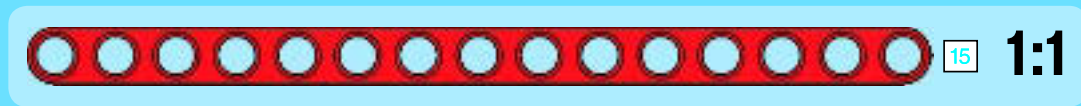

10

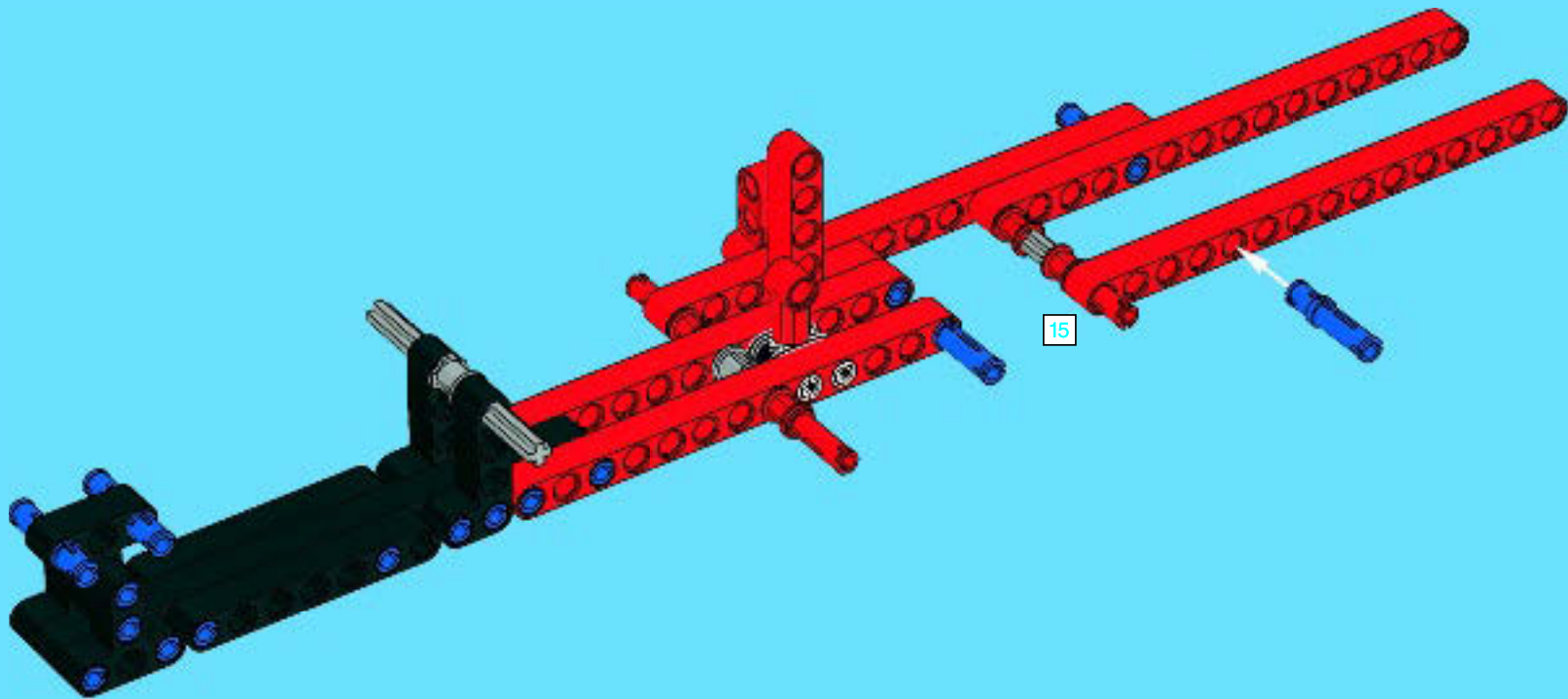

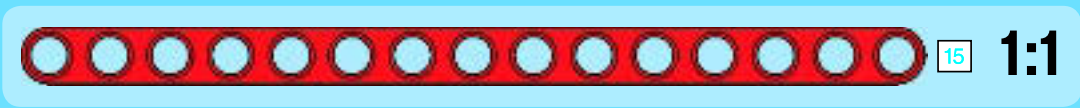
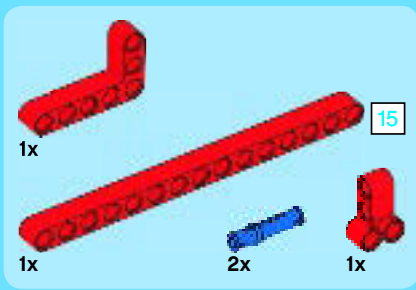

# 11

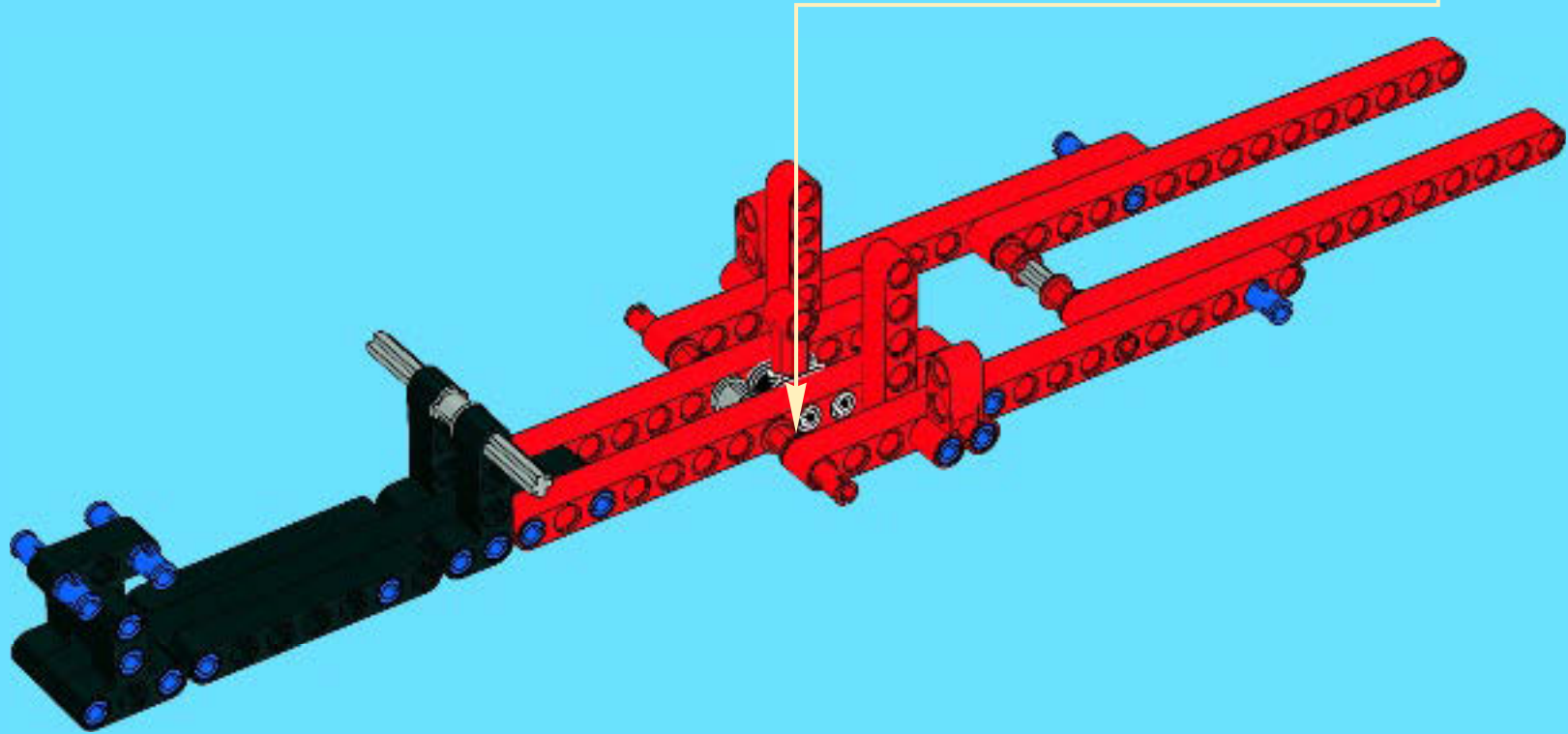
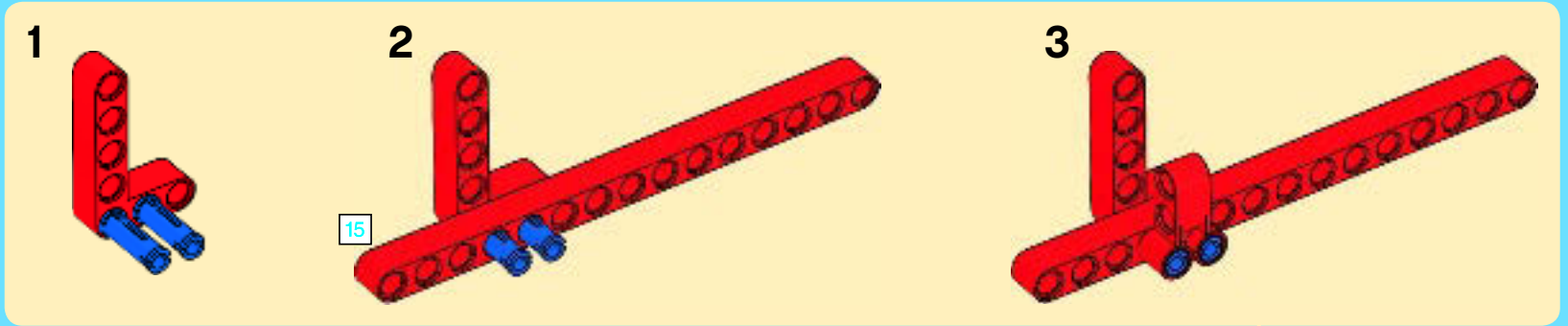



2x

# 12

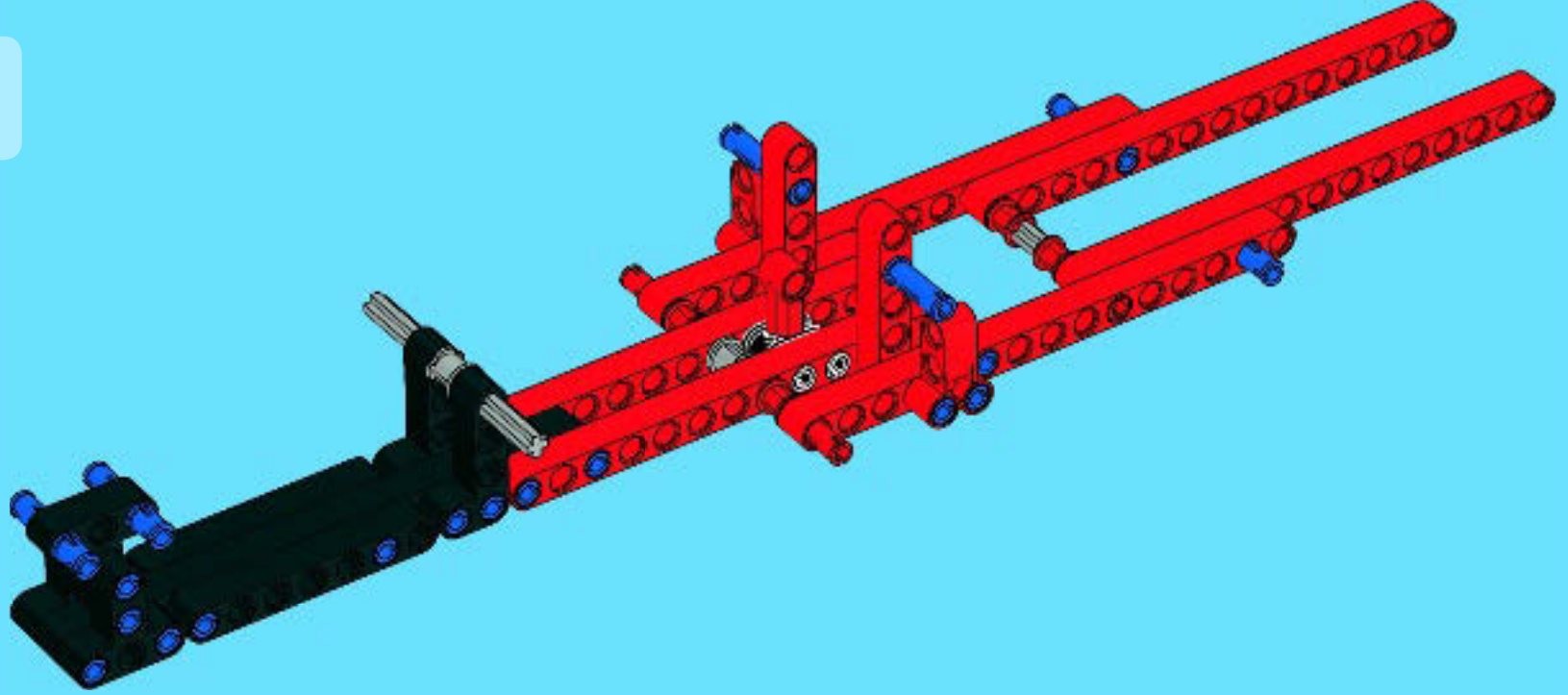

4x



4x

# 13

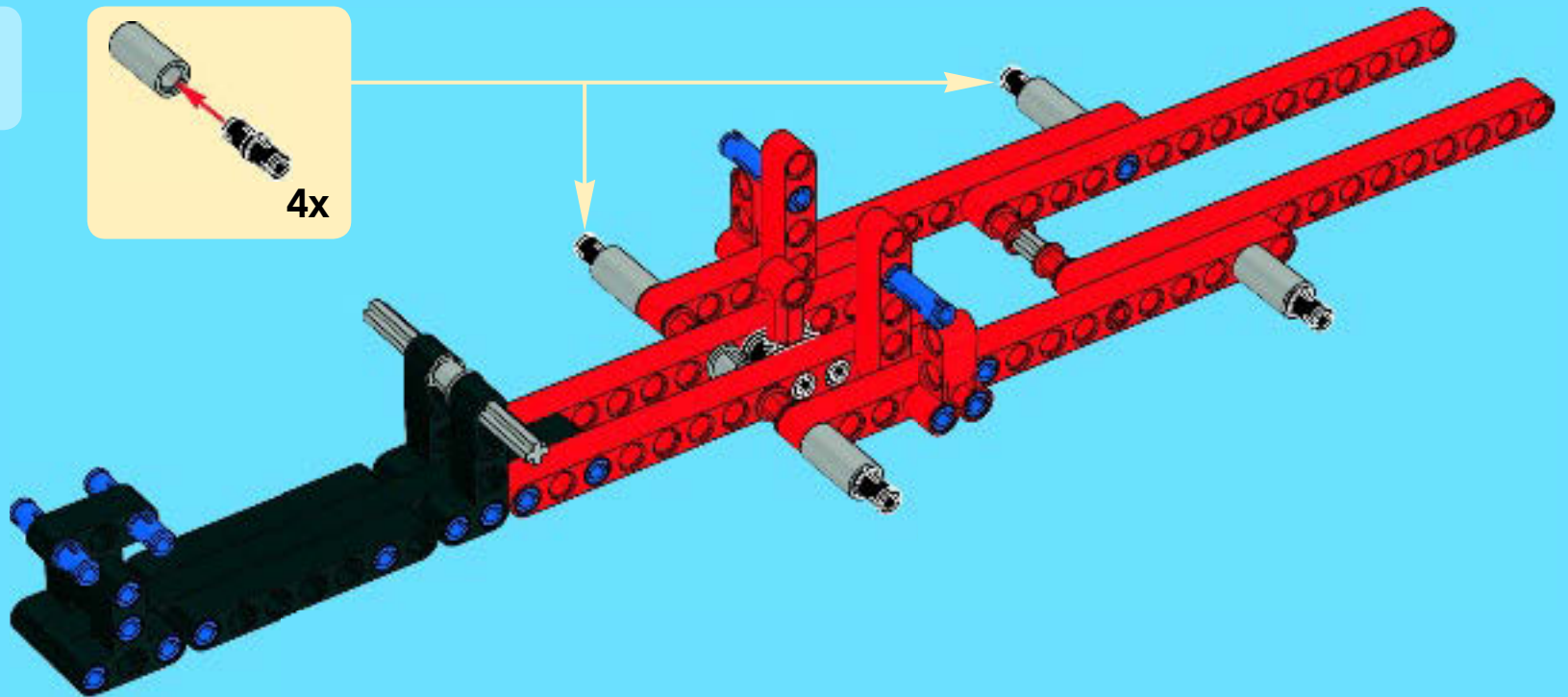
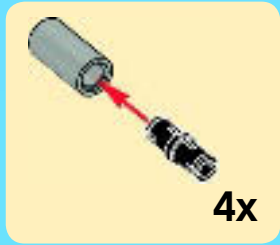



1

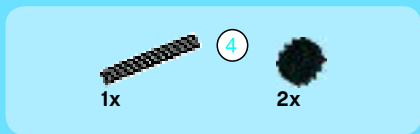
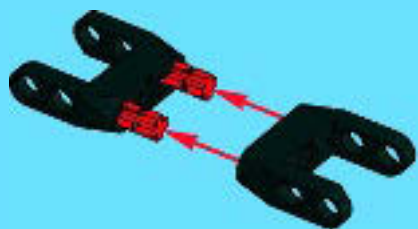

2

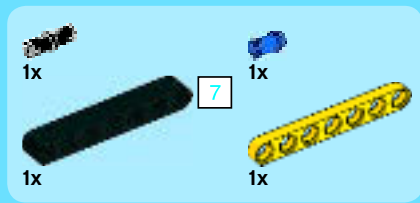

3

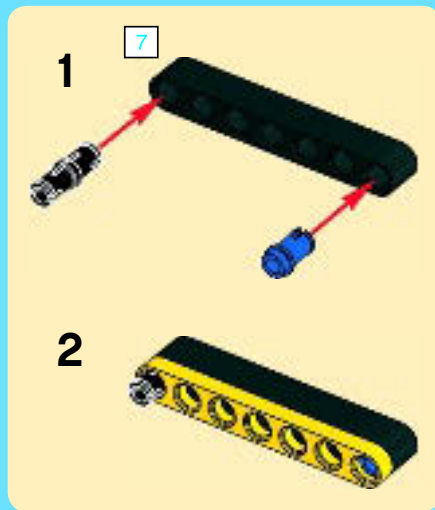

2

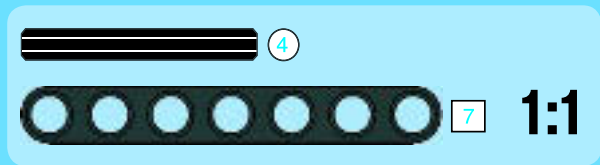

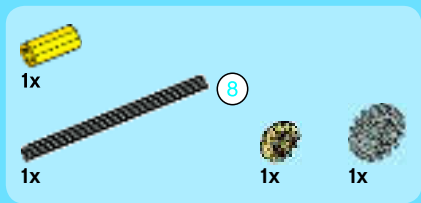

4

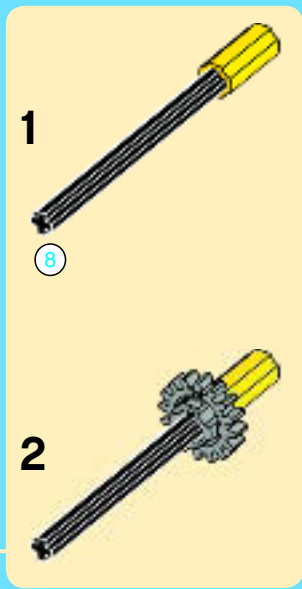
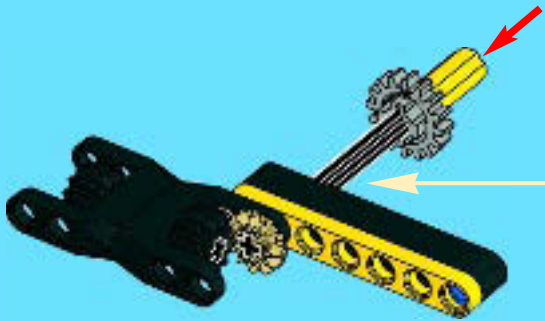

5

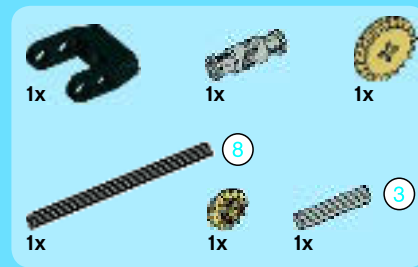
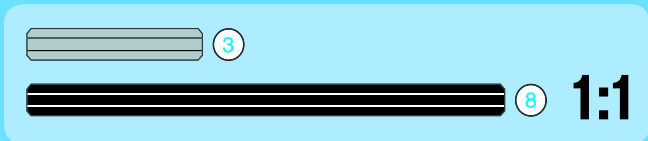
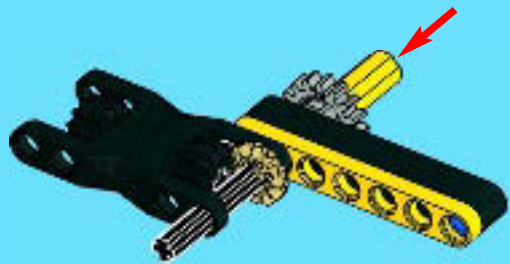

6

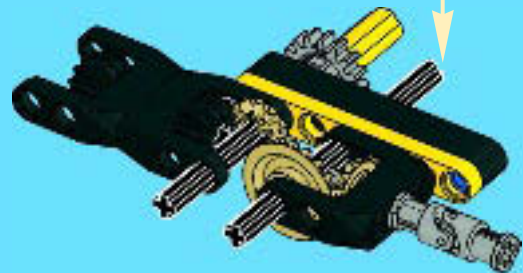
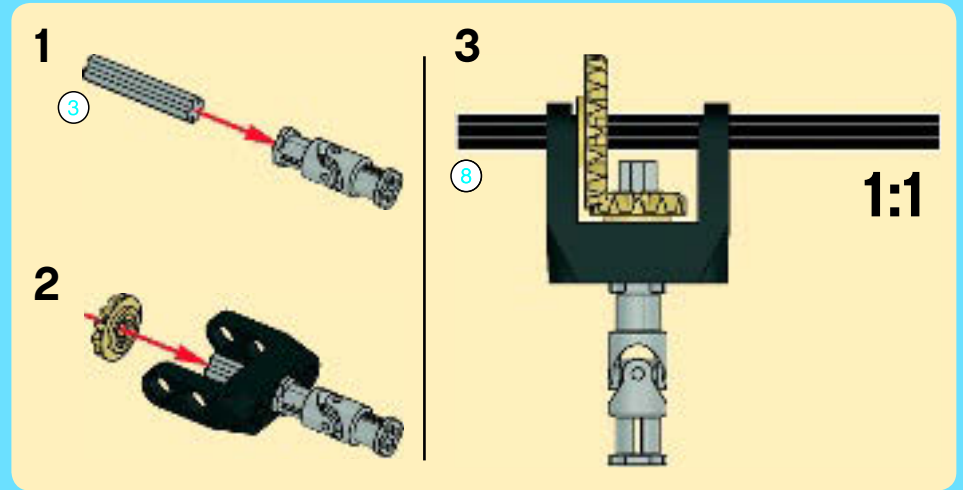



7

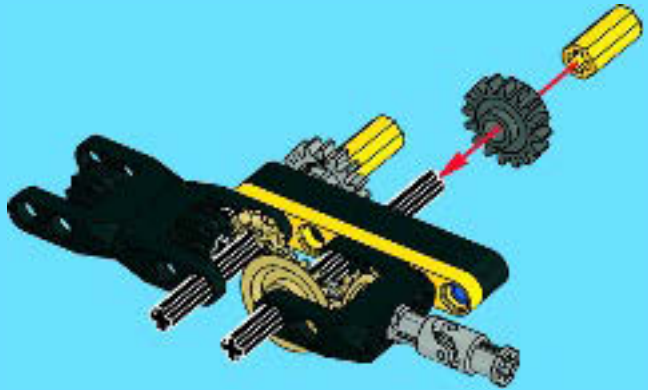

8

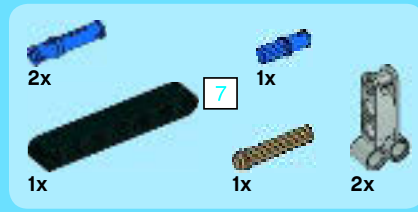
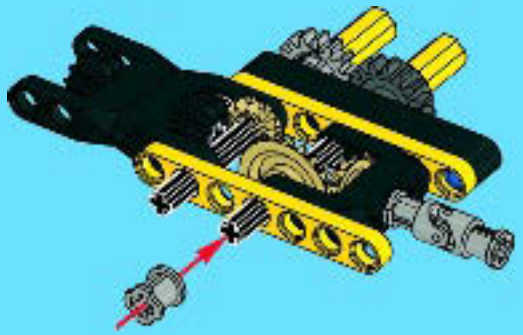

9

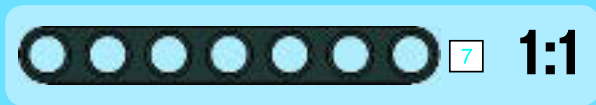
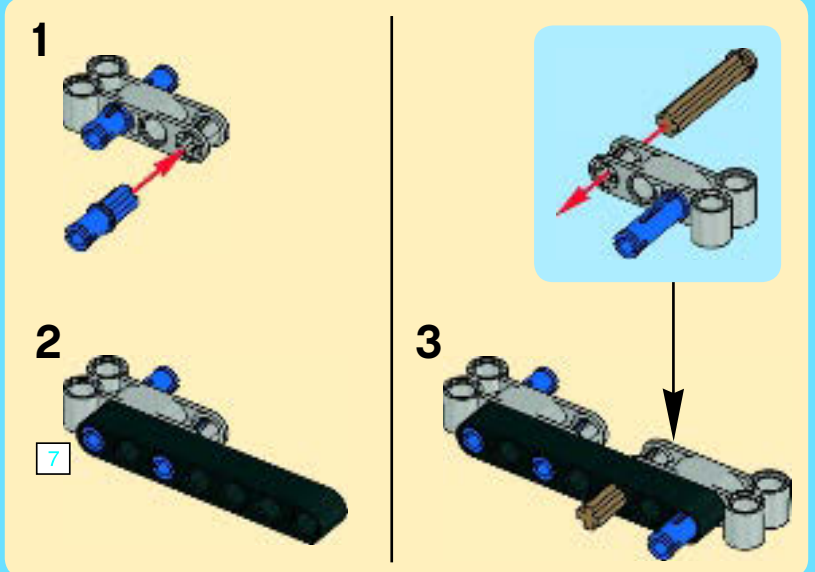

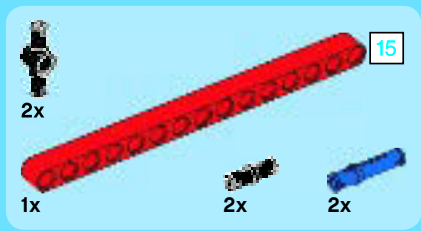

10

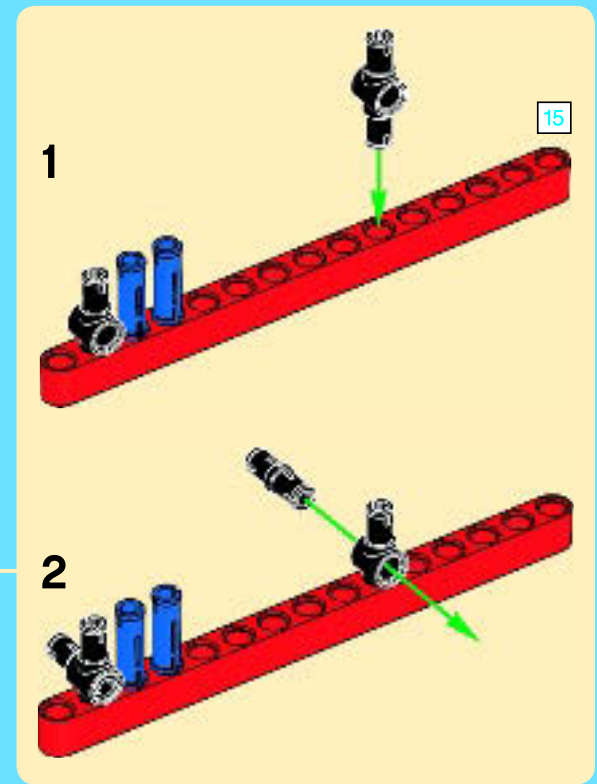
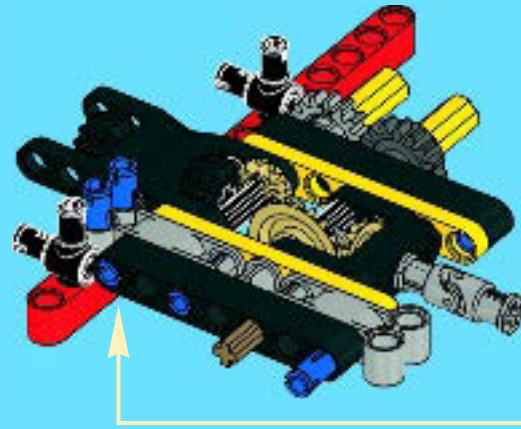

11

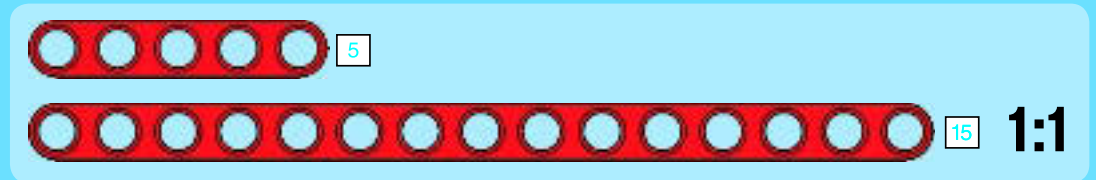
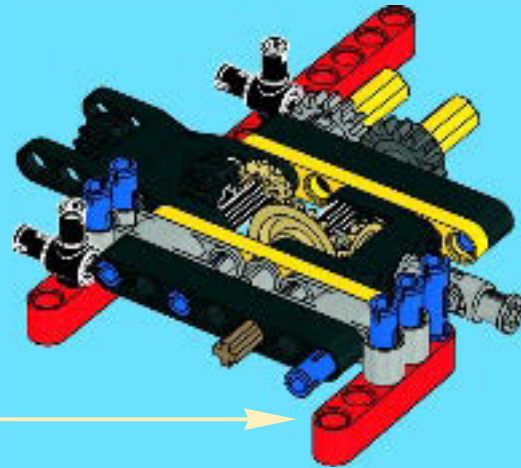
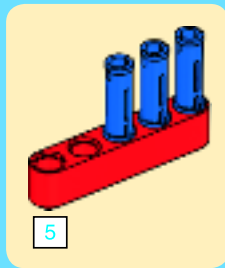



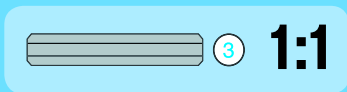
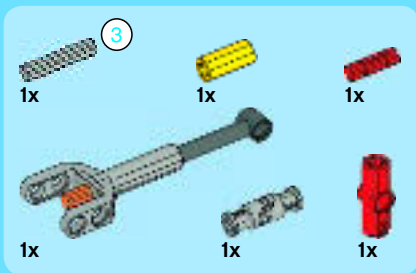

12

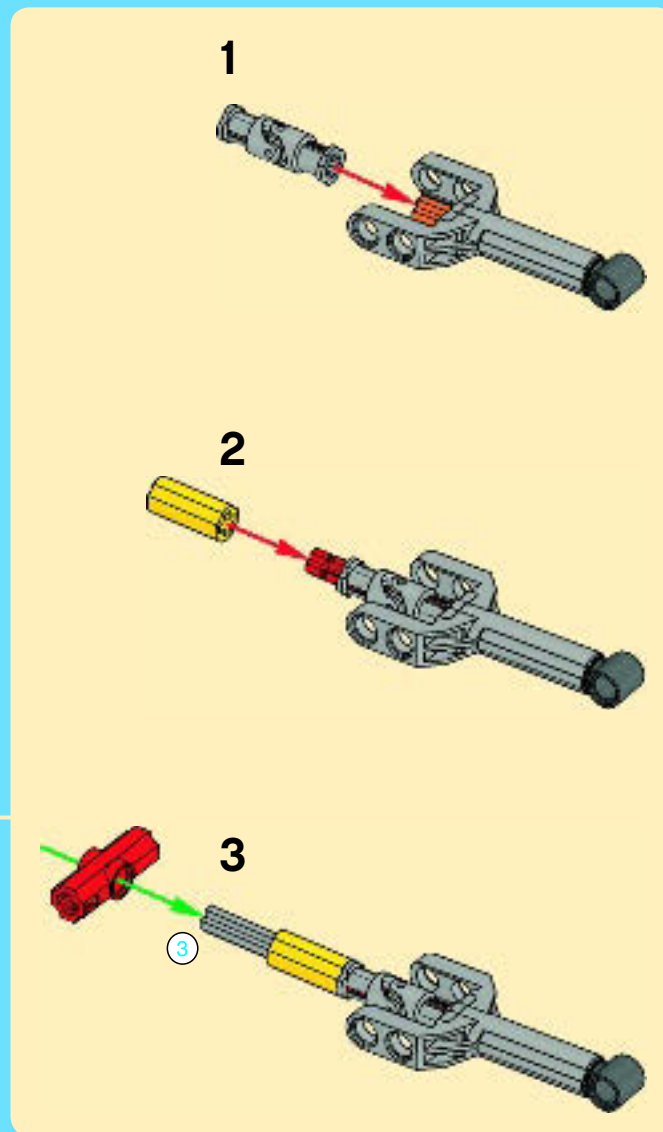
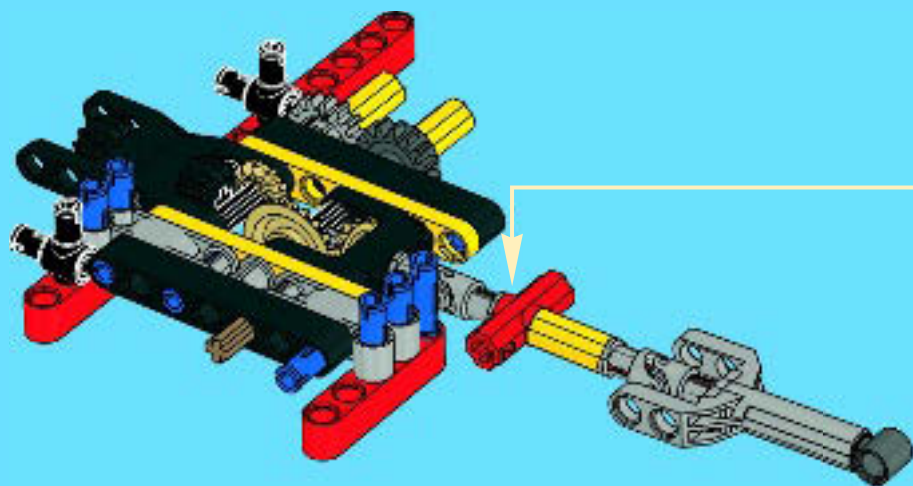



2x



2x

4



4

1:1

# 14

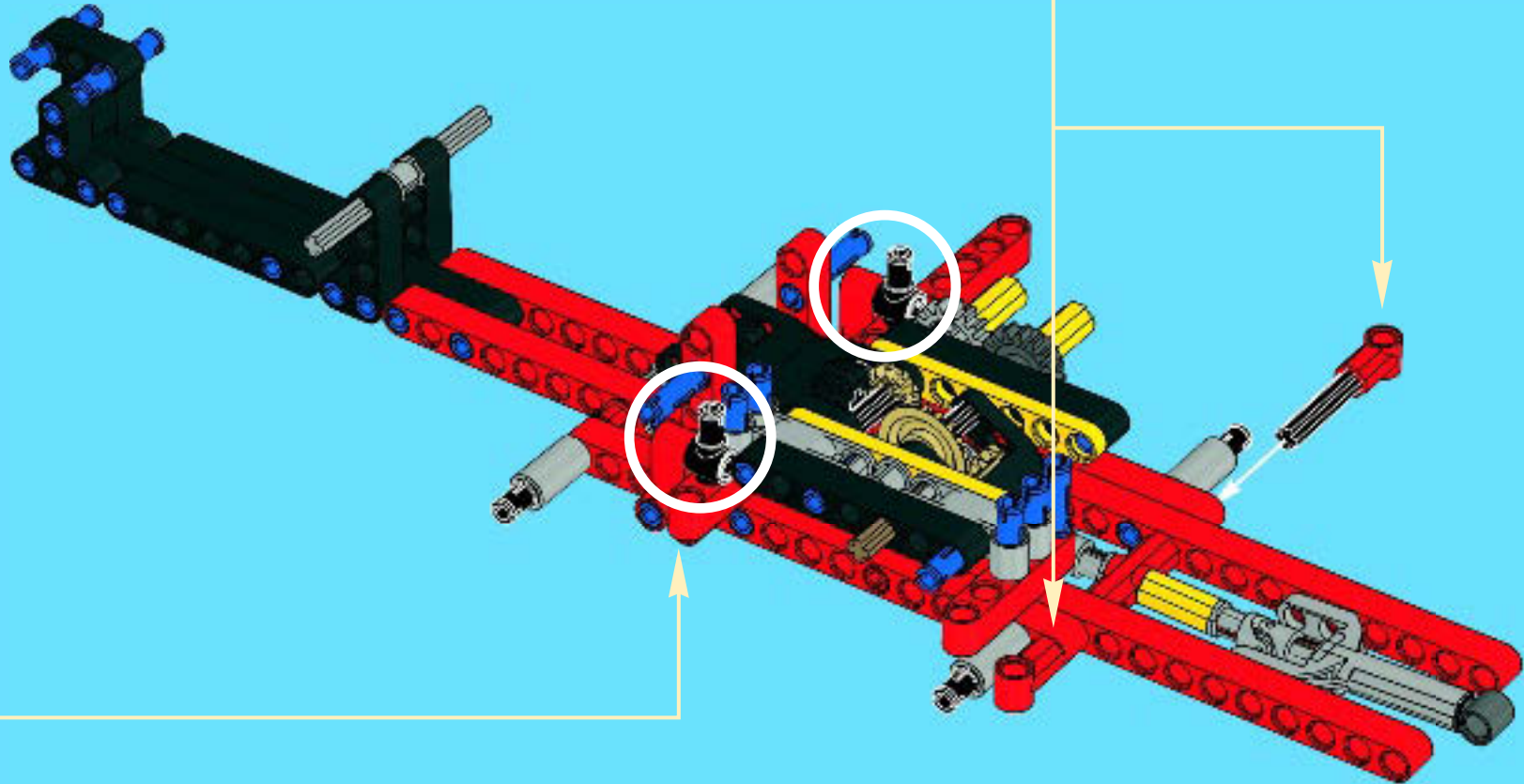
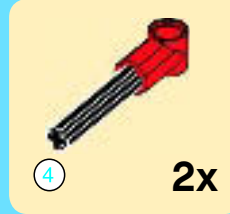



2x

# 15

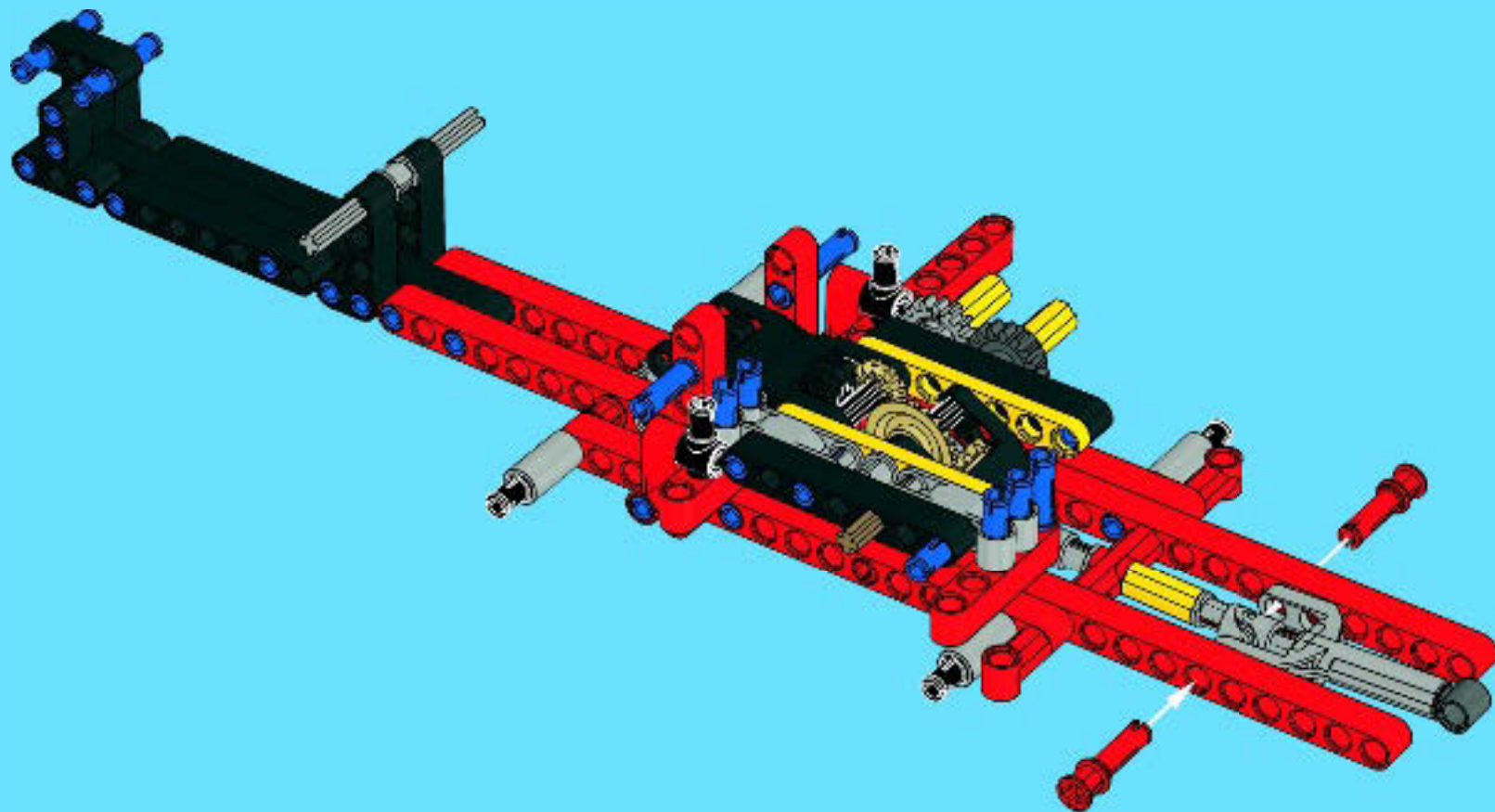

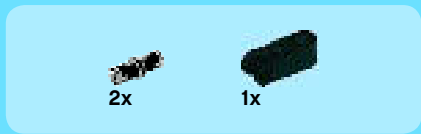
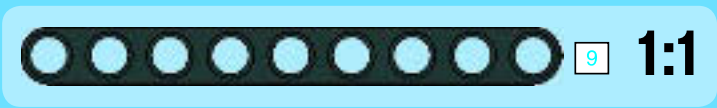

1



2



3

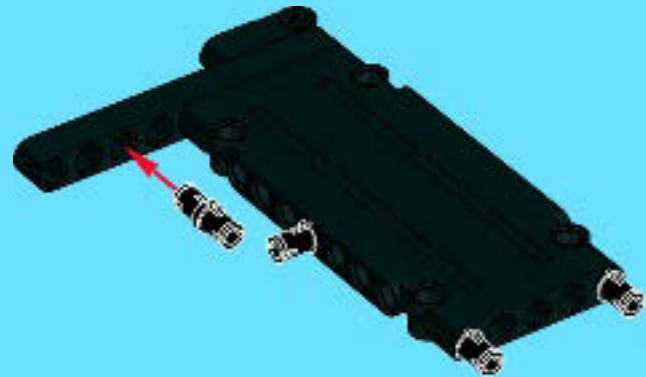

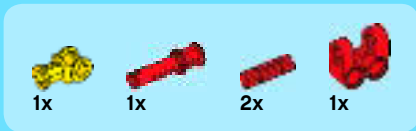

4

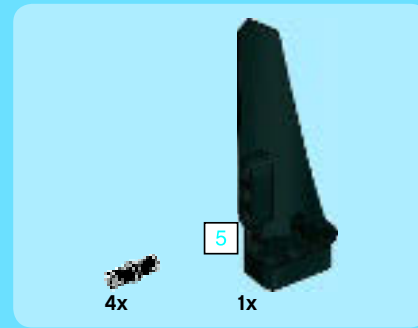
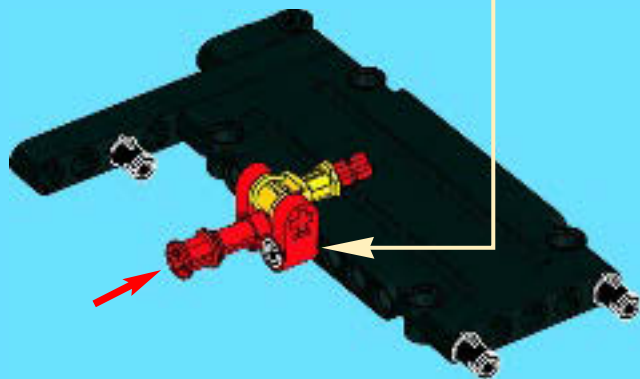
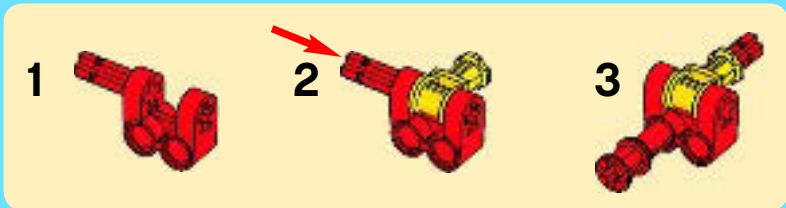

5

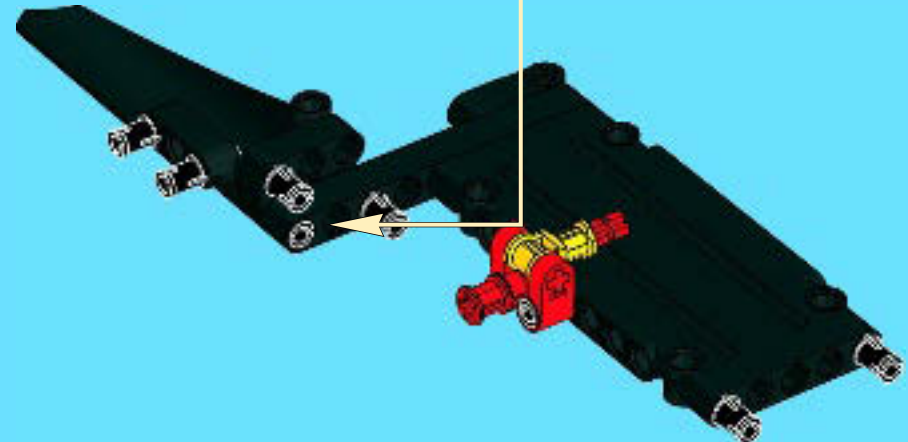
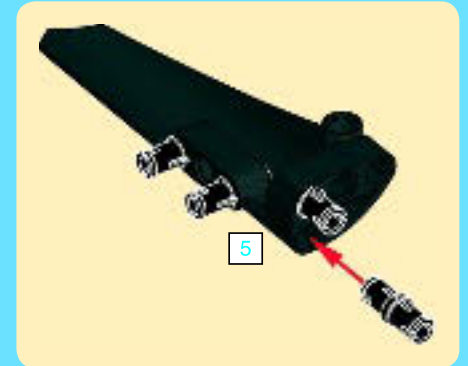



6

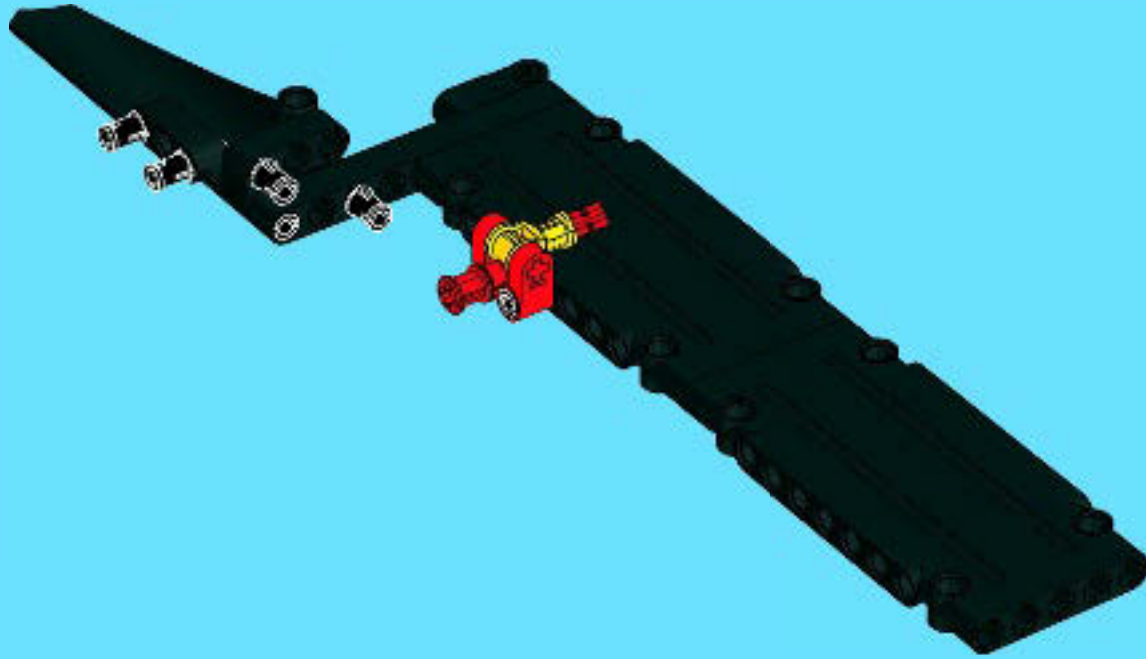

16

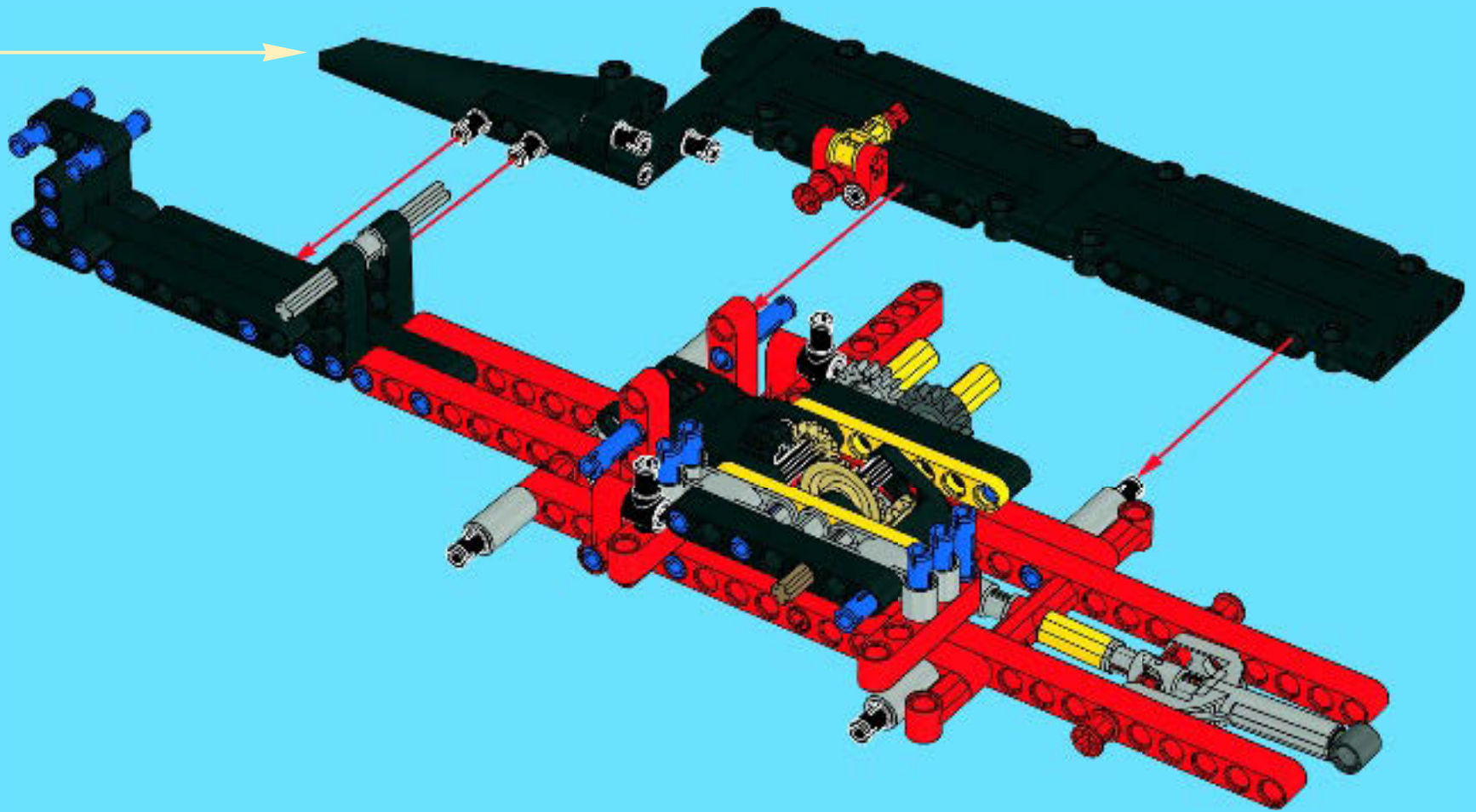

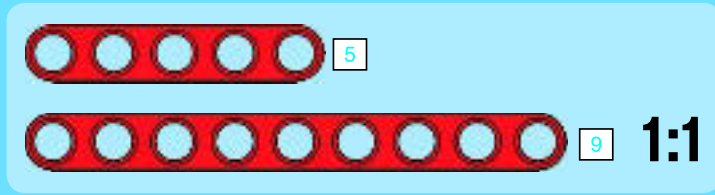
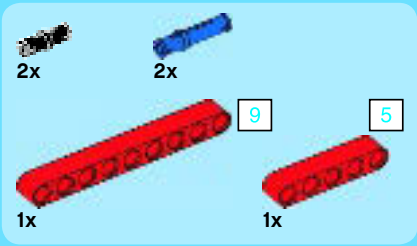

17

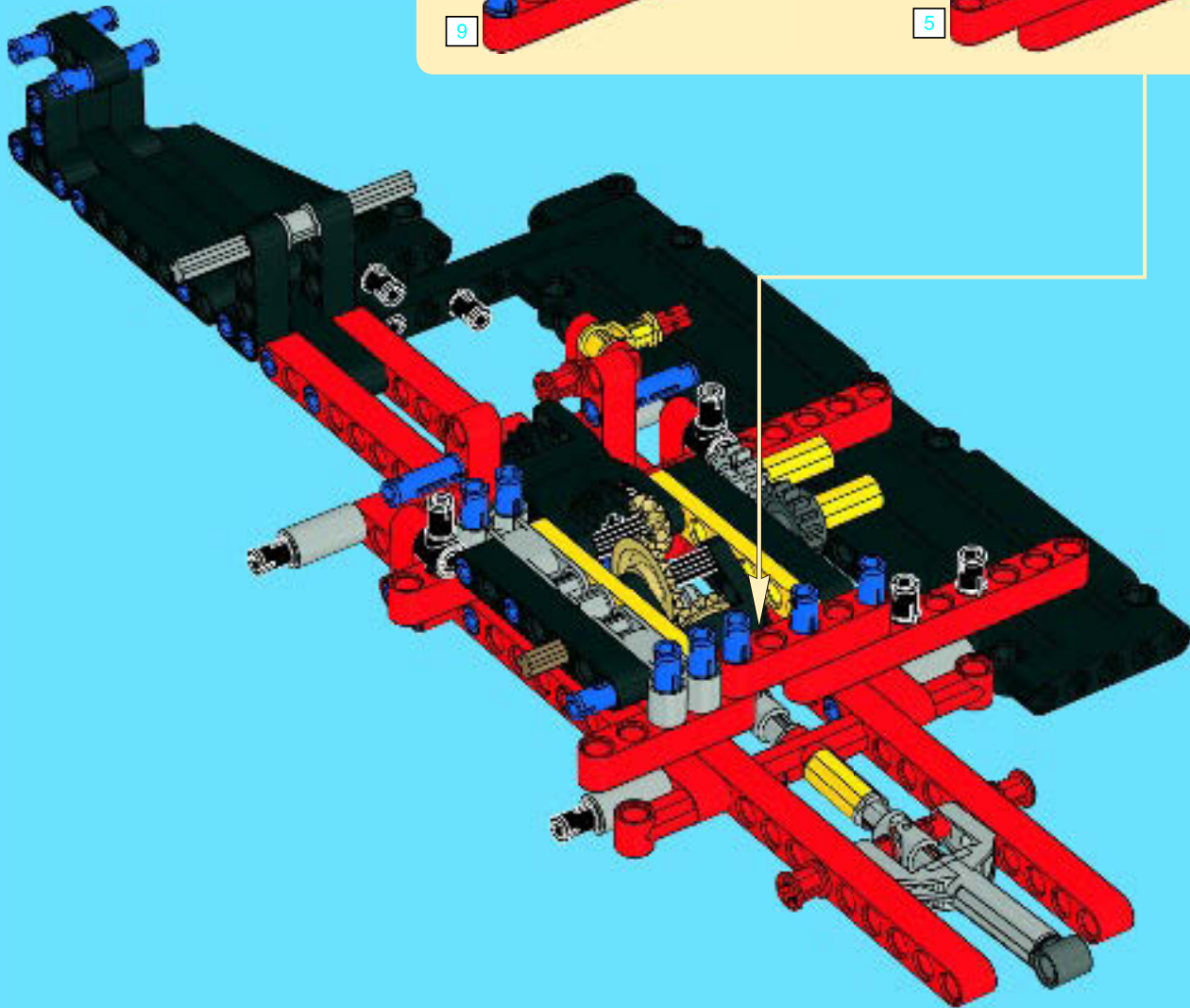
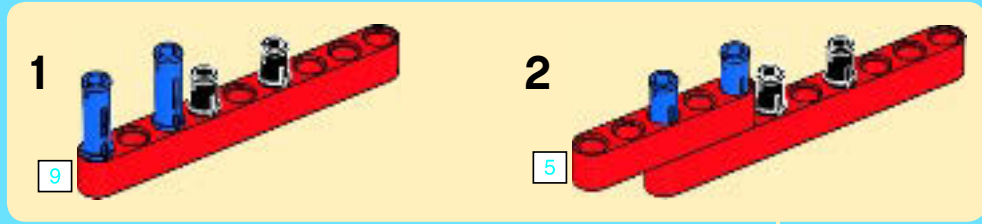





18

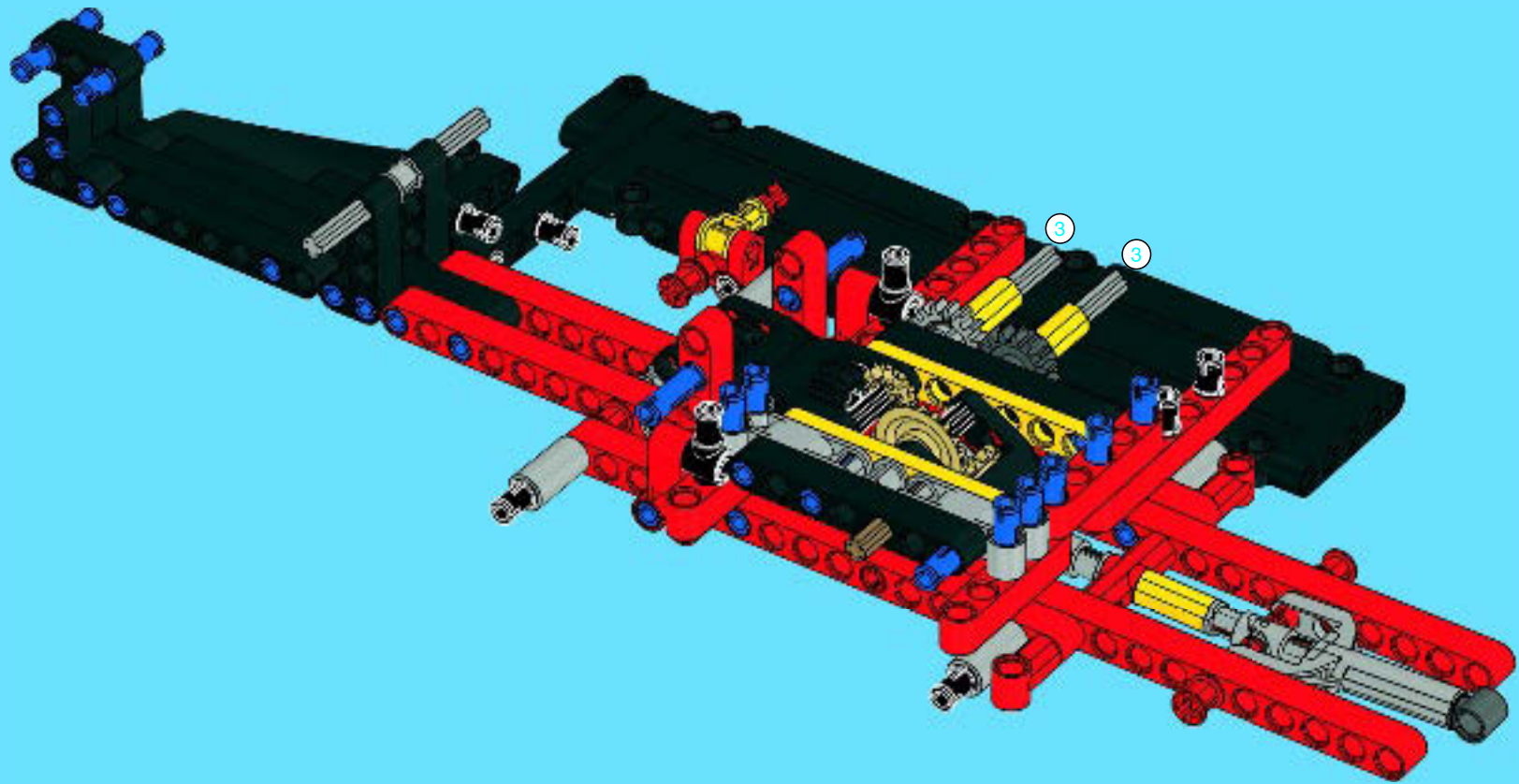



1x



1x

# 19

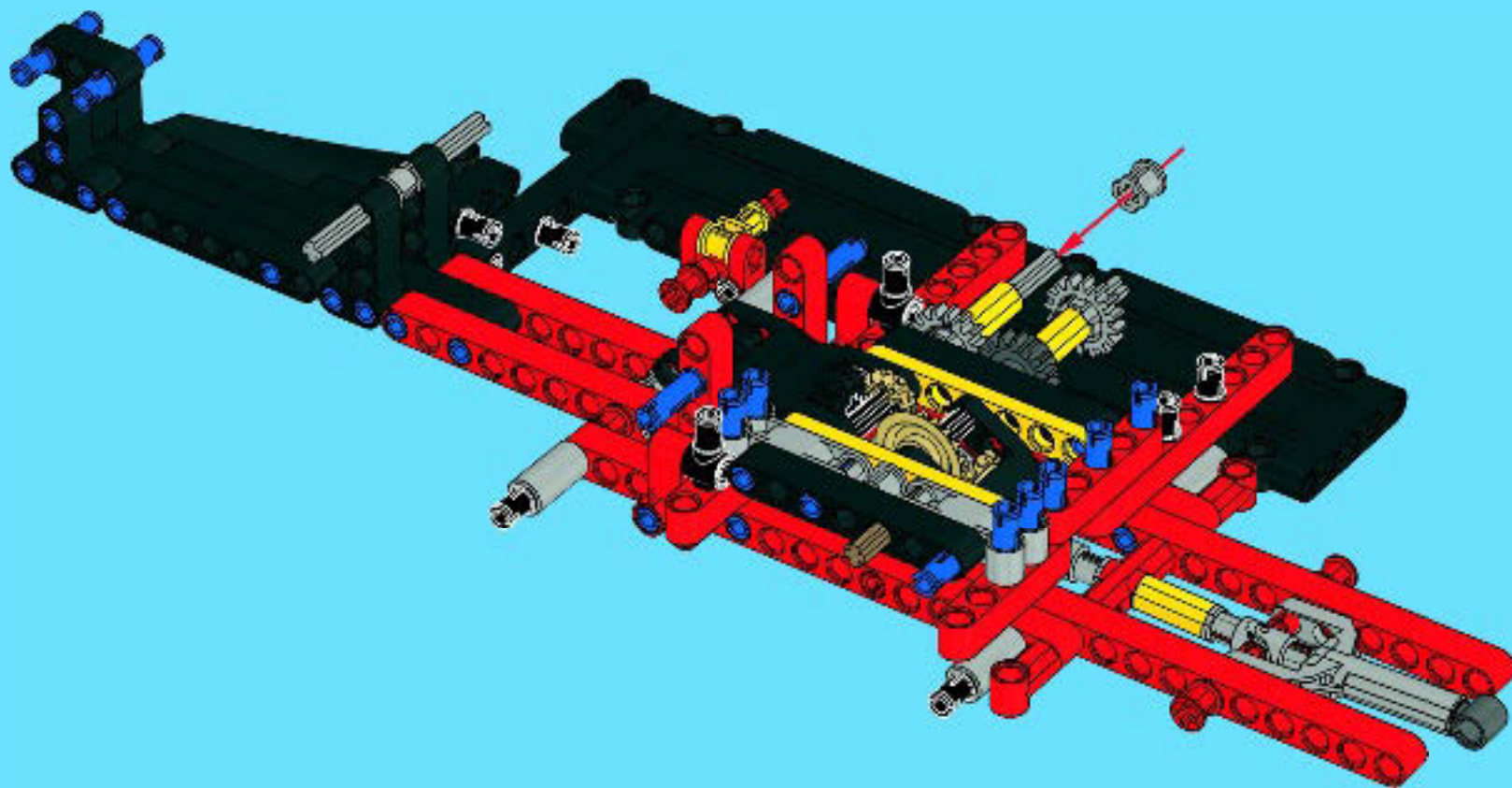

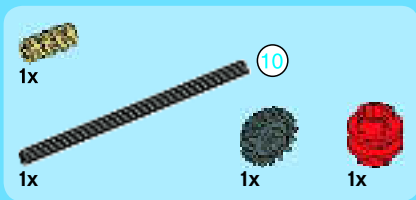

20

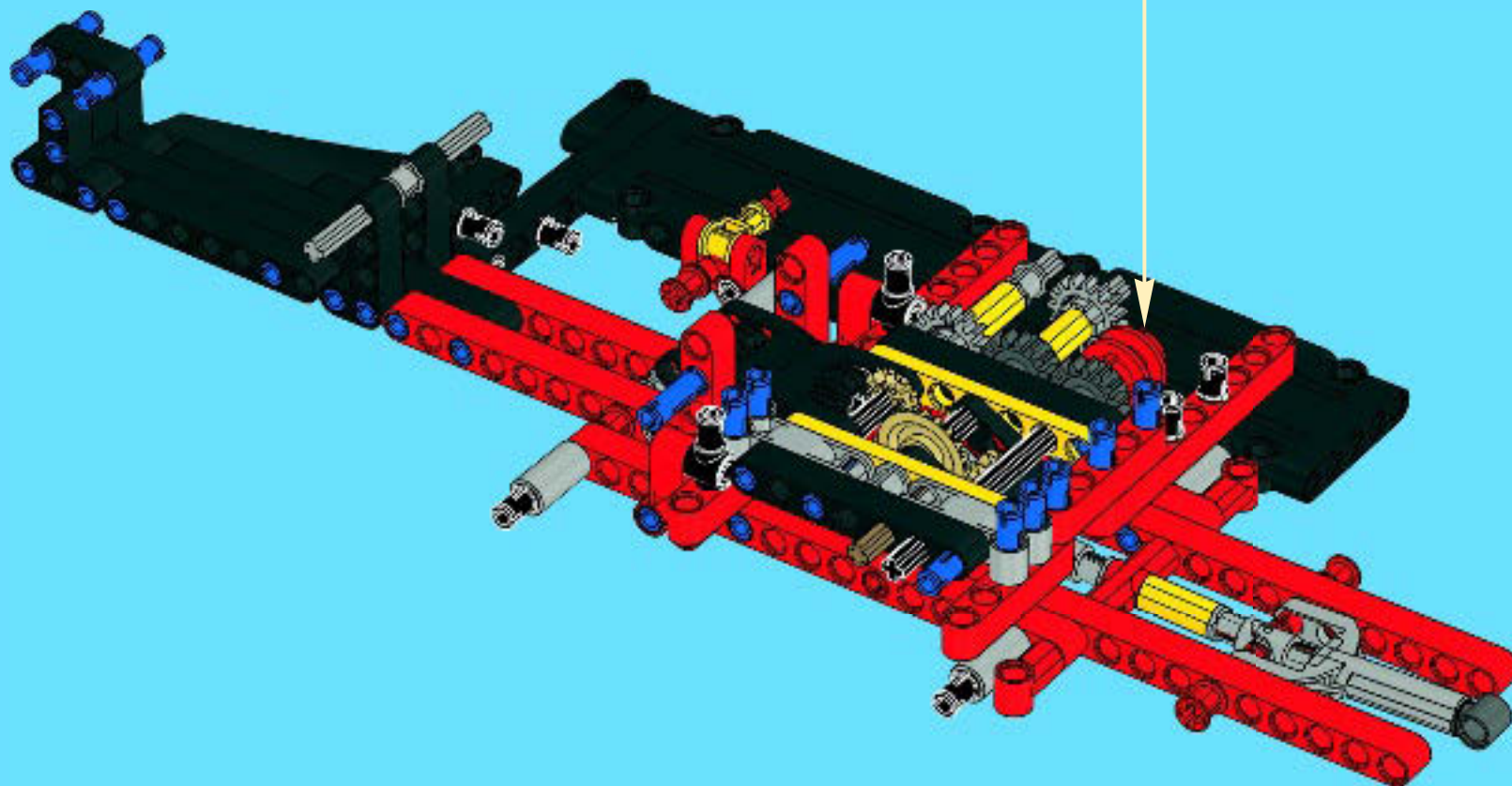
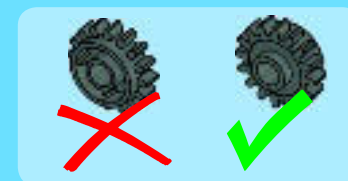
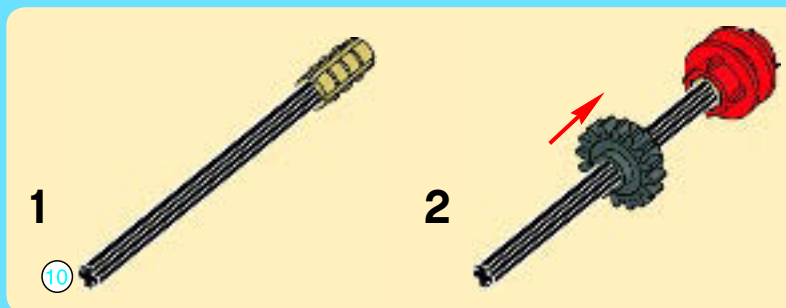

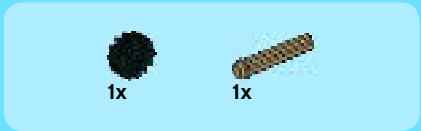

1



2

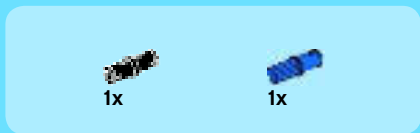
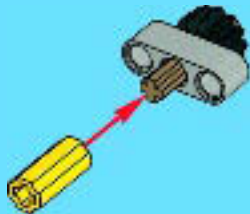

3



4

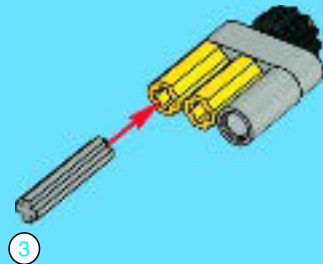
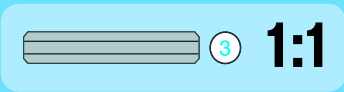

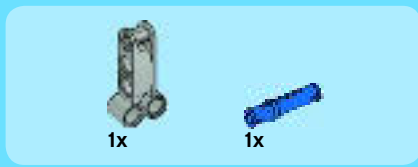

5

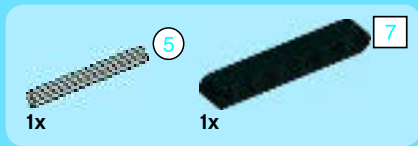

6

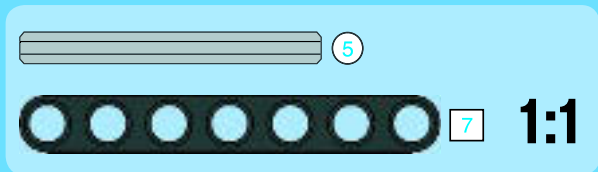
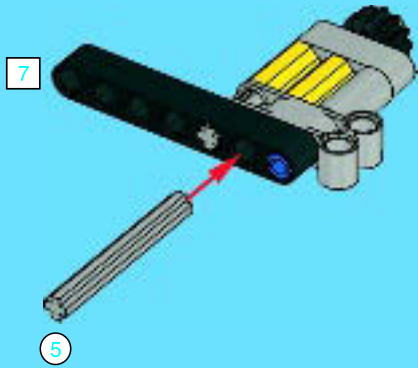

7

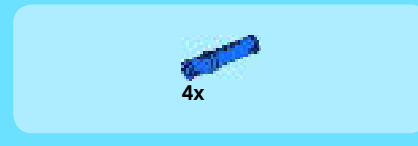
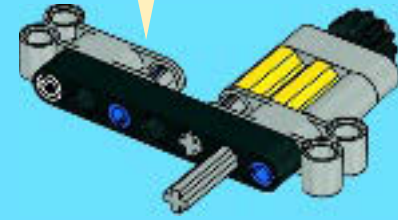
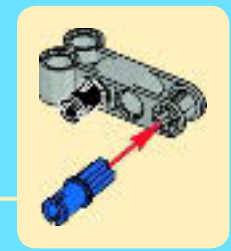

8

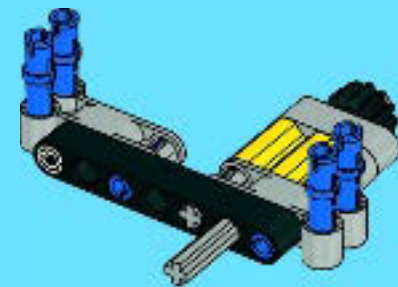



1x

9

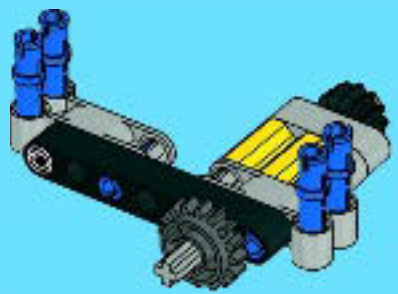
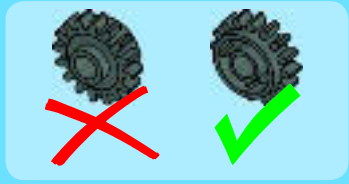

21

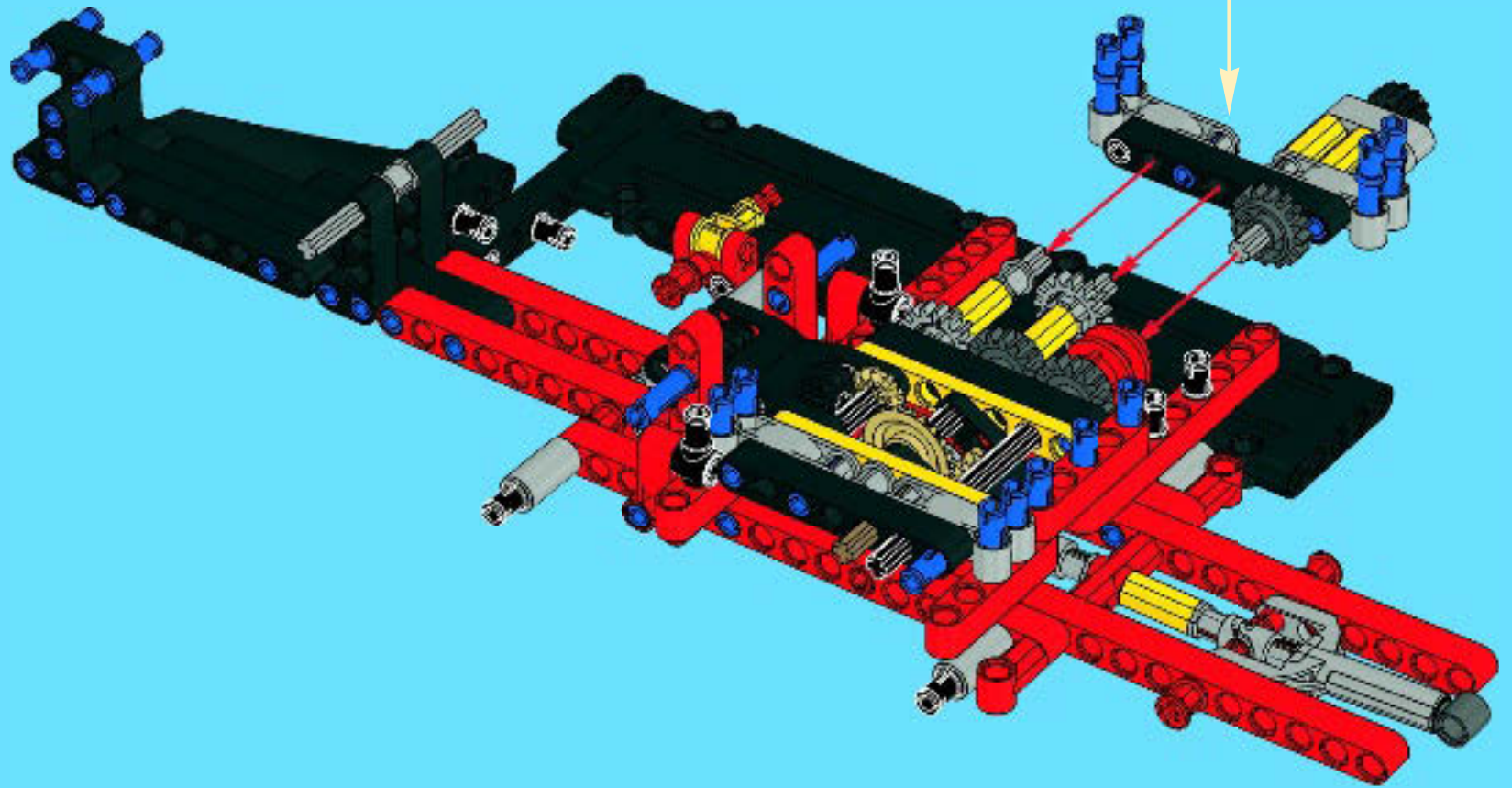

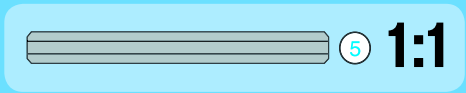
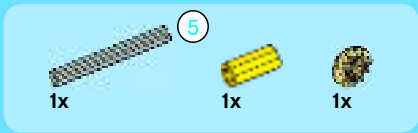

22

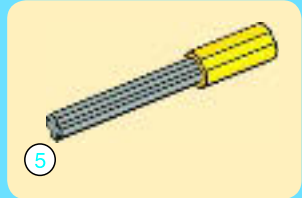
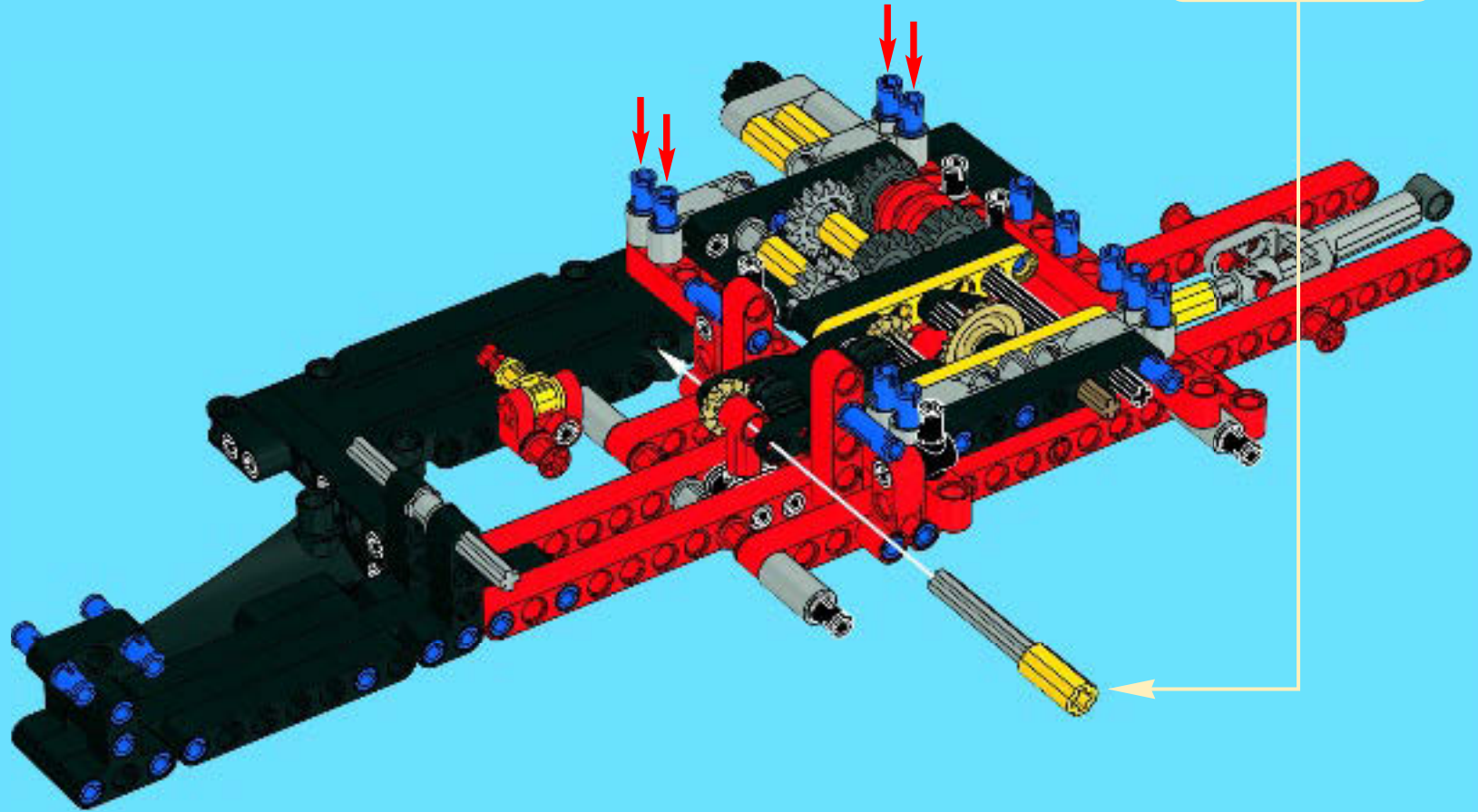

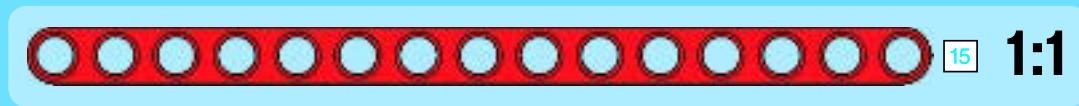

# 23

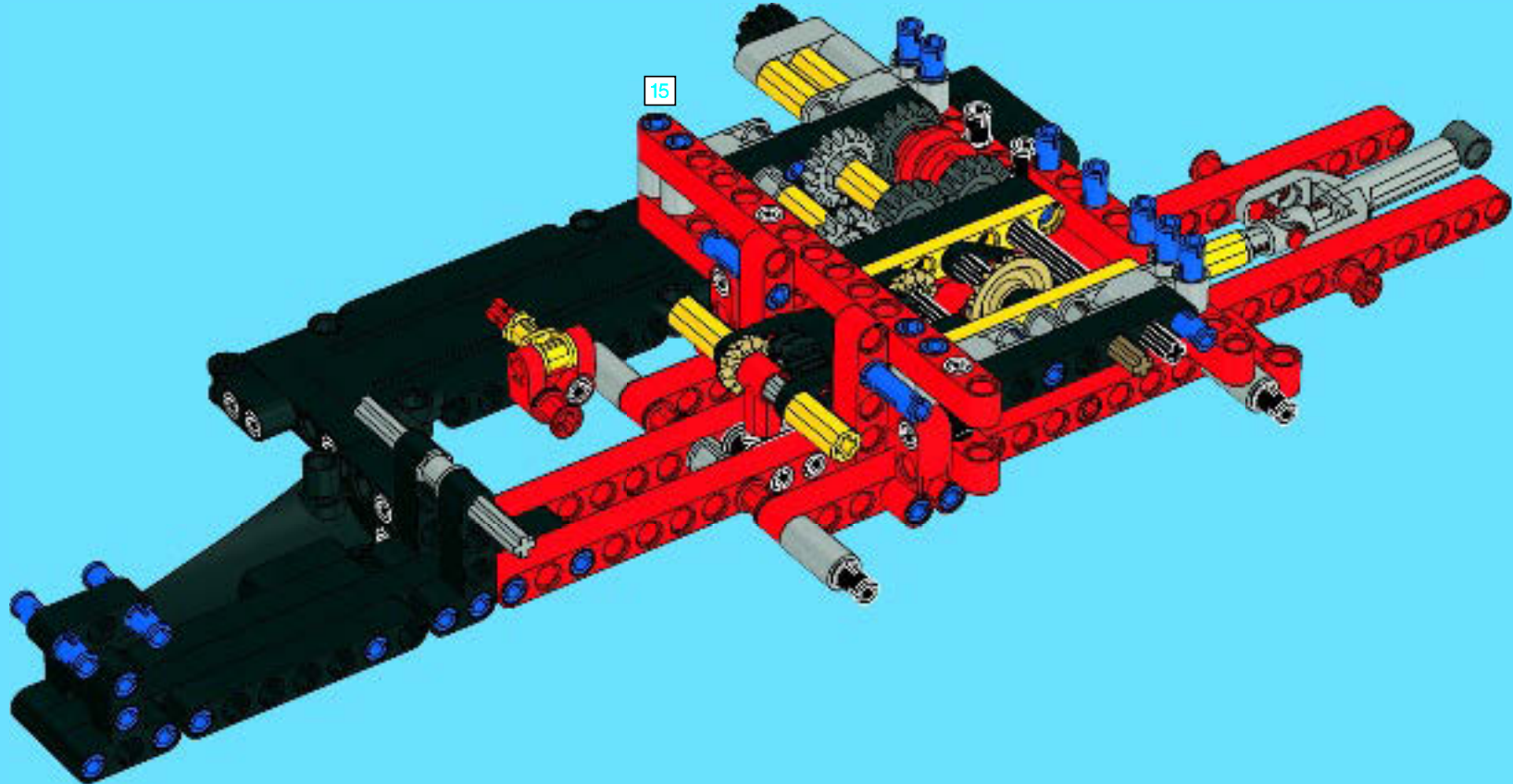



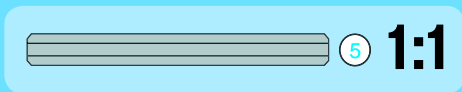
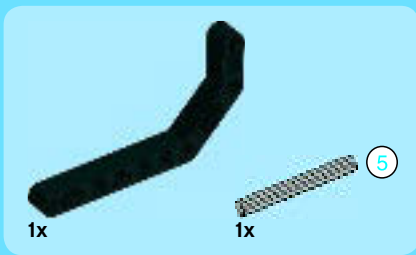

24

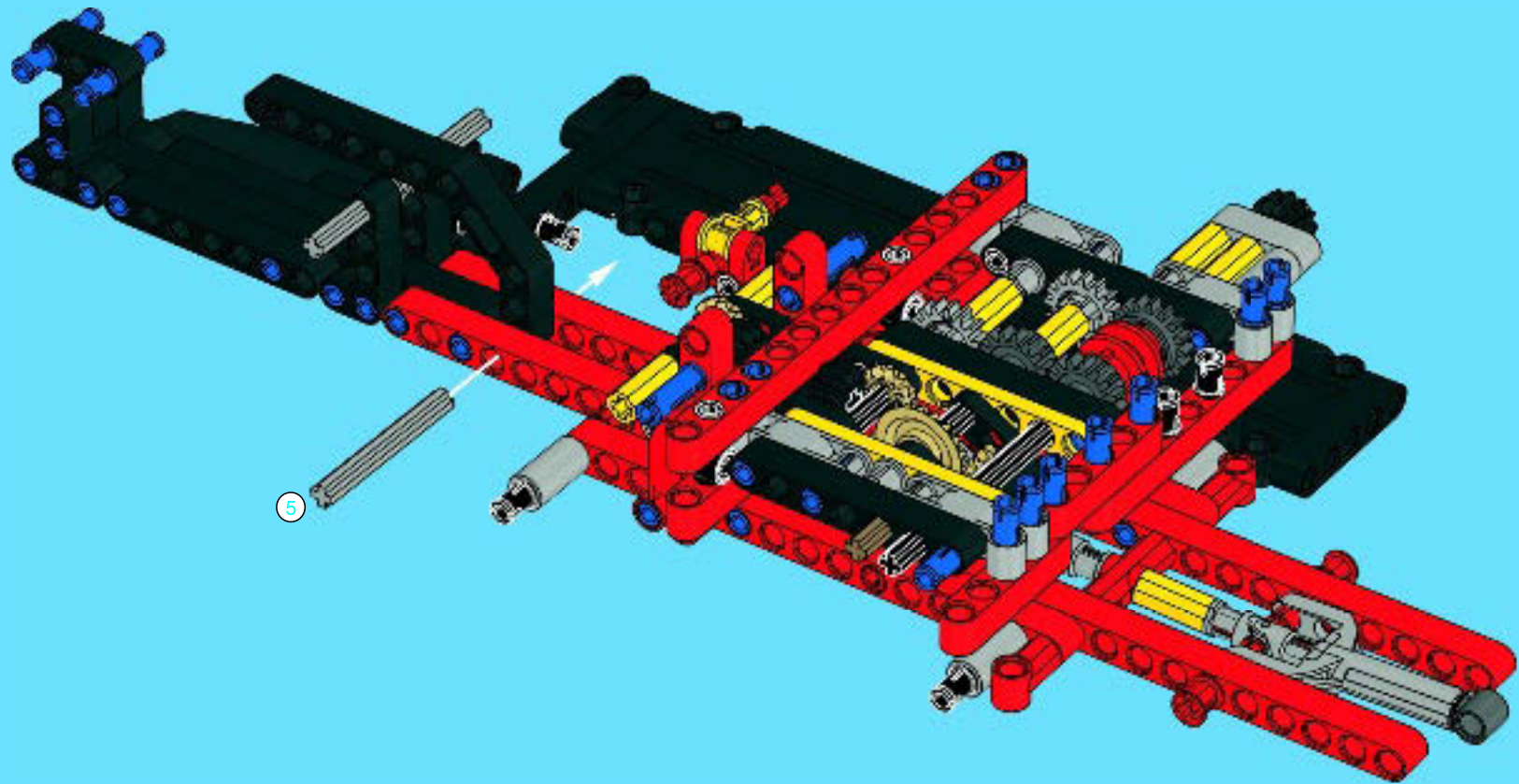

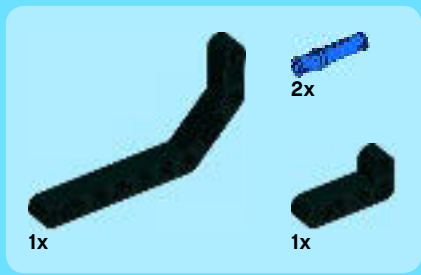

25

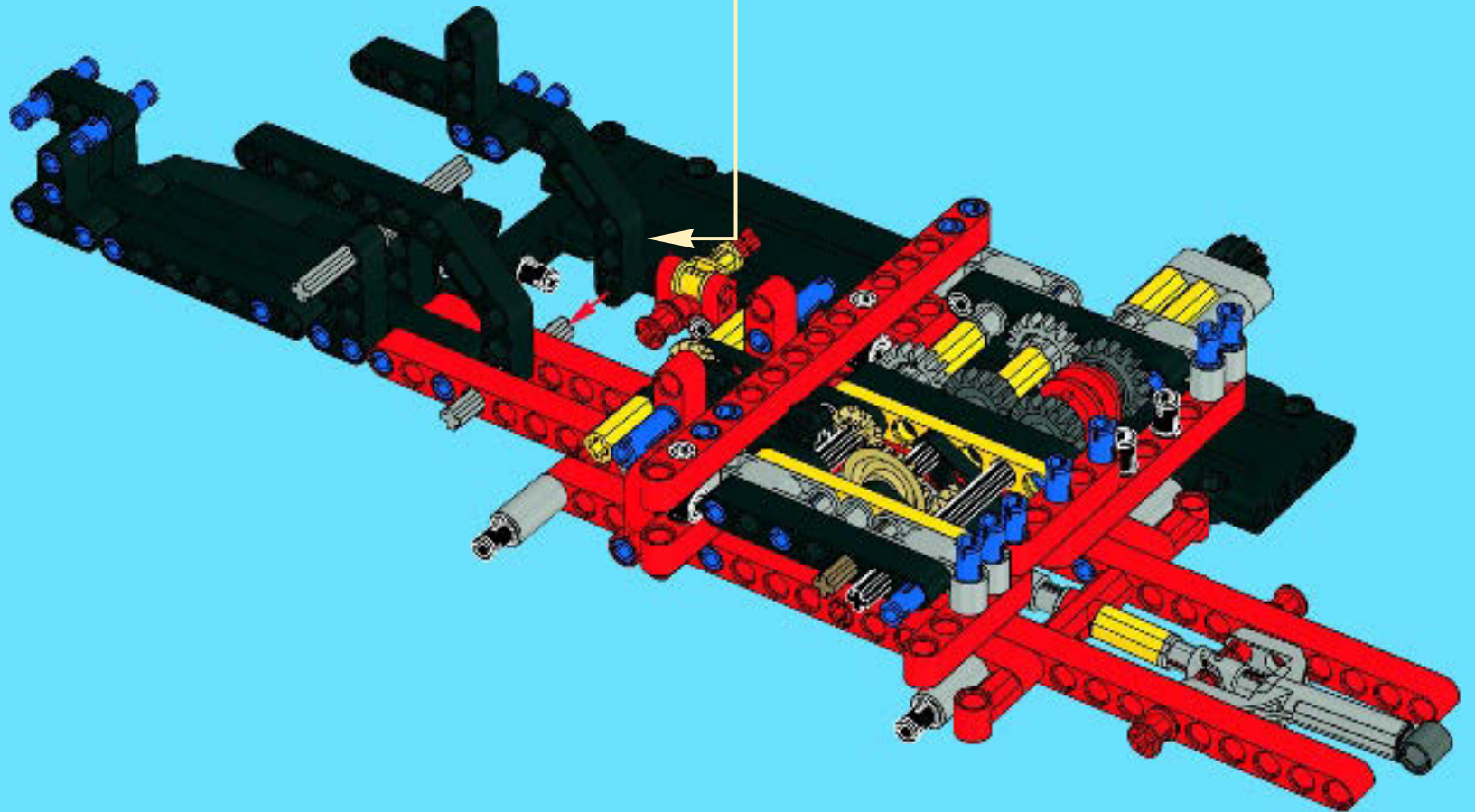
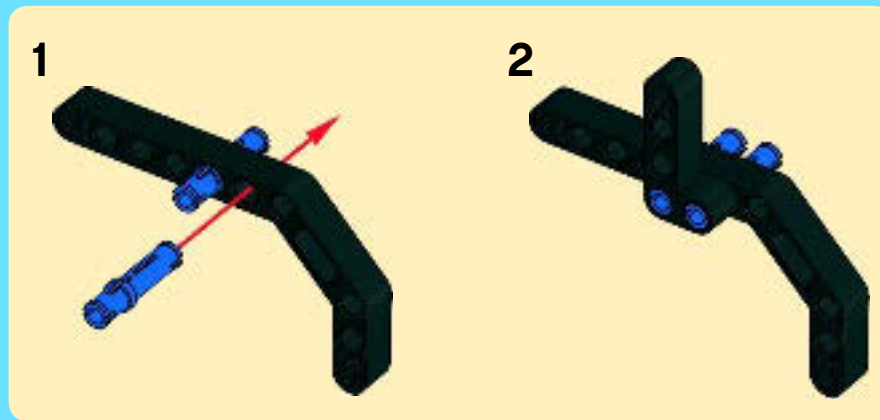

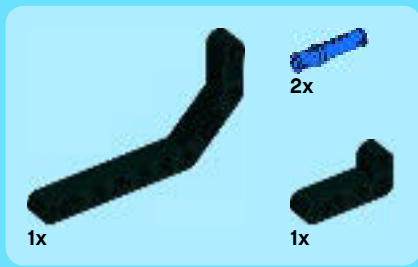

26

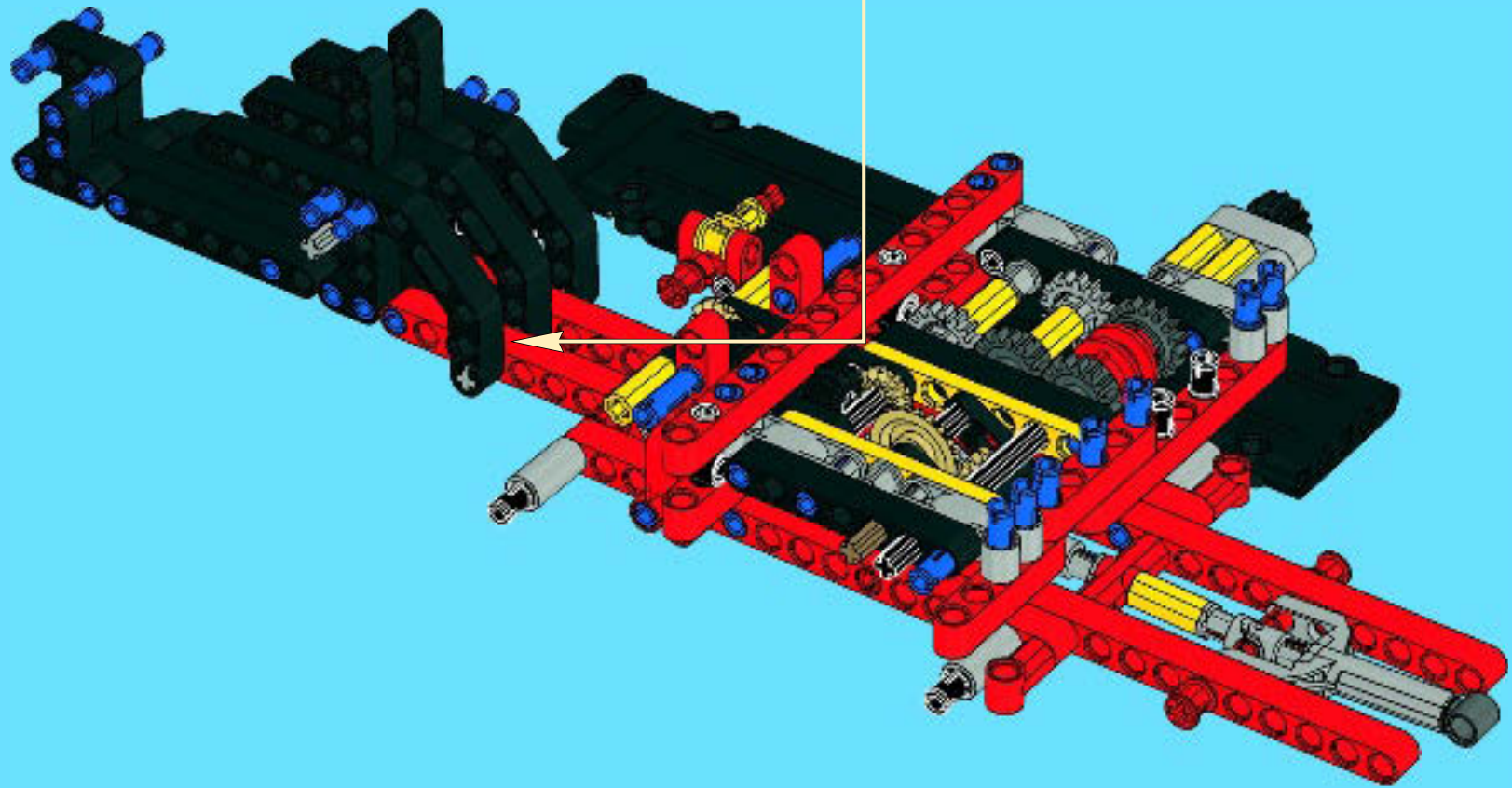
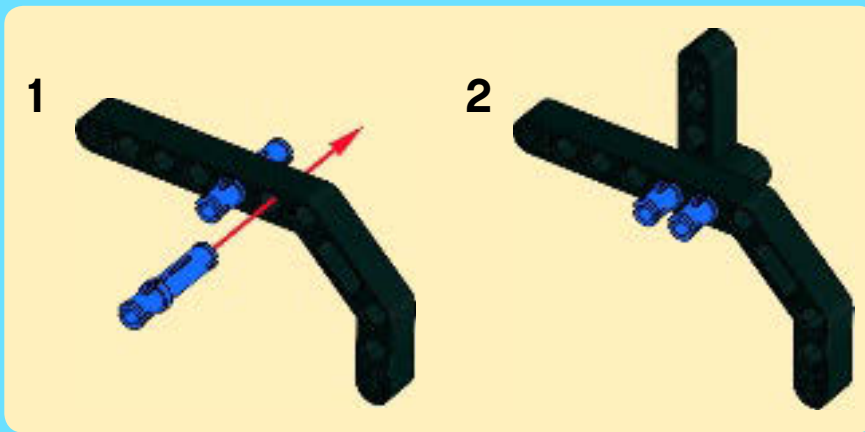

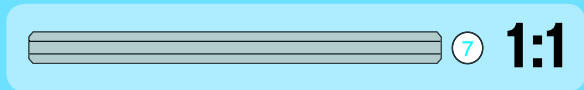
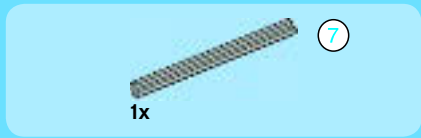

27

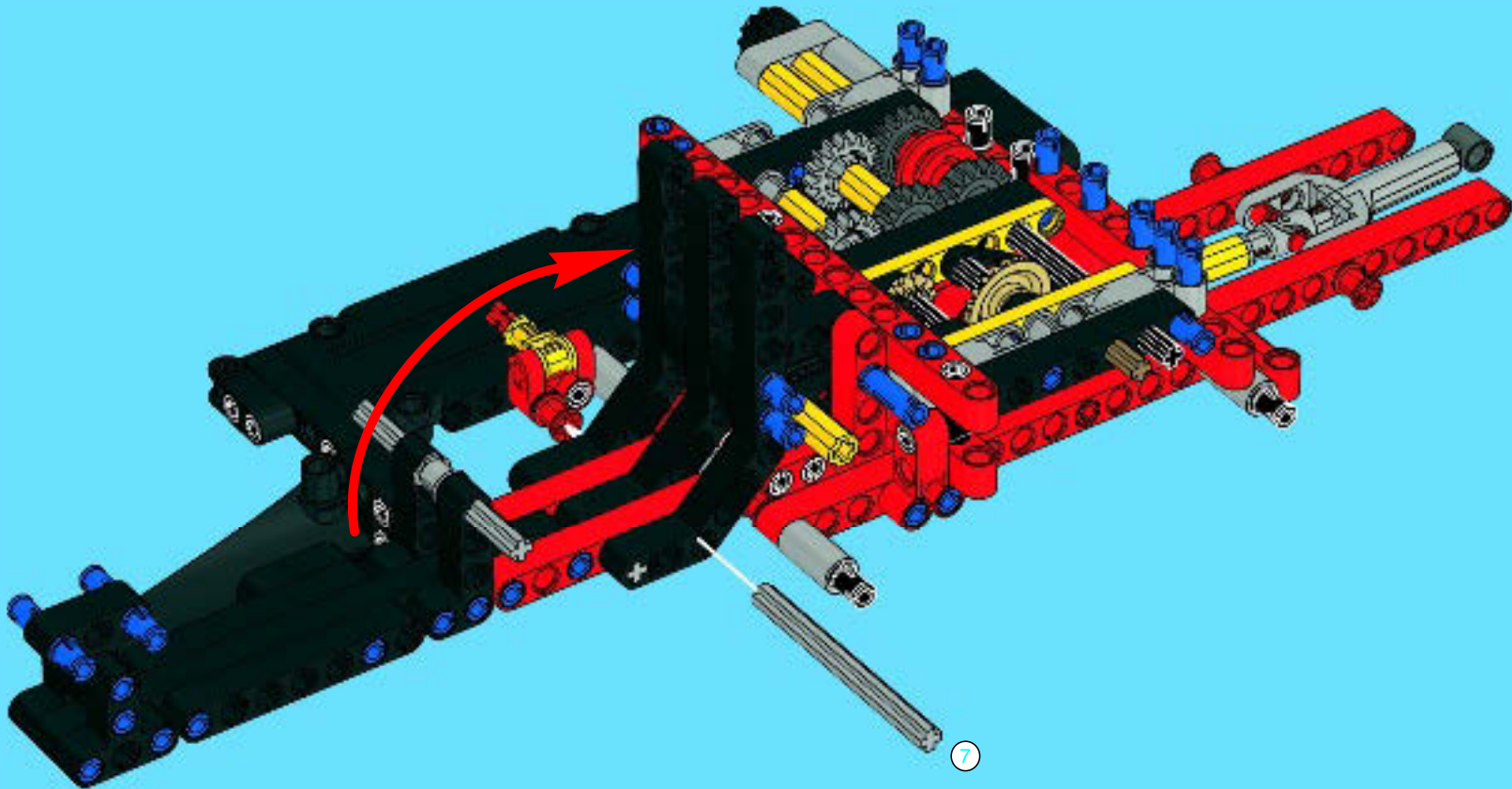

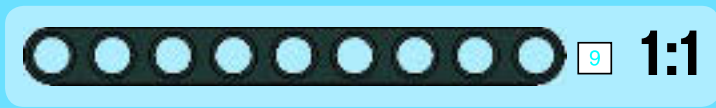
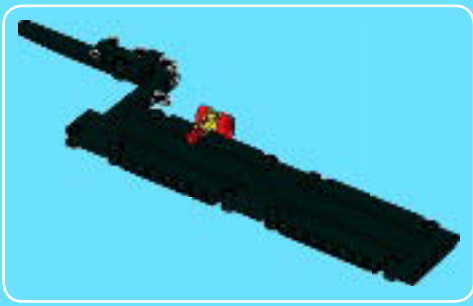

1



2



3

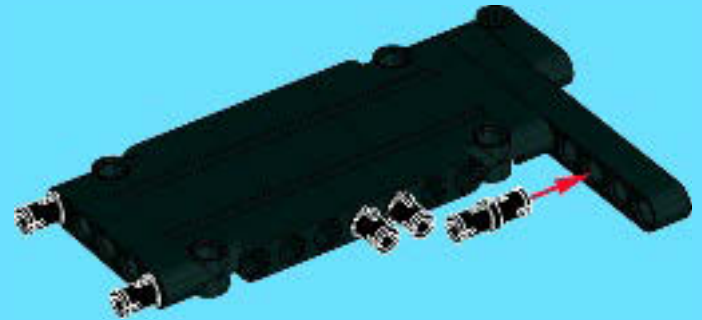

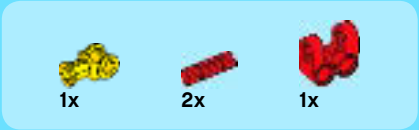

4

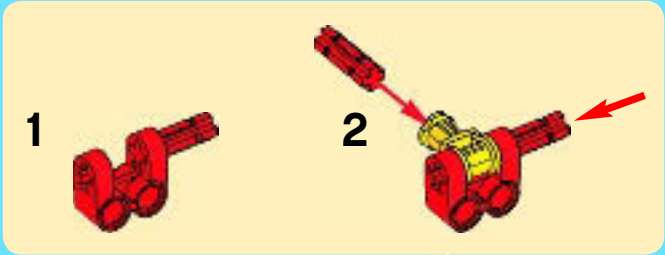
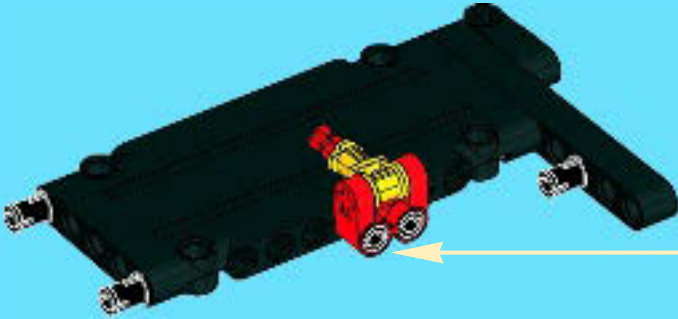

5

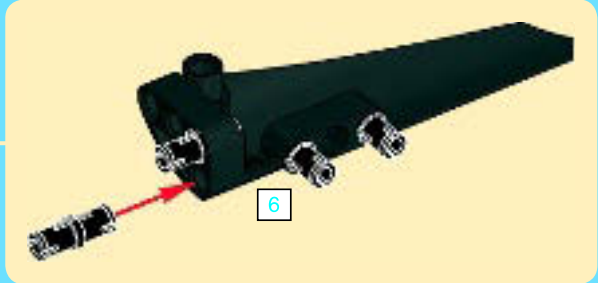
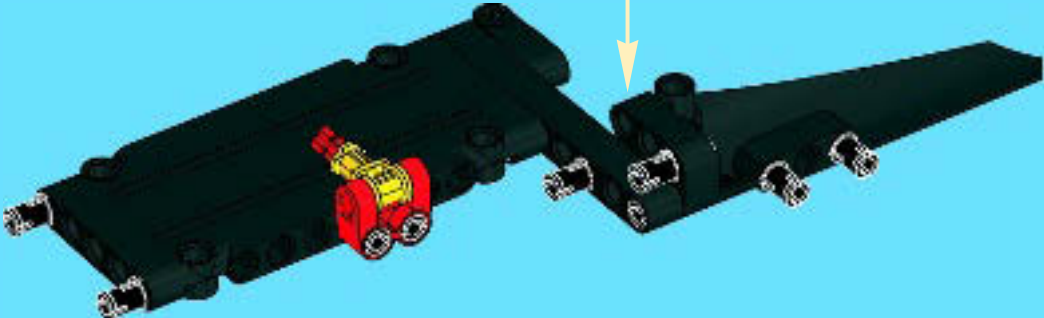



6

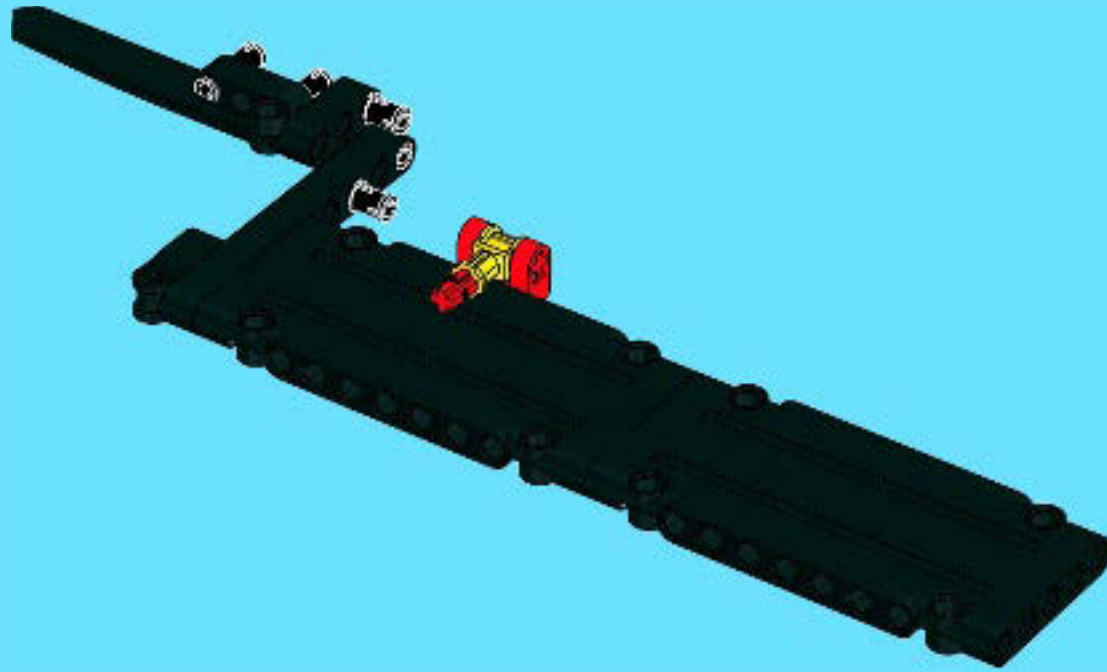

28

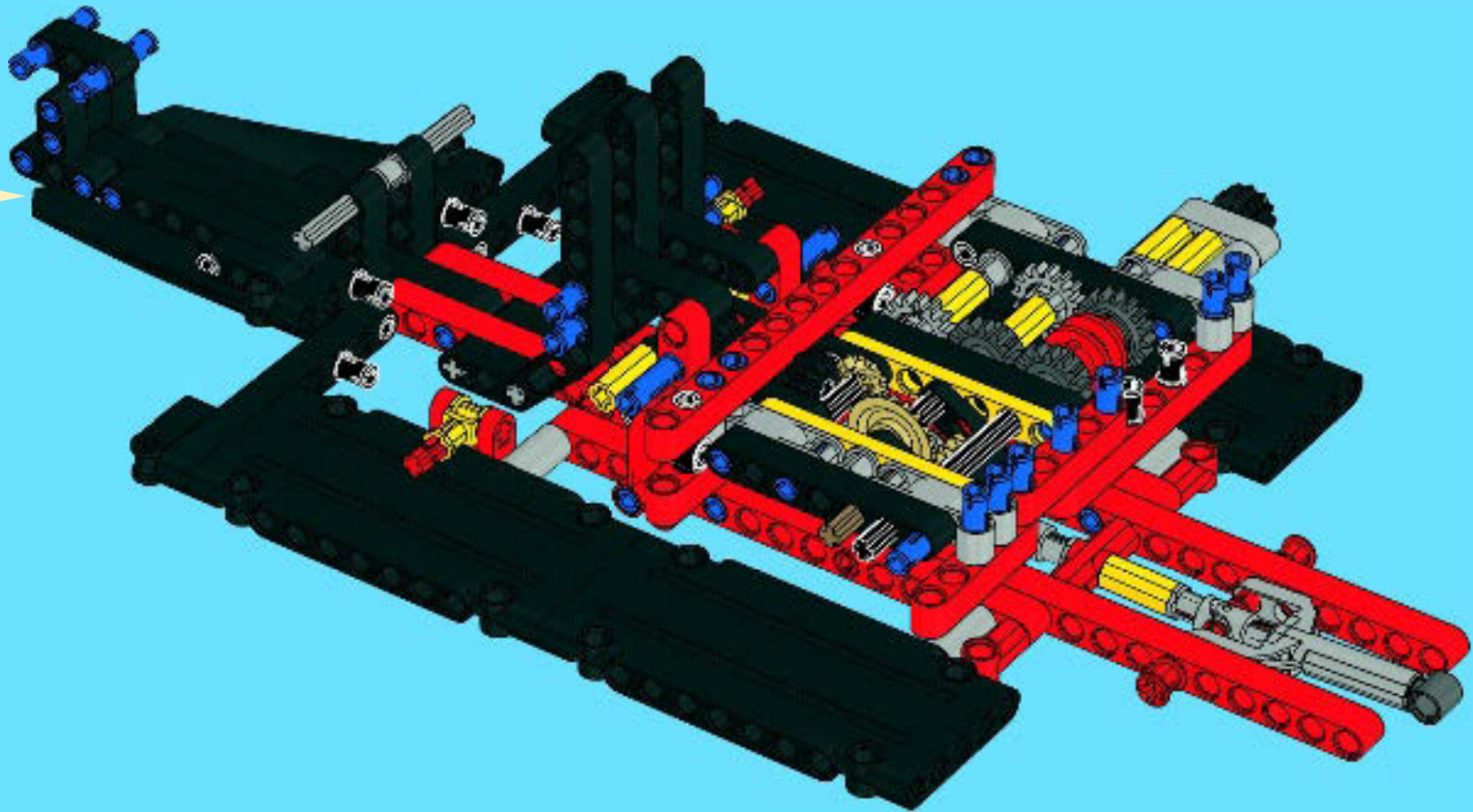





29

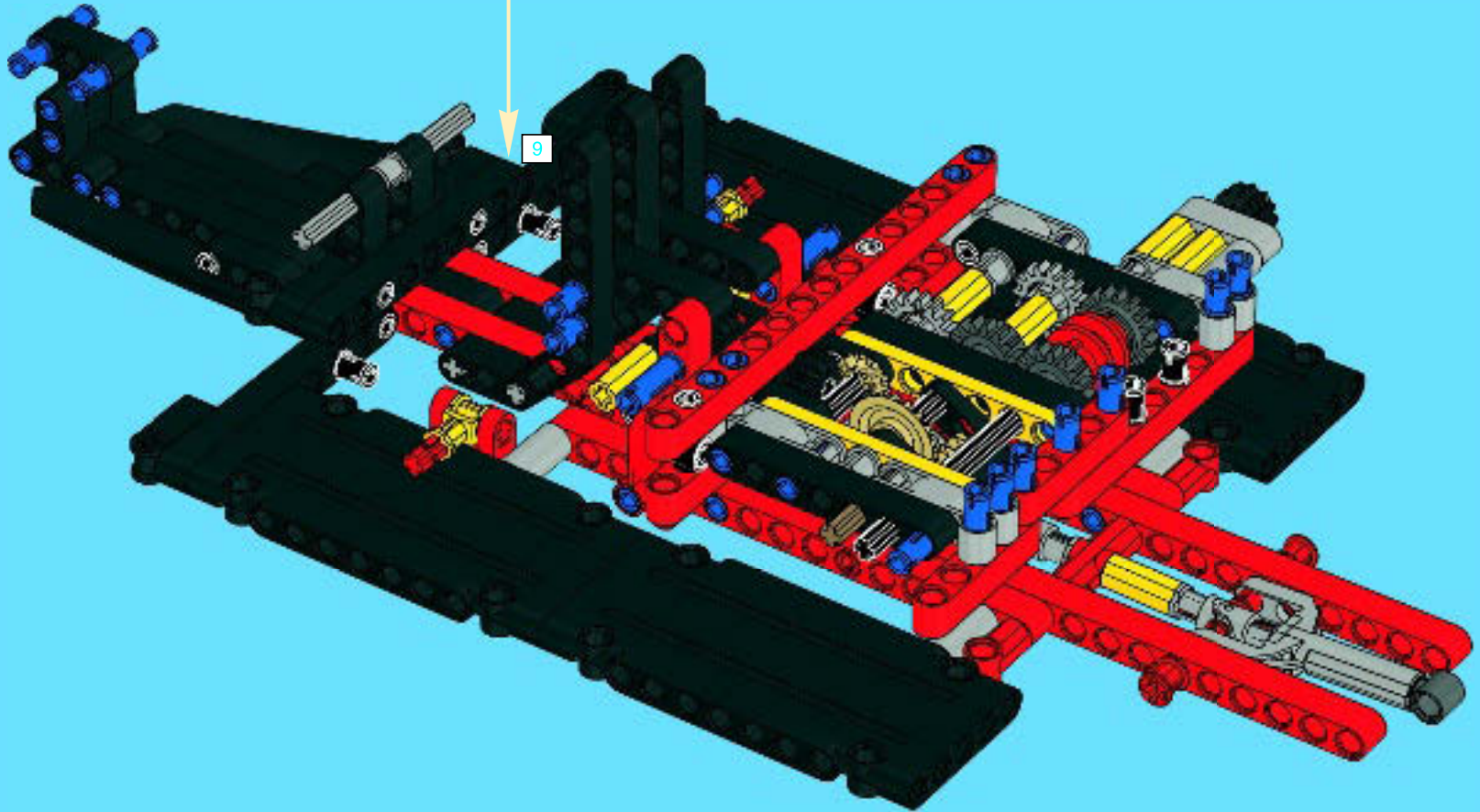



2x



2x

# 30

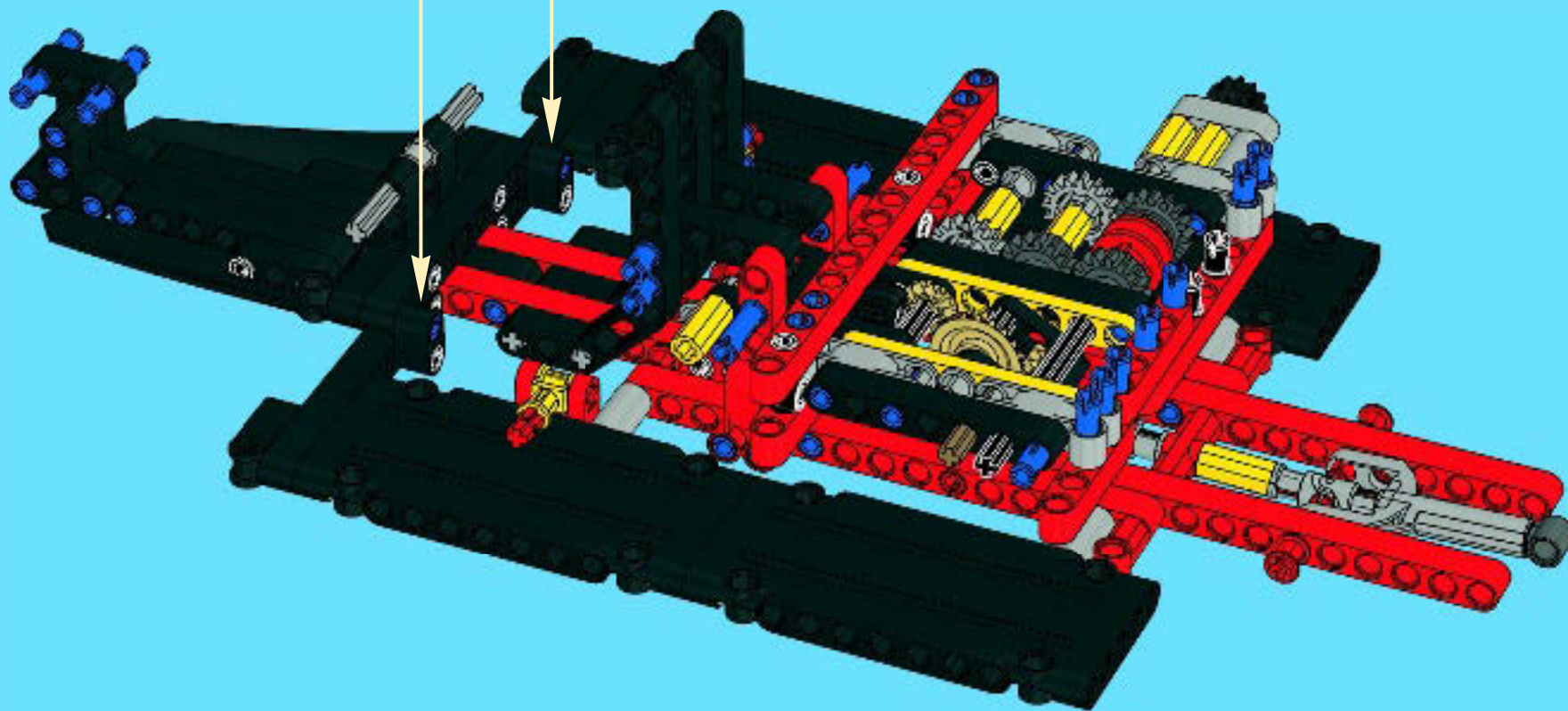
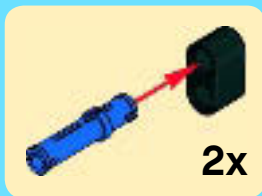

5x

1x

# 31

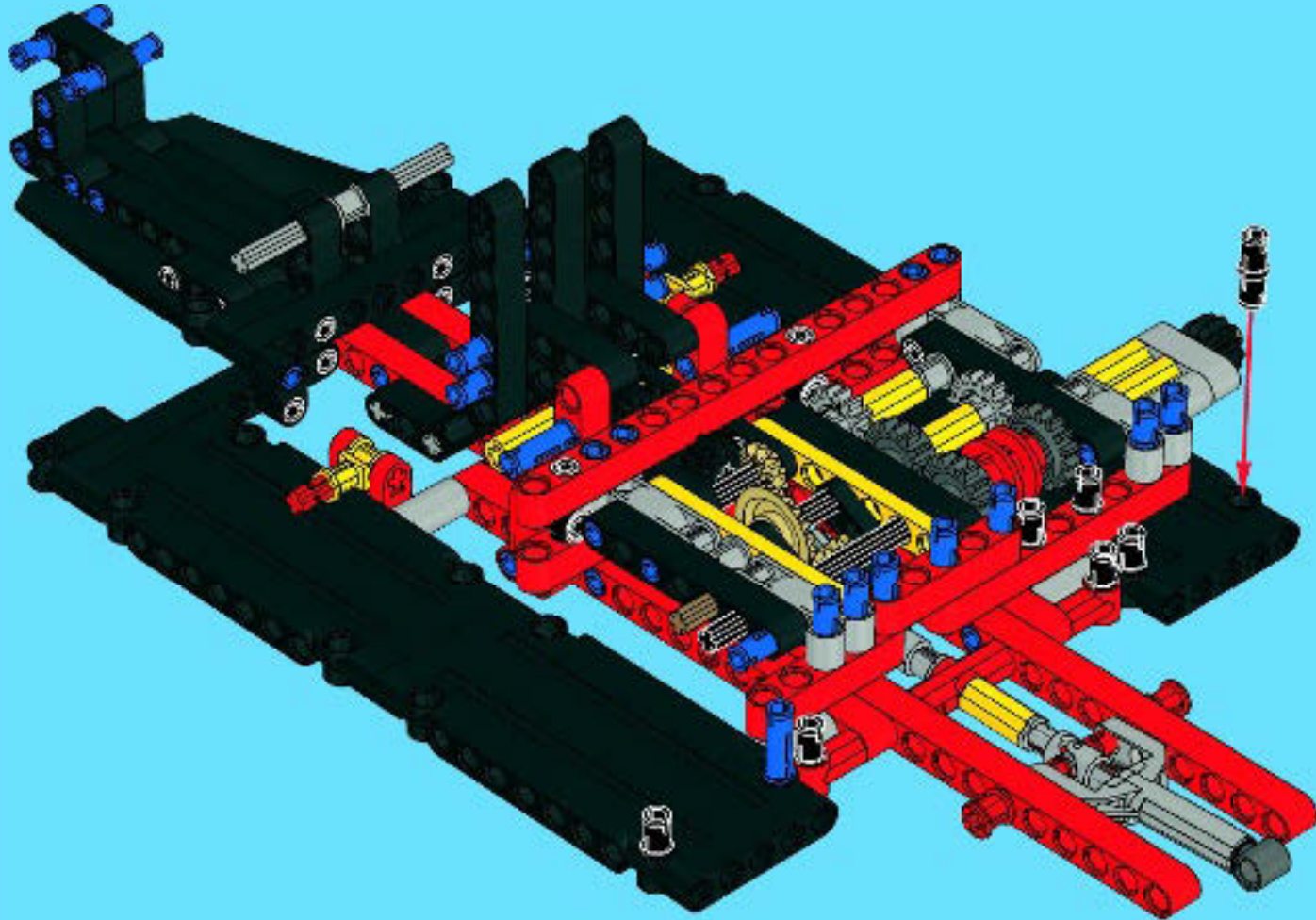

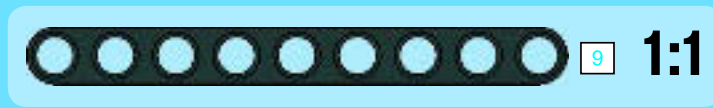

32

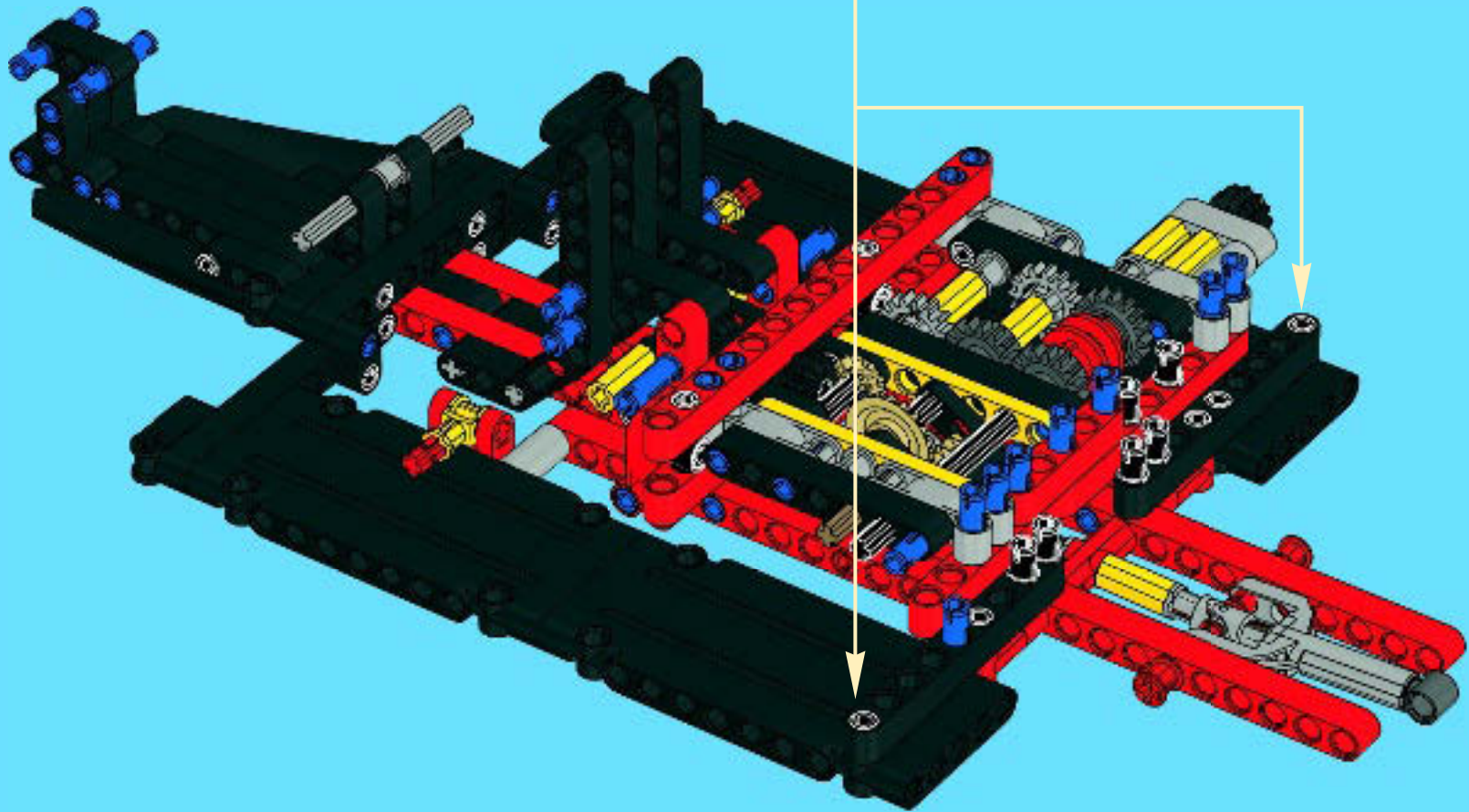

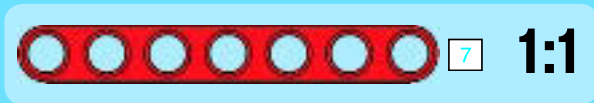

33

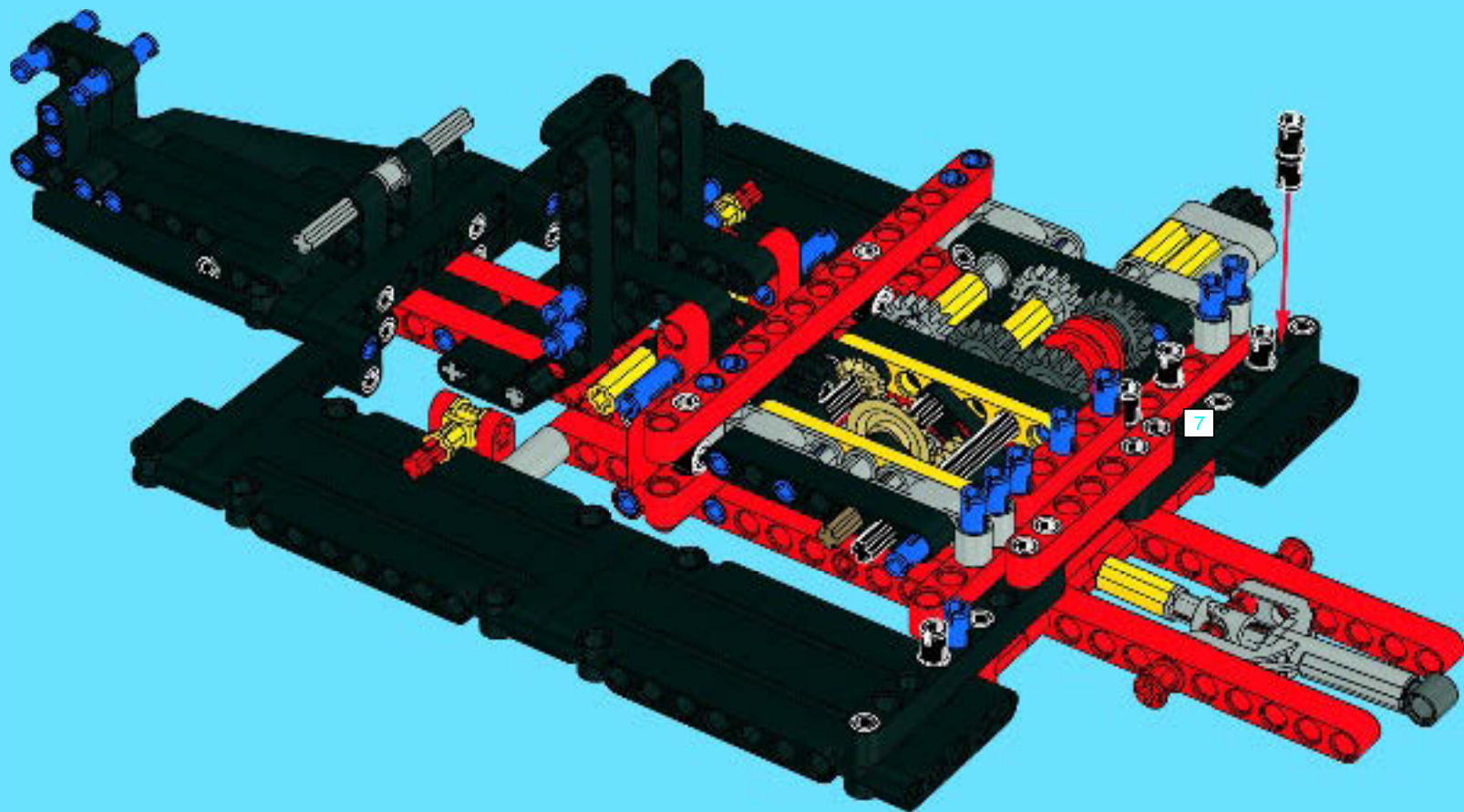



# 34

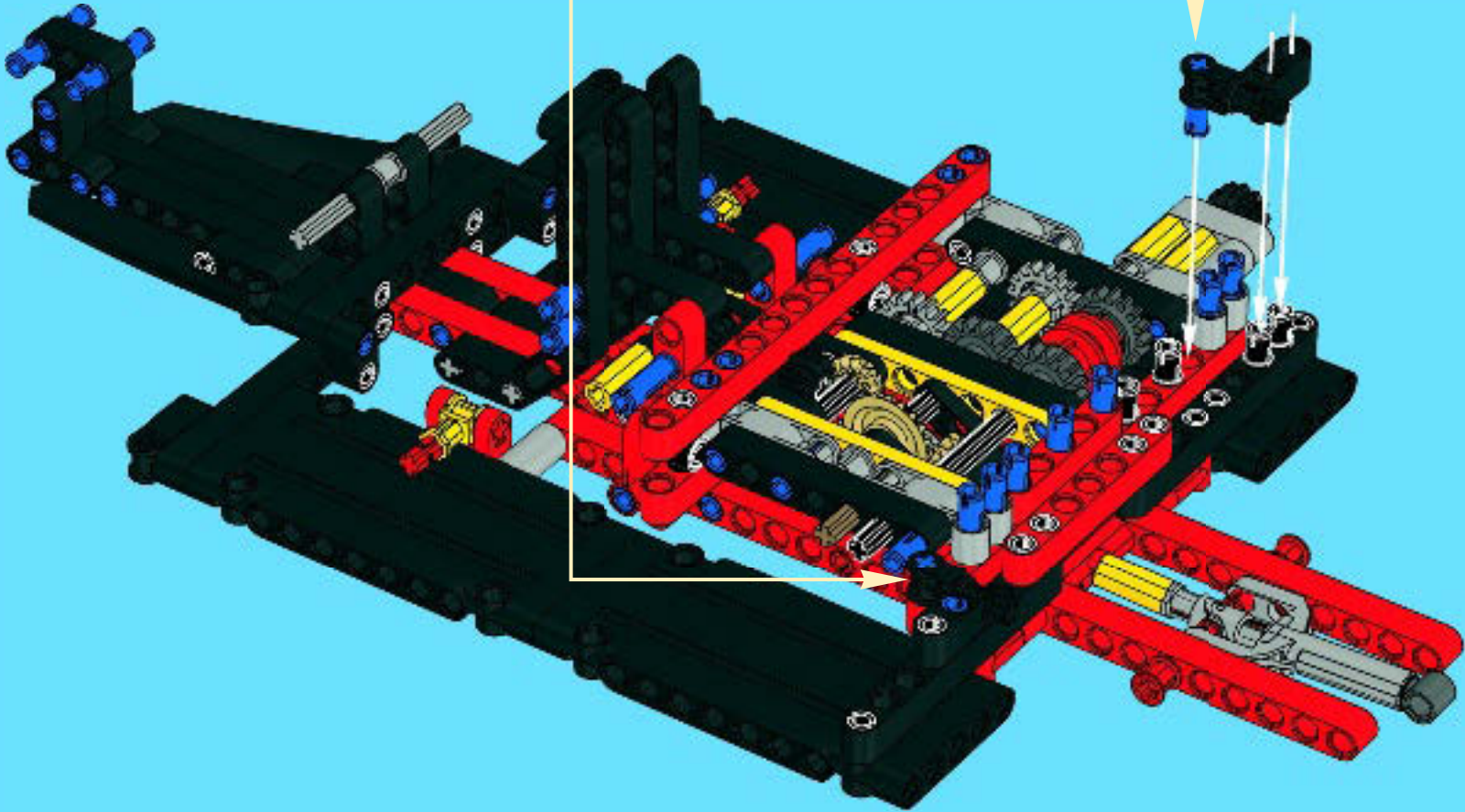

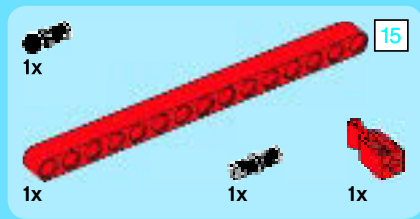

35

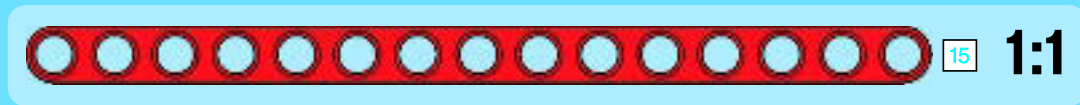
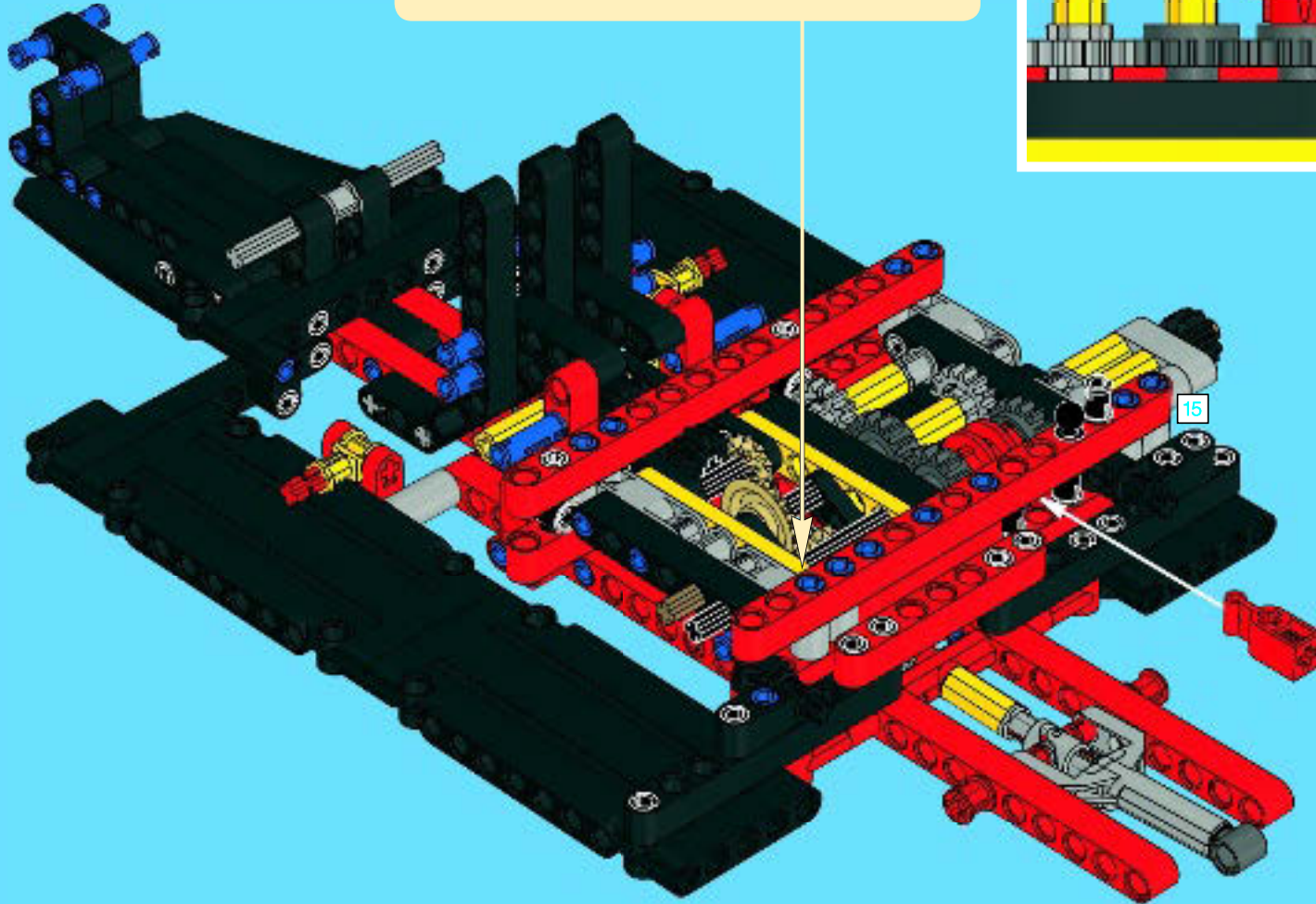
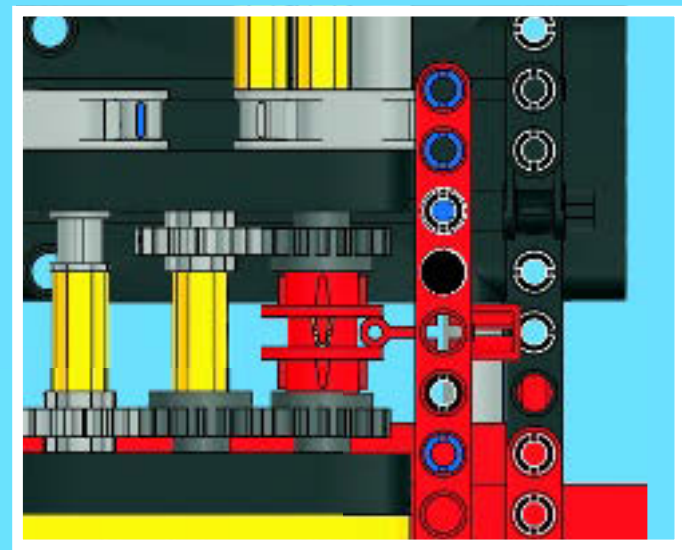
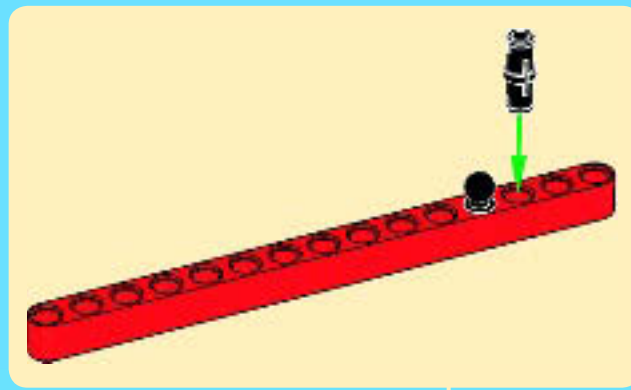

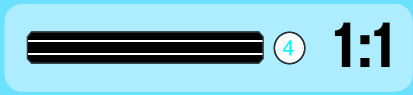
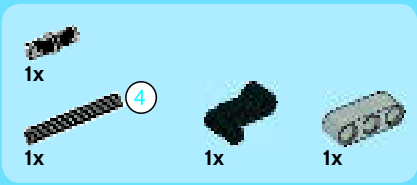

36

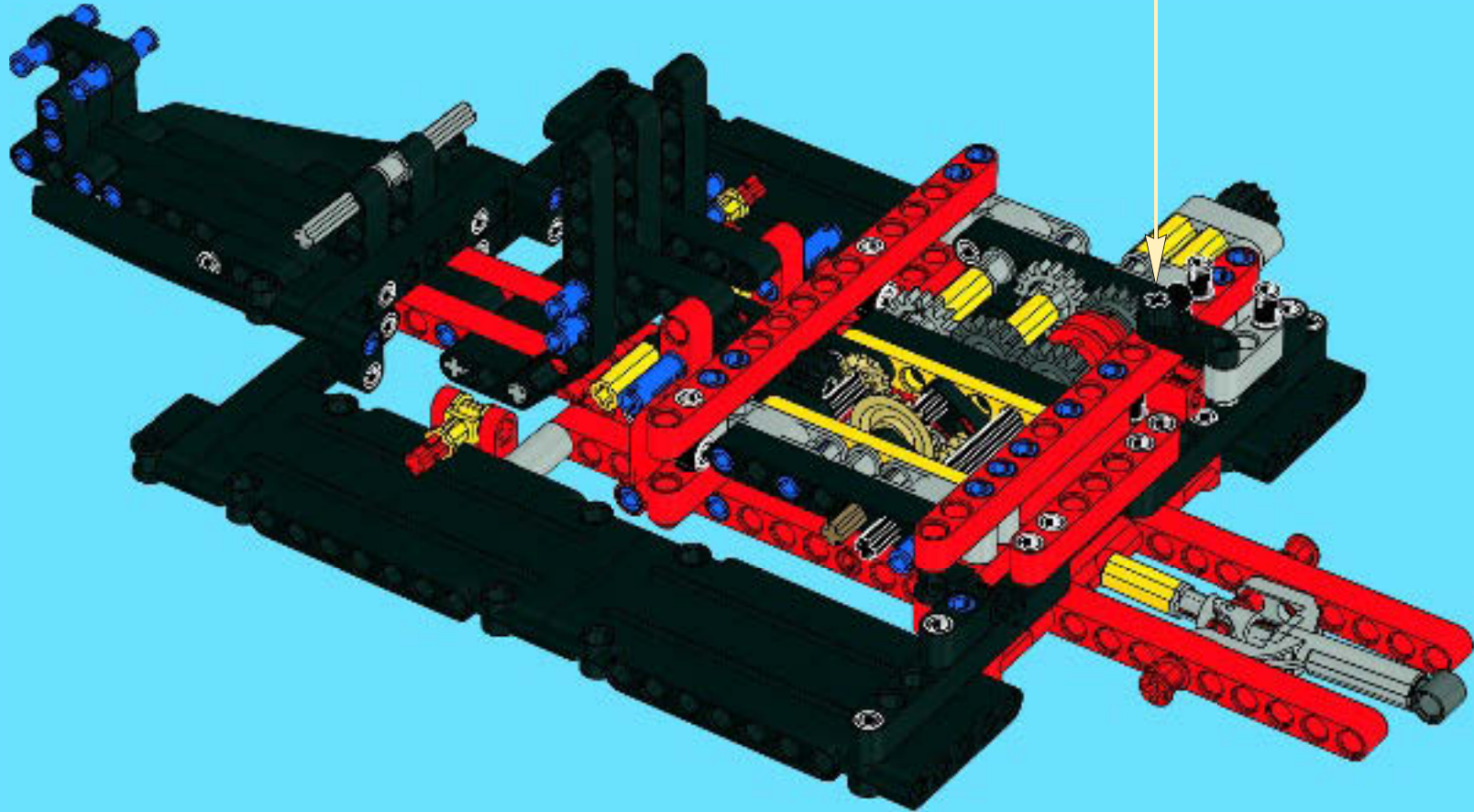



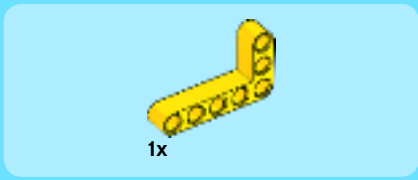

37

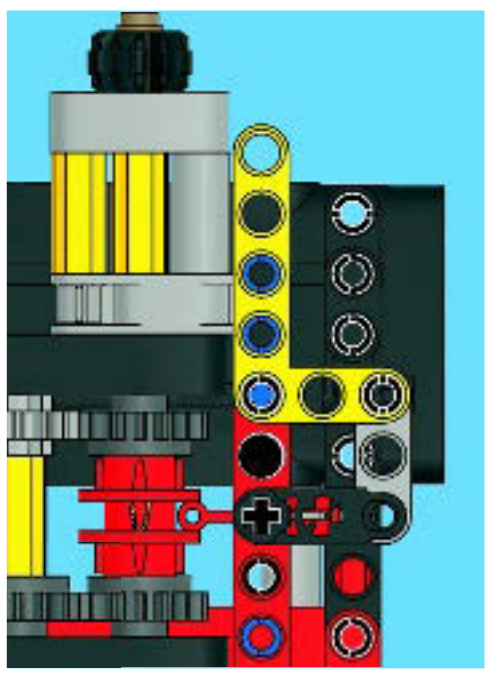
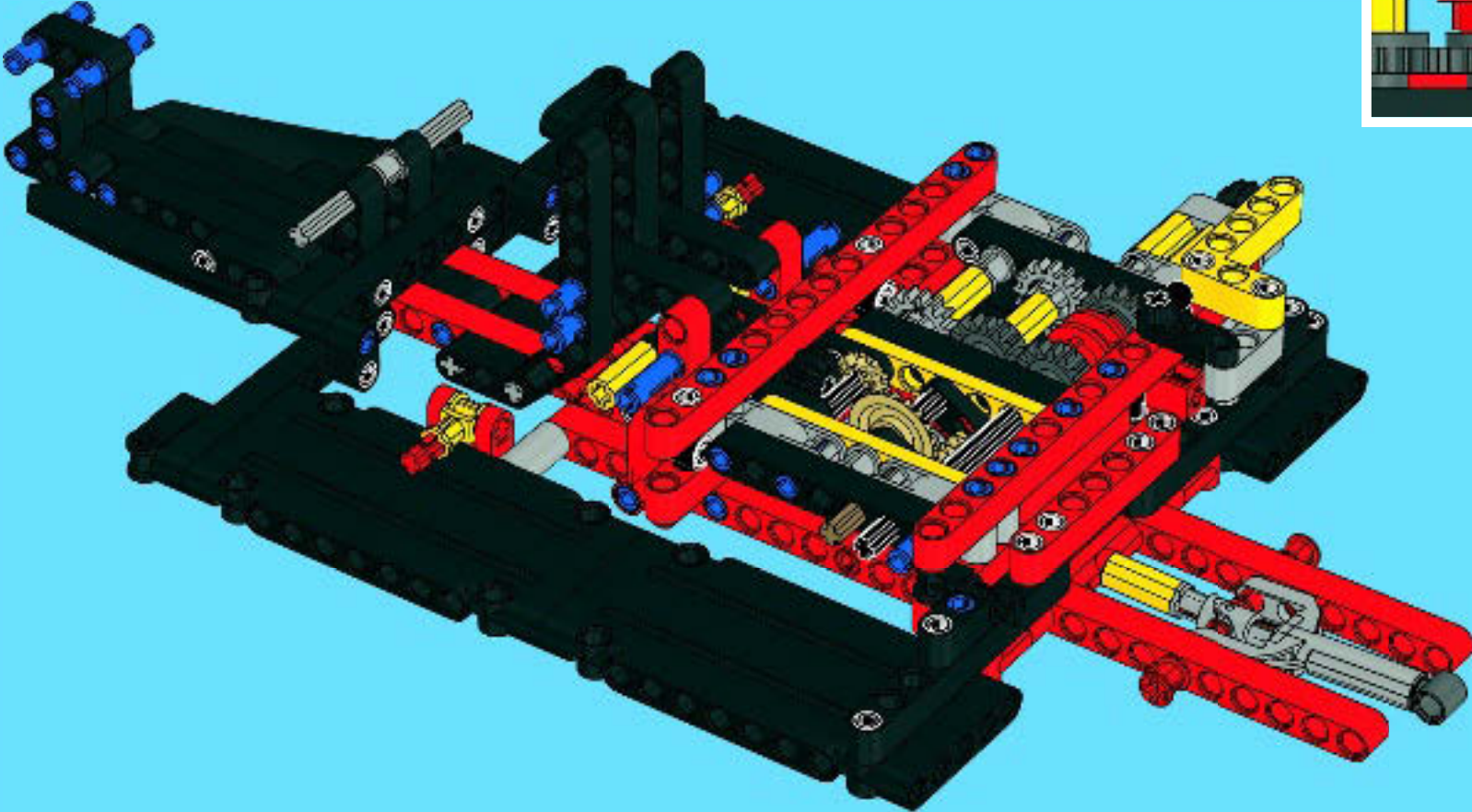

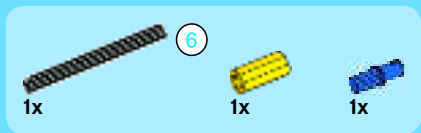

1

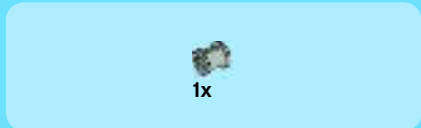
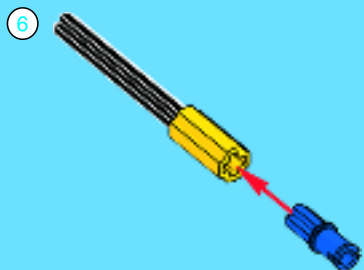

2

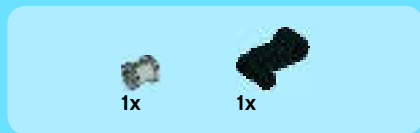



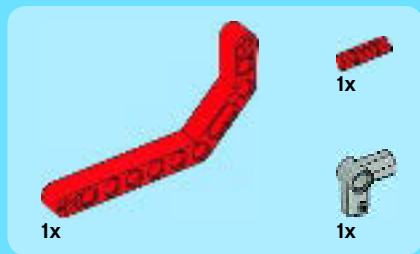
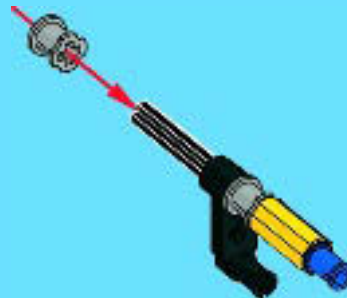

3

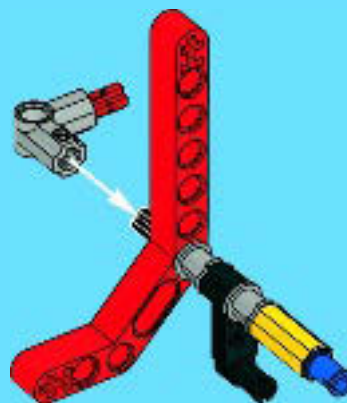
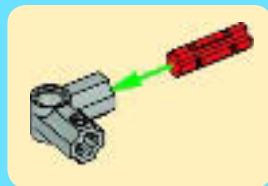

4



- 1x 
- 1x 
- 1x 
- 1x 

5

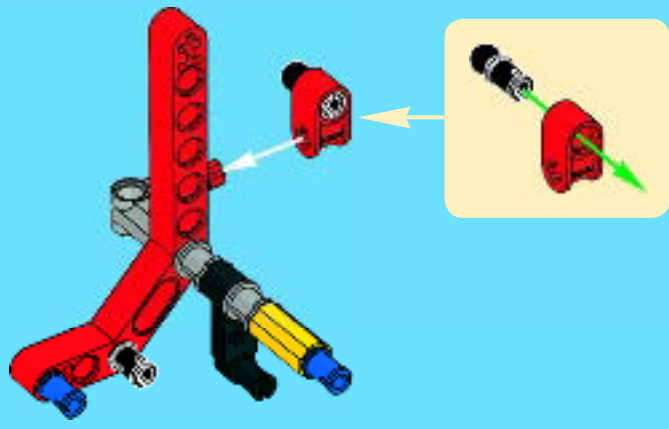

38

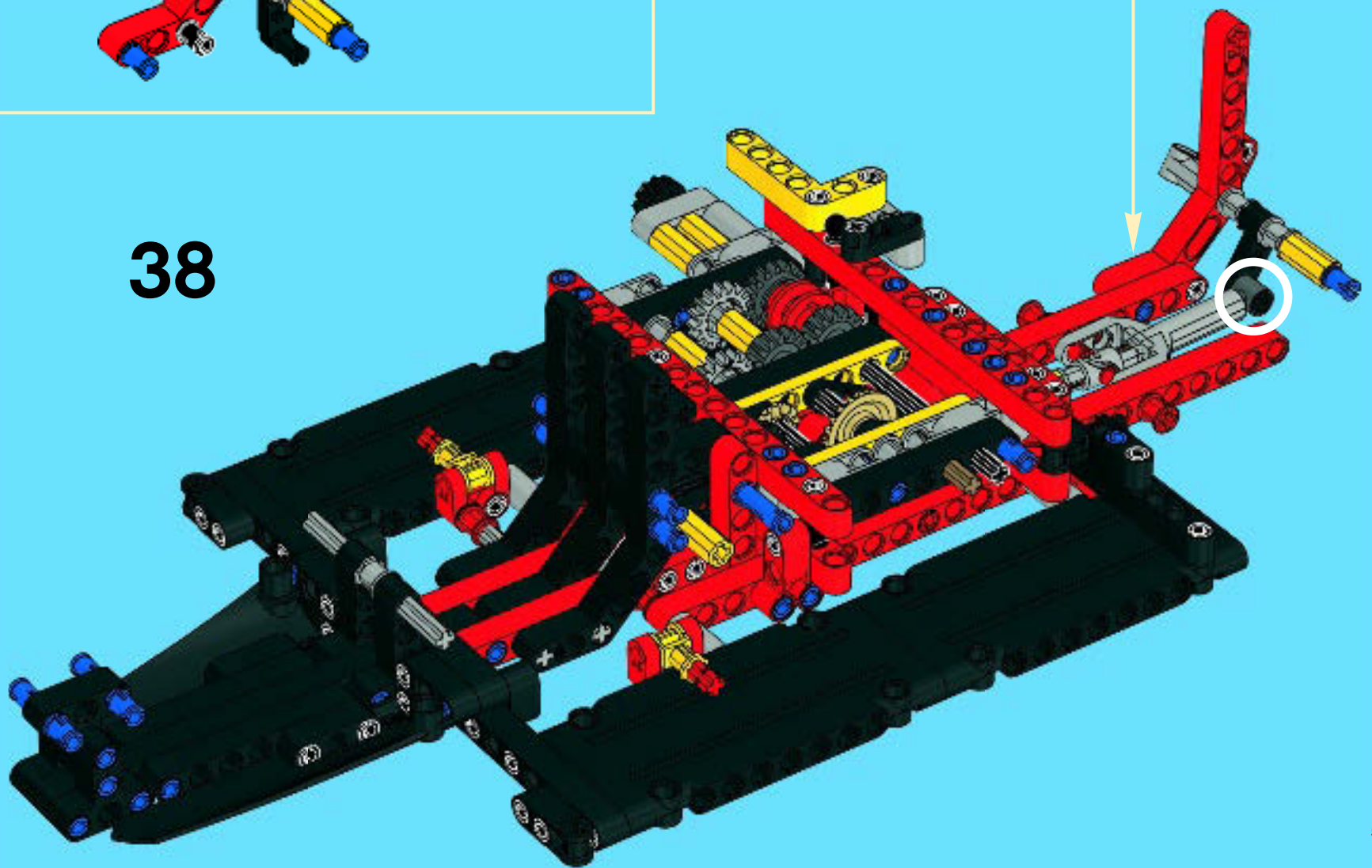

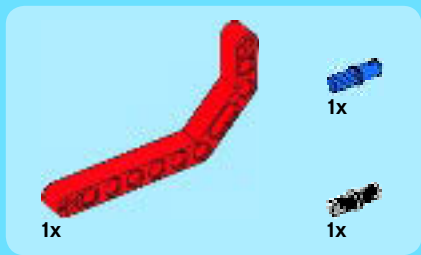

39

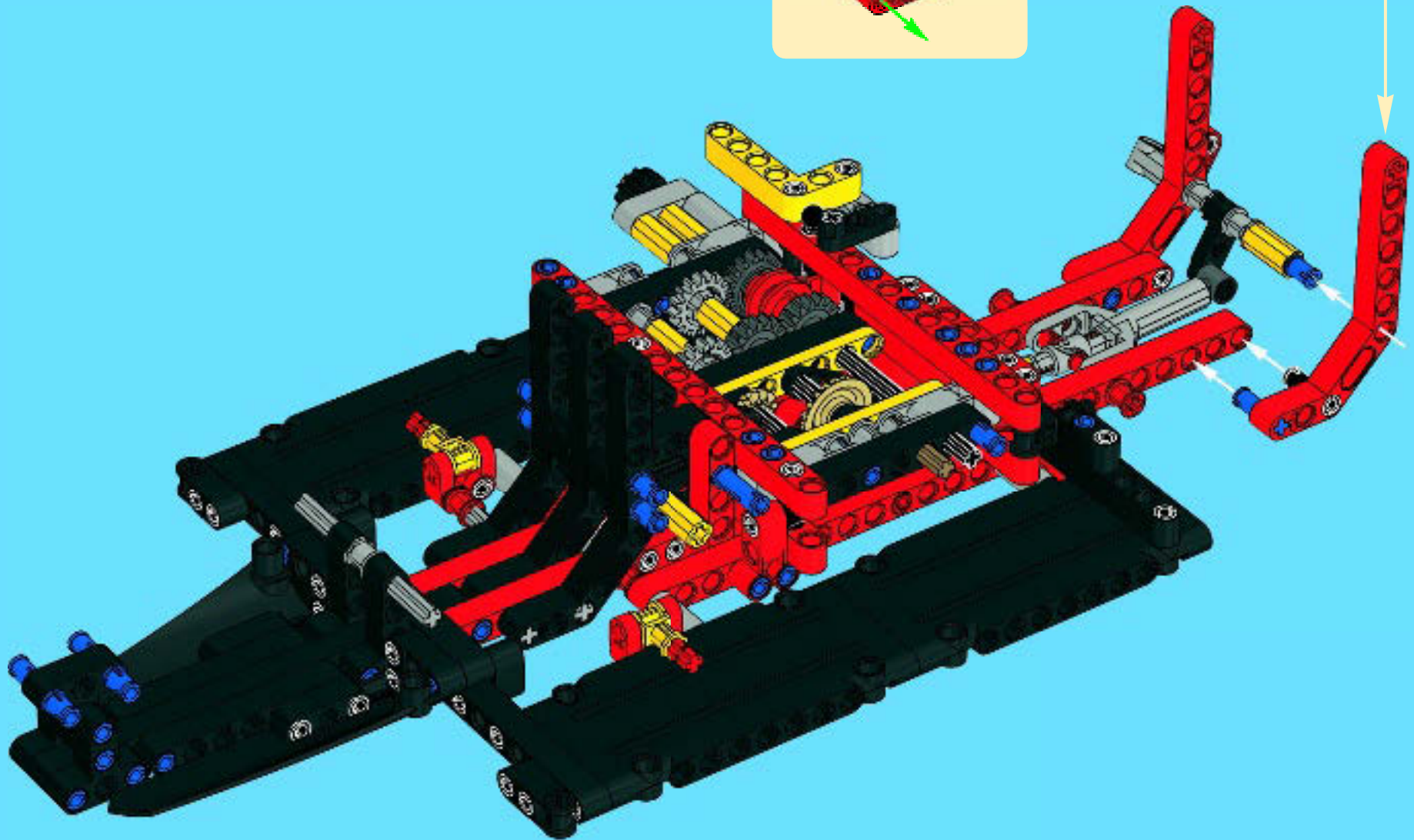
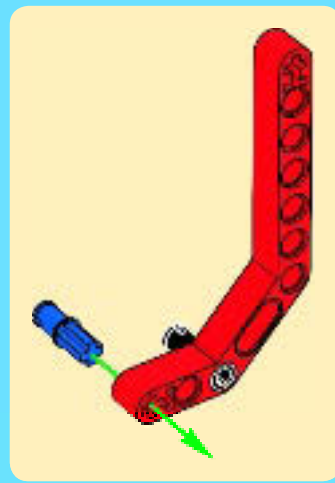

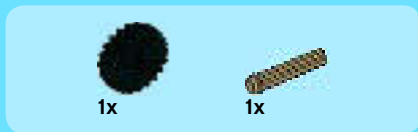
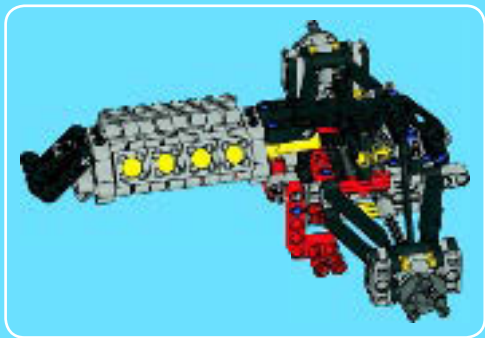

1

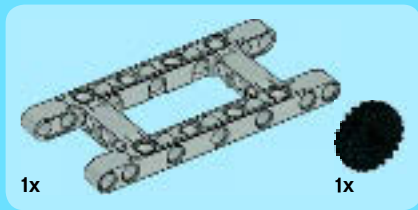
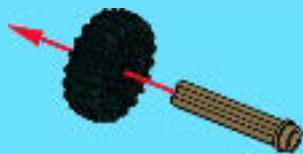

2

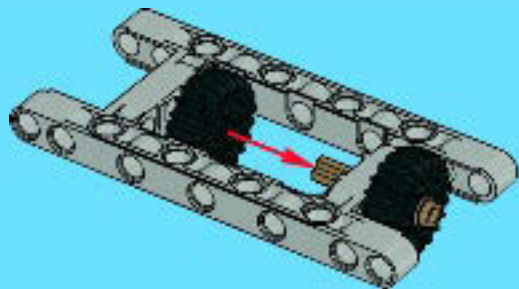

3

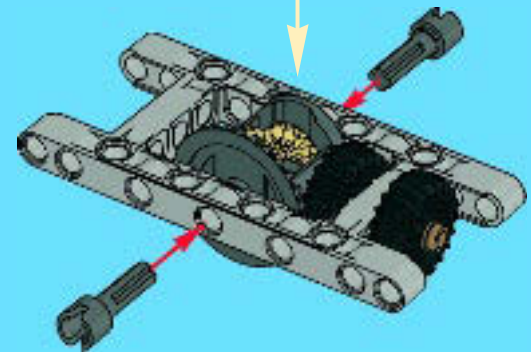
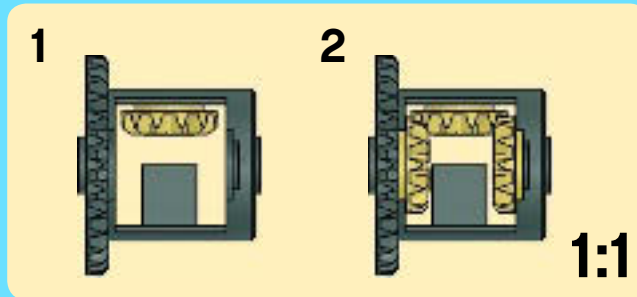

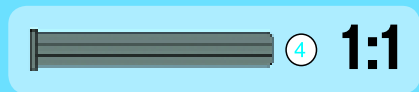
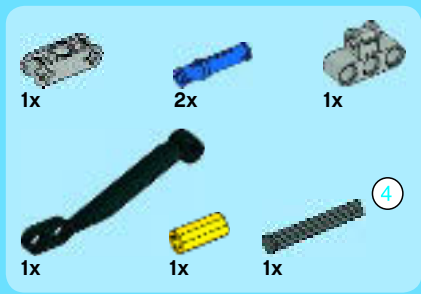

4

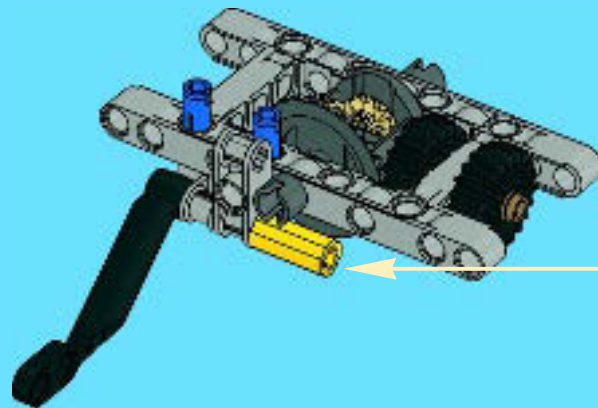
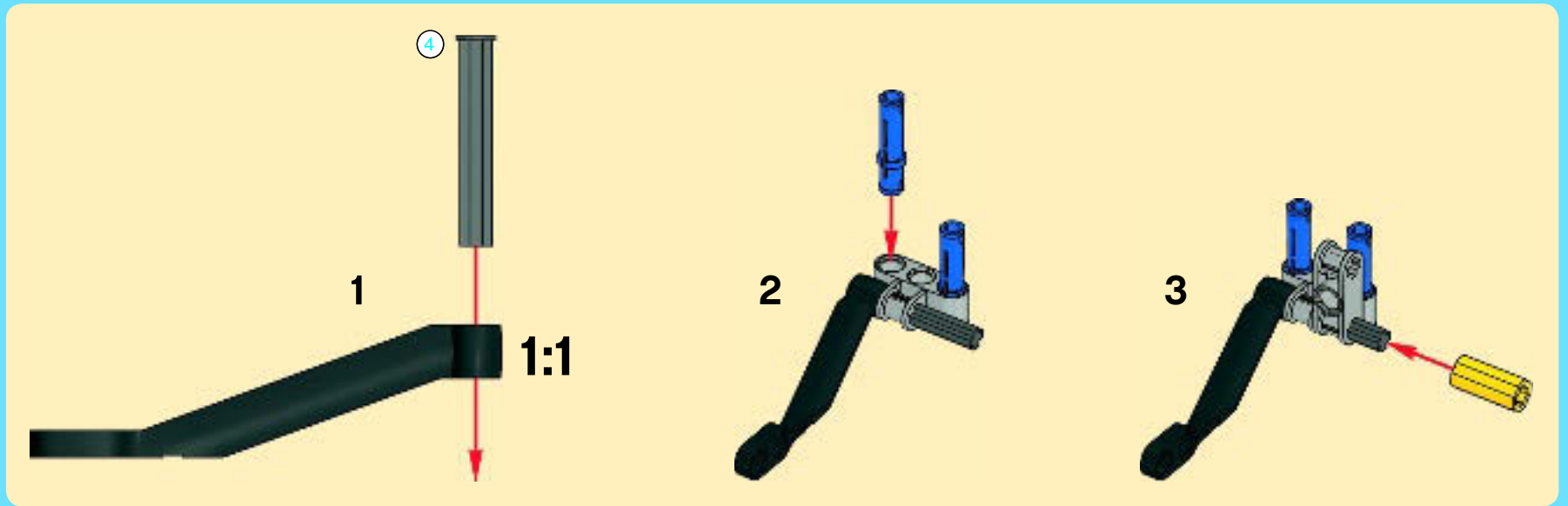

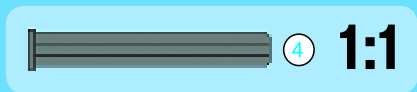
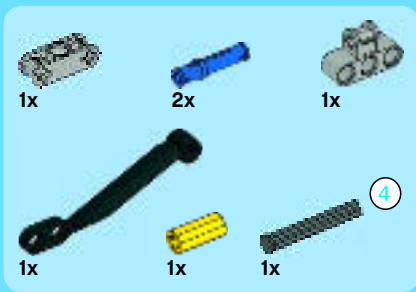

5

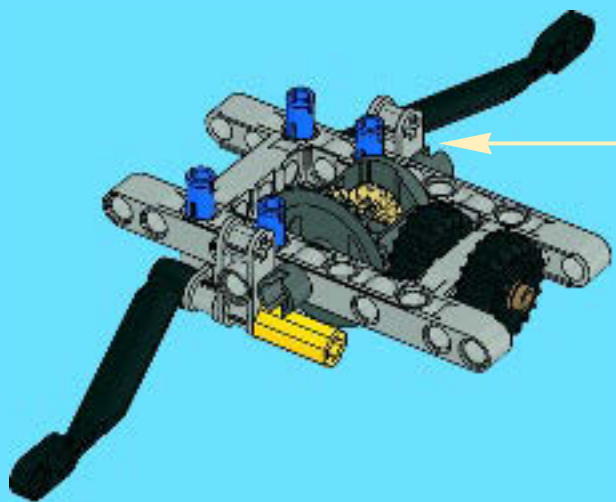
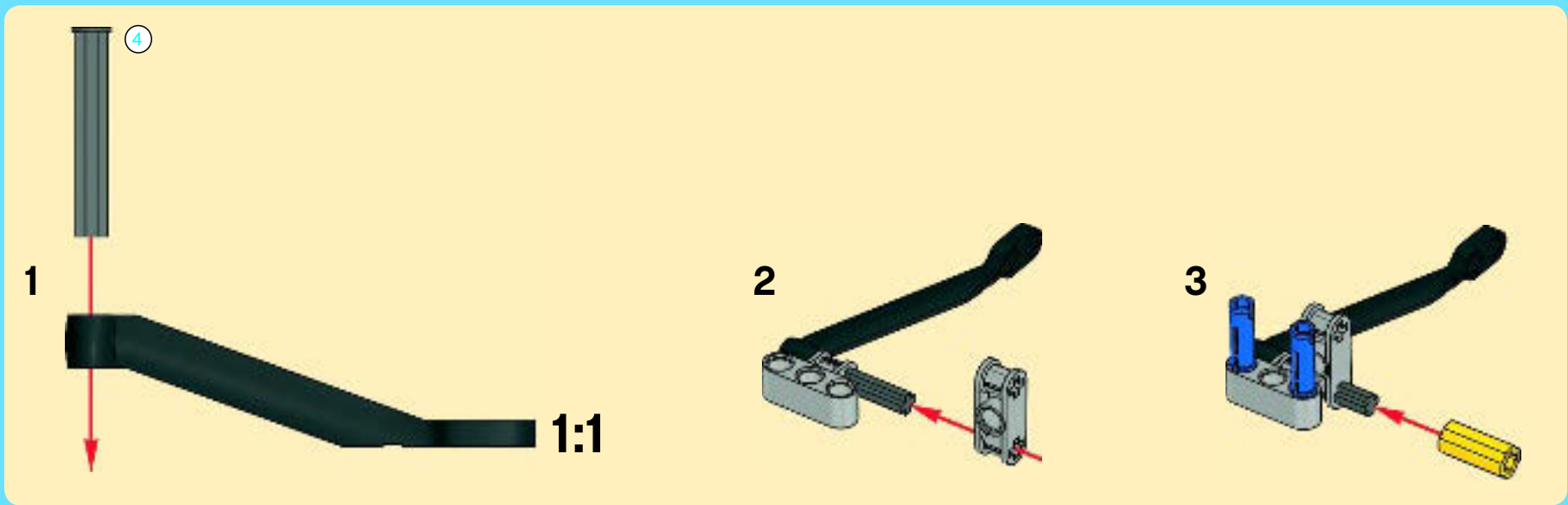



2x

6

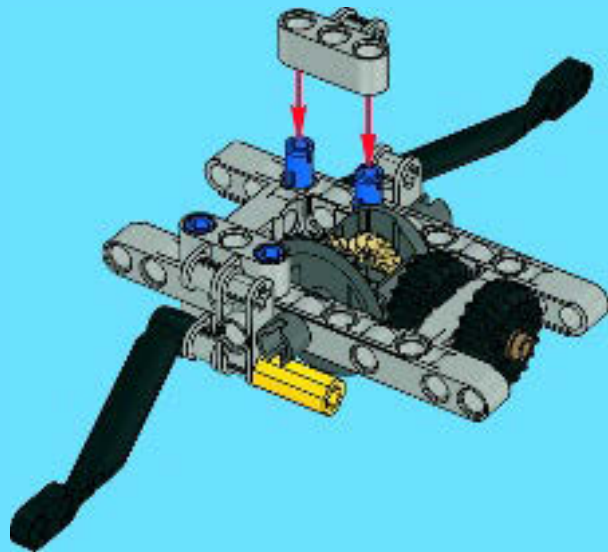

2x



2x

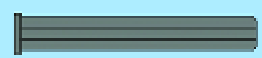

④ 1:1

7

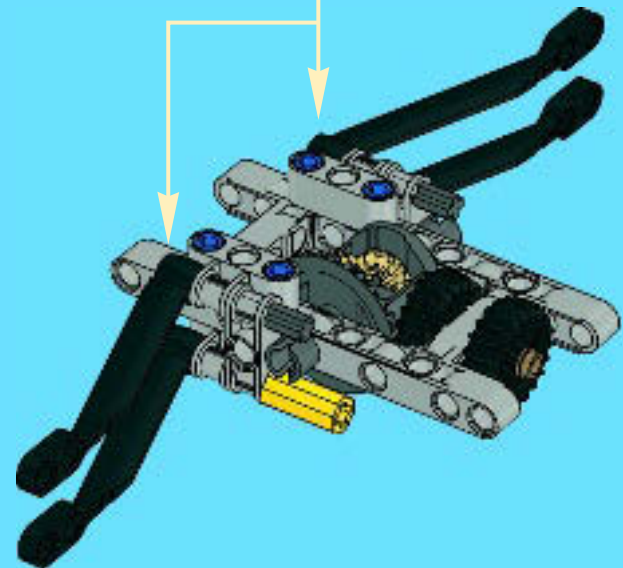
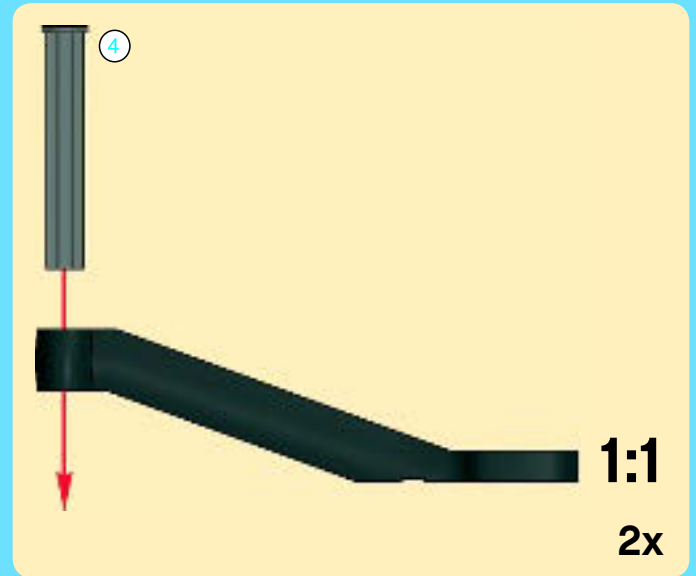



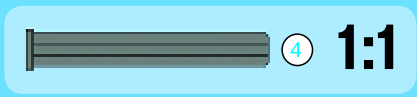
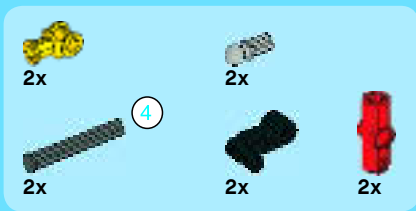

8

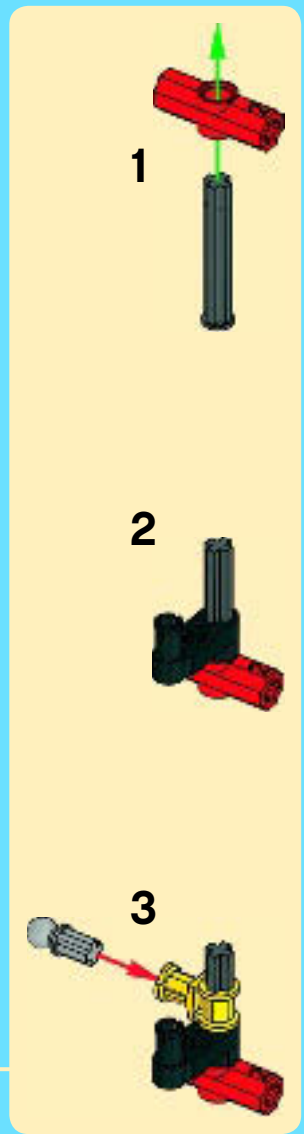
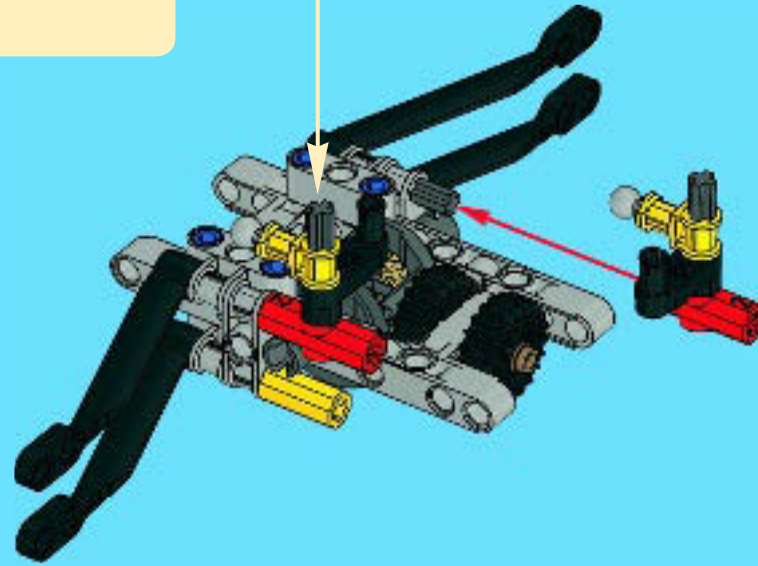
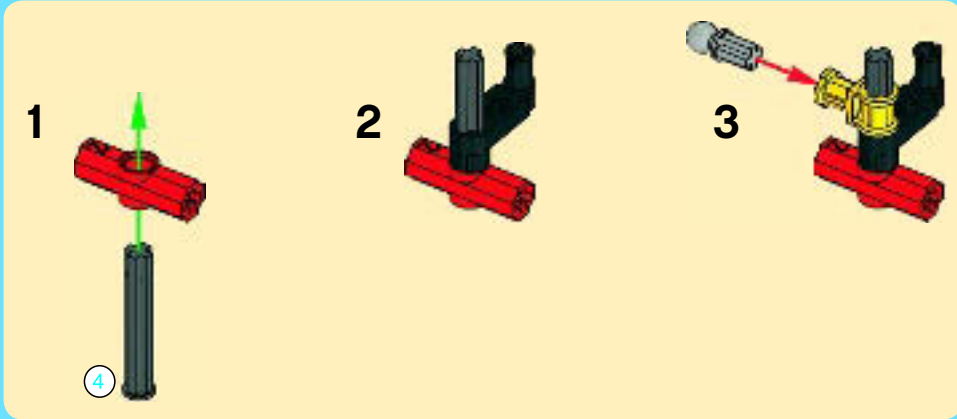

2x

2x

2x

9

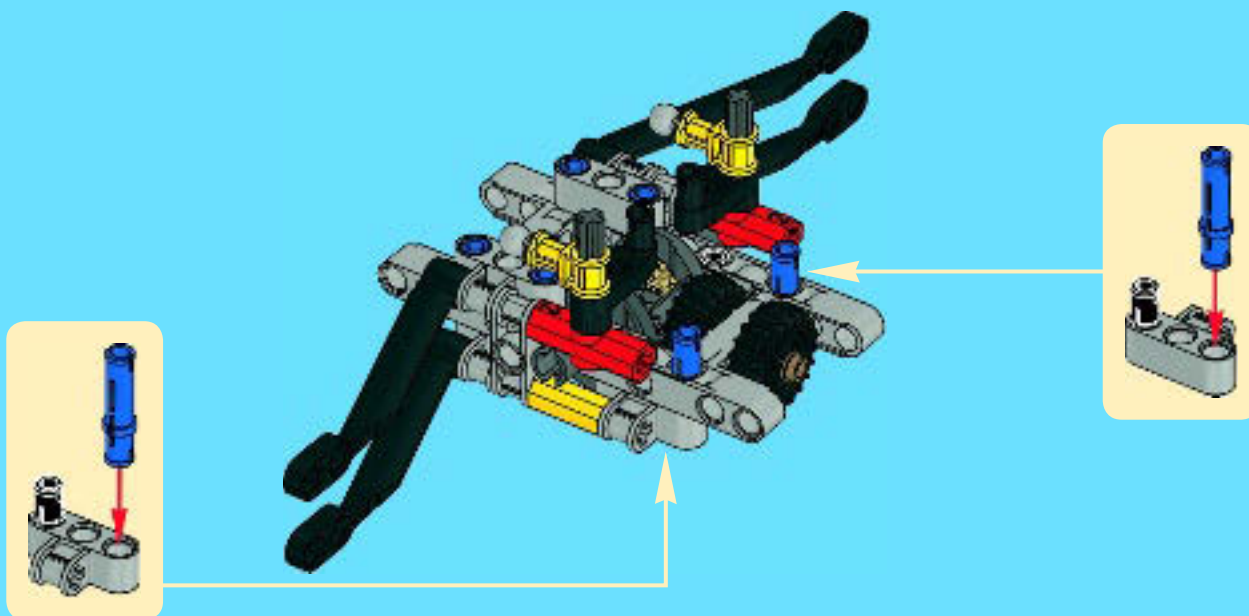

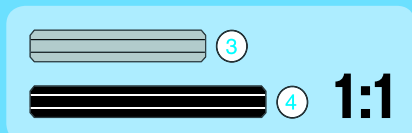

10

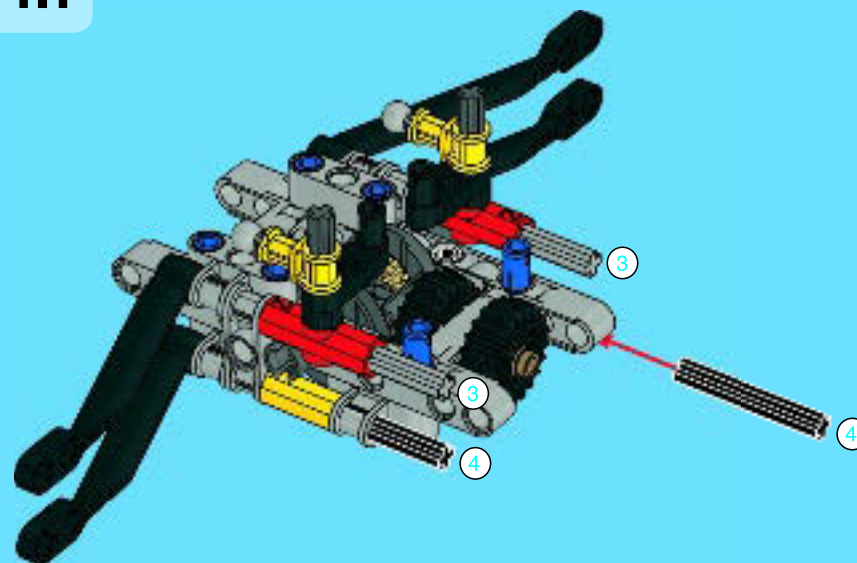

11

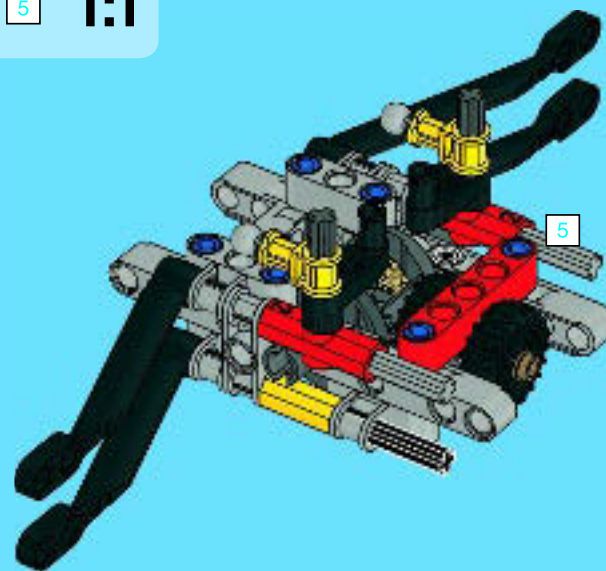

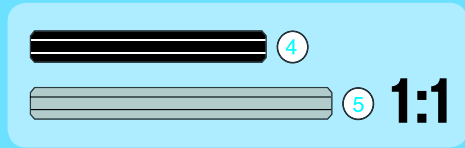
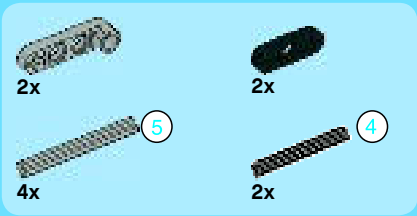

# 12

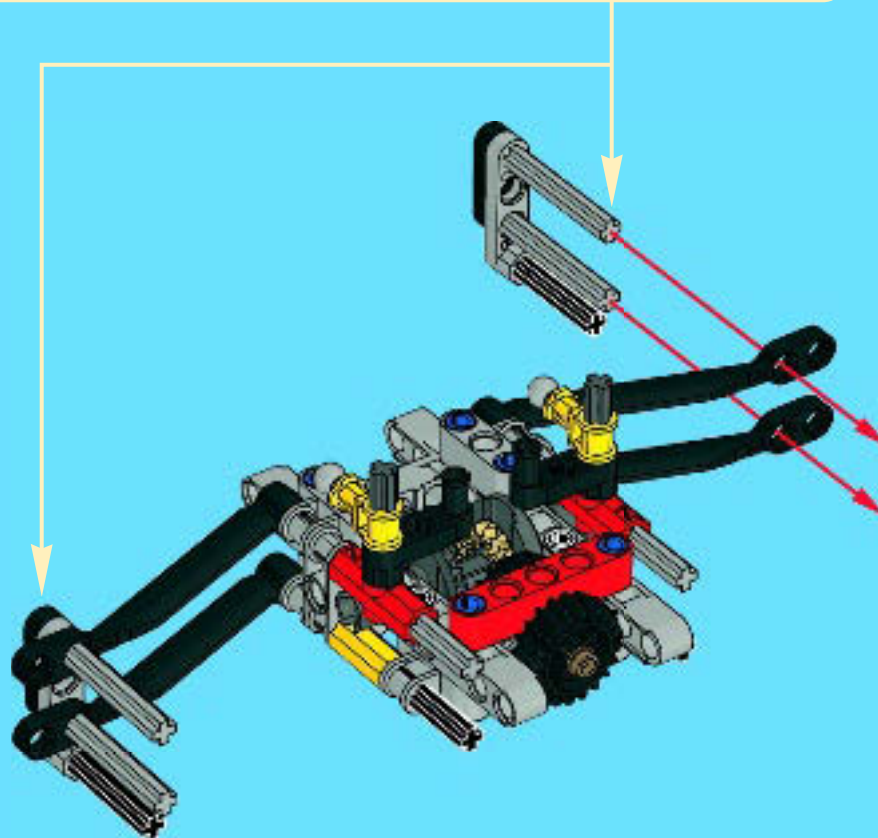
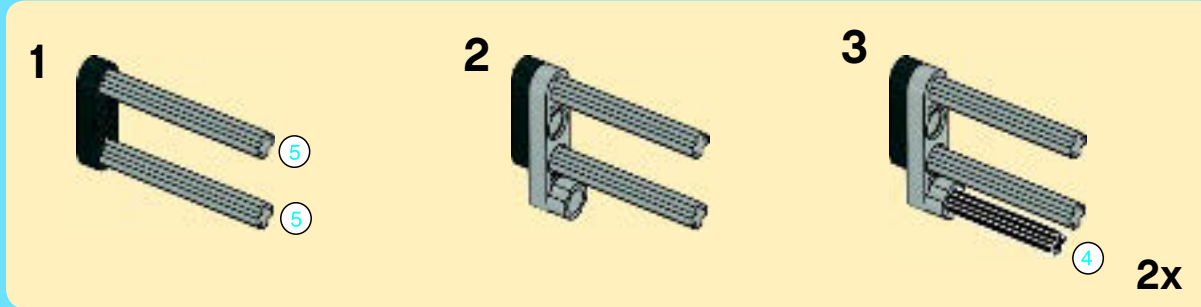



13

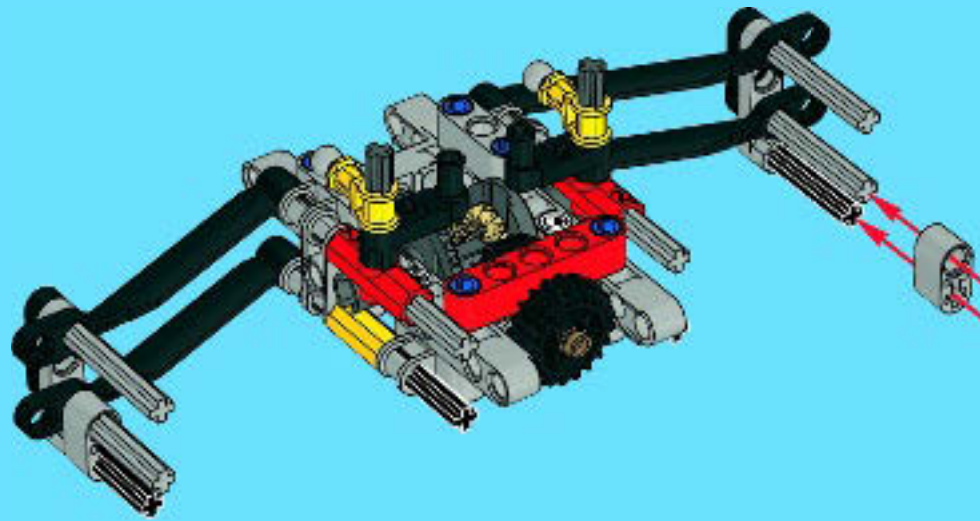

14

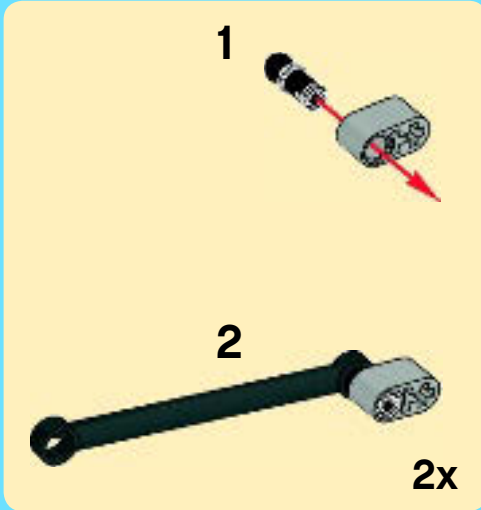
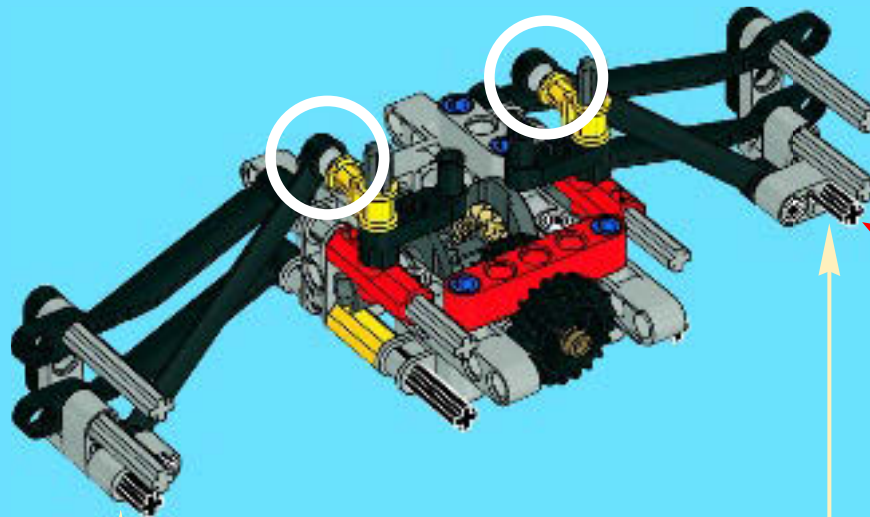



2x

15

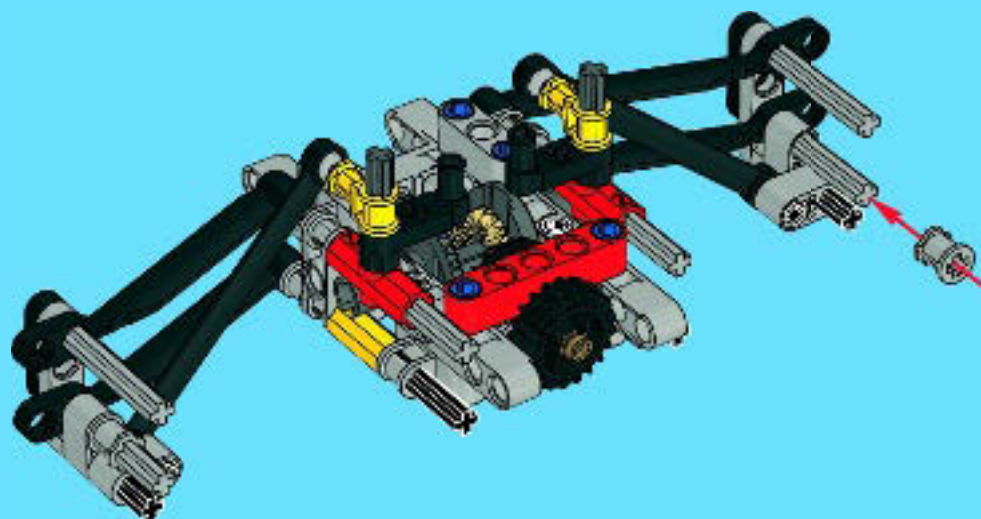

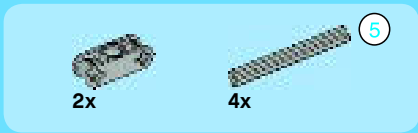

16

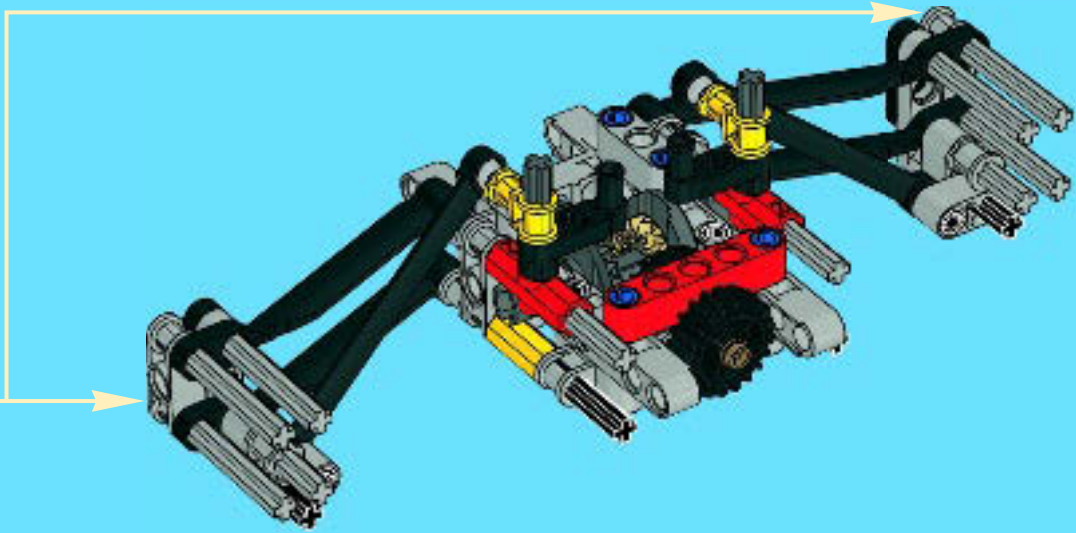
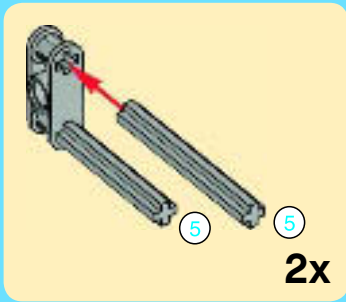

17

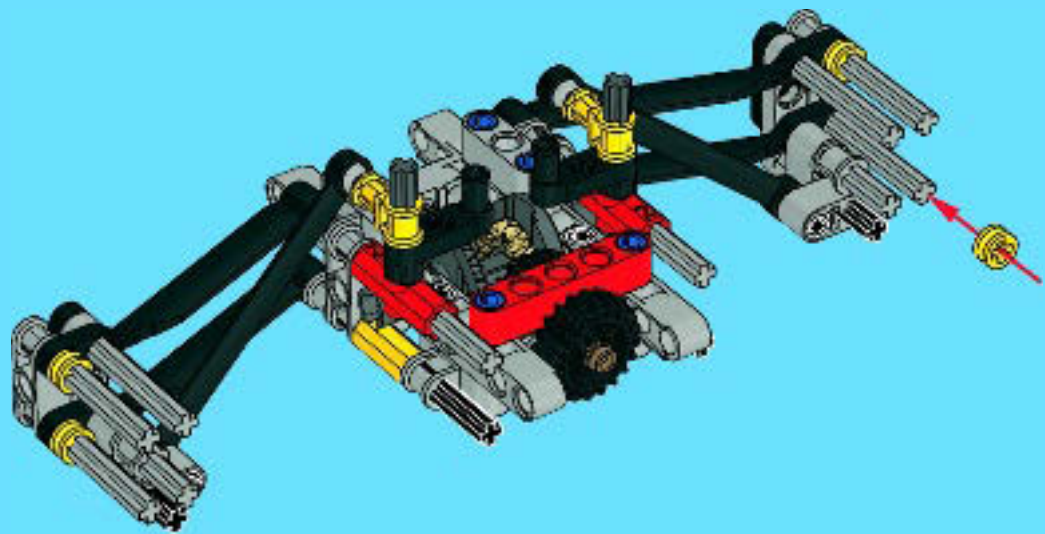

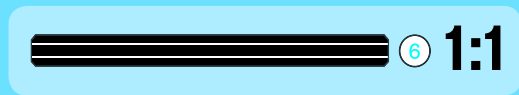
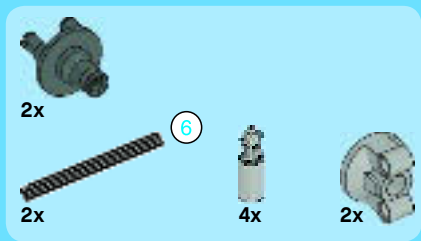

18

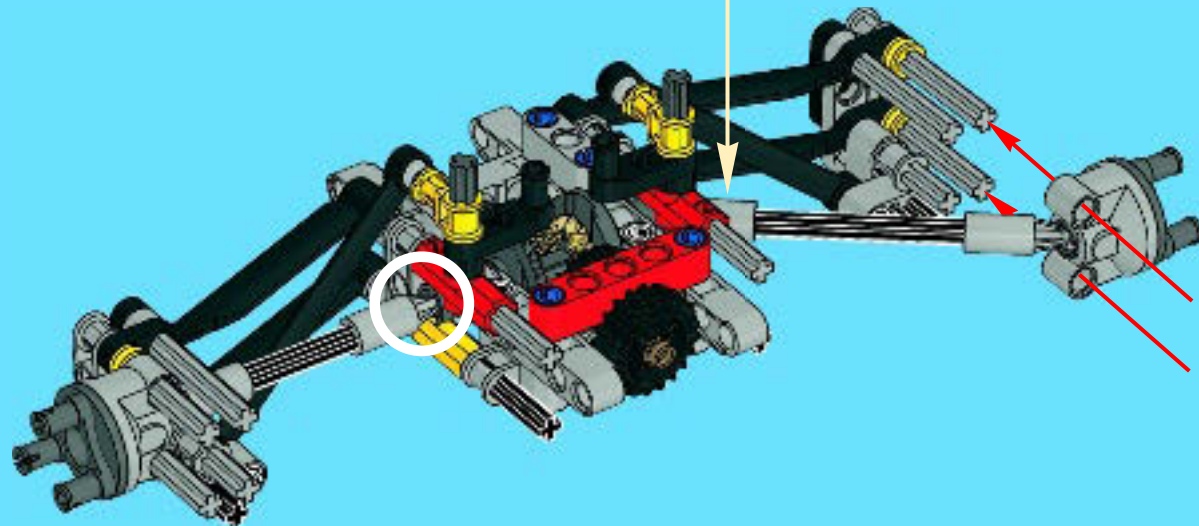
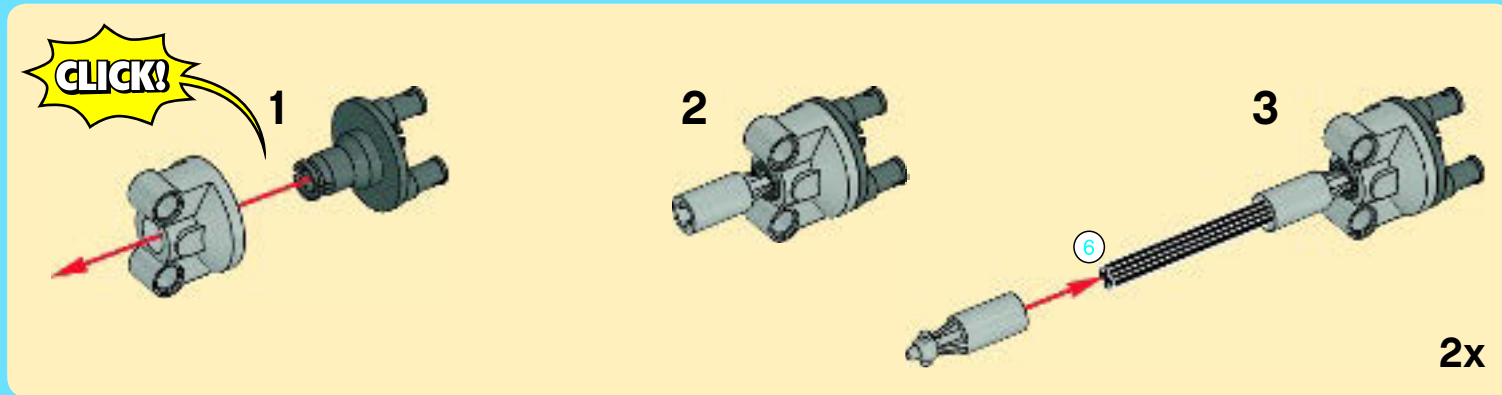





4x

19

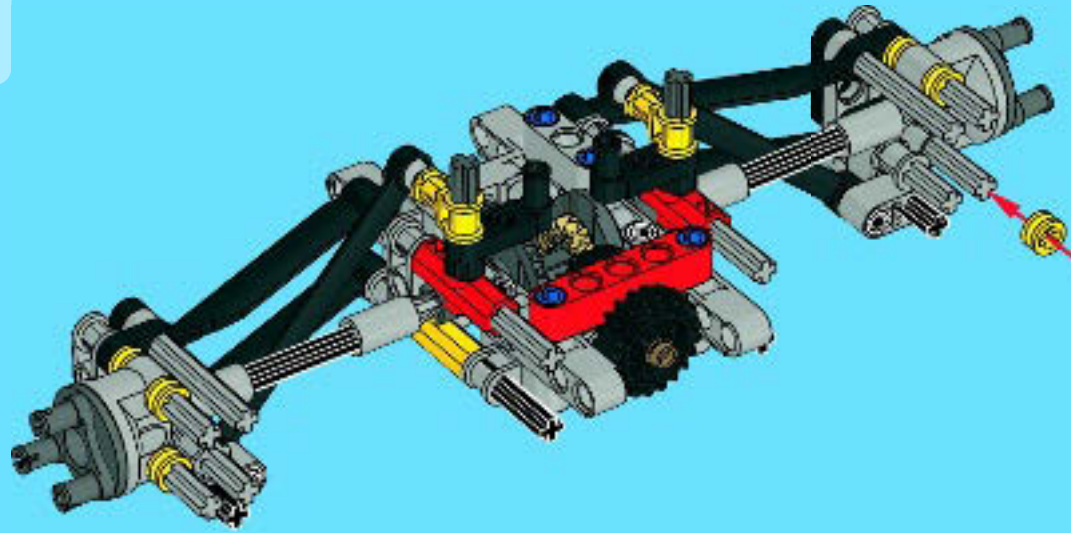

2x

20

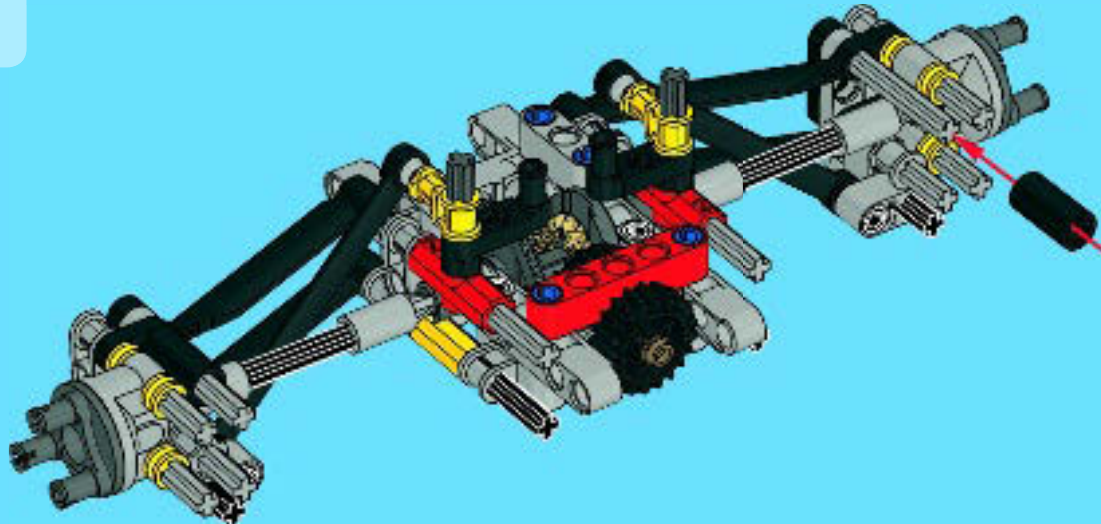



21

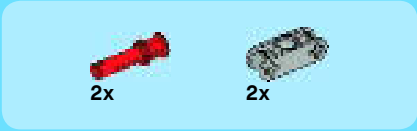
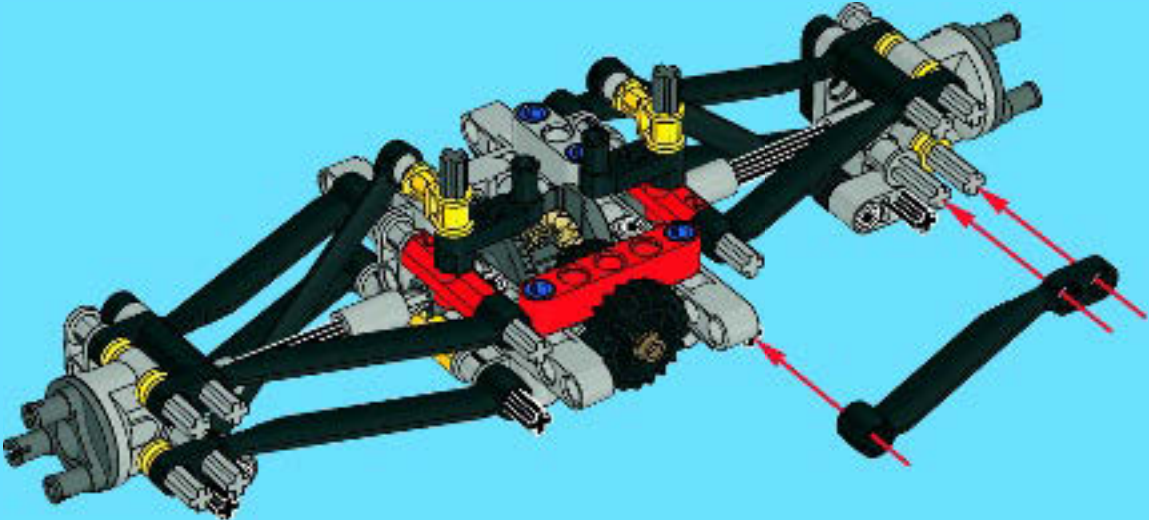

22

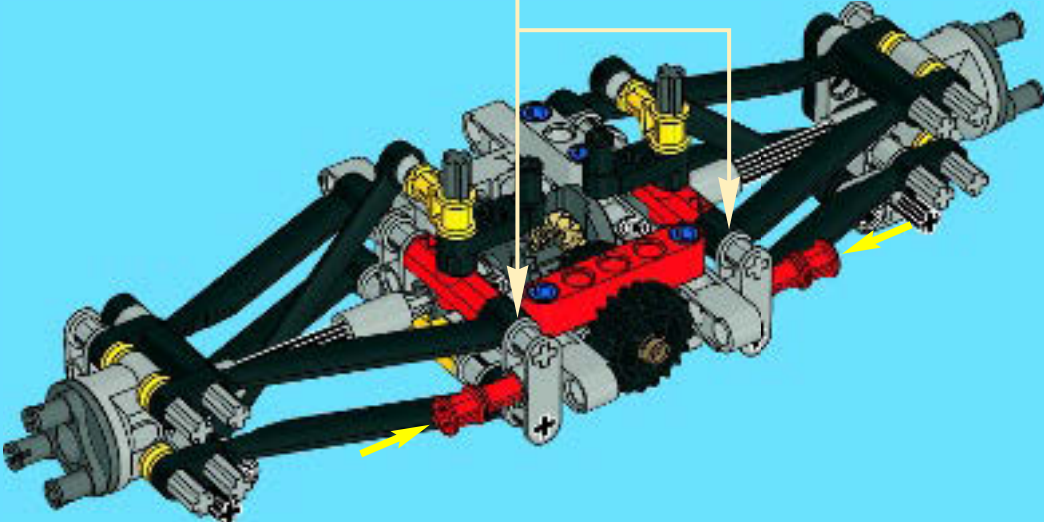
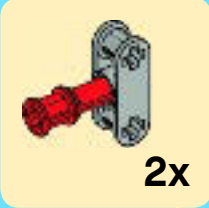



23

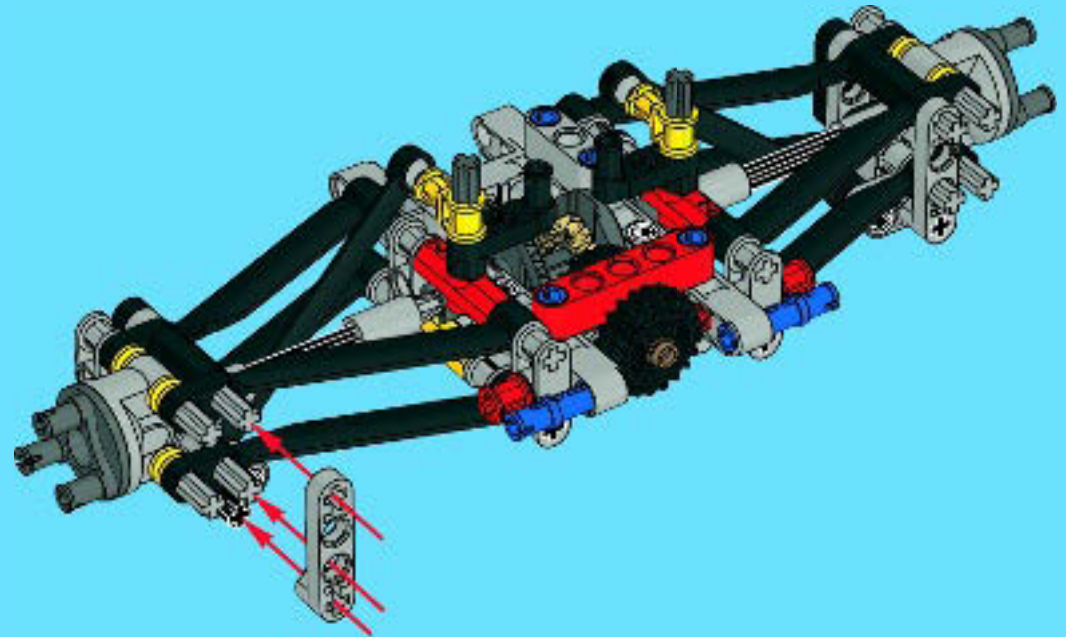

24

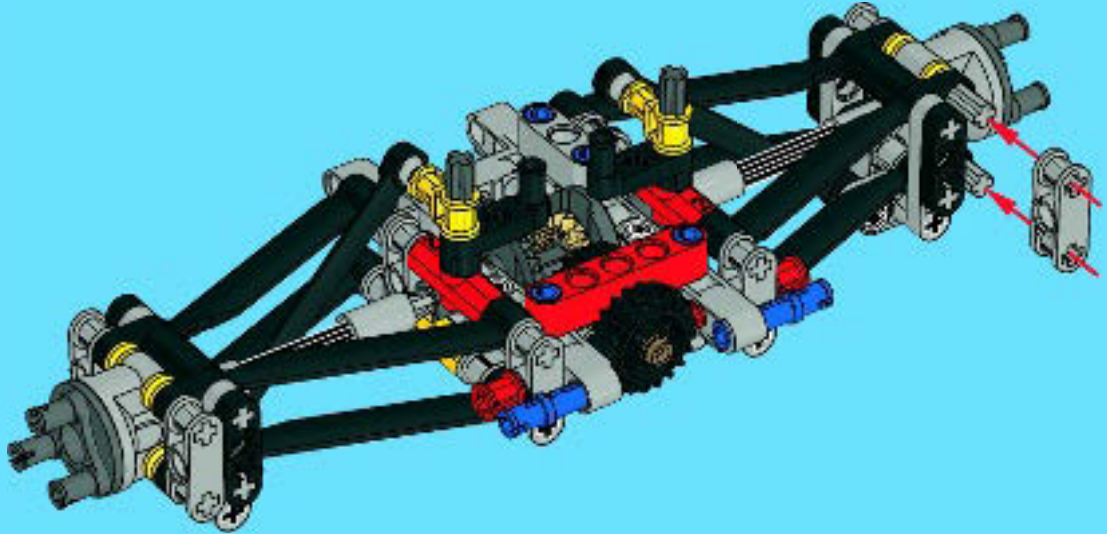

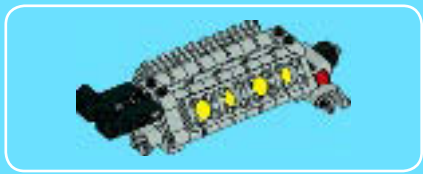

1

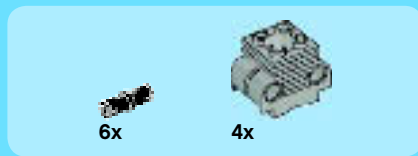
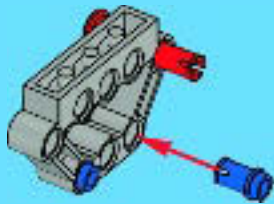

2

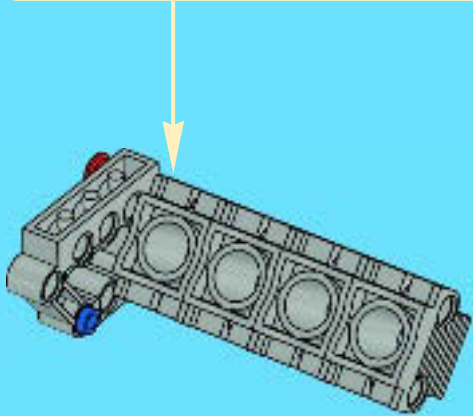
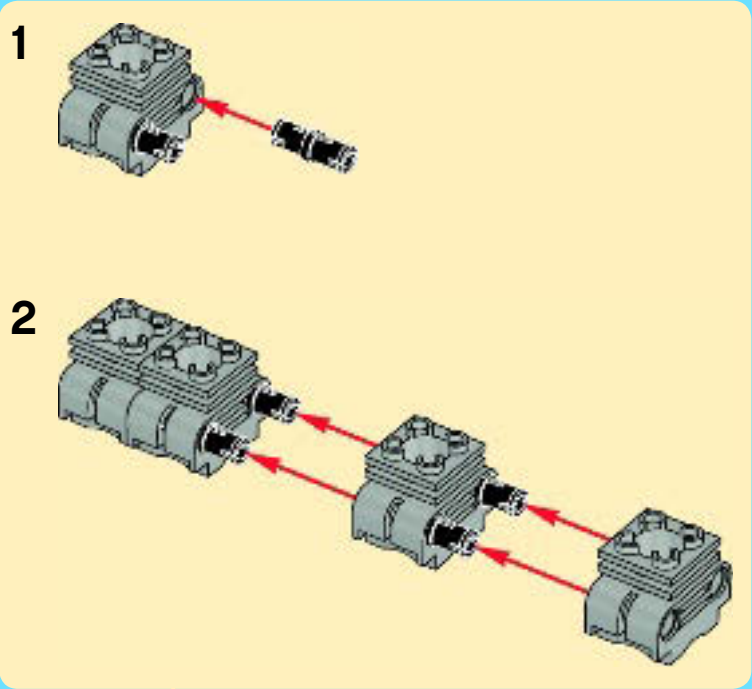

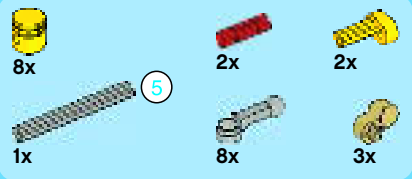

3

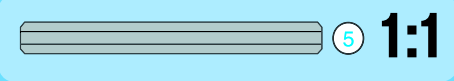
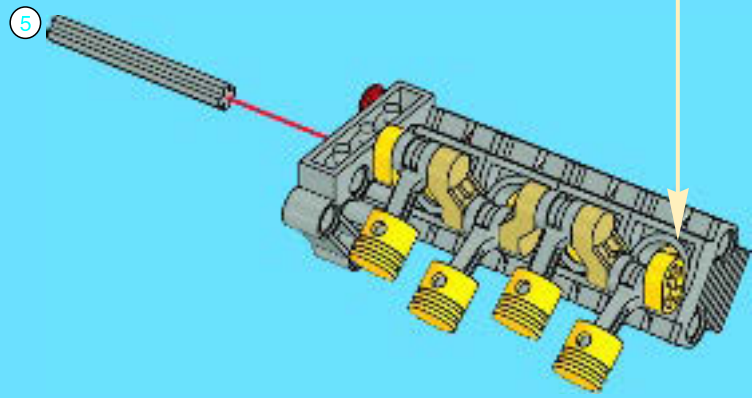
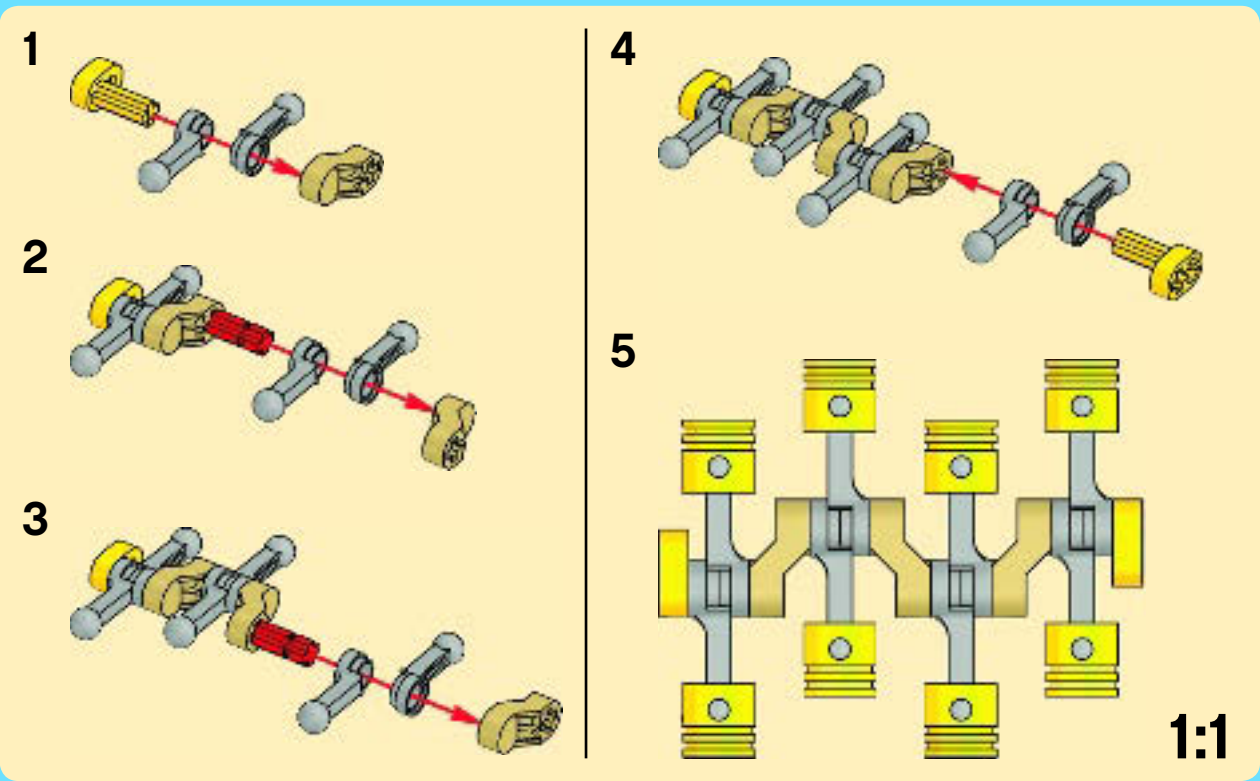



4

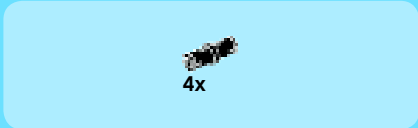
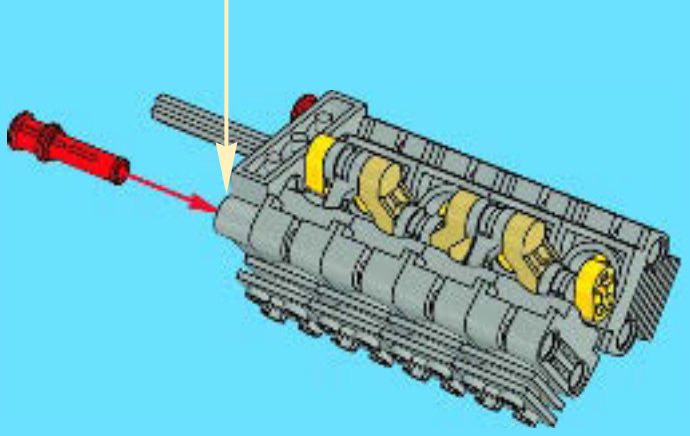
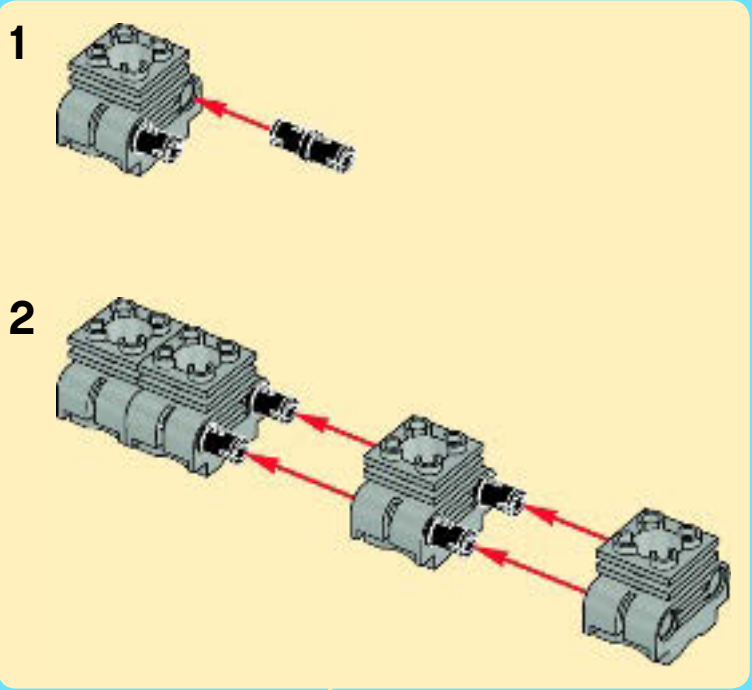

5

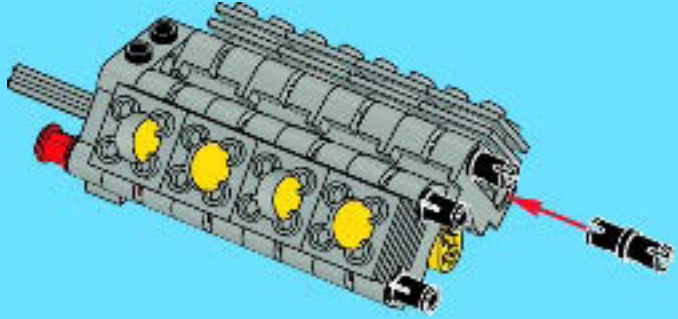

6

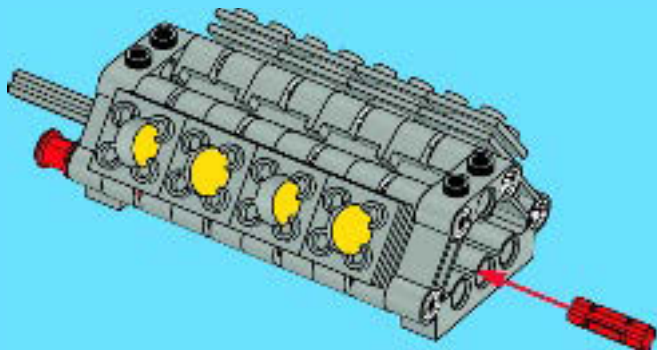

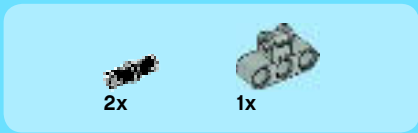

7

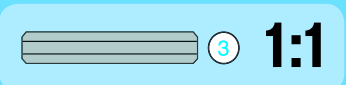
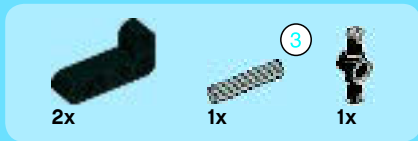
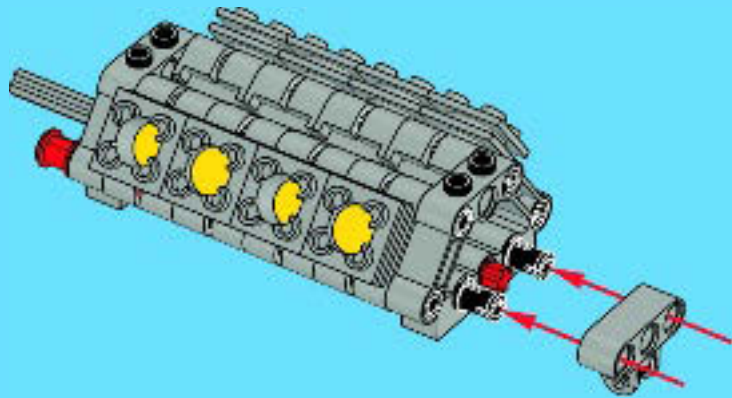

8

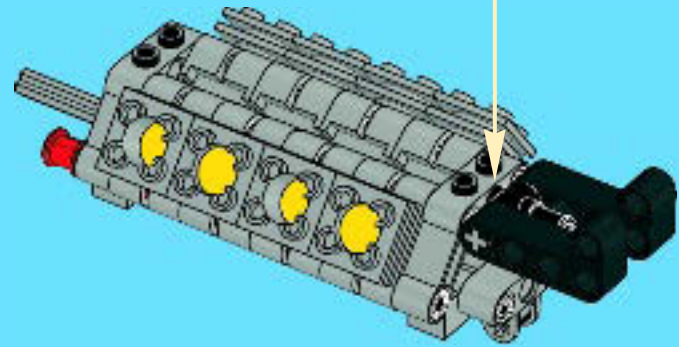

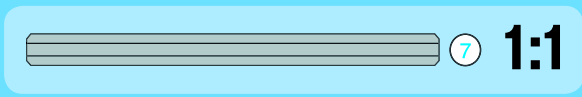
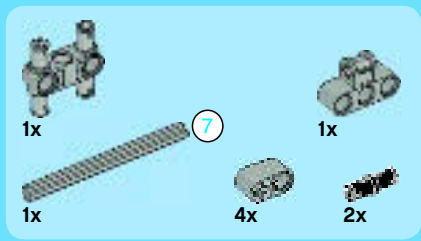

9

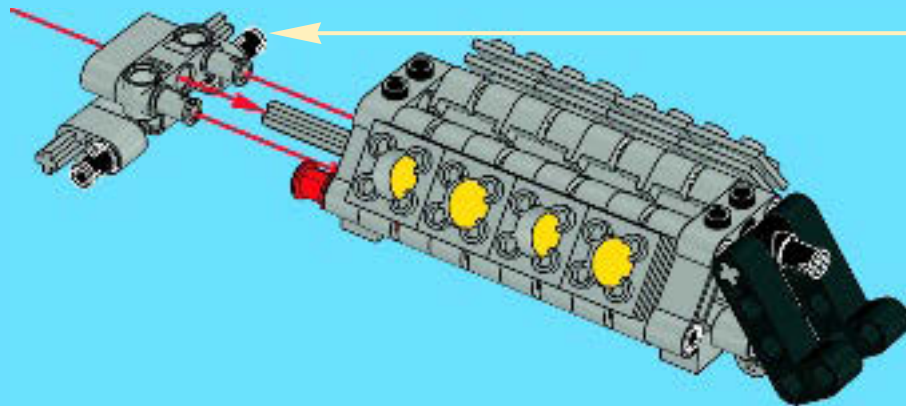
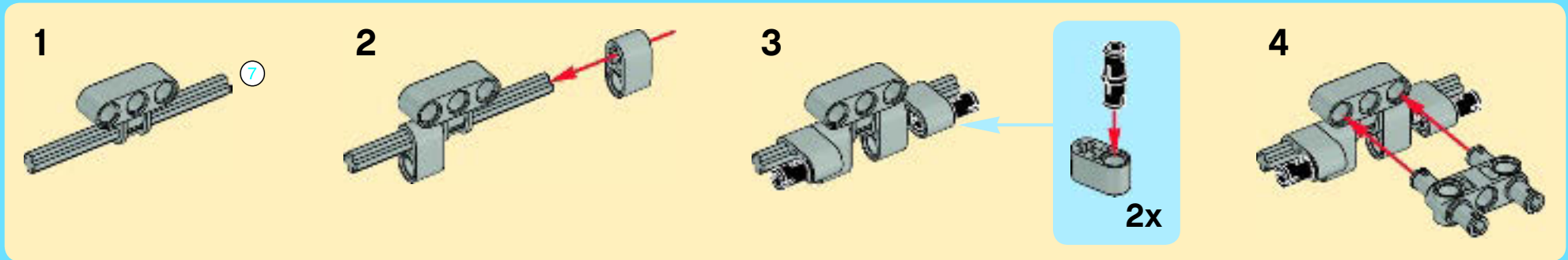





10

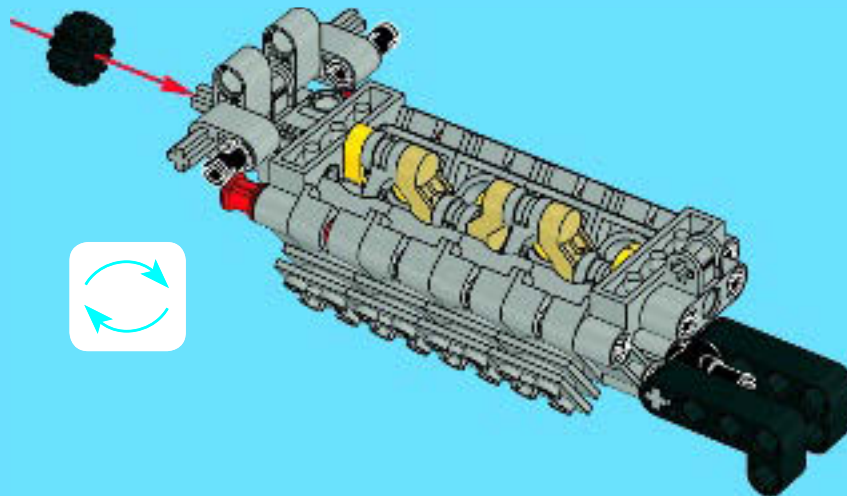

25

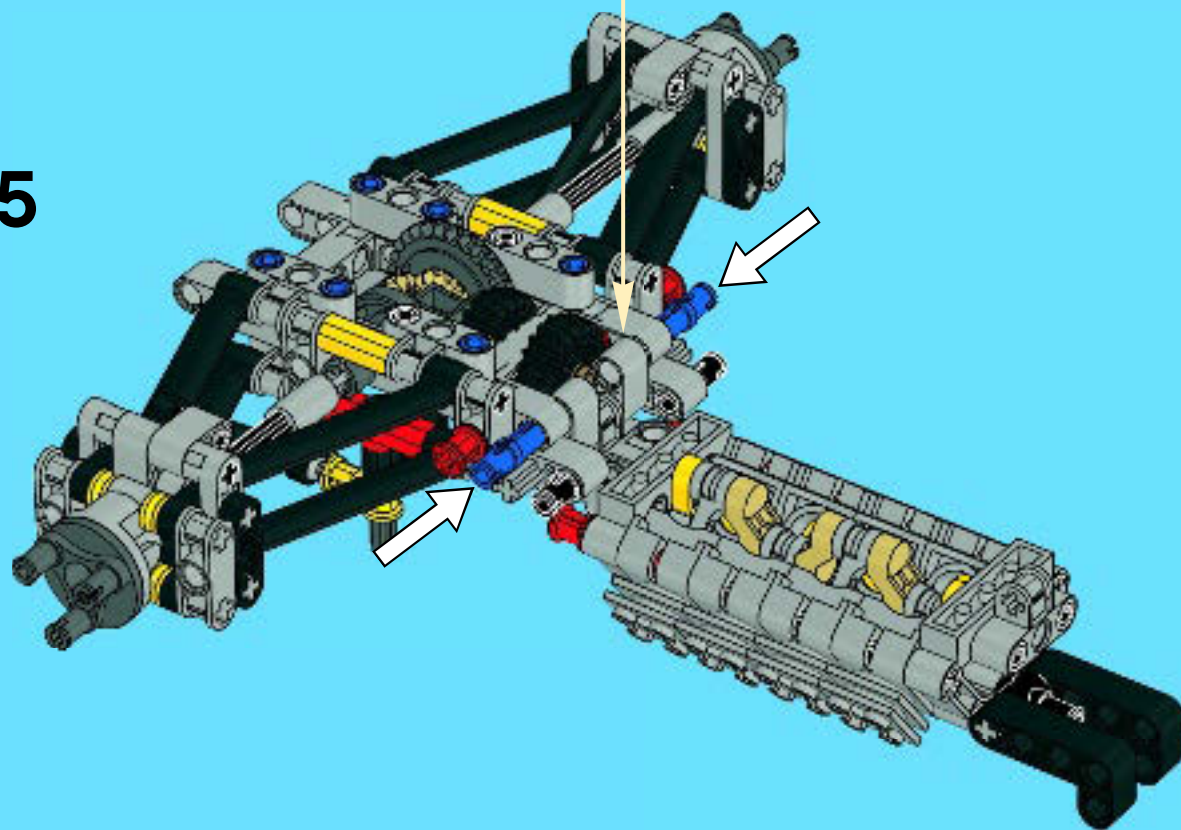

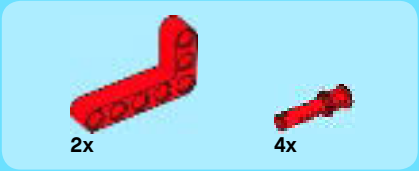

26

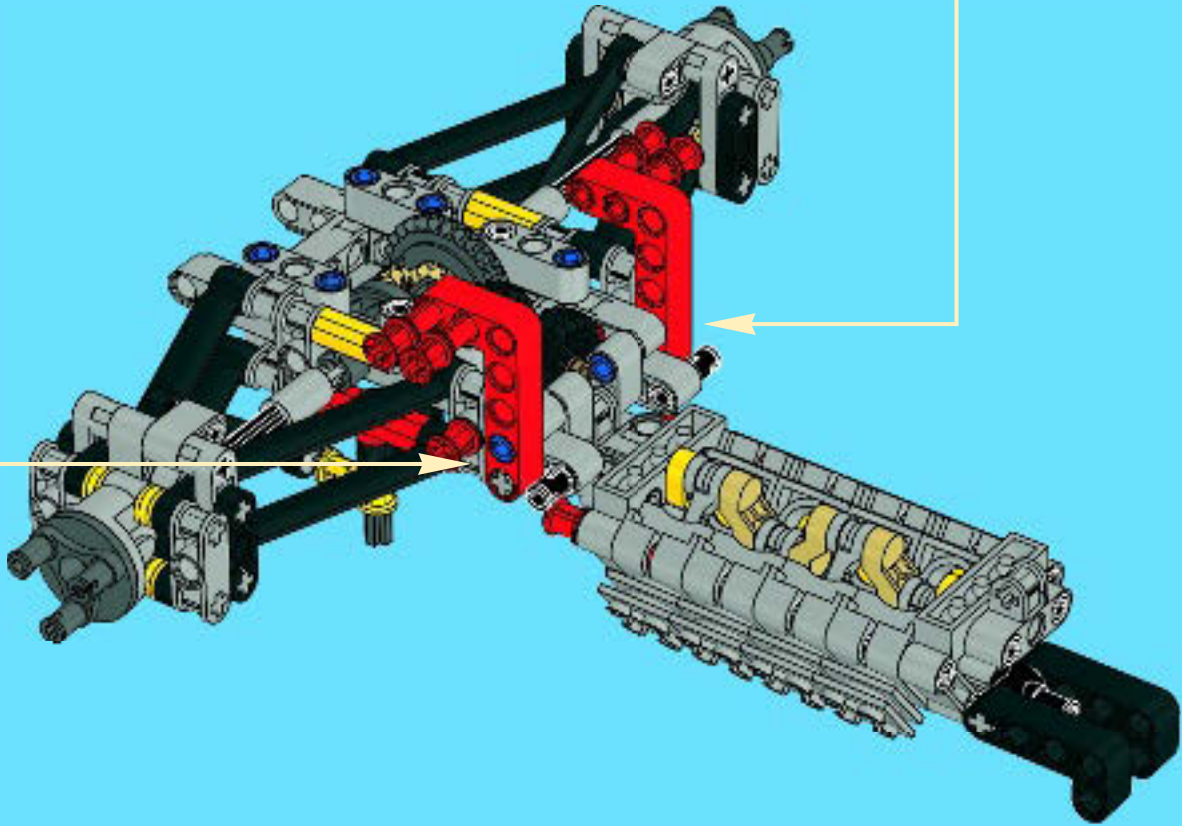



27

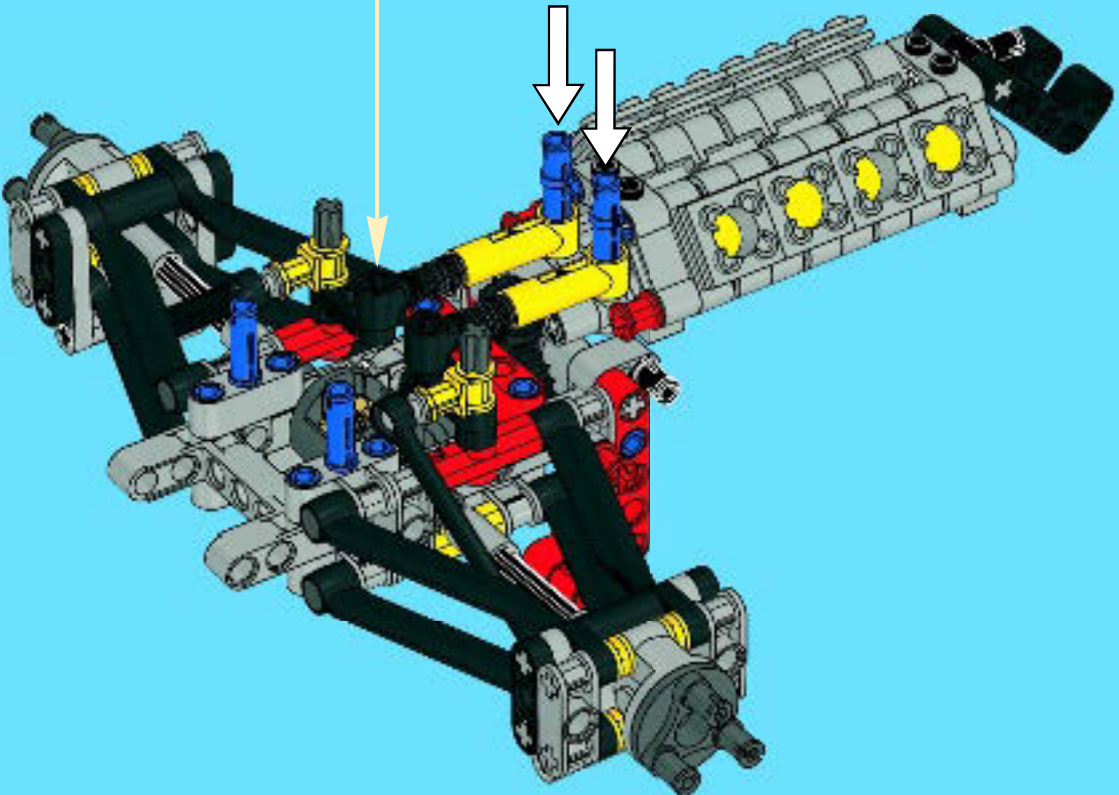
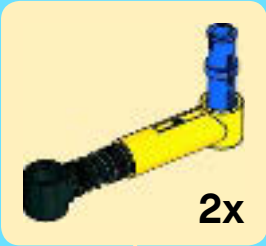



28

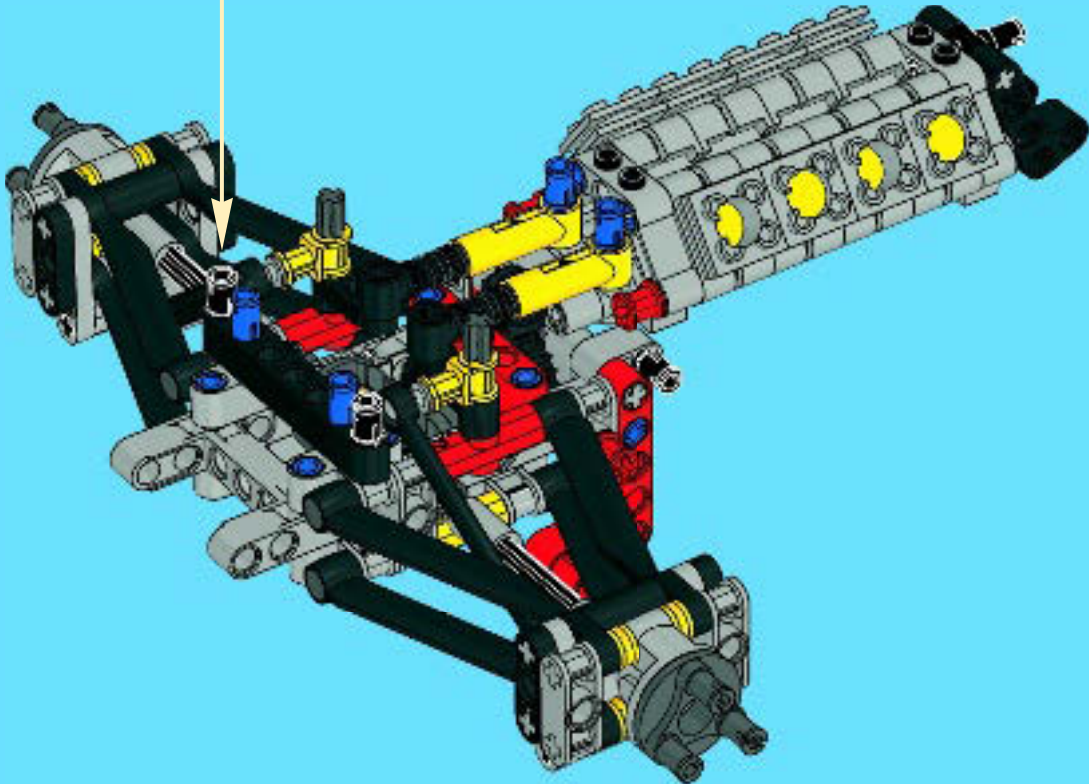
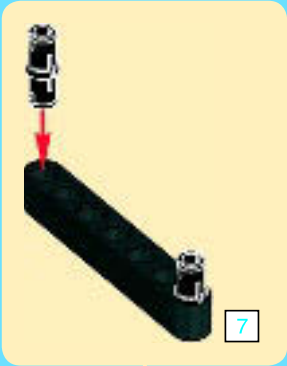

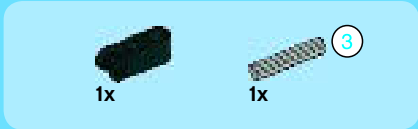

1



2

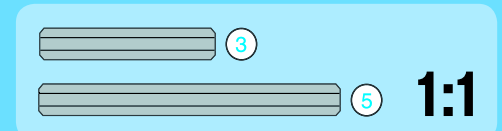
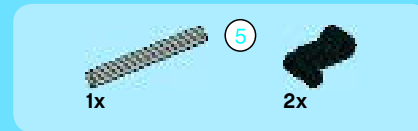

3

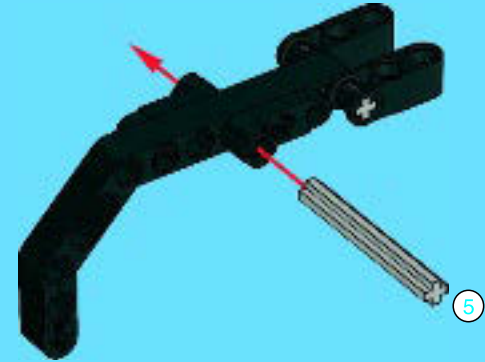

4





2x

1x

5

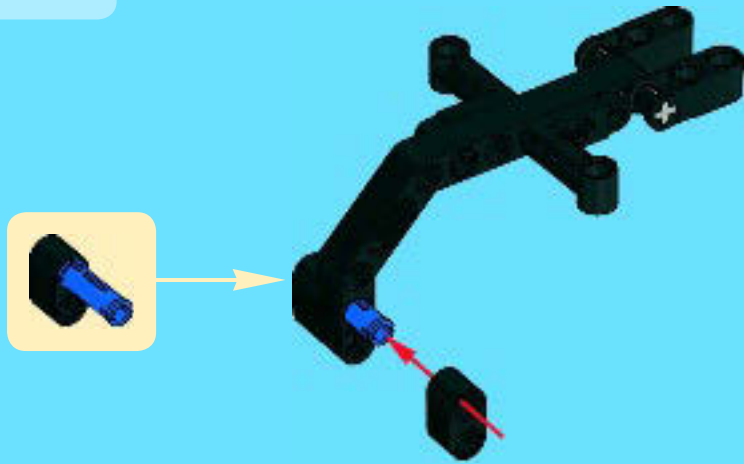

29



1x

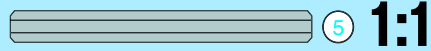

5

1:1

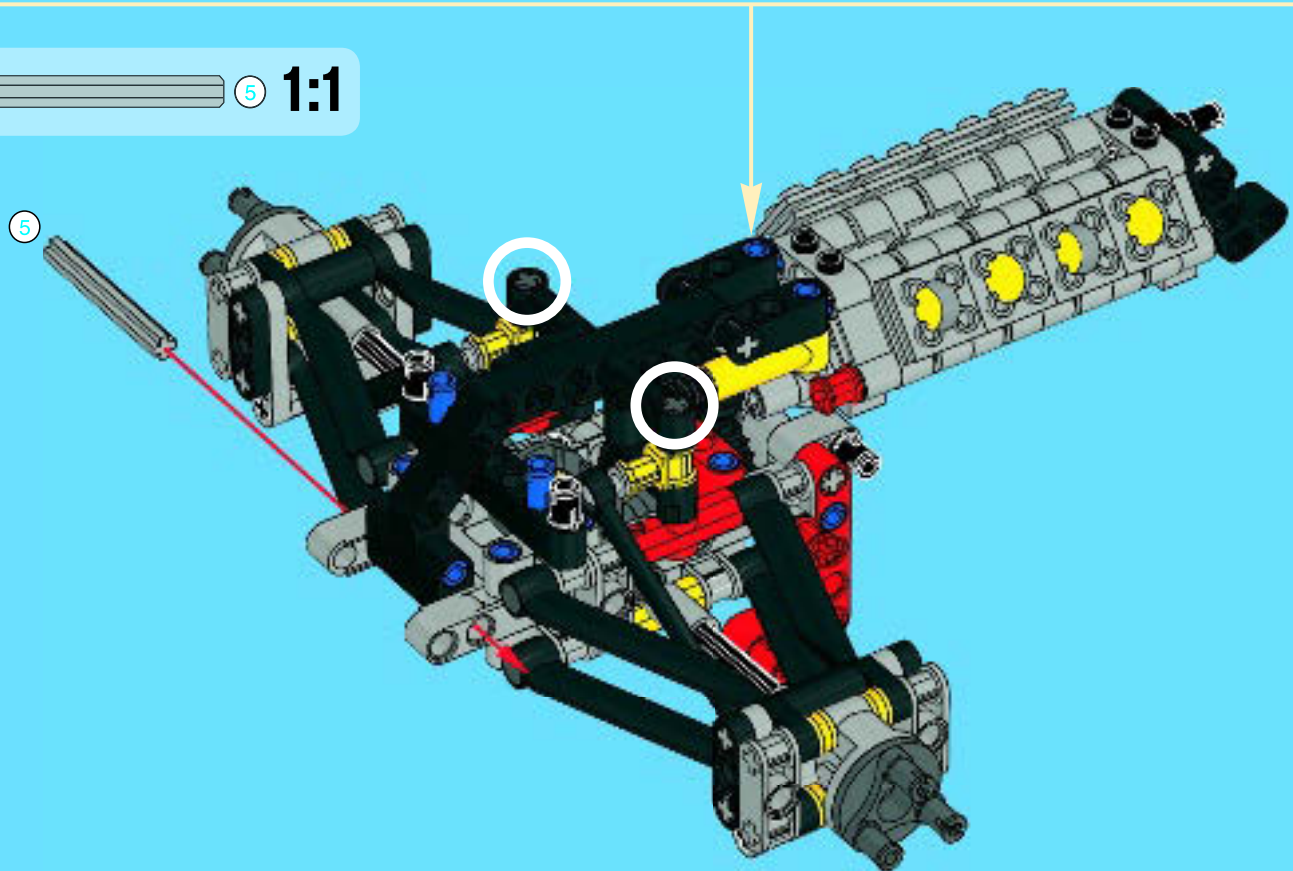

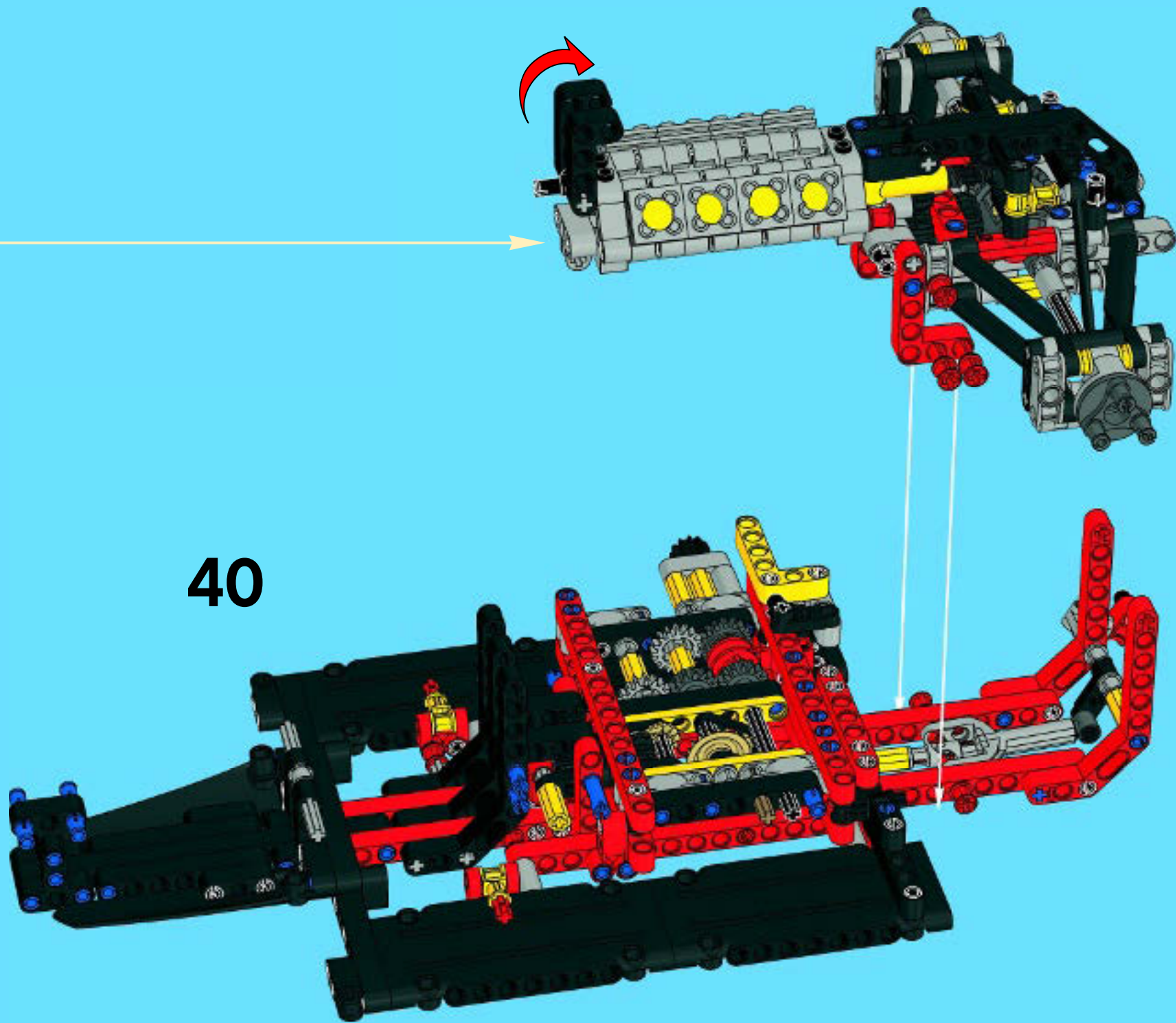

40

41

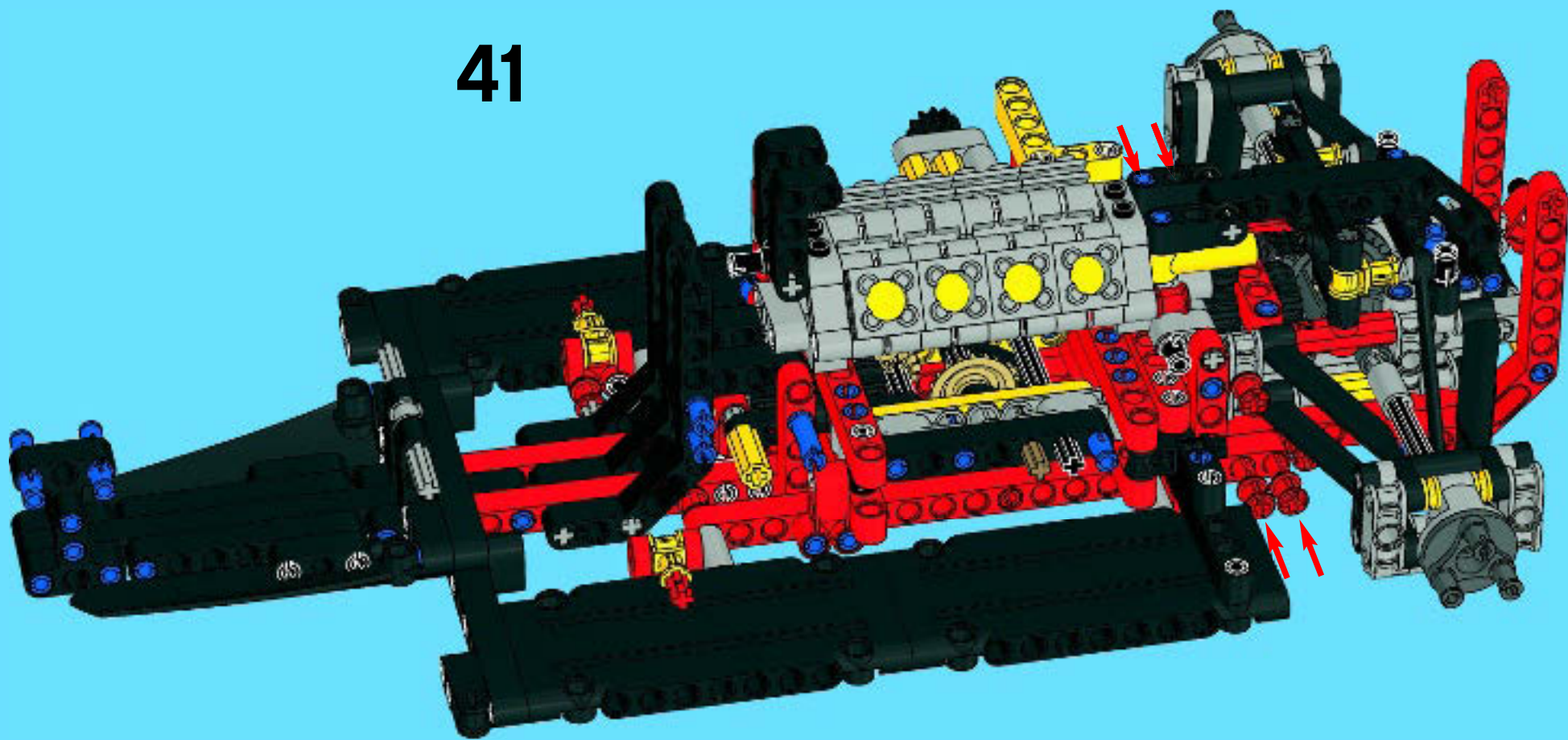



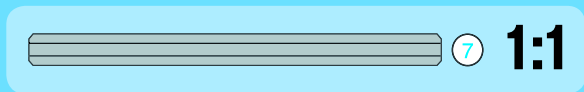
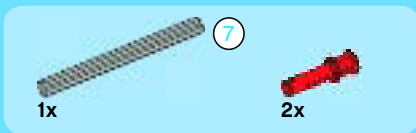

42

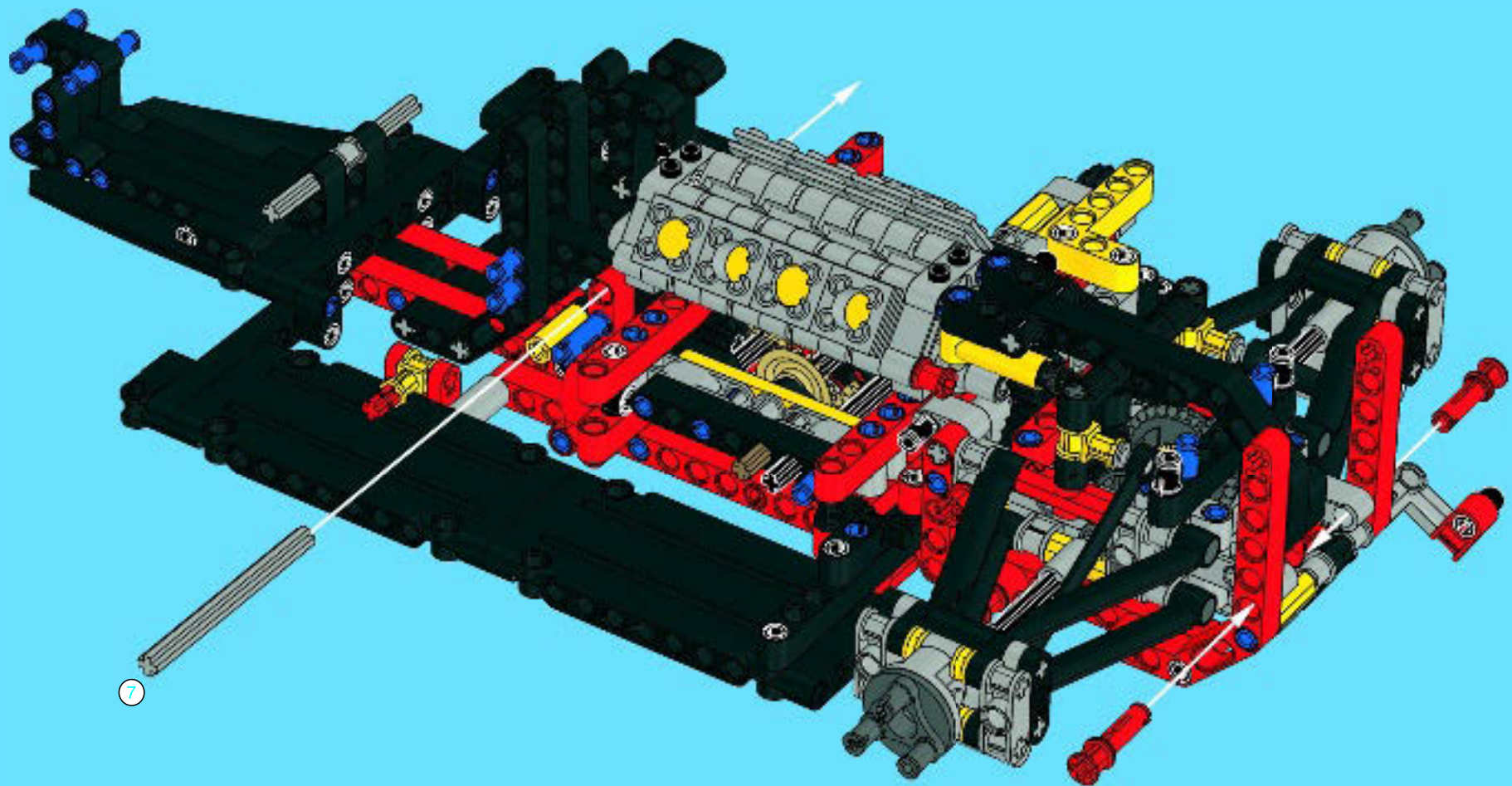



43

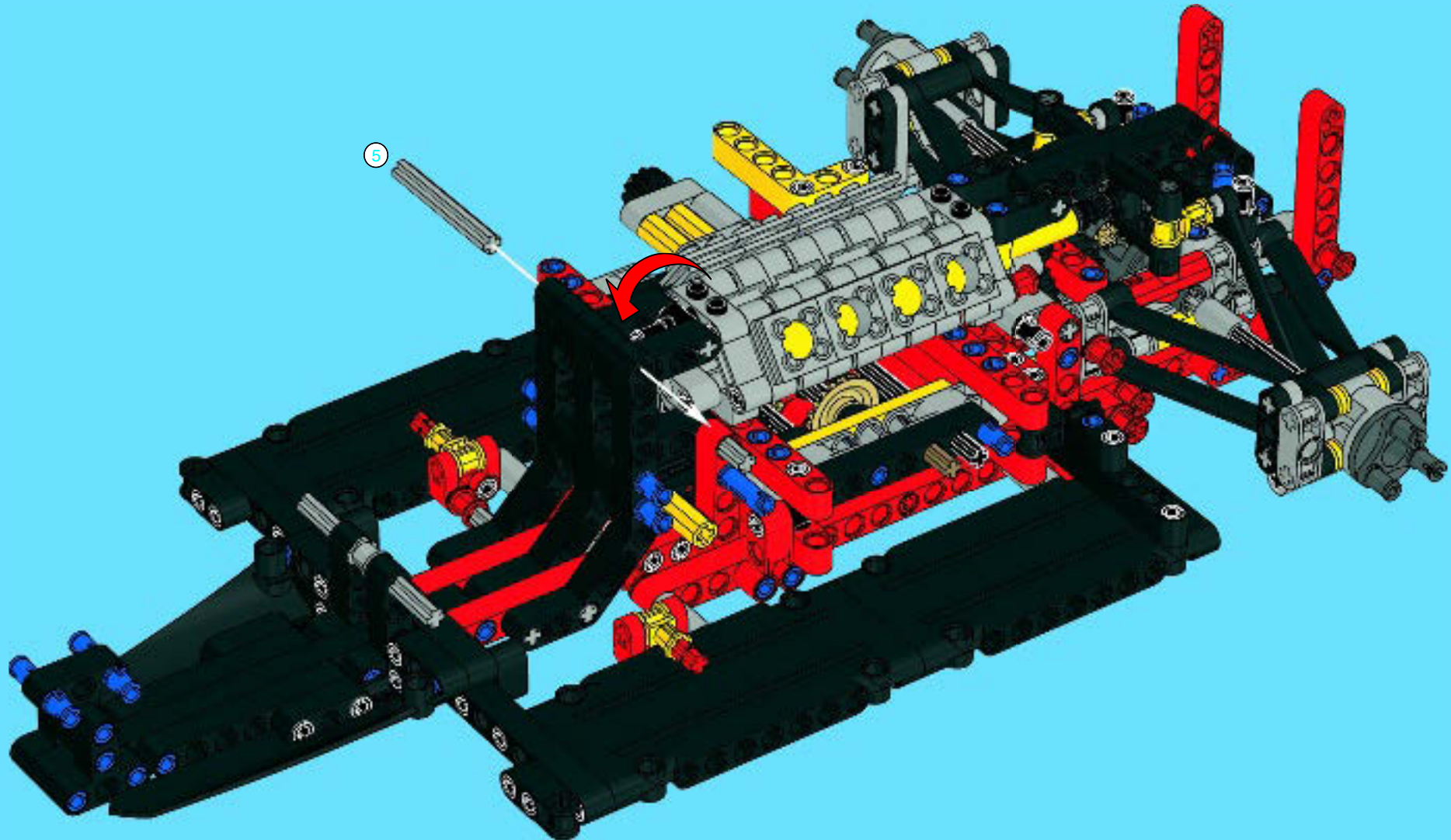

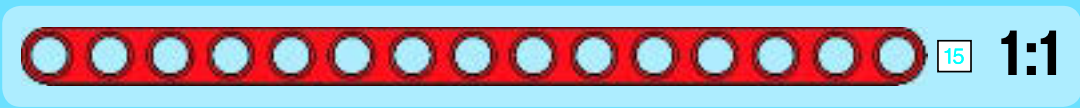

44

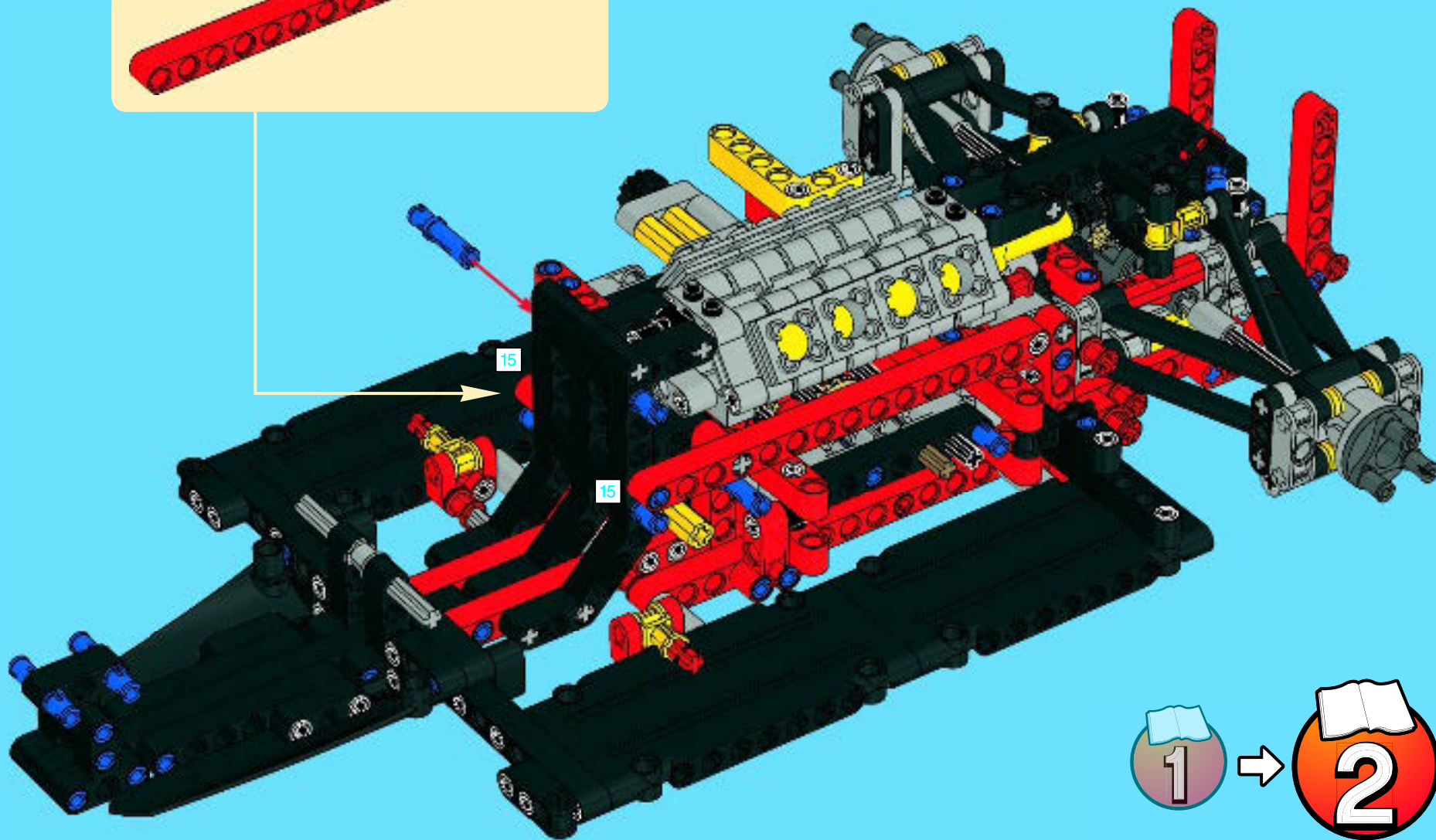



# WIN!

Go to [www.LEGOsurvey.com/product](http://www.LEGOsurvey.com/product) to fill out a survey for a chance to win a cool LEGO® Product. No purchase necessary. Open to all residents where not prohibited.

 [LEGO.com](http://LEGO.com)



## [www.LEGOsurvey.com/product](http://www.LEGOsurvey.com/product)

### GEWINNE!

Nimm an der Umfrage auf [www.LEGOsurvey.com/product](http://www.LEGOsurvey.com/product) teil und hab die Chance ein cooles LEGO® Produkt zu gewinnen! Die Teilnahme am Gewinnspiel führt zu keinerlei Kaufverpflichtungen. Teilnahme in allen nicht ausgeschlossenen Ländern möglich.

### WIN!

Ga naar [www.LEGOsurvey.com/product](http://www.LEGOsurvey.com/product), vul een enquêteformulier in en maak kans op een cool LEGO® product. Geen aankoopverplichting. Iedereen mag deelnemen, uitgezonderd ingezetenden van landen waar een enquêteverbod geldt.

### GAGNE!

Visite [www.LEGOsurvey.com/product](http://www.LEGOsurvey.com/product) pour répondre à un questionnaire et avoir une chance de gagner un produit LEGO® très cool ! Aucune obligation d'achat. Ouvert à tous les résidents des pays autorisés.

### 当てよう!

[www.LEGOsurvey.com/product](http://www.LEGOsurvey.com/product) にアクセスして、アンケートにご記入ください。当選者にはレゴ製品を差し上げます。お買い上げの必要はありません。禁止されていない限り、すべての皆様にご利用いただけます。