

LEGO[®]

TECHNIC

42007



1



2



3



4



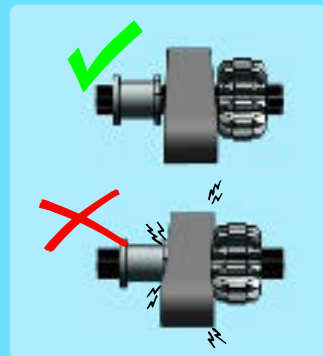
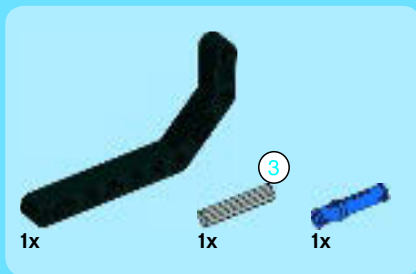

1

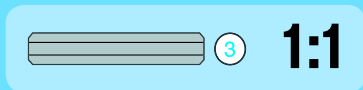

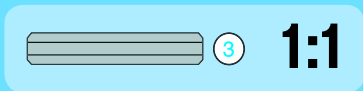

2

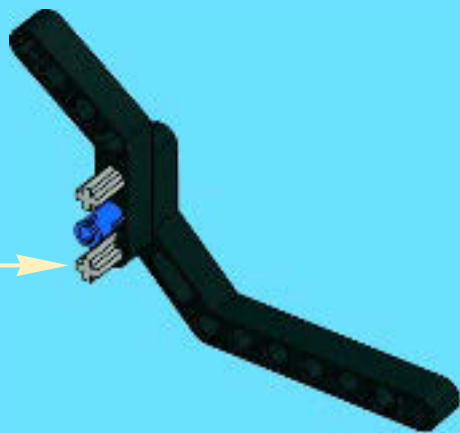

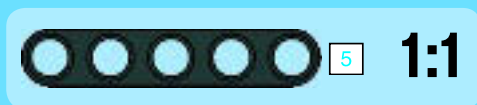

3

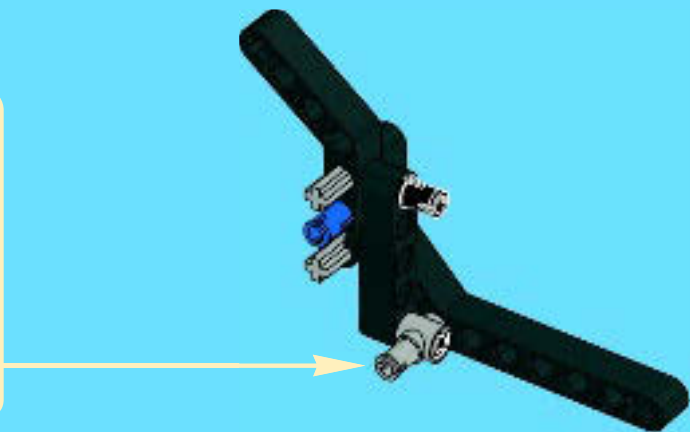
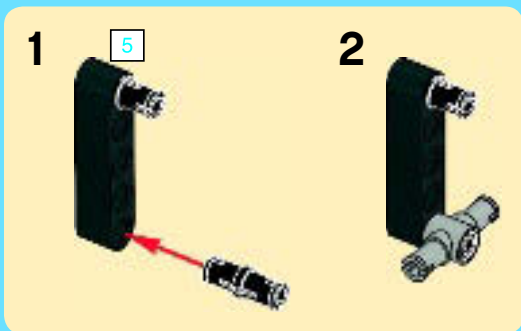



1x



1x

4

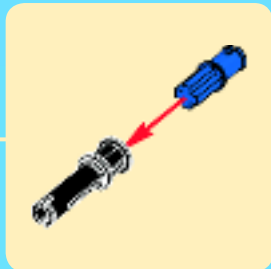
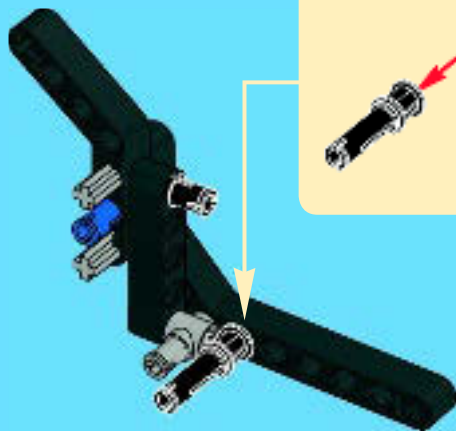

1x

8



1x



1x

5

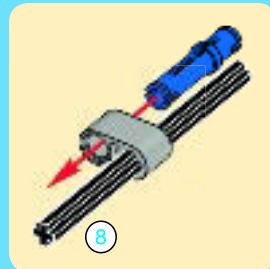

8

1:1



6

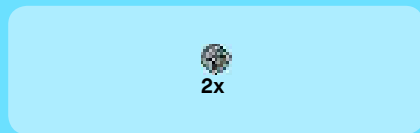

7





1x

1



2x

2

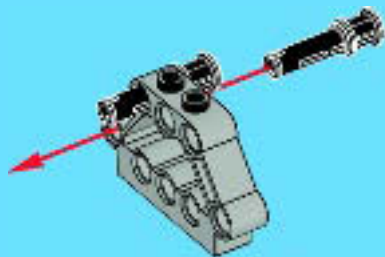



1x

3

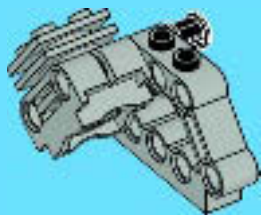

2x

4

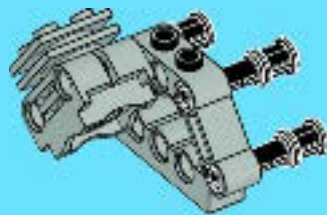



2x



2x



2x



1x

5

1



3



2

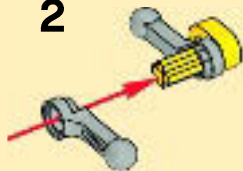

4



5

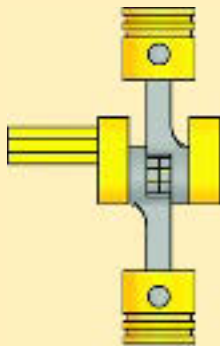

1:1

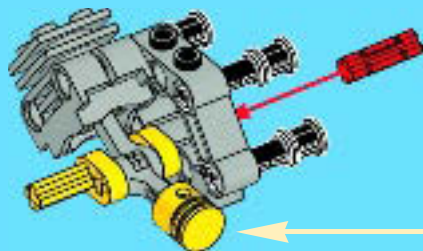



1x

6

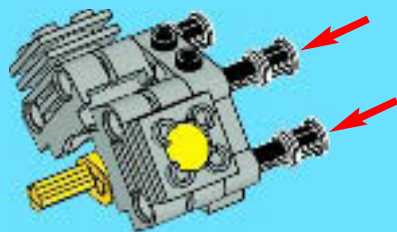

2x

7

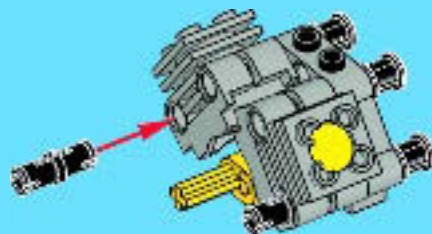



2x

8

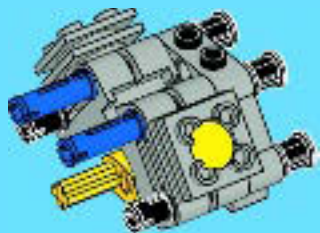

1x

9

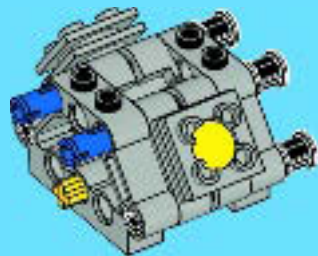



1x



1x

10

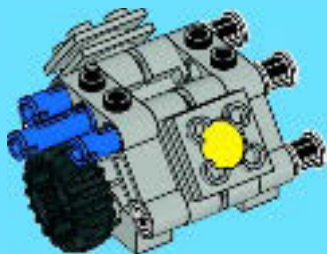

1x

11

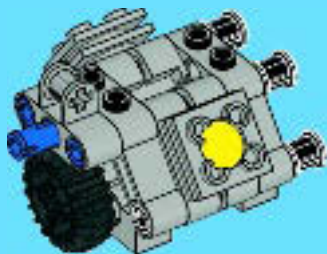



12



8

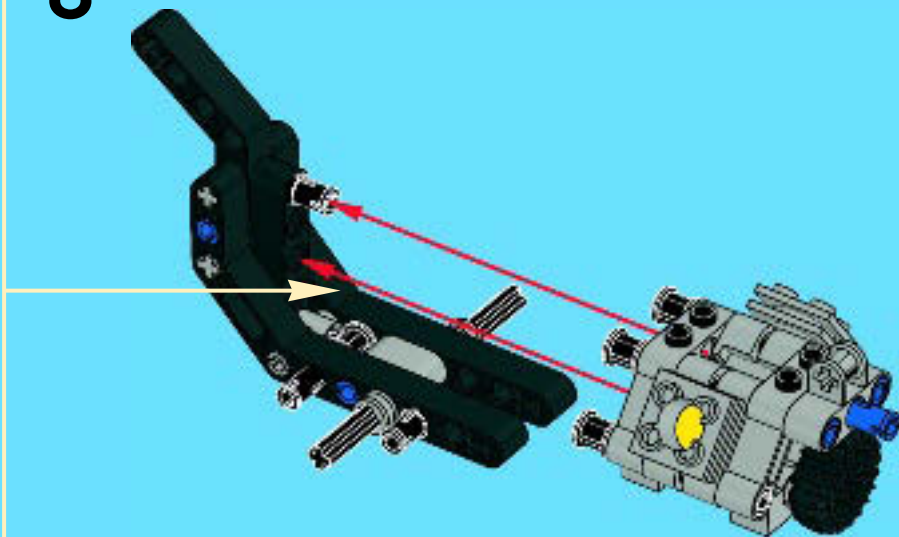

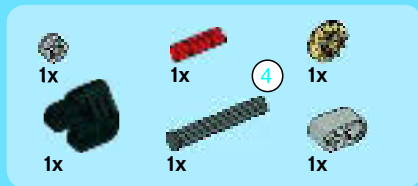

9

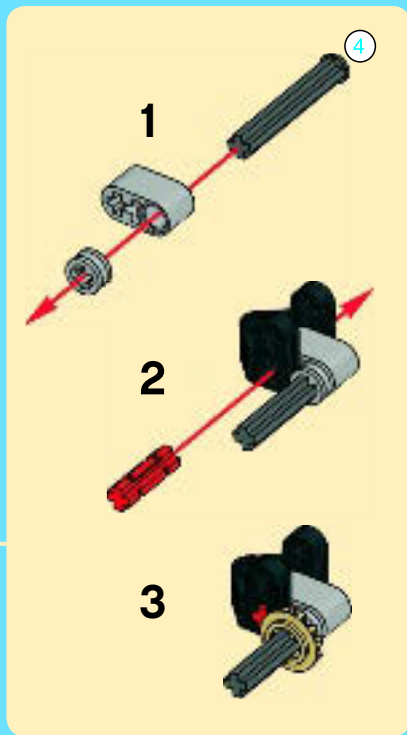

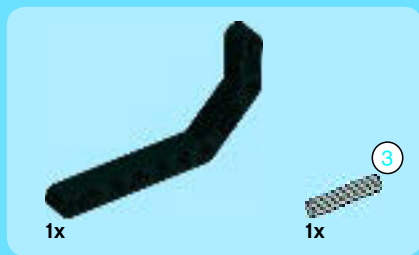

10

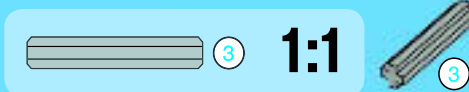
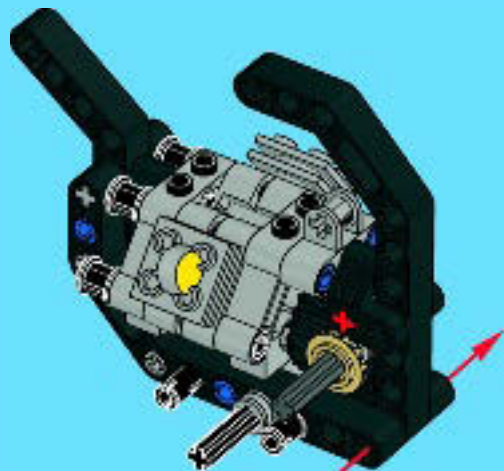

16



11

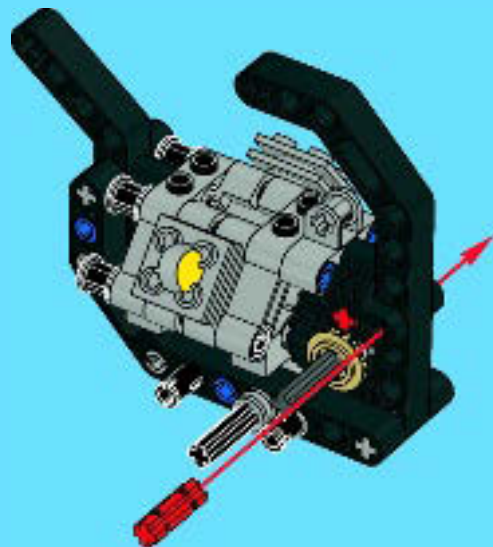

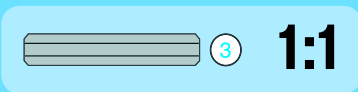
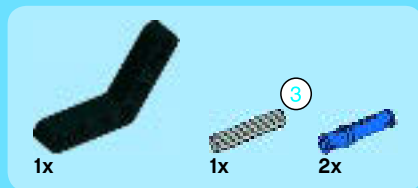

12

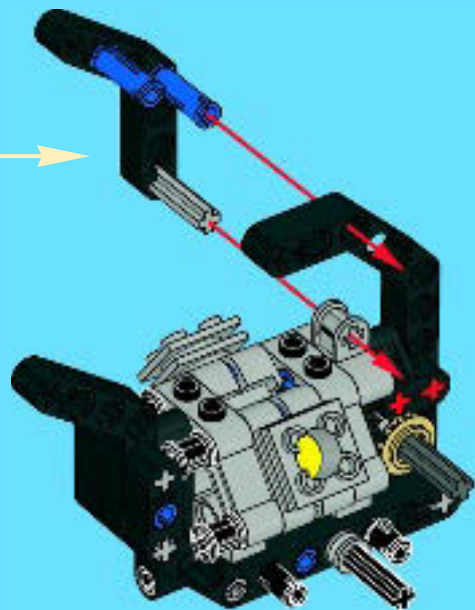
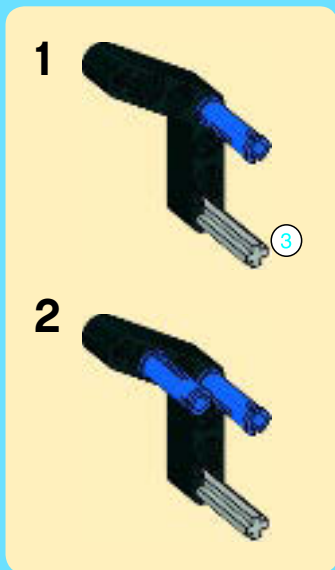

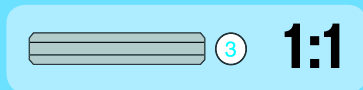

13

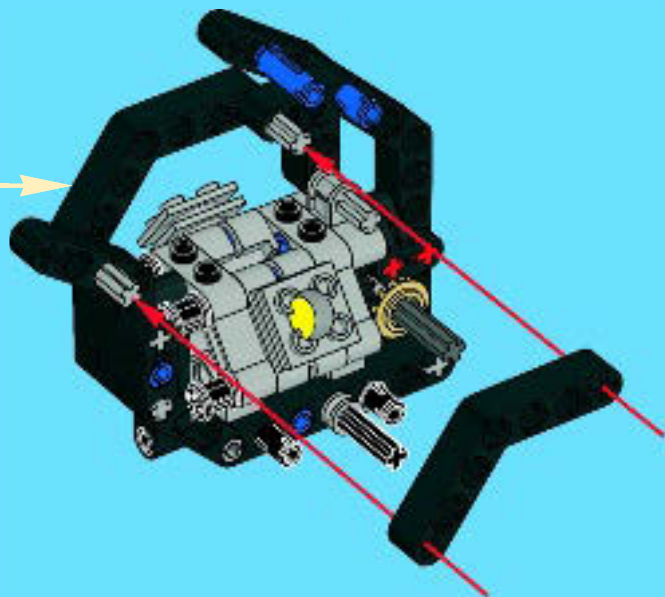
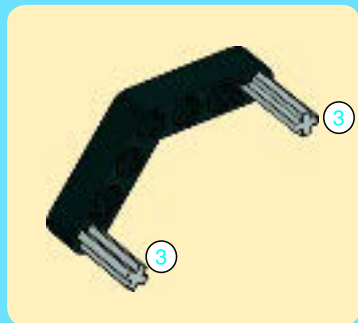



2x

14

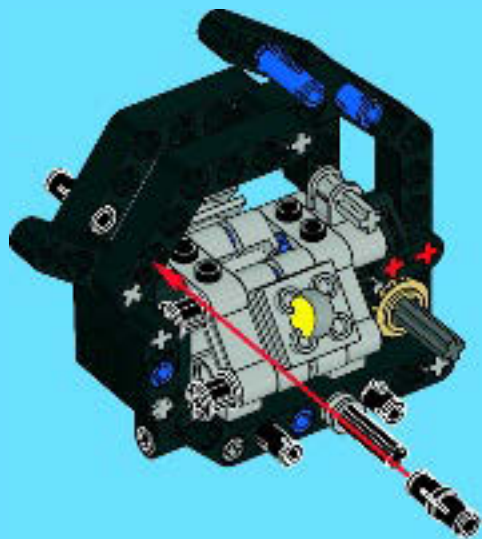

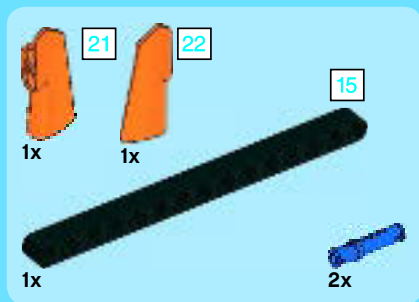

15

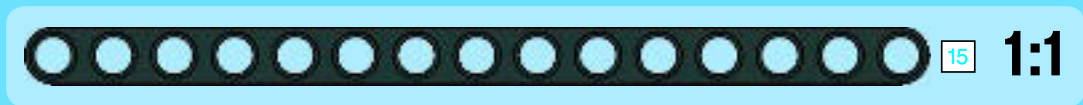
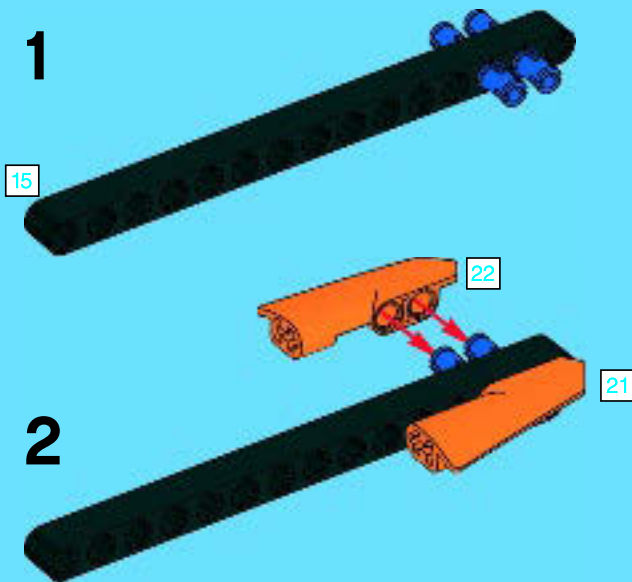

3

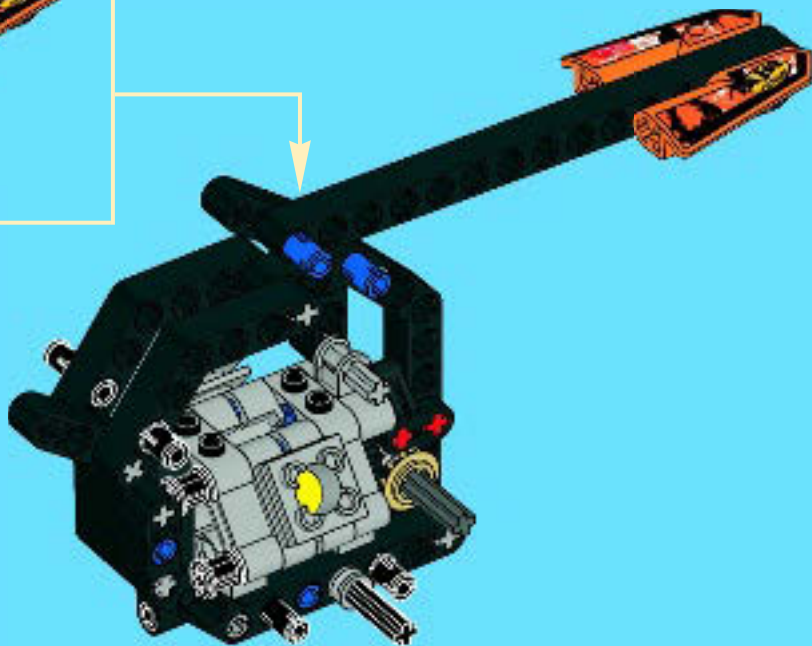
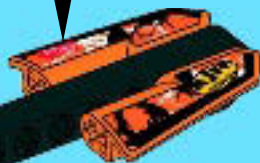

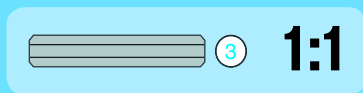
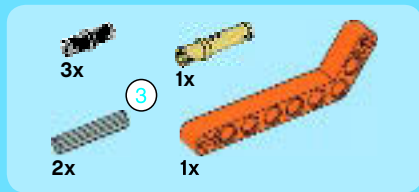

16

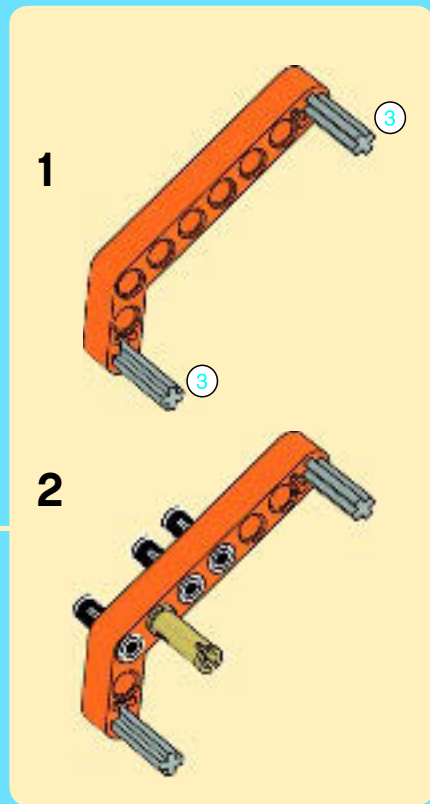
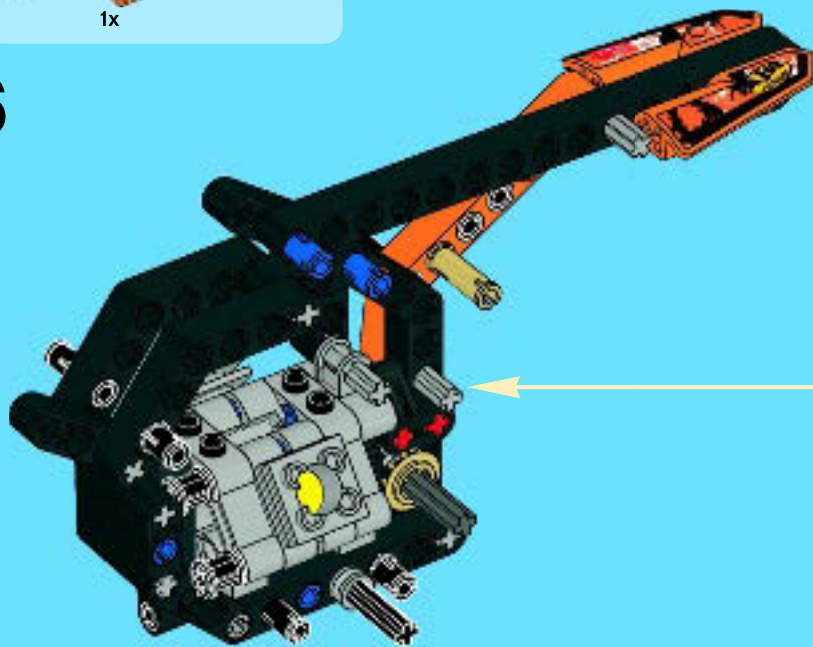



1x

17

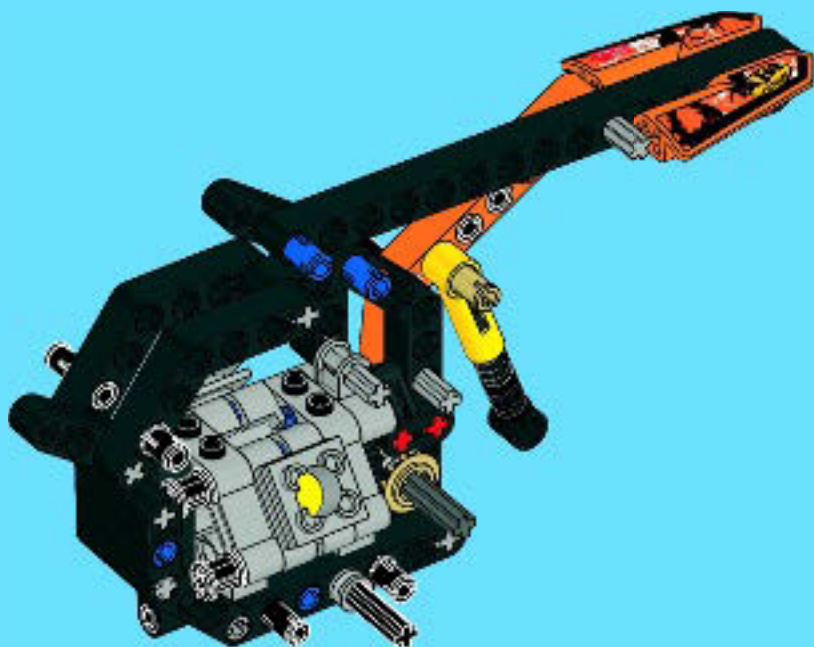



1x



1x

18

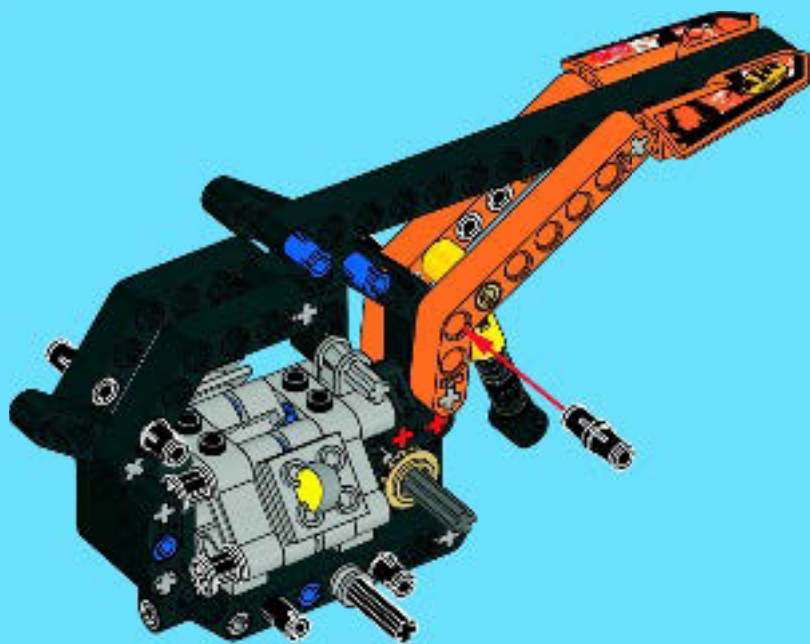

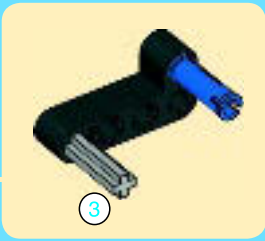
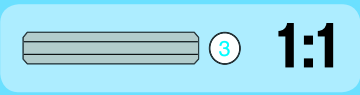

19

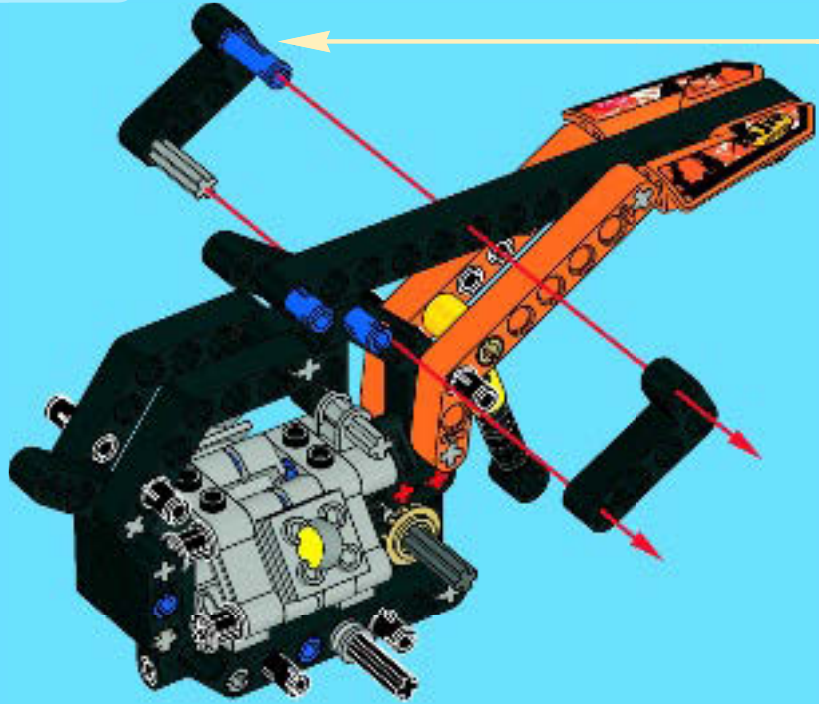



2x



2x



1x

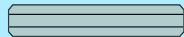

3

1:1

20

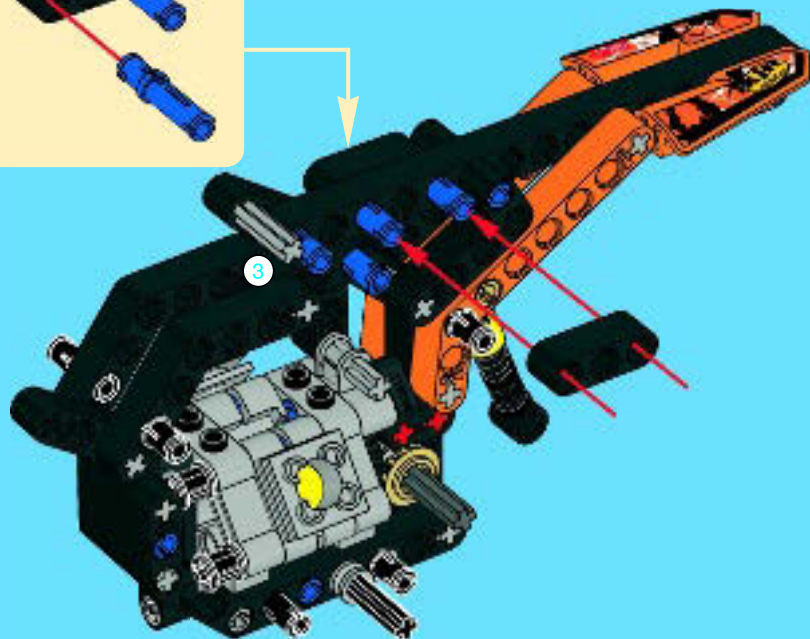
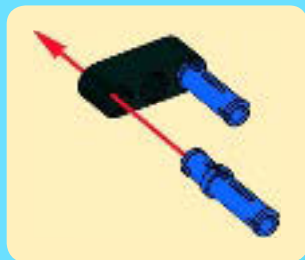

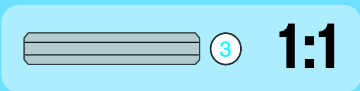

21

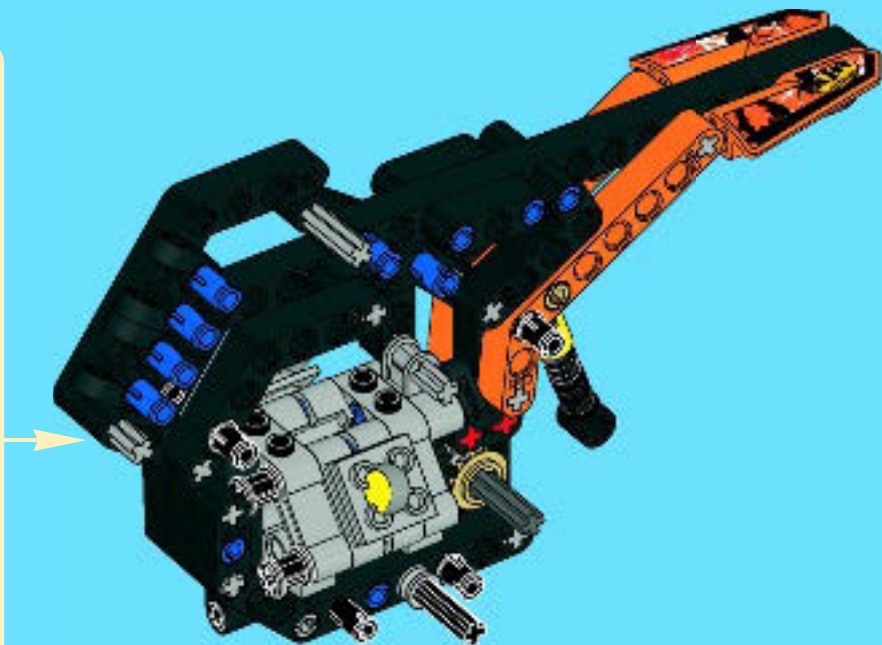
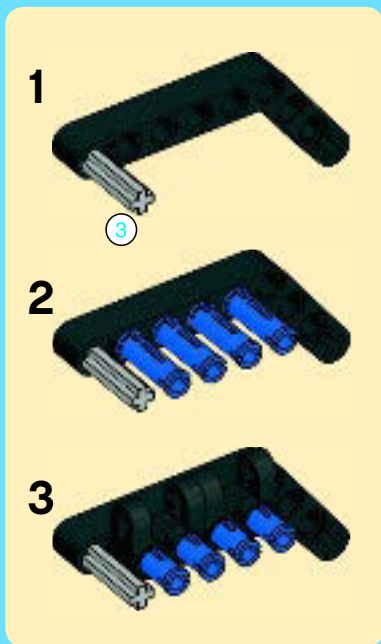

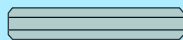
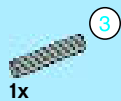

3

1:1

22

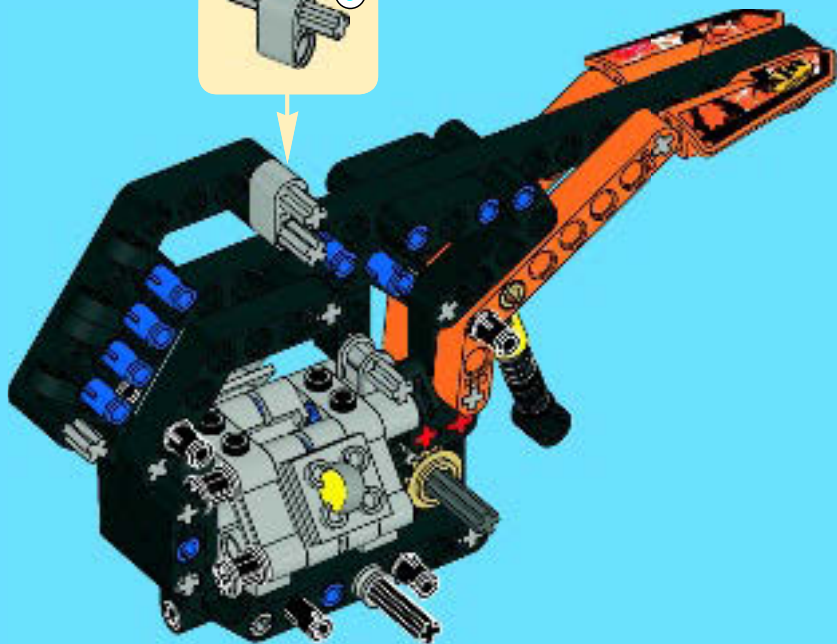
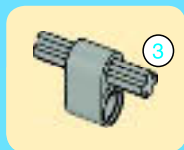



23

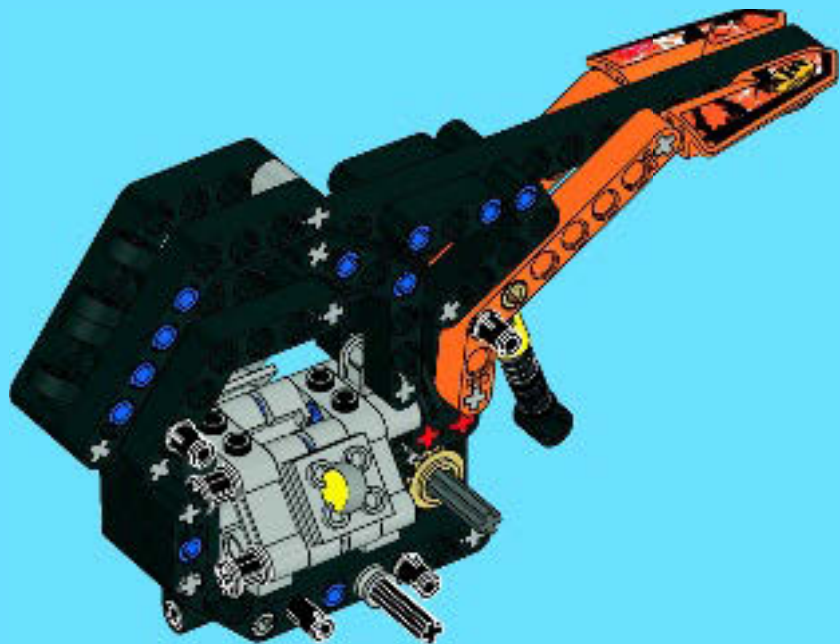



1x

24

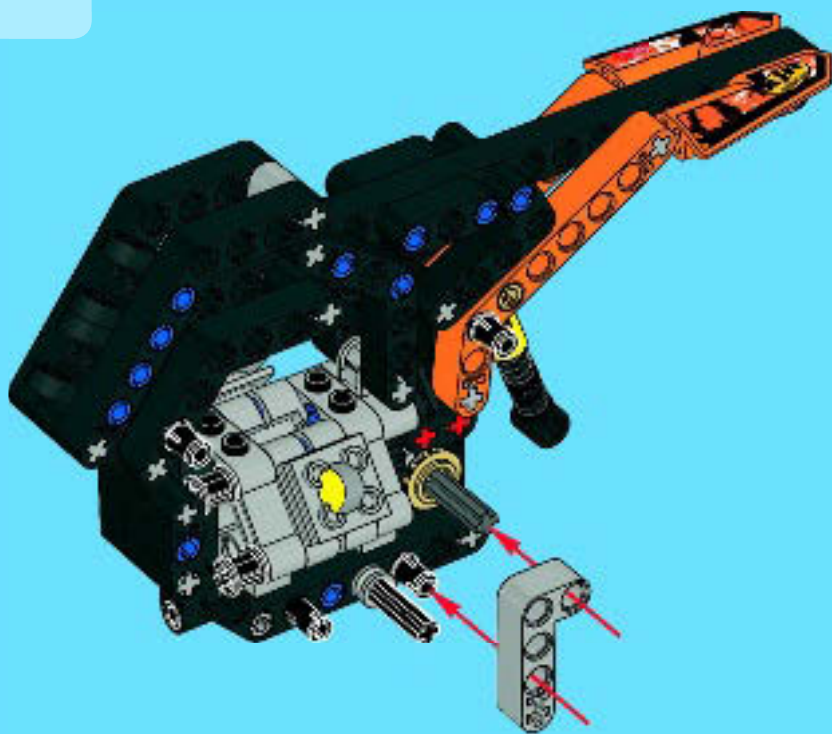

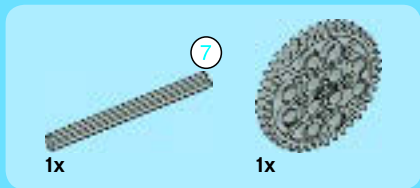
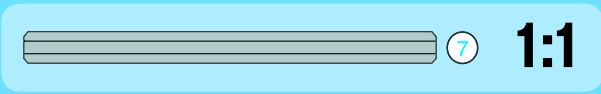

1

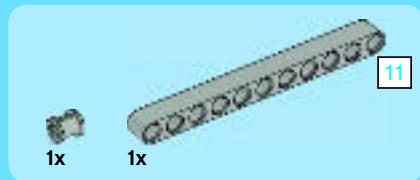

2

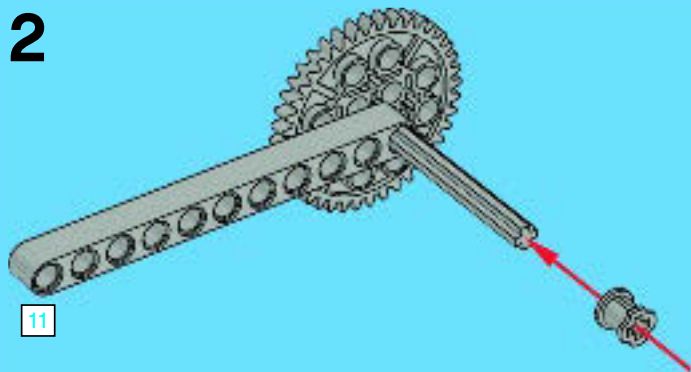

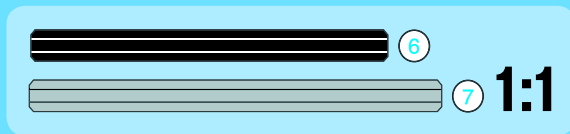
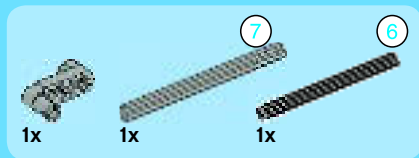

3

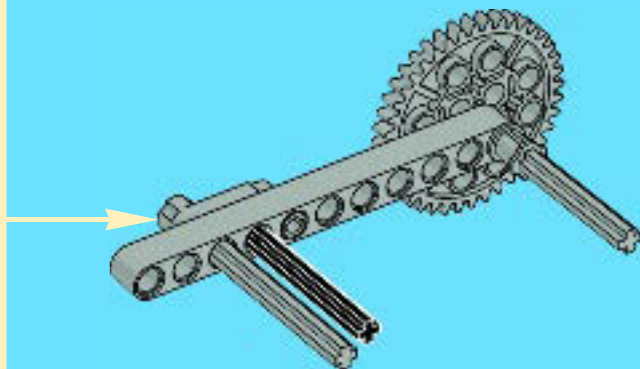
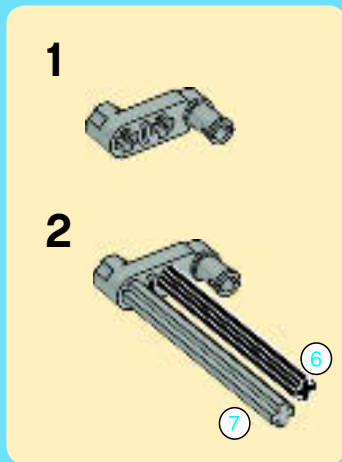



1x



1x

4

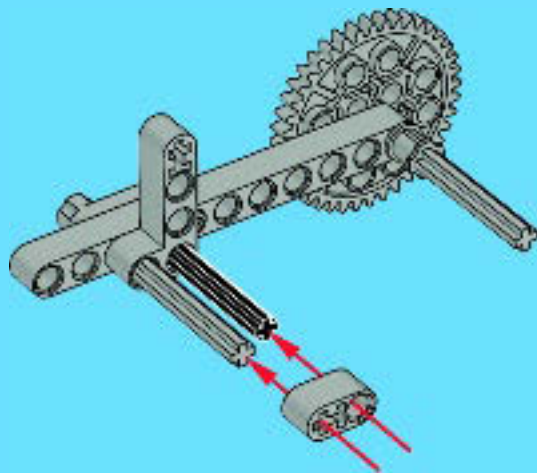

1x



1x

5

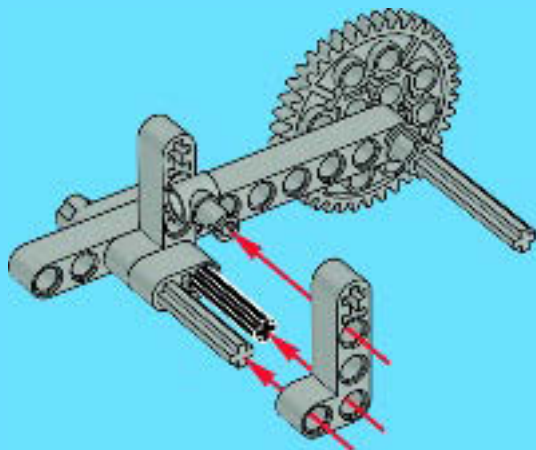



6

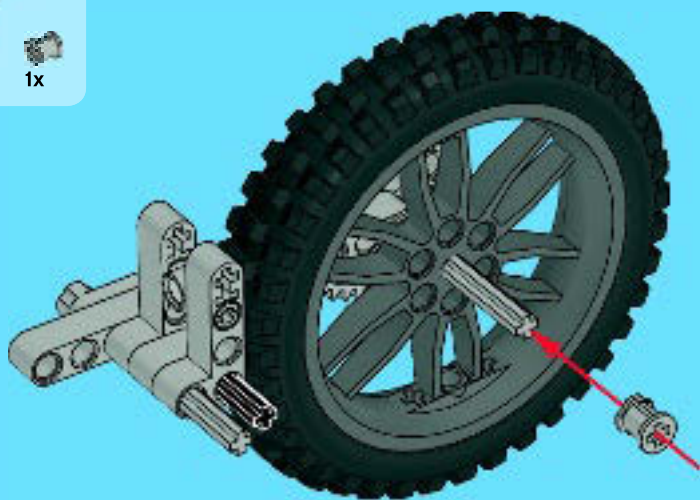

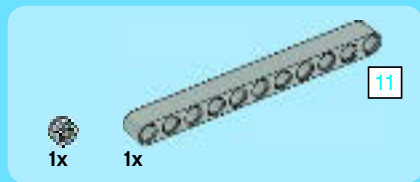

7

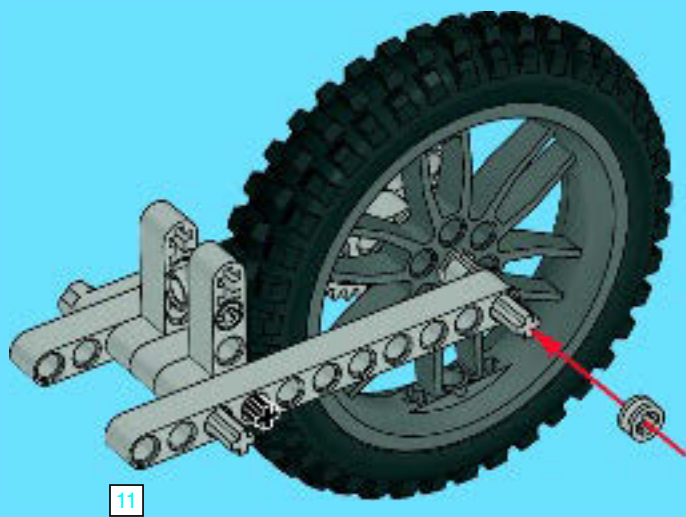



1x

8

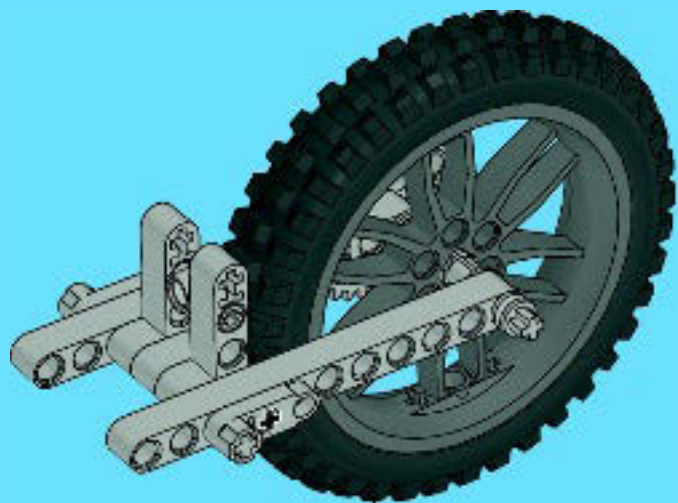

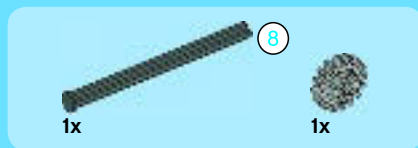

25

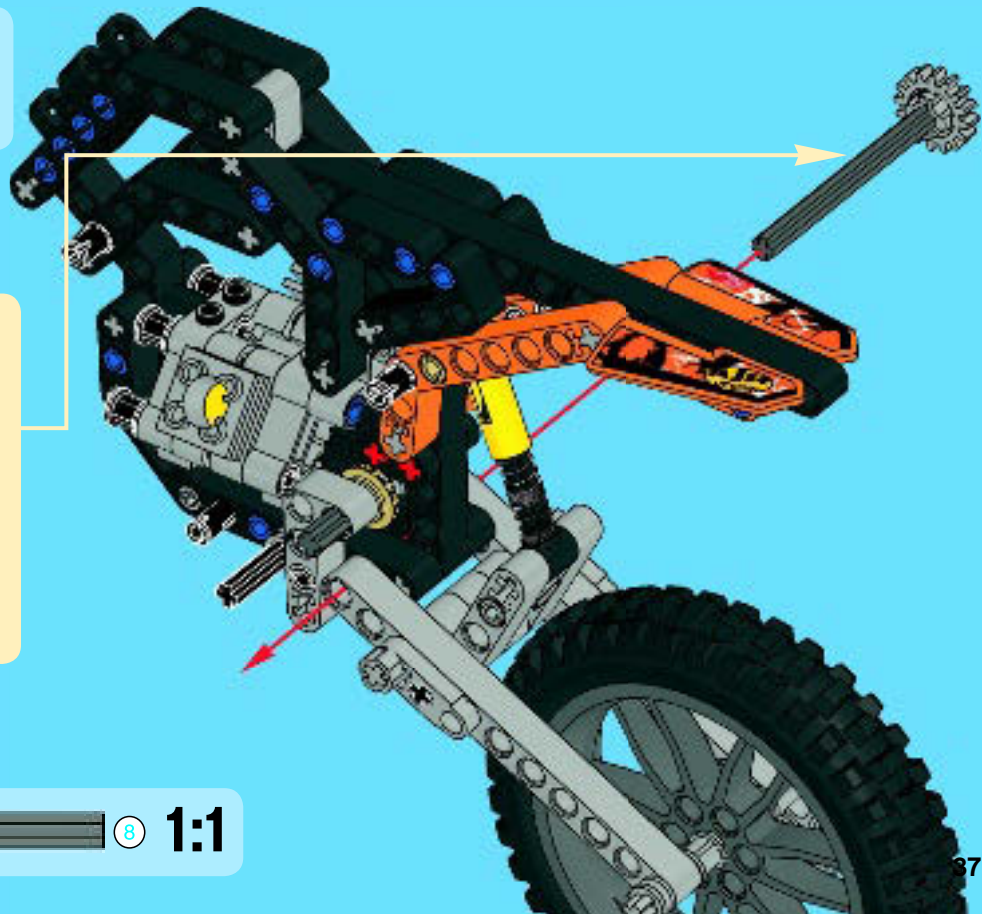
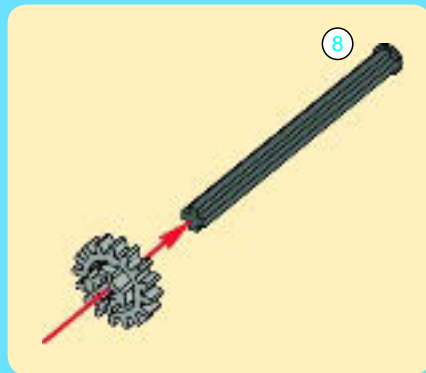



1x



2x

26



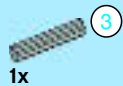

27

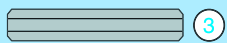
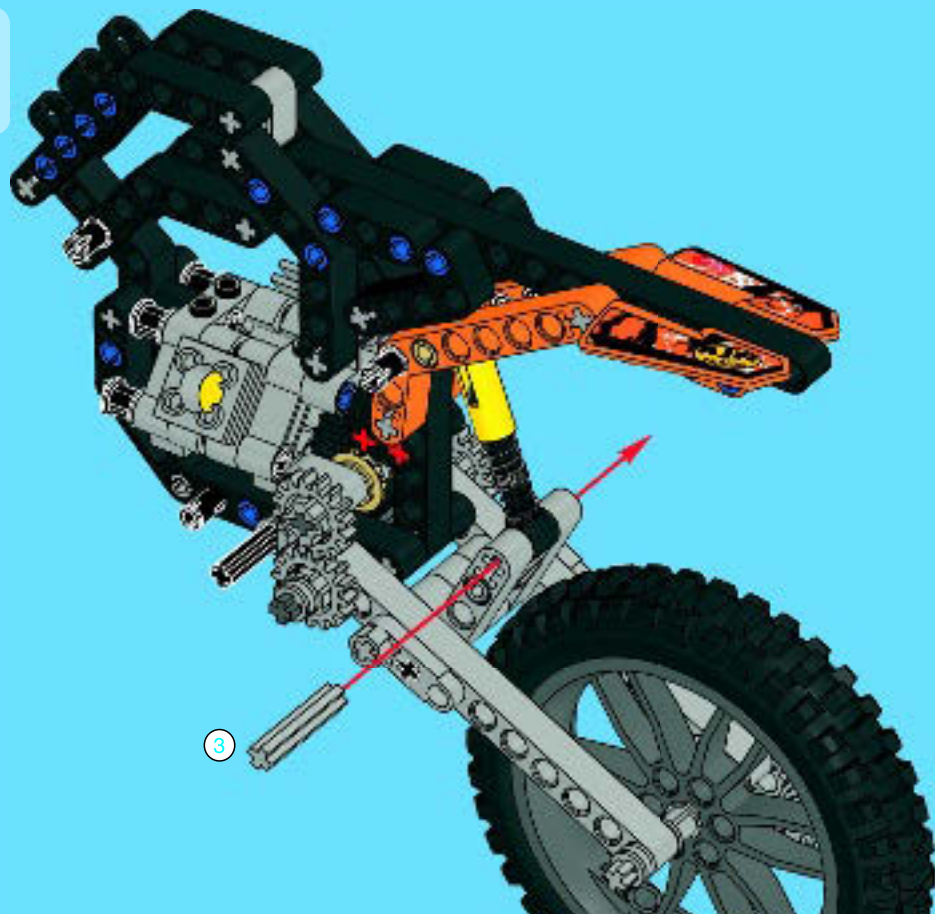

1:1

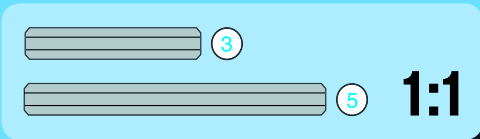
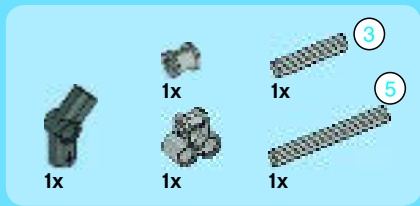

28

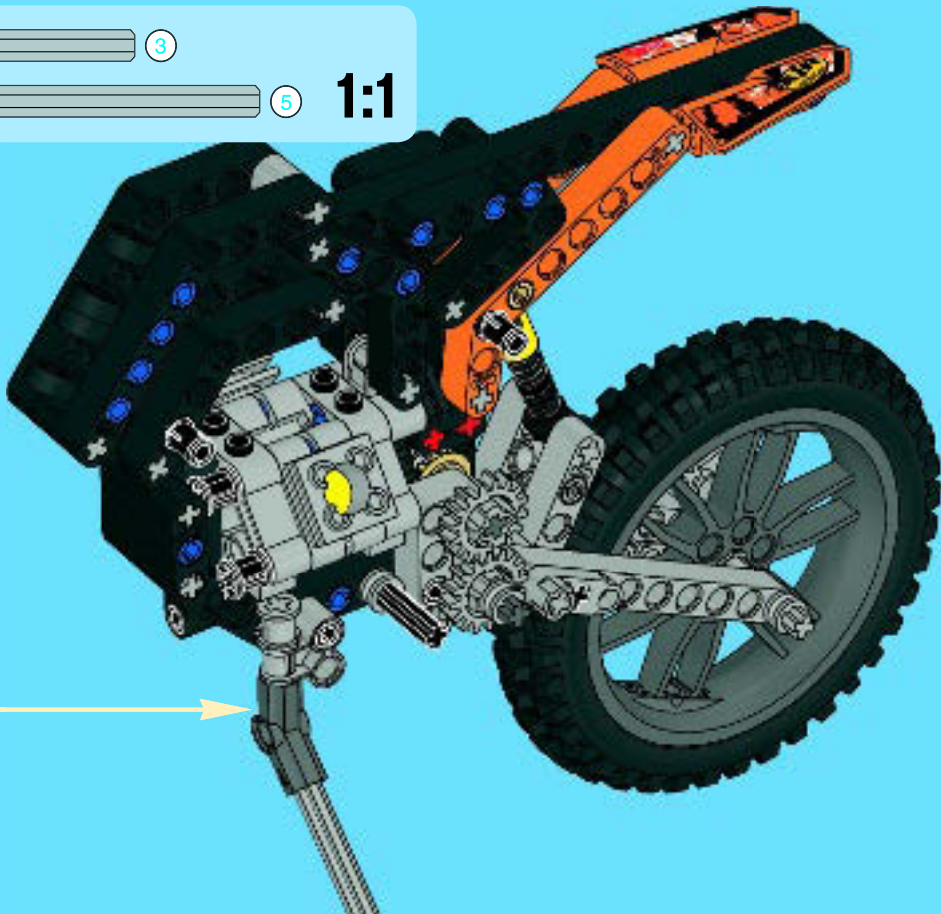
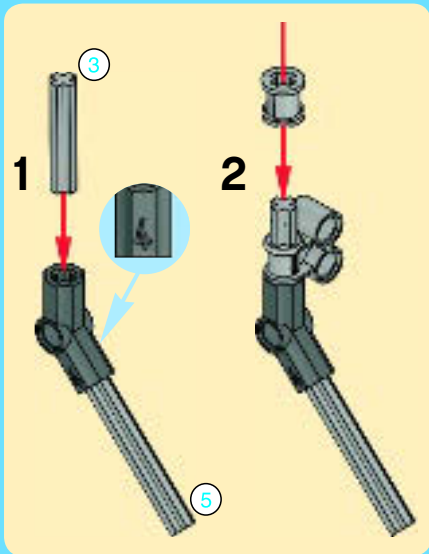



1x



1x

29

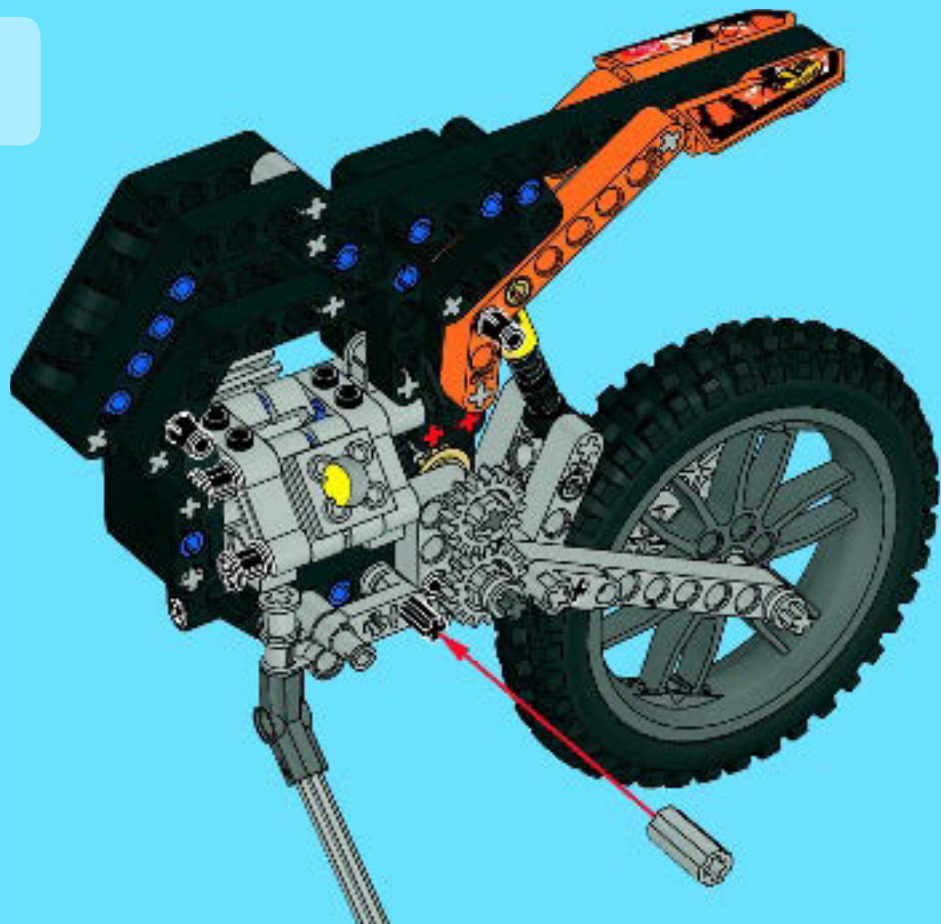



39x

30

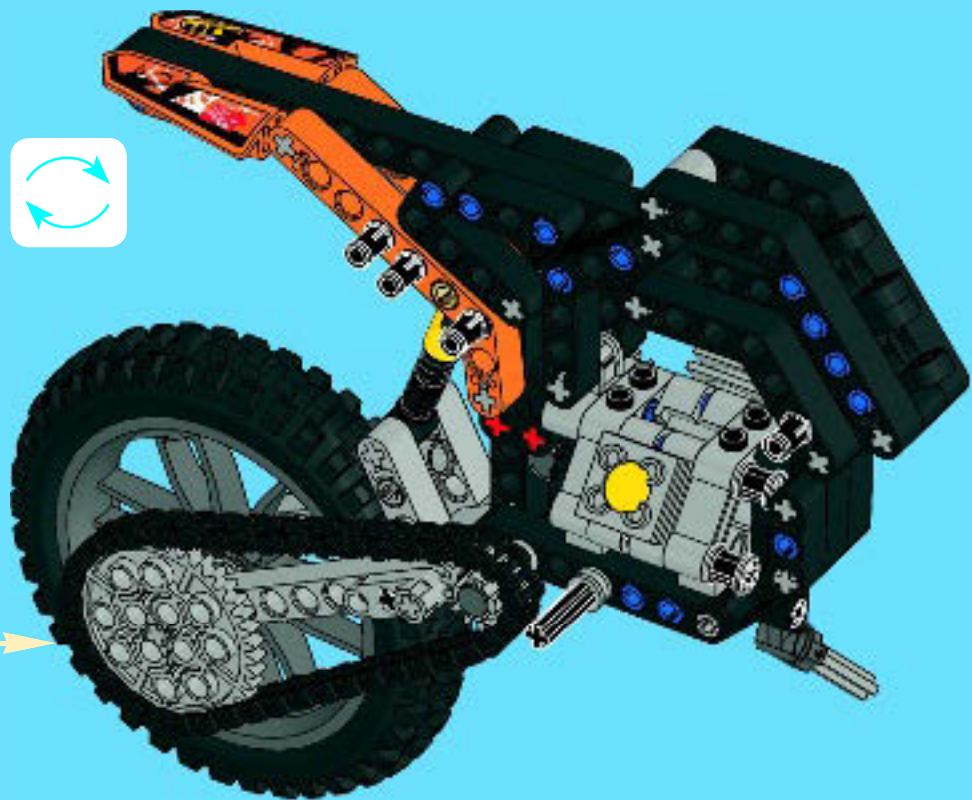

39x



1x



1x

31

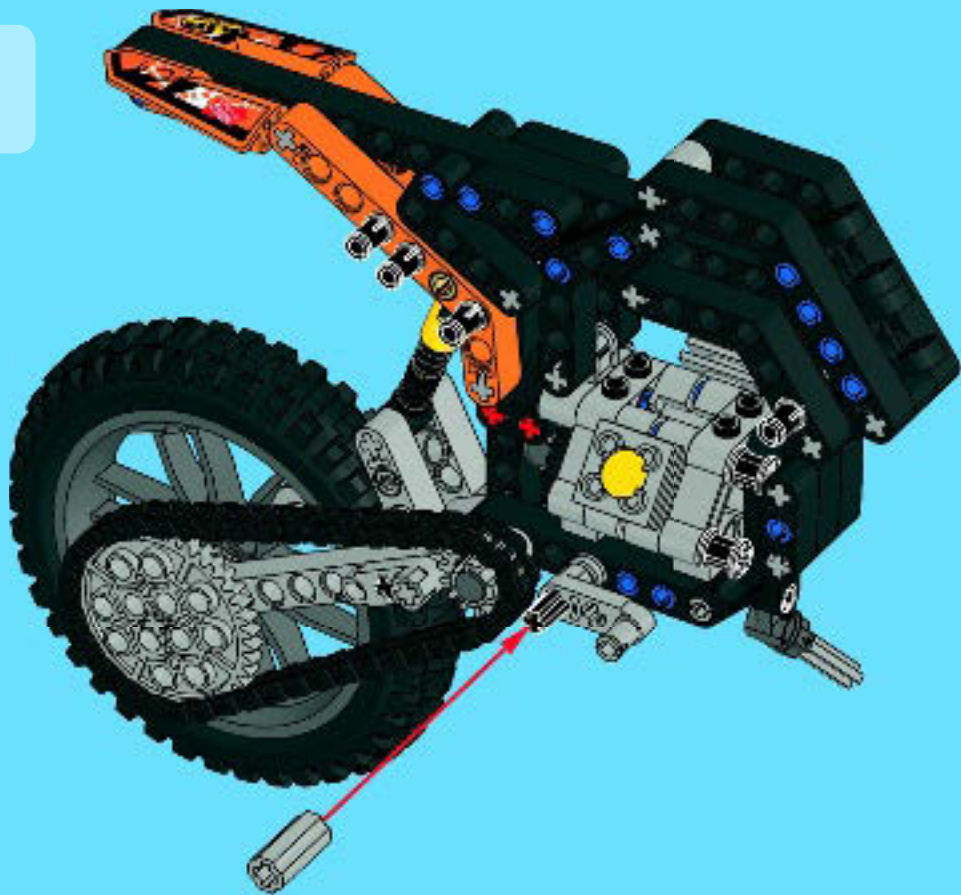

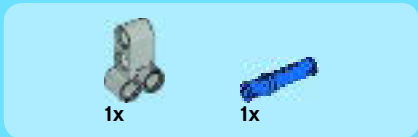
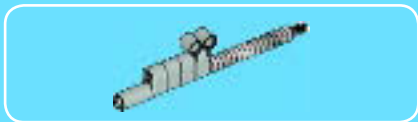

1

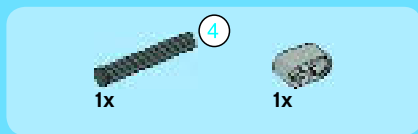
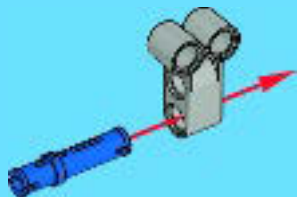

2

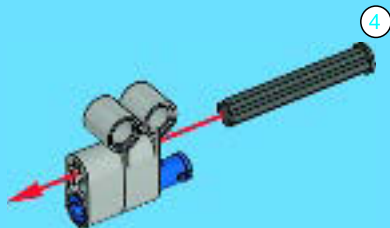



1x



1x

3

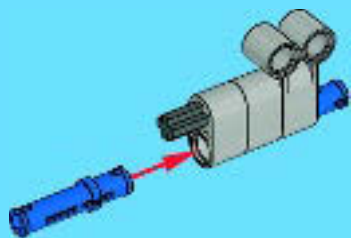

1x

4

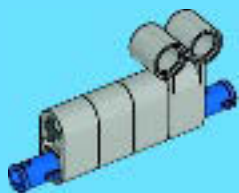

1x



1x

5

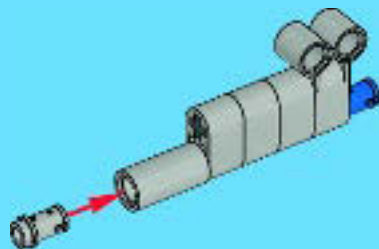

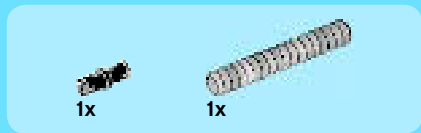

6

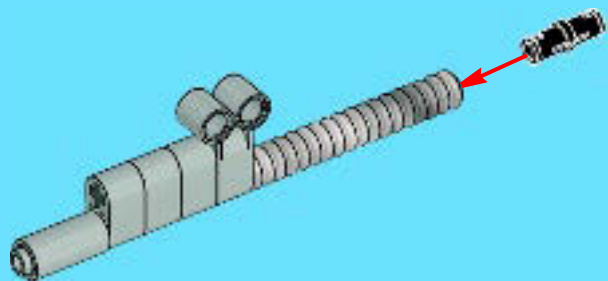

32

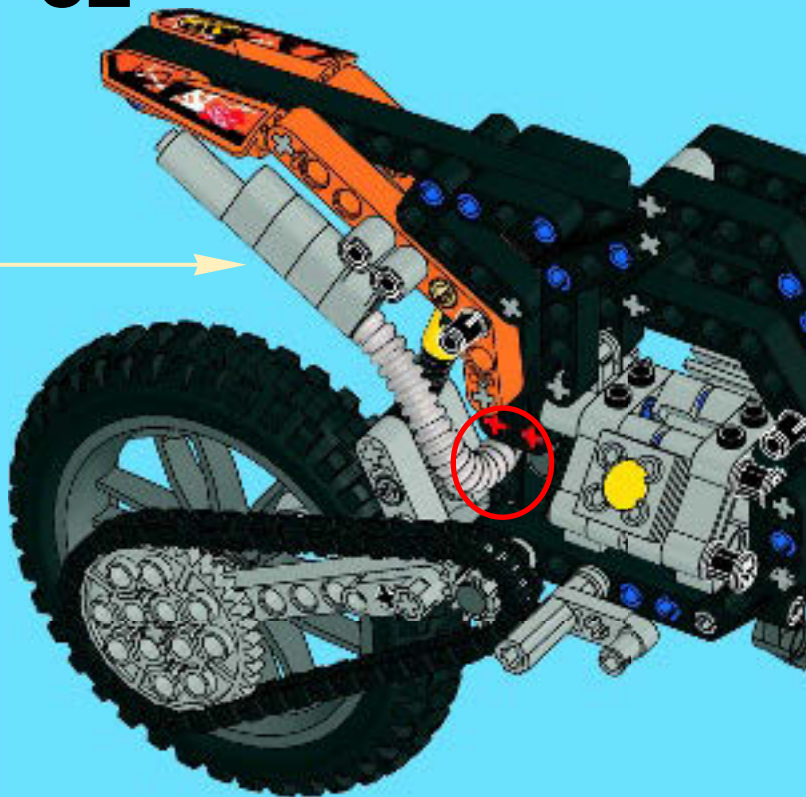



1

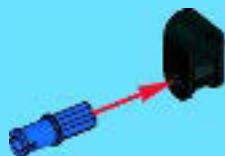

2

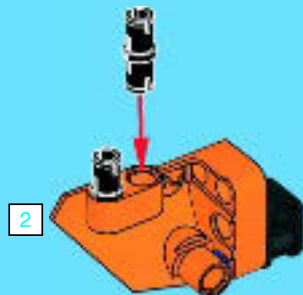

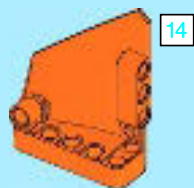

1x

3

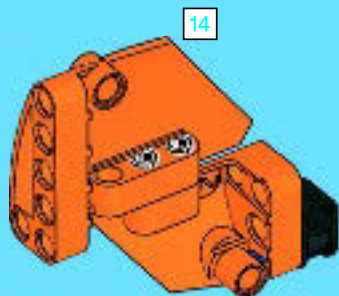

1x



1x

4

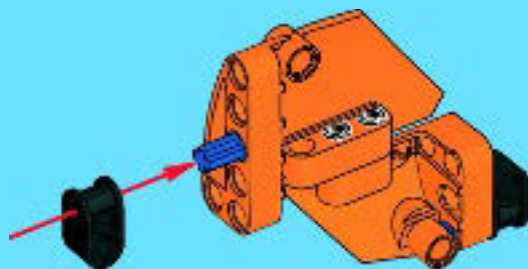



5

1

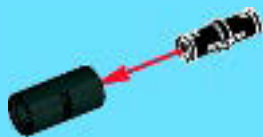

2

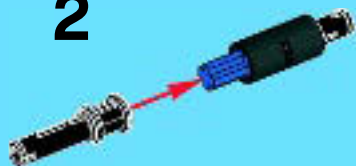

3

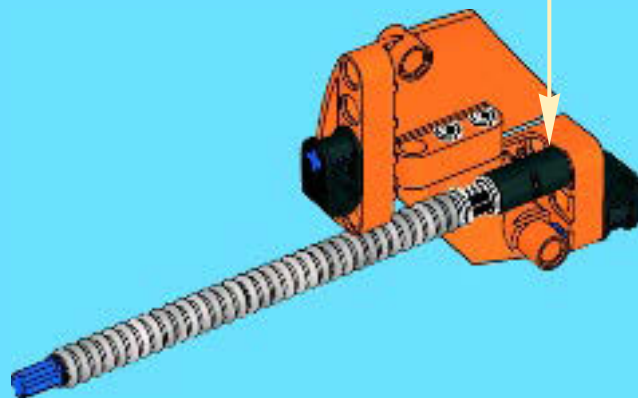



6

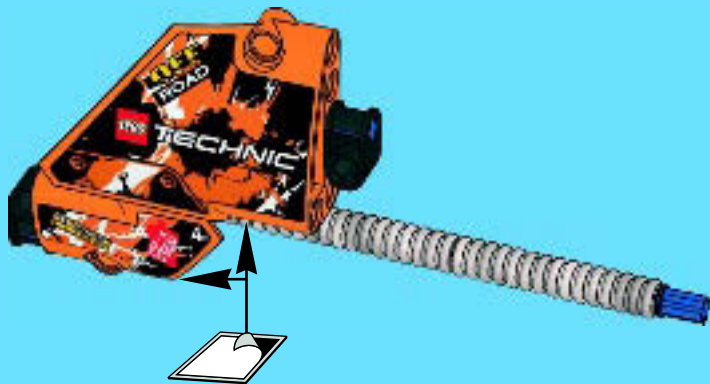

33

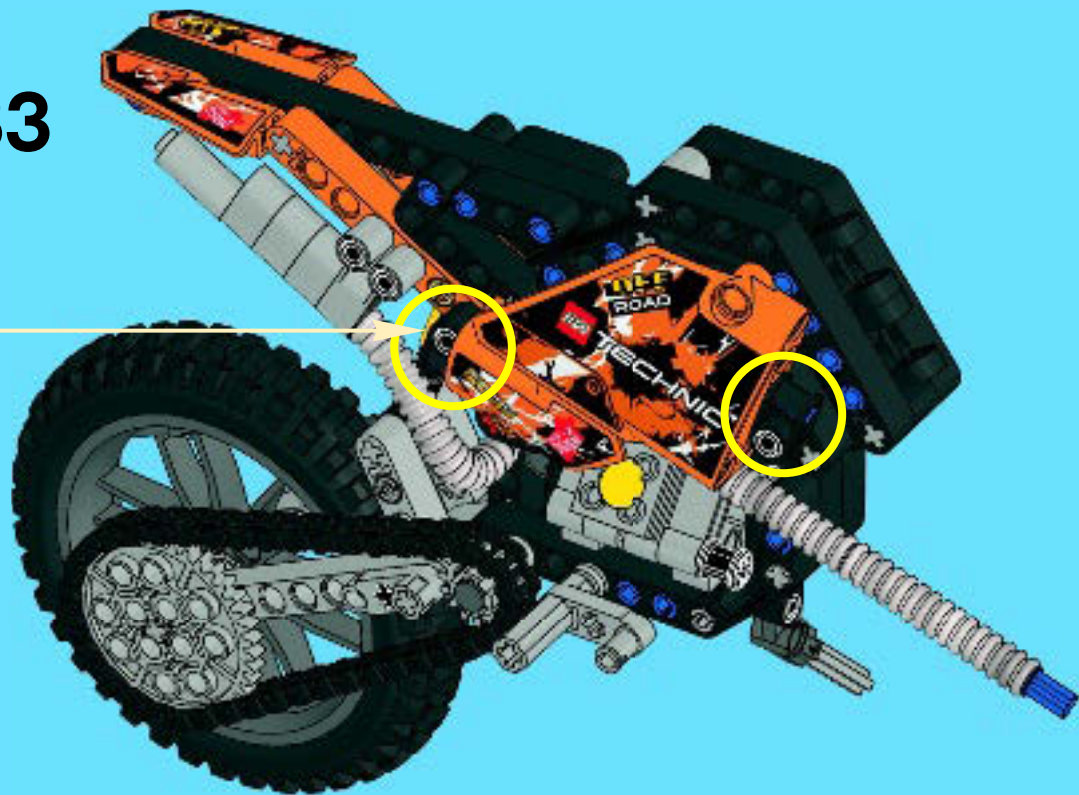



34

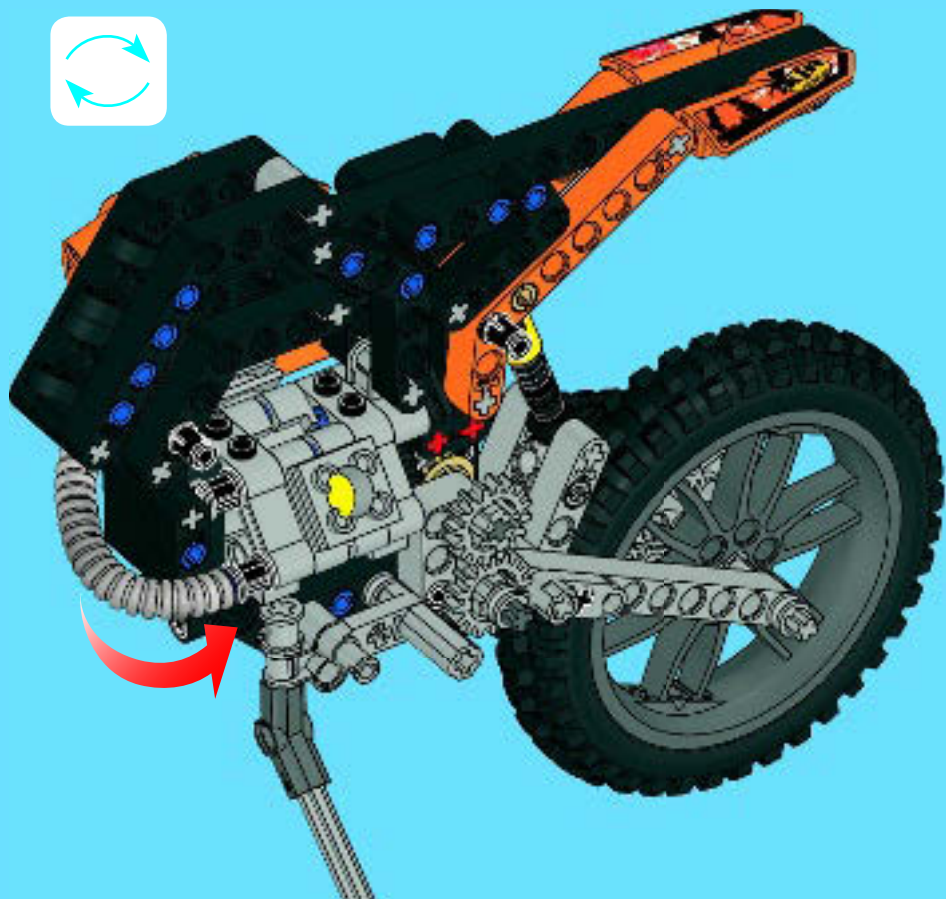



1x



1x

1

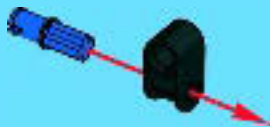

2x



1

1x

2

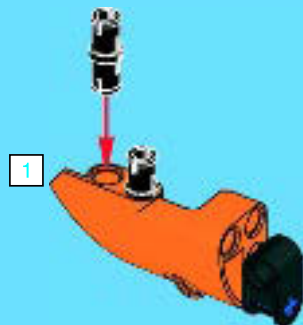



1x

3

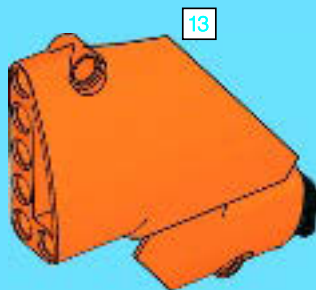

1x



1x

4

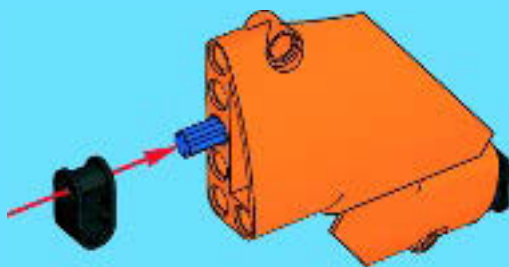

5

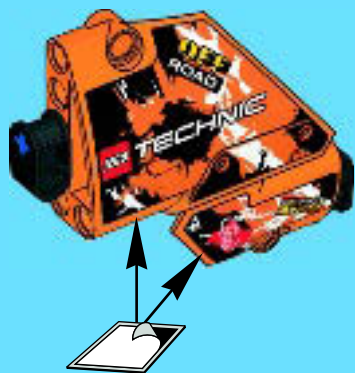

35



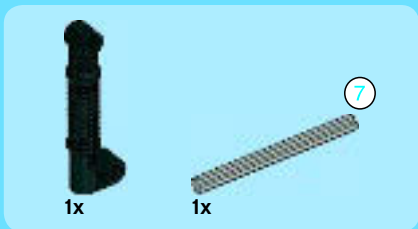
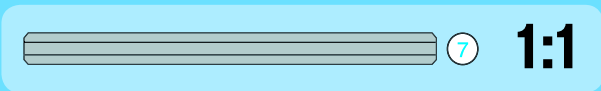

1

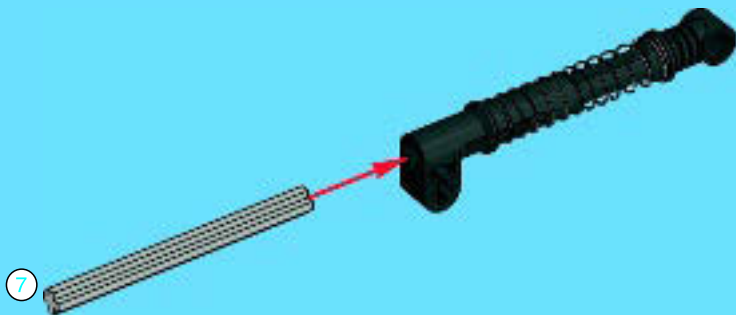



1x

2



2x

3



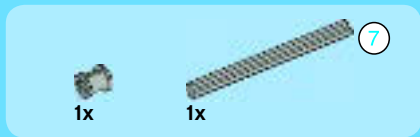

4

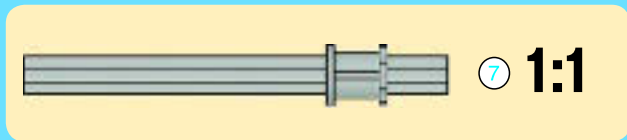

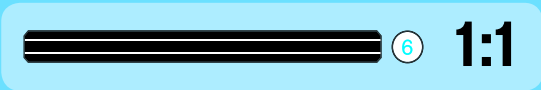
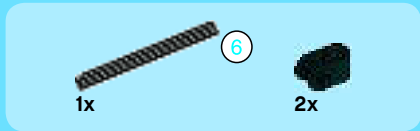

5

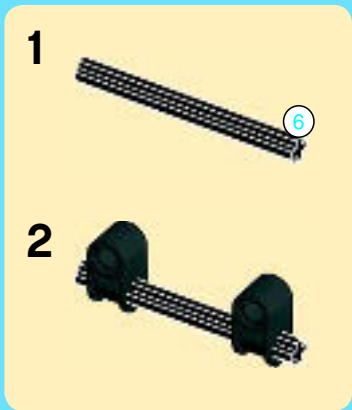



6

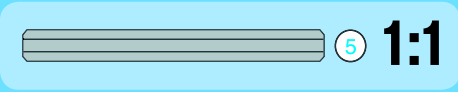
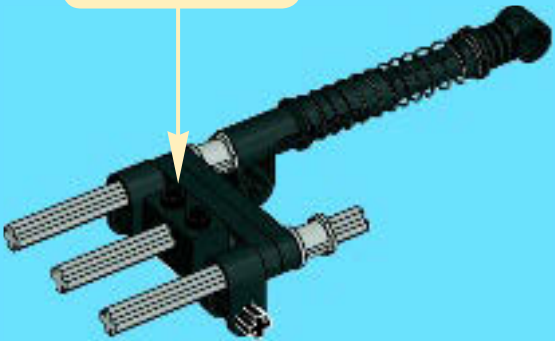
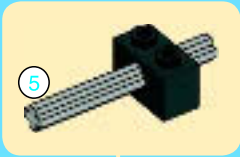

7

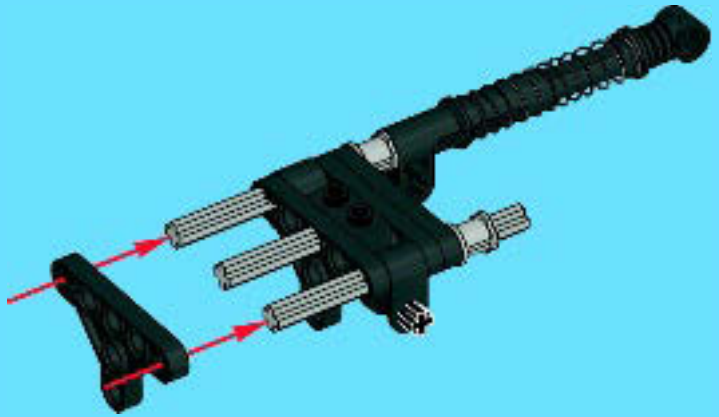



2x

8

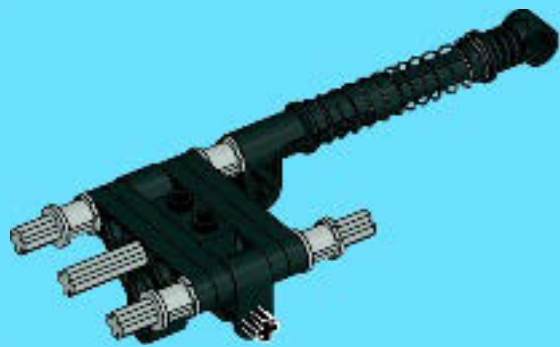

2x

9

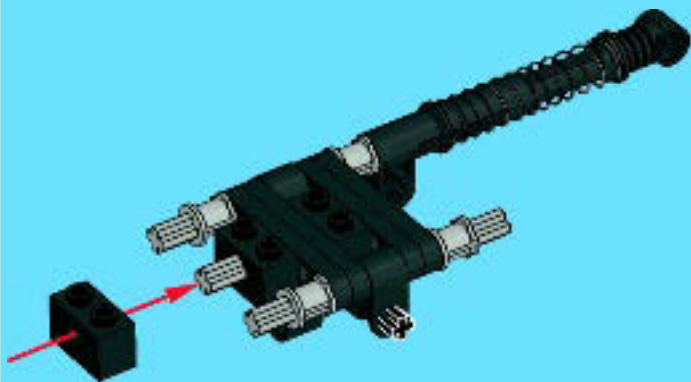

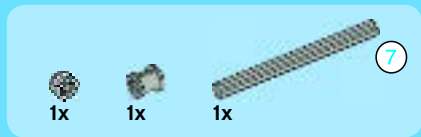

10

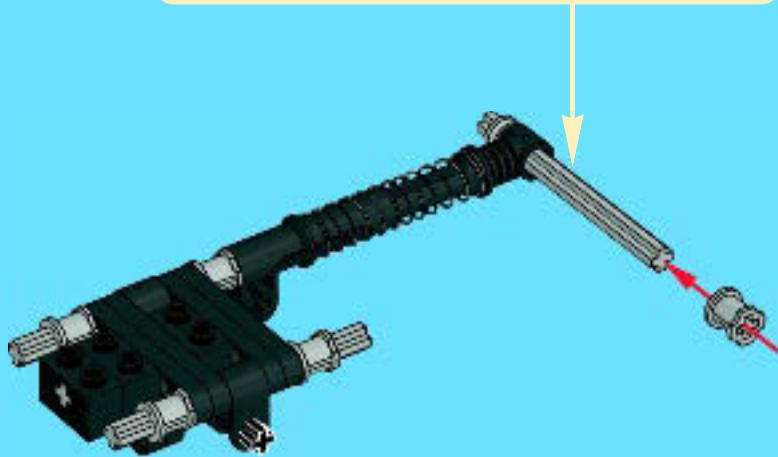
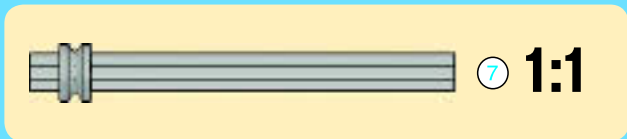



11





1x



1x

12





2x



2x

13



2x





36





1x

1



1x



1x

2



1x

3





2x

4



1x

5

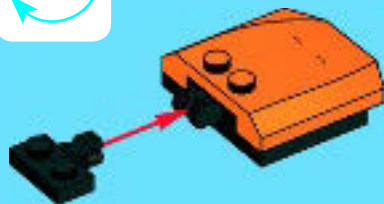



1x

6

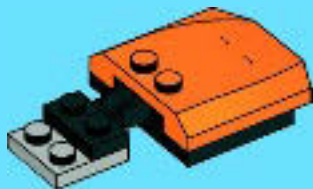

1x

7



8

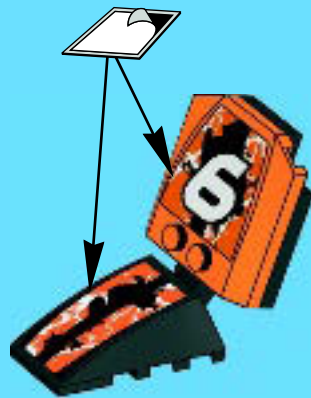

37



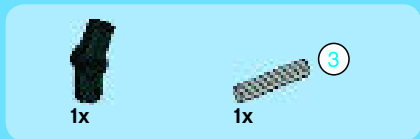
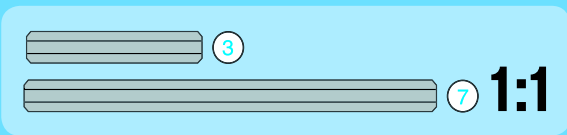

1

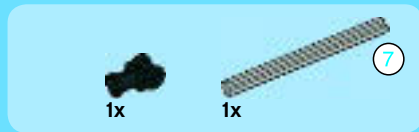

2

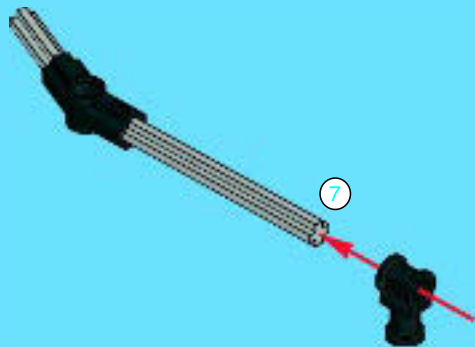



1x



1x

3



1x



1x

4

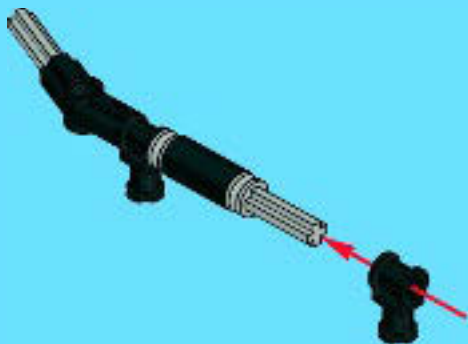



1x



1x

5



2x

6

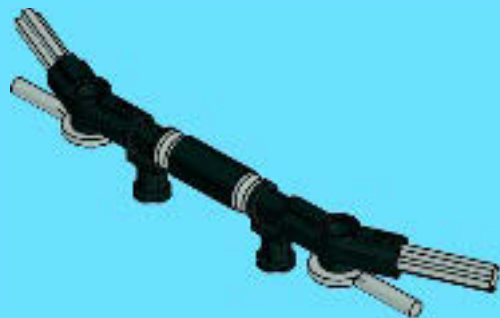

38







TECHNIC



42011



42004



42010



42002



42007



42006



42000



TECHNIC

42010



**PULL
BACK**

**RÉTRO-
FRICTION**

42011





3



www.LEGOclub.com/Max

LEGO club™

FREE*! GRATIS! GRATUIT!

*Paid subscription in Australia and New Zealand.
*Abonnement payant en Australie et Nouvelle-Zélande.

©2013 The LEGO Group.





WIN!

Go to www.LEGOsurvey.com/product to fill out a survey for a chance to win a cool LEGO® Product.

No purchase necessary.

Open to all residents where not prohibited.



www.LEGOsurvey.com/product

GEWINNE!

Nimm an der Umfrage auf www.LEGOsurvey.com/product teil und hab die Chance ein cooles LEGO® Produkt zu gewinnen!

Die Teilnahme am Gewinnspiel führt zu keinerlei Kaufverpflichtungen. Teilnahme in allen nicht ausgeschlossenen Ländern möglich.

WIN!

Ga naar www.LEGOsurvey.com/product, vul een enquêteformulier in en maak kans op een cool LEGO® product.

Geen aankoopverplichting. Iedereen mag deelnemen, uitgezonderd ingezetenden van landen waar een enquêteverbod geldt.

GAGNE!

Visite www.LEGOsurvey.com/product pour répondre à un questionnaire et avoir une chance de gagner un produit LEGO® très cool!

Aucune obligation d'achat. Ouvert à tous les résidents des pays autorisés.

当てよう!

www.LEGOsurvey.com/product にアクセスして、アンケートにご記入ください。当選者にはレゴ®製品を差し上げます。

お買い上げの必要はありません。禁止されていない限り、すべての皆様にご利用いただけます。



LEGO.com

6042851 / 6042853

LEGO and the LEGO logo are trademarks of the/son des marques de commerce de/son marcas registradas de LEGO Group. ©2013 The LEGO Group.