

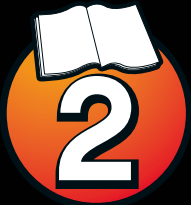

# TECHNIC

42025

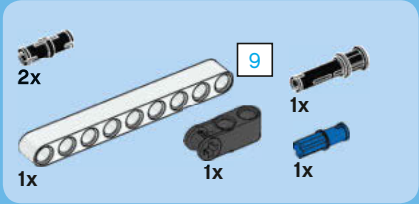

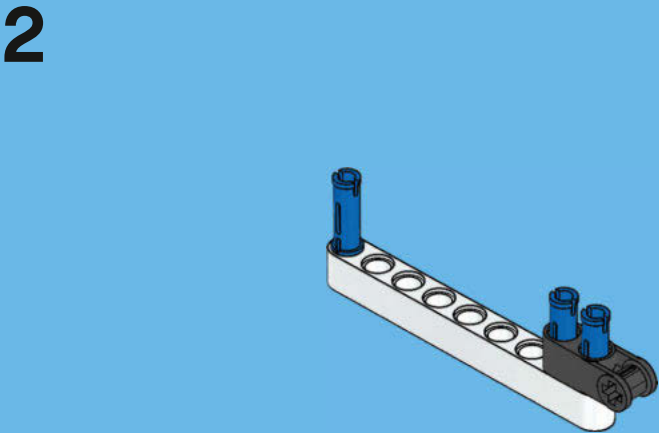
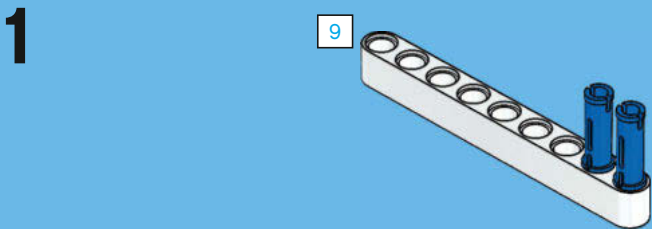
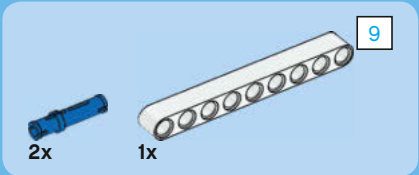
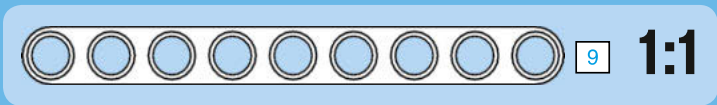
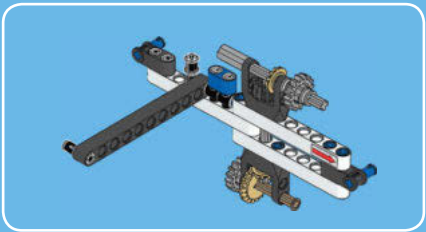

3

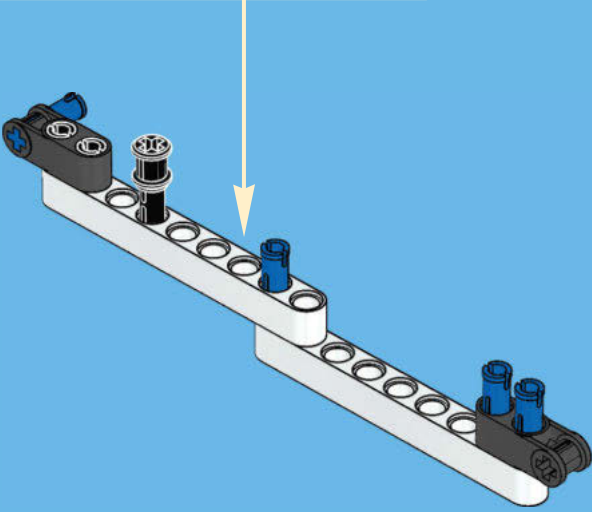
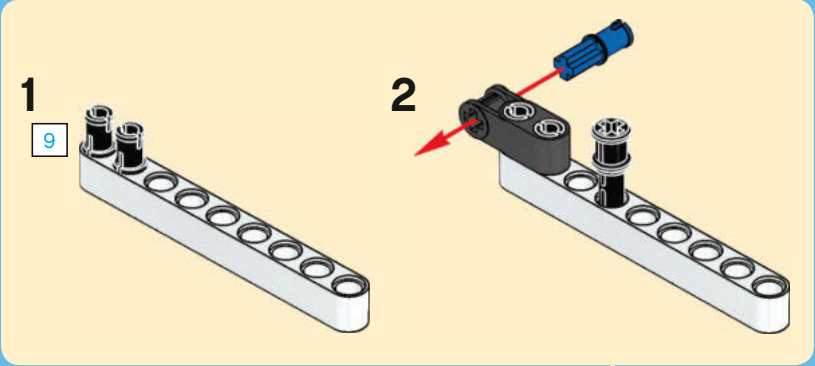

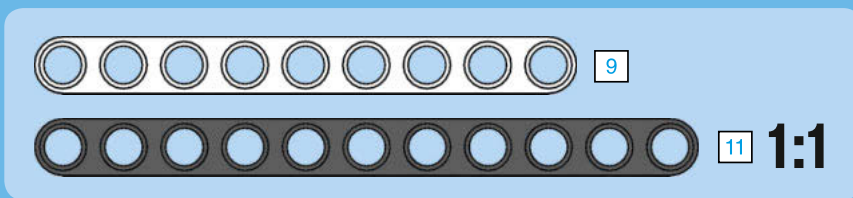
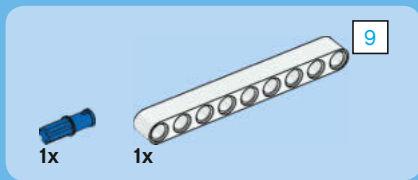

4

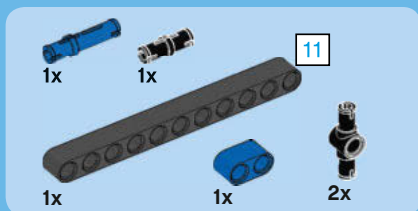
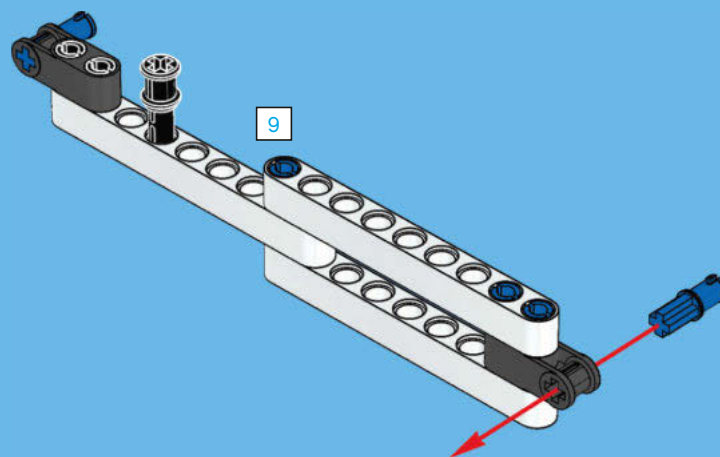

5

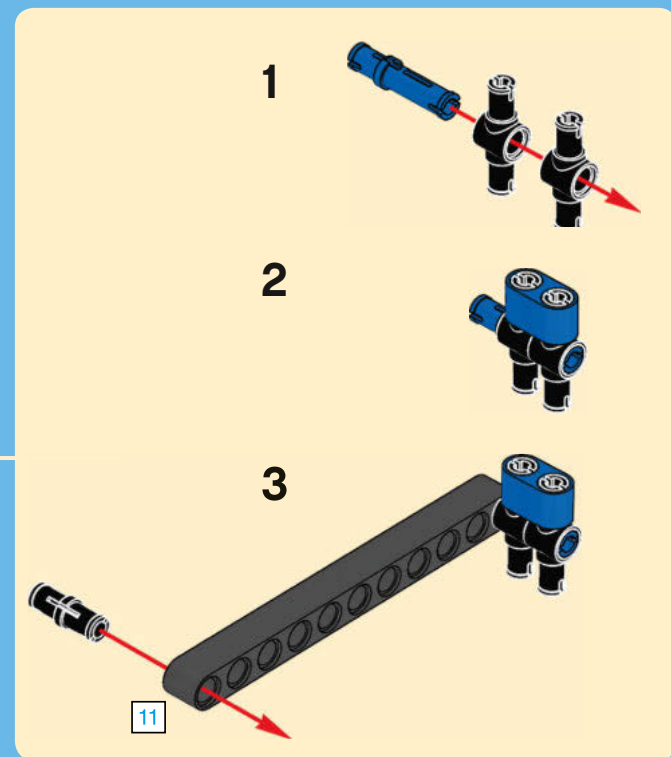
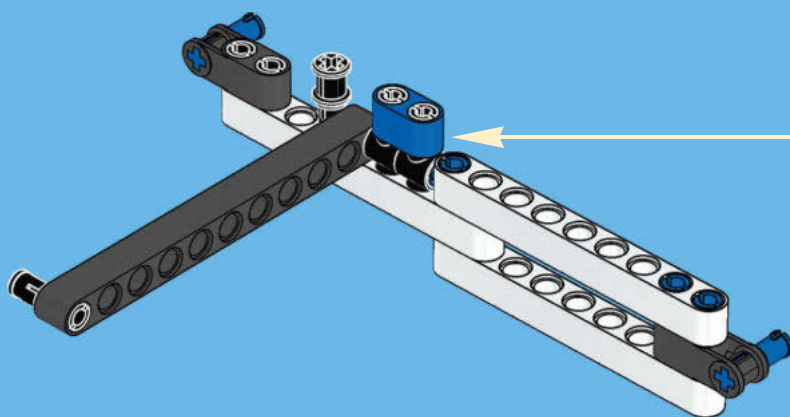

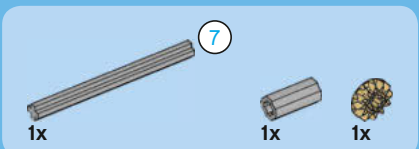
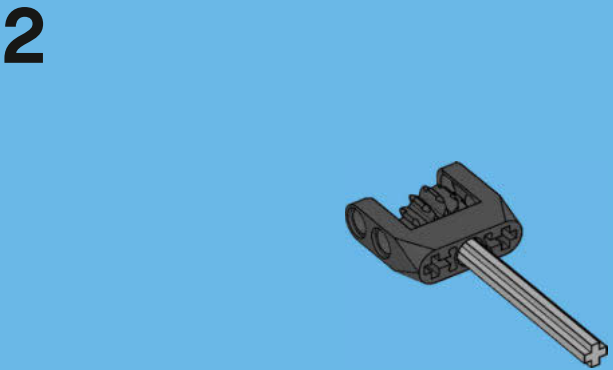
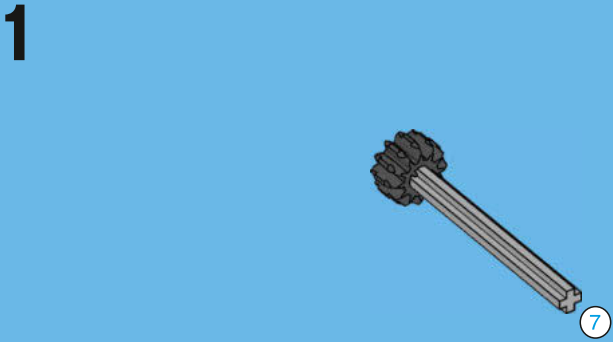
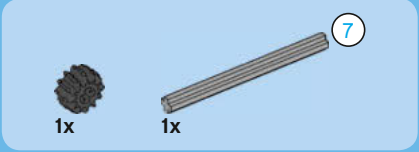

**3**

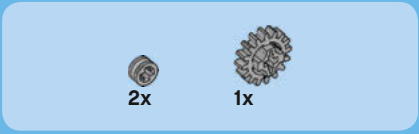
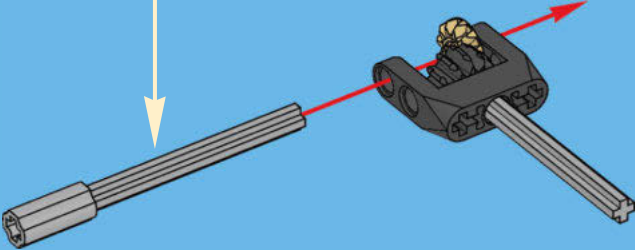
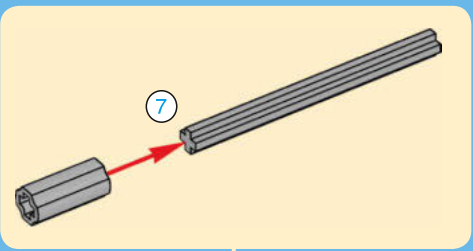

**4**

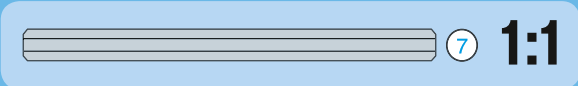
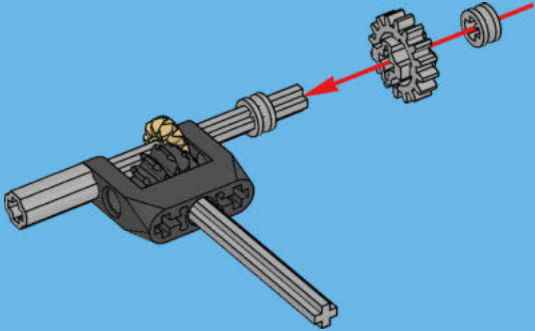

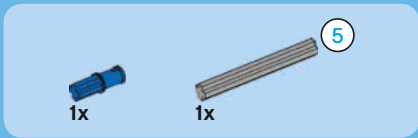

5

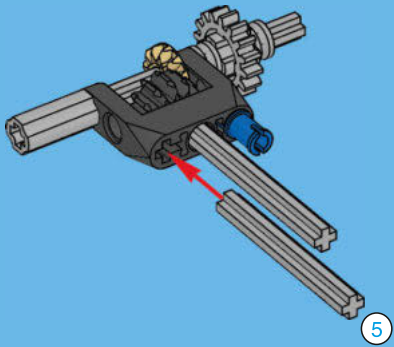

6

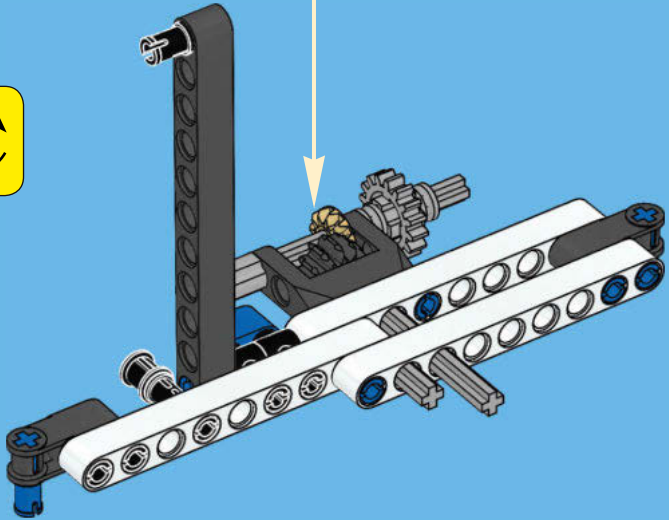

7

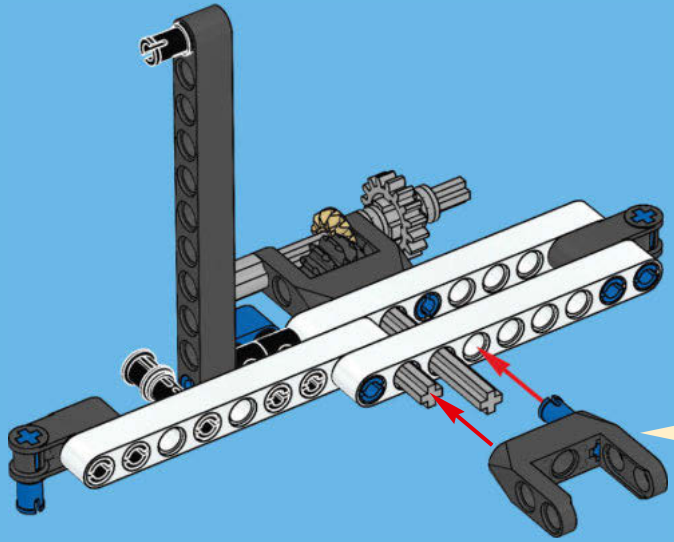
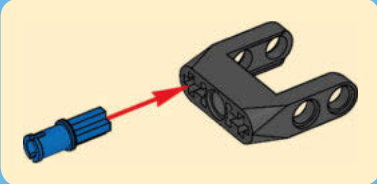



1x

8

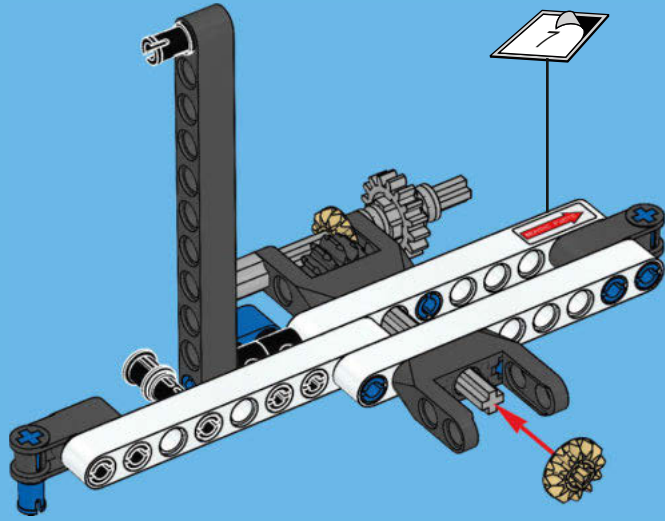

1x



1x

5



5

1:1

9

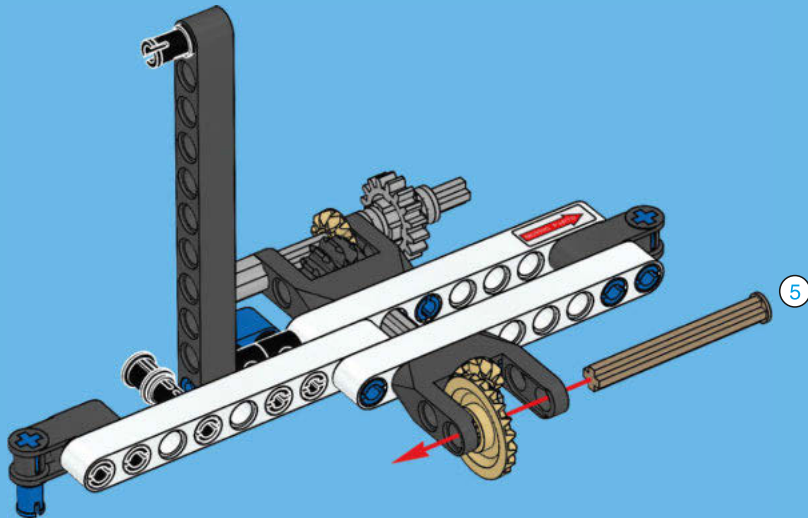

5



1x

10

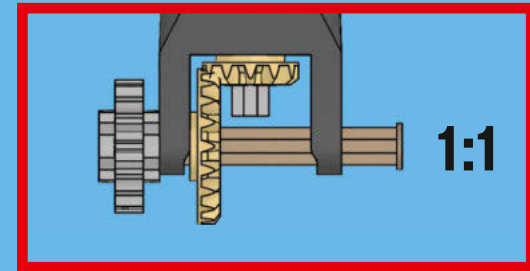
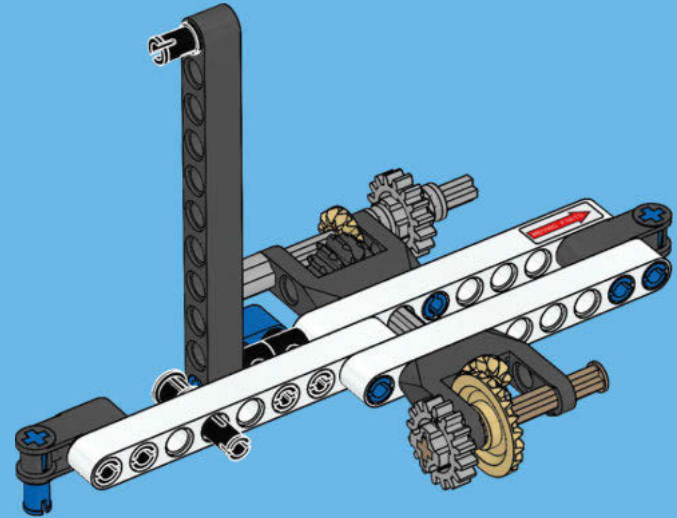

1:1

# 41

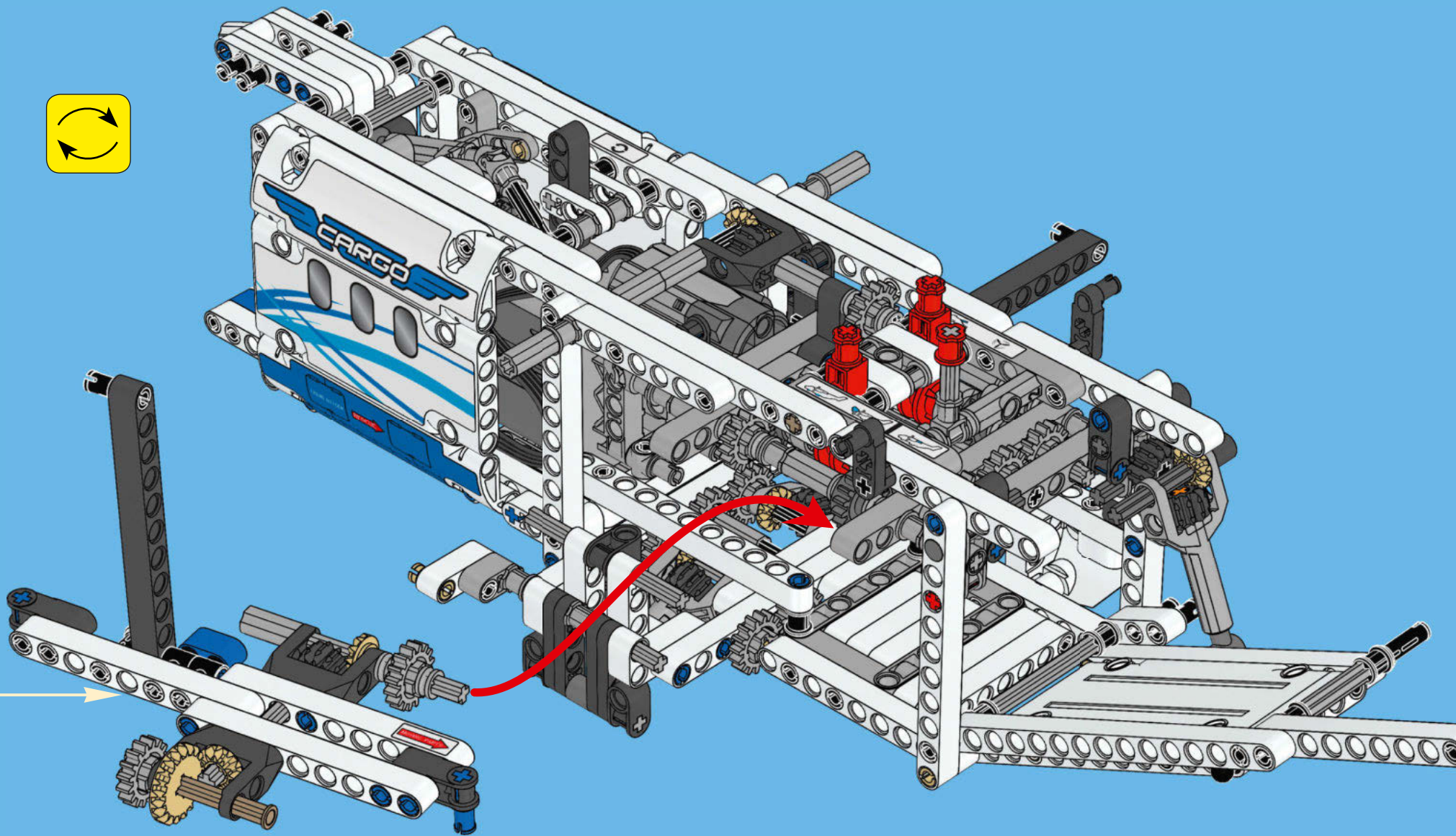



1x

42

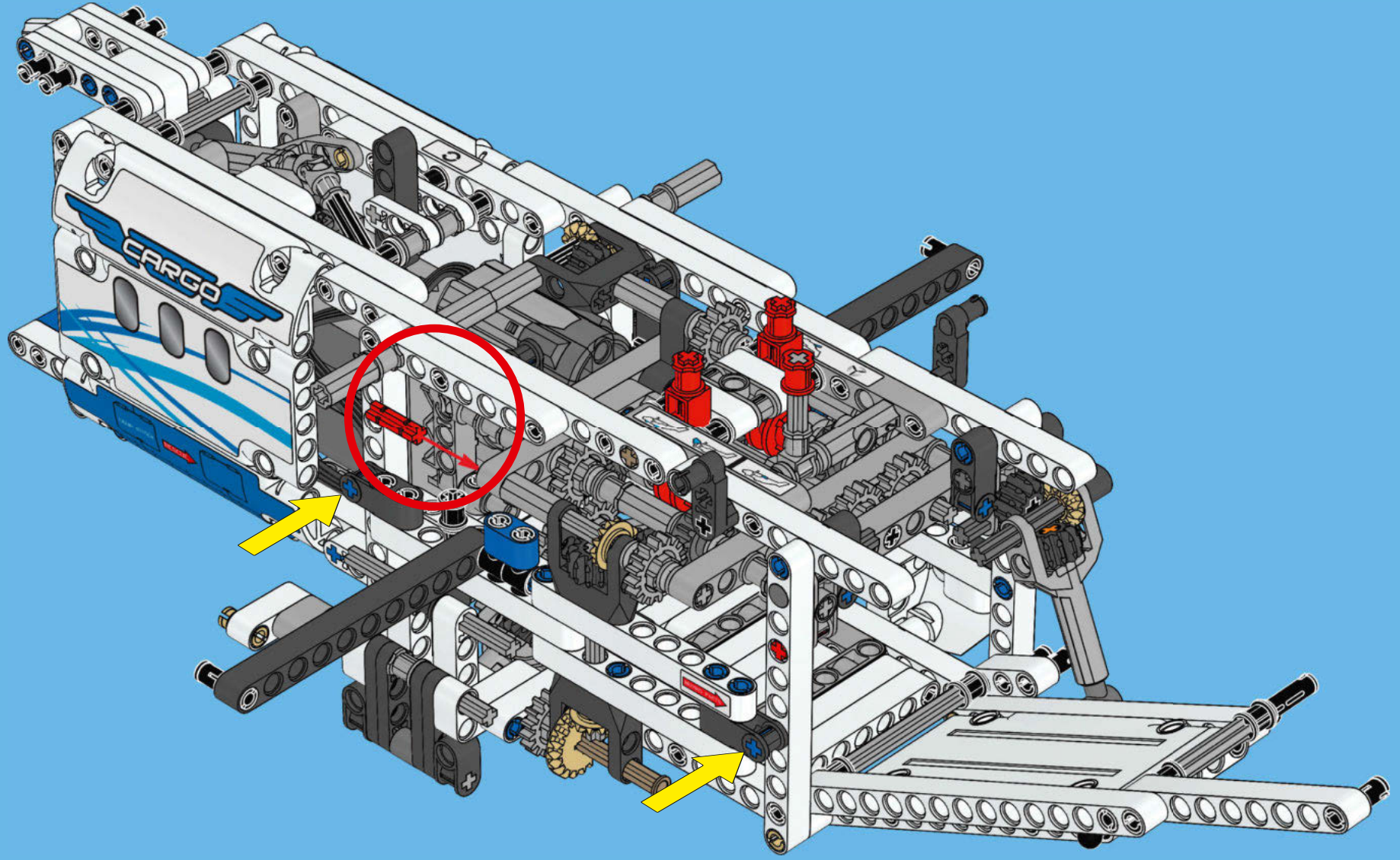



# 43

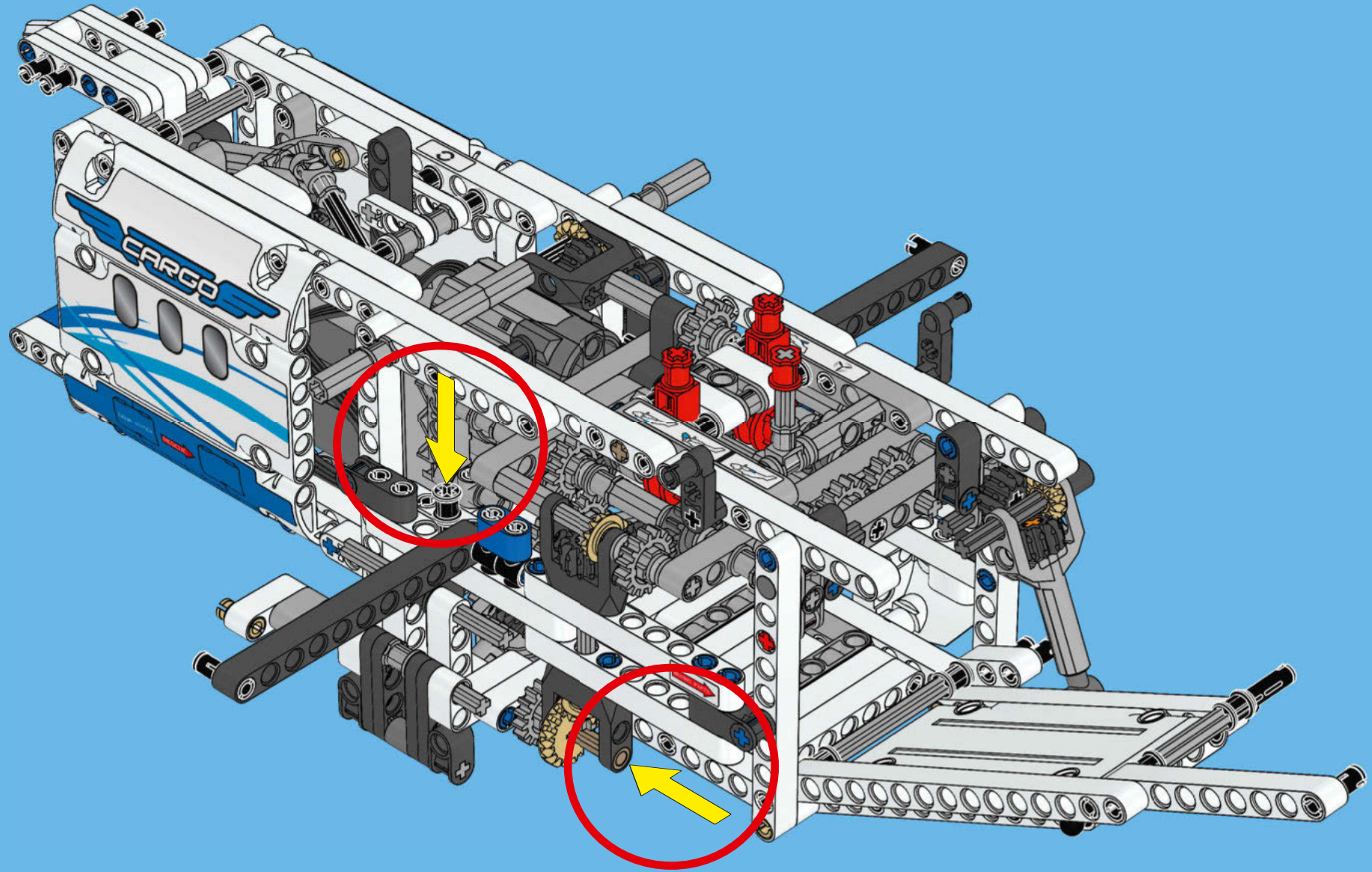



1x



1x



1x



1x

# 44

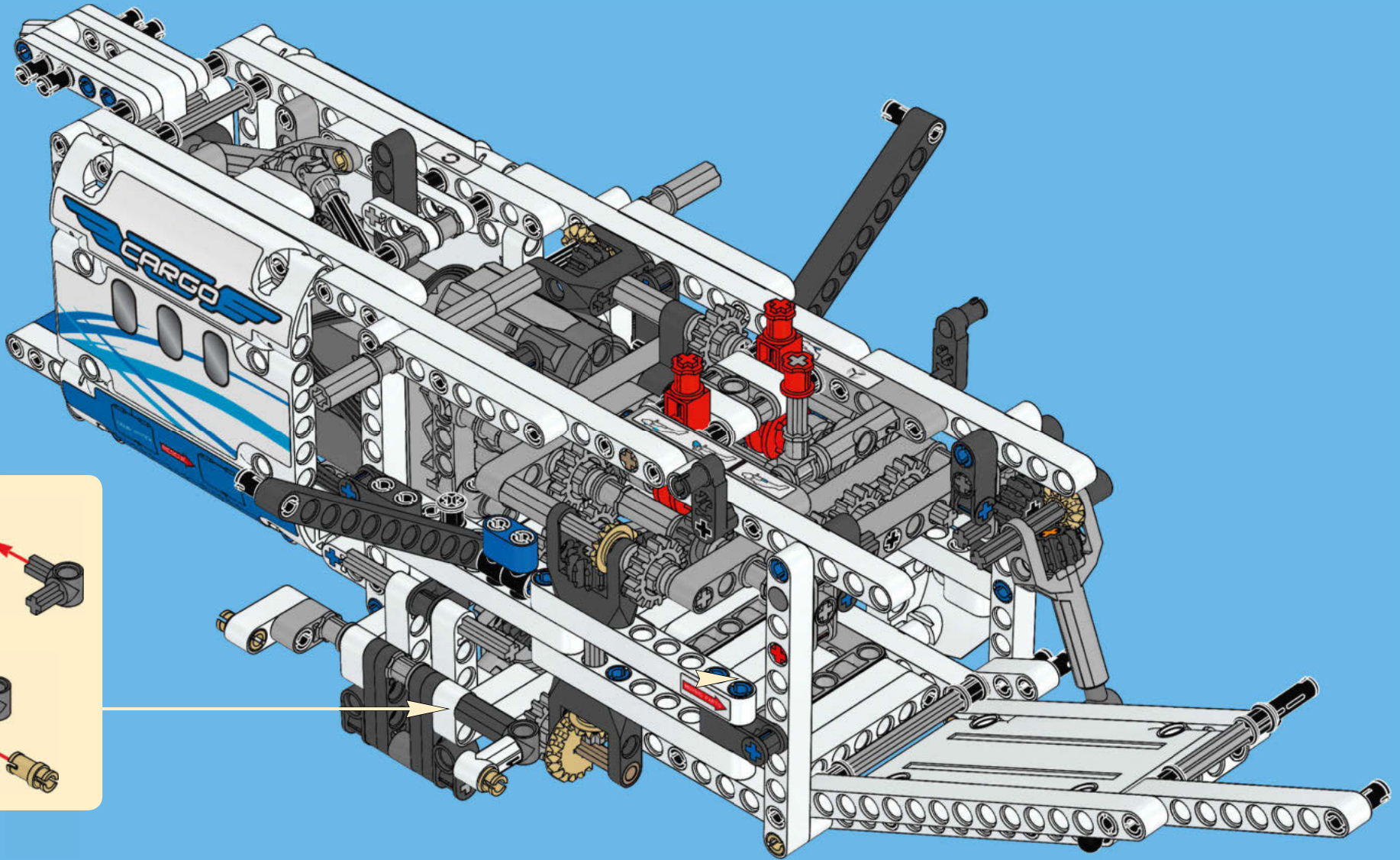

1

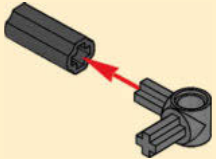

2

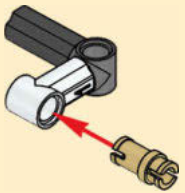

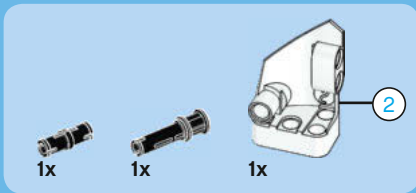

45

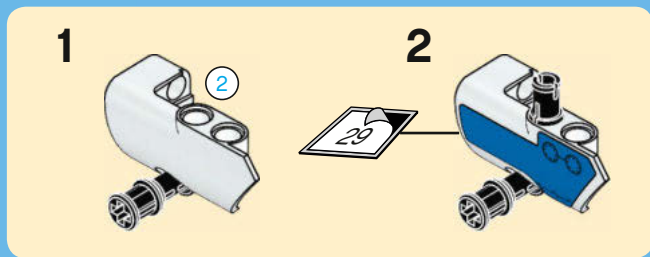
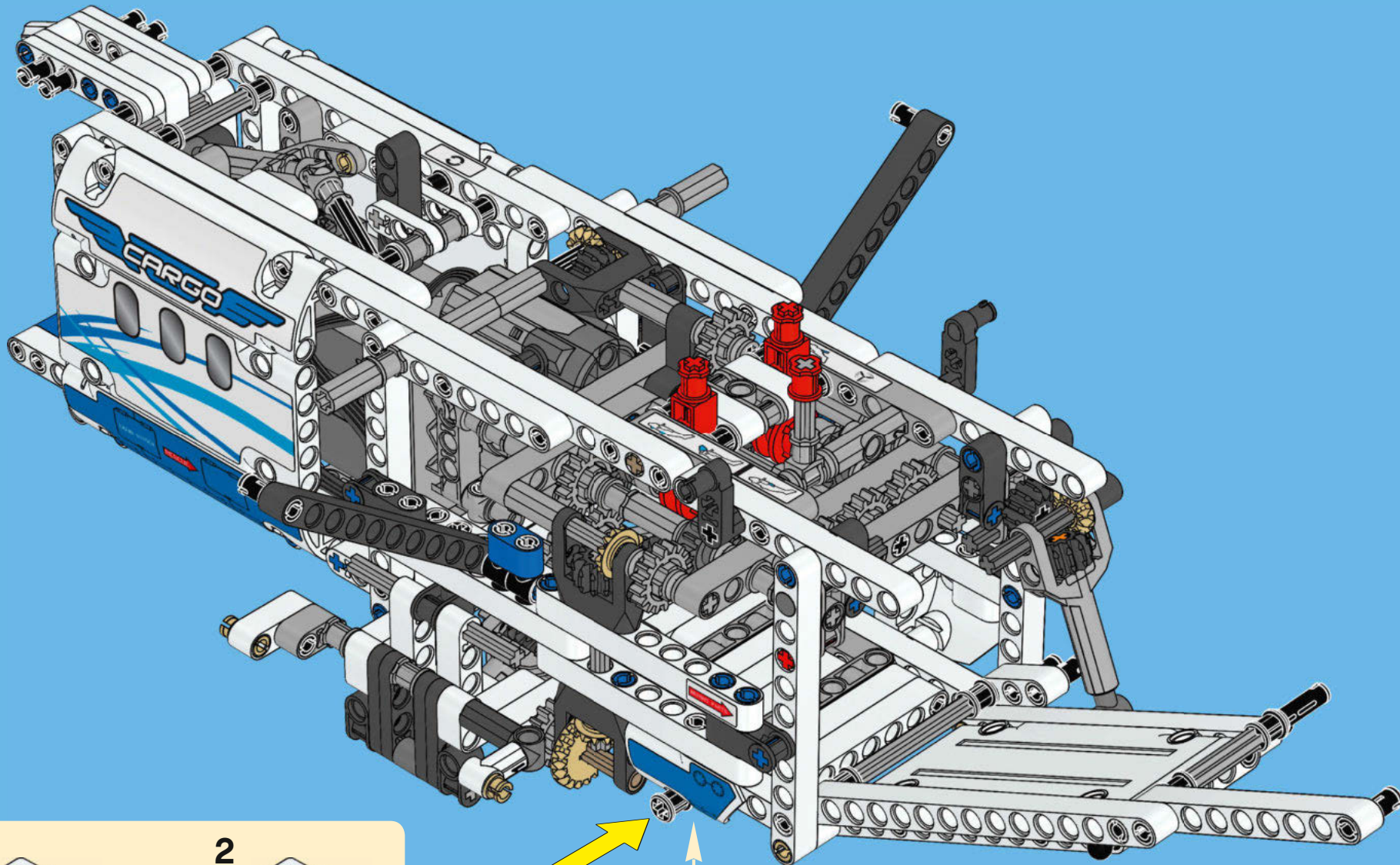

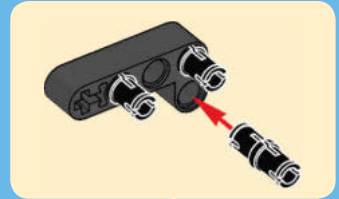
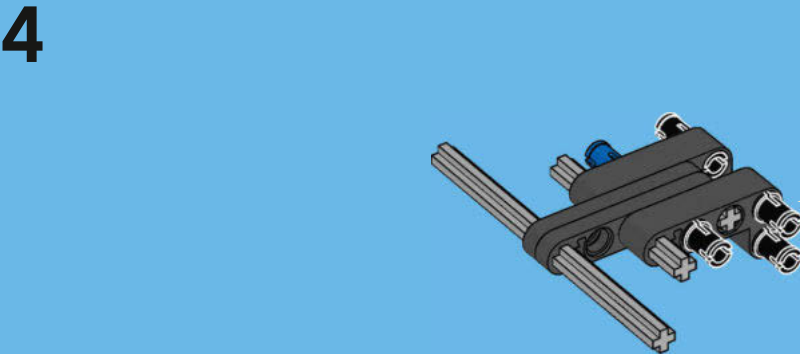
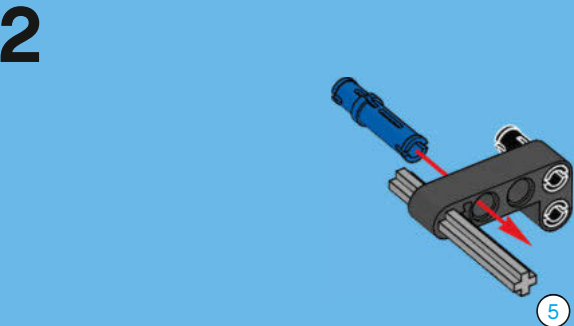
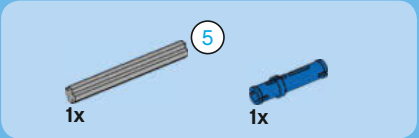
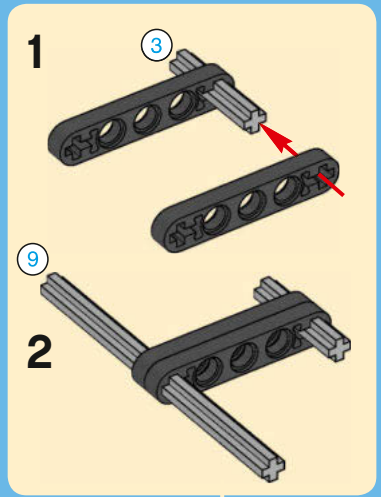
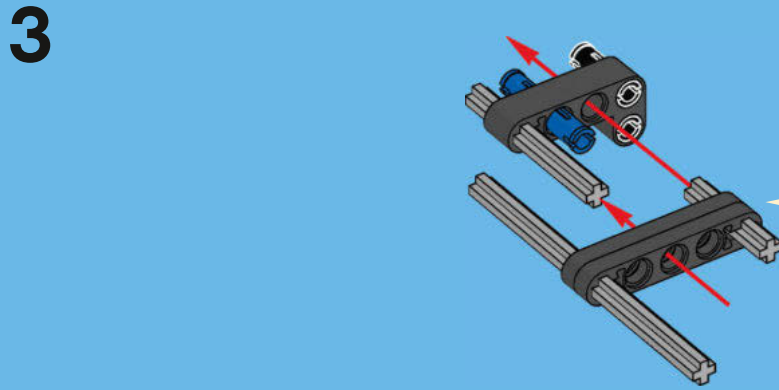
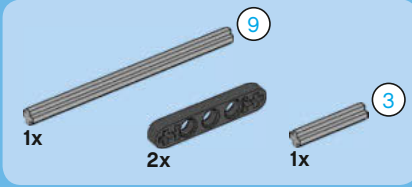
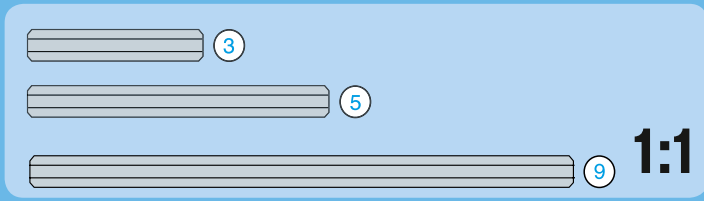
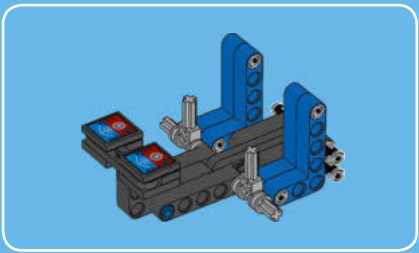

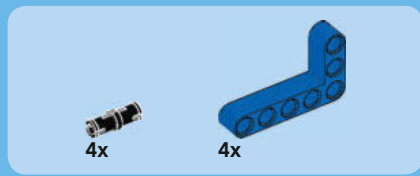

5

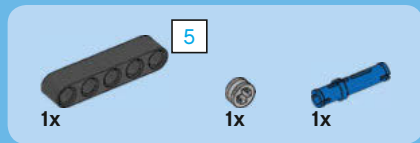
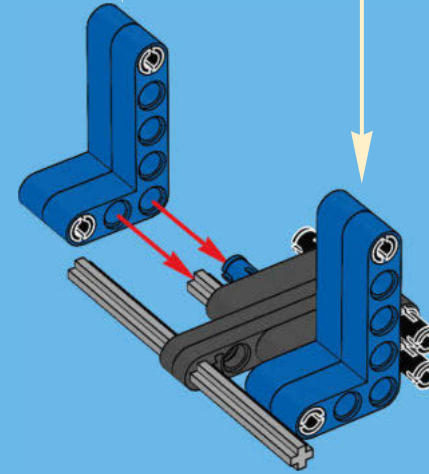
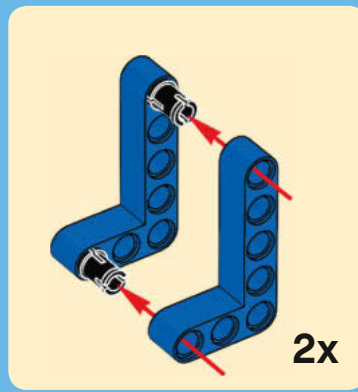

6

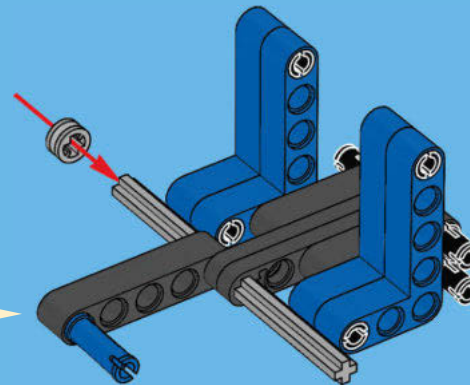
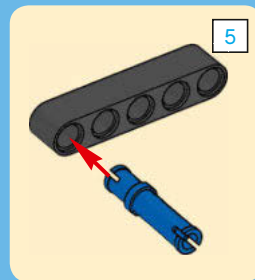
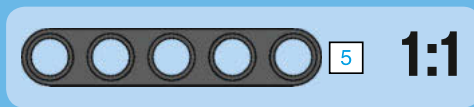

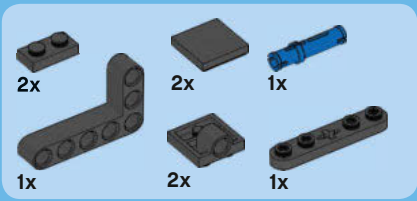

7

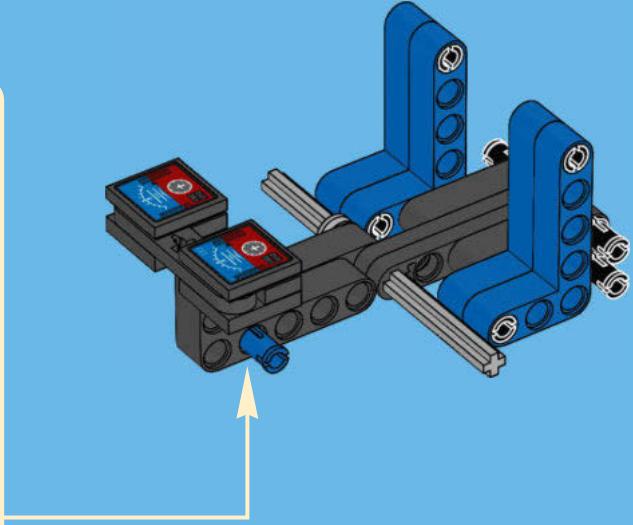
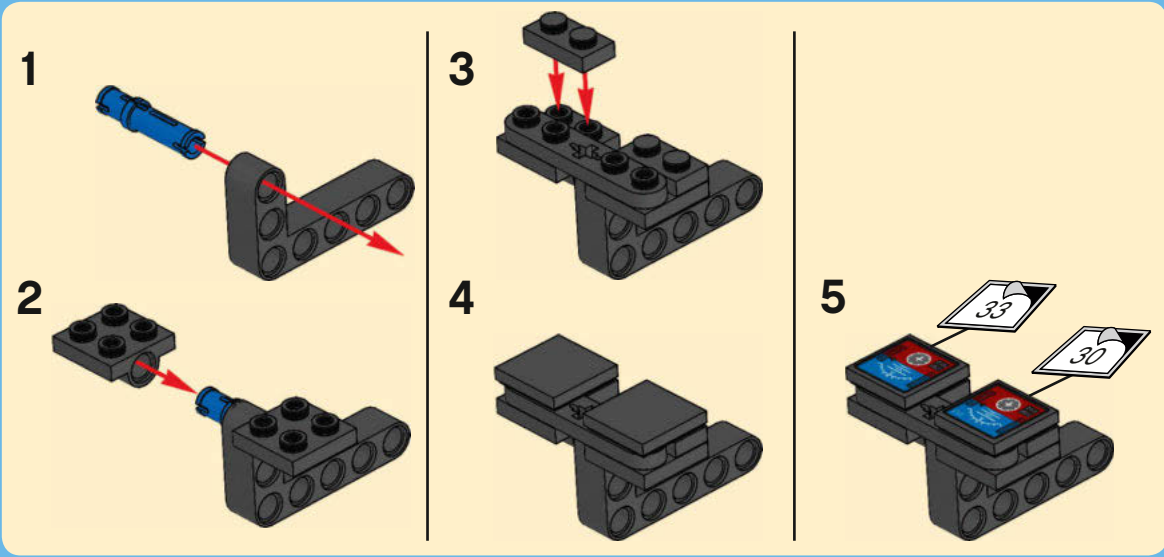

8

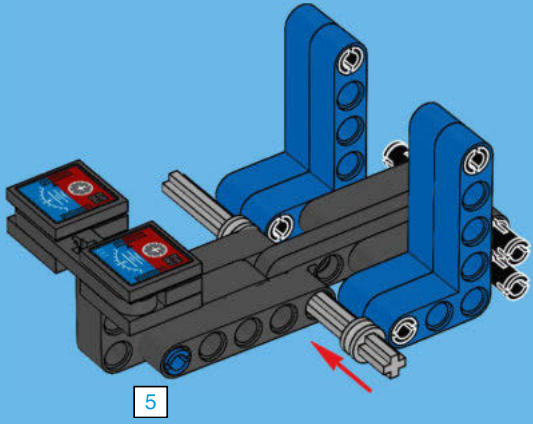



2x



2x

9

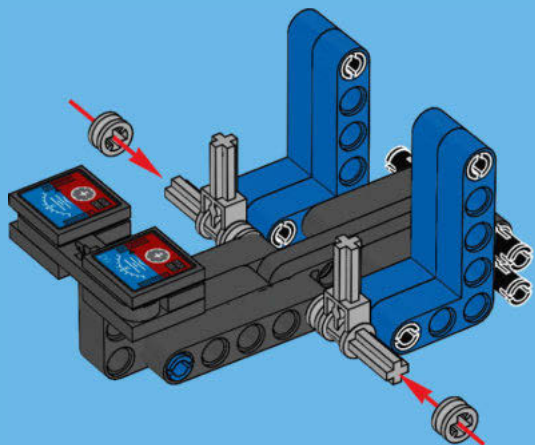

10

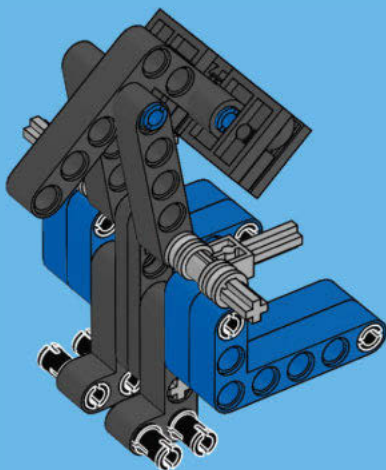

46

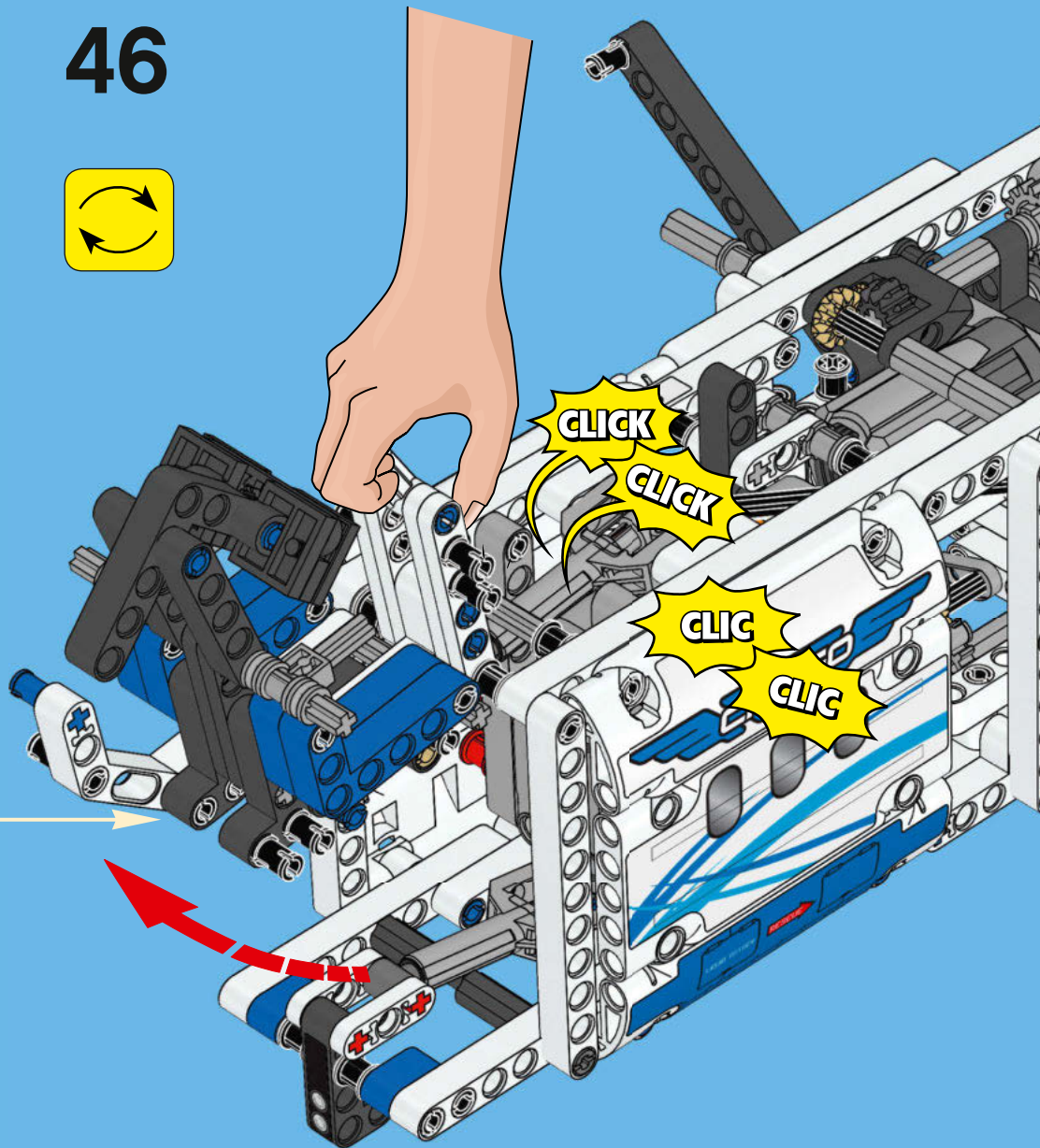

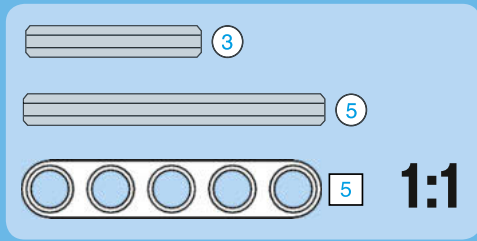
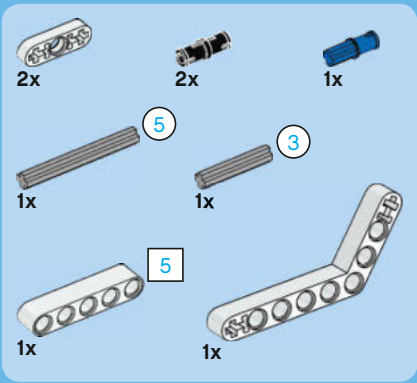

47

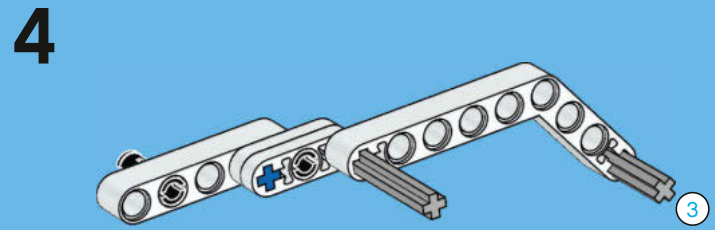
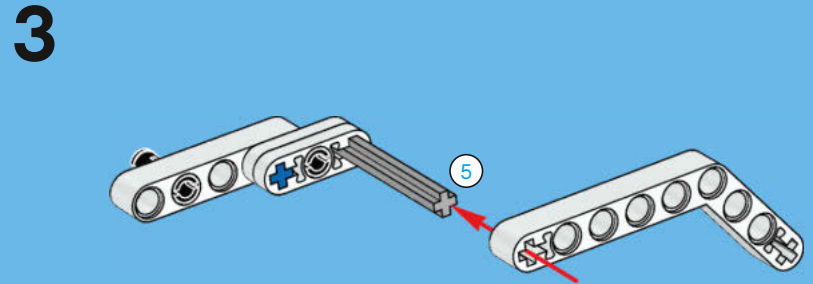
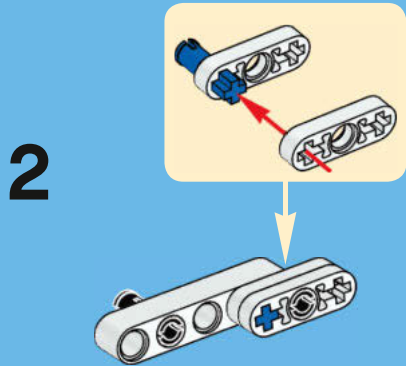
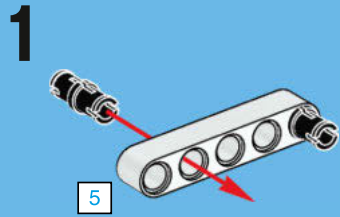



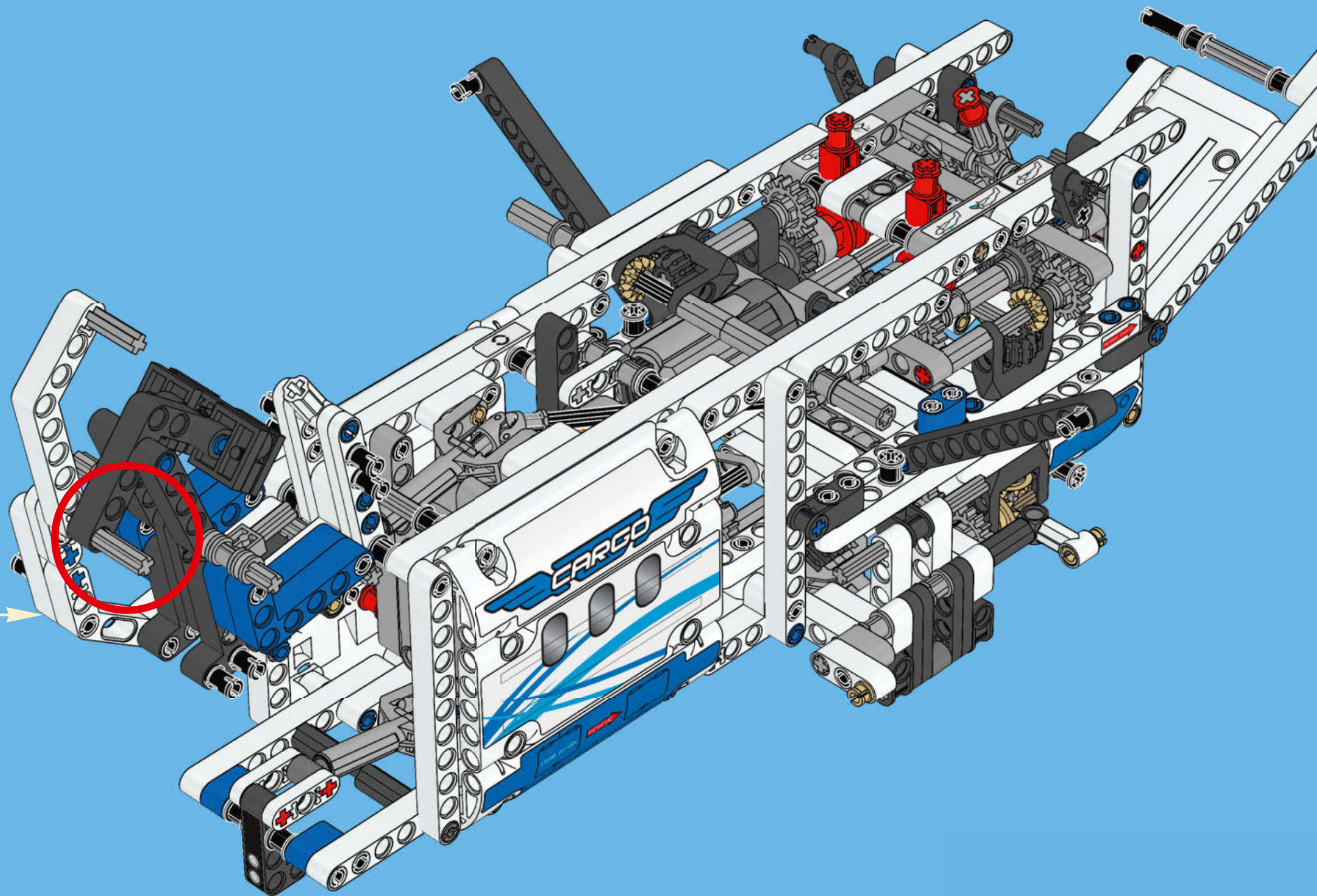

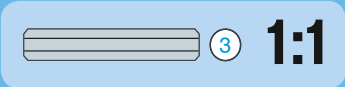
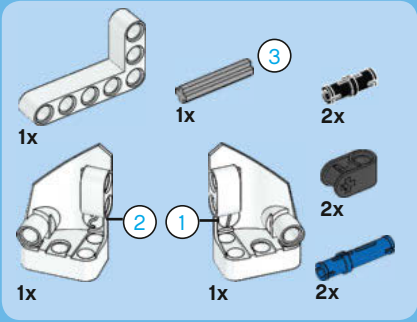

# 48

1

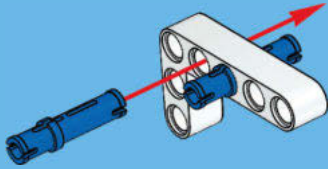

2

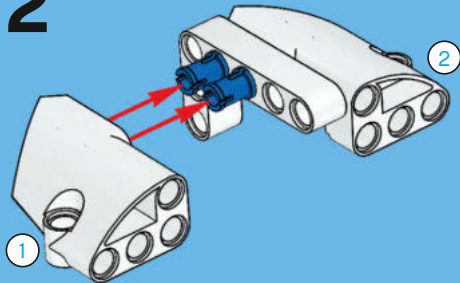

3

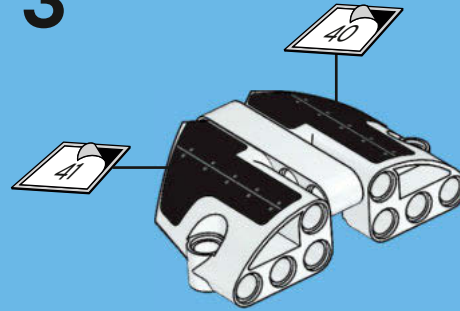

4

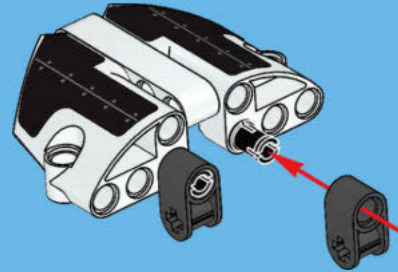

5

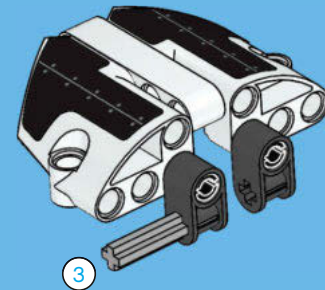

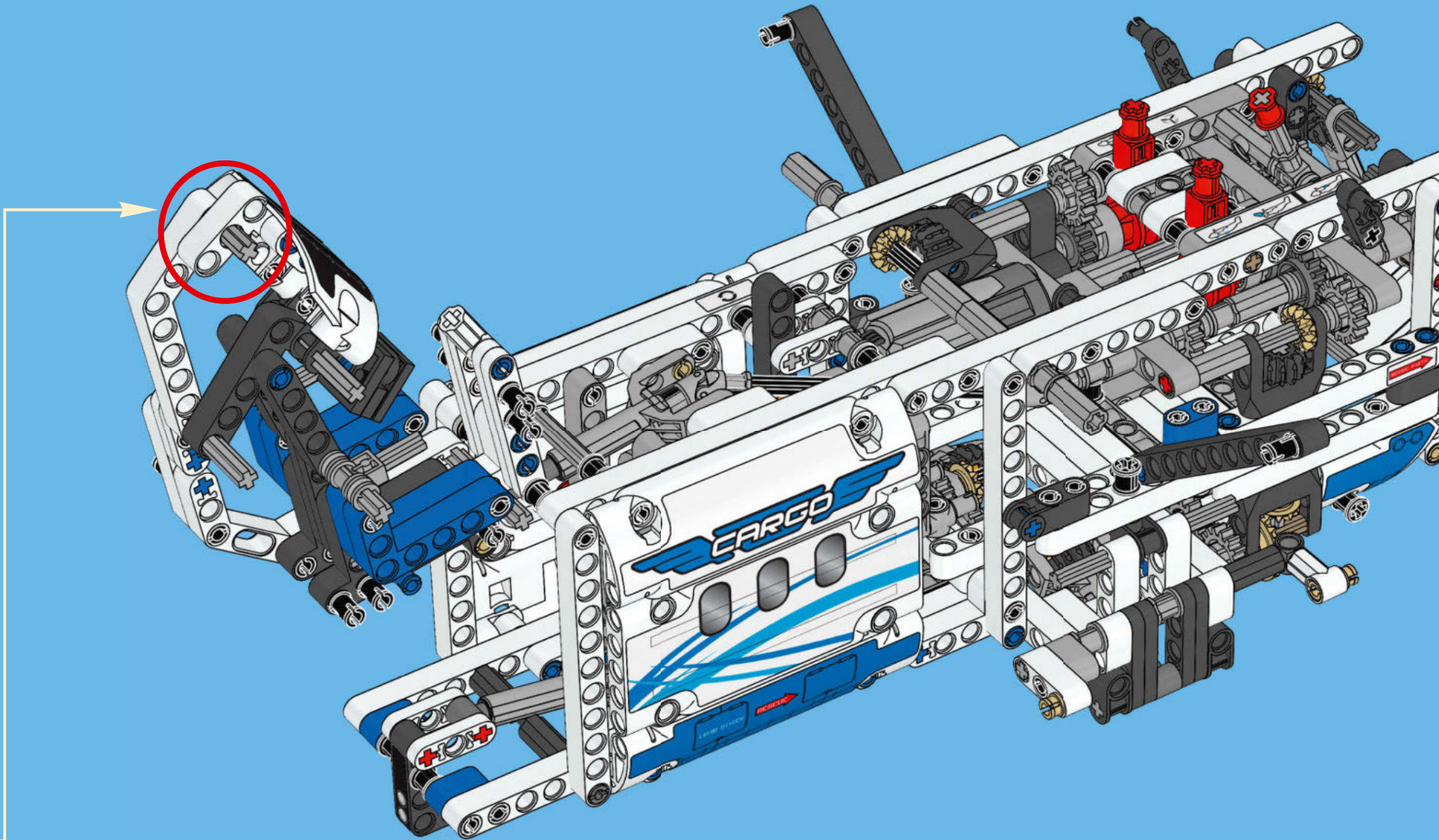

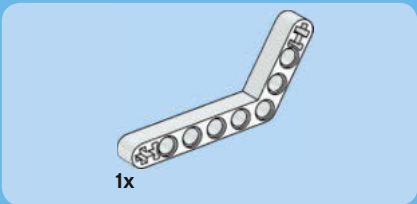

49

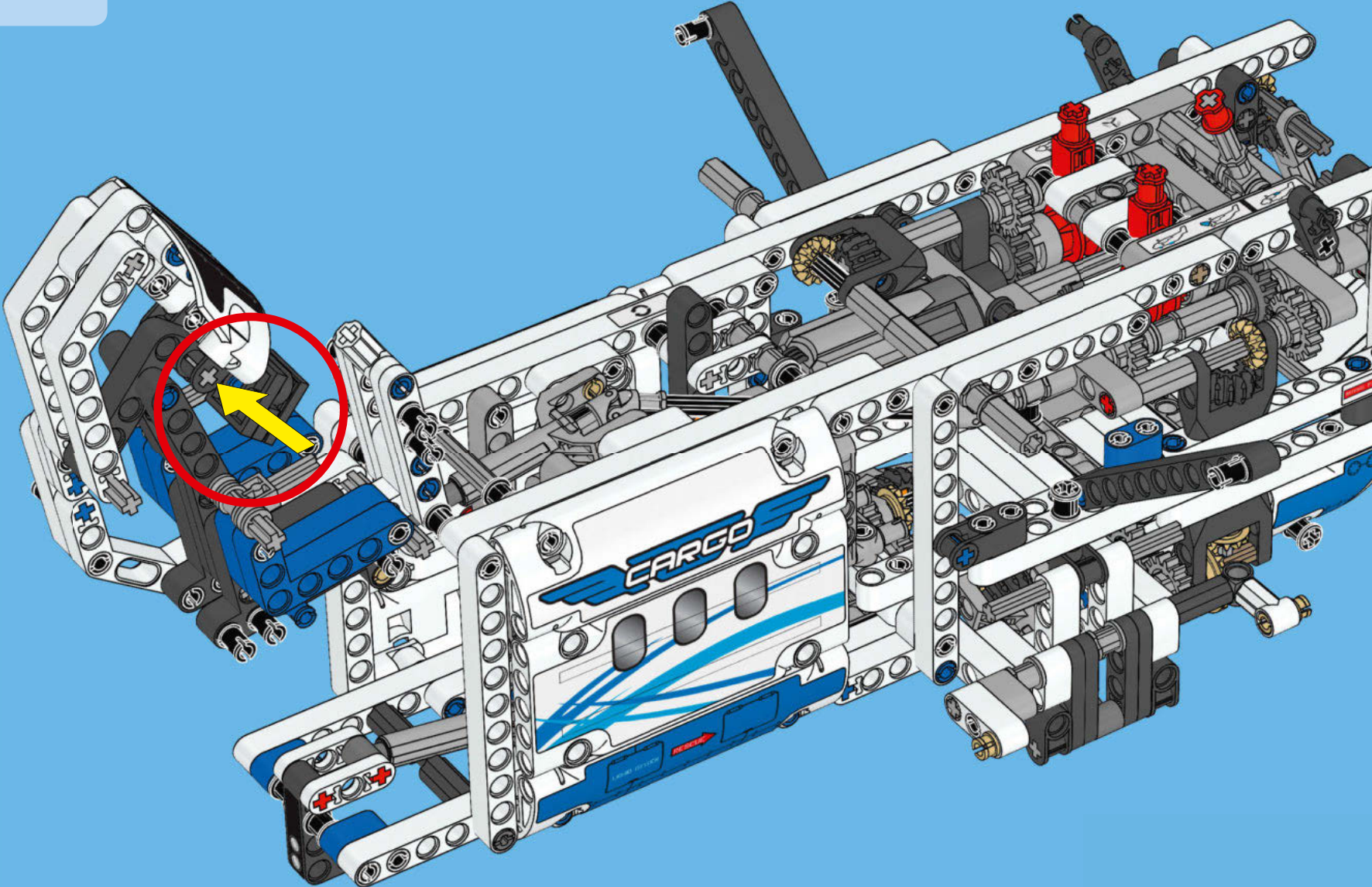

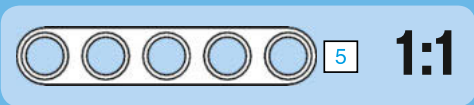
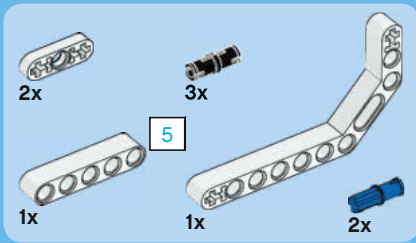

50

1

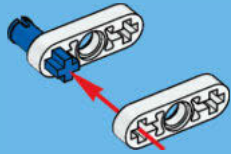

2

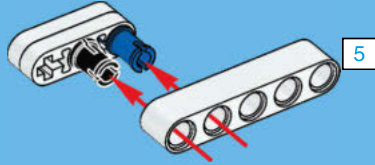

3



4

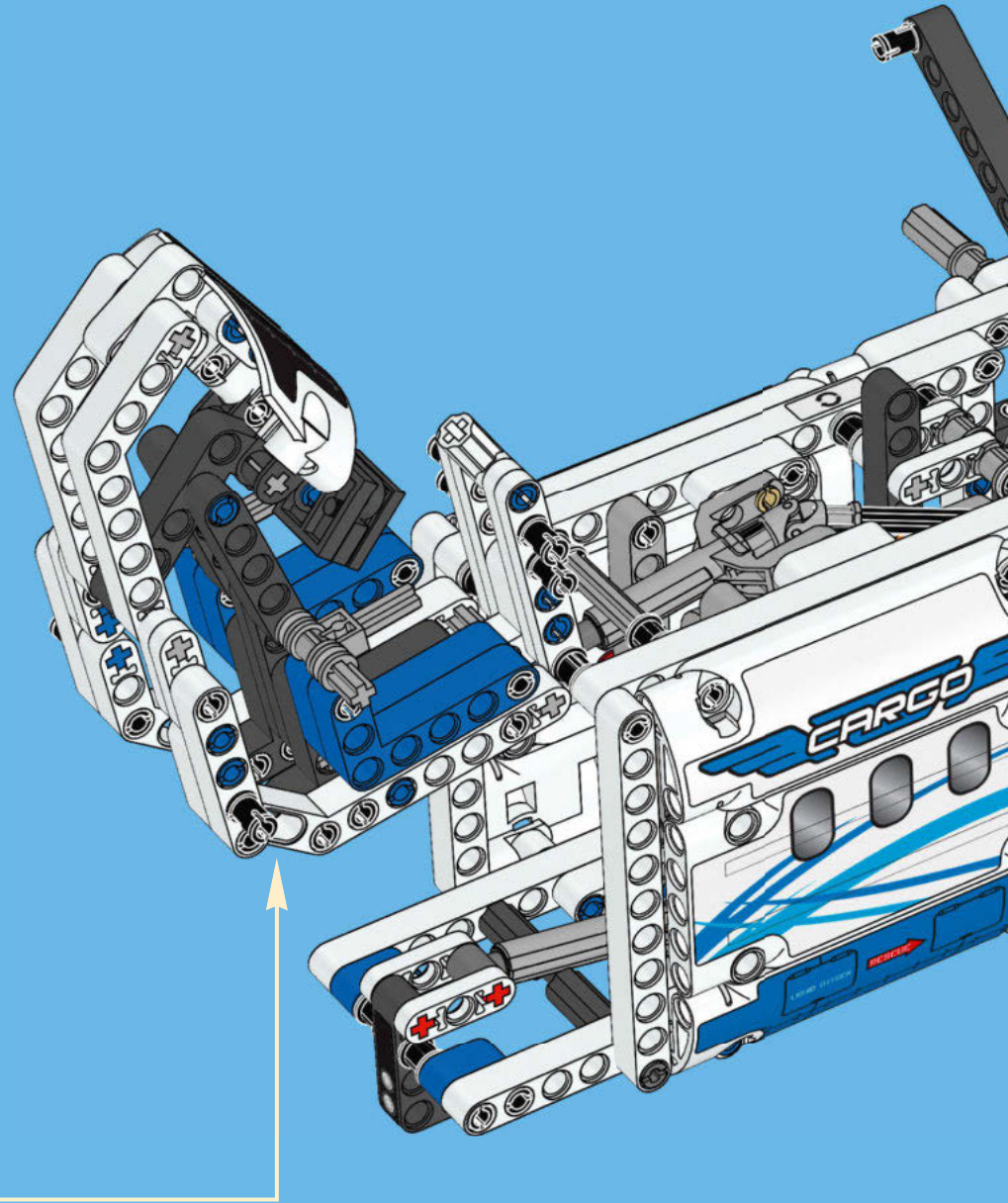
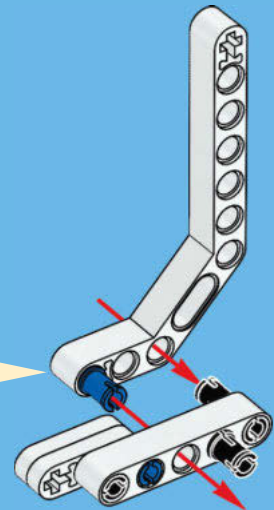
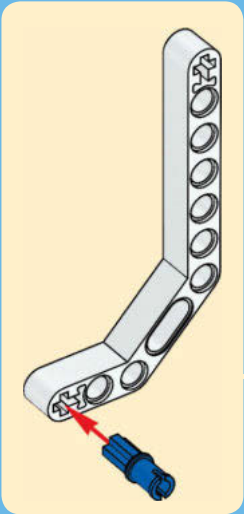

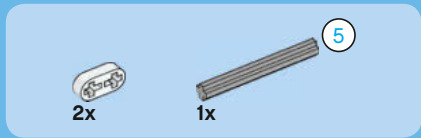

1

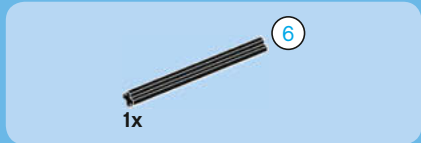
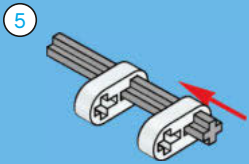

2

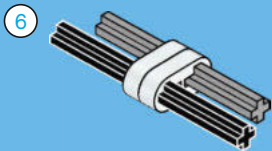

3

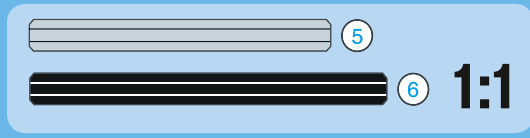
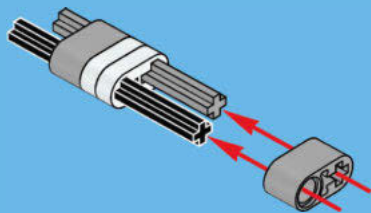

4

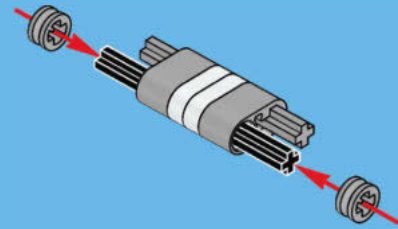

5

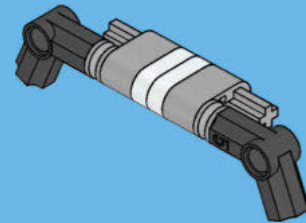

6

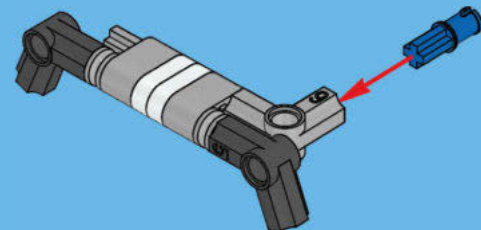

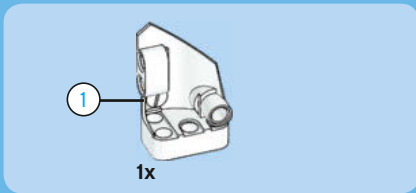

7

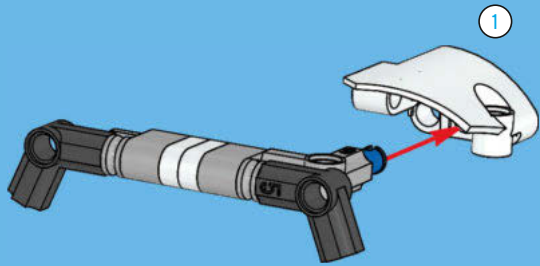

8

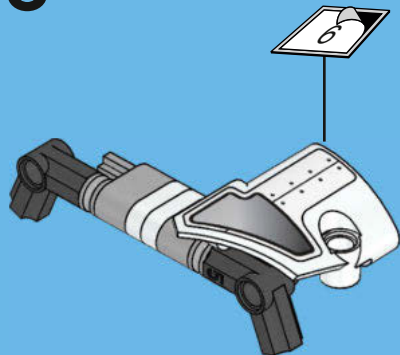

51

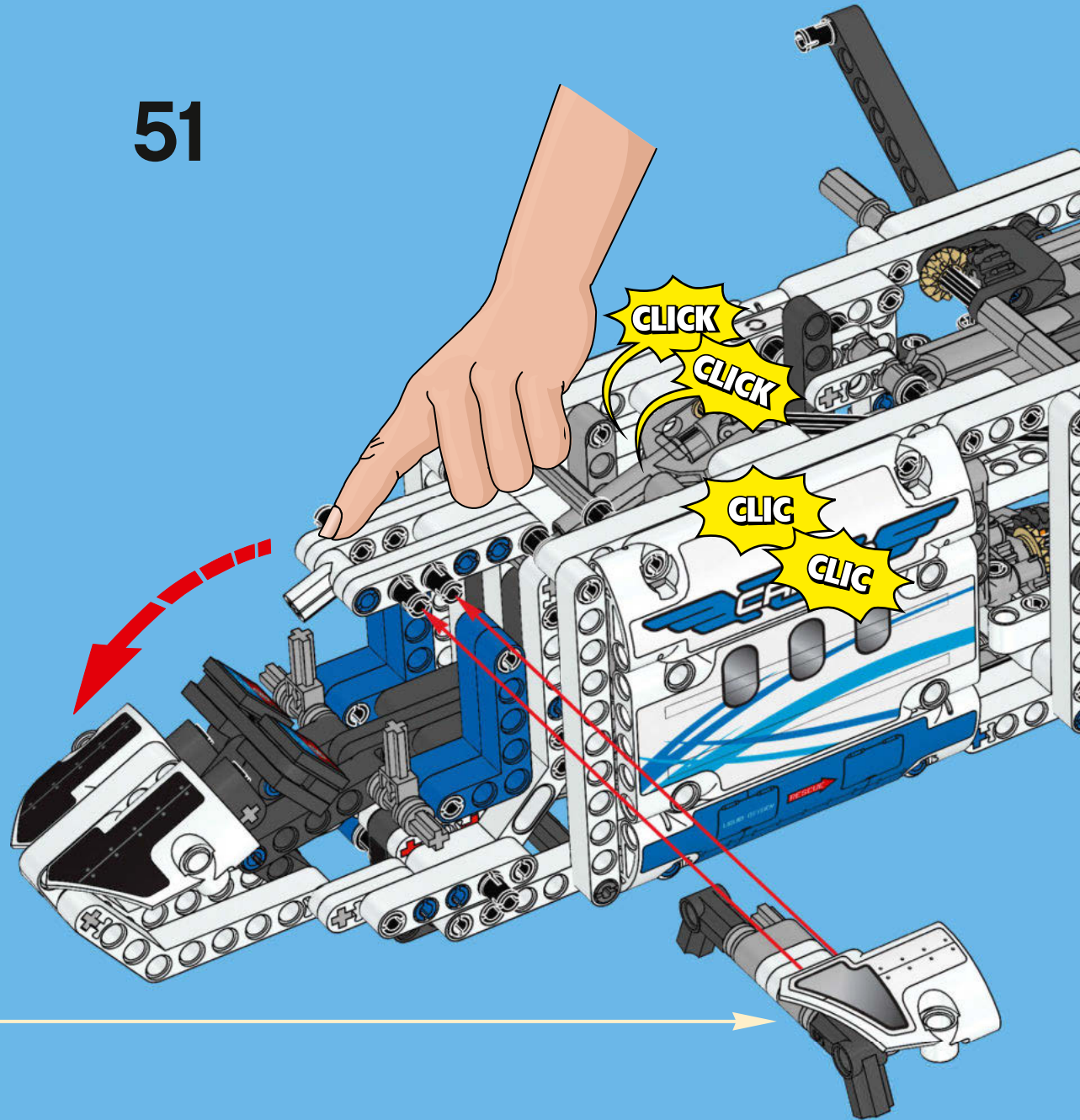

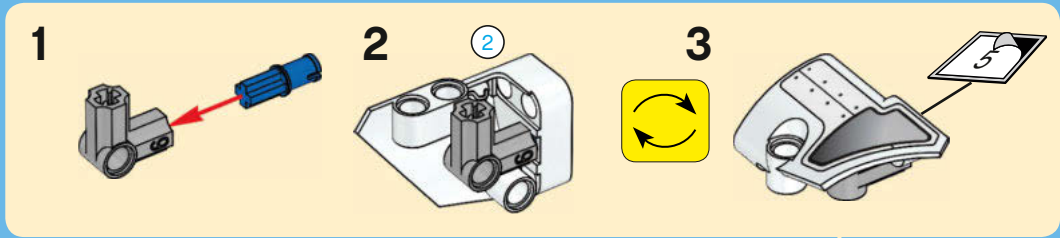
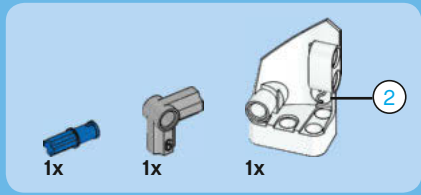

52

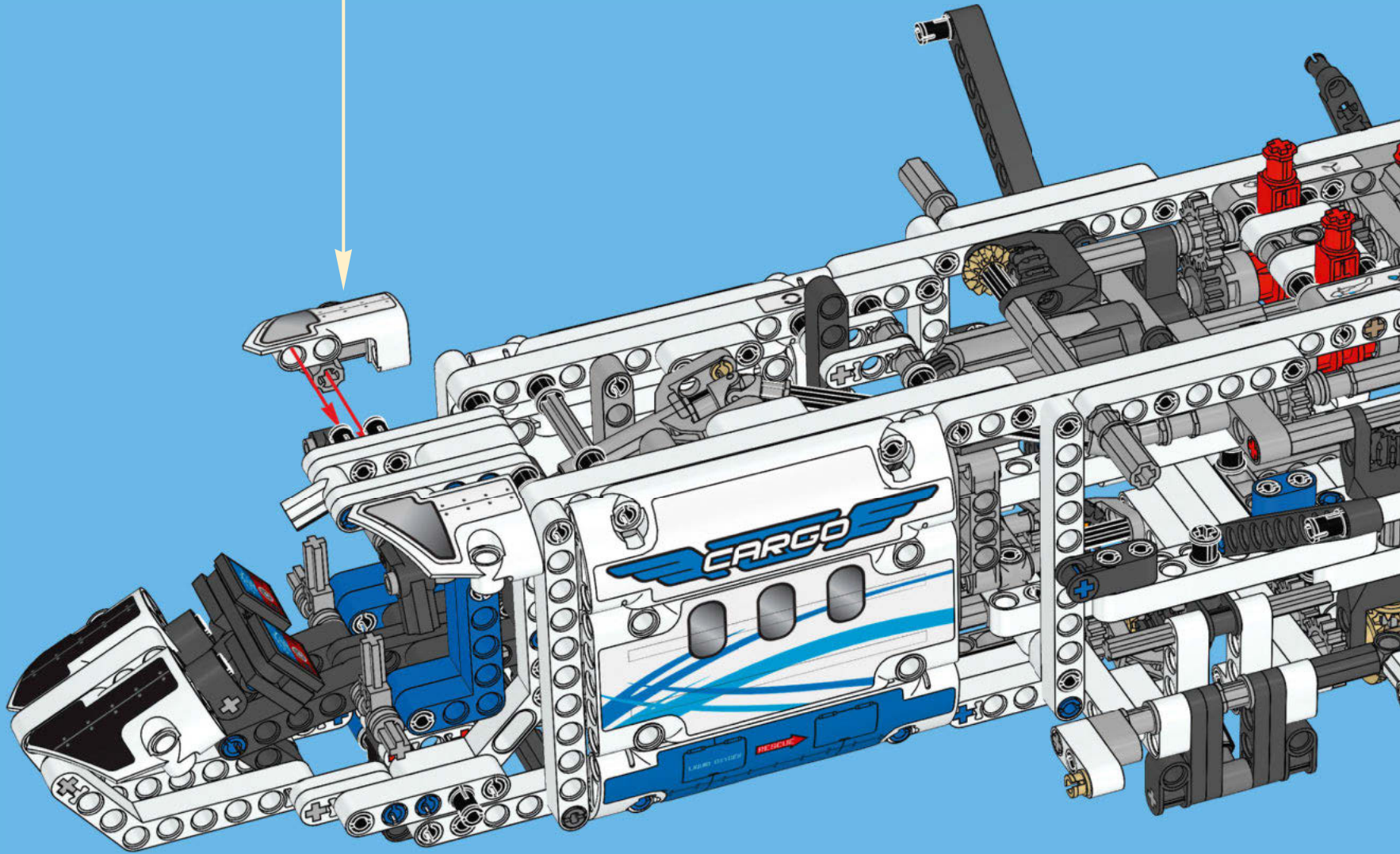



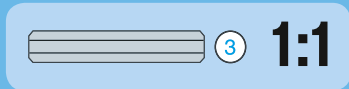
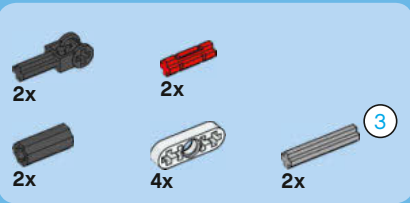

# 53

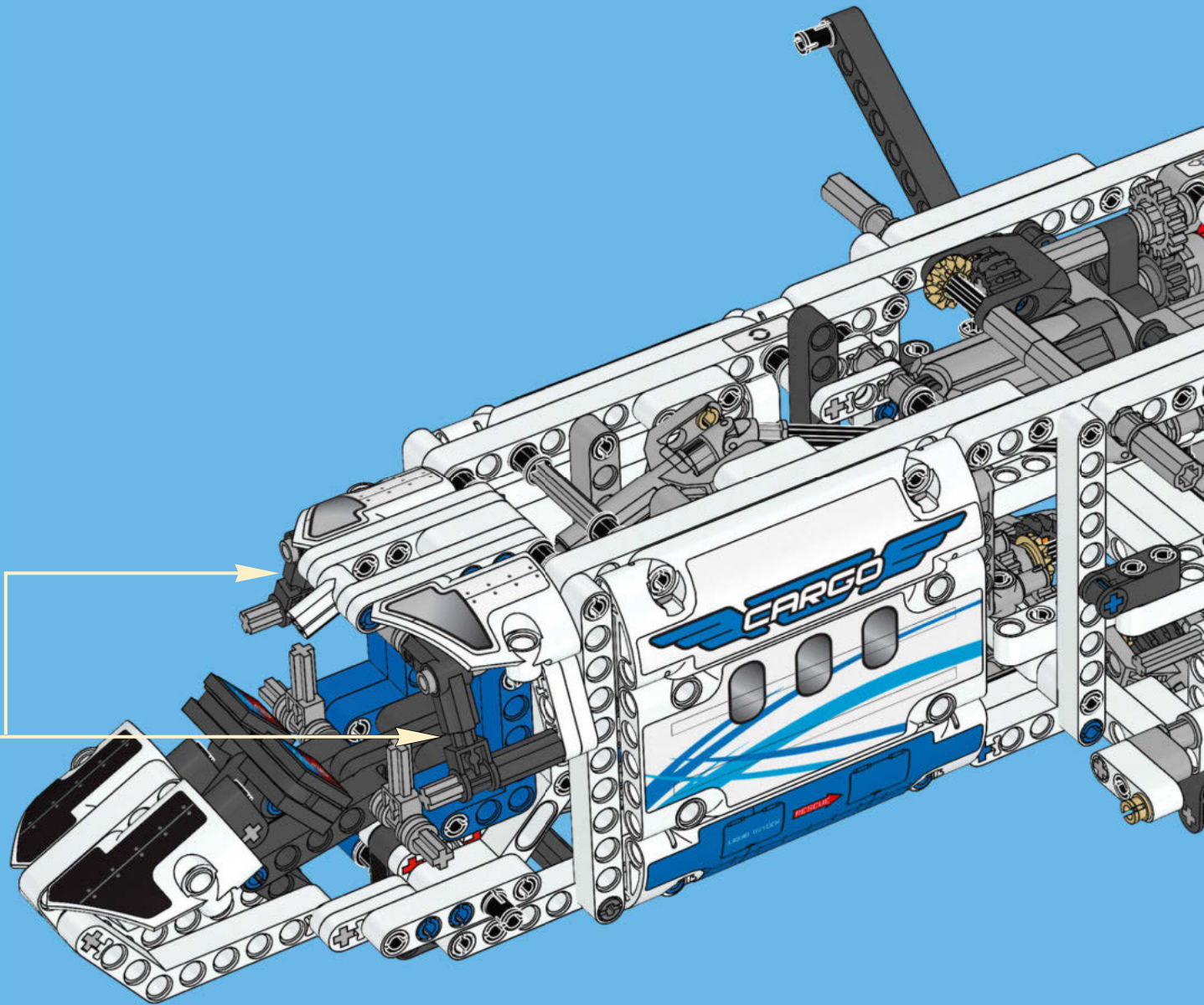
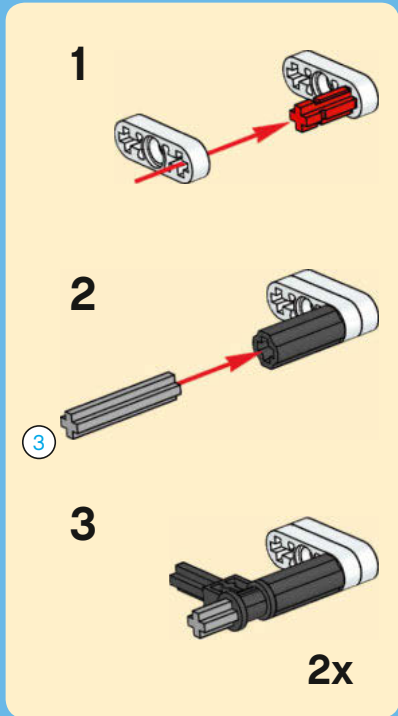



2x



3

1:1

# 54

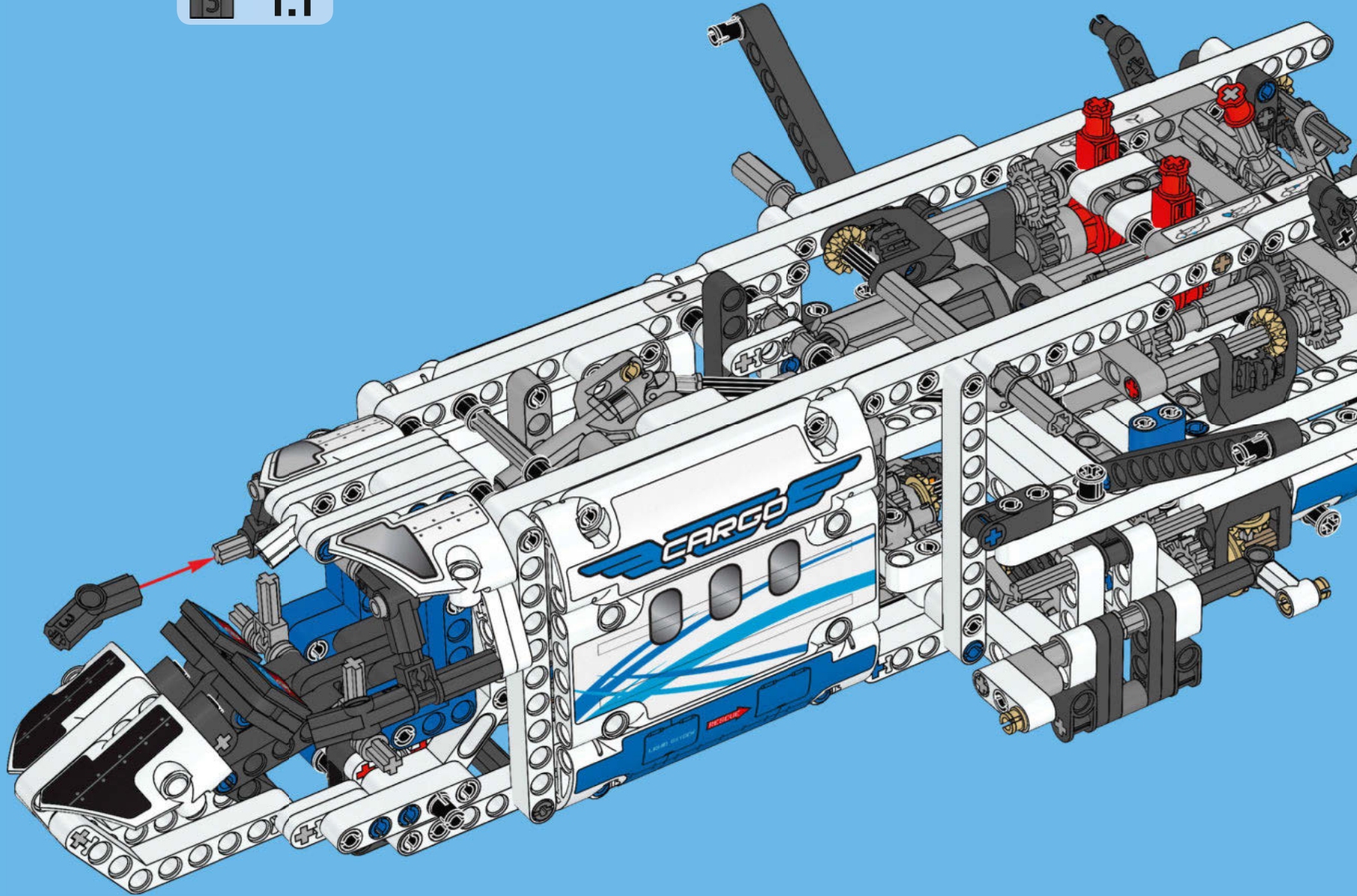

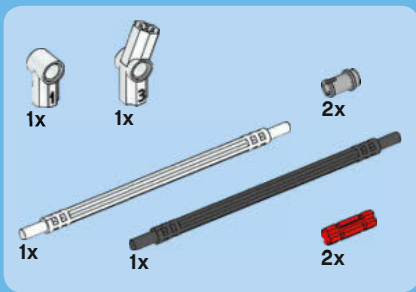

# 55

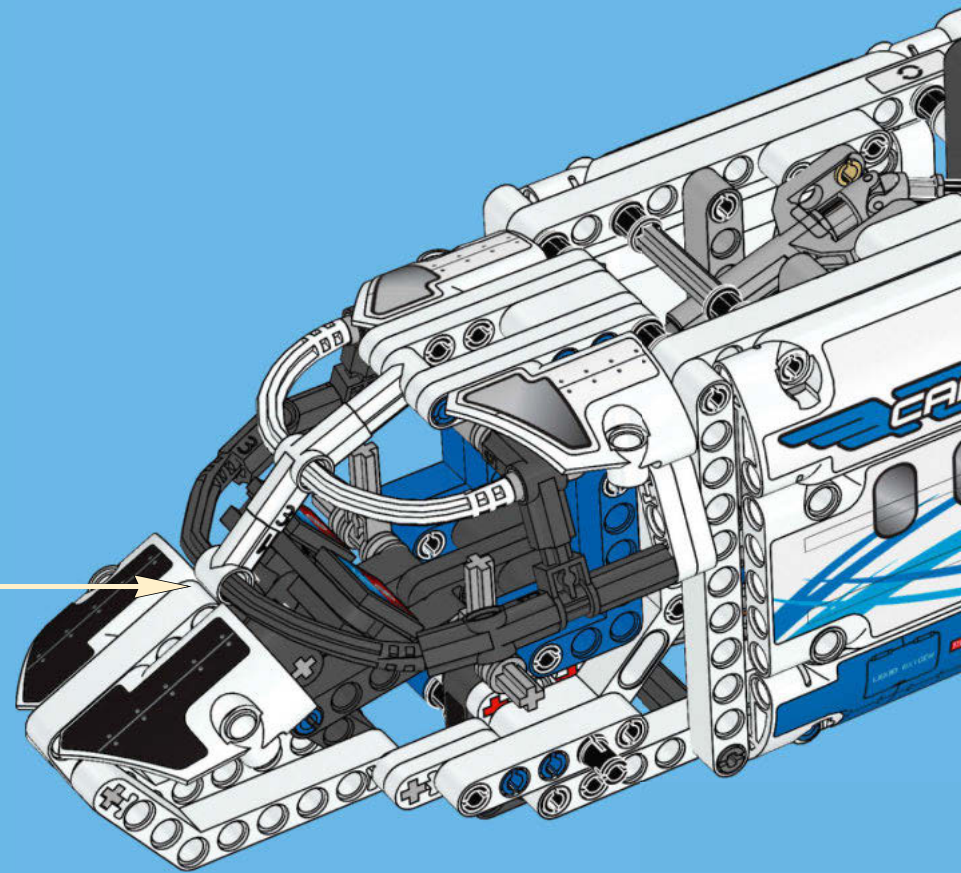
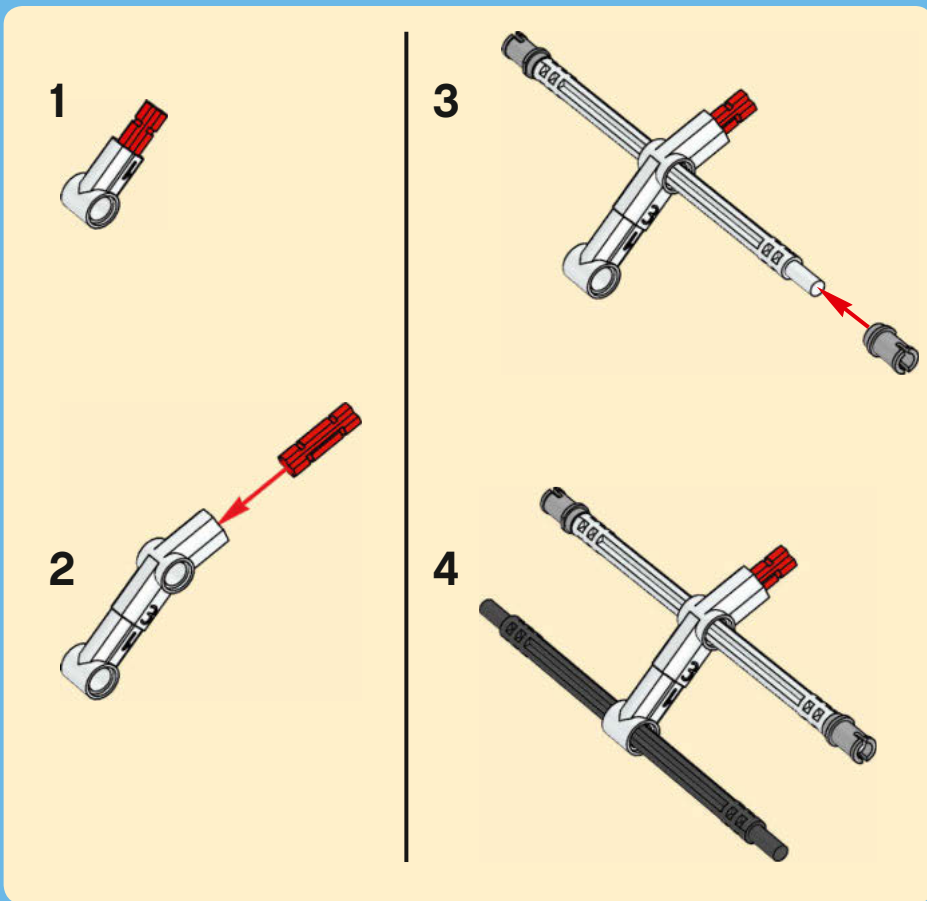

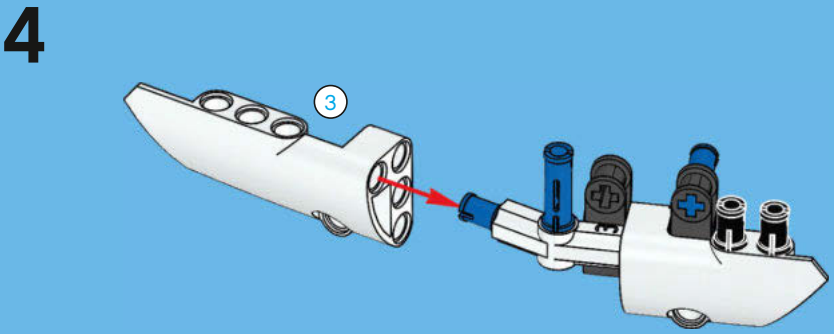
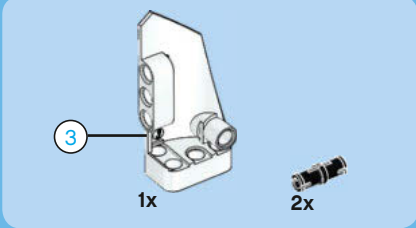
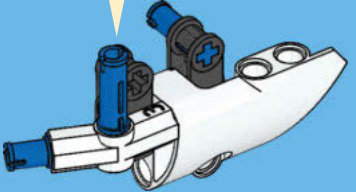
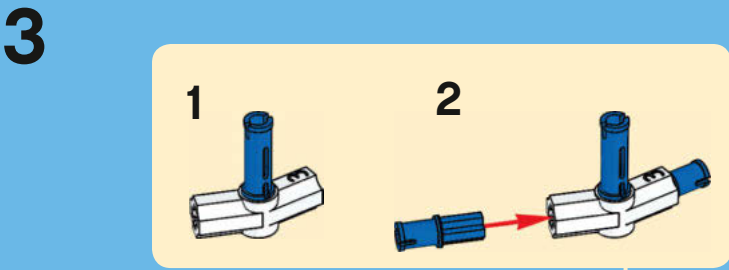
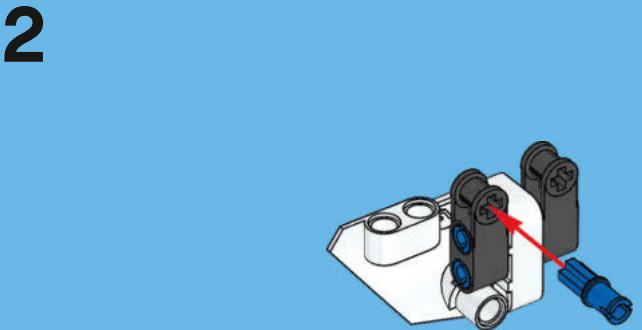
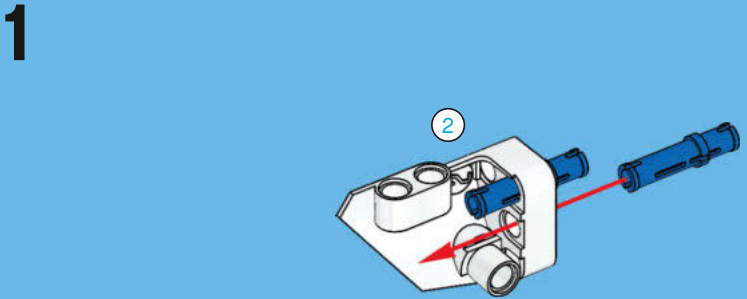
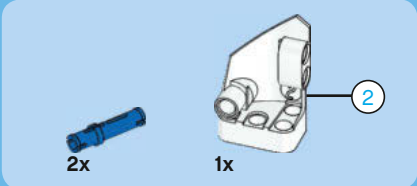
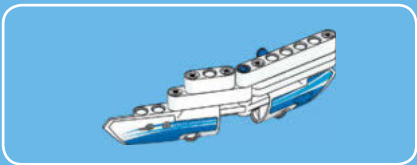



5

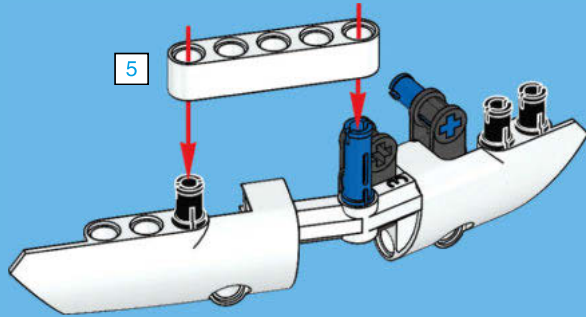
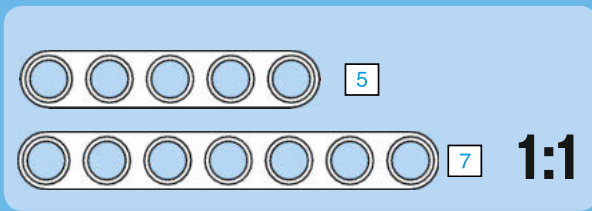

7

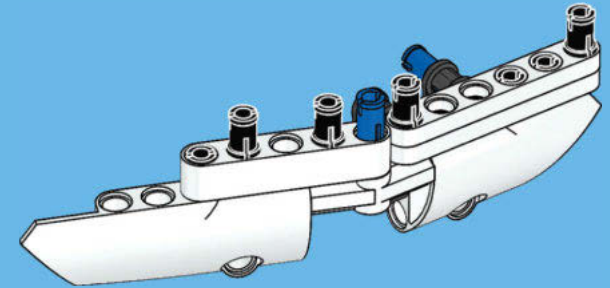

6

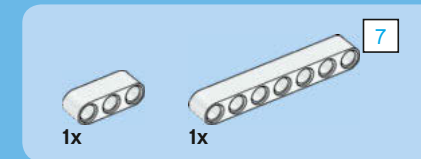
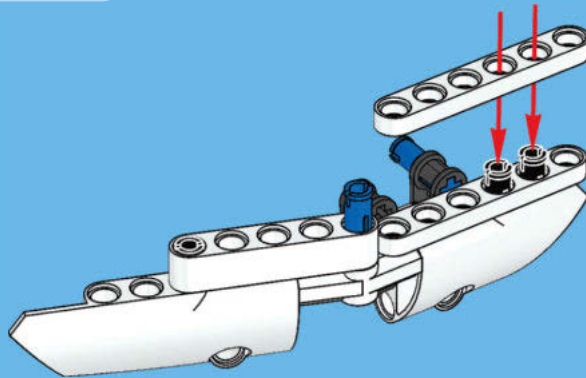
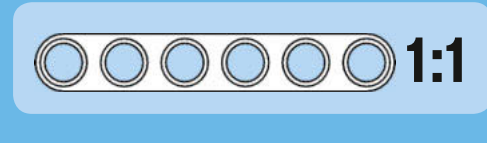

8

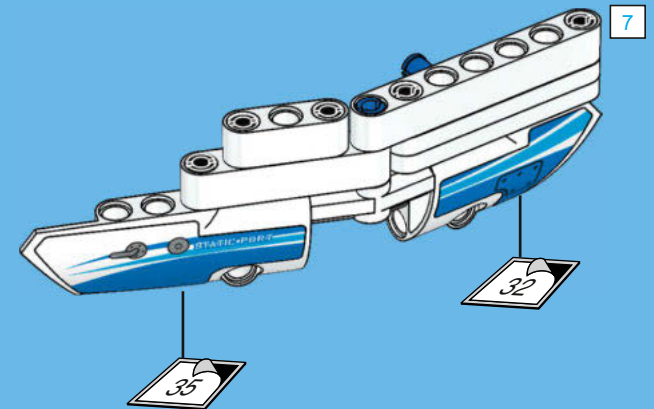

56

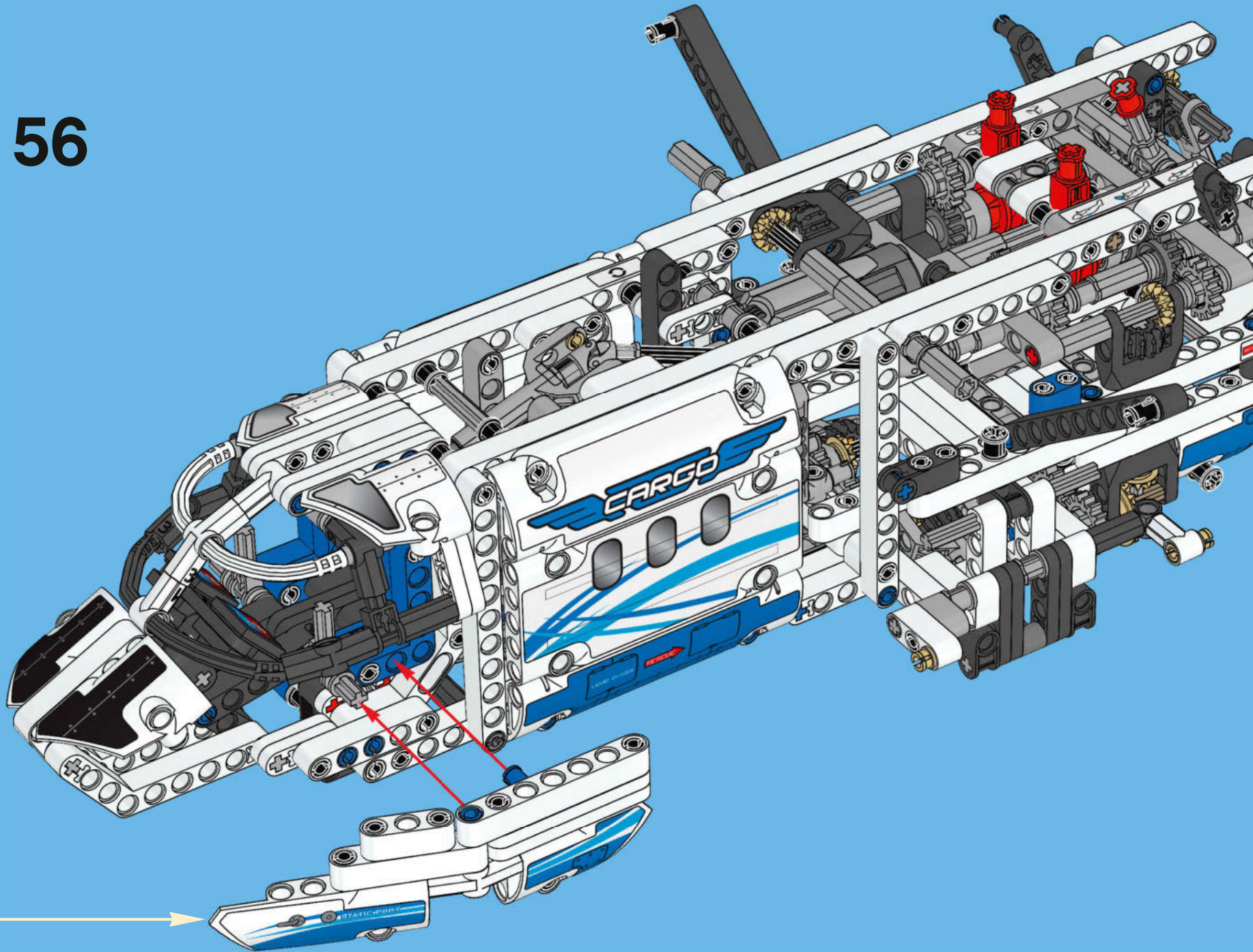

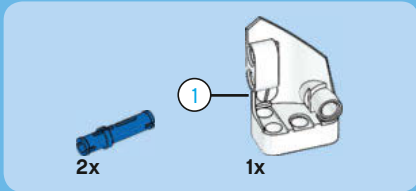
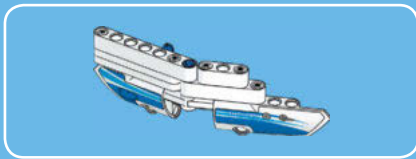

1

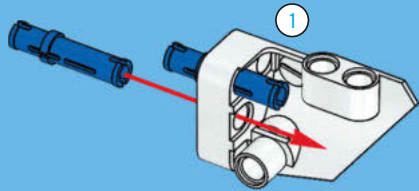

2

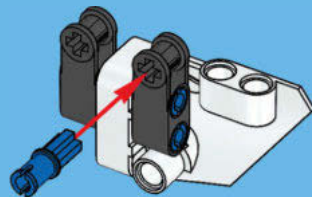

3

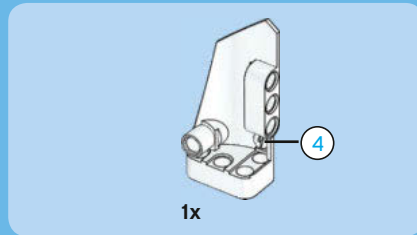
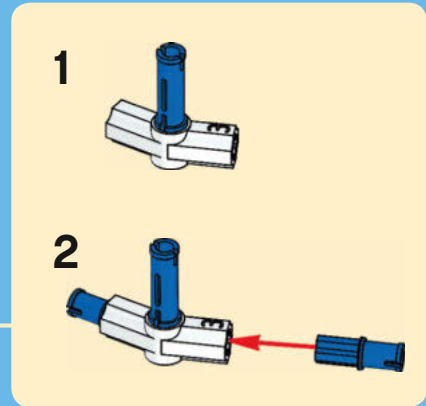
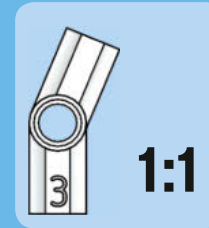
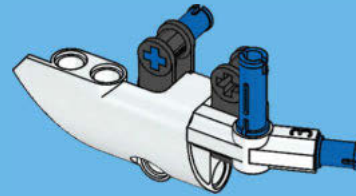

4

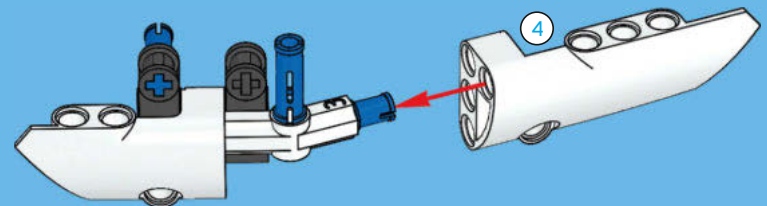



5

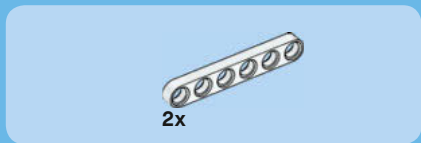
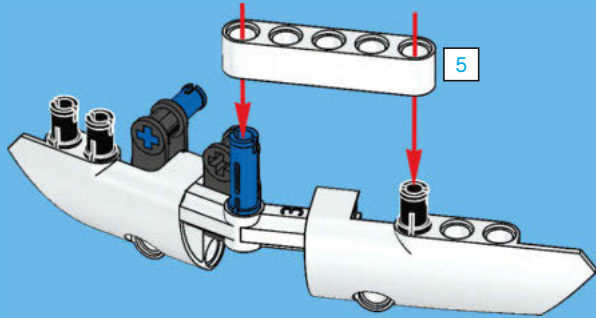
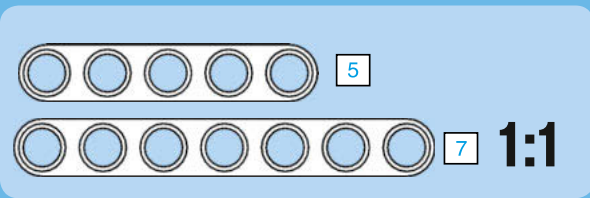

6

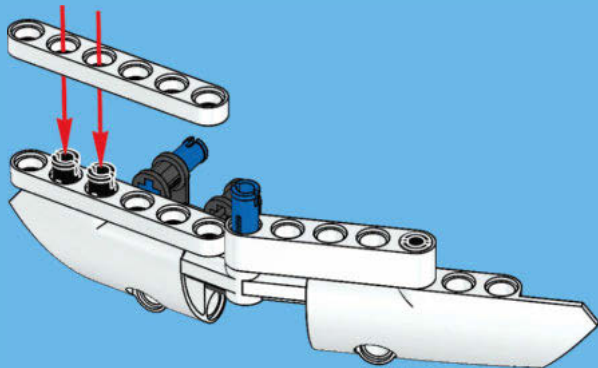

7

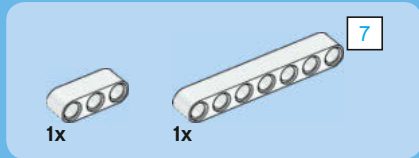
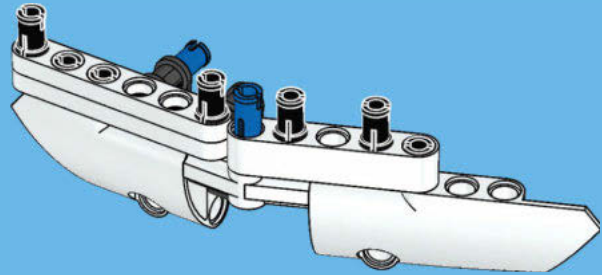

8

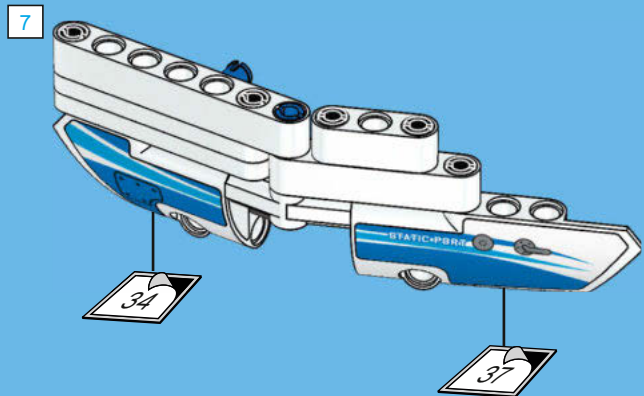
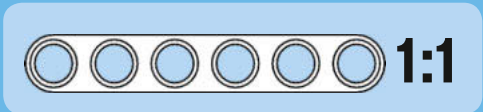



57

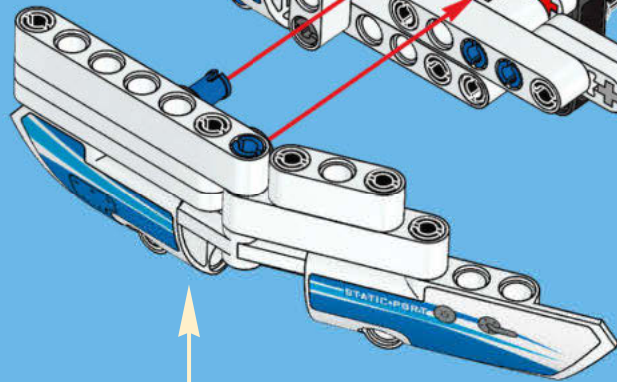

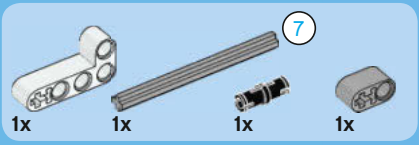

# 58

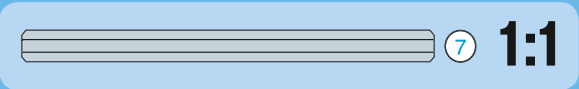
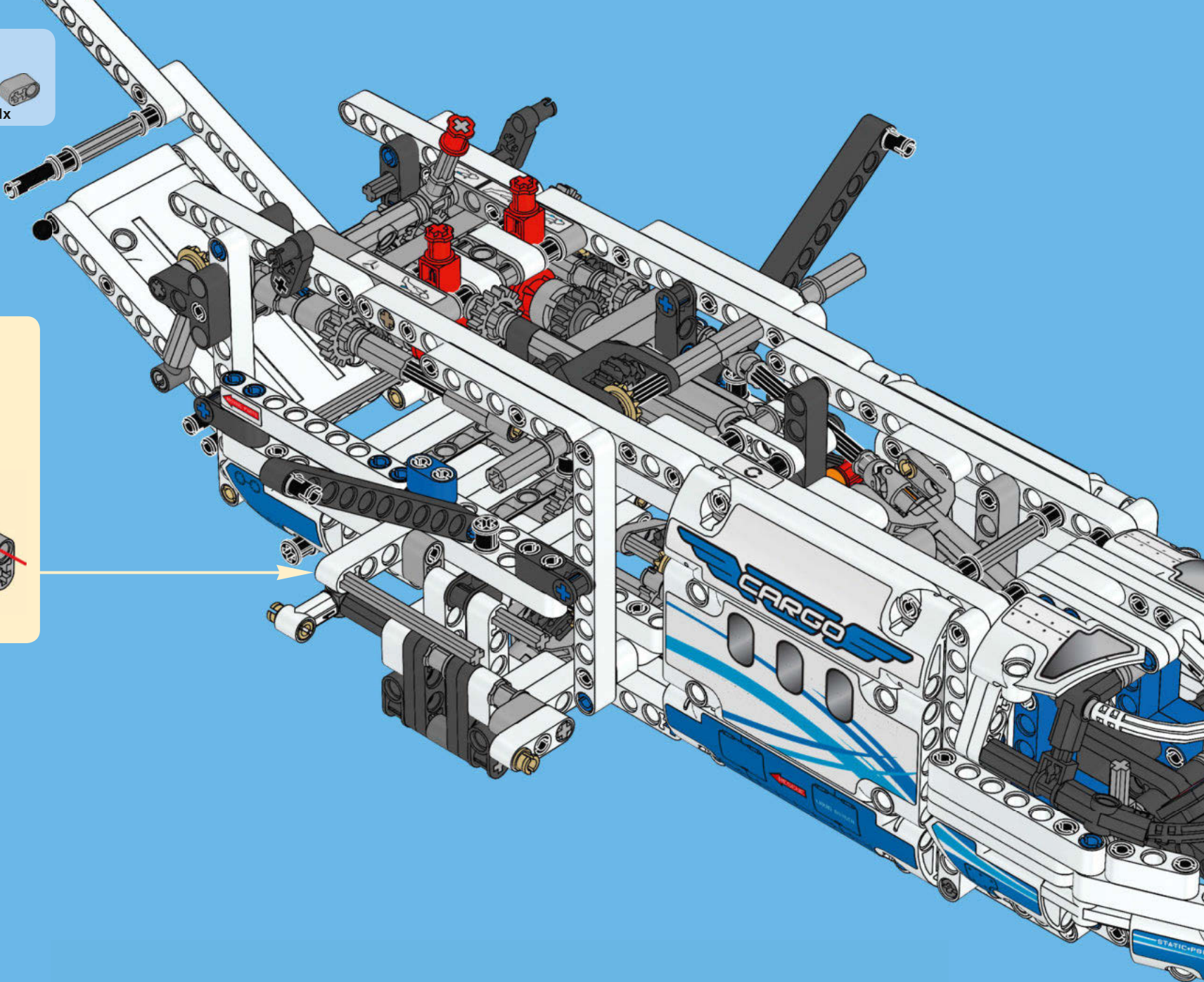
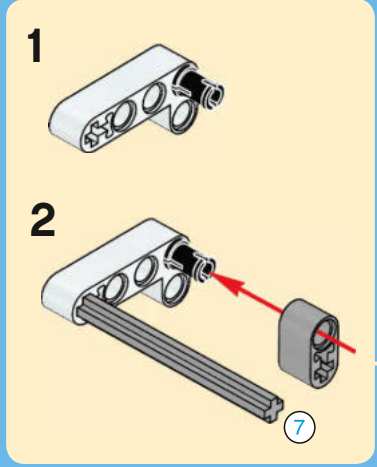

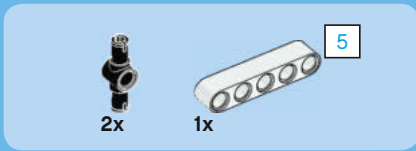

59

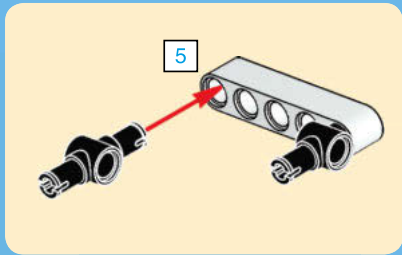
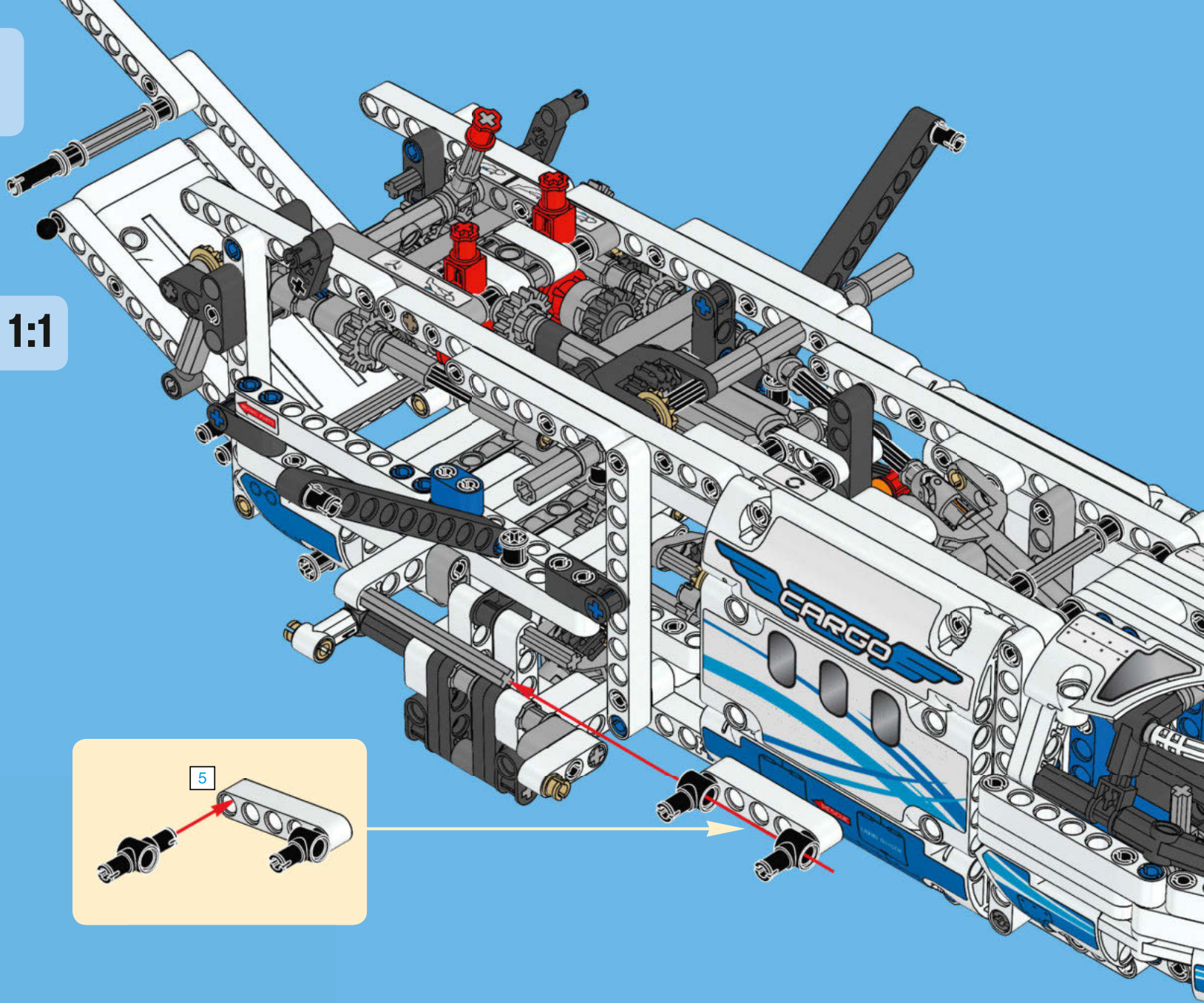
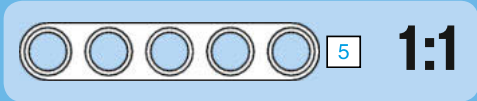

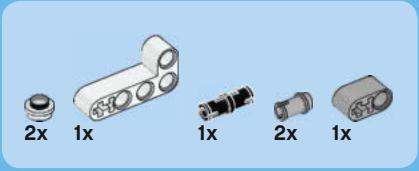

60

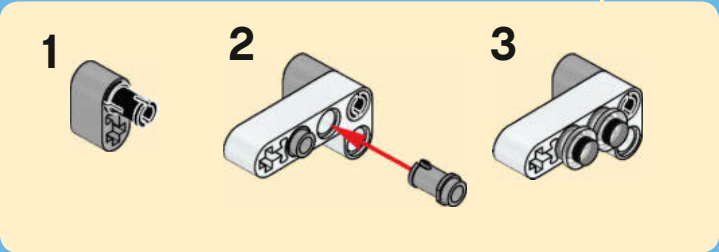
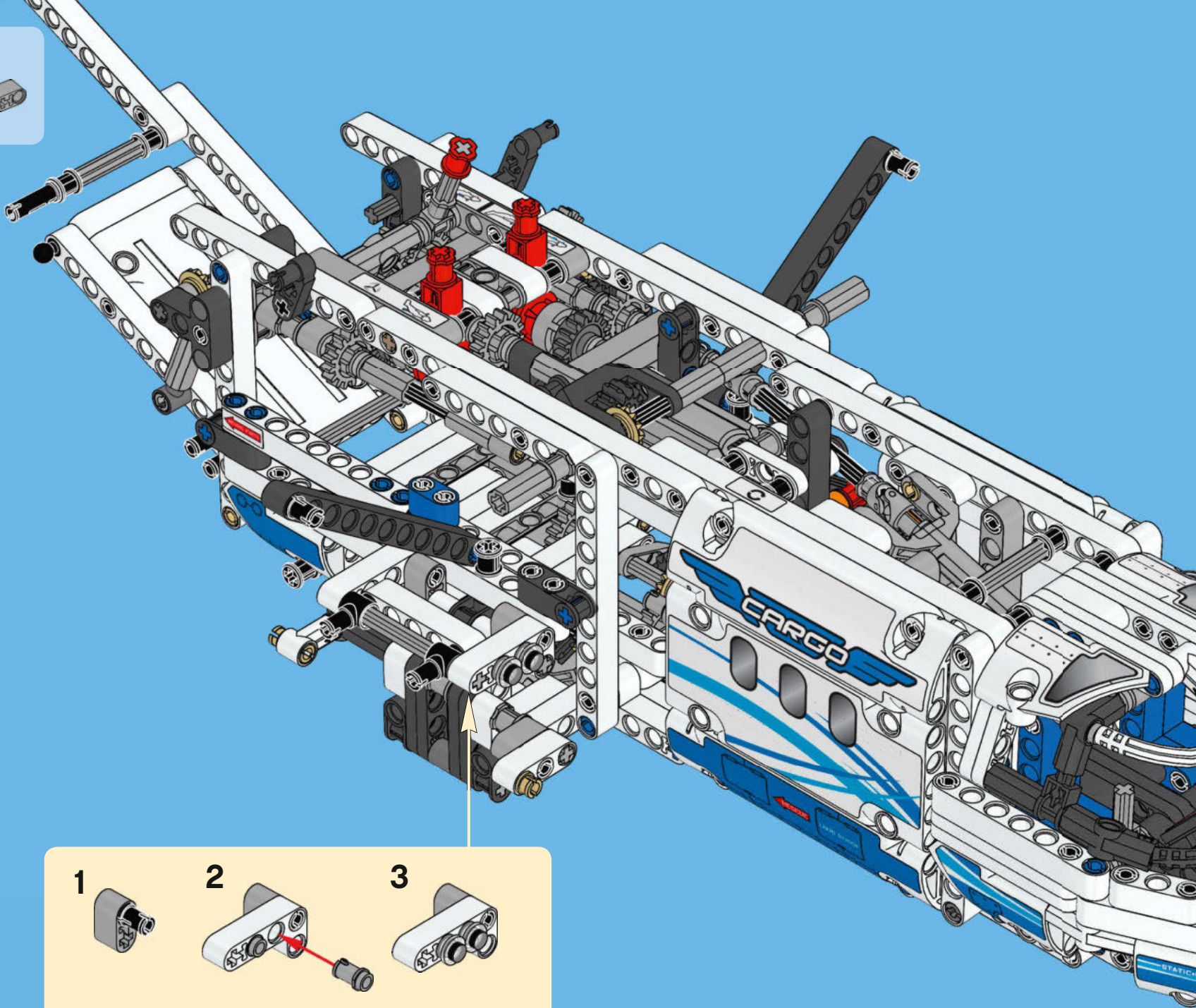

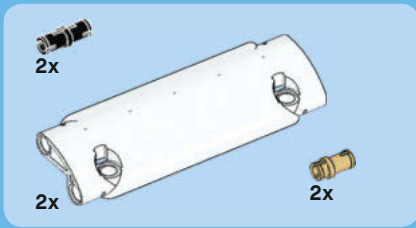

61

1

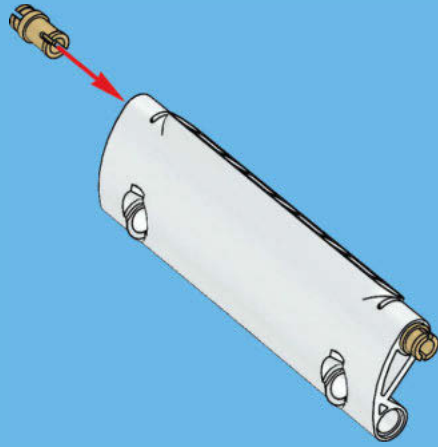

2

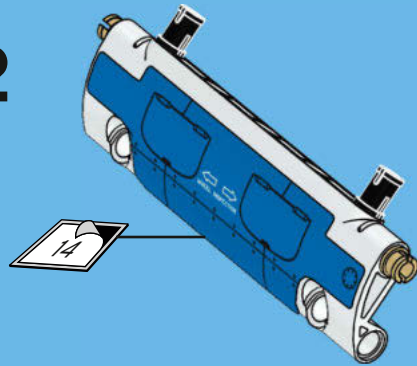

3

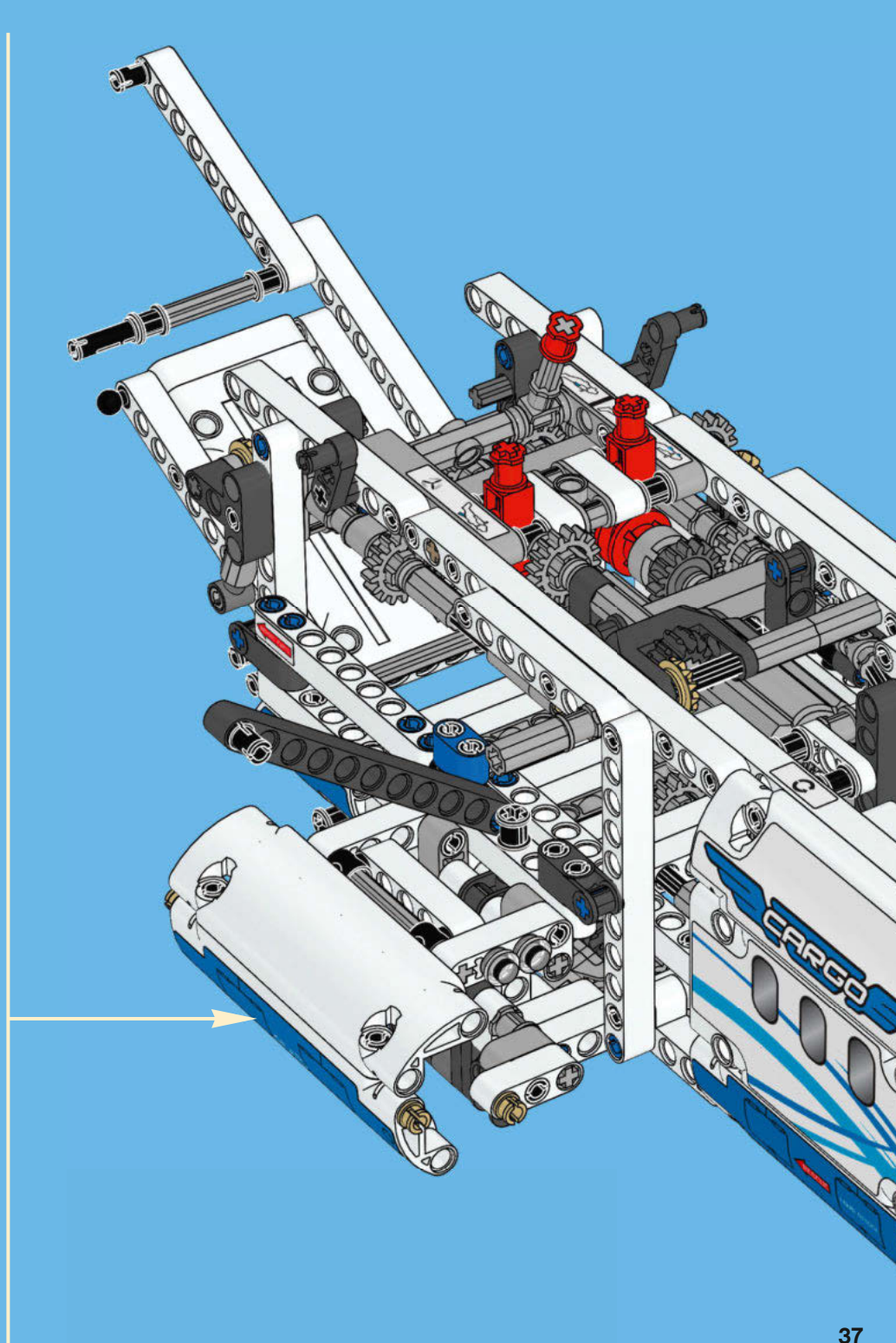
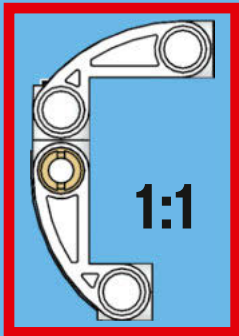
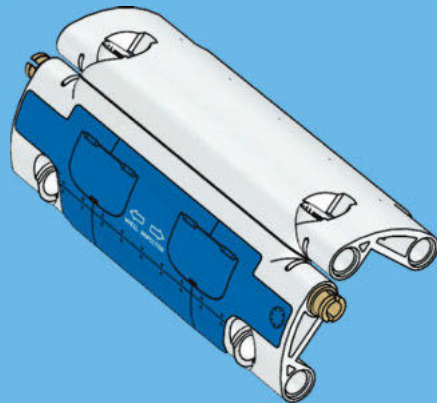



62

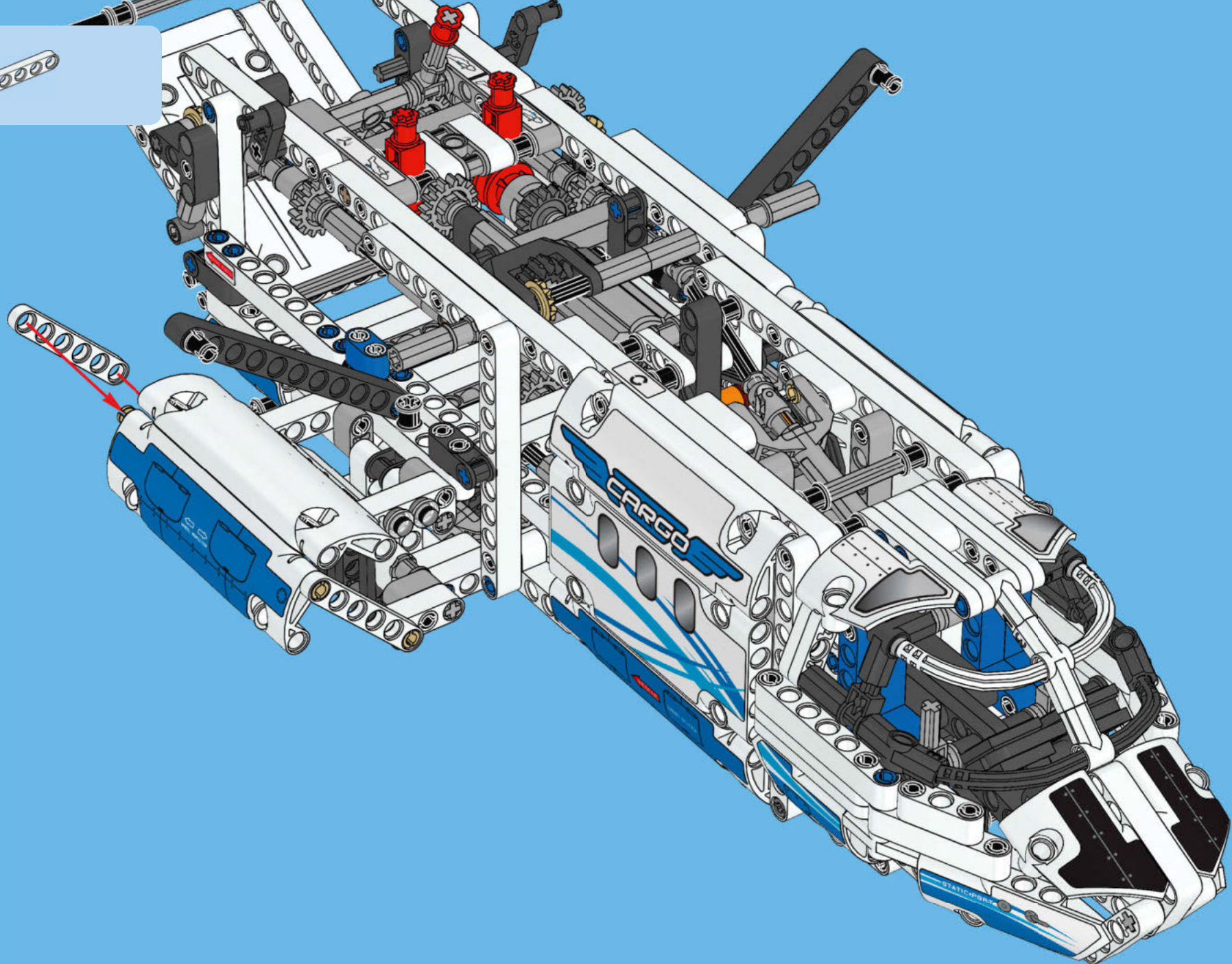

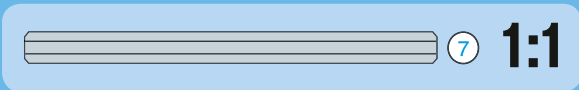
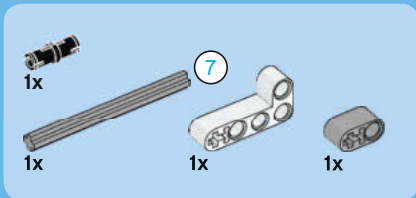

63

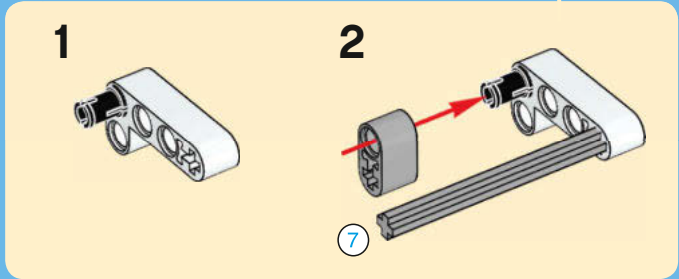
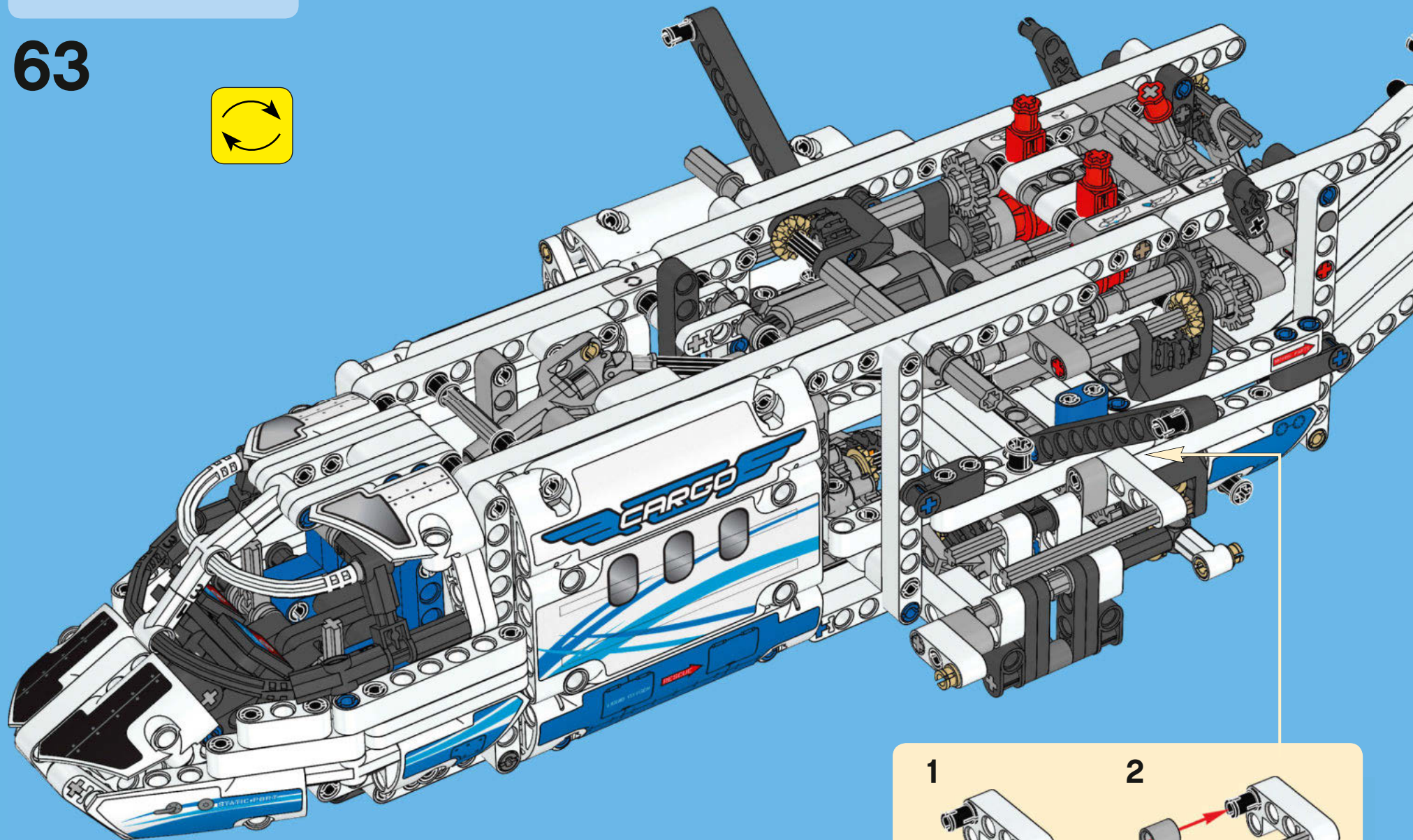
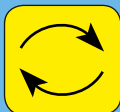



2x



1x

5



5

1:1

# 64

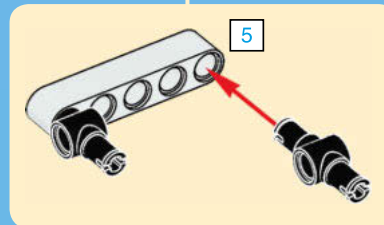
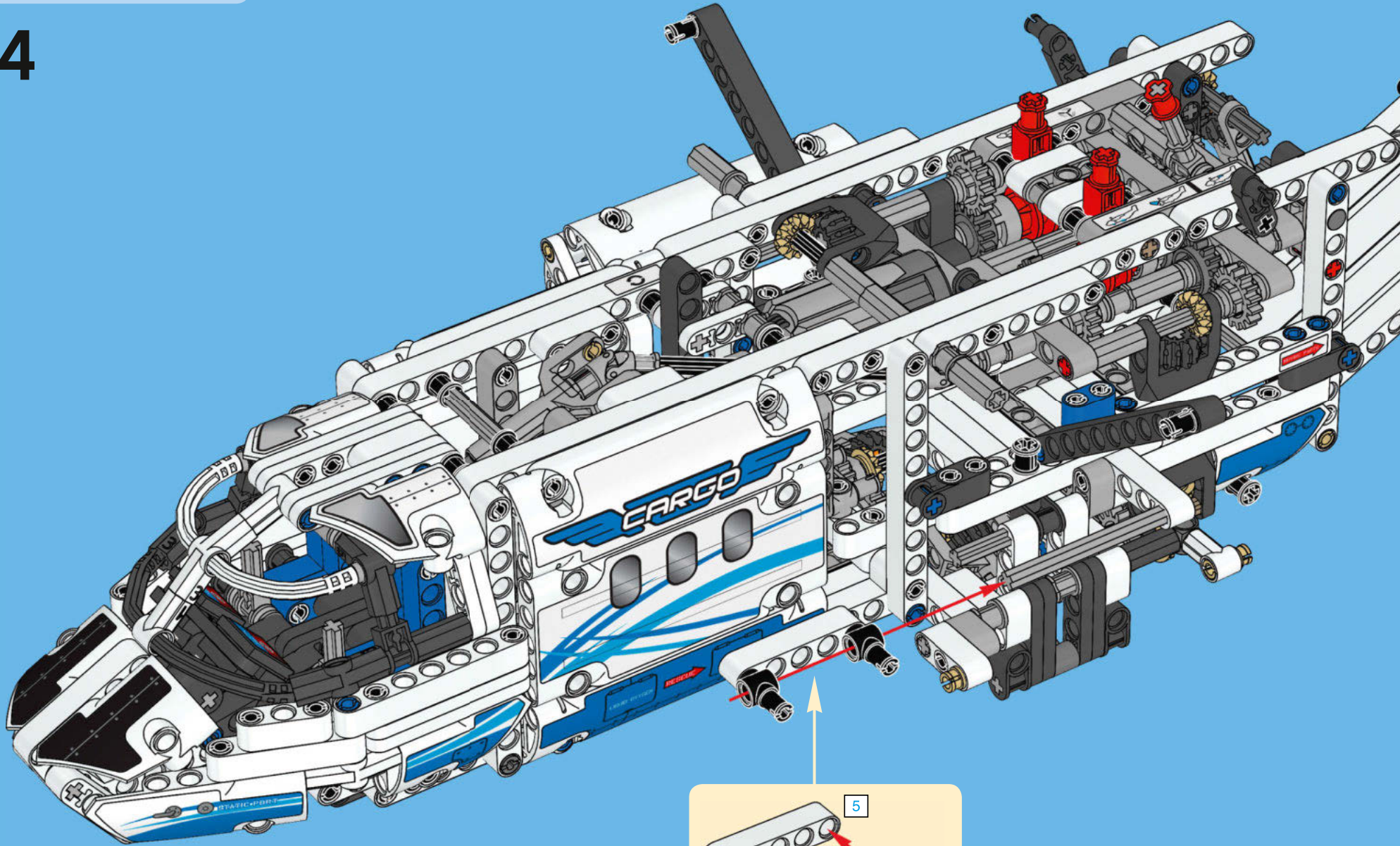

5



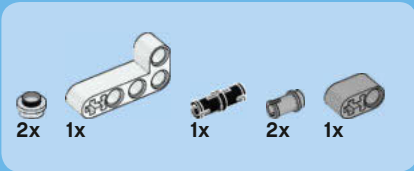

# 65

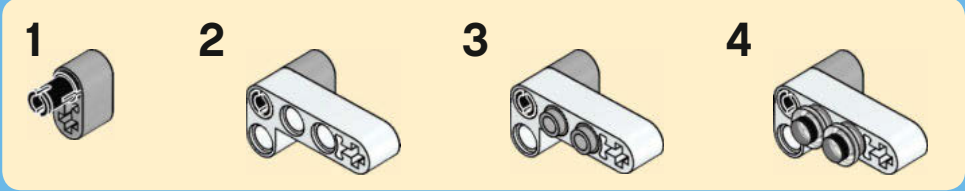
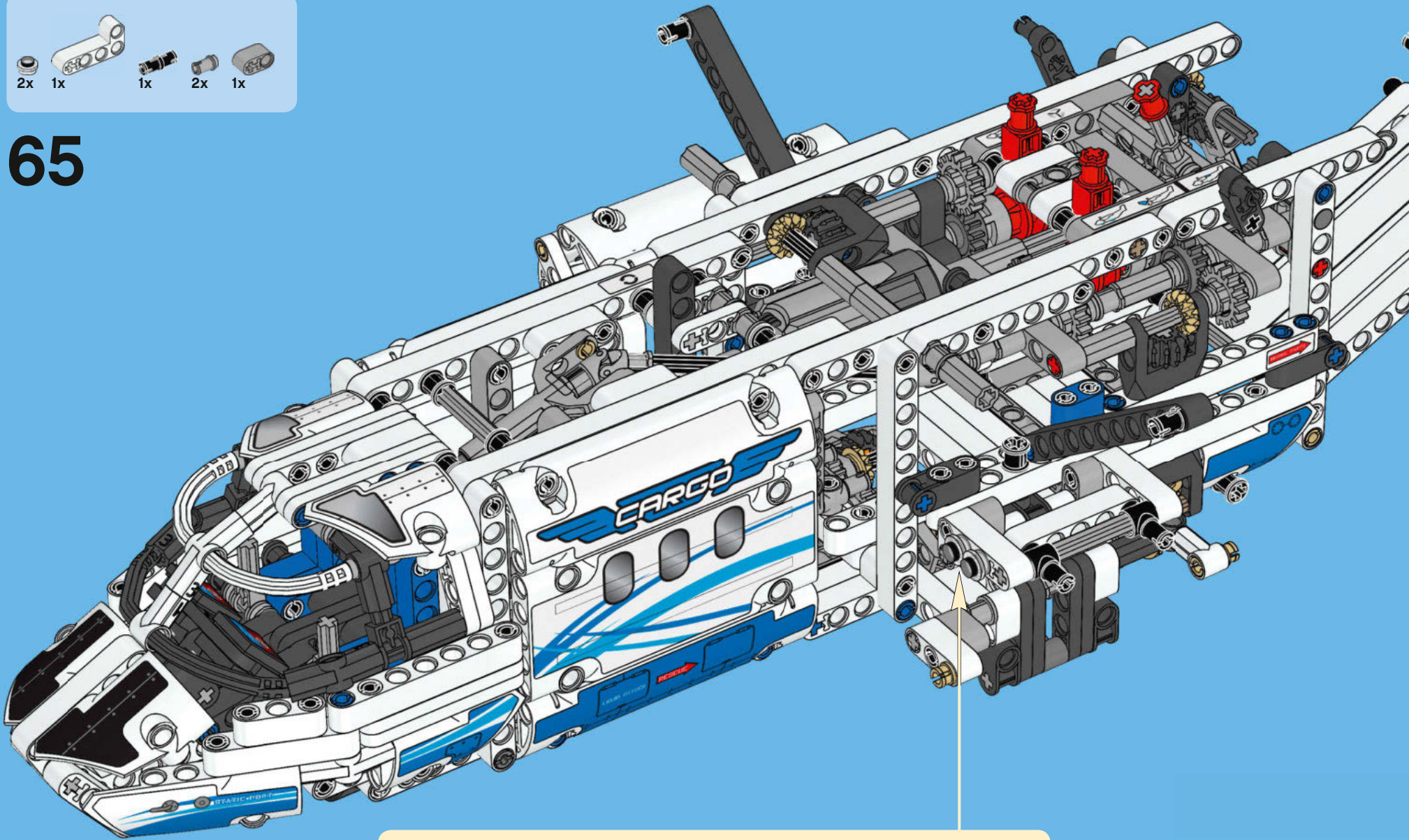

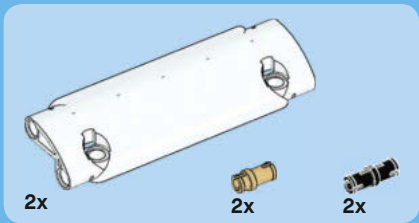

# 66

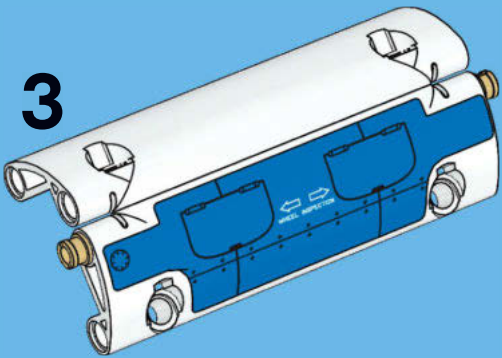
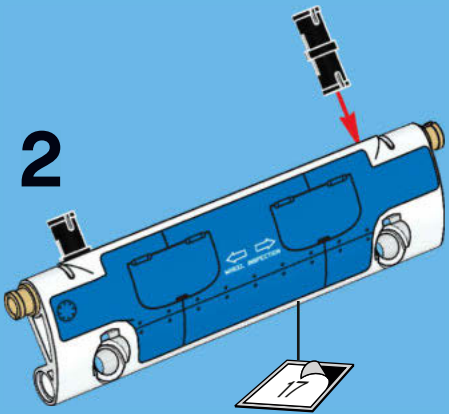
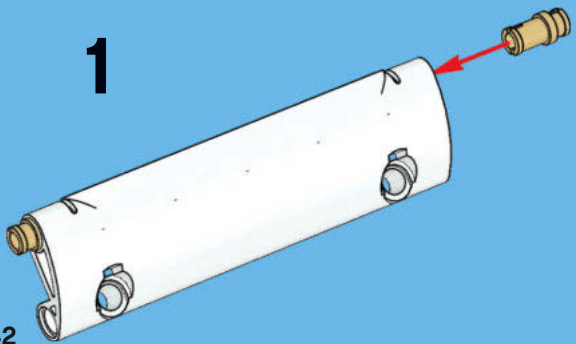
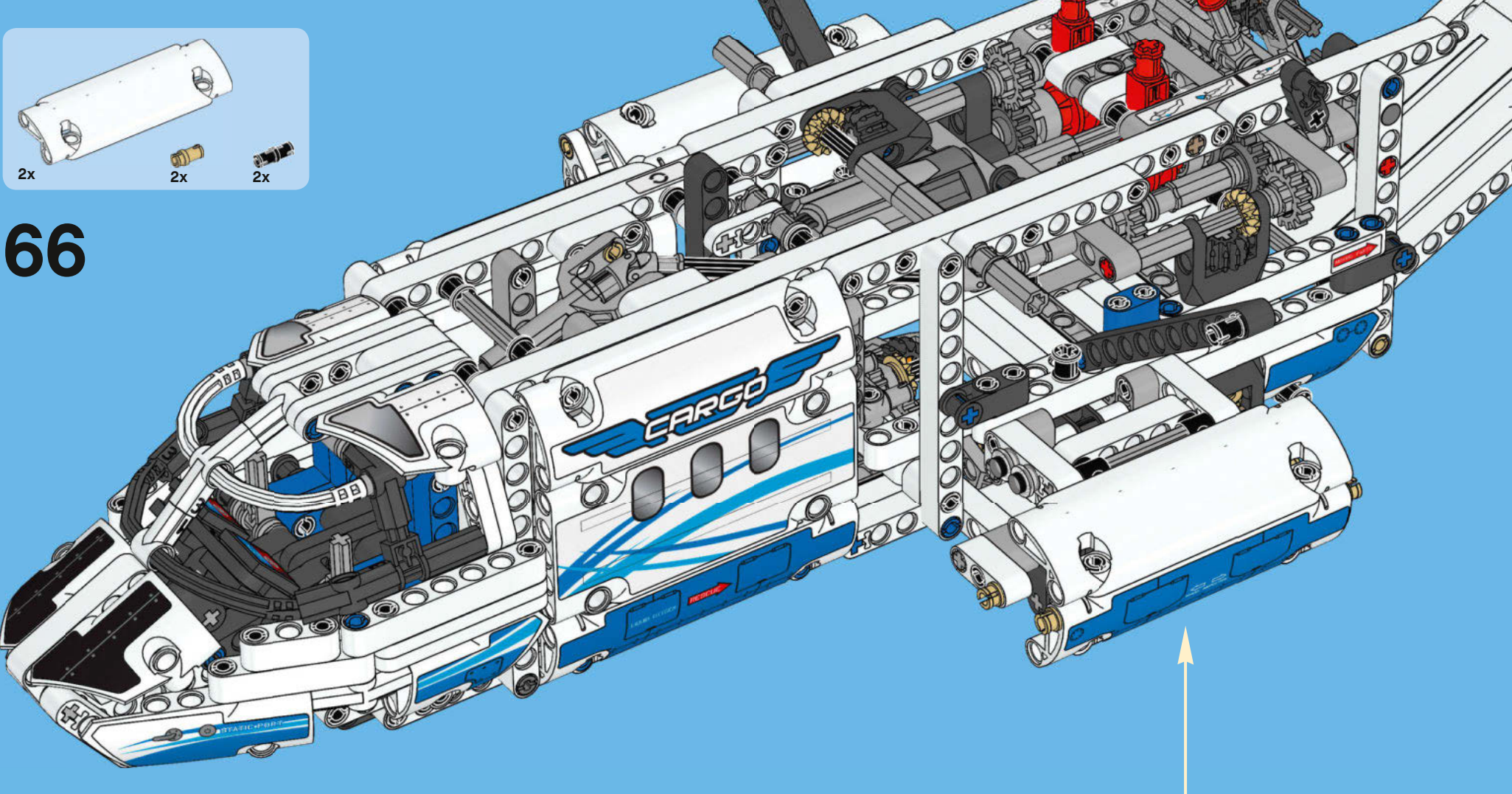



2x

67

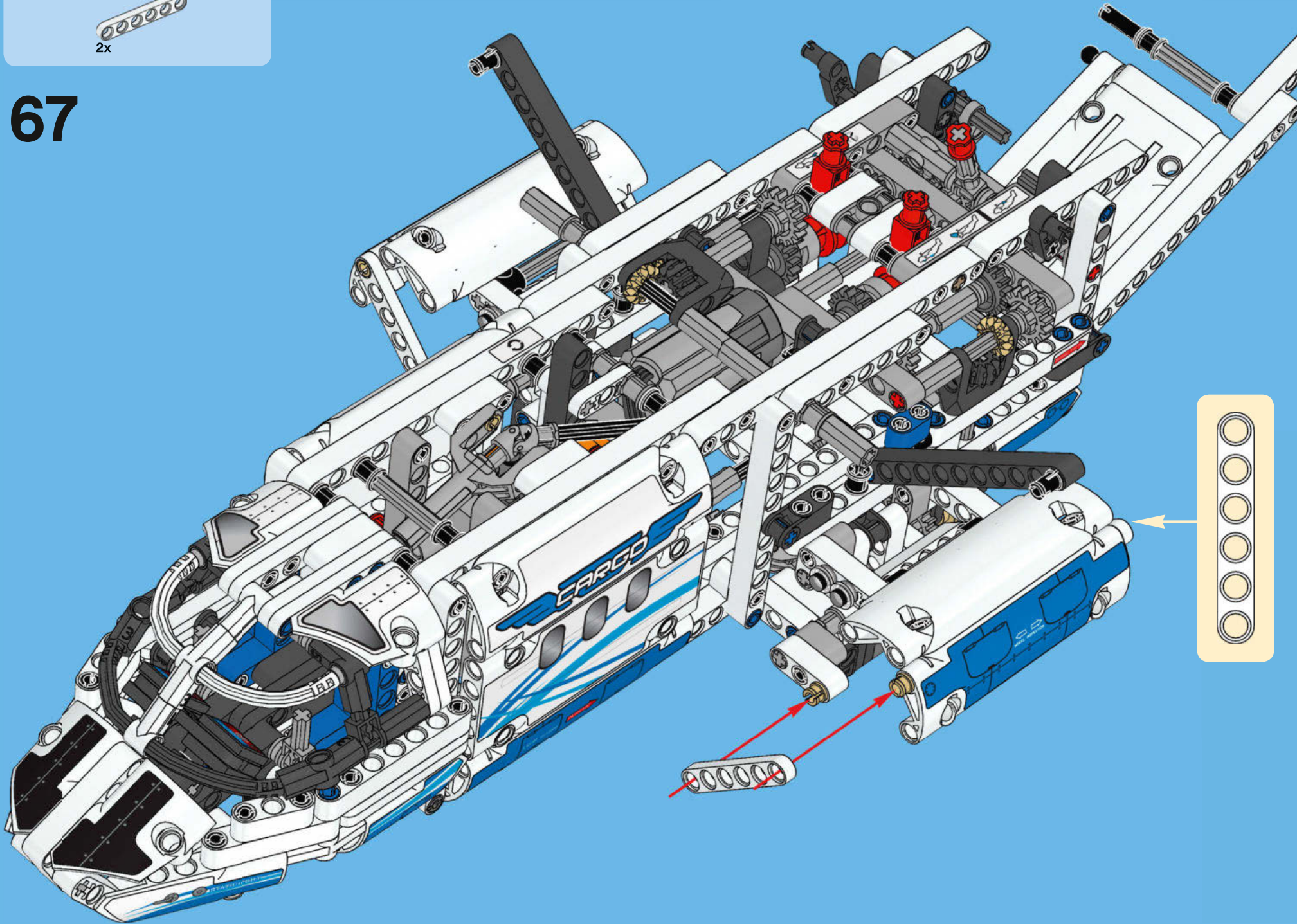

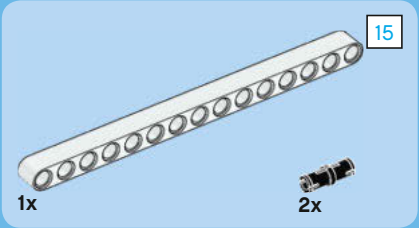
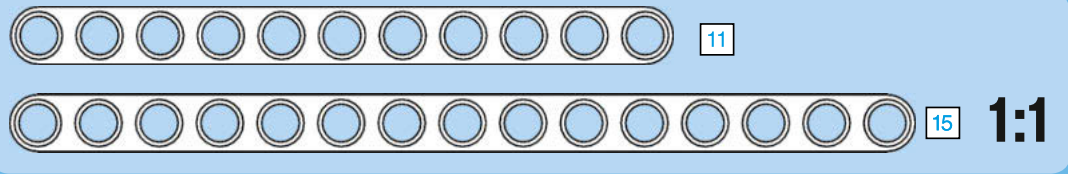
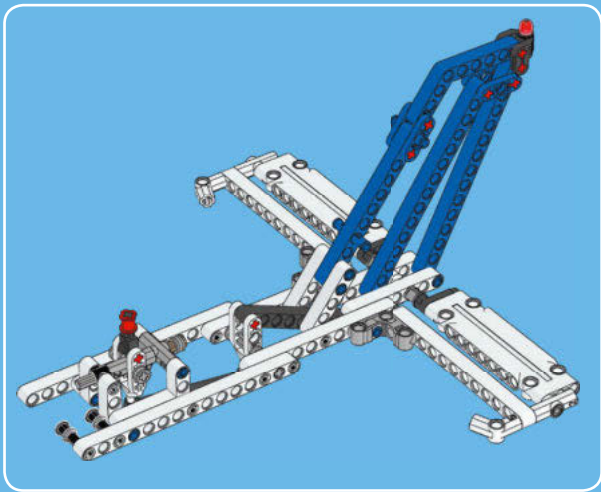

1

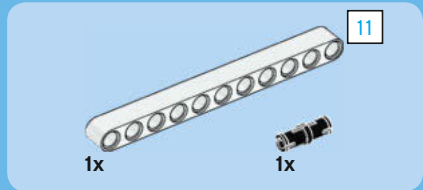
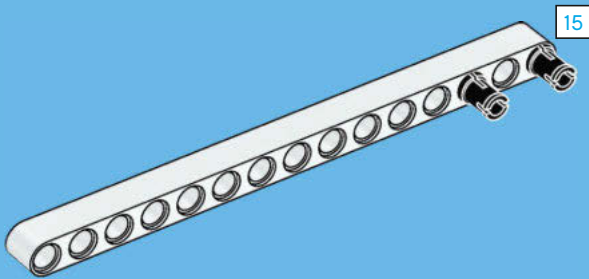

2

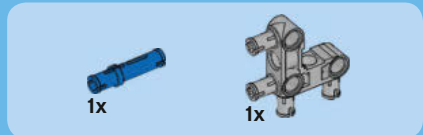
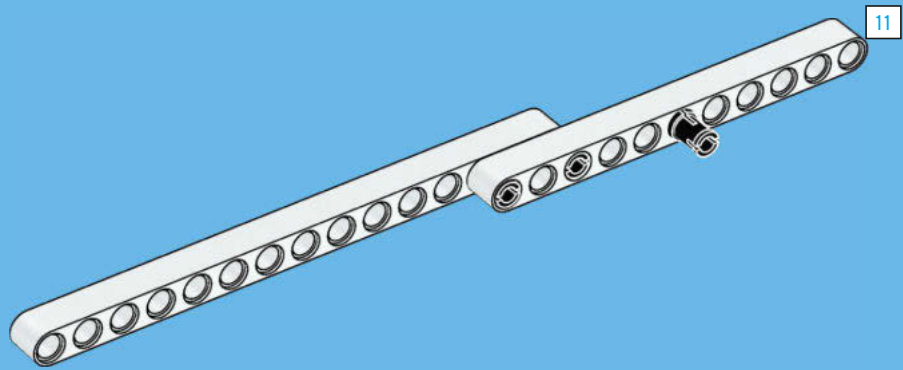

3

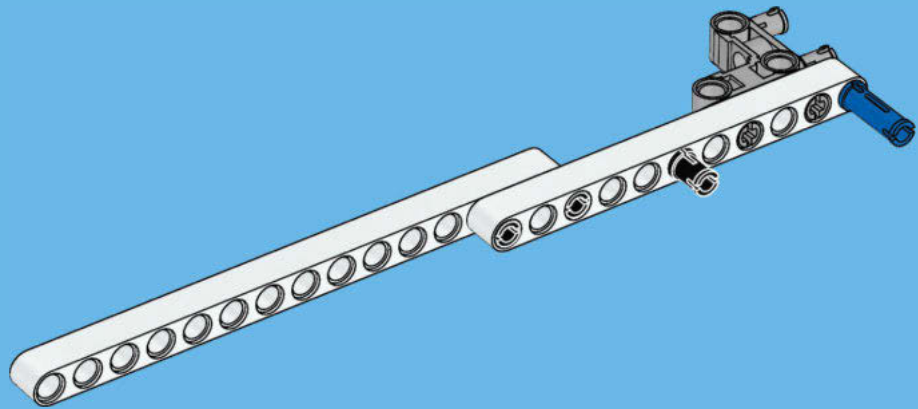

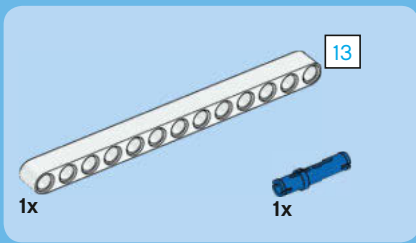

4

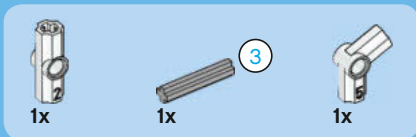
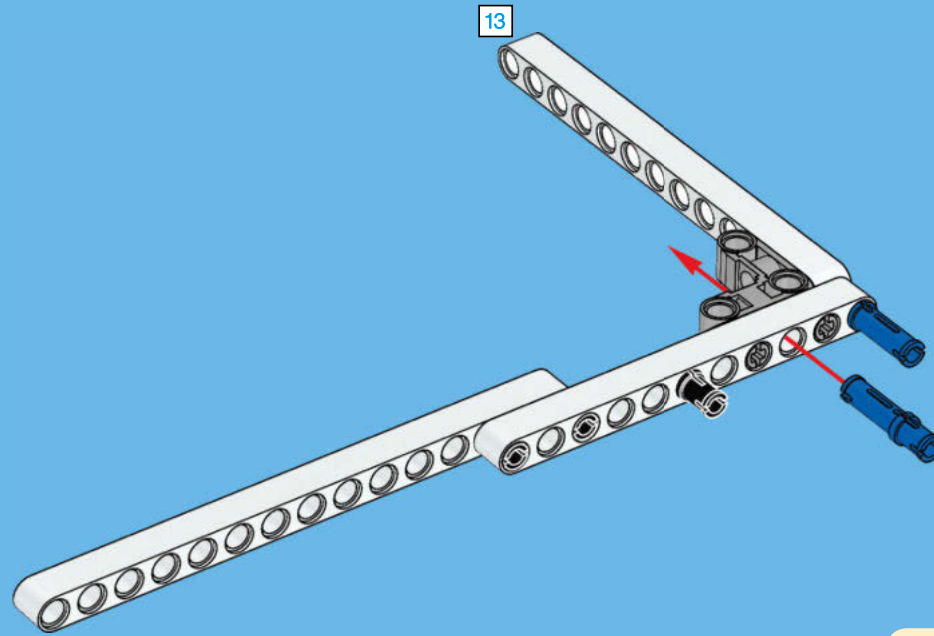
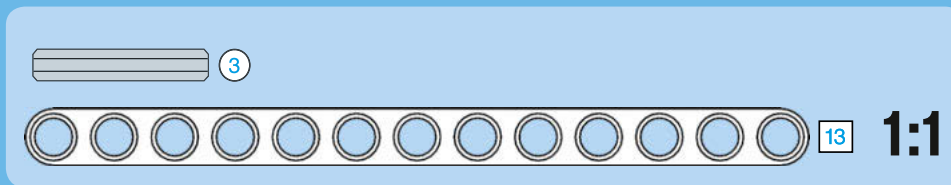

5

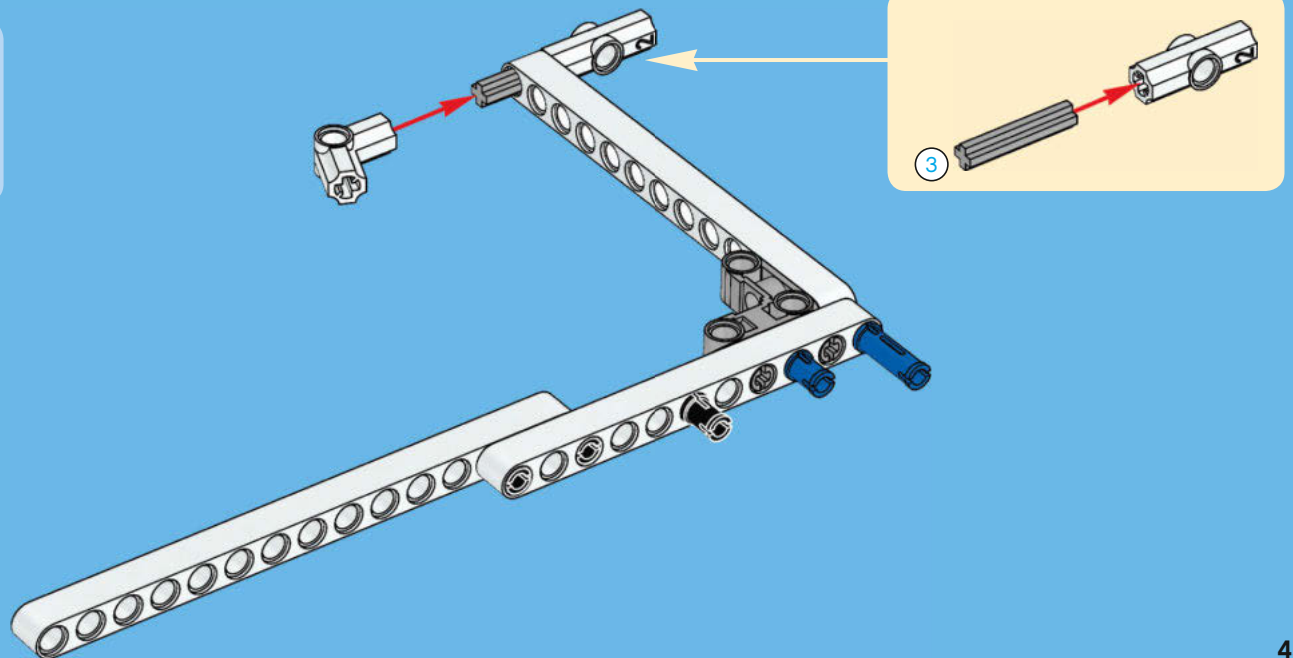

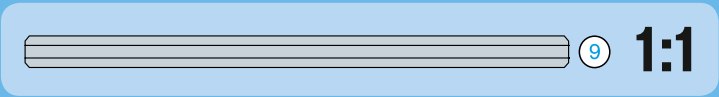
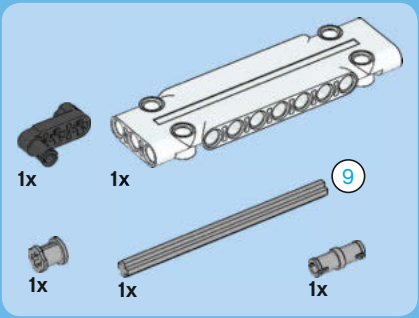

6

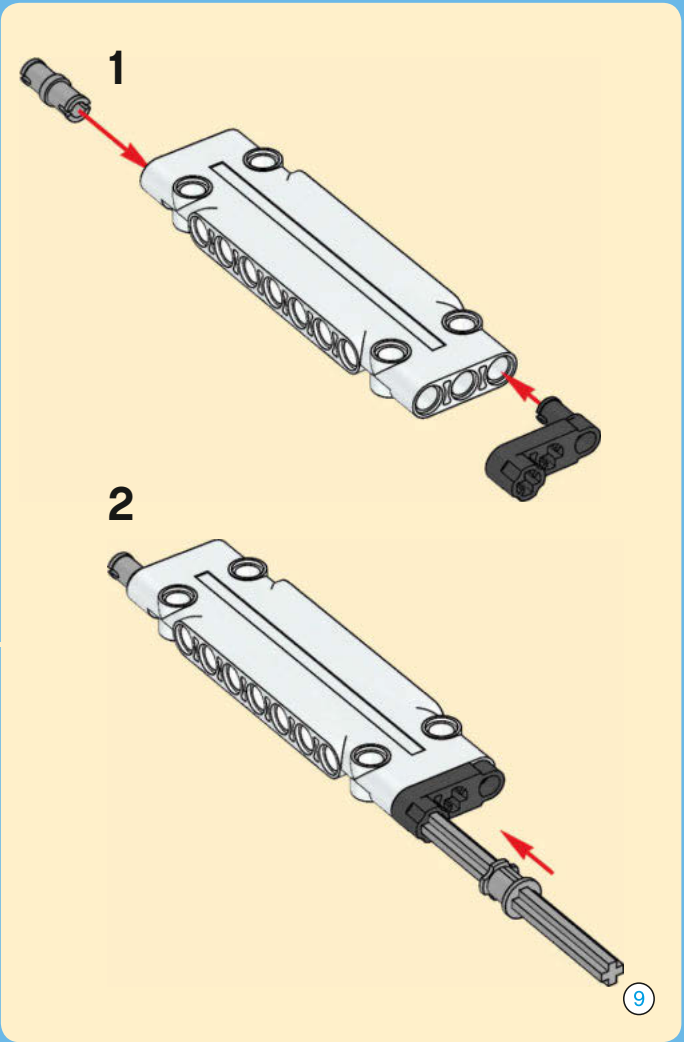
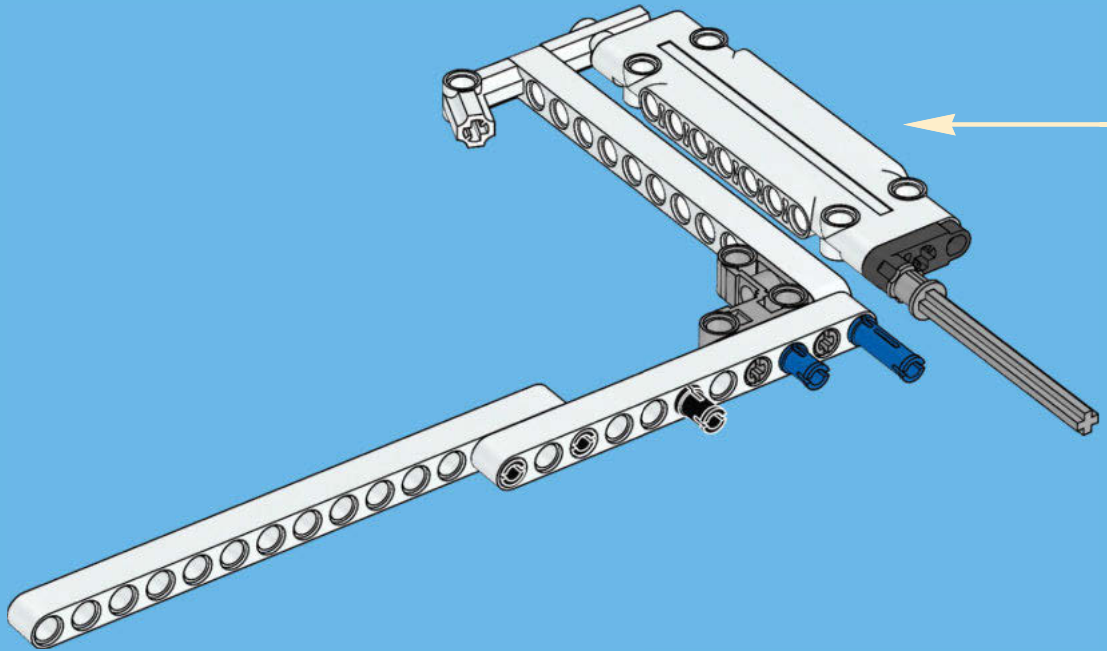

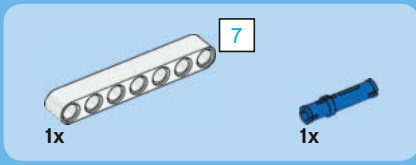

7

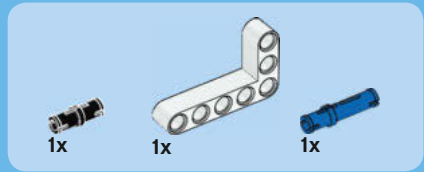
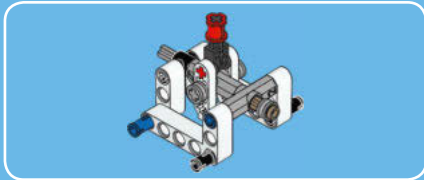
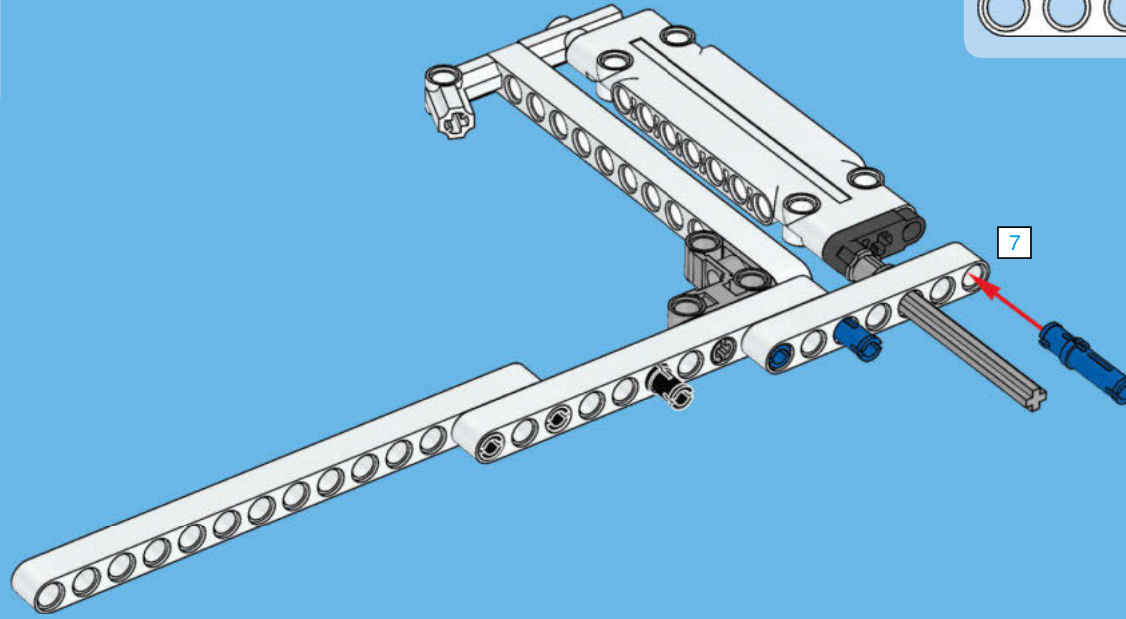
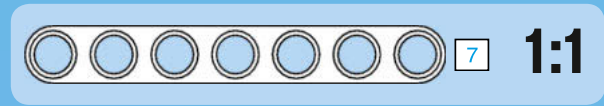

1

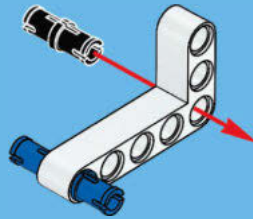

2

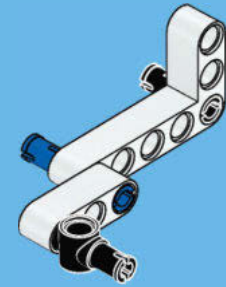

3

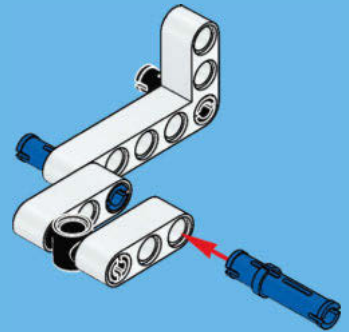

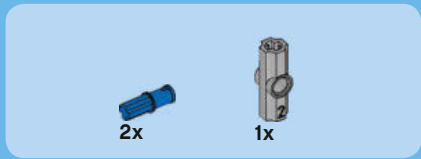

4

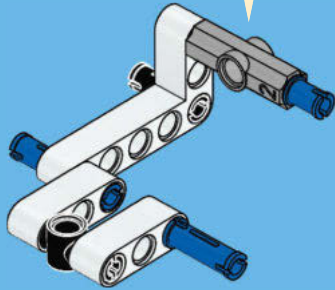
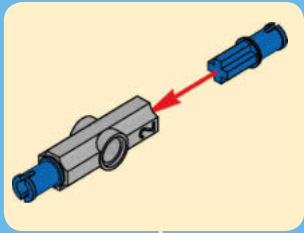

5

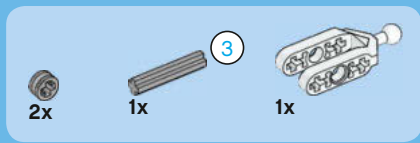
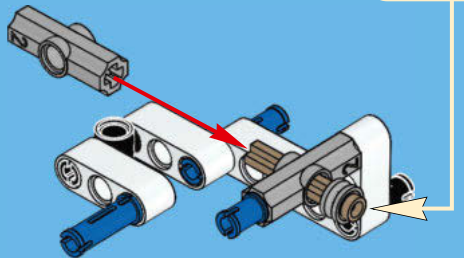
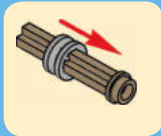

6

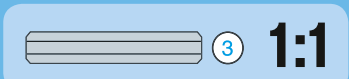
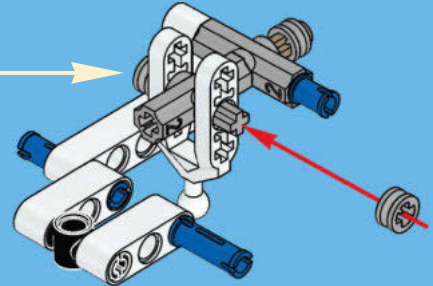
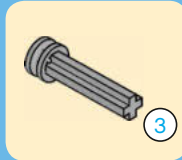

7

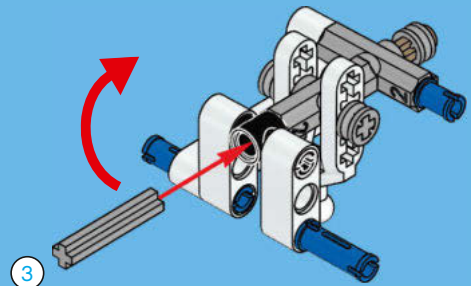
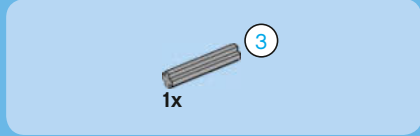



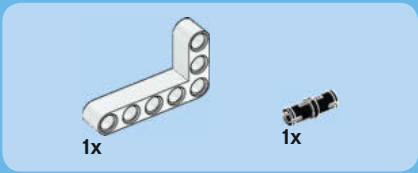

8

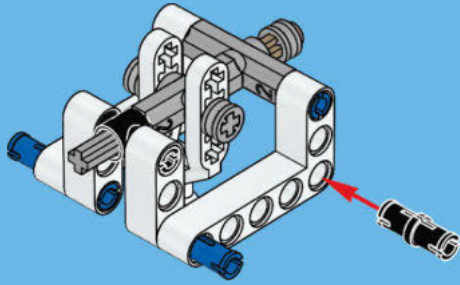

9

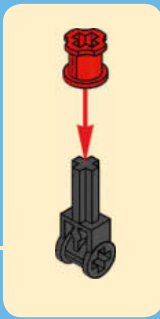
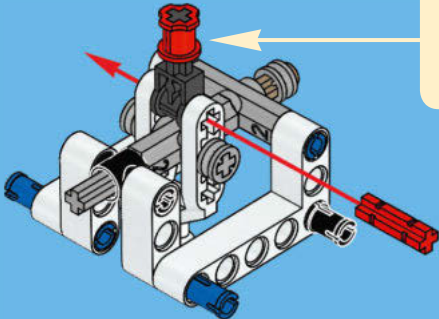

10

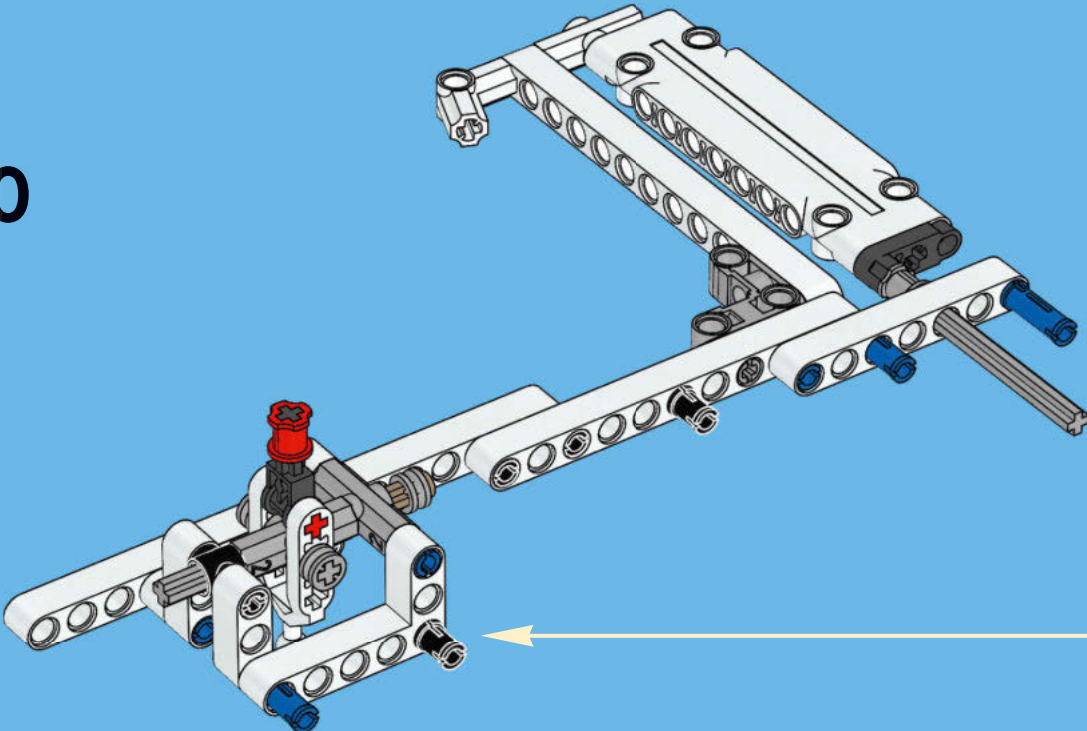

11

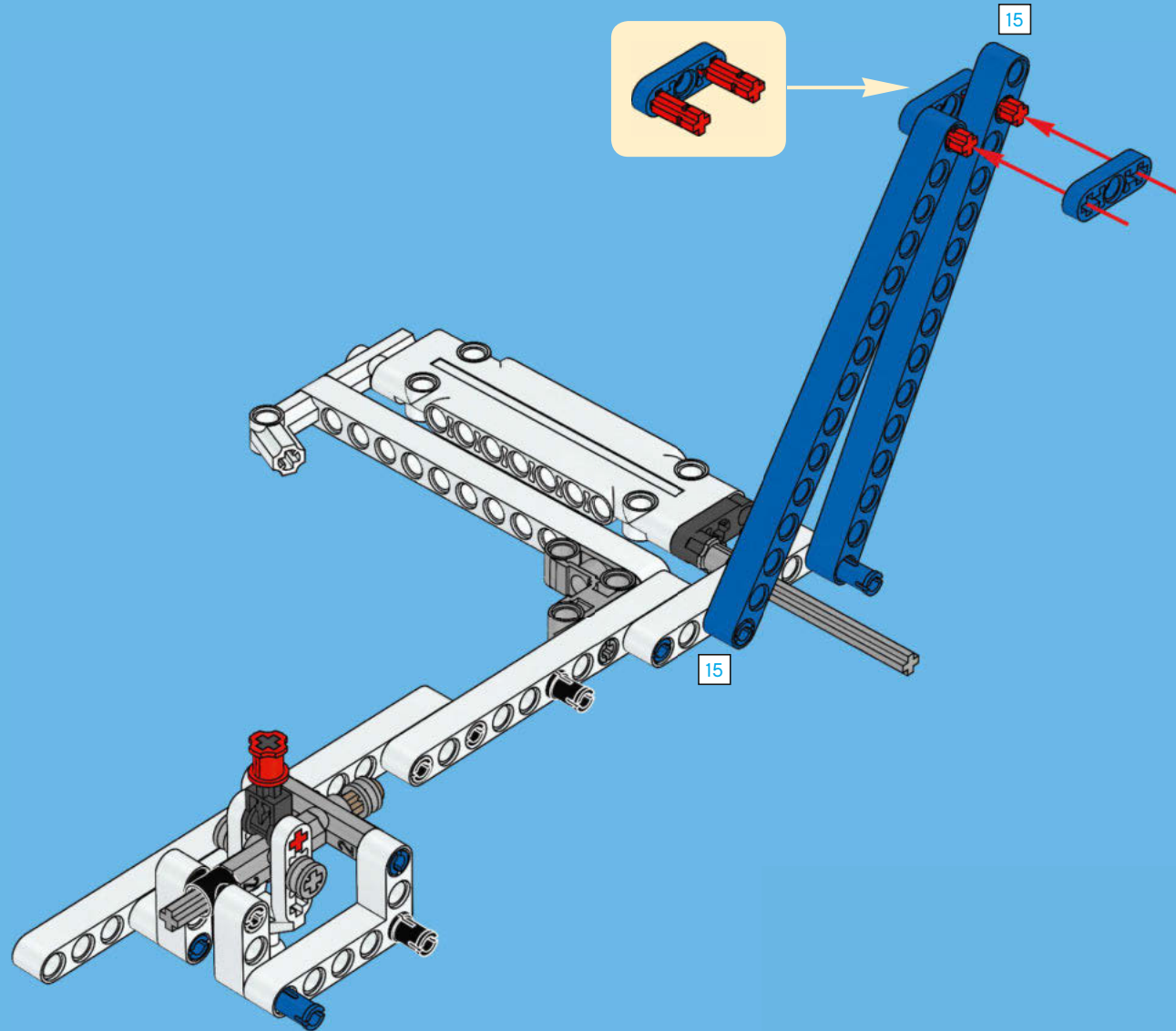
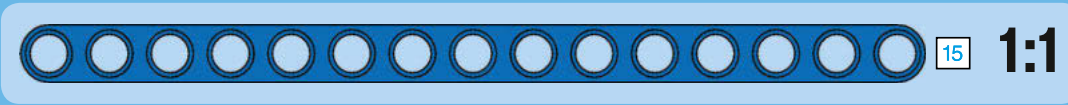
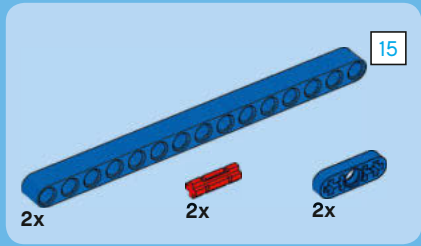

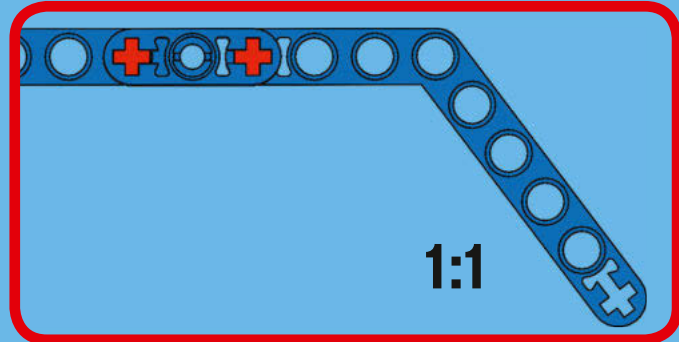
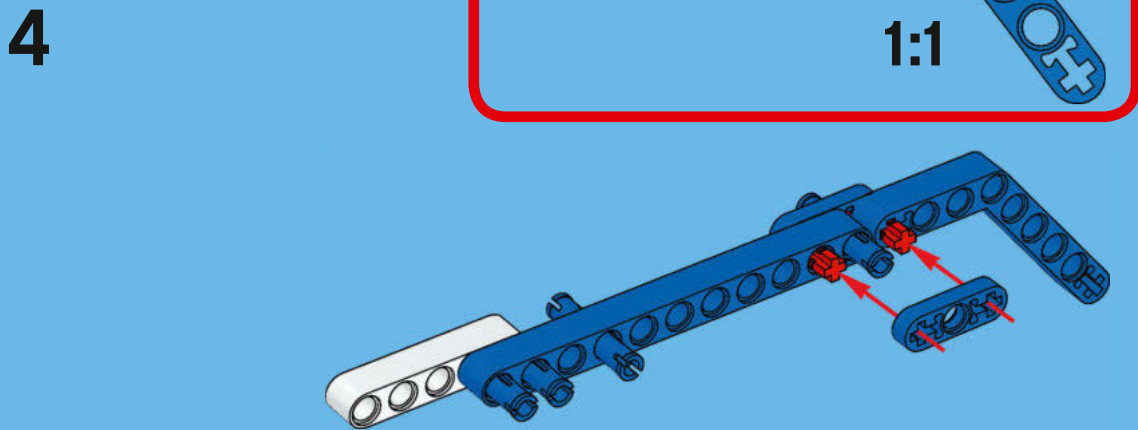
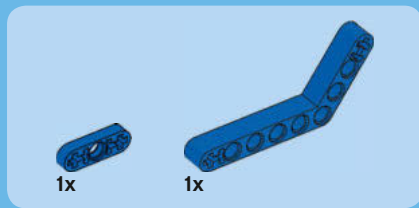
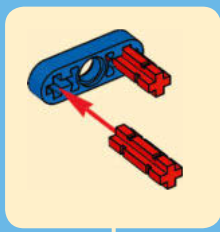
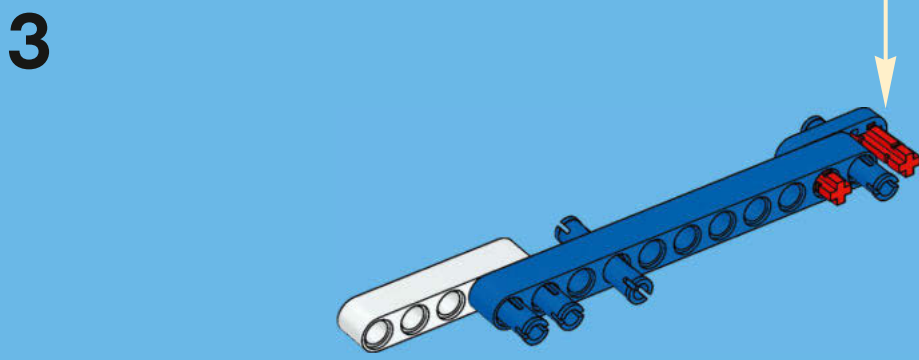
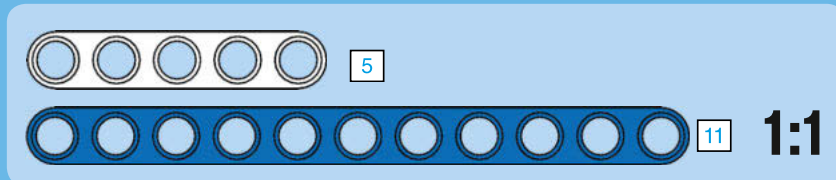
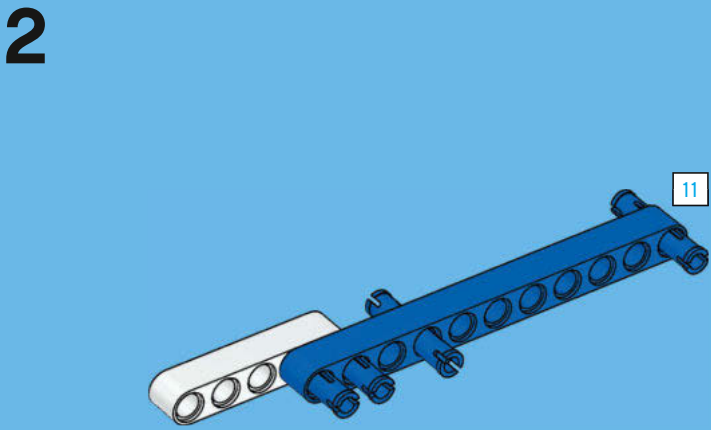
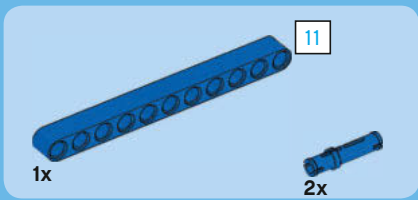
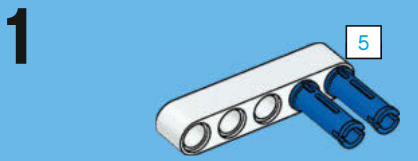
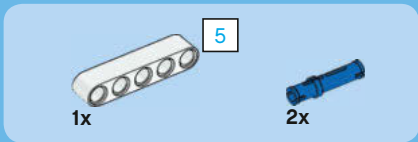
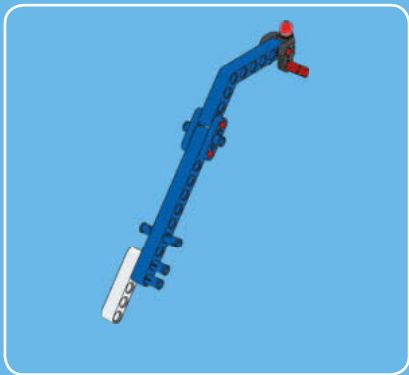



5

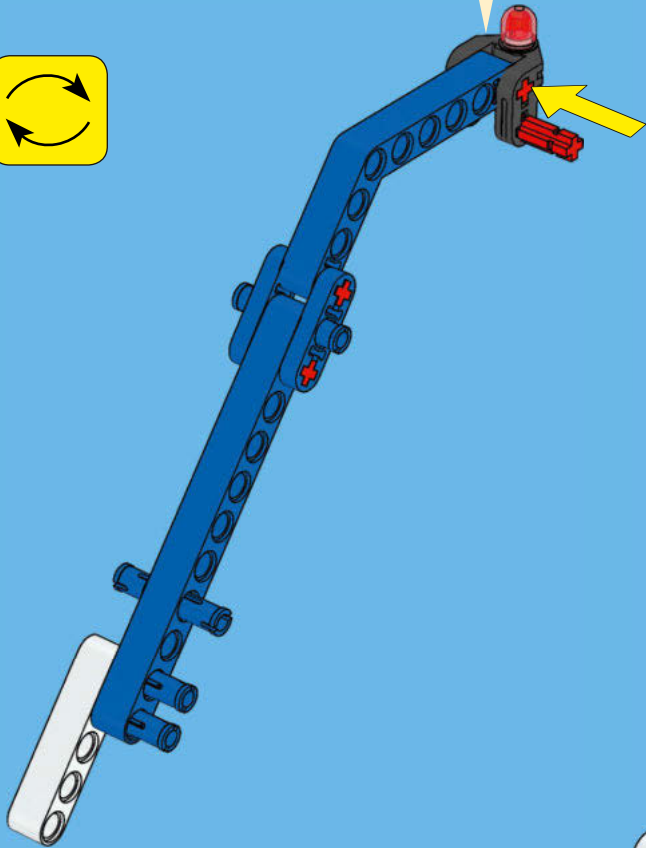
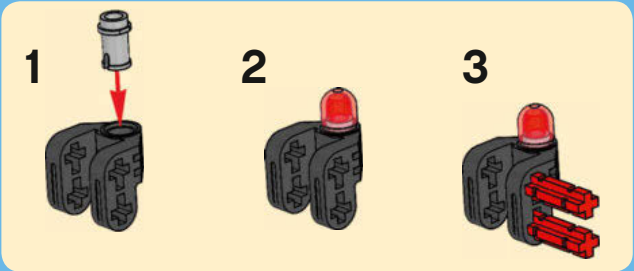

12

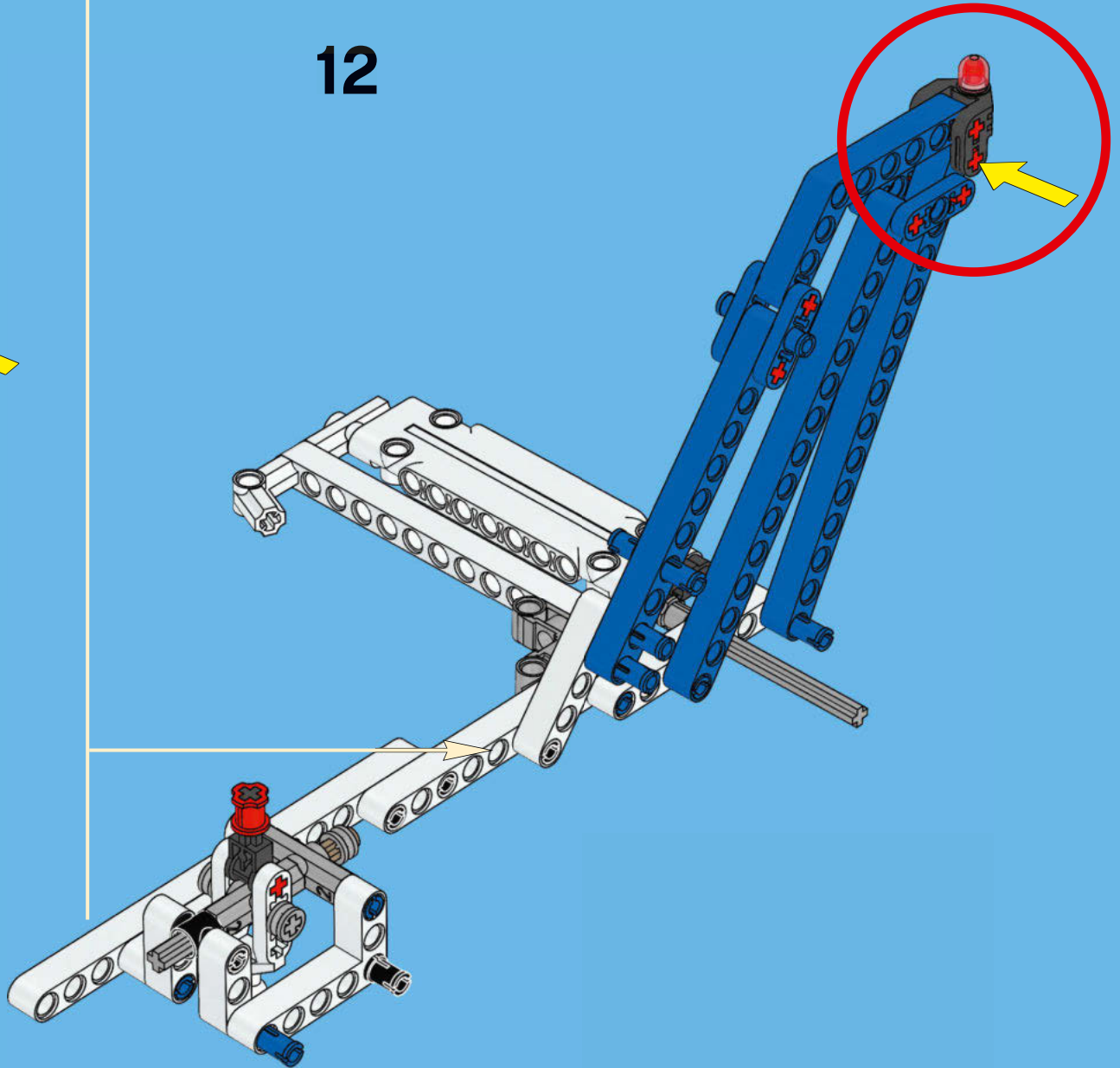

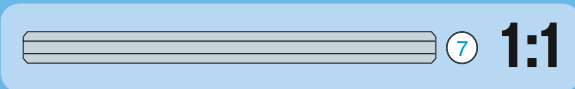
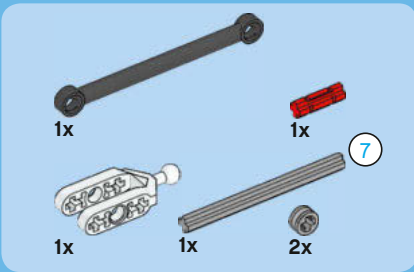

13

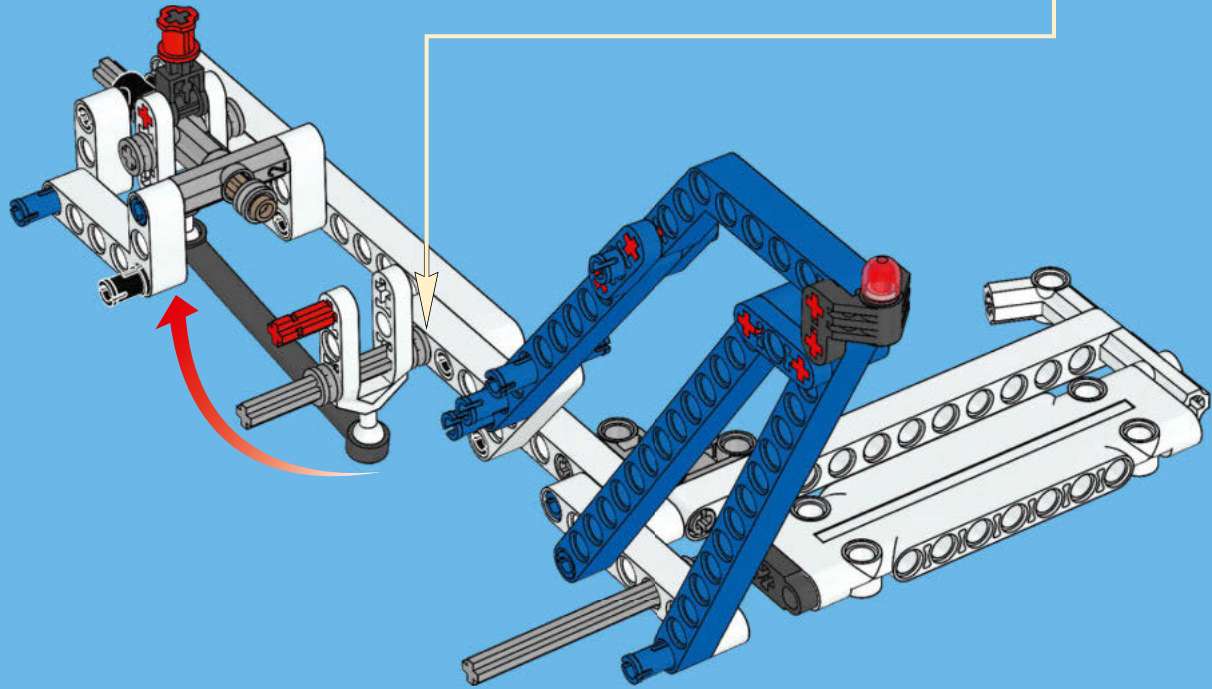
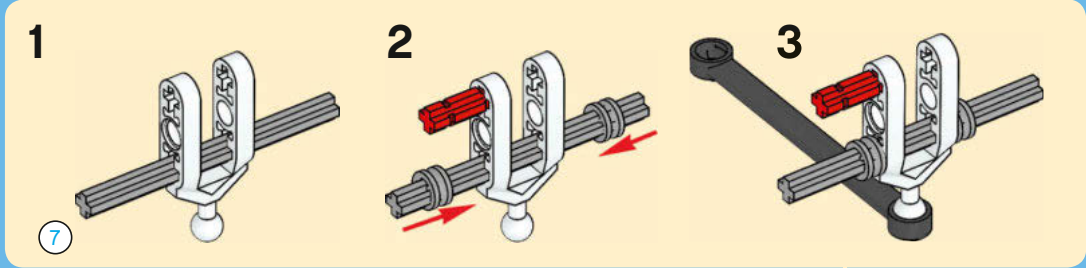

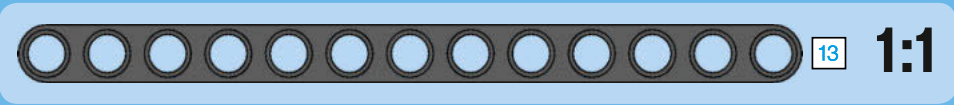
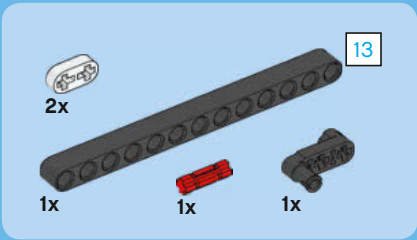

# 14

1

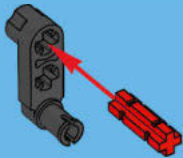

2

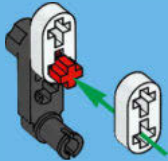

3

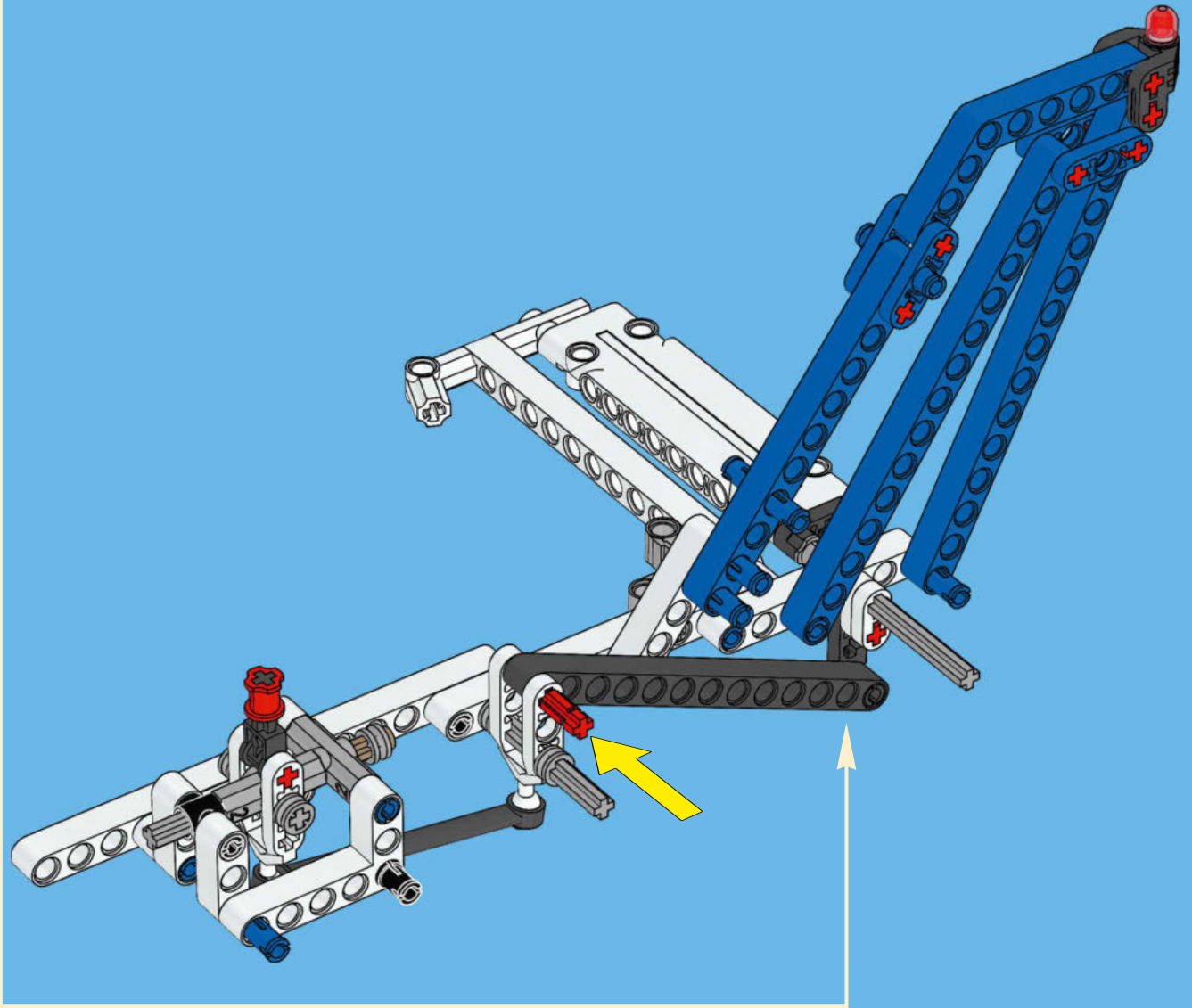
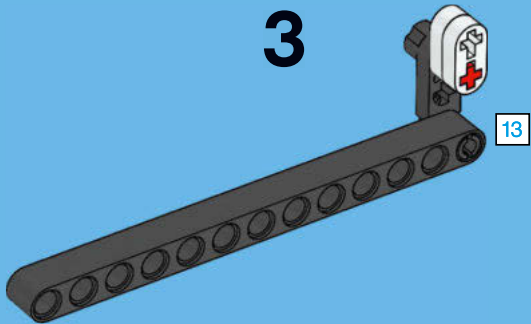

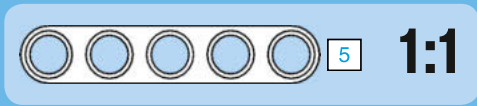
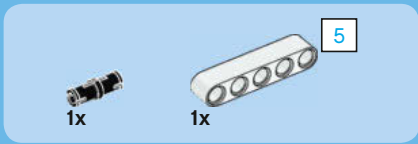

15

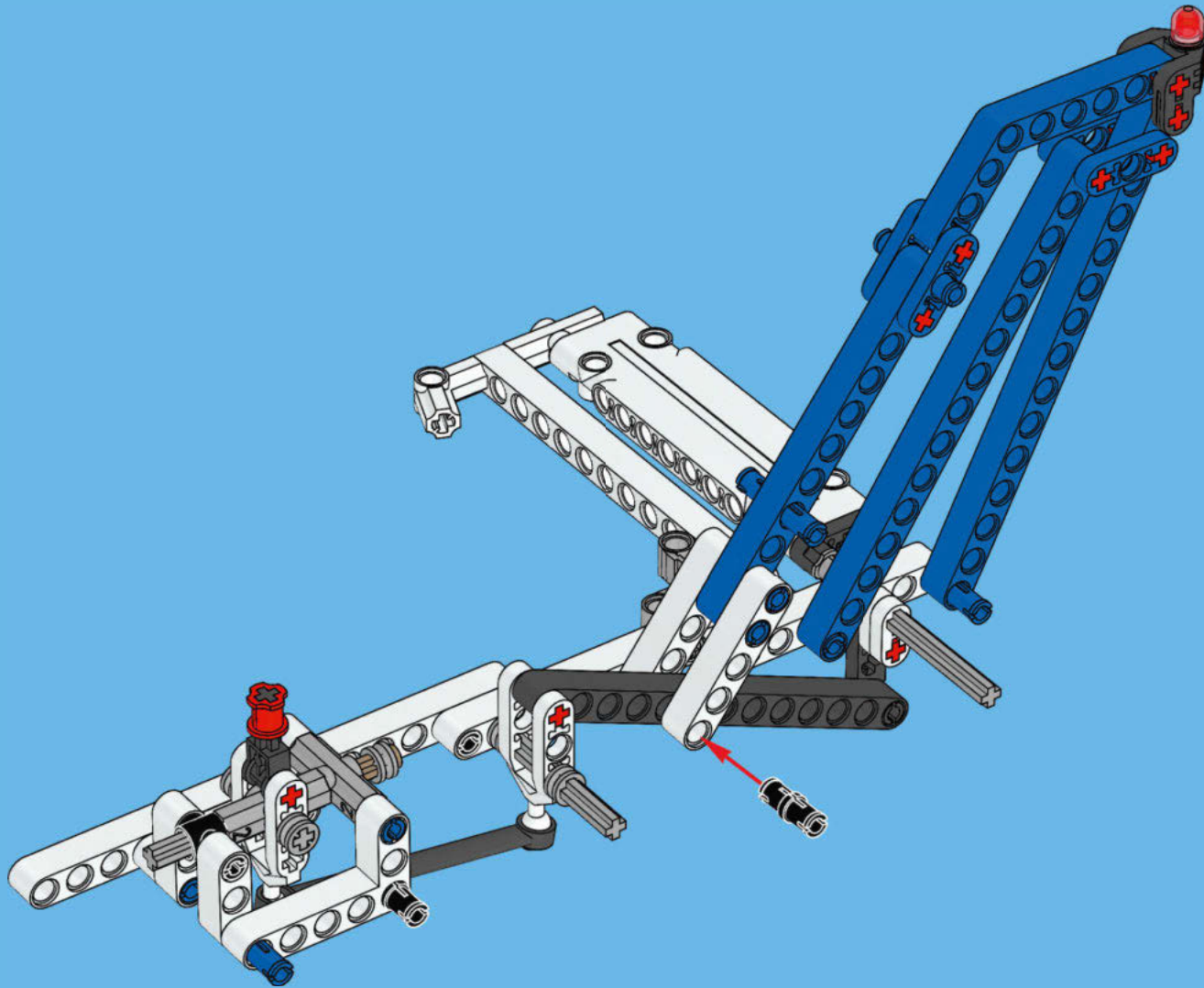

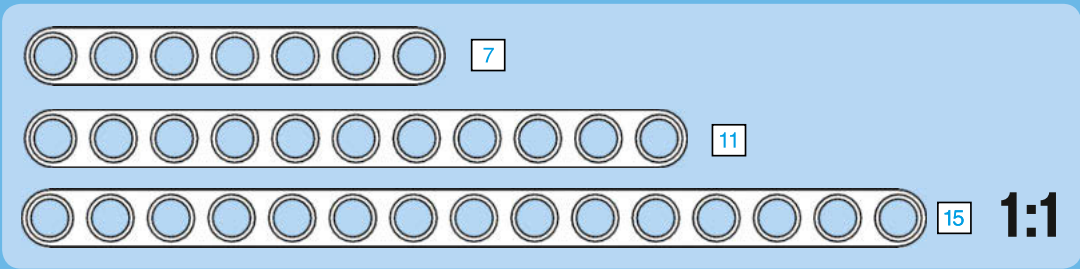
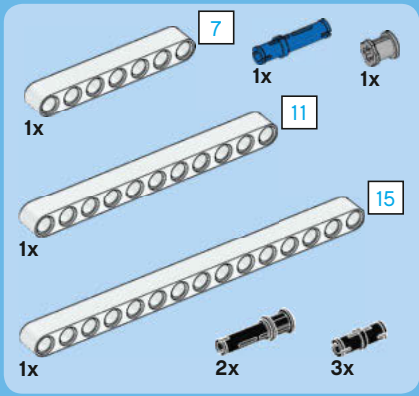

# 16

1

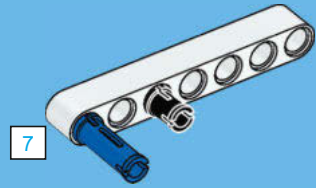

2

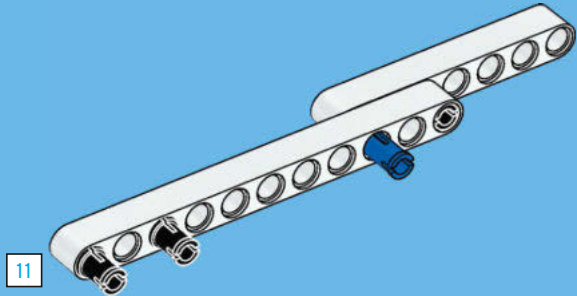

3

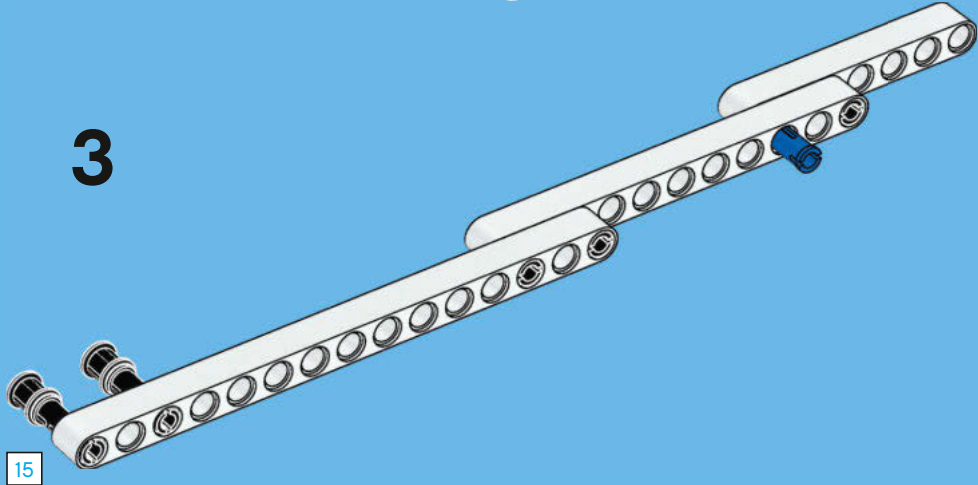



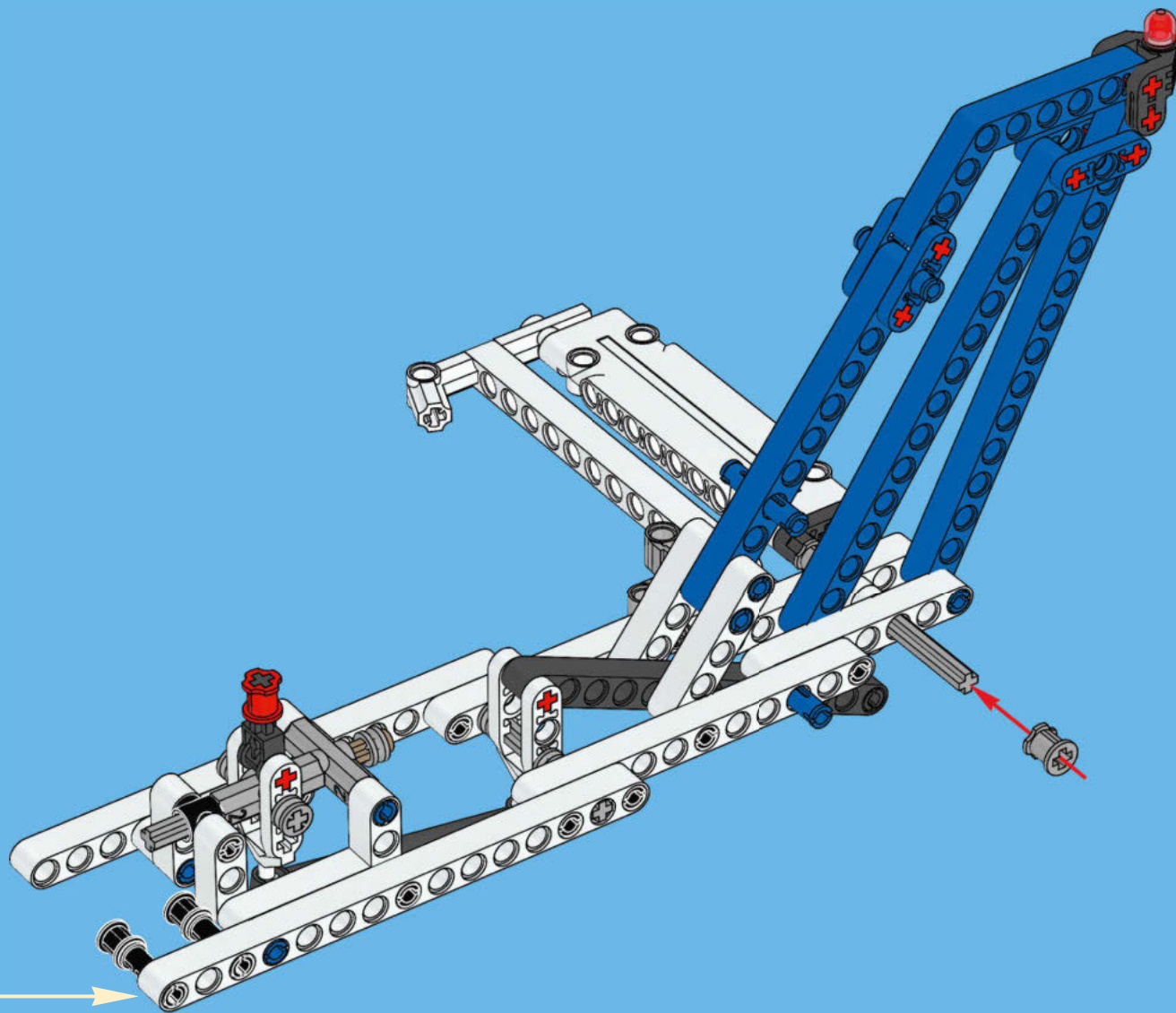

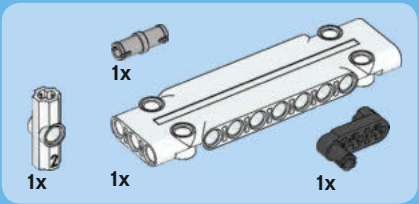

17

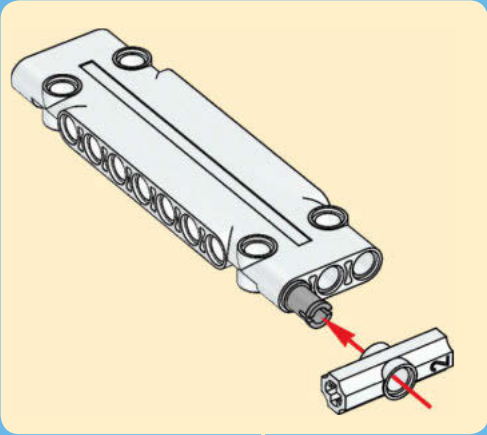
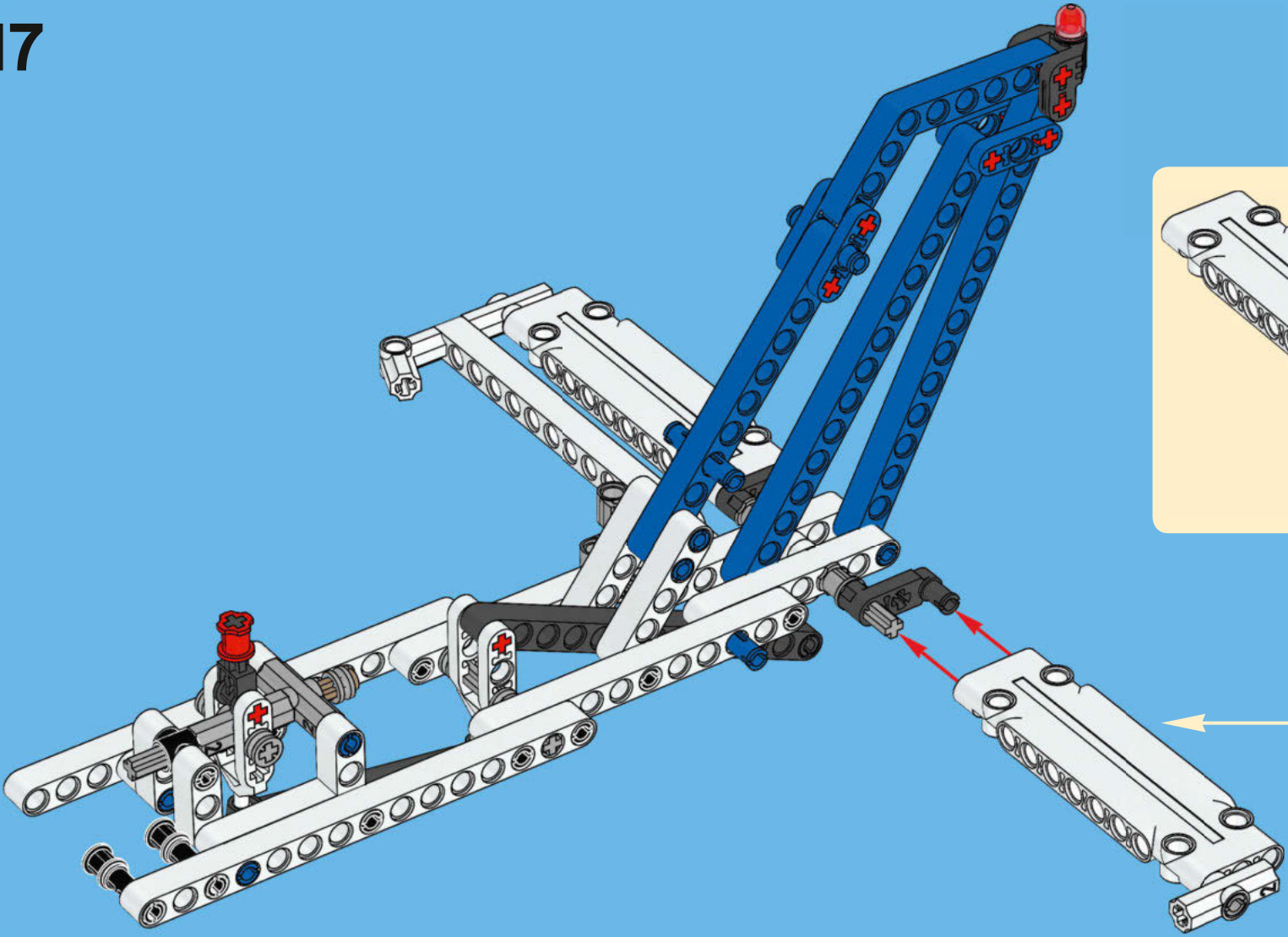

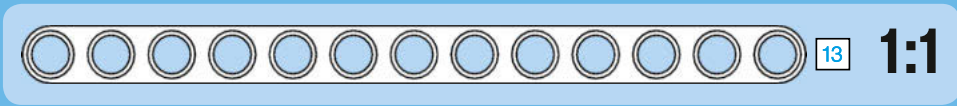
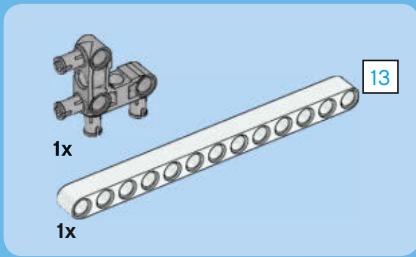

18

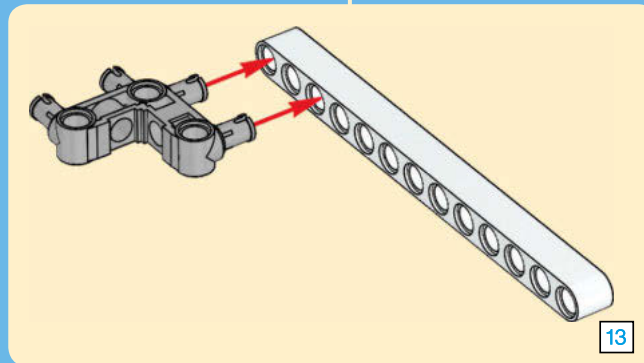
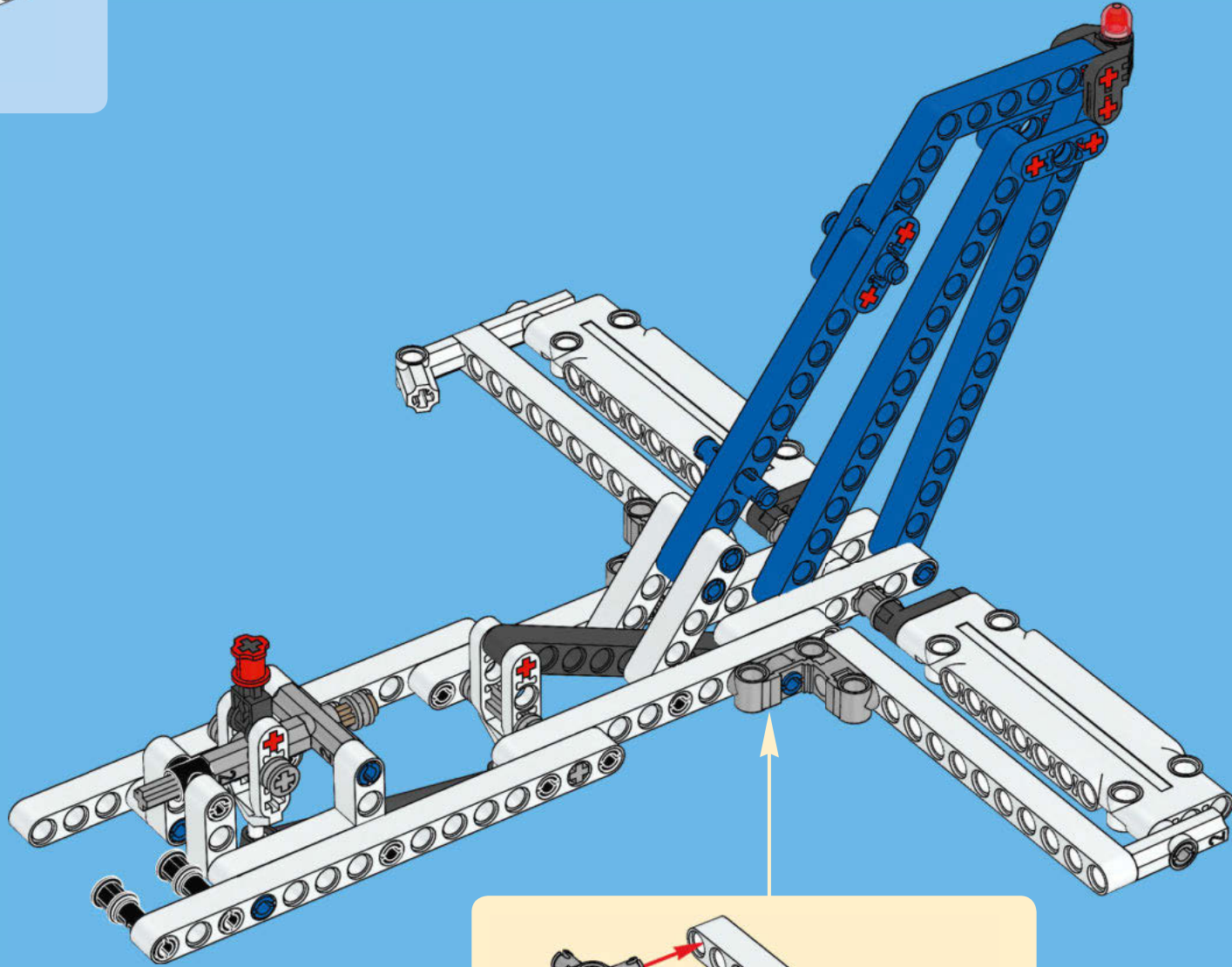

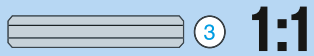
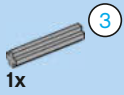

19

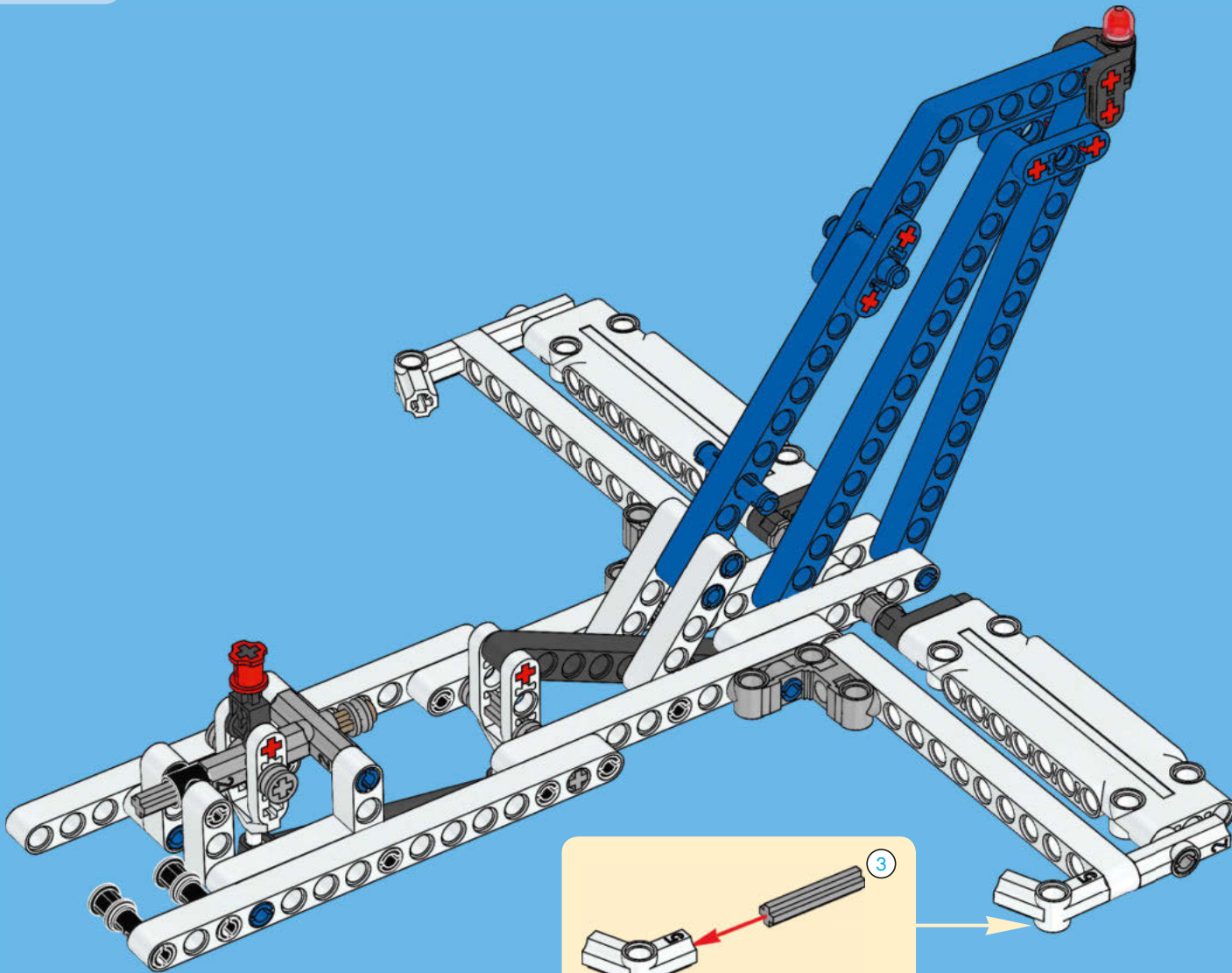

68

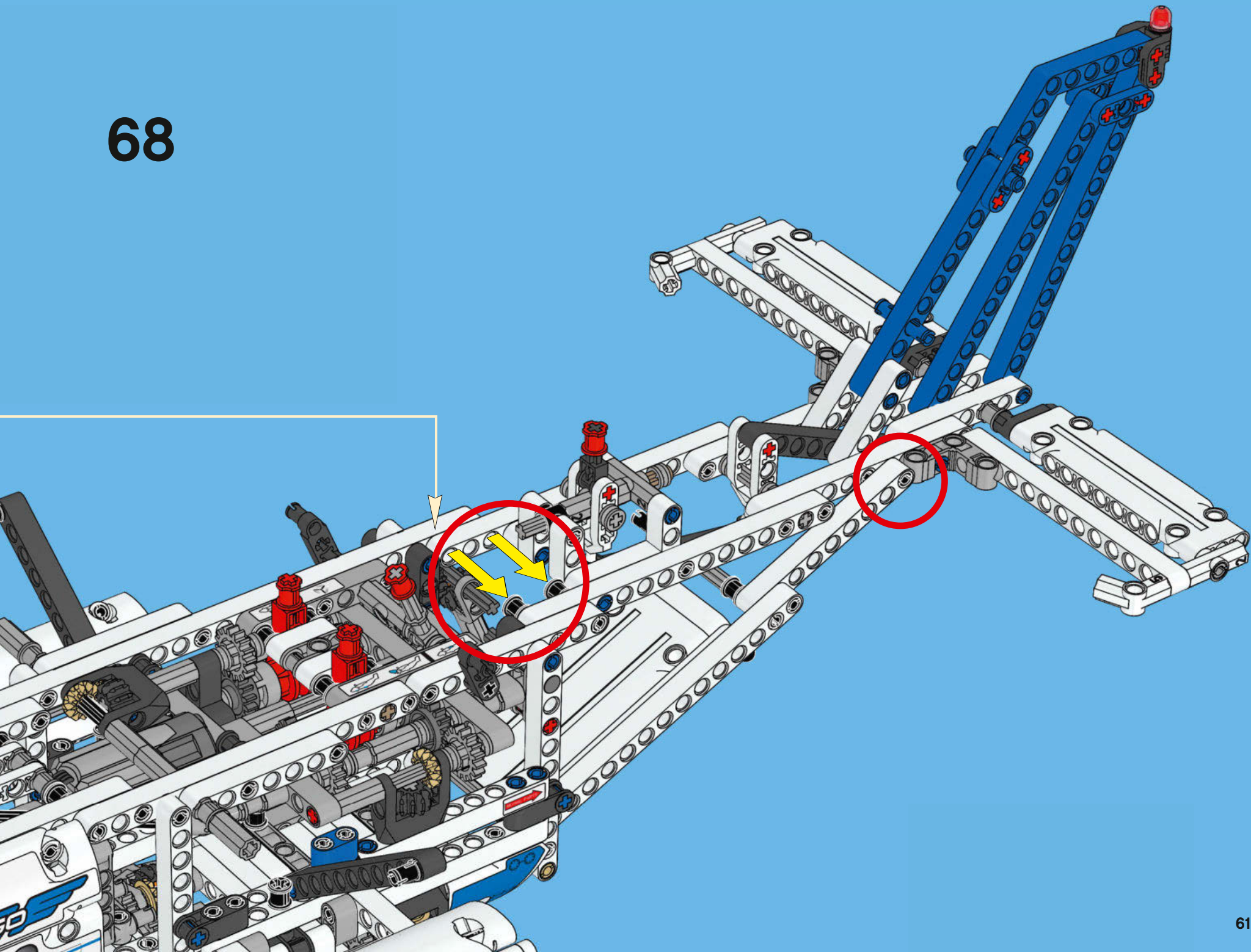



2x



1x

# 69

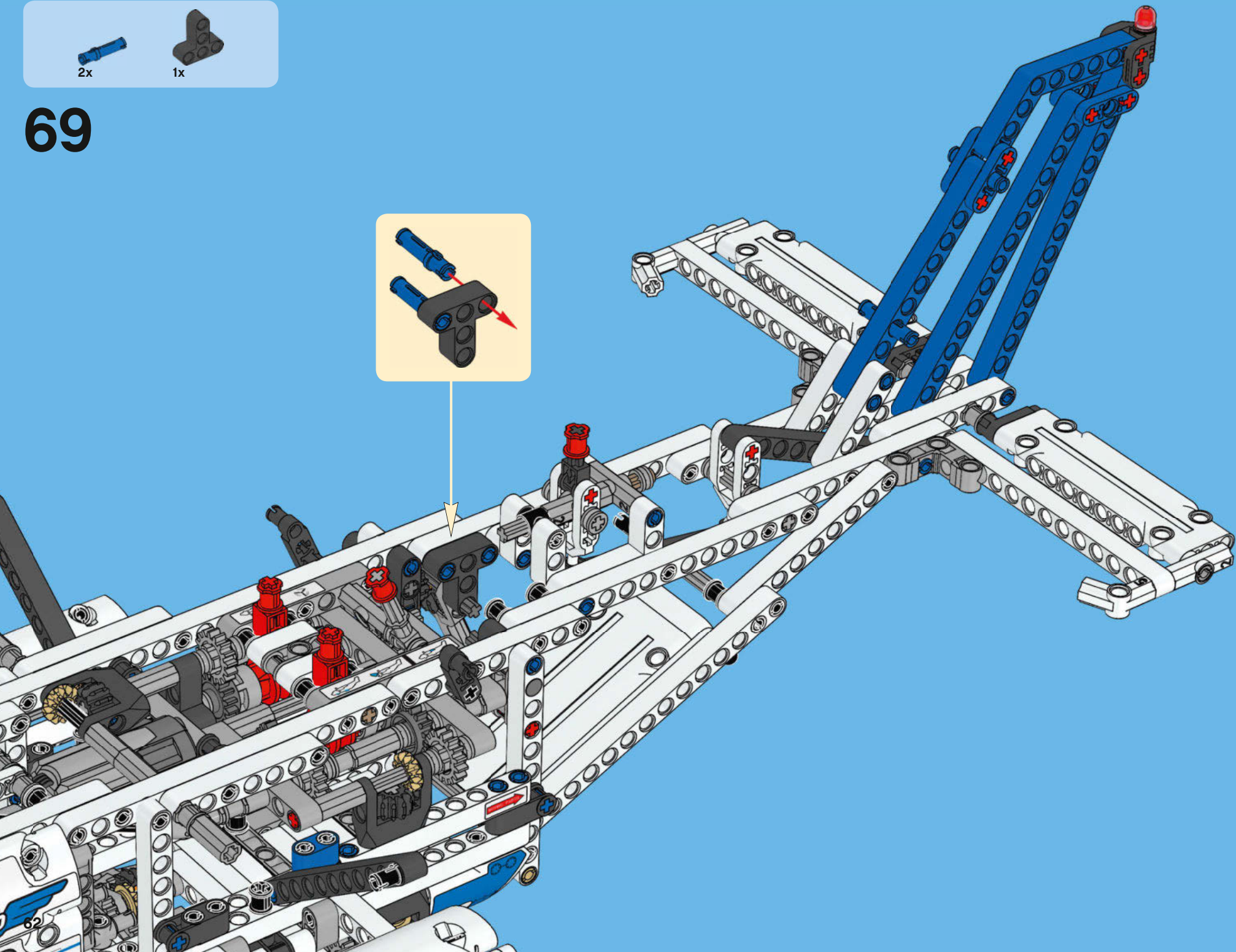

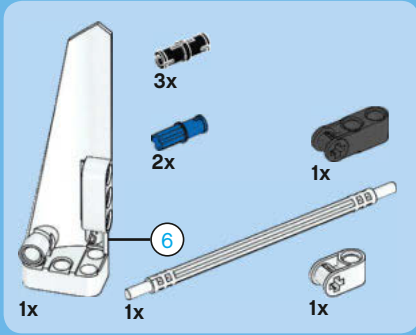

70

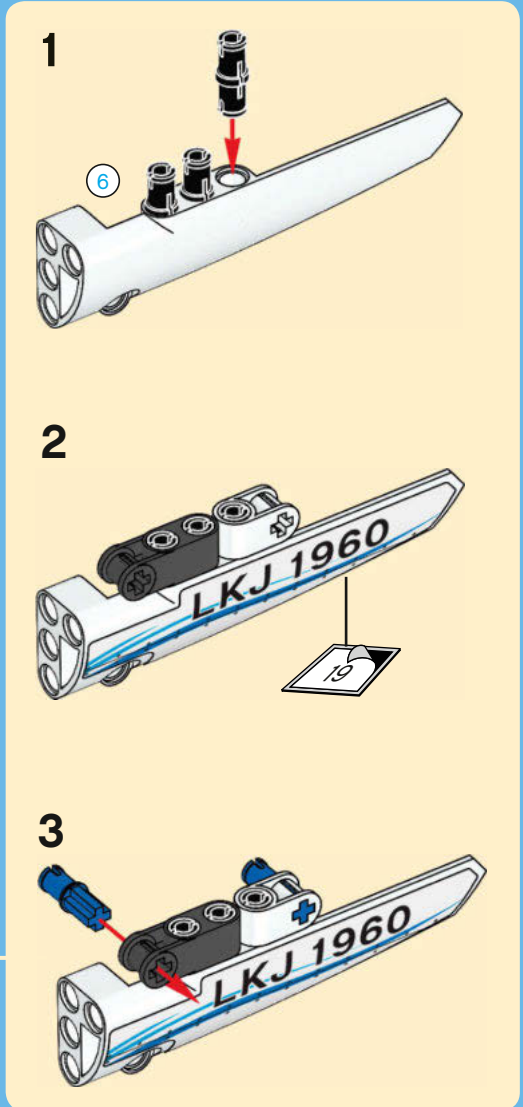
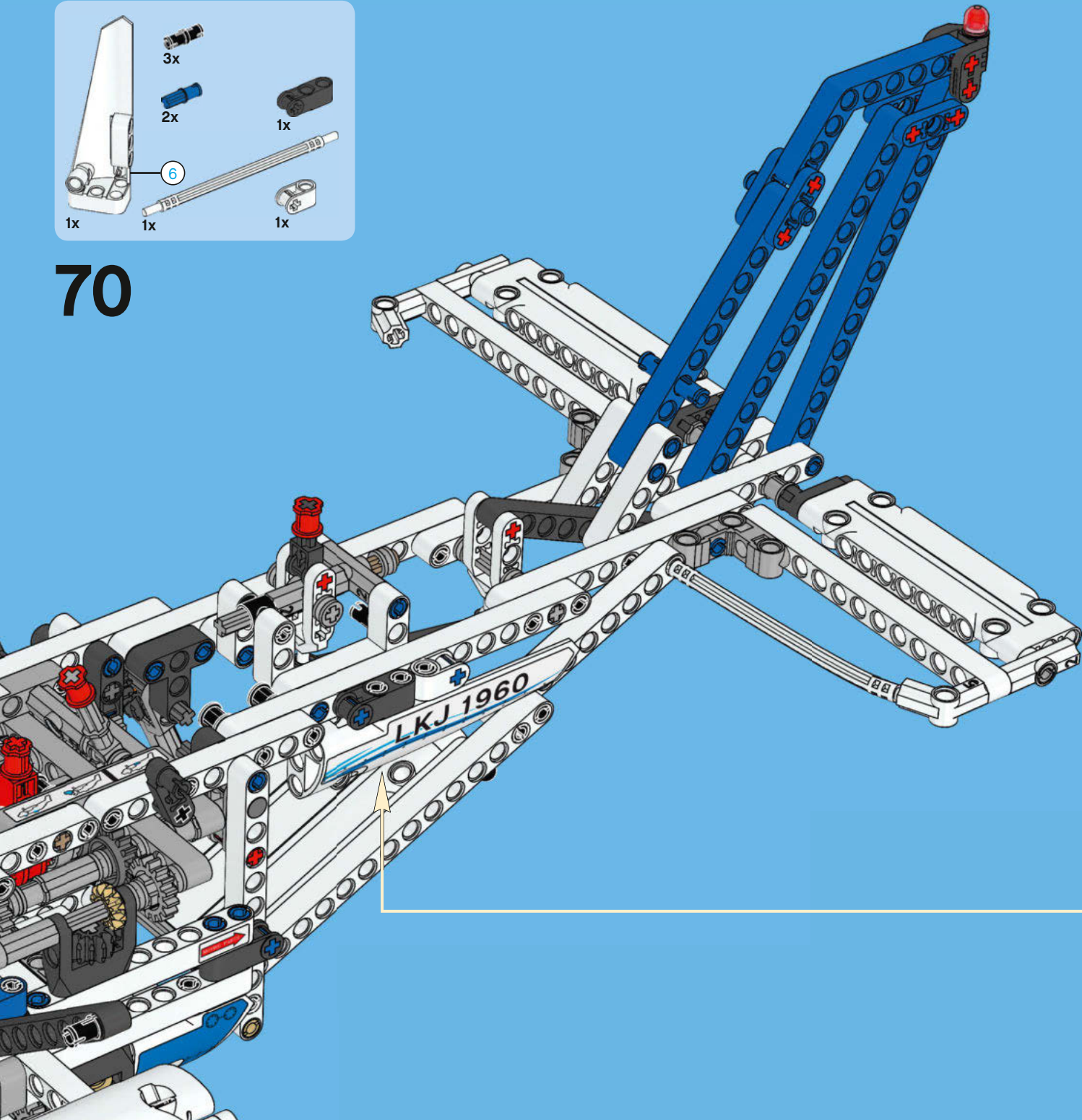

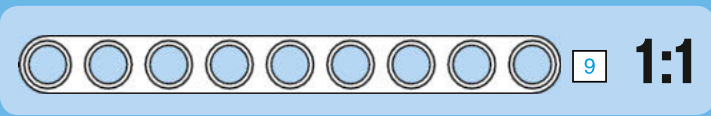
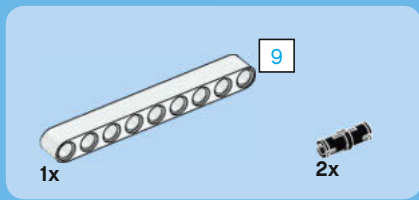

# 71

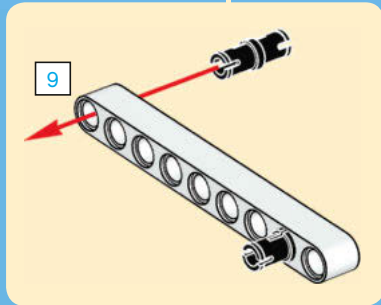
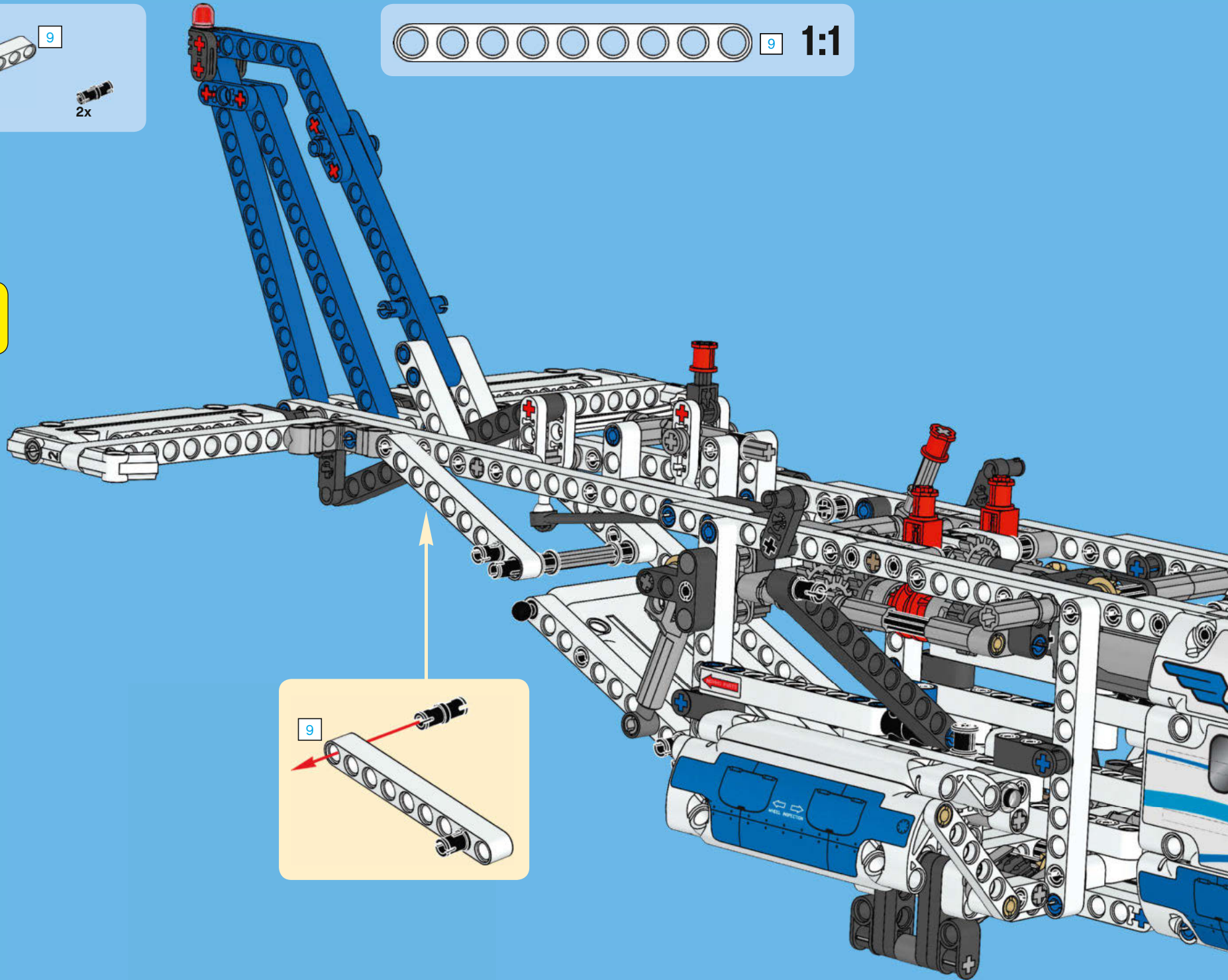



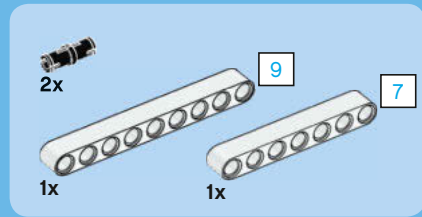

72

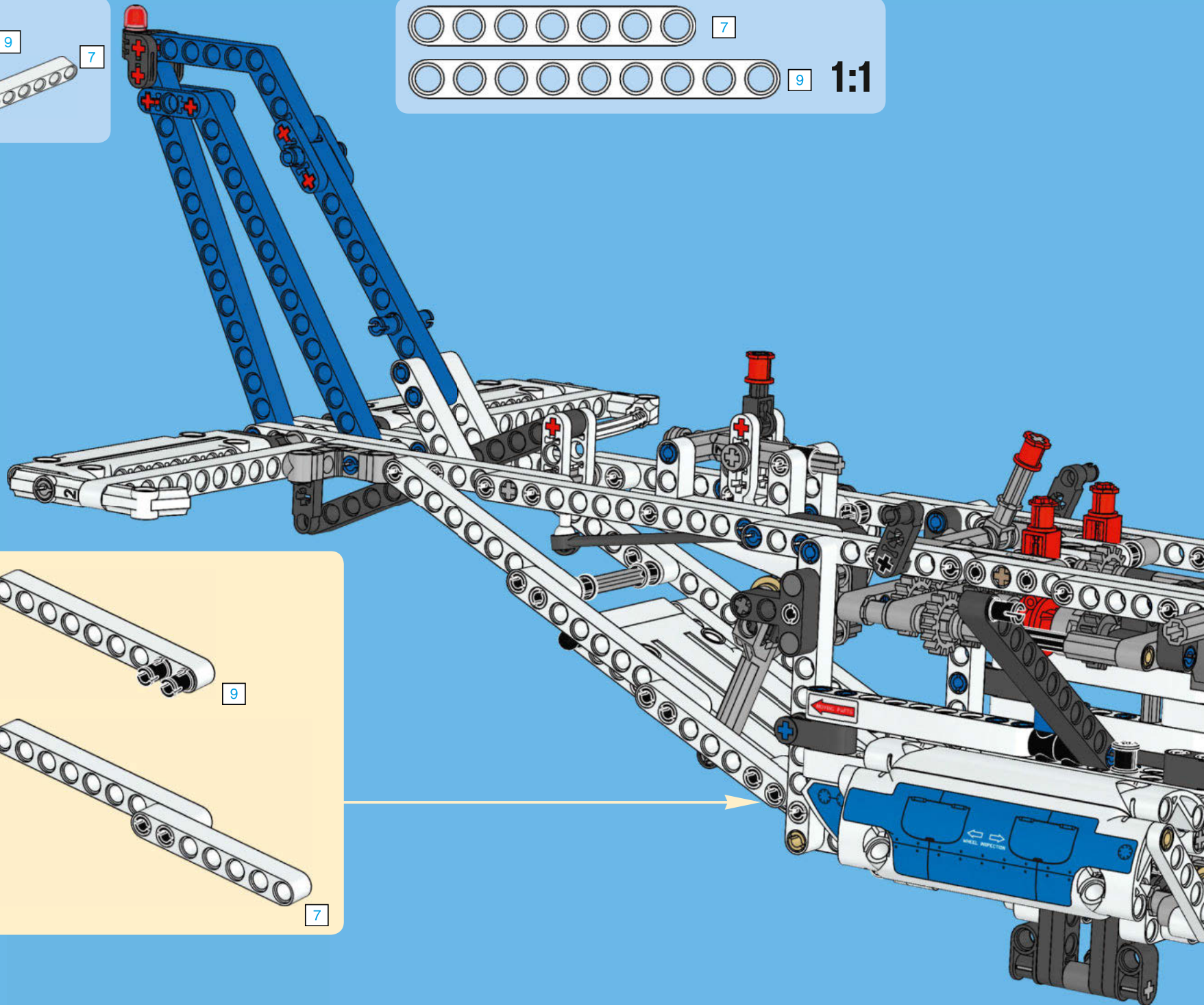
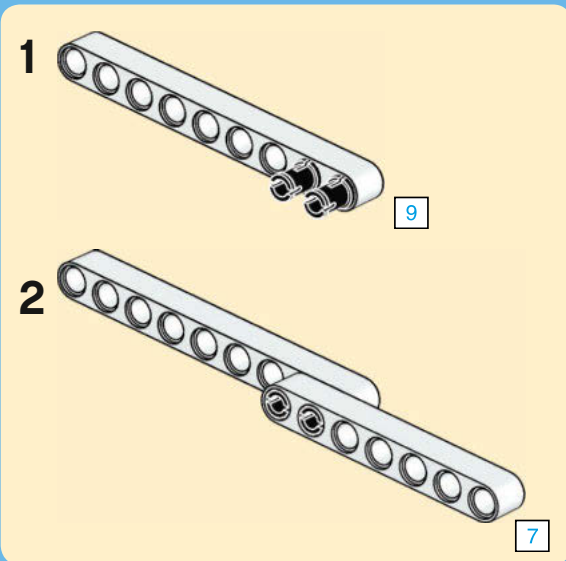
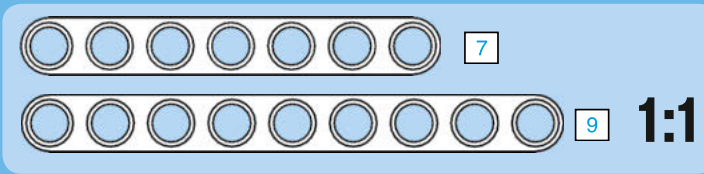

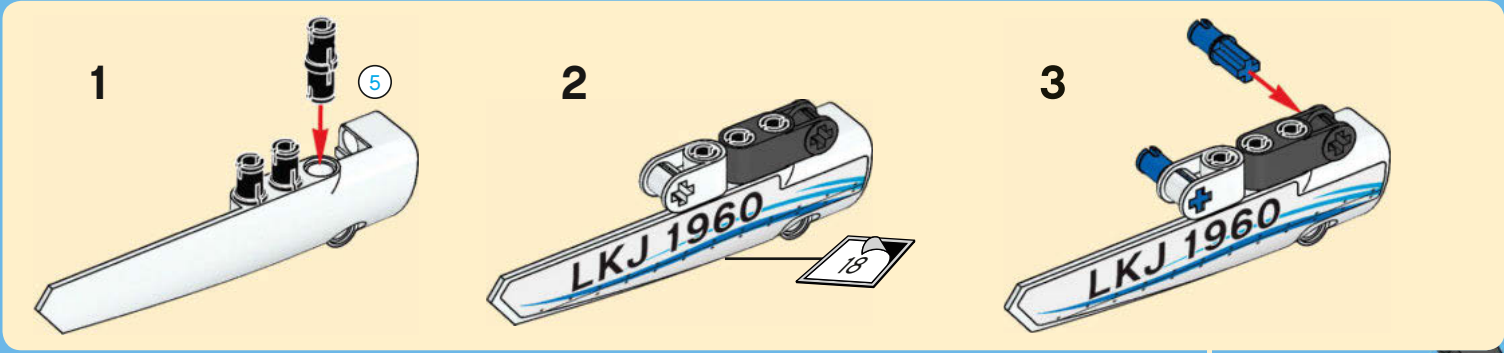
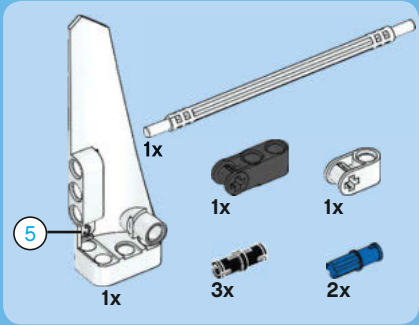

# 73

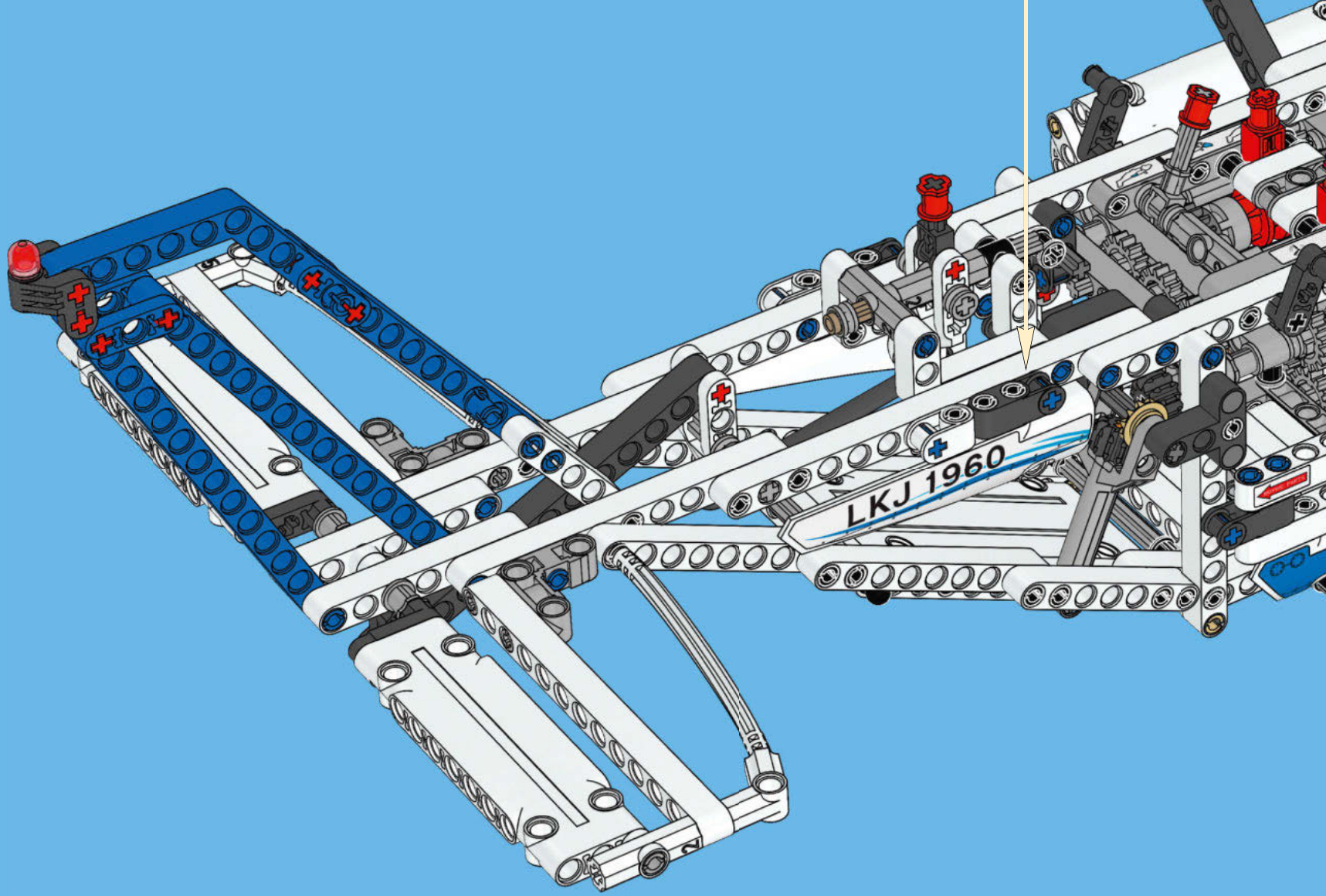

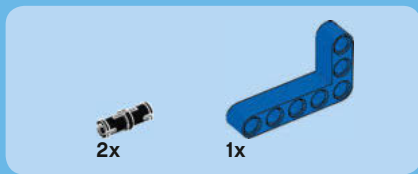

1

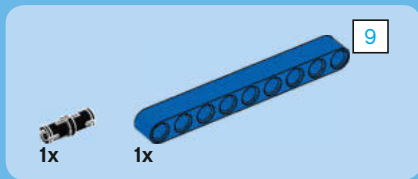
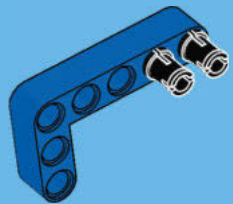

2

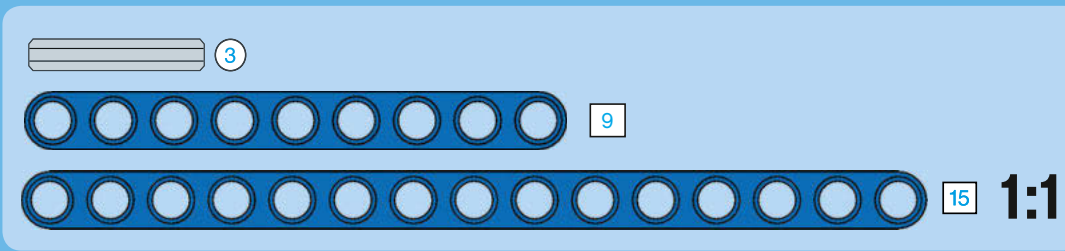
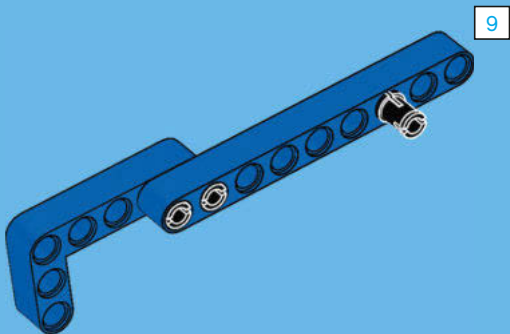

3

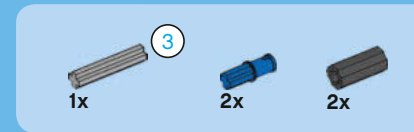
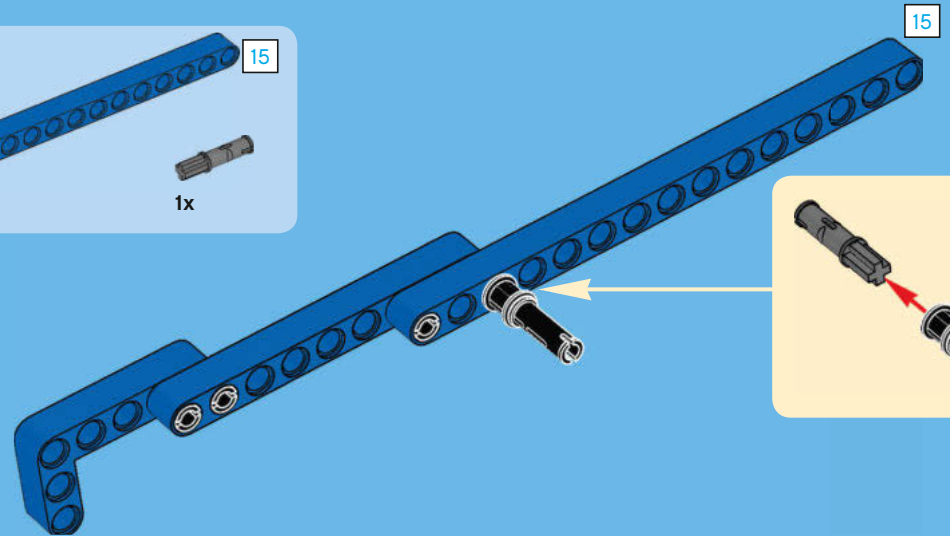
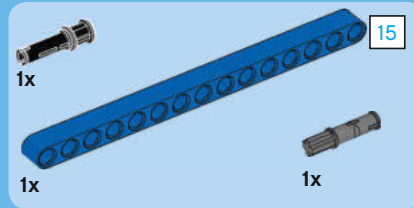

4

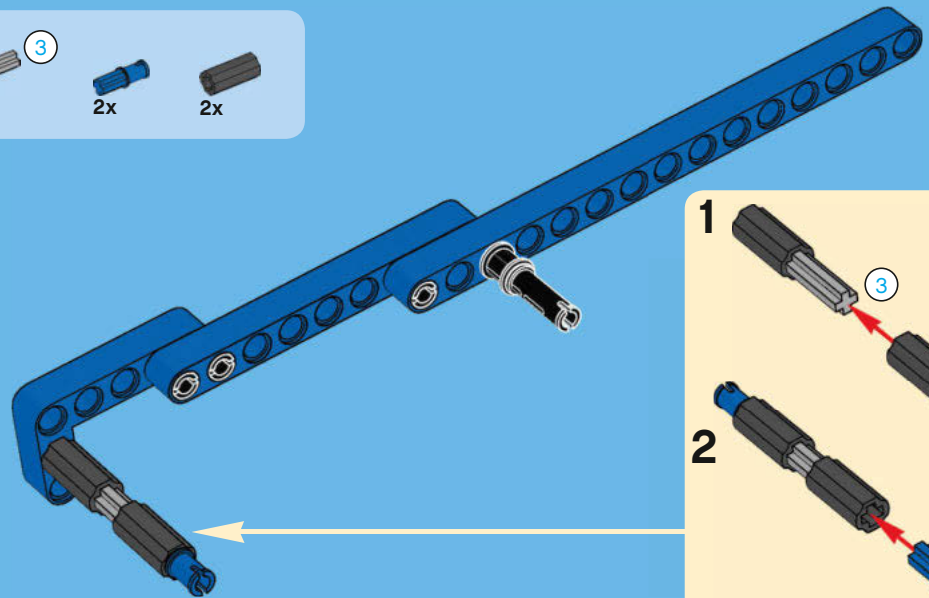

74

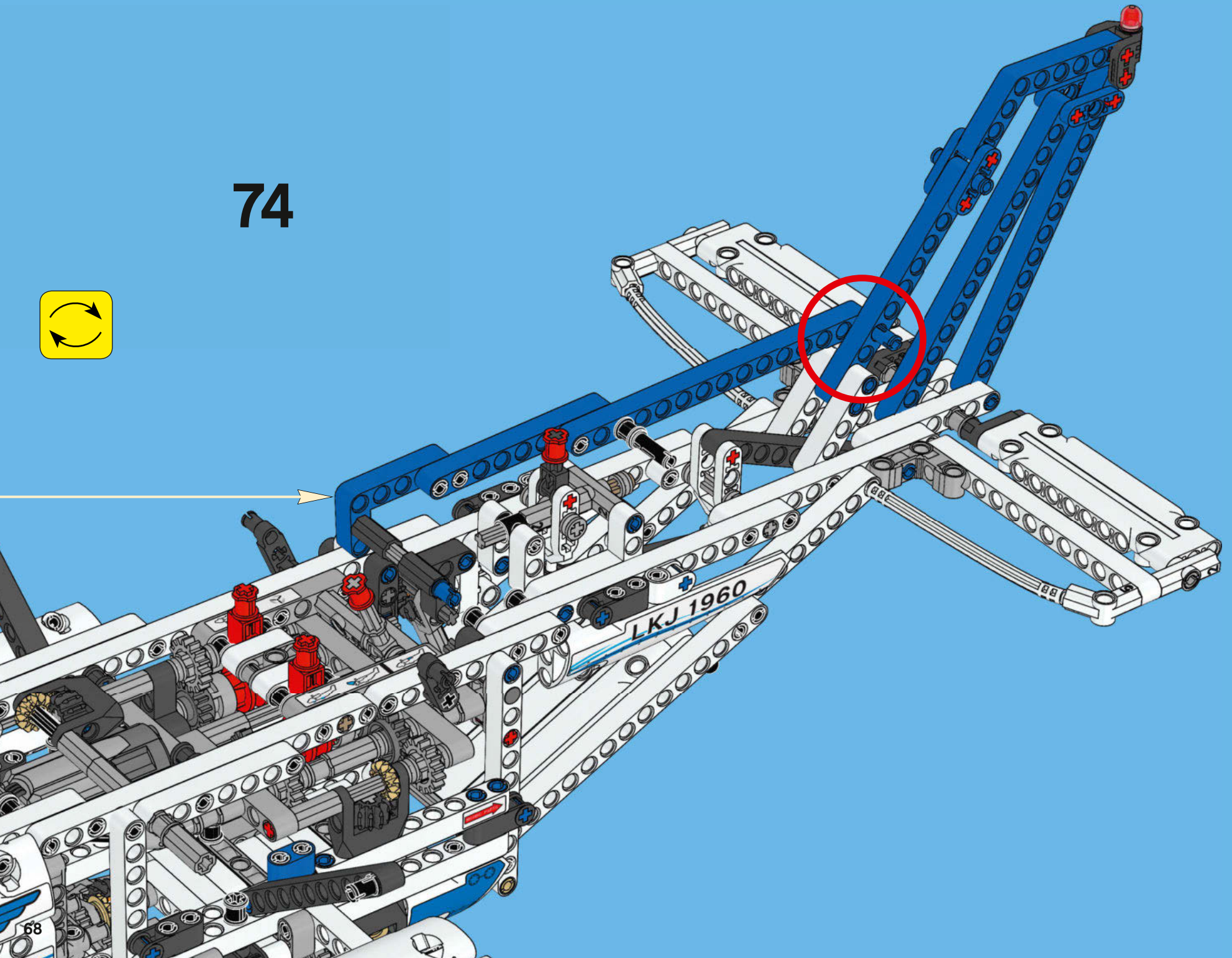

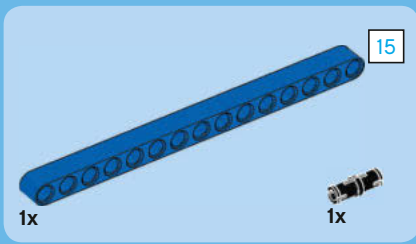

1

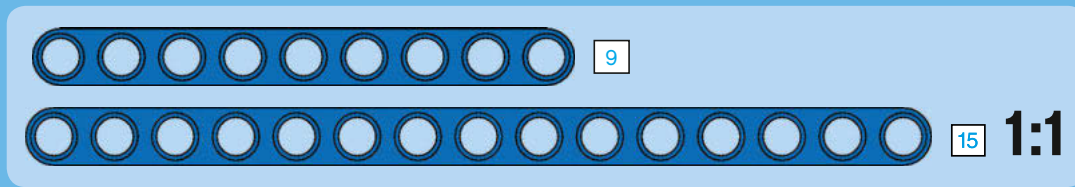

3

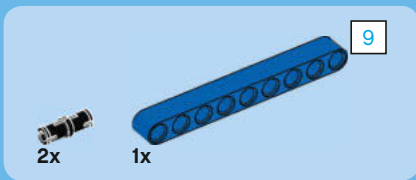
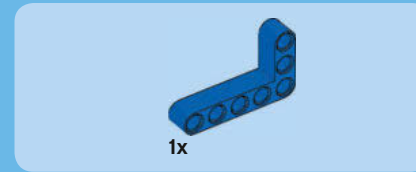

2

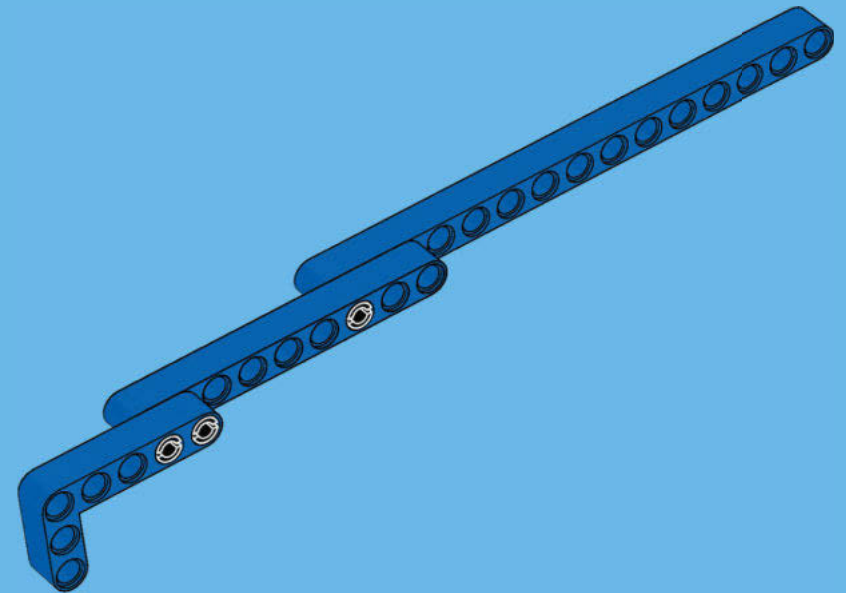
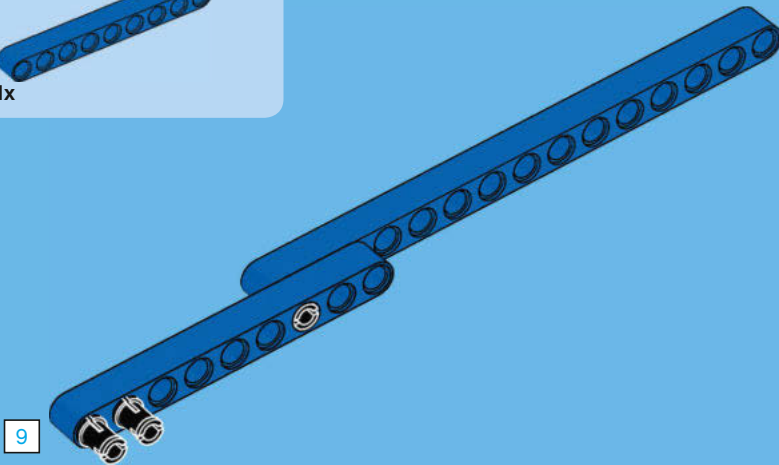

75

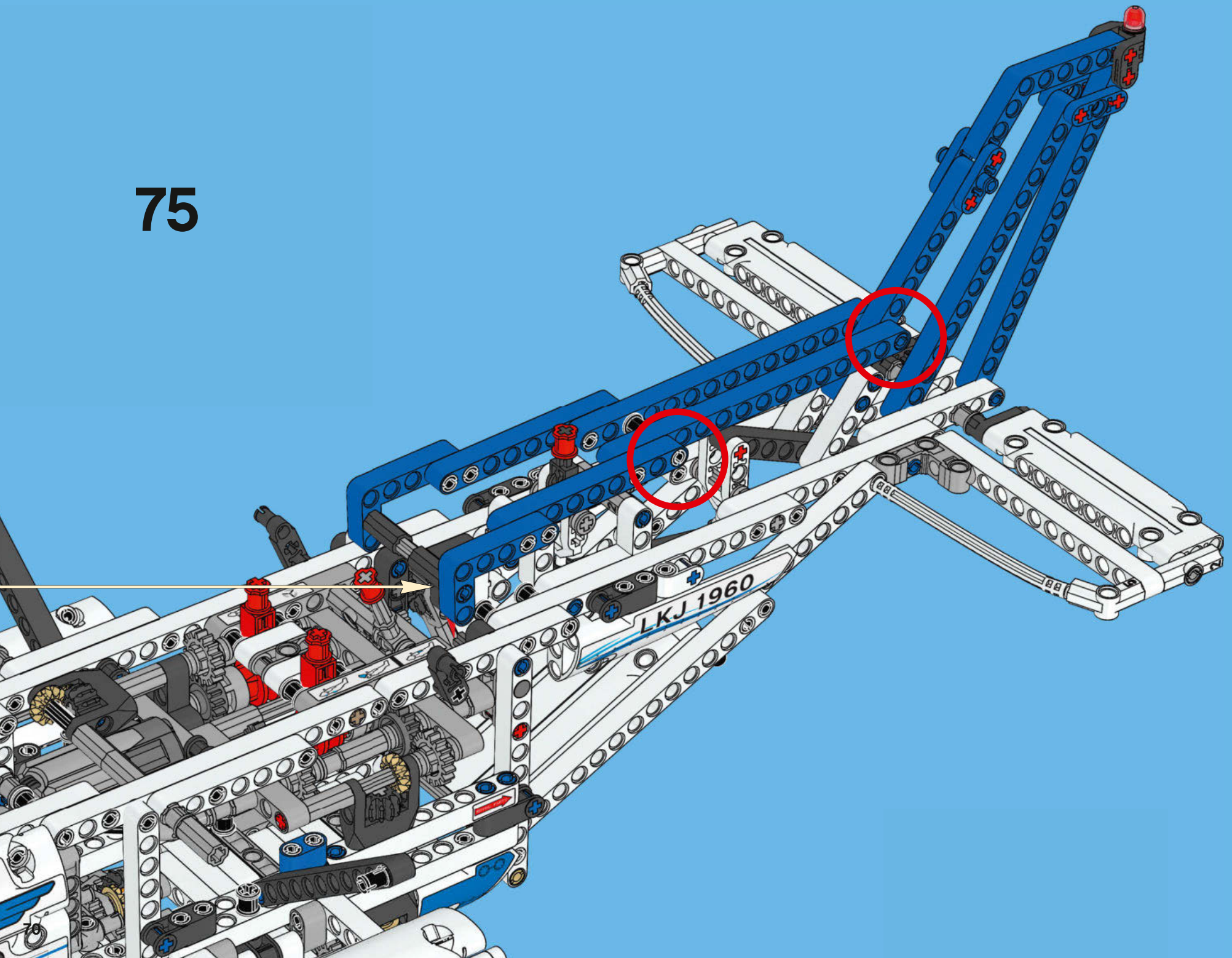



2x

# 76

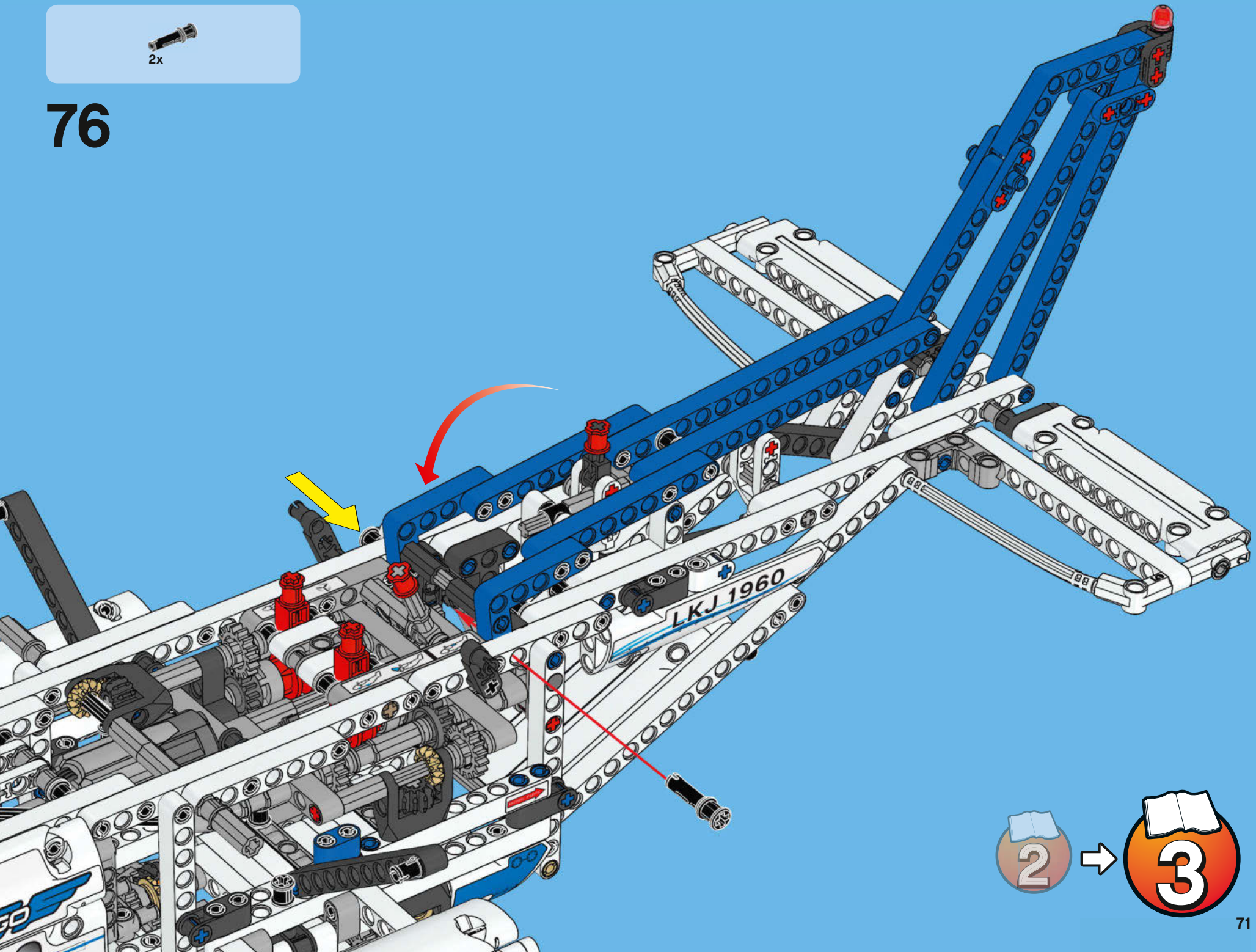



# WIN!

Go to [LEGO.com/productfeedback](http://LEGO.com/productfeedback) to fill out a survey for a chance to win a cool LEGO® Product. No purchase necessary. Open to all residents where not prohibited.



## LEGO.com/productfeedback

### GEWINNE!

Nimm an der Umfrage auf [LEGO.com/productfeedback](http://LEGO.com/productfeedback) teil und hab die Chance ein cooles LEGO® Produkt zu gewinnen!

Die Teilnahme am Gewinnspiel führt zu keinerlei Kaufverpflichtungen. Teilnahme in allen nicht ausgeschlossenen Ländern möglich.

### WIN!

Ga naar [LEGO.com/productfeedback](http://LEGO.com/productfeedback), vul een enquêteformulier in en maak kans op een cool LEGO® product.

Geen aankoopverplichting. Ledereen mag deelnemen, uitgezonderd ingezetenden van landen waar een enquêteverbod geldt.

### GAGNE!

Visite [LEGO.com/productfeedback](http://LEGO.com/productfeedback) pour répondre à un questionnaire et avoir une chance de gagner un produit LEGO® très cool!

Aucune obligation d'achat. Ouvert à tous les résidents des pays autorisés.

### 当てよう!

[LEGO.com/productfeedback](http://LEGO.com/productfeedback) にアクセスして、アンケートにご記入ください。当選者にはレゴ製品を差し上げます。

お買い上げの必要はありません。禁止されていない限り、すべての皆様にご利用いただけます。



[LEGO.com](http://LEGO.com)