



42056 Porsche 911 GT3 RS

Text/Texte: Scott Selkirk Neillands. Ulrik Feldskov Juul.

Photo: Ulrik Jantzen. Tim Trøjborg. Porsche AG.

Design: Kristian Nørby Larsen. Allan Jensen. Jakob Nusbaum.

LEGO and the LEGO logo are trademarks of the/sont des marques de commerce du LEGO Group.

©2016 The LEGO Group.

Porsche, the Porsche Crest, 911 and GT3 are registered trademarks of Porsche AG and used under license.

Porsche, la Porsche Crest, 911 et GT3 sont des marques déposées de Porsche AG et utilisées sous licence.



Booklet available in English on
Livret disponible en français sur
Folleto disponible en español en

4



Welcome
Bienvenue

6



The Heritage of the Perfect Sports Car
L'héritage de la voiture de sport idéale

10



Designing Perfection
Concevoir la perfection

14



The Driver's Point of View
Le point de vue du pilote

18



A Dream Project
Un projet de rêve

26



A Passion for Detail
La passion du détail

30



A LEGO® Memory
Un souvenir LEGO®

34



Producing Excellence
La production de l'excellence

36



Get Ready To Build
Place à la construction

Welcome

With the introduction of the new LEGO® Technic building system in 1977, it suddenly became possible to create more complex LEGO models that mirrored the authentic features and functions of real vehicles. Throughout the years we have constructed cars, motorbikes, trucks and planes: all the time challenging ourselves to add more realistic details and elaborate working elements.

This LEGO Technic interpretation of an iconic Porsche 911 is the latest realization of that goal. We hope you will enjoy building the model and learning more about the story behind its development. ✖

Bienvenue

Avec l'introduction du nouveau système de construction LEGO® Technic en 1977, il est devenu possible de créer des modèles LEGO plus complexes qui reflétaient les fonctionnalités authentiques des vrais véhicules. Au fil des années, nous avons construit des voitures, des motos, des camions et des avions, en nous lançant constamment des défis pour ajouter des détails plus réalistes et élaborer des éléments qui fonctionnent.

Cette interprétation LEGO Technic de la célèbre Porsche 911 est la nouvelle réalisation de cet objectif. Nous espérons que vous aimerez construire ce modèle et en savoir plus sur l'histoire de son développement. ✖

*In the beginning I looked around
but couldn't find the car I dreamt of,
so I decided to build it myself.*

FERRY PORSCHE

*Au départ, je cherchais la voiture de mes
rêves mais je ne la trouvais pas, alors j'ai
décidé de la construire moi-même.*

FERRY PORSCHE





*Dieter Landenberger, manager of the Historical Archives of Porsche AG in the workshop of the Porsche Museum.
Dieter Landenberger, directeur des archives historiques de Porsche AG dans l'atelier du Musée Porsche.*

The Heritage of the Perfect Sports Car

"The philosophy of the company is as unique as its cars. Every model that bears the Porsche crest on the hood must combine sporting performance with everyday usability. It's this intelligent combination of design, performance and efficiency that makes Porsche cars so special."

As manager of the Historical Archives of Porsche AG with the responsibility for the heritage of the Porsche brand, Dieter Landenberger, is perfectly placed to tell us about Porsche's design DNA and the key role the 911 model has played in the company's goal of creating the perfect sports car.

"For more than half a century the Porsche 911 has been revered as an iconic automobile and the very epitome of the sports car. The 911 has consistently gone its own way, not only in terms of design, but also with regard to technology. The timeless design of the 911 series is undoubtedly a vital element of that legacy; it blends emotion with functionality.

"The Porsche designers responsible for the seven 911 generations so far have been consistently indifferent to passing fads. On the contrary, the design has been continuously evolved taking great care to preserve its unique identity. 'Form follows function' has been a natural guiding principle throughout."

L'héritage de la voiture de sport idéale

« La philosophie de l'entreprise est aussi unique que ses voitures. Chaque modèle qui porte l'écusson Porsche sur le capot doit combiner une performance sportive avec une utilité quotidienne. C'est cette combinaison intelligente de design, de performance et d'efficacité qui rend les voitures Porsche si spéciales. »

En tant que directeur des archives historiques de Porsche AG et responsable de l'héritage de la marque Porsche, Dieter Landenberger est bien placé pour nous parler de l'ADN du design de Porsche et du rôle essentiel joué par le modèle 911 dans l'objectif de l'entreprise : créer la voiture de sport idéale.

« La Porsche 911 est vénérée depuis plus d'un demi-siècle en tant que voiture emblématique et voiture de sport par excellence. La 911 a toujours tracé son propre chemin, non seulement en termes de design, mais aussi en matière de technologie. Le design intemporel de la série 911 est incontestablement un élément vital de cet héritage, combinant l'émotion et la fonctionnalité. »

« Les concepteurs des sept générations de la Porsche 911 ont été constamment indifférents aux modes éphémères. Le design a au contraire évolué en permanence, en prenant grand soin de préserver son identité unique. "La forme suit la fonction" a toujours été un principe directeur naturel. »



◀ "In the course of the last fifty years our engineers have regularly reinvented the 911. With innovations such as the three-spoke safety steering wheel (1963), Targa roll bar (1965), internally ventilated disk brakes (1966), front and rear spoilers (1972), exhaust gas turbocharger (1974), hot-dip galvanized body shell (1975), intercooler (1977), Digital Motor Electronics (1983), Tiptronic (1989), aluminum chassis (1993), On-Board Diagnosis (1995), ceramic brake disks (2001), dual clutch transmission (2008), or seven-speed manual transmission (2011)—the 911 has repeatedly set new technological benchmarks.

"The 911 has always been committed to the performance principle and motor racing is its most important test lab. From the very beginning, it has been at home on circuits all over the world, earning itself a reputation as a versatile and reliable winning vehicle. It should come as no surprise to learn that a good two-thirds of Porsche's tally of 30,000 race victories to date were notched up by the 911."

"With the new 911 GT3 RS, Porsche continues the heritage of street-legal, high-performance models. For the Porsche brand these models are very important.

With their extraordinary performance and sportiness they are pure drivers' cars. The new 911 GT3 RS maintains the basic idea of Ferry Porsche who once said: 'Driving enjoyment is not created by comfort, but quite the opposite.'" ✖

« Au cours des cinquante dernières années, nos ingénieurs ont régulièrement réinventé la 911. Avec des innovations telles que le volant de sécurité à trois rayons (1963), l'arceau Targa (1965), les freins à disque à ventilation interne (1966), les becquets avant et arrière (1972), le turbocompresseur à gaz d'échappement (1974), la carrosserie en acier galvanisé à chaud (1975), le refroidisseur intermédiaire (1977), la gestion moteur numérique (DME) (1983), la boîte de vitesses Tiptronic (1989), le châssis en aluminium (1993), le diagnostic embarqué (1995), les plaquettes de frein en céramique (2001), la boîte de vitesses à double embrayage (2008), ou la transmission manuelle à 7 rapports (2011), la 911 a marqué de nouvelles étapes technologiques en permanence.

La 911 a toujours été fidèle au principe de performance et la course automobile est son laboratoire d'essai le plus important. Depuis le tout début, elle a été à l'aise sur les circuits du monde entier, se faisant une réputation de voiture performante, polyvalente et fiable. Il n'est donc pas surprenant de constater que les deux tiers des 30 000 victoires en course de Porsche à ce jour ont été remportés par la 911.

Avec la nouvelle 911 GT3 RS, Porsche poursuit cet héritage de modèles homologués pour la route et hautement performants. Pour la marque Porsche, ces modèles sont très importants.

Avec leur performance extraordinaire et leur côté sportif, ce sont des voitures destinées aux conducteurs passionnés. La nouvelle 911 GT3 RS maintient l'idée de base de Ferry Porsche qui a déclaré un jour : "Le plaisir de la conduite n'est pas créé par le confort, bien au contraire." » ✖



1973: 911 Coupé (Original 911)/1973 : 911 (911 d'origine) Coupé



1992: 911 Carrera 2 Targa (Type 964)/1992 : 911 (Type 964) Carrera 2 Targa



1974: 911 Carrera Coupé (G Series)/1974 : 911 (Série G) Carrera Coupé



2001: 911 Carrera Coupé (Type 996)/2001 : 911 (Type 996) Carrera Coupé



Designing Perfection

If the address 'Porsche Straße 911' is not enough in itself, the roaring sounds from the nearby test track will soon convince you that the Porsche Development Center at Weissach, close to Stuttgart, is a very special place. This is where all Porsches are designed and tested, and concepts like the Porsche 911 GT3 RS are refined to perfection by the Head of GT Cars, Andreas Preuninger, and his team of designers, engineers and mechanics.

As the leader of the team responsible for the current range of GT cars at Porsche, there is no one better than Mr Preuninger to describe why the latest Porsche 911 GT3 RS is such a special driving experience.

"First of all, the base car we start from—the 911—is without a doubt the best driver's car in the world. Secondly, we shouldn't forget that we make the car better for the specific needs of our special target group and not necessarily for everybody. The focus is to make the car a true driver's car without having to care about all the compromises a more all-round sports car has to consider."

Concevoir la perfection

Si l'adresse « Porsche Straße 911 » ne suffit pas en elle-même, les vrombissements du circuit de test à proximité montrent rapidement que le Centre de développement Porsche à Weissach, à proximité de Stuttgart, est un endroit très spécial. C'est le lieu où toutes les Porsche sont conçues et testées et où des concepts tels que celui de la Porsche 911 GT3 RS sont raffinés à la perfection par le chef de la division des voitures GT, Andreas Preuninger, et son équipe de concepteurs, d'ingénieurs et de mécaniciens.

En tant que chef de l'équipe responsable de la gamme actuelle de voitures GT chez Porsche, M. Preuninger est le mieux placé pour expliquer pourquoi la Porsche 911 GT3 RS offre une expérience de conduite si spéciale.

« Tout d'abord, la voiture de base avec laquelle nous commençons, la 911, est sans aucun doute la meilleure voiture du monde. Deuxièmement, nous ne devons pas oublier que nous améliorons la voiture pour les besoins spécifiques de notre groupe cible spécial et pas nécessairement pour tout le monde. L'objectif est de faire de cette voiture une vraie voiture de conducteur sans avoir à se préoccuper de tous les compromis associés à une voiture de sport plus générique. »



Andreas Preuninger (right), Head of GT Cars, discusses the model with Senior LEGO Designer Uwe Wabra.

Andreas Preuninger (à droite), chef de la division des voitures GT, parle du modèle avec le designer principal LEGO, Uwe Wabra.

- “The car has to transmit a lot of information to the driver, melt into one with him and give him that seat-of-the-pants feeling; it has to become his prolonged arm. Another important point is the mechanical character of all the technology involved; it's not a bad thing if you feel and hear the valves hissing, gears turning or even whining, that gives the car identity and character... Some edges here and there are welcome in a true motoring car.”

“It's important for us that the car has to be pleasing to the eye, while also looking purposeful and mildly aggressive... But all the components have to function efficiently to make the car perform as well as possible. It's 'form follows function', but only if the form looks cool, if you know what I mean.”

So what did Mr Preuninger think when he saw the final LEGO Technic version of his car? “I was astonished about how much resemblance could be achieved to the real car just using LEGO components. The specific creases in the hood and roof, the openings in the fenders, the big wing and air intakes are all there, so you can see at first glance this is an RS. The way working features such as the paddle-shift PDK gearing system have been integrated into the model is just amazing.”

« La voiture doit transmettre de nombreuses informations au conducteur, ne faire qu'un avec lui et lui donner cette sensation de fusion; elle doit devenir le prolongement de son bras. Un autre point important est le caractère mécanique de toute la technologie impliquée. Ce n'est pas une mauvaise chose si vous sentez et que vous entendez les valves siffler, les engrenages tourner, ou même grincer, cela donne une identité et un caractère à la voiture... Des caractéristiques de ce type ici et là sont bienvenues dans une vraie voiture de sport.

Il est important pour nous que la voiture soit agréable à regarder, tout en ayant aussi l'air déterminée et légèrement agressive... Mais tous les composants doivent fonctionner efficacement pour que la voiture soit aussi performante que possible. “La forme suit la fonction”, mais seulement si la forme est cool, si vous voyez ce que je veux dire. »

Qu'a donc pensé M. Preuninger quand il a vu la version LEGO Technic finale de sa voiture ? « J'ai été stupéfait de voir à quel point elle pouvait ressembler autant à la vraie voiture seulement en utilisant des composants LEGO. Les rainures spécifiques dans le capot et le toit, les ouvertures des ailes, le grand aileron et les prises d'air, tout est là, et l'on peut voir du premier coup d'œil que c'est une RS. La façon dont des caractéristiques fonctionnelles, notamment le système de changement de vitesse PDK, ont été intégrées au modèle est tout simplement incroyable. »



*To be truly aesthetic, truly timeless,
any design must be functionally justified.*

FERRY PORSCHE



*Pour être véritablement esthétique,
véritablement intemporel, tout design
doit être justifié fonctionnellement.*

FERRY PORSCHE





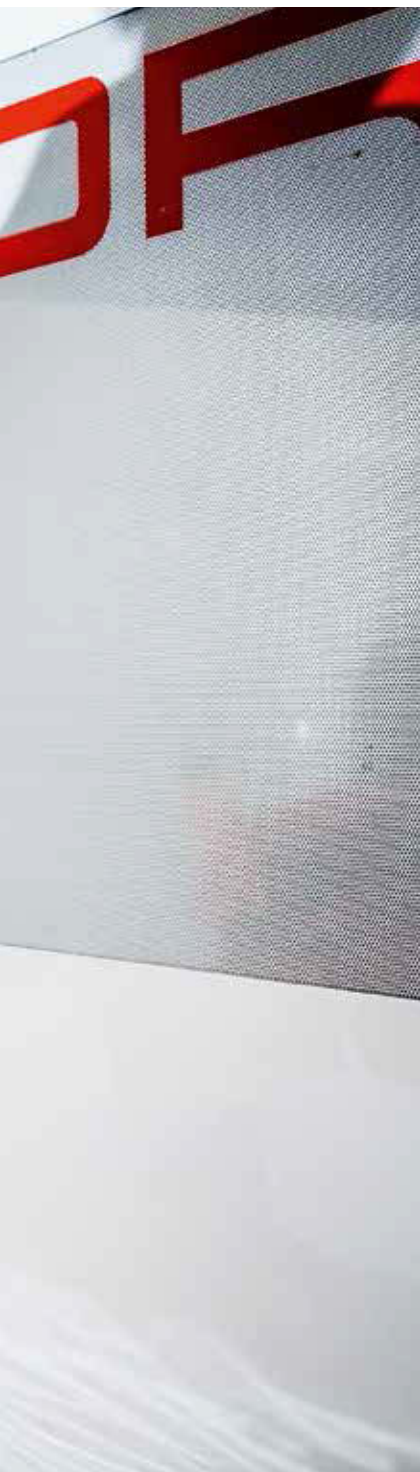

The Driver's Point of View

It may seem a long way from the karting tracks in his native New Zealand to the professional race circuits of Le Mans and Daytona, but for racing driver Brendon Hartley the goal has always been the same: "I want to win. In everything I do."

As a Porsche Works driver and a member of one of the most successful endurance racing teams competing today, the 26-year-old lives and breathes for anything with four wheels and an engine.

Brendon clearly remembers his first impressions of a car that has often been described as the closest you can get to a race car for the road: "The 911 GT3 RS is the first road car I have driven that gave me goose pimples. I only drove it from Weissach to a hotel down the road, but all my senses were overloaded with joy: the sound, the vibration when the revs got close to the red line, the feeling

Le point de vue du pilote

La route peut sembler longue entre les pistes de kart de sa Nouvelle-Zélande natale et les circuits professionnels du Mans et de Daytona, mais pour le pilote de course Brendon Hartley, l'objectif a toujours été le même : « Je veux gagner. Dans tout ce que je fais. »

En tant que pilote de l'équipe officielle Porsche et membre de l'une des meilleures équipes de course d'endurance, ce pilote de 26 ans se passionne pour tout ce qui a quatre roues et un moteur.

Brendon se souvient clairement de ses premières impressions d'une voiture souvent décrite comme ce qui se rapproche le plus d'une voiture de course pour la route : « La 911 GT3 RS est la première voiture de route qui m'a donné des frissons quand je l'ai conduite. Je l'ai conduite seulement de Weissach à un hôtel pas très loin, mais tous mes sens débordaient de joie : le son, la vibration quand elle s'approche du plein régime, la sensation de la route transmise par le volant, la position basse, comme une voiture de course, tout m'a rappelé l'excitation d'être dans une voiture de course, et pourtant je peux la prendre pour aller faire mes courses ! »

Porsche Works driver, Brendon Hartley. Winner of the FIA World Endurance Driver's Championship 2015.

Le pilote de l'équipe officielle Porsche Brendon Hartley, gagnant du Championnat du monde d'endurance FIA 2015.



of the road through the steering wheel, the low, race-car-like position—it all gave me flash backs of the thrills of being in a race car, yet I could take this down the road for the grocery shopping!

"The car has more down-force, more mechanical grip from the tires, more horsepower and more muscle, which means it's hard for anybody not to do a double-take as it passes."

His meeting with the LEGO Technic version of the car was also a positive experience, and one that brought back memories of his childhood: "It's amazing. My brother and I were big LEGO enthusiasts as kids, so when I saw this I immediately thought of all the fun I would have pulling it apart and putting it back together. After the initial delight at the way it looked and the fact that they could really convey the lines of the 911 GT3 RS with standard LEGO Technic parts, I was then impressed to see a fully working gearbox and engine."

"My only question after that was: when can I have one?"

« La voiture a plus de déportance, d'accroche mécanique des pneus, plus de puissance et plus de muscle, ce qui fait qu'il est difficile pour tout le monde de ne pas marquer un temps d'arrêt quand elle passe. »

Sa rencontre avec la version LEGO Technic de la voiture a aussi été une expérience positive, qui lui a rappelé des souvenirs d'enfance. « C'est incroyable. Mon frère et moi étions de grands fans LEGO quand nous étions enfants, alors quand j'ai vu ça, j'ai immédiatement pensé à quel point j'allais m'amuser à la démonter et à la reconstruire. Après la joie initiale en découvrant son aspect et le fait que l'on pouvait vraiment reproduire les lignes de la 911 GT3 RS avec des pièces LEGO Technic standard, j'ai aussi été impressionné de découvrir une boîte de vitesses et un moteur qui fonctionnent.

Ma seule question après ça : quand puis-je en avoir une ? »



Brendon Hartley winning for Porsche at the Nürburgring 2015.
Brendon Hartley, gagnant pour Porsche au circuit Nürburgring 2015.

*Andrew Woodman, Senior Design Manager for LEGO Technic, at the Porsche production line.
Andrew Woodman, responsable principal du design LEGO Technic, à la ligne de production Porsche.*

A Dream Project

If you have just a quick chat with Senior Design Manager for LEGO Technic, Andrew Woodman, you won't be in any doubt that this guy has a strong passion for sports cars—and not least the Porsche 911.

"To me it's fantastic to be able to combine my job and my interest for anything related to car design and performance, so when we started to discuss the idea for this new LEGO Technic concept, we were determined to create more than just a great building experience. We wanted every aspect of this concept to be special and drive a real desire in fans to own and build it.

"To do this we knew we needed a partner with the perfect vehicle that was both highly desirable and a true icon. We reached out to Porsche as we dreamt of having a Porsche 911 as our first model. From our very first meeting it was clear that Porsche shared the same passion for the vision of this concept and together we decided upon using the latest 911 GT3 RS as the first vehicle in this LEGO Technic series."

Un projet de rêve

Après une brève discussion avec le responsable principal du design de LEGO Technic, Andrew Woodman, il n'y a aucun doute que c'est un vrai passionné de voitures de sport, et notamment de la Porsche 911.

« C'est fantastique d'avoir la chance de combiner mon travail et mon intérêt pour tout ce qui est lié au design et à la performance de la voiture. Quand nous avons commencé à parler de ce nouveau concept LEGO Technic, nous étions déterminés à créer plus qu'une expérience de construction géniale. Nous voulions que chaque aspect de ce concept soit spécial et stimule un vrai désir chez les fans de le construire et de le posséder.

Pour cela, nous savions que nous avions besoin d'un partenaire ayant le véhicule parfait, qui soit à la fois hautement désirable et une véritable icône. Nous avons contacté Porsche car nous rêvions d'avoir comme premier modèle la Porsche 911. Dès notre toute première réunion, il était clair que Porsche avait la même passion pour la vision de ce concept et ensemble nous avons décidé d'utiliser la nouvelle 911 GT3 RS comme premier véhicule de cette série LEGO Technic. » ➔



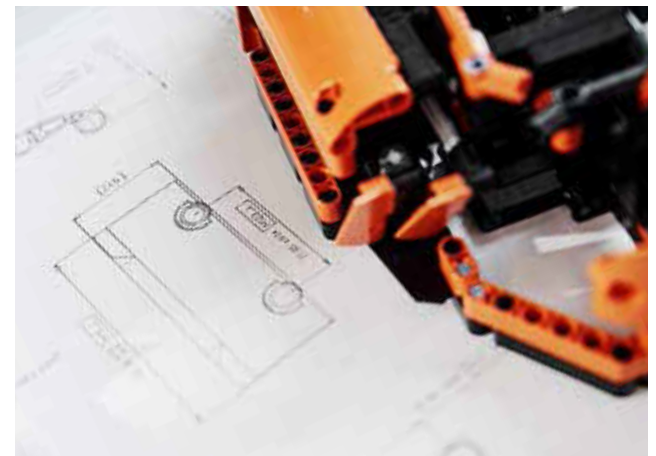

It's been fantastic working together with Porsche; the people we have met have shown a tremendous passion for the Porsche brand and a really deep interest in our LEGO Technic model.

ANDREW WOODMAN,
SENIOR DESIGN MANAGER, LEGO TECHNIC

Travailler avec Porsche a été fantastique, les personnes que nous avons rencontrées ont montré une immense passion pour la marque Porsche et un intérêt profond pour notre modèle LEGO Technic.

ANDREW WOODMAN,
RESPONSABLE PRINCIPAL DU DESIGN,
LEGO TECHNIC



➔ "Based only on images, we started the development of our first model. This was presented to the 911 GT3 RS design team at Porsche, who gave feedback on the important design features that define the iconic 911 shape.

"We developed the next model based on this feedback and also started the development of the wheels, which are an iconic part of the design of the car.

"About a month later we visited the 911 GT3 RS design team at the Porsche Development Center in Weissach. Here we presented our model to Andreas Preuninger, Head of GT Cars, and had a good discussion on the challenges of creating a 911 and specifically his team's 911 GT3 RS in LEGO elements. We had the opportunity to demonstrate all the technical features and got feedback on the functions Mr Preuninger wished to see in the model, and in which areas he felt the car's styling could be improved.

"Then we went to the Porsche GT workshop area to see a preproduction 911 GT3 RS complete and finished in lava orange. This was the first time we saw the car in color —all the others had been black, which Porsche uses intentionally to make it difficult to see the proportions and details of the car."

« Nous avons commencé le développement de notre premier modèle uniquement à partir d'images. Il a été présenté à l'équipe de conception de la 911 GT3 RS chez Porsche, qui a fait des commentaires sur les éléments de design importants qui définissent la célèbre forme de la 911.

Nous avons conçu le modèle suivant à partir de ces commentaires et nous avons aussi commencé le développement des roues qui sont une partie célèbre du design de la voiture.

Environ un mois plus tard, nous avons rendu visite à l'équipe de conception de la 911 GT3 RS au Centre de développement Porsche à Weissach. Nous avons alors présenté notre modèle à Andreas Preuninger, chef de la division des voitures GT, et nous avons eu une importante discussion sur les défis posés par la création d'une 911 avec des éléments LEGO, et plus particulièrement de la 911 GT3 RS de son équipe. Nous avons eu la possibilité de démontrer toutes les fonctions techniques et nous avons reçu des commentaires sur les fonctions que M. Preuninger souhaitait voir dans ce modèle, et sur les aspects de la voiture qui pouvaient être améliorés.

Nous sommes allés ensuite dans l'atelier des Porsche GT pour voir un modèle de présérie terminé de la 911 GT3 RS orange fusion. C'était la première fois que nous voyions la voiture en couleur. Toutes les autres étaient noires, il était donc plus difficile de voir les proportions et les détails de la voiture. »



The LEGO design team and Porsche 911 GT3 RS development team discuss the model at the Porsche Motorsport Center in Weissach. L'équipe de design LEGO et l'équipe de développement de la Porsche 911 GT3 RS parlent du modèle au Centre de sport automobile Porsche à Weissach.

« Back in Billund at LEGO Group HQ we started the development of the wing elements, as it became clear we needed a more defined outline to the wheel arch area of the car, both front and rear. This was one of our biggest challenges, as we needed to design an element to work on the 911 GT3 RS but also to be a LEGO Technic element that would work with all our other elements and be something that could work in our system for years to come.

“On returning from Porsche, the real hard work of the project began—the graphic designer started working on the required decorations and stickers, the model designer worked further on the styling using the new elements to great effect. This was an extremely difficult stage for the development of the gearbox and the designer went through many different versions before we ended up developing one last new element to make the gearbox run smoothly.

“The next big step was the final approval at Porsche. We got it. And after months of exciting work it was great to stand with such an accurate, function-filled model of one of the most iconic cars in the world—and to have it signed off by the designers and engineers of the real thing. A fantastic feeling all round.”

« De retour à Billund au siège social du Groupe LEGO, nous avons commencé le développement des ailes, car il était évident que nous avions besoin d'un contour plus défini de la zone du passage de roues de la voiture, à l'avant et à l'arrière. Cela a été l'un de nos plus grands défis, car nous devions concevoir un élément LEGO Technic qui conviendrait à la 911 GT3 RS mais qui fonctionnerait aussi avec tous nos autres éléments, de sorte que nous puissions l'utiliser pendant des années.

Après notre visite chez Porsche, le travail vraiment ardu sur le projet a commencé : le graphiste a commencé à travailler sur les décorations et les autocollants, et le designer de modèles a travaillé davantage sur le stylisme en utilisant les nouveaux éléments pour créer un excellent effet. Cette étape s'est avérée extrêmement difficile pour le développement de la boîte de vitesses. Le designer a créé de nombreuses versions différentes avant que nous ne finissions par développer un nouvel élément qui a permis à la boîte de vitesses de fonctionner correctement.

La grande étape suivante a été l'approbation finale de Porsche. Nous l'avons obtenue. Après des mois de travail passionnant, c'était fantastique d'avoir réalisé un modèle aussi précis et plein de fonctions de l'une des voitures les plus célèbres du monde, et qu'il soit approuvé par les concepteurs et les ingénieurs de la vraie voiture. C'était vraiment une sensation formidable. »



LEGO **TECHNIC**

Meetings with potential partners and development of preliminary sketch models.

Rencontres avec des partenaires potentiels et développement des premiers prototypes.

Start of design and prototyping of Porsche wheels.

Début du design et de la création des prototypes de roues Porsche.



Spring
Printemps
2014



Fall
Automne
2014

Winter
Hiver
2013



Development of the initial ideas around the concept.

Développement des idées initiales autour du concept.

Summer
Été
2014



First presentation of a very early model for Porsche in Stuttgart.

Première présentation d'un modèle préliminaire à Porsche, à Stuttgart.

Winter
Hiver
2014



First top-secret images of the 911 GT3 RS shared by Porsche.

Premières images ultra-secrètes de la 911 GT3 RS partagées par Porsche.

First sketch model images delivered to Porsche for feedback.

Premières images de prototype livrées à Porsche pour commentaires.



Winter
Hiver
2014

Development of new styling elements started including graphics, decorations, laser engraving and stickers.

Début du développement de nouveaux éléments esthétiques incluant des graphiques, des décorations, des gravures au laser et des autocollants.



Spring
Printemps
2015

Meeting with Andreas Preuninger and his team for final approval of model.

Réunion avec Andreas Preuninger et son équipe pour une approbation finale du modèle.



Fall
Automne
2015

Spring
Printemps
2015



First meeting with Andreas Preuninger and his team at the Porsche Development Center.

Première réunion avec Andreas Preuninger et son équipe au Centre de développement Porsche.

Summer
Été
2015



Building, testing and re-building of the model with LEGO model quality team and building instructions designers.

Construction, test et reconstruction du modèle avec l'équipe de la qualité LEGO et les concepteurs des instructions de montage.



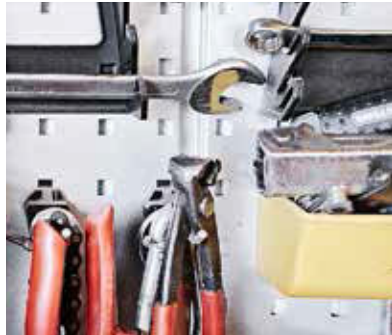

Senior LEGO Designer Uwe Wabra.
Uwe Wabra, designer principal LEGO.



A Passion for Detail

A quick look at Senior LEGO Designer Uwe Wabra's own garage clearly shows that this is someone who is into anything mechanical that can be taken apart and assembled again. Cars, motorbikes, mopeds, bicycles—pretty much everything that is mechanical and on wheels. Mix his hobbies with his 19 years of experience as a LEGO product designer, and it's easy to see why the Porsche 911 GT3 RS project landed on his desk in the LEGO Technic designer team.

"It was fantastic to get the opportunity to work on the Porsche project, but also a real challenge. As Porsche's 911 GT3 RS project was still top secret at the time, I had to build the first Technic version from 'spy-photos' from the Internet.

"I did the first prototype in a matter of weeks. We then took it to Porsche and got great feedback from the 911 GT3 RS team on both the

La passion du détail

Un coup d'œil rapide au garage du designer principal LEGO, Uwe Wabra, montre qu'il adore tout ce qui est mécanique et qui peut être démonté et assemblé à nouveau. Les voitures, les motos, les mobylettes, les vélos : tout ce qui est mécanique et sur roues. Mélangez sa passion et ses 19 ans d'expérience comme designer de produits LEGO et il est facile de voir pourquoi le projet de la Porsche 911 GT3 RS a atterri sur son bureau dans l'équipe de designers LEGO Technic.

« Cela a été fantastique d'avoir l'occasion de travailler sur le projet Porsche, mais aussi un vrai défi. Comme le projet de la Porsche 911 GT3 RS était ultra-secret à l'époque, j'ai dû construire la première version Technic avec des "photos d'espionnage" sur Internet.

J'ai réalisé le premier prototype en quelques semaines. Nous l'avons ensuite montré à Porsche et nous avons reçu des



- technical details and the overall design. That's also when I saw the real 911 GT3 RS for the first time. I was very inspired by its minimalistic, brutal design and left Stuttgart even more eager to take our model to the next level.

"I really wanted to incorporate as many of the unique design details from the real car as possible, especially the shape of the bonnet and roof, the air-intakes and not least the low, sloping angle of the car.

"It was also important to integrate as many of the advanced technical functionalities from the real 911 GT3 RS as we could. The steering and suspension were difficult enough, but the biggest challenge was to create the functioning paddle-shift PDK gearing system.

"I am really proud of the finished model—it's great that we managed to give the LEGO Technic model the genuine 911 silhouette design-line and add so many advanced technical features." ✖

commentaires excellents de l'équipe 911 GT3 RS sur les détails techniques et le design général.

C'est aussi à ce moment que j'ai vu la vraie 911 GT3 RS pour la première fois. J'ai été très inspiré par son design minimaliste et brutal et j'ai quitté Stuttgart encore plus déterminé à rendre notre modèle plus spécial.

Je voulais vraiment intégrer autant de détails que possible du design unique de la vraie voiture, en particulier la forme du capot et du toit, les prises d'air et aussi l'angle bas et en pente de la voiture.

Il était aussi très important d'intégrer autant des fonctionnalités techniques avancées de la vraie 911 GT3 RS que possible. La direction et la suspension étaient assez complexes, mais le plus grand défi a été de créer le système de changement de vitesse PDK qui fonctionne.

Je suis vraiment fier du modèle final : il est formidable que nous ayons réussi à donner au modèle LEGO Technic la vraie silhouette de la 911 et à ajouter de si nombreuses fonctionnalités techniques. » ✖

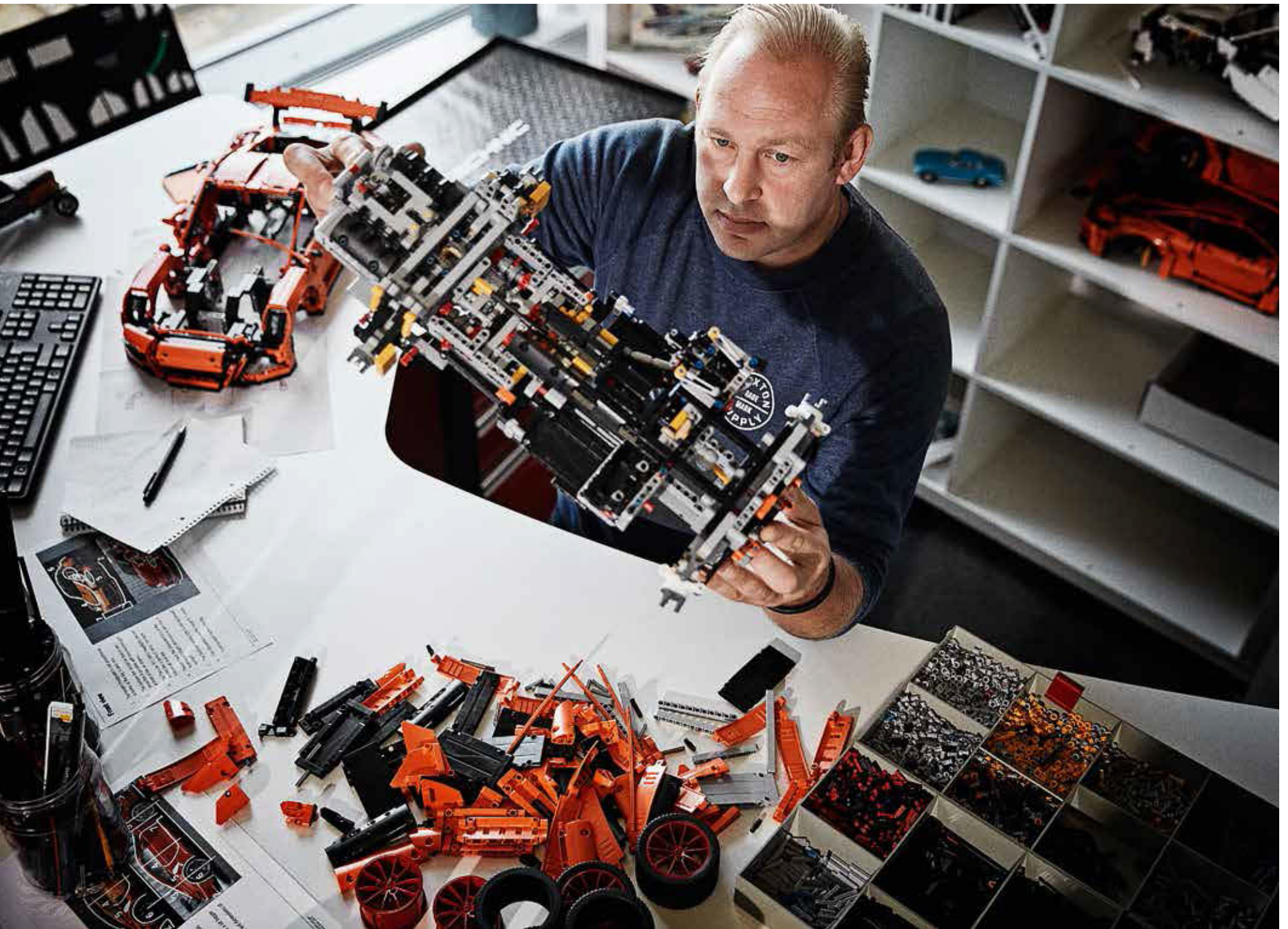



Dr. Frank-Steffen Walliser, VP Motorsports and GT Cars at Porsche with his first LEGO Technic model from 1980.

Dr Frank-Steffen Walliser, vice-président de la division du sport automobile et des voitures GT chez Porsche, avec son premier modèle LEGO Technic de 1980.

A LEGO® Memory

"This is *exactly* the one," is the immediate comment from Dr. Frank-Steffen Walliser, VP Motorsports and GT Cars at Porsche. Just returned from a victorious Porsche race weekend in the US, Dr. Walliser is pointing at an early LEGO Technic model launched in 1980 that's placed on his desk in his office.

"LEGO was a big part of my childhood. I had several LEGO models and I think I got this specific one as a Christmas present when I was about 11 years old. I still remember all its details and technical features," says Dr. Walliser, while proving his LEGO knowledge by discretely pointing out that one of the wheels on the model has been mounted the wrong way round.

"I actually made a small mistake when assembling the boxer engine. I couldn't make the pistons work properly even though I took the model apart and assembled it over and over again. My friend had the same model and his worked perfectly fine so I knew it could and should work smoothly. It nagged me for months until I got hold of the model again and finally made it work as it was supposed to.

"This LEGO Technic model was part of defining my interest in cars and later, as a teenager, helped push my education and career in the direction of technical engineering."

Un souvenir LEGO®

Le premier commentaire du Dr Frank-Steffen Walliser, vice-président de la division du sport automobile et des voitures GT chez Porsche, a été : « c'est exactement celui-là ». De retour d'un week-end de course victorieux pour Porsche aux États-Unis, le Dr Walliser montre un ancien modèle LEGO Technic lancé en 1980 qui est placé sur la table de son bureau.

« LEGO a occupé une place importante dans mon enfance. J'avais plusieurs modèles LEGO et je pense que j'ai eu celui-ci comme cadeau de Noël quand j'avais environ 11 ans. Je me souviens encore de tous ses détails et de ses fonctions techniques », déclare le Dr Walliser, tout en prouvant ses connaissances LEGO en faisant discrètement remarquer que l'une des roues du modèle a été montée à l'envers.

« J'ai en fait commis une petite erreur quand j'ai assemblé le moteur boxer. Je n'arrivais pas à faire fonctionner les pistons correctement, même en démontant et en remontant le modèle encore et encore. Un ami avait le même modèle et il fonctionnait parfaitement, je savais donc qu'il pouvait et devait fonctionner. Cela m'a ennuyé pendant des mois jusqu'à ce que je reprenne le modèle et réussisse à le faire fonctionner normalement.

Ce modèle LEGO Technic a contribué à définir mon intérêt pour les voitures, et plus tard, quand j'étais adolescent, cela a aidé à pousser mon éducation et ma carrière en direction de l'ingénierie technique. »

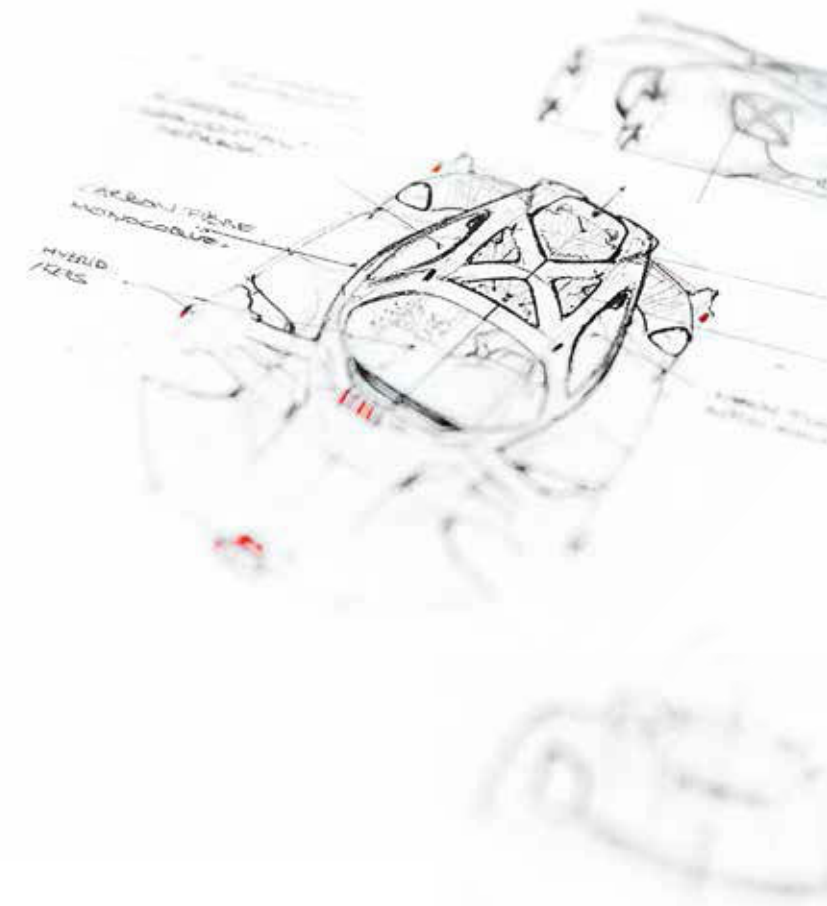

➤ "I am glad to see how my own kids have picked up on LEGO and LEGO Technic. My son got his first Technic set around the age of six. He is completely into it and I like the fact that it helps his understanding of how things function mechanically.

"We have a standard procedure when the kids and I begin building a new LEGO set. We sit down, closely study the box and the building instructions, and then we start sorting the bricks by color, form and function. After that we start the actual building. For us the building of the model is play in itself.

"Looking at the LEGO Technic Porsche 911 GT3 RS model, I'm impressed that they have managed to create the distinct curved lines of the Porsche 911. I know how difficult it is to shape the softer lines with LEGO elements.

"It is great to experience the level of detail and all the working parts in the model. The functioning PDK gear is especially impressive. And I like that everything is there, even if it is eventually hidden away—just like in the real car.

"At Porsche, a car is not just a car: it's all about the design, the performance, the sense of detail and, not least, the passion and dedication. I really feel that those things are here when you look at the LEGO model." ✖

« Je suis heureux de voir que mes propres enfants aiment LEGO et LEGO Technic. Mon fils a eu son premier ensemble Technic vers l'âge de six ans. Il adore ça et j'aime le fait que cela aide sa compréhension du fonctionnement mécanique des choses.

Nous procédons toujours de la même façon les enfants et moi quand nous commençons à construire un nouvel ensemble LEGO. Nous nous assoyons, nous étudions la boîte et les instructions de montage et nous commençons à trier les briques par couleur, forme et fonction. Ensuite, nous commençons la construction. Pour nous, la construction du modèle est déjà un jeu.

En regardant le modèle LEGO Technic de la Porsche 911 GT3 RS, je suis impressionné qu'ils aient réussi à créer les lignes courbes caractéristiques de la Porsche 911. Je sais à quel point il est difficile de former des lignes plus douces avec des éléments LEGO.

Il est fantastique de découvrir le niveau de détail et toutes les parties du modèle qui fonctionnent. La boîte de vitesses PDK qui fonctionne est particulièrement impressionnante. Et j'aime le fait que tout soit là, même si cela est éventuellement caché, tout comme dans la vraie voiture.

Chez Porsche, une voiture n'est pas juste une voiture : tout est dans le design, la performance, le sens du détail et surtout, la passion et la détermination. Je sens vraiment que toutes ces choses sont là quand on regarde le modèle LEGO. » ✖

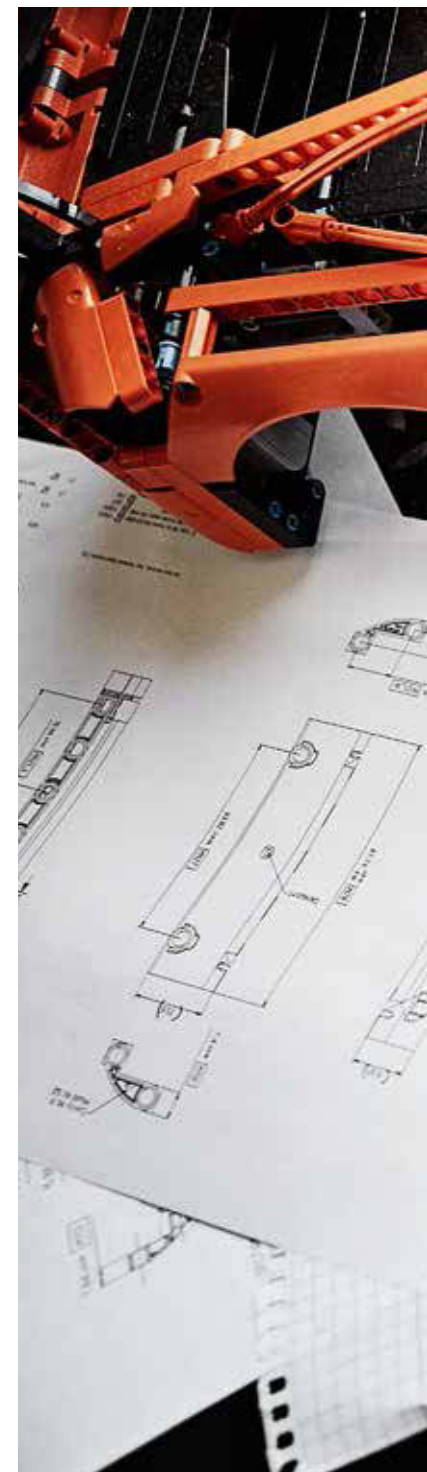





Wolfgang Reiß, Plant Manager, Porsche.
Wolfgang Reiß, directeur d'usine, Porsche.



Producing Excellence

With more than 25 years of experience at Porsche, and the last three years as Plant Manager, Wolfgang Reiß is the most knowledgeable person to explain the challenges of constructing a car like the Porsche 911 GT3 RS.

"It's a special car and it takes a number of unique processes to ensure that the 2700 larger individual elements that go into the 911 GT3 RS come precisely together," says Mr Reiß. He explains that it takes four full days to assemble a Porsche 911 GT3 RS on the production line at the factory in Stuttgart and that the car will pass through the skilled hands of more than 600 specialists as it is assembled.

La production de l'excellence

Avec plus de 25 ans d'expérience chez Porsche, dont les trois dernières années en tant que directeur d'usine, Wolfgang Reiß est la personne la mieux placée pour expliquer les défis de la construction d'une voiture comme la Porsche 911 GT3 RS.

« C'est une voiture spéciale et il faut plusieurs processus uniques pour nous assurer que les 2700 grands éléments individuels que comprend la 911 GT3 RS s'assemblent avec précision », déclare M. Reiß. Il explique qu'il faut quatre journées entières pour assembler une Porsche 911 GT3 RS sur la ligne de production de l'usine de Stuttgart et que la voiture passe entre les mains expertes de plus de 600 spécialistes lorsqu'elle est assemblée.

Interrogé sur les problèmes spécifiques qu'ils ont avec le processus de construction de la 911 GT3 RS, M. Reiß souligne le ➔

Asked to describe the specific issues they have with the 911 GT3 RS construction process, Mr Reiß highlights the luggage compartment lid, spoiler and especially the fenders as unique for this model, and the rollover bar as an option.

"Normally the complete body of the car is assembled with fenders for spraying. With the 911 GT3 RS the special fenders, with their integrated outlets, are not fitted to the body during the paint shop. This gives us a special challenge later when trying to ensure a uniform gap between the door and fender.

"The so-called 'marriage' is the magic moment in the Porsche production process. It's where the heart of the car—the engine—is mounted to rest on the drivetrain and the body is lowered for final assembly. It's a piece of logistic excellence to have these central components meet and merge at one spot on the assembly line within a matter of seconds."

Asked for his reaction on seeing the LEGO Technic version of the 911 GT3 RS for the first time, Mr Reiß states, "It's clear our two companies share the same dedication to detail. It's exciting to see how far LEGO has developed since my brother and I built simple cars with LEGO when we were young boys over 40 years ago." 🚗

capot du compartiment à bagages, l'aile et surtout les ailes comme uniques pour ce modèle, et l'arceau en option.

« Normalement, la carrosserie complète de la voiture est assemblée avec les ailes pour la peinture. Avec la 911 GT3 RS, les ailes spéciales avec leurs prises d'air intégrées ne sont pas montées sur la carrosserie pendant la peinture. Ceci nous donne un défi spécial par la suite pour assurer un écart uniforme entre la porte et l'aile.

Ce soi-disant "mariage" est le moment magique du processus de production Porsche. C'est alors que le cœur de la voiture, le moteur, est monté sur le reste du système de transmission et que la carrosserie est abaissée pour un assemblage final. C'est une grande réussite logistique de faire en sorte que ces composants centraux se réunissent et s'assemblent en quelques secondes à un seul endroit de la chaîne de montage. »

Interrogé sur sa réaction quand il a vu la version LEGO Technic de la 911 GT3 RS pour la première fois, M. Reiß a déclaré : « Il est évident que nos deux sociétés partagent la même passion du détail. Il est fascinant de voir à quel point LEGO s'est développé depuis que mon frère et moi construisions de simples voitures LEGO quand nous étions de jeunes garçons, il y a plus de 40 ans. » 🚗





Get Ready To Build

Having read all about this special car and learned how LEGO designers work, it is now time to build your LEGO Technic version of the Porsche 911 GT3 RS. We hope you will enjoy the challenge...

Place à la construction

Après avoir tout lu sur cette voiture spéciale et appris comment les designers LEGO travaillent, le moment est venu de construire votre version LEGO Technic de la Porsche 911 GT3 RS. Nous espérons que ce défi vous plaira...





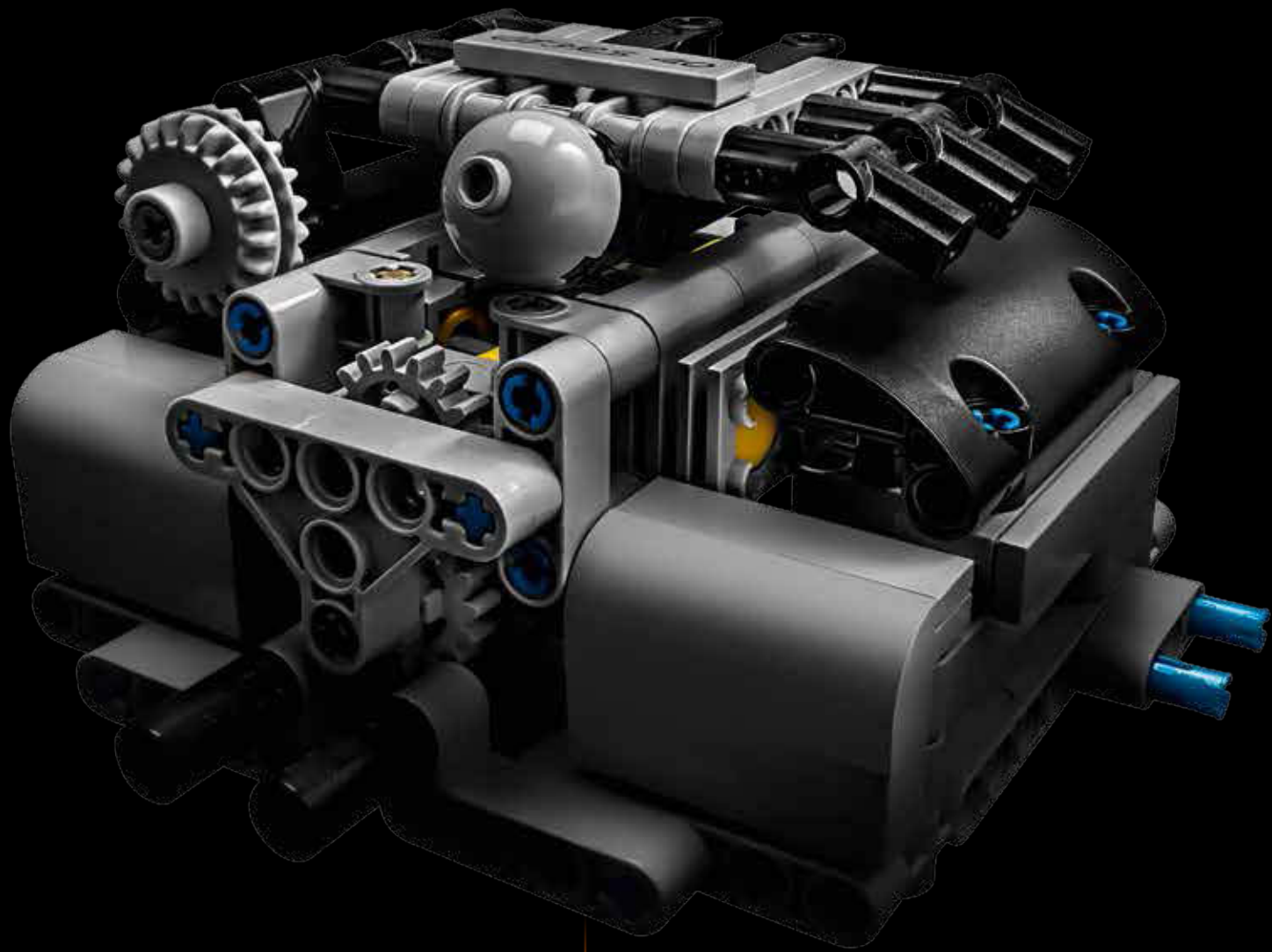

1

The first step in the construction of your 911 GT3 RS is to build the drivetrain, complete with dual clutch gearbox (PDK), paddle shifters, suspension and the heart of the 911 GT3 RS, the 4.0 flat 6 engine. When you have completed all the steps in box 1 you will be able to test out all the functions and see how they work.

La première étape dans la construction de la 911 GT3 RS est de construire le système de transmission, avec la boîte de vitesse à double embrayage, le système de changement de vitesse PDK et le cœur de la 911 GT3 RS : le moteur 6 cylindres à plat 4.0. Lorsque vous aurez terminé toutes les étapes de la boîte 1, vous pourrez tester toutes les fonctions et voir comment elles fonctionnent.

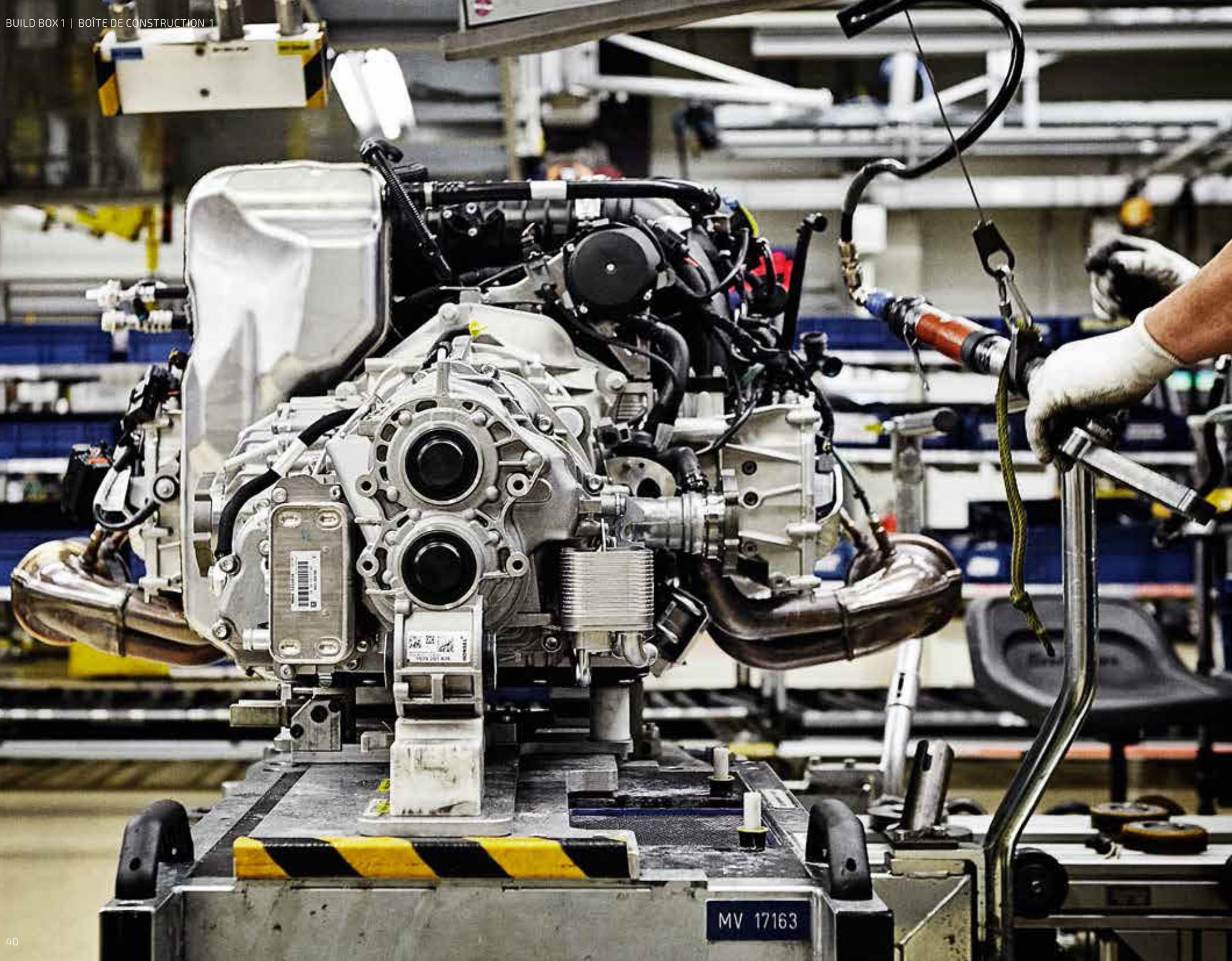

MV 17163

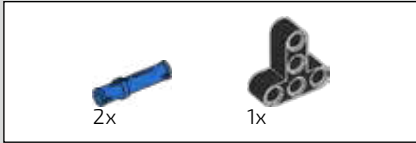

1

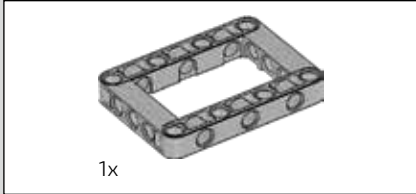
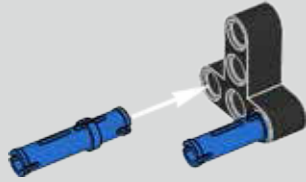

2

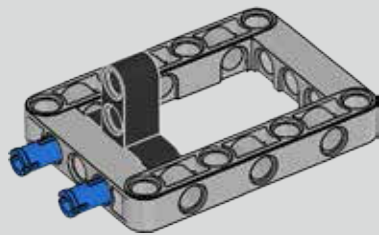

3

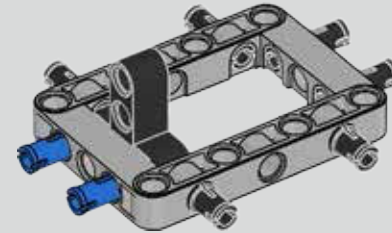

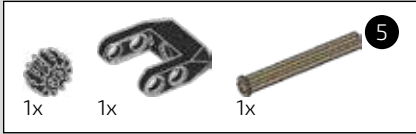

4

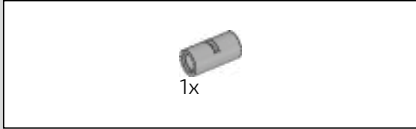
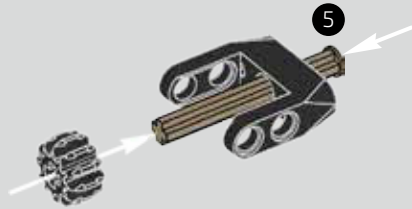

5

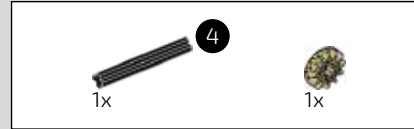
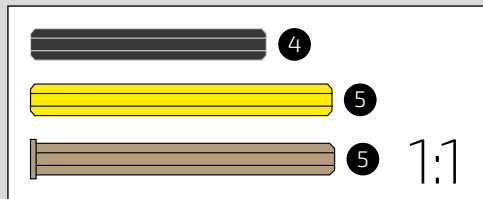
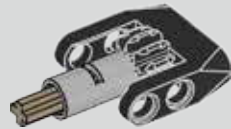

6

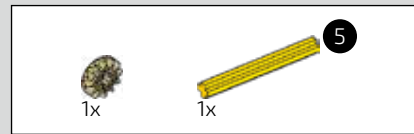
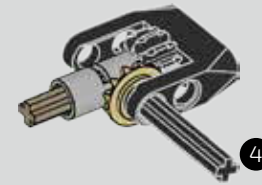

7

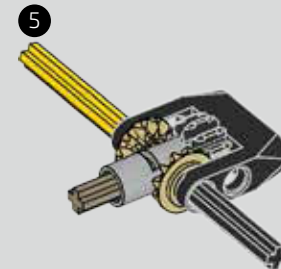

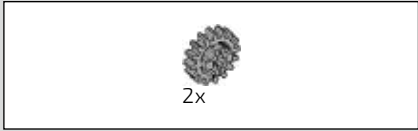

8

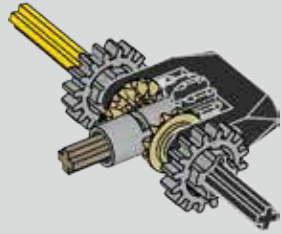

9

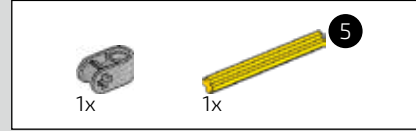
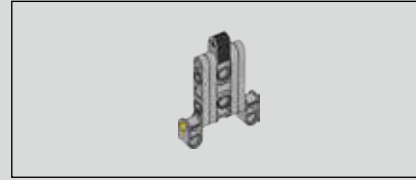
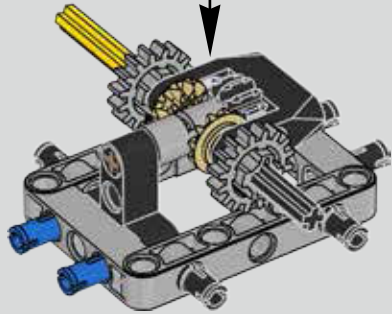

10

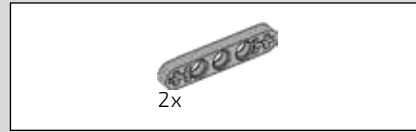
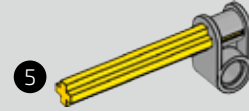

11

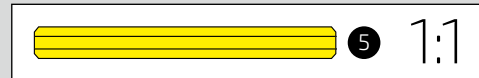
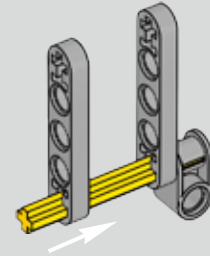

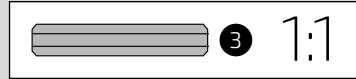
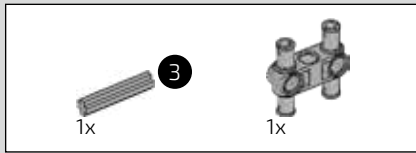

12

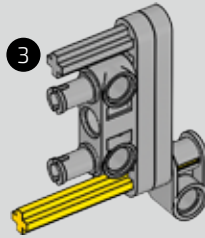

13

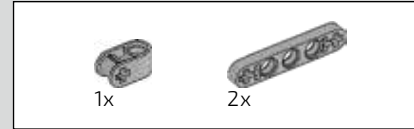
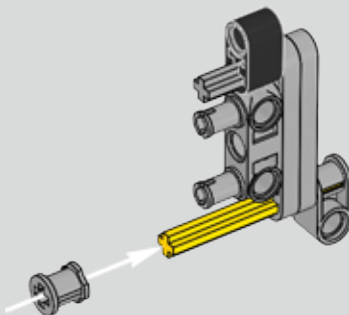

14

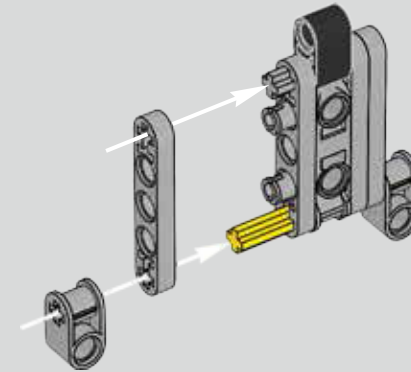

15

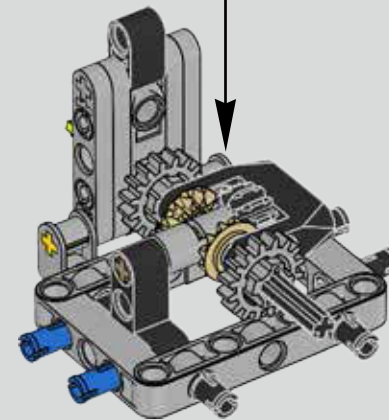



16

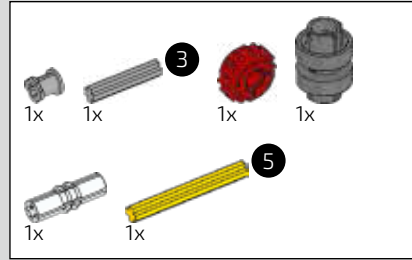
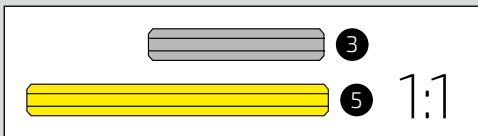
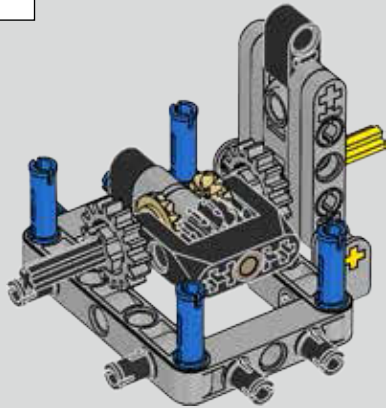
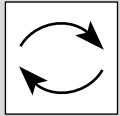

17

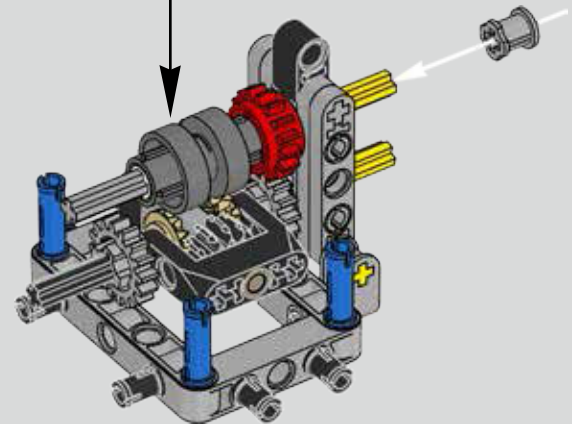
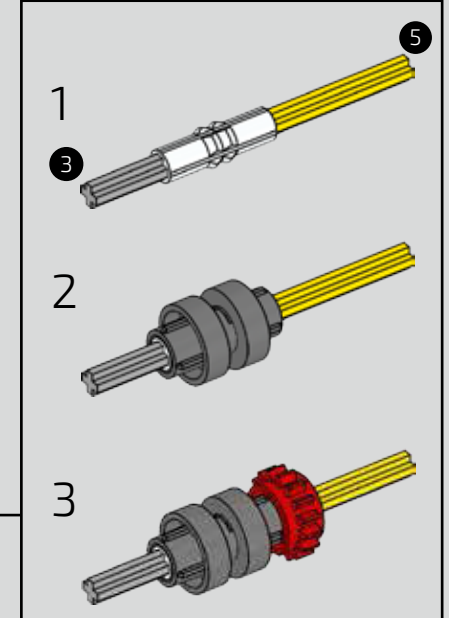

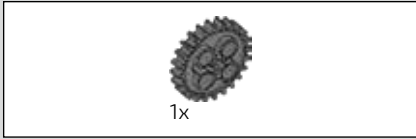

18

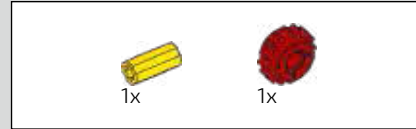
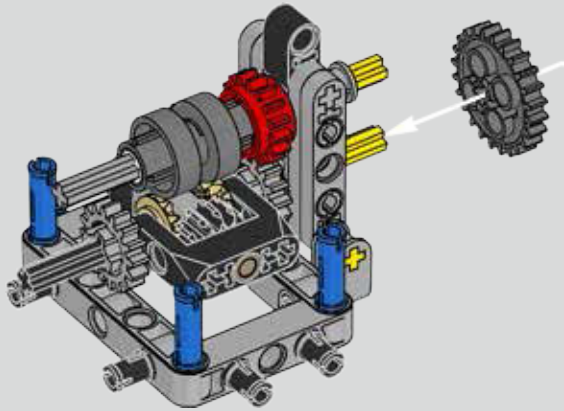

19

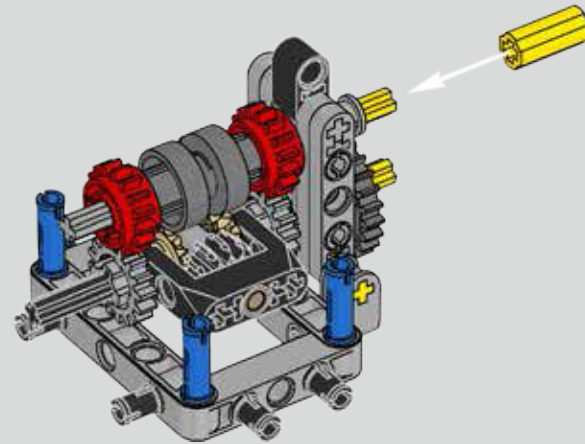

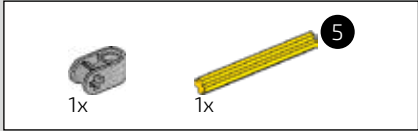
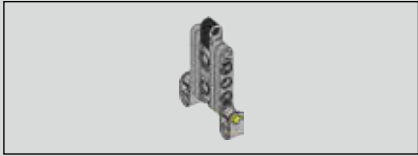

20

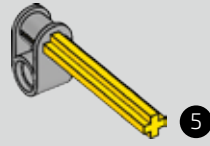

21

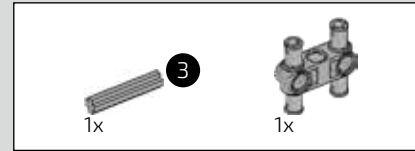
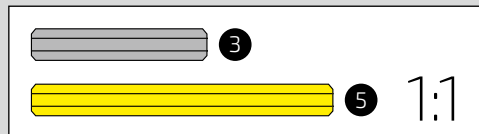
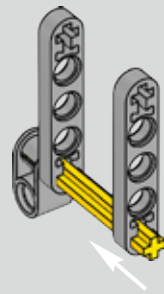

22

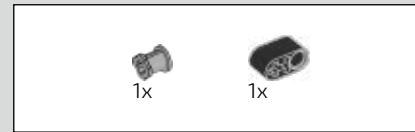
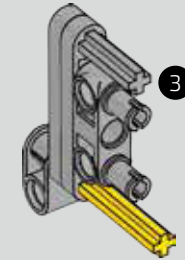

23

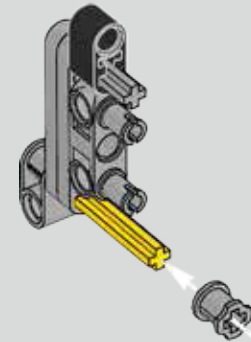



24

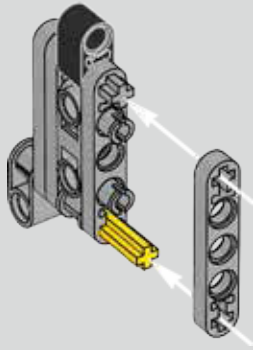

25

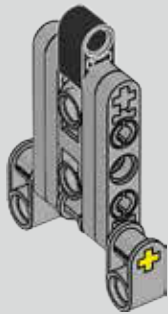

26

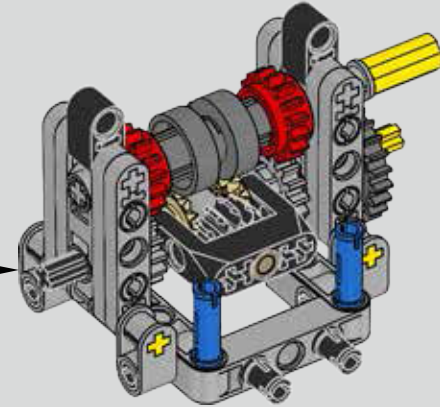

27

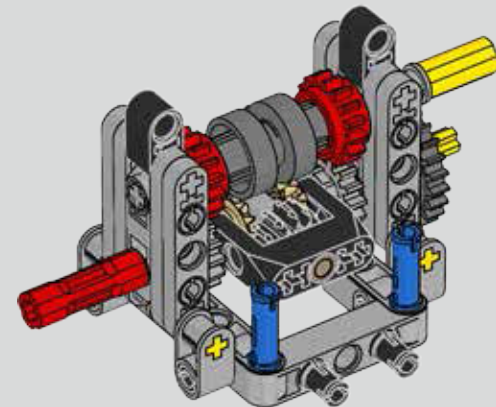

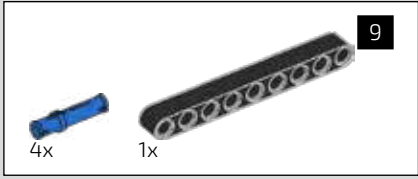

28

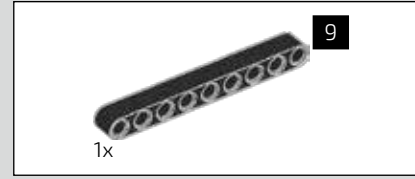
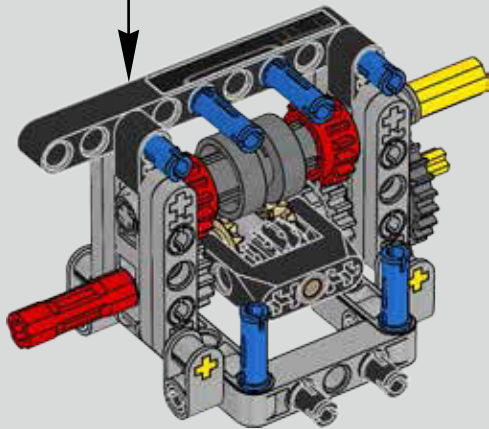
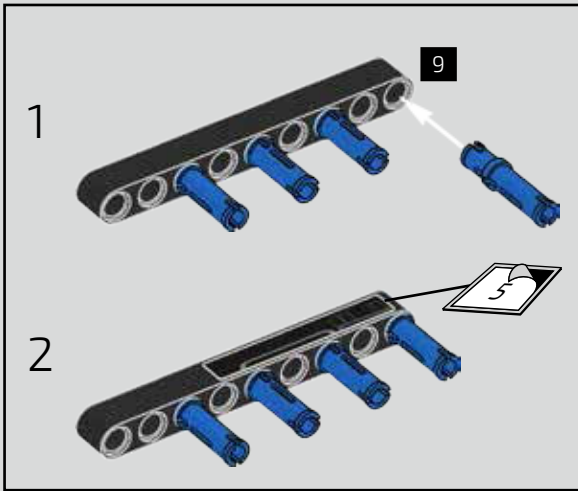

29

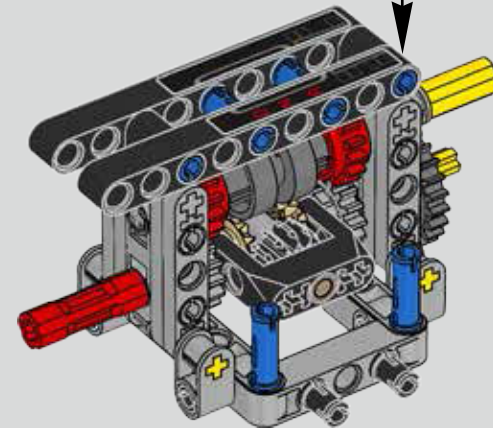
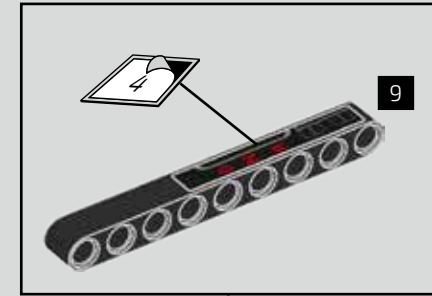

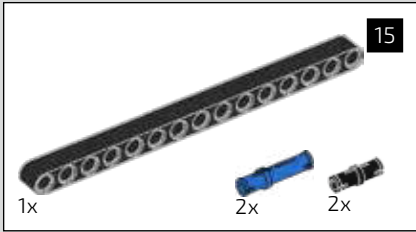
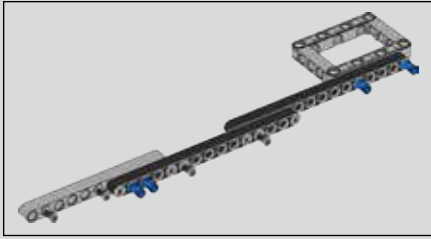

30

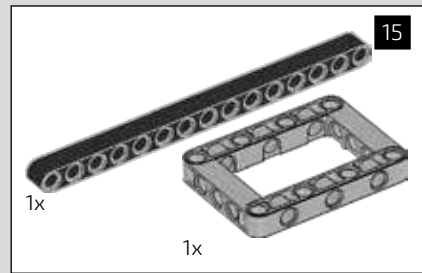
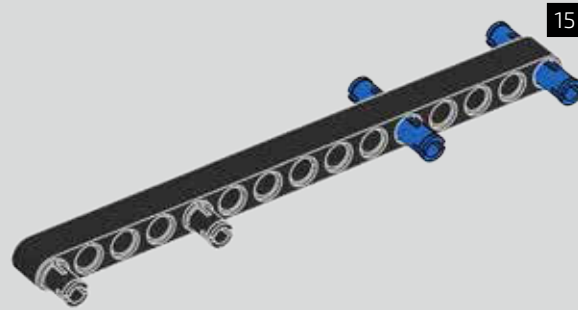

31

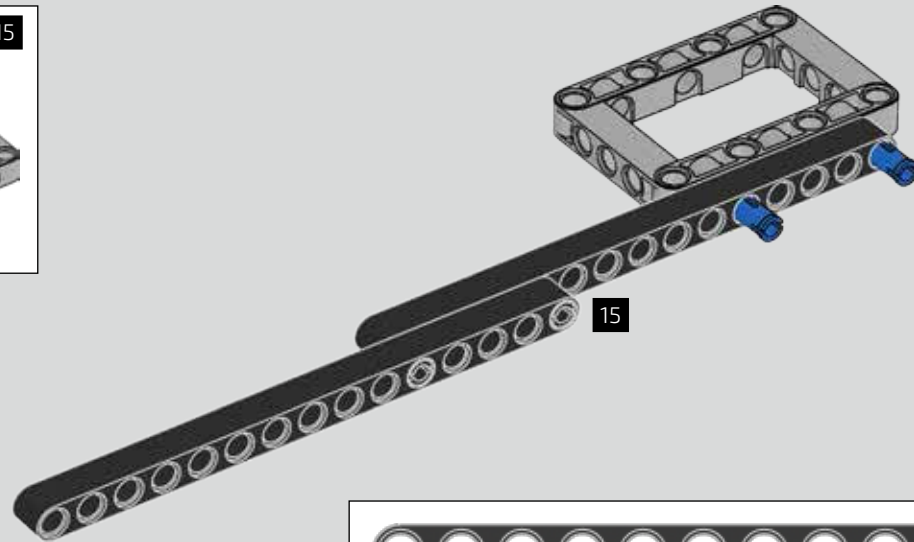



32

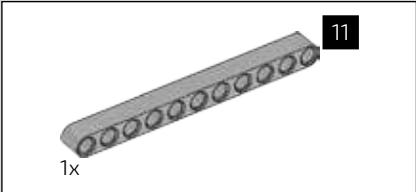
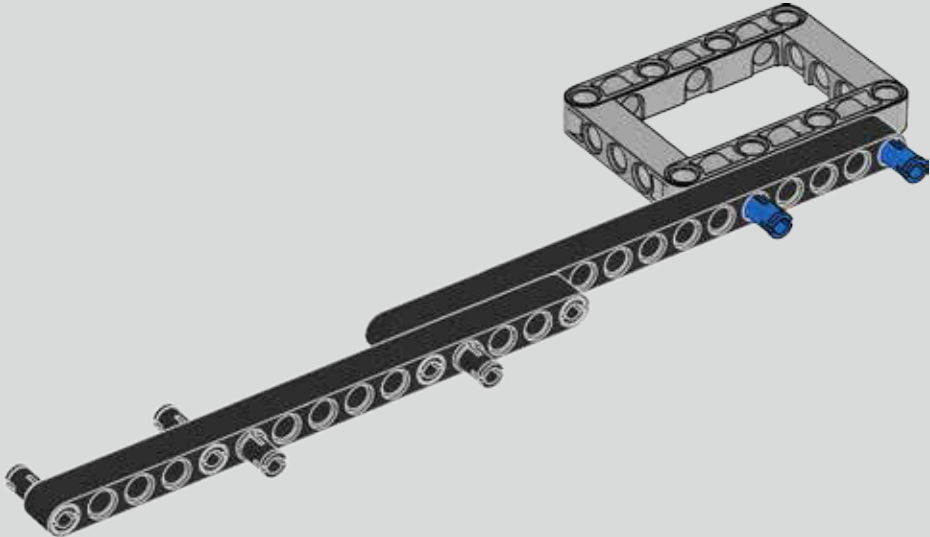

33

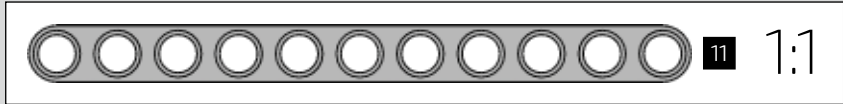
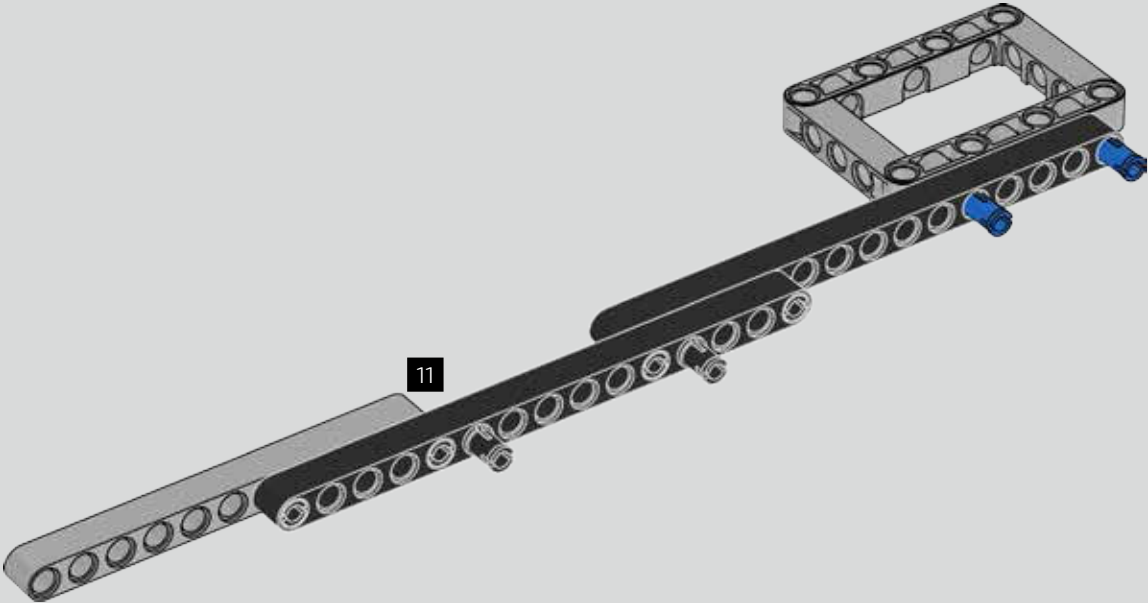

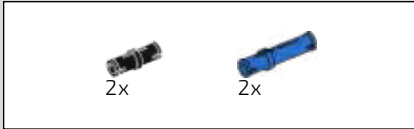

34

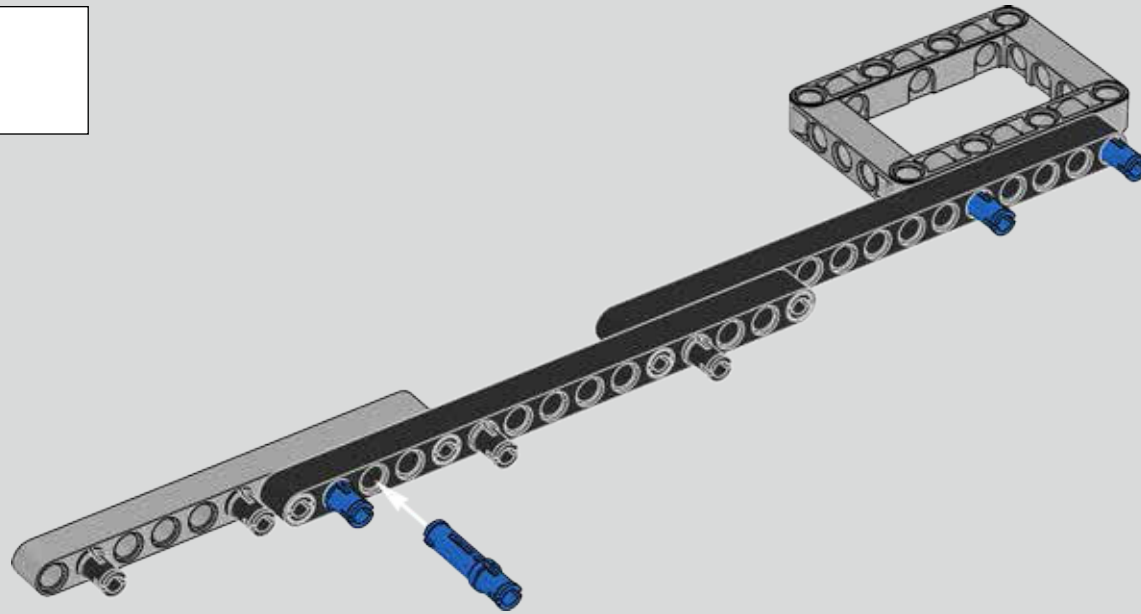

35

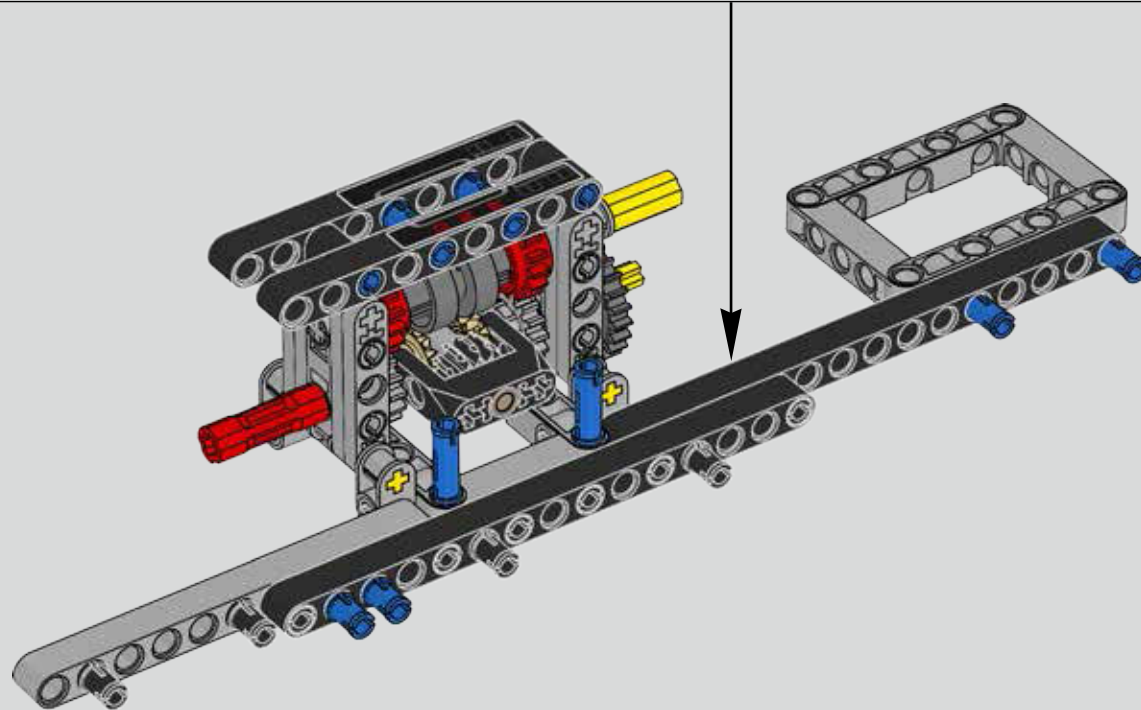

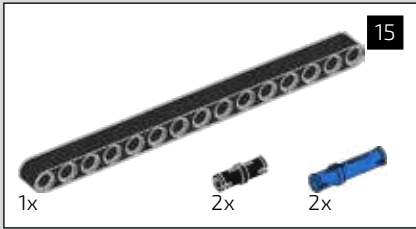
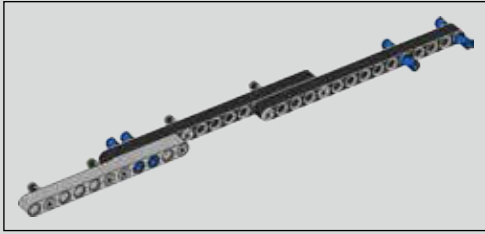

36

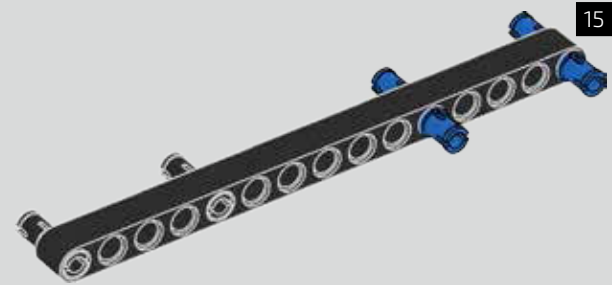

37

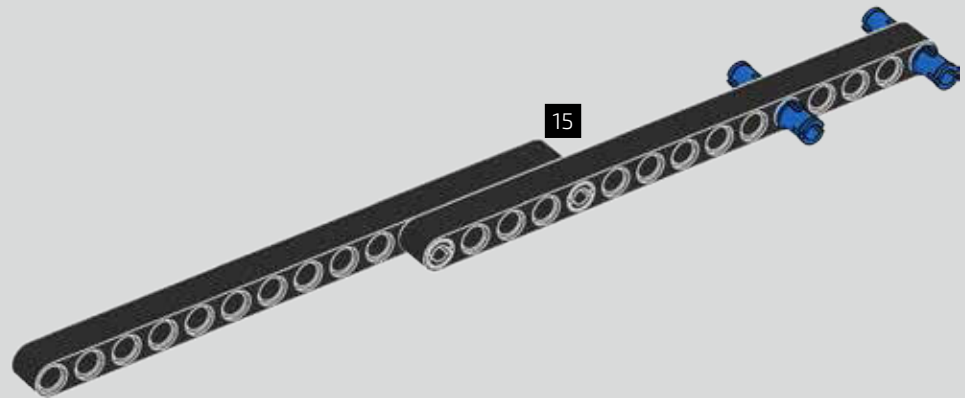



38

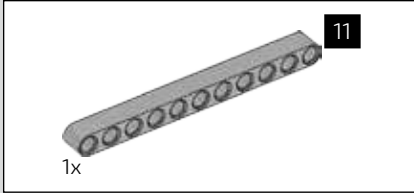
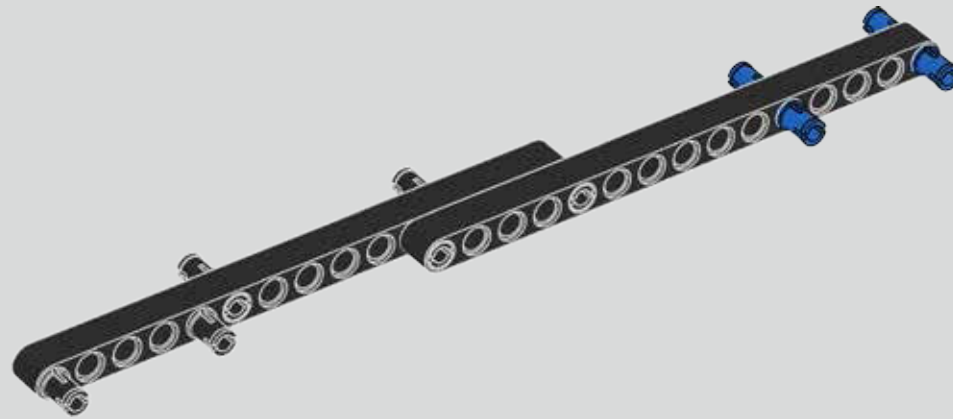

39

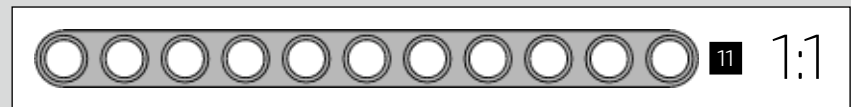
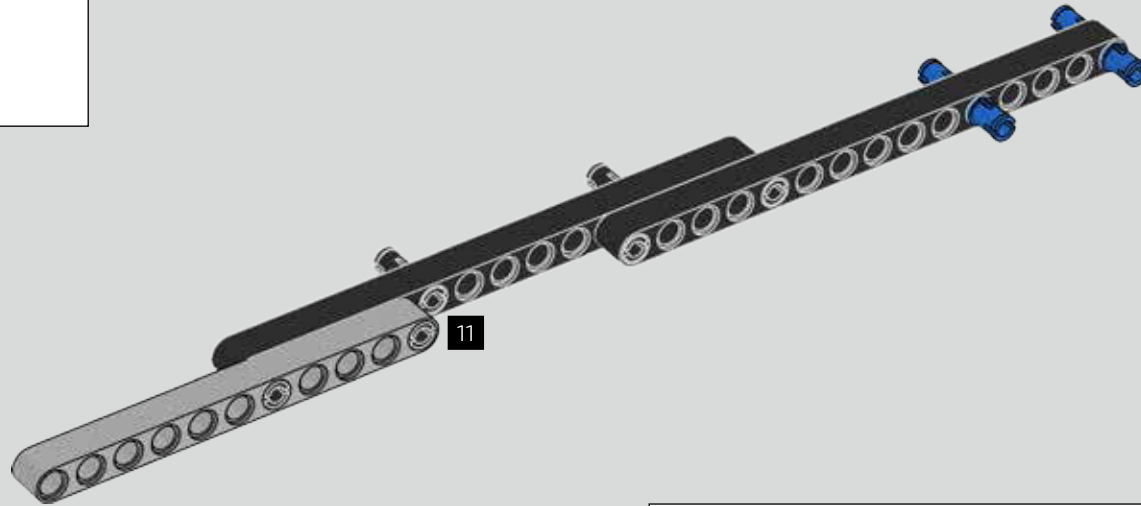

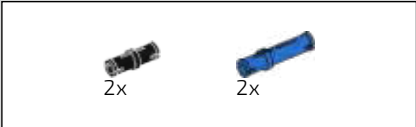

40

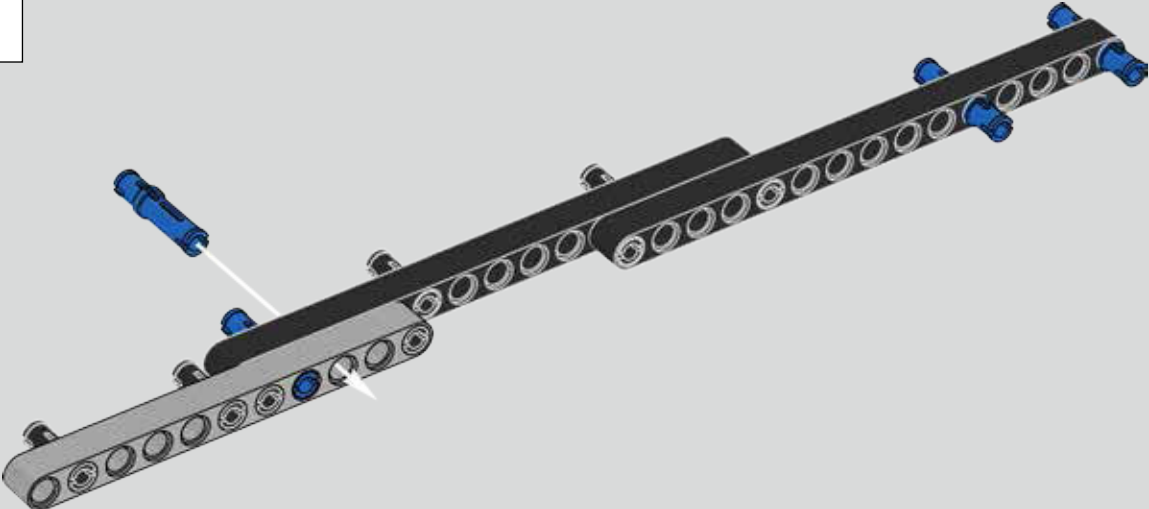

41

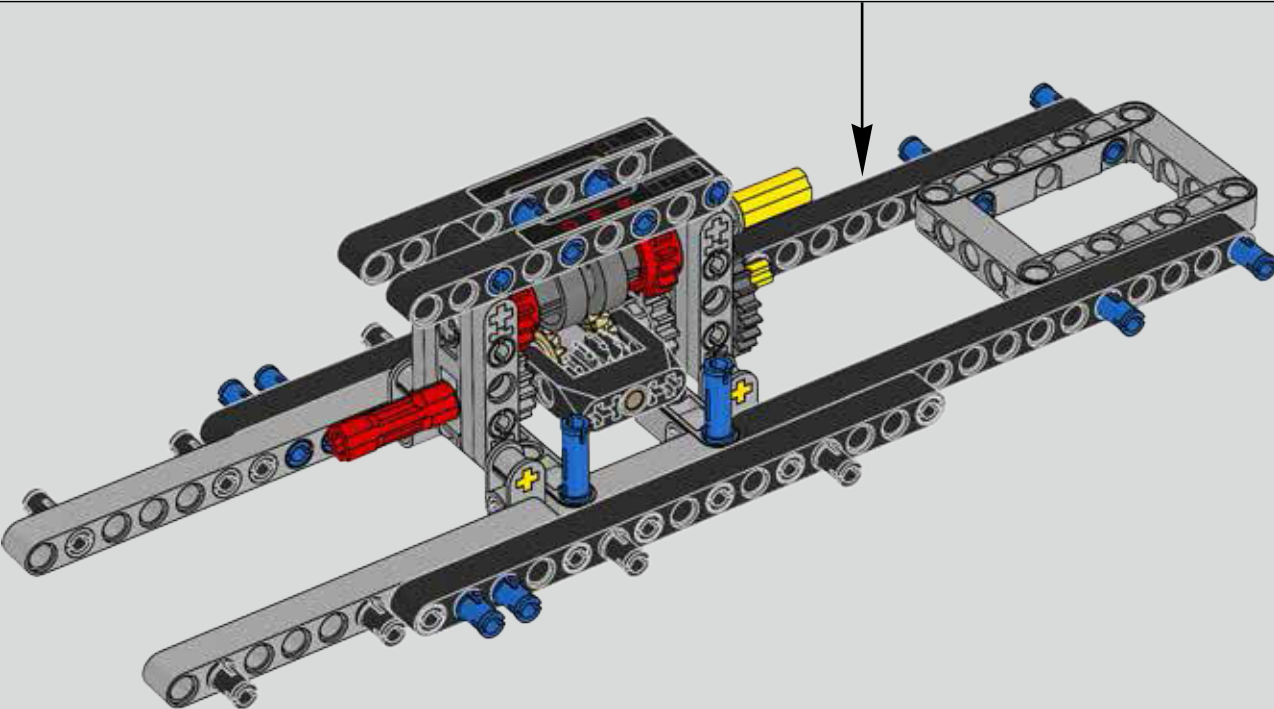

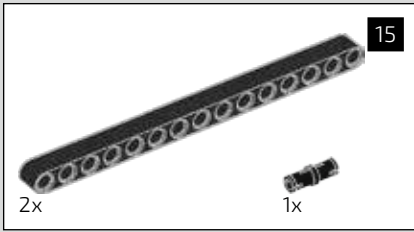

42

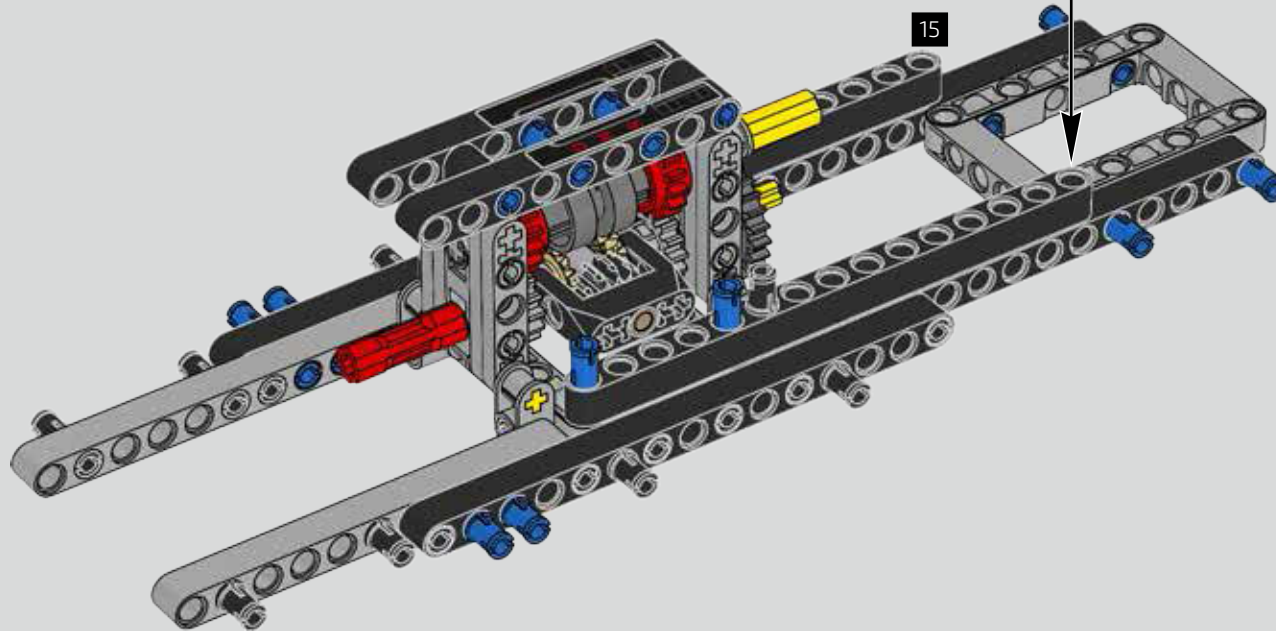
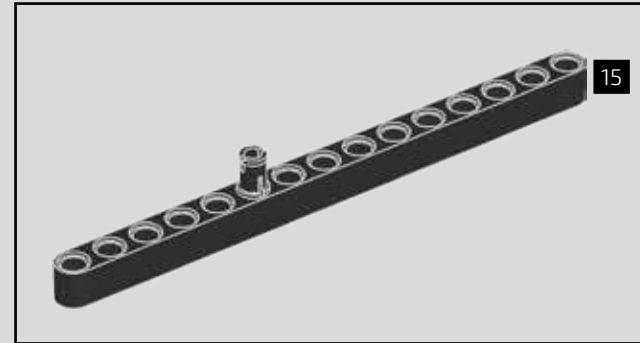

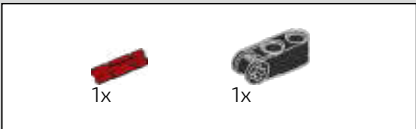

43

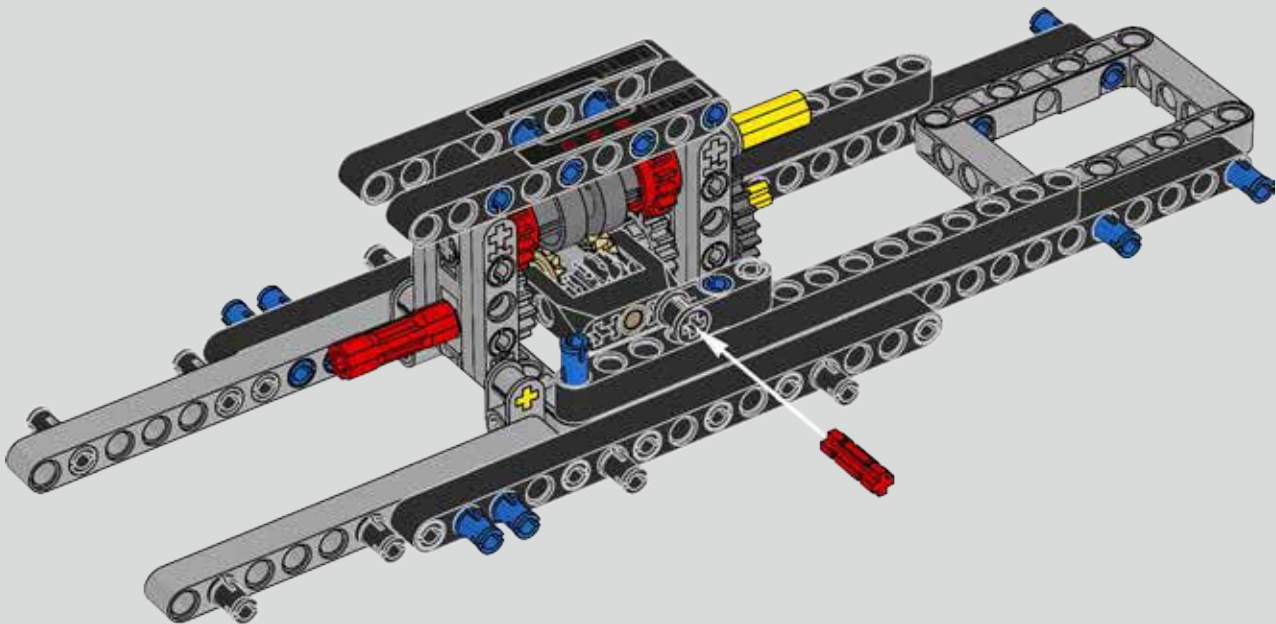



44

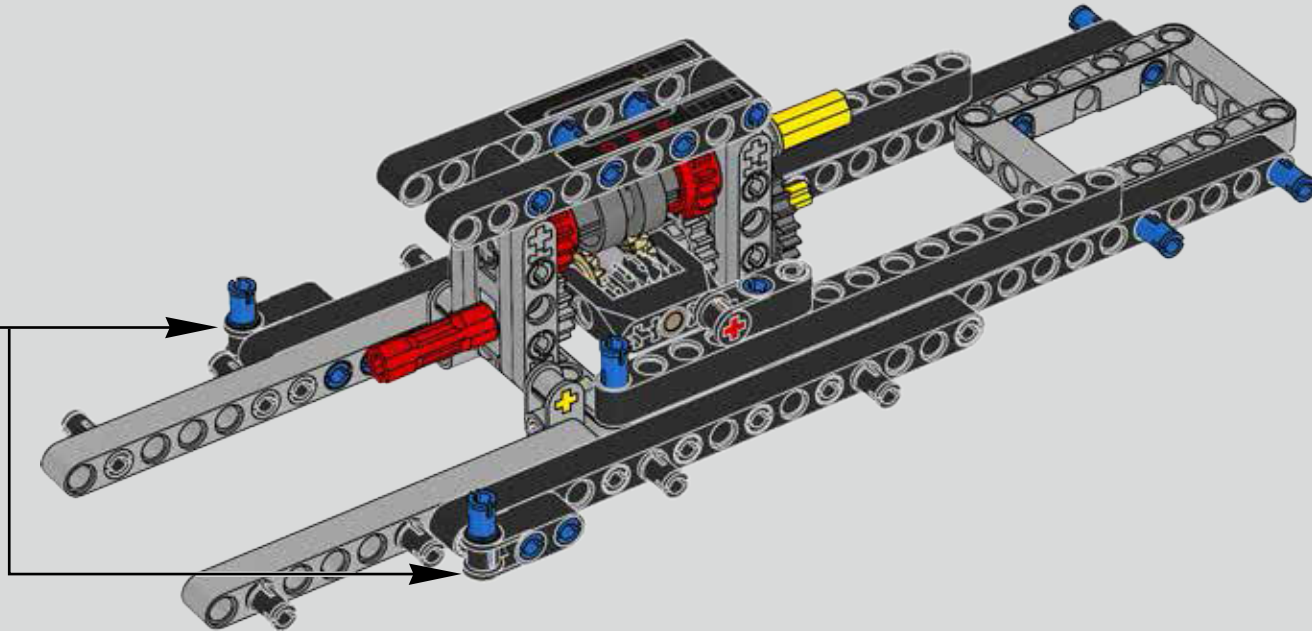
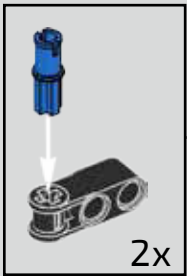

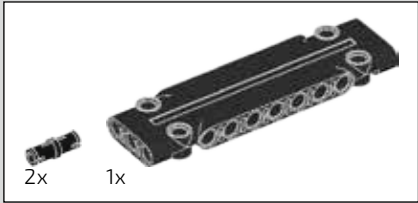
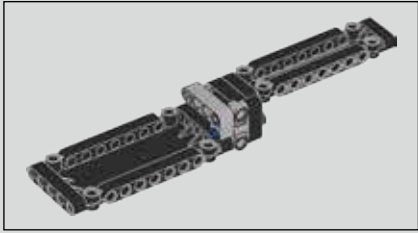

45

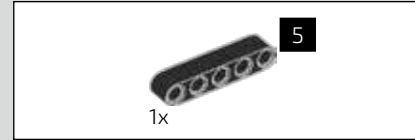
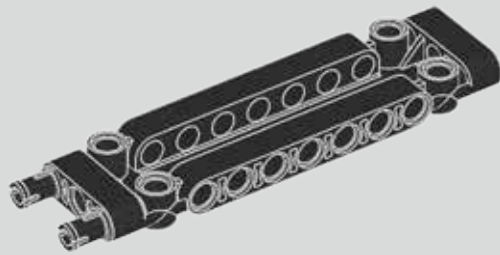

46

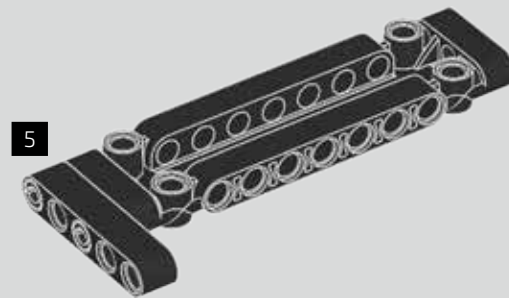

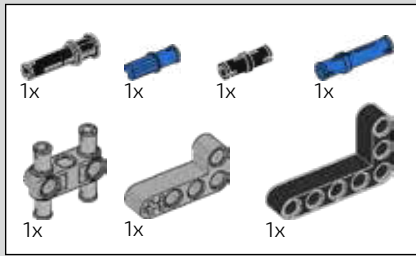

47

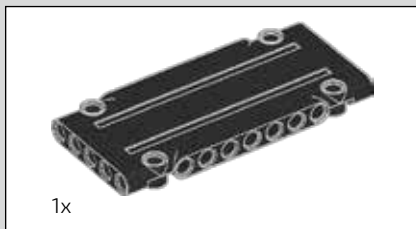
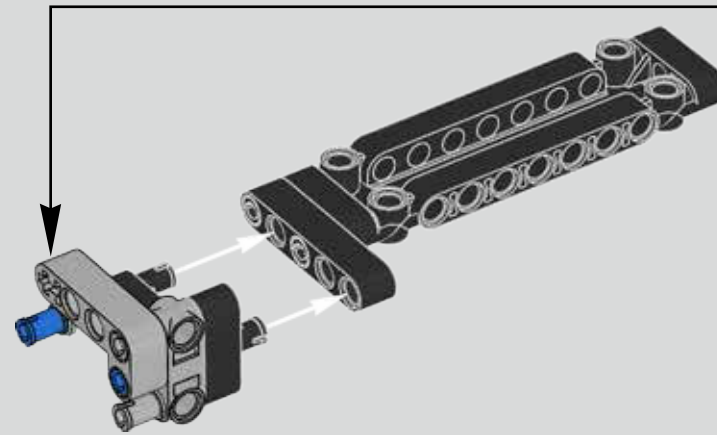
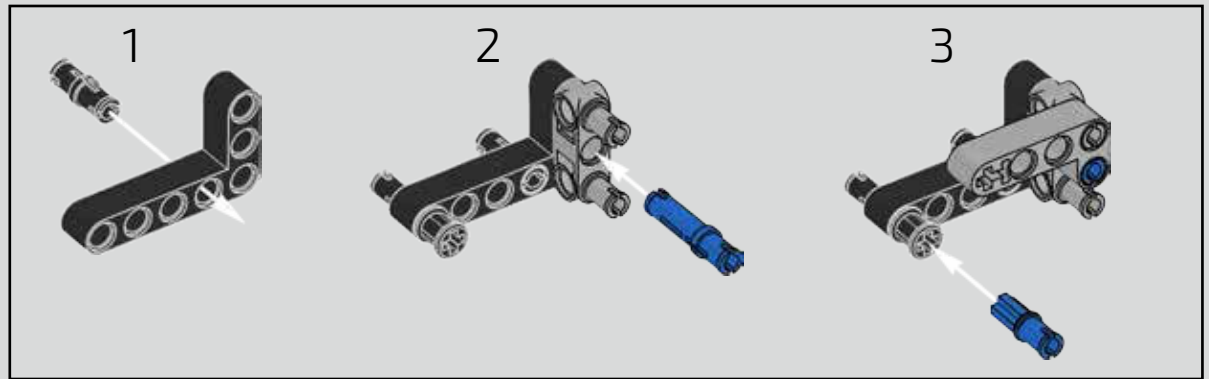

48

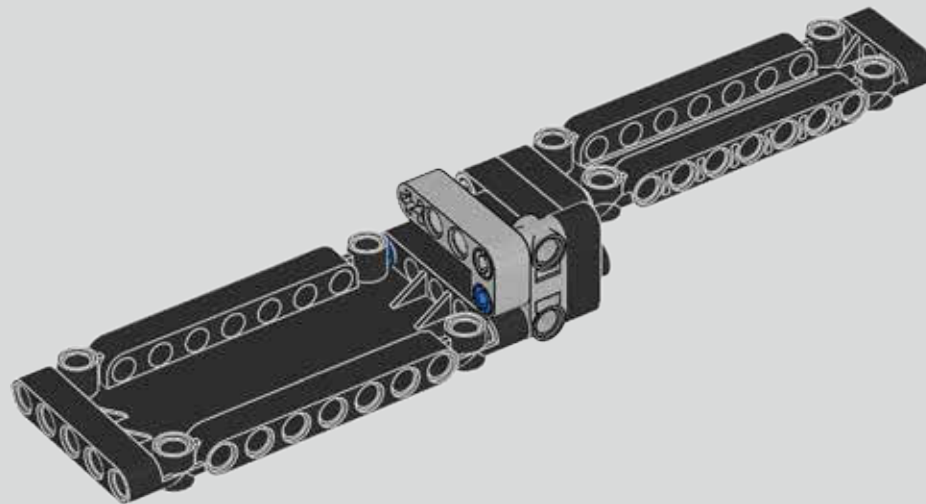

49

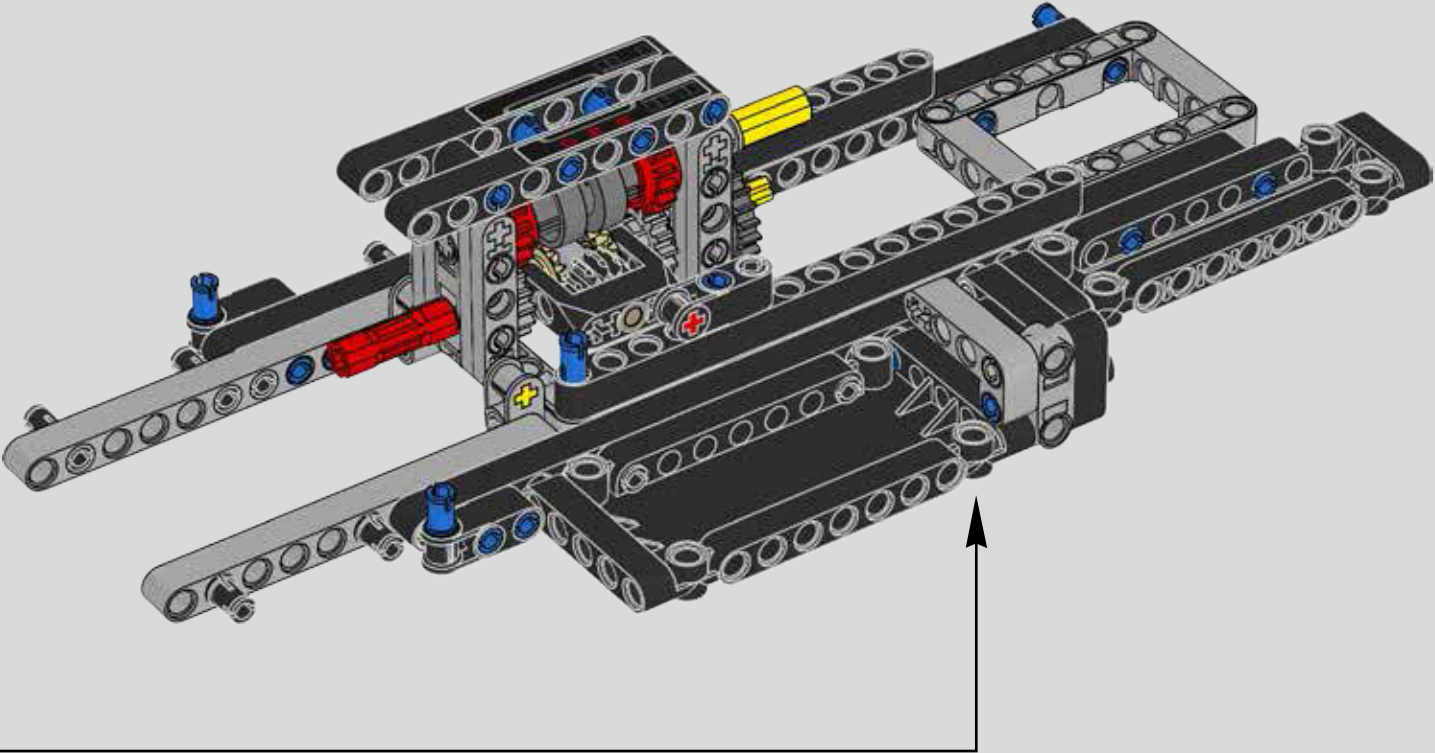

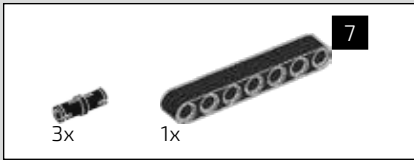

50

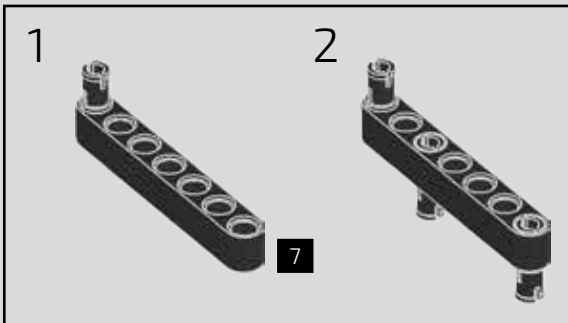
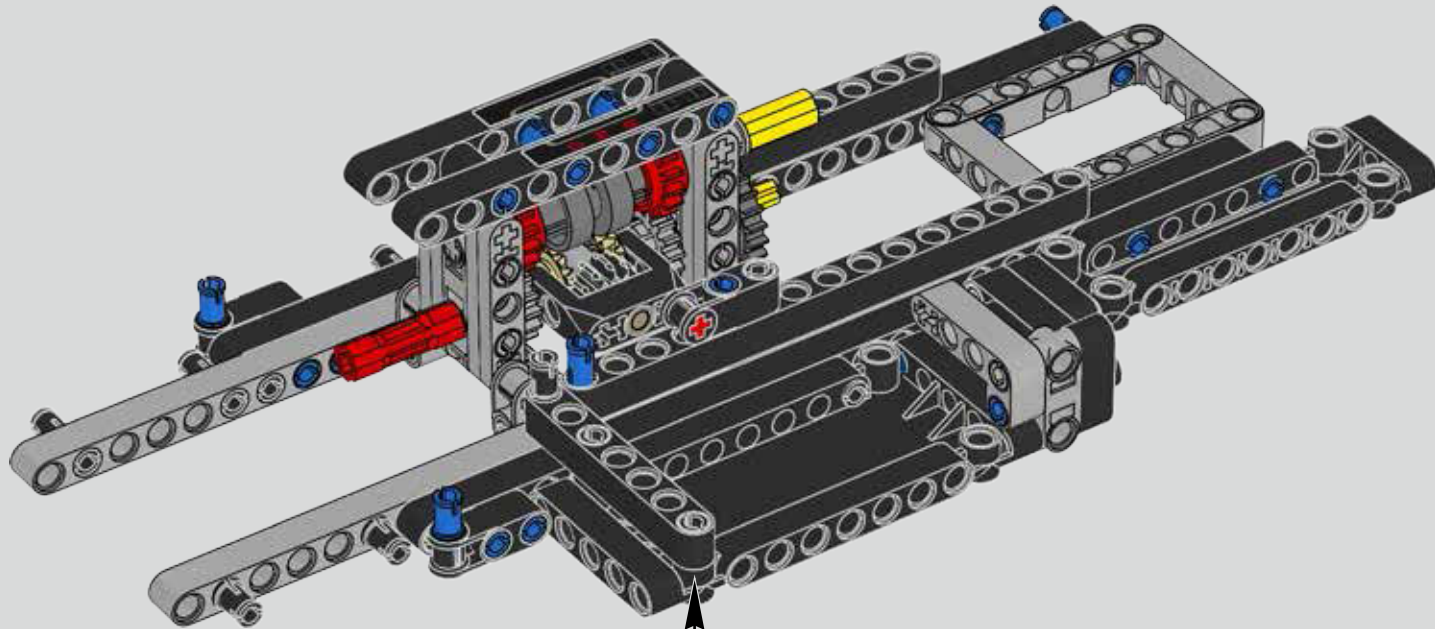

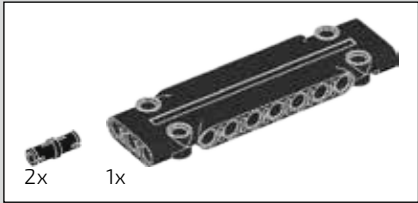
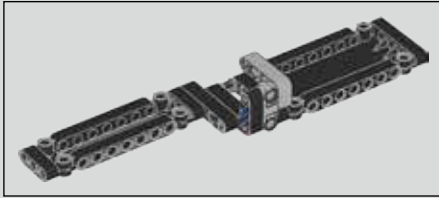

51

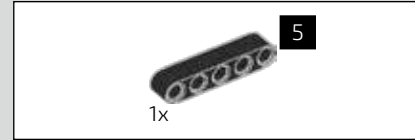
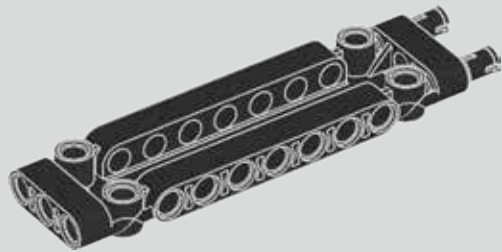

52

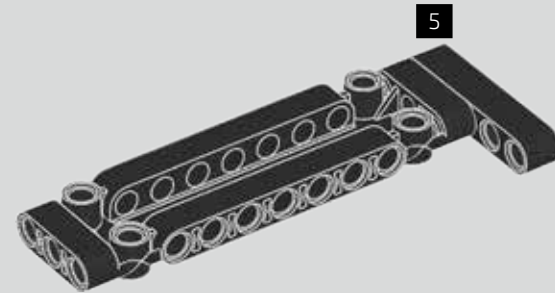

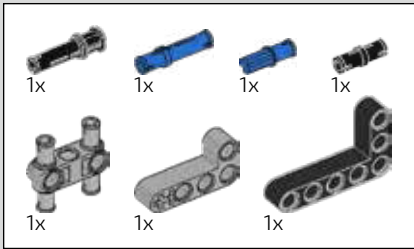

53

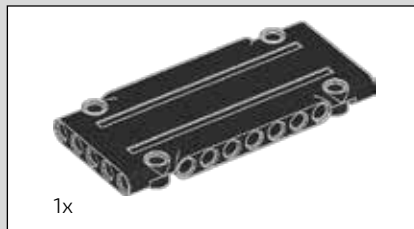
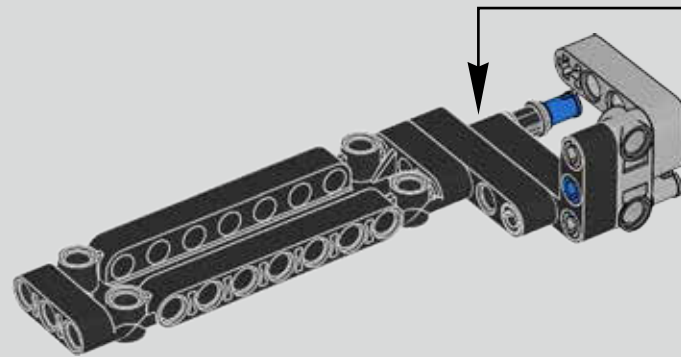
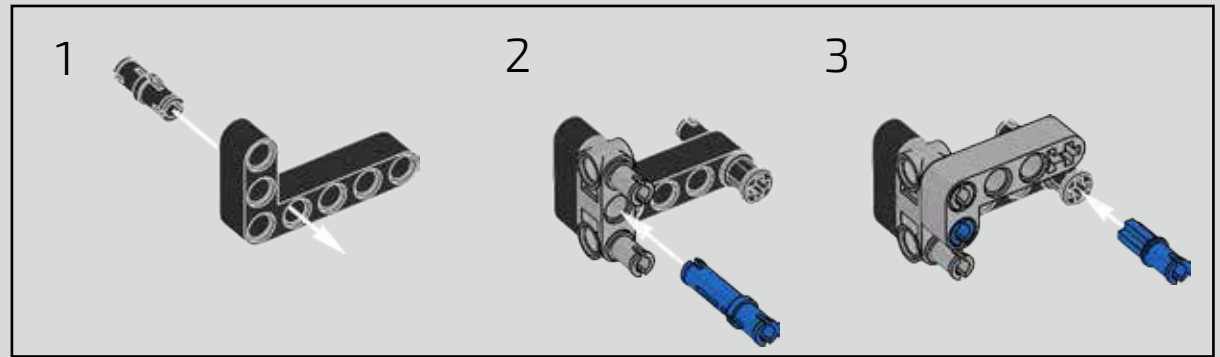

54

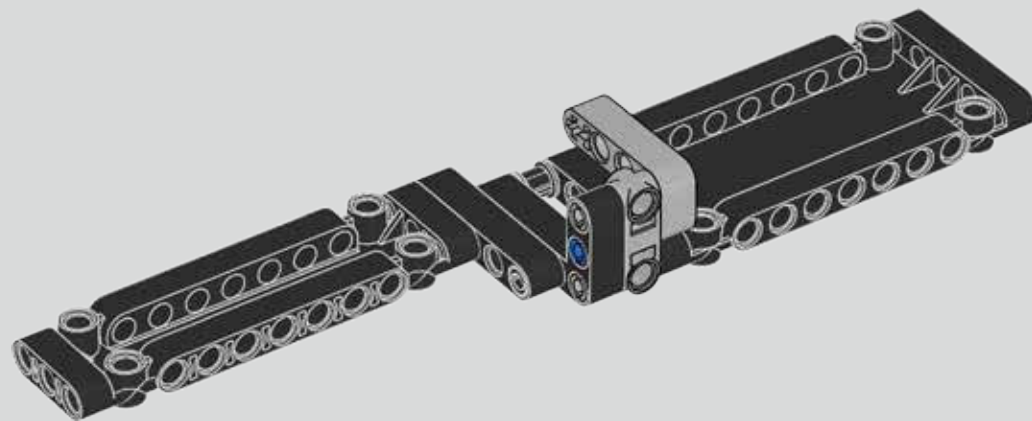

55

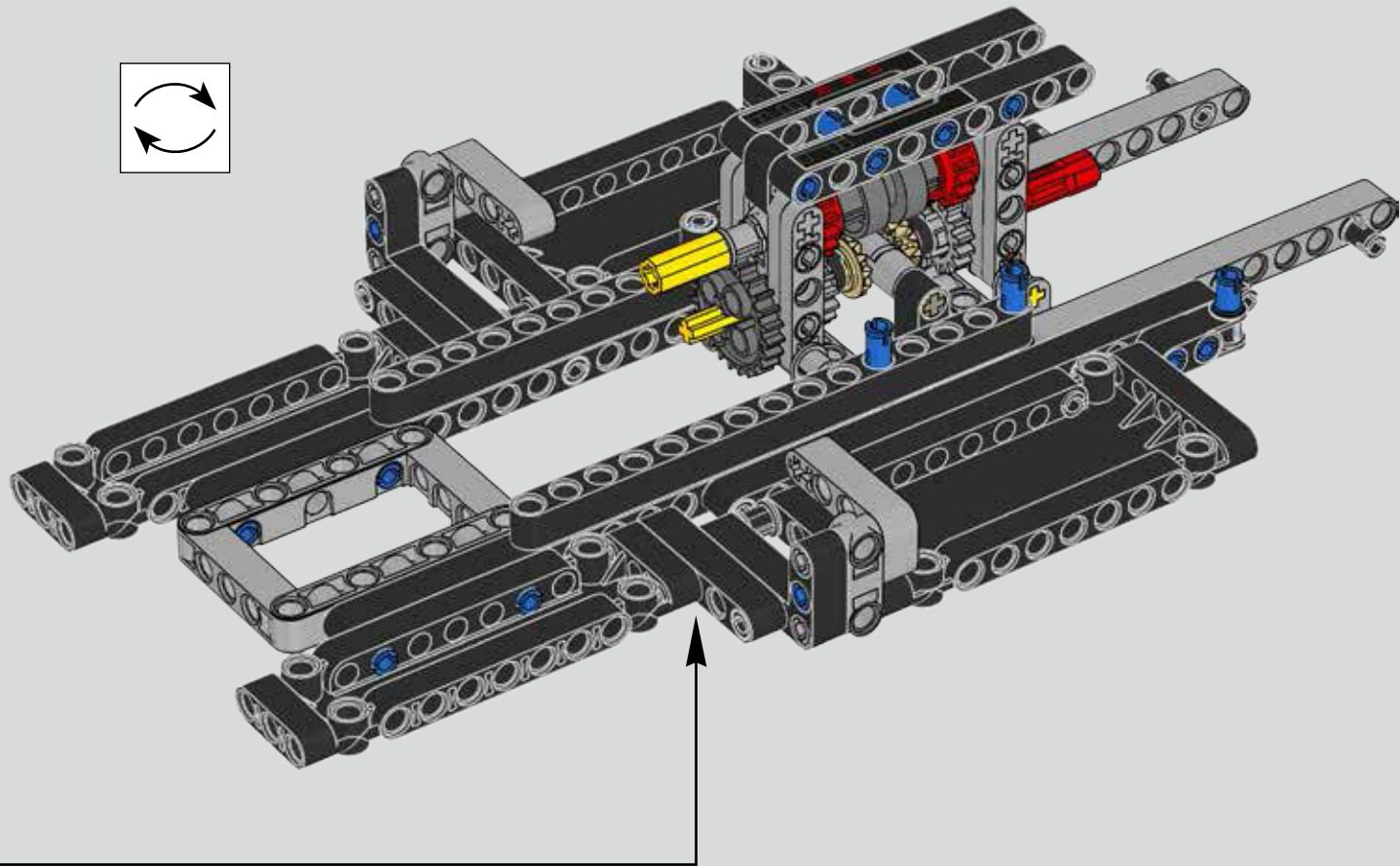
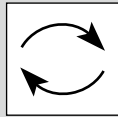

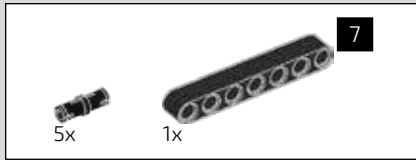

56

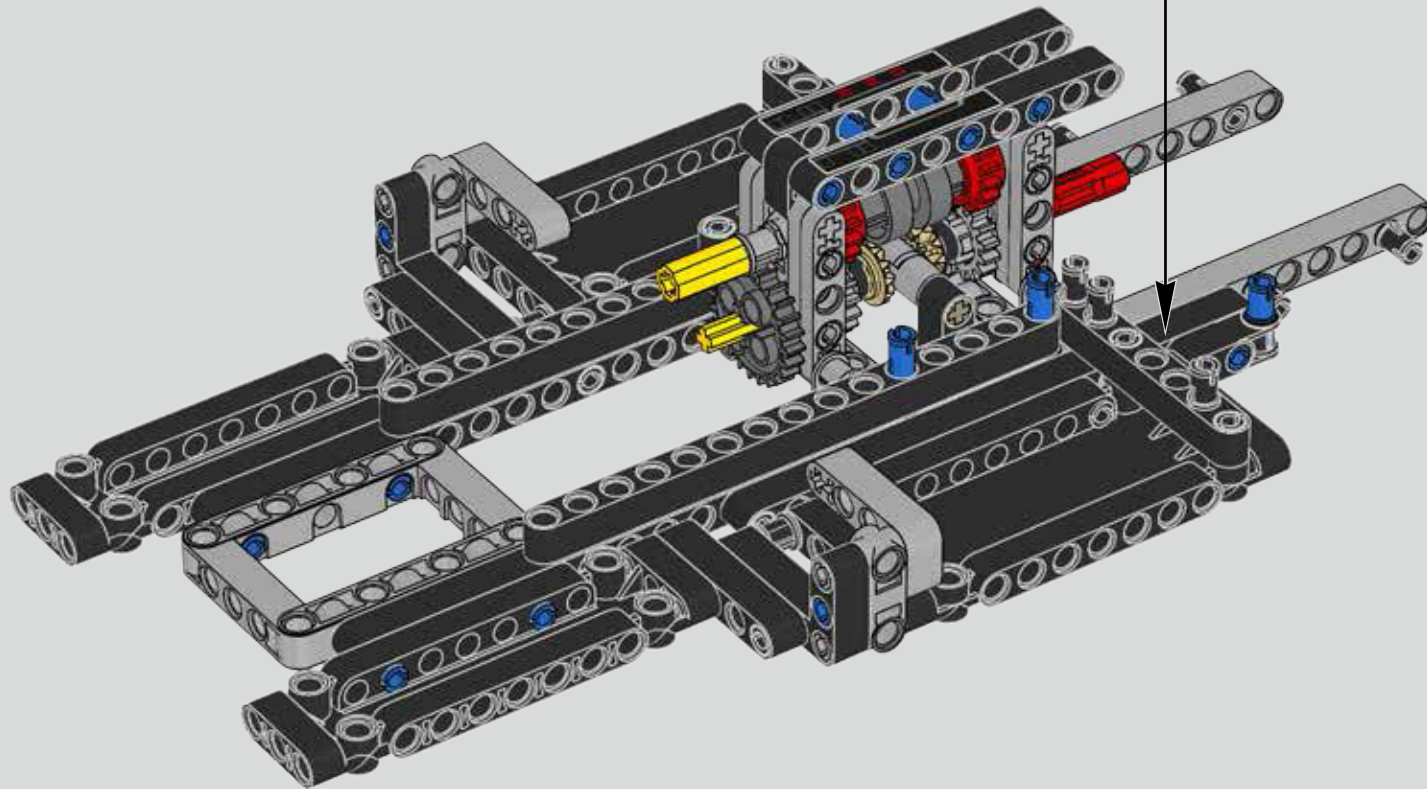
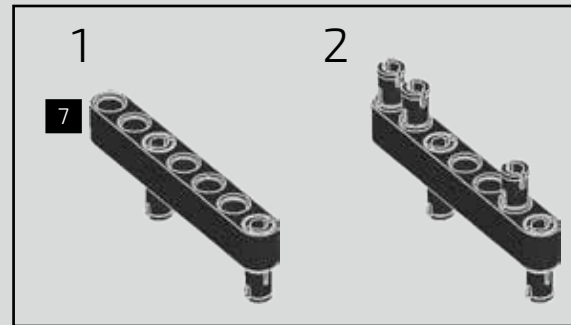

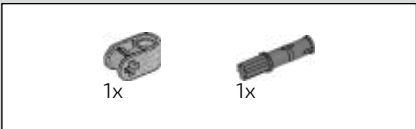

57

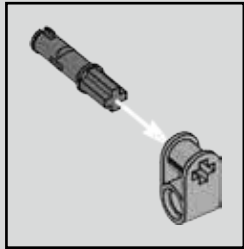
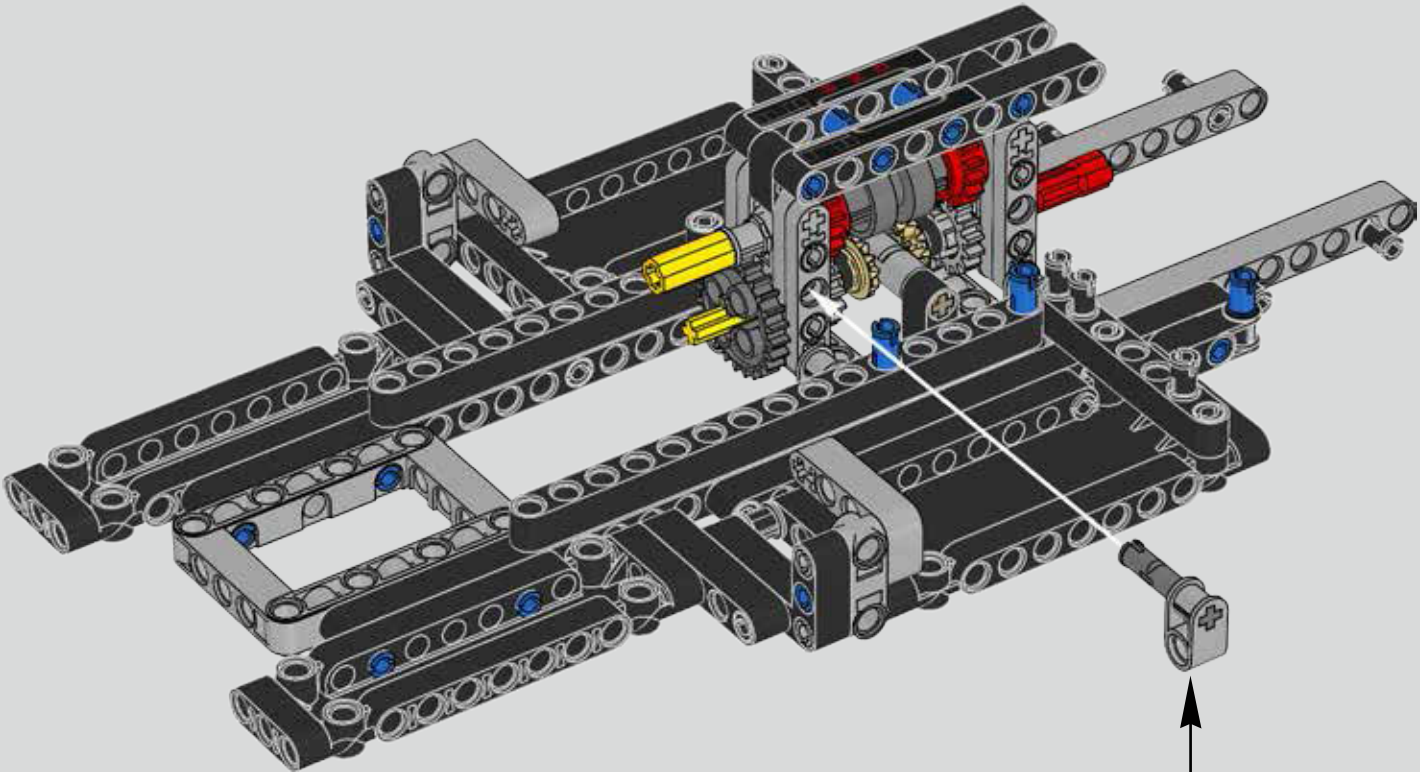

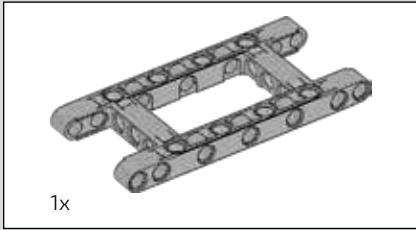
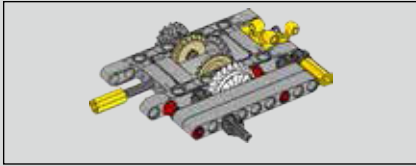

58

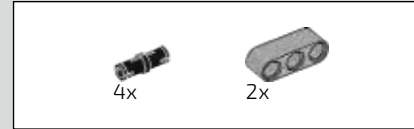
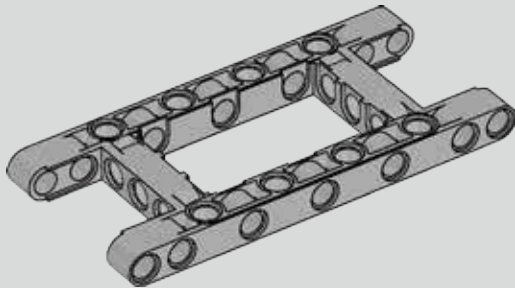

59

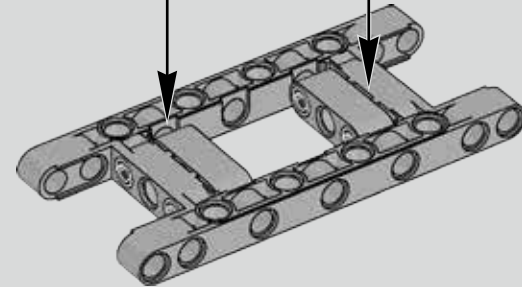
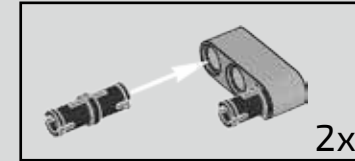

60

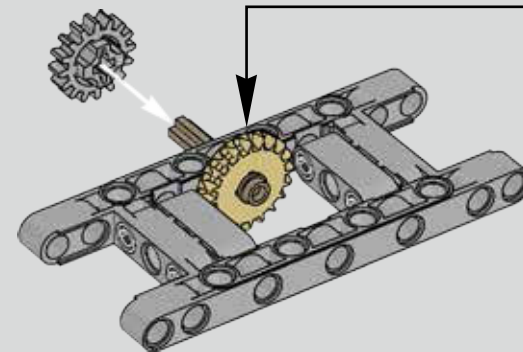
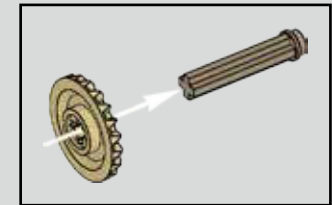

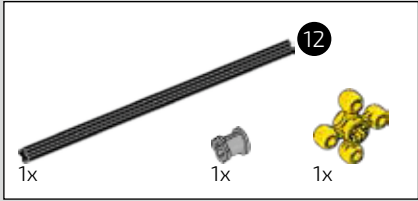

61

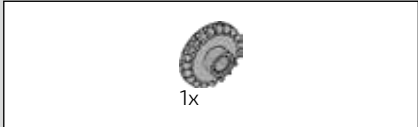
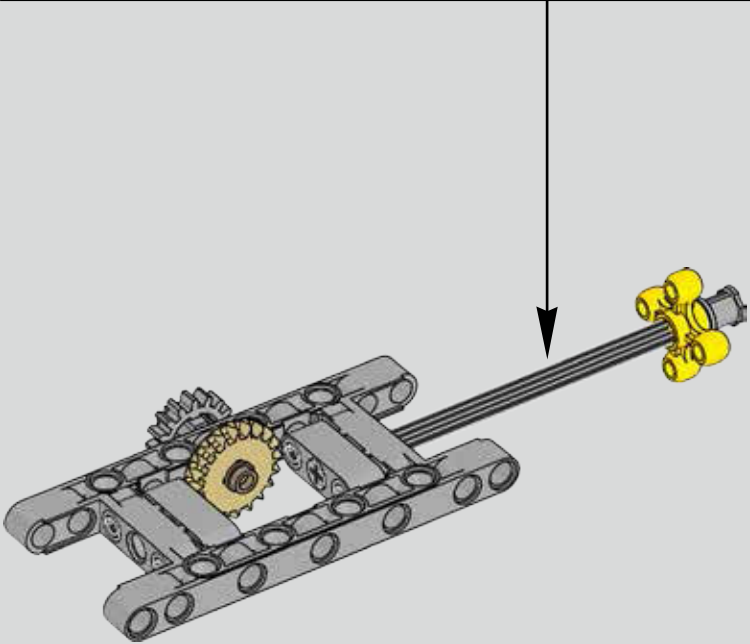
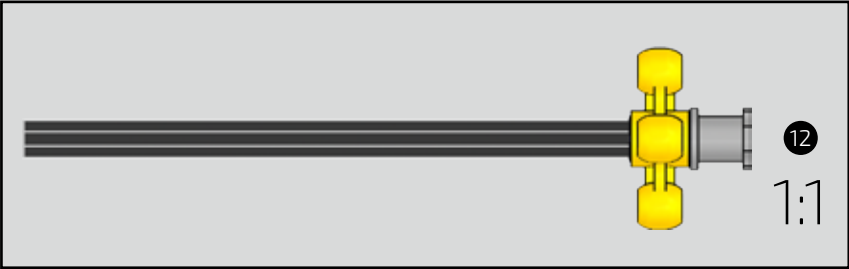

62

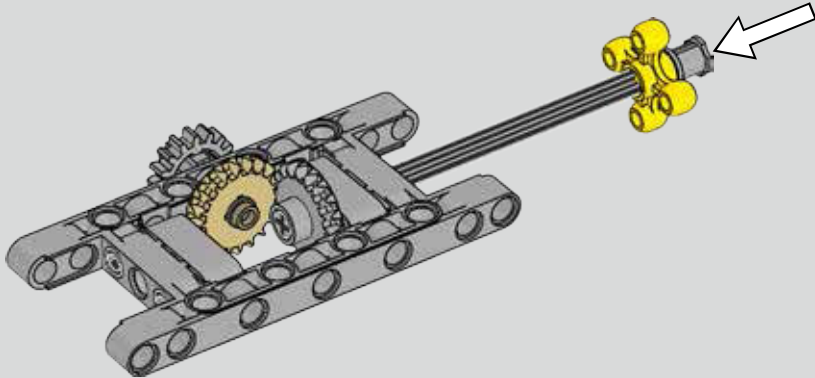

63

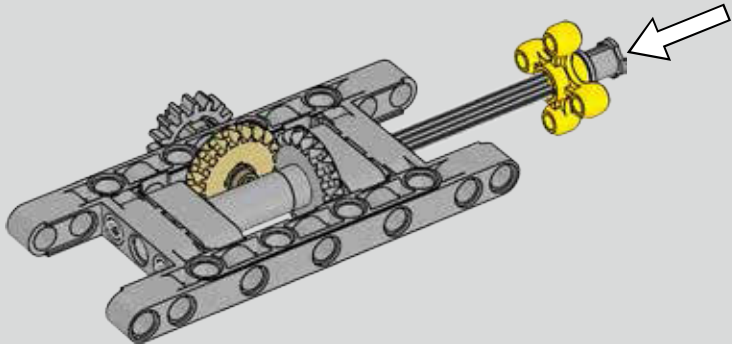

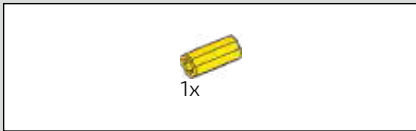

64

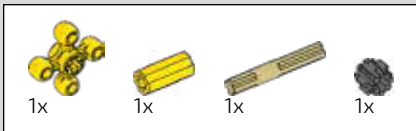
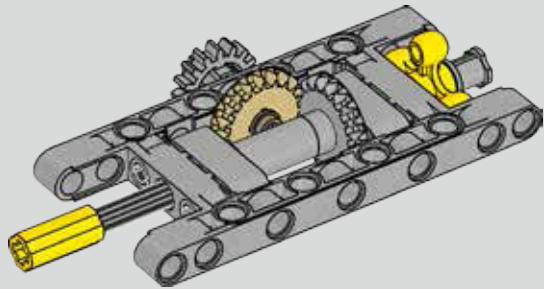

65

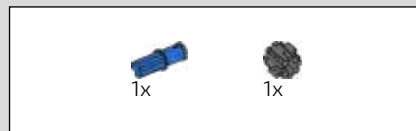
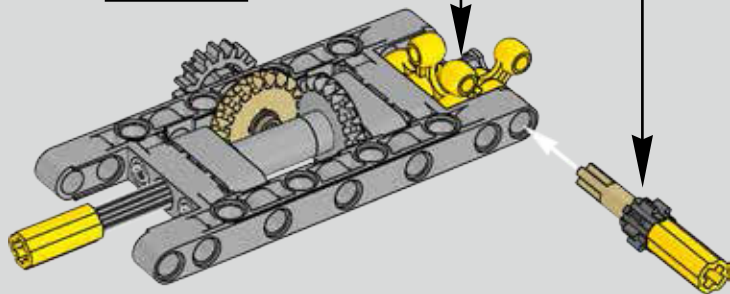
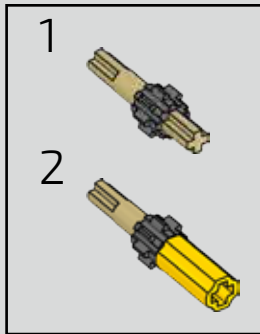
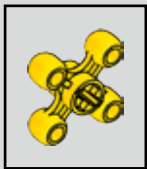

66

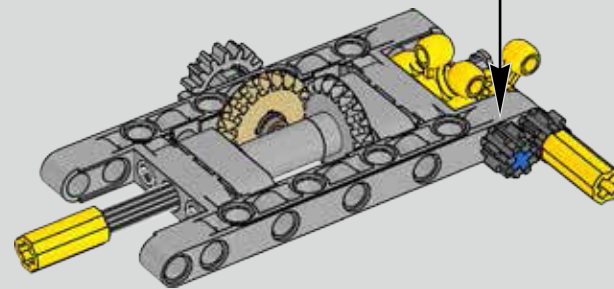
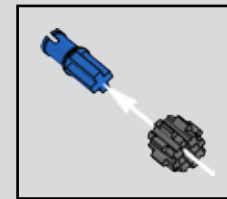



67

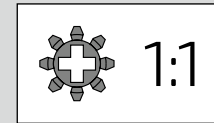
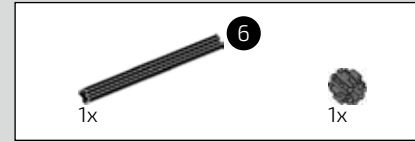
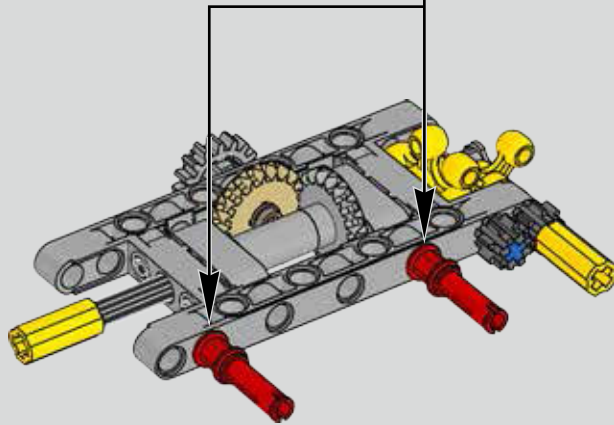
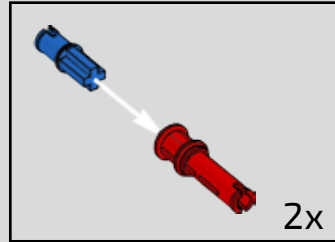

68

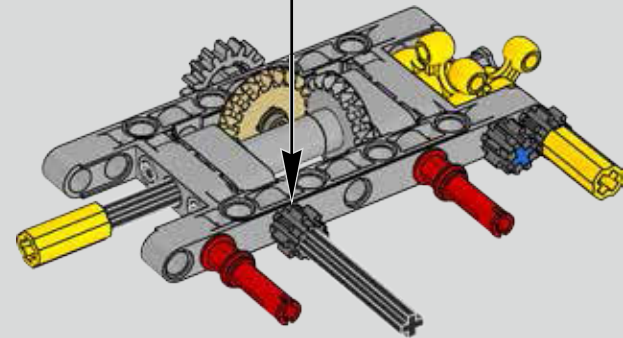

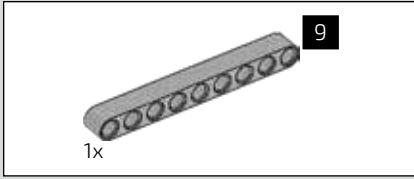

69

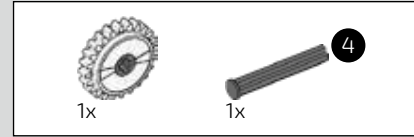
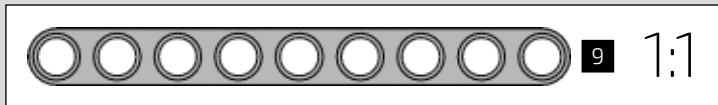
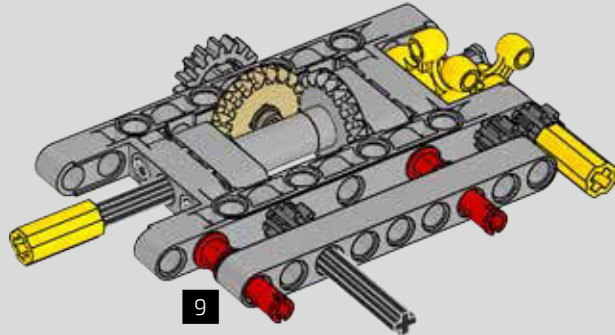

70

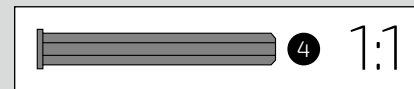
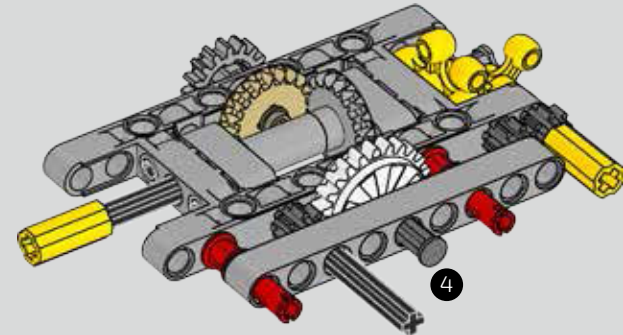

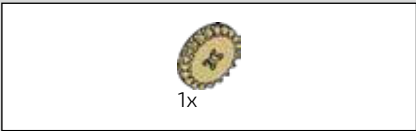

71

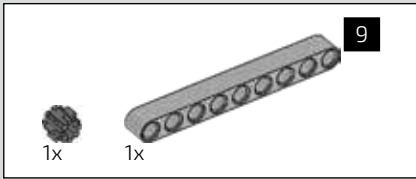
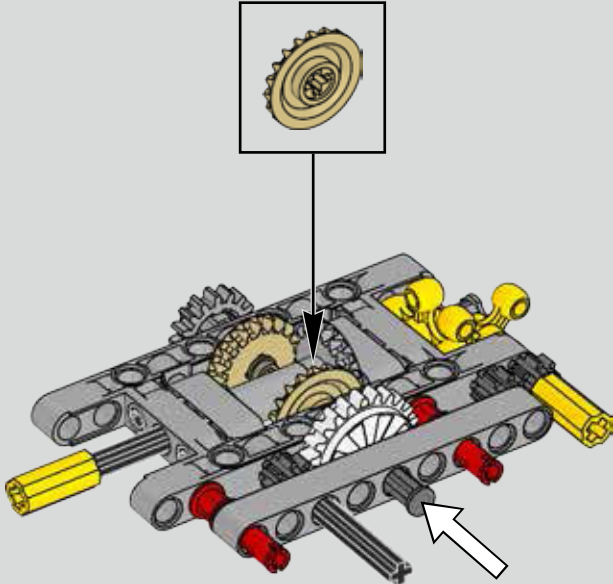

72

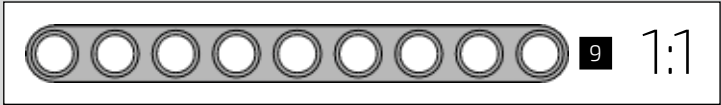
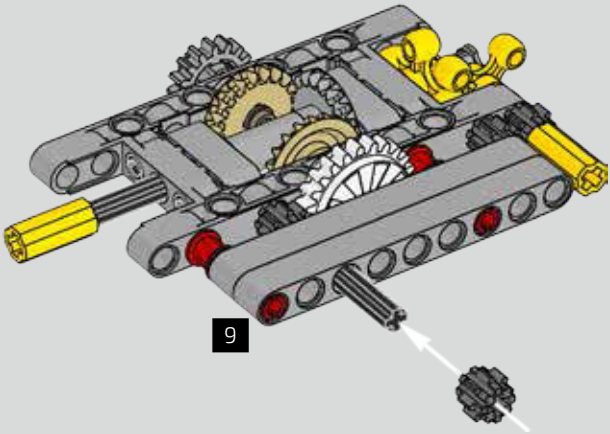
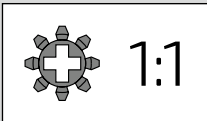

73

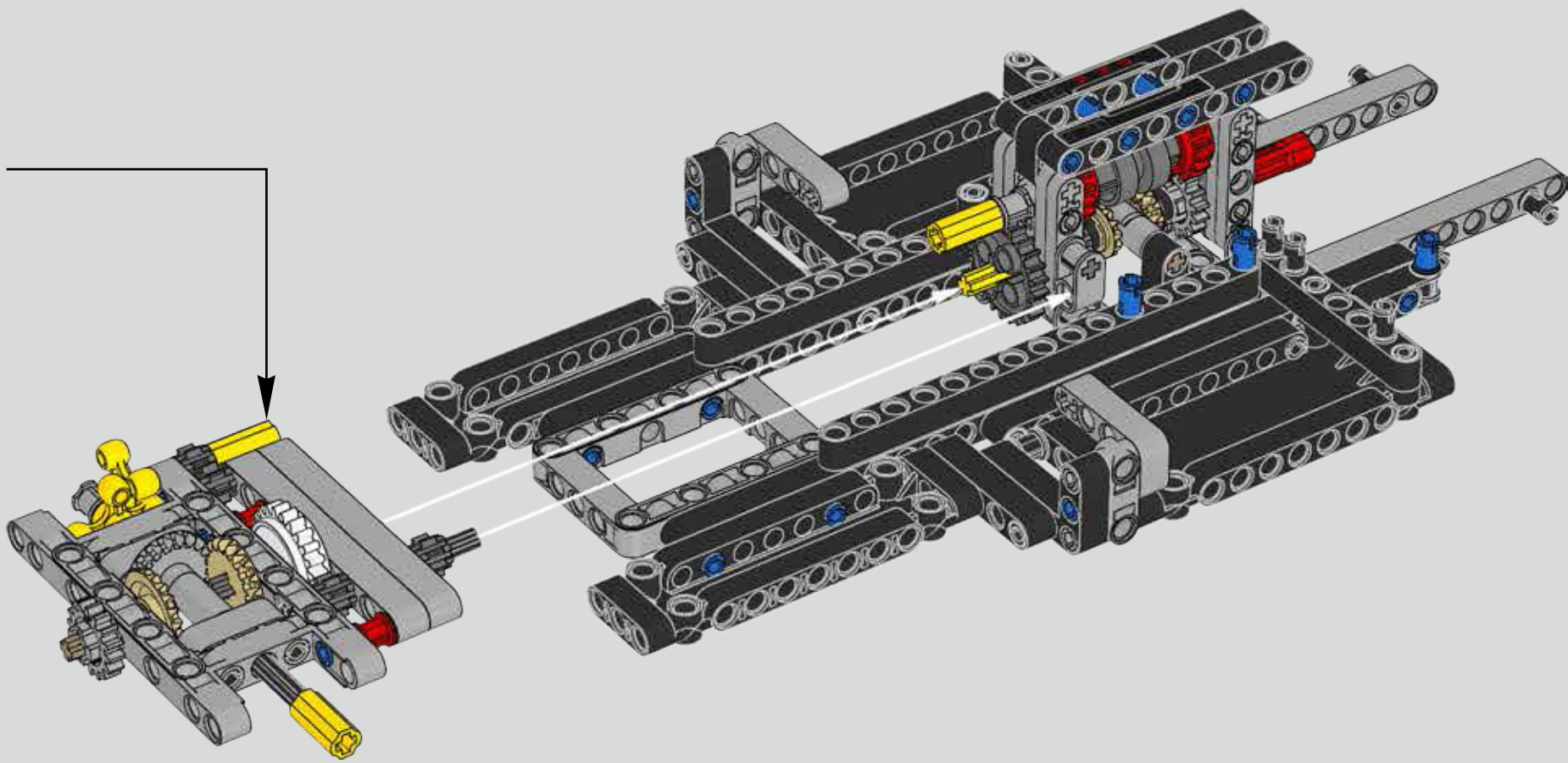



74

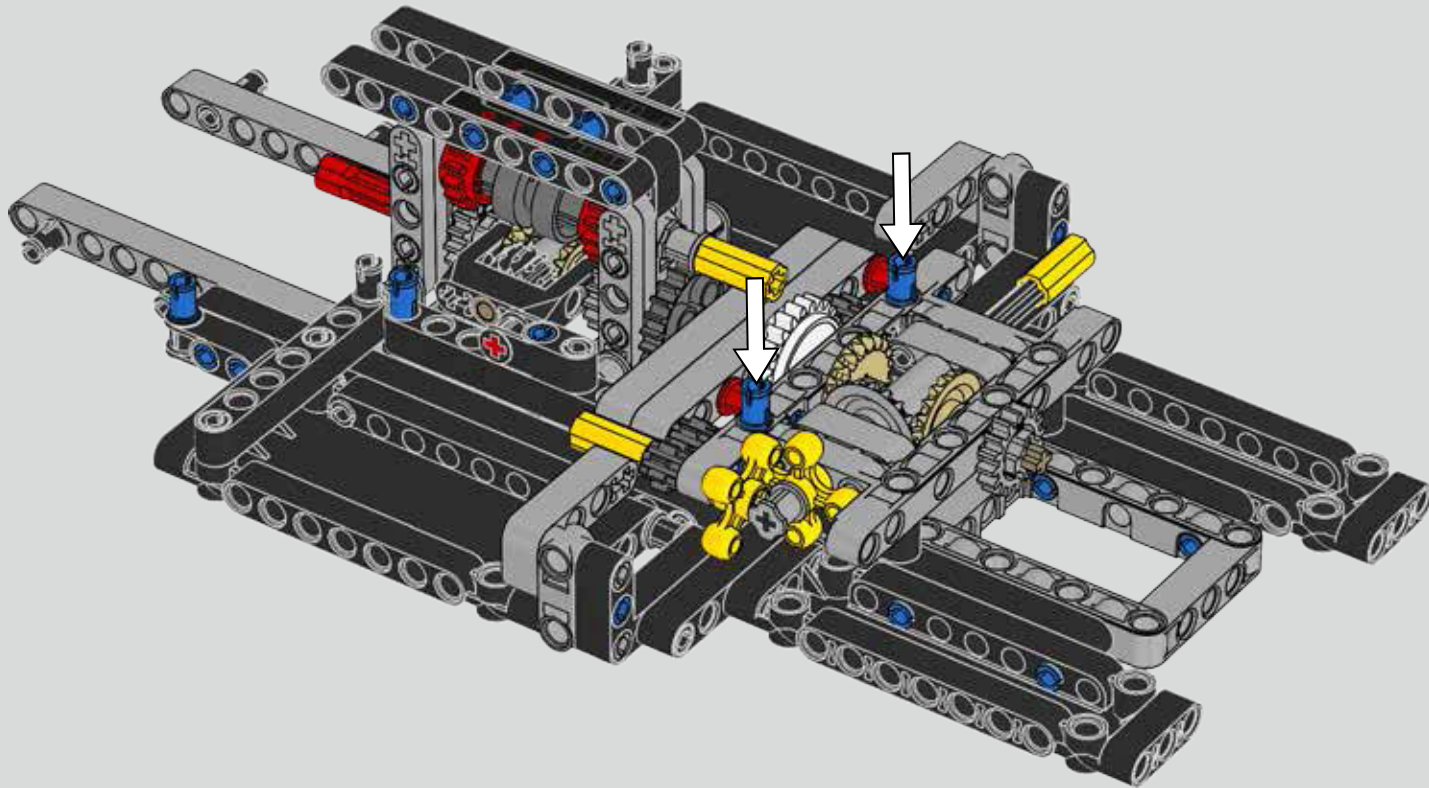
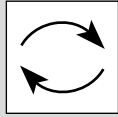

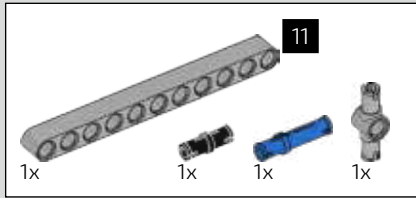

75

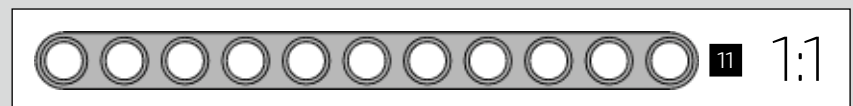
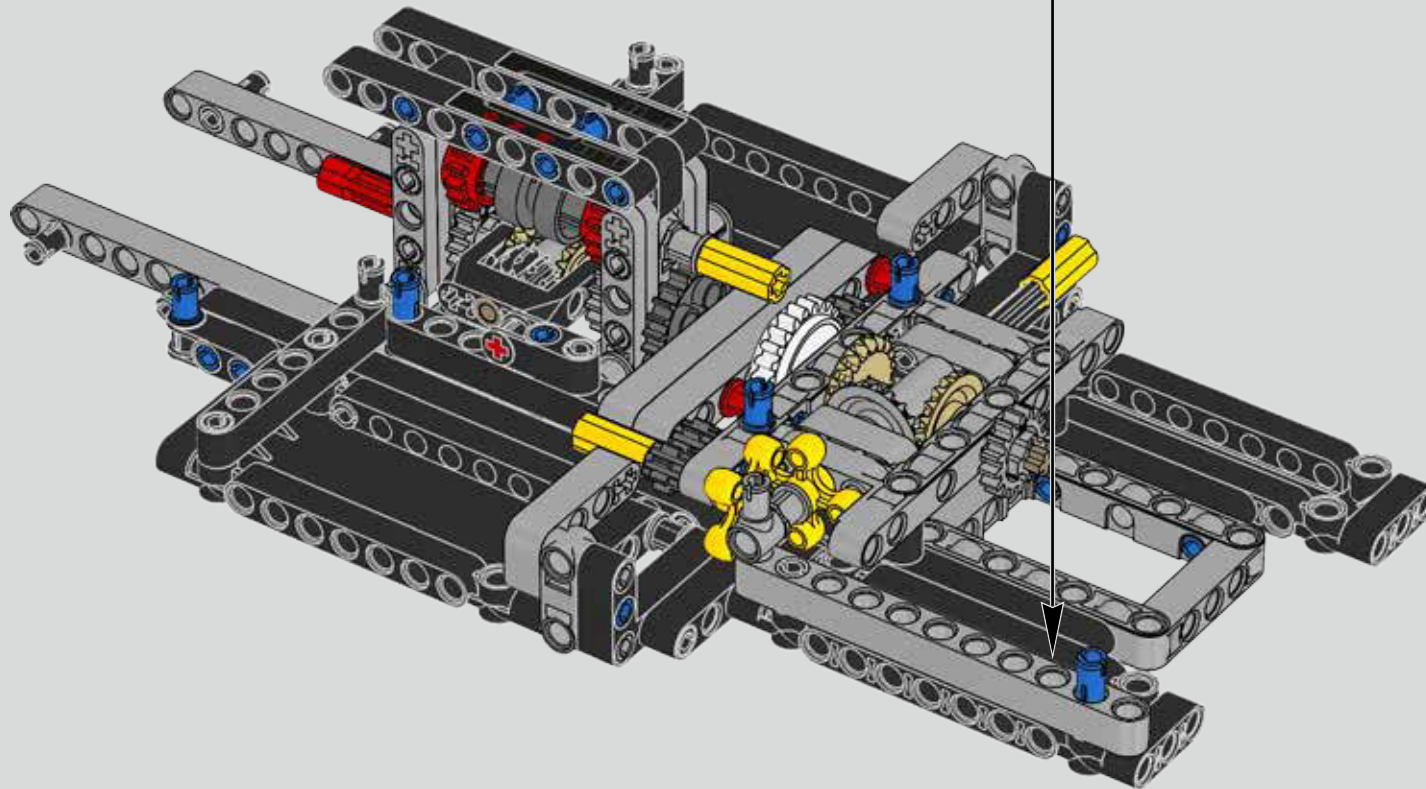
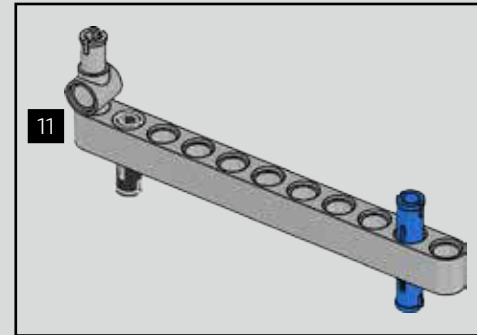

76

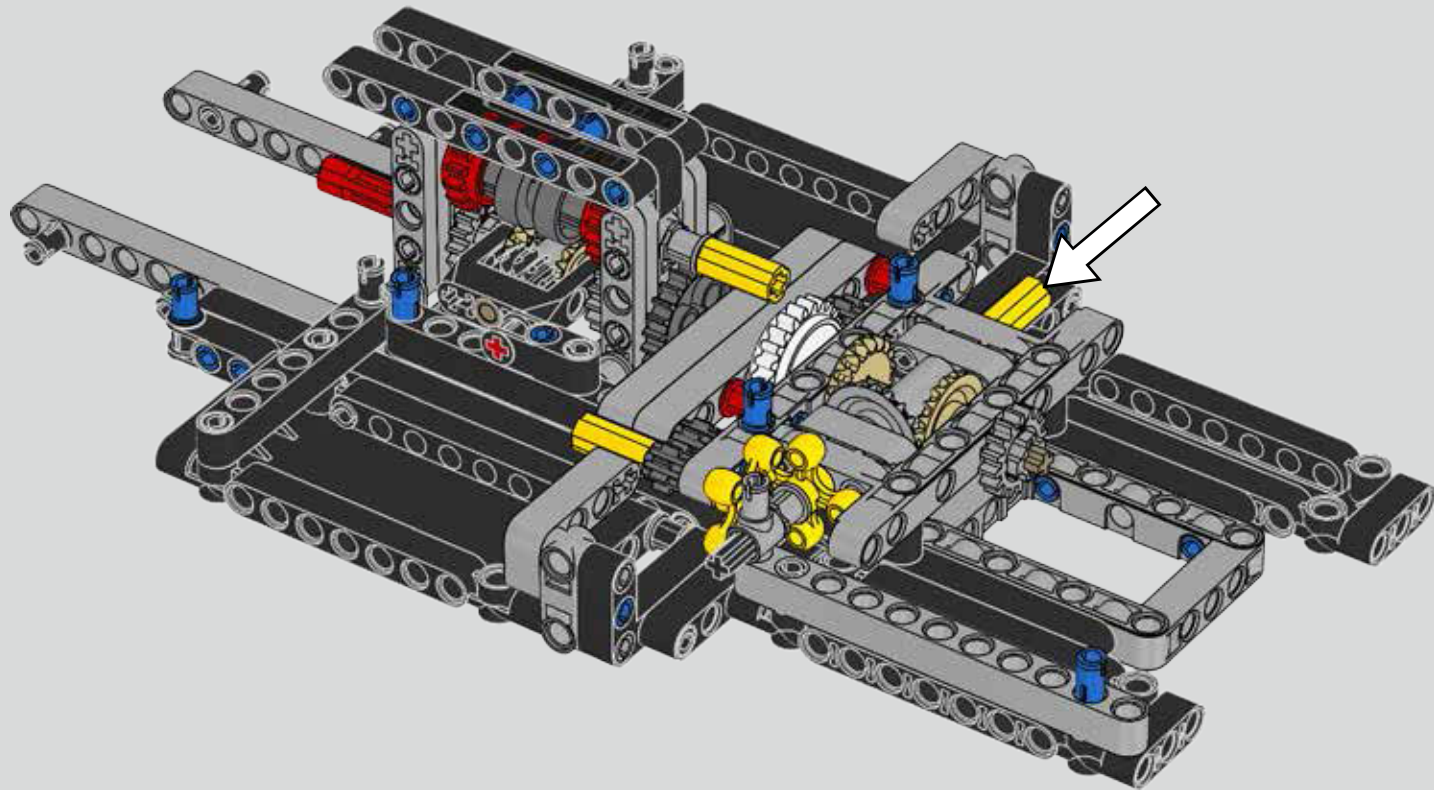

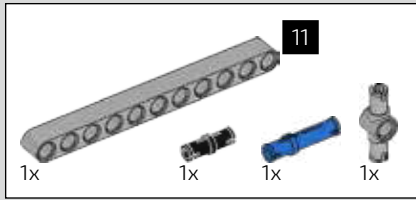

77

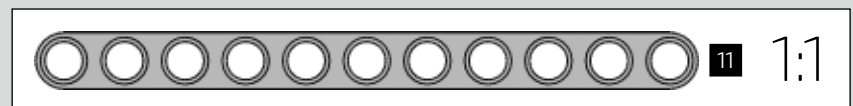
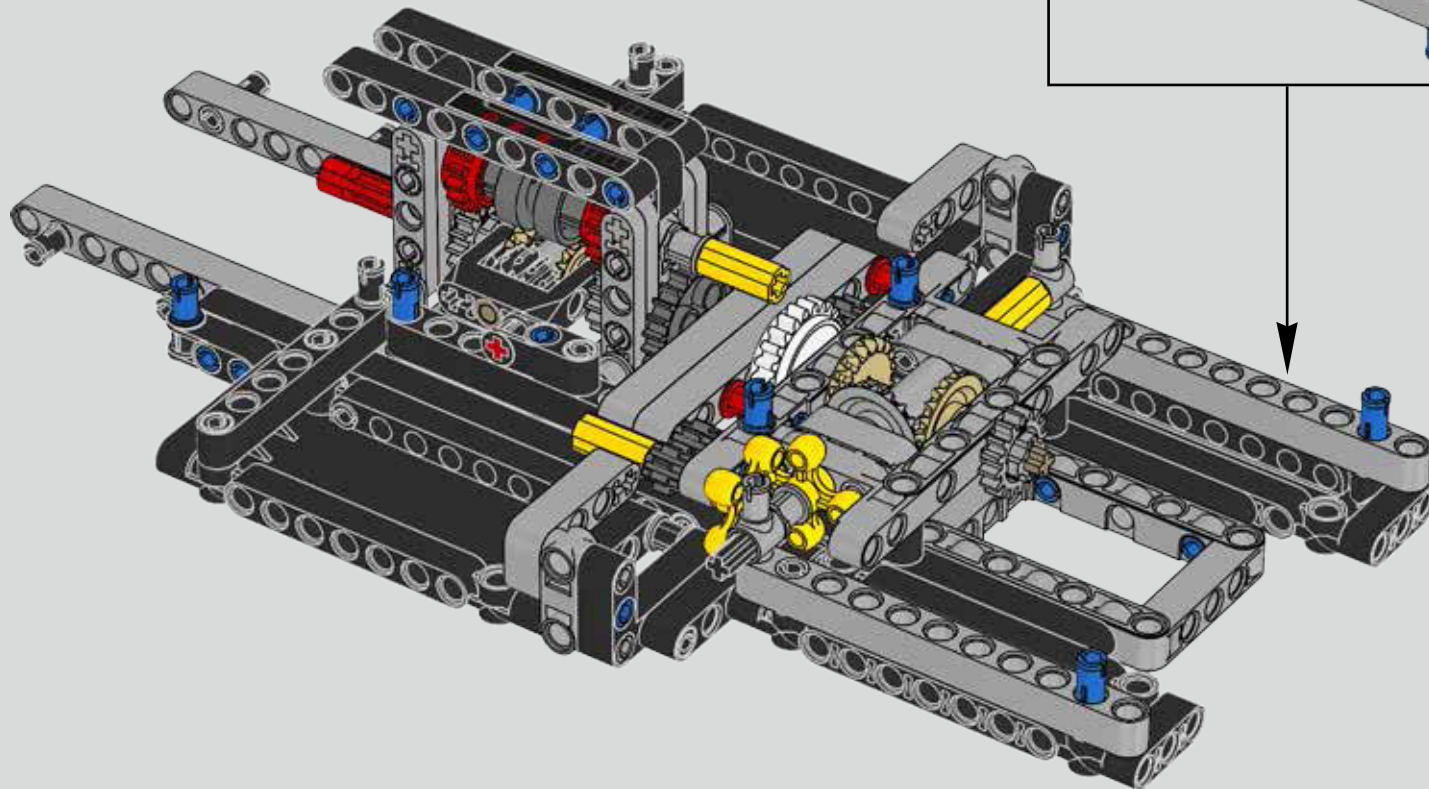
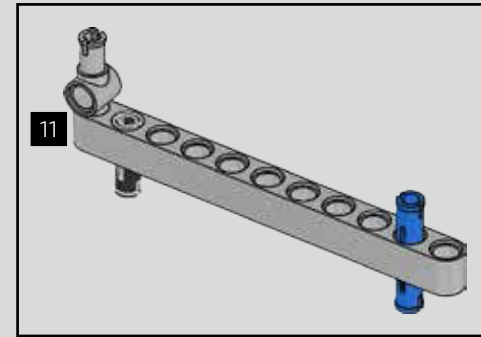



78

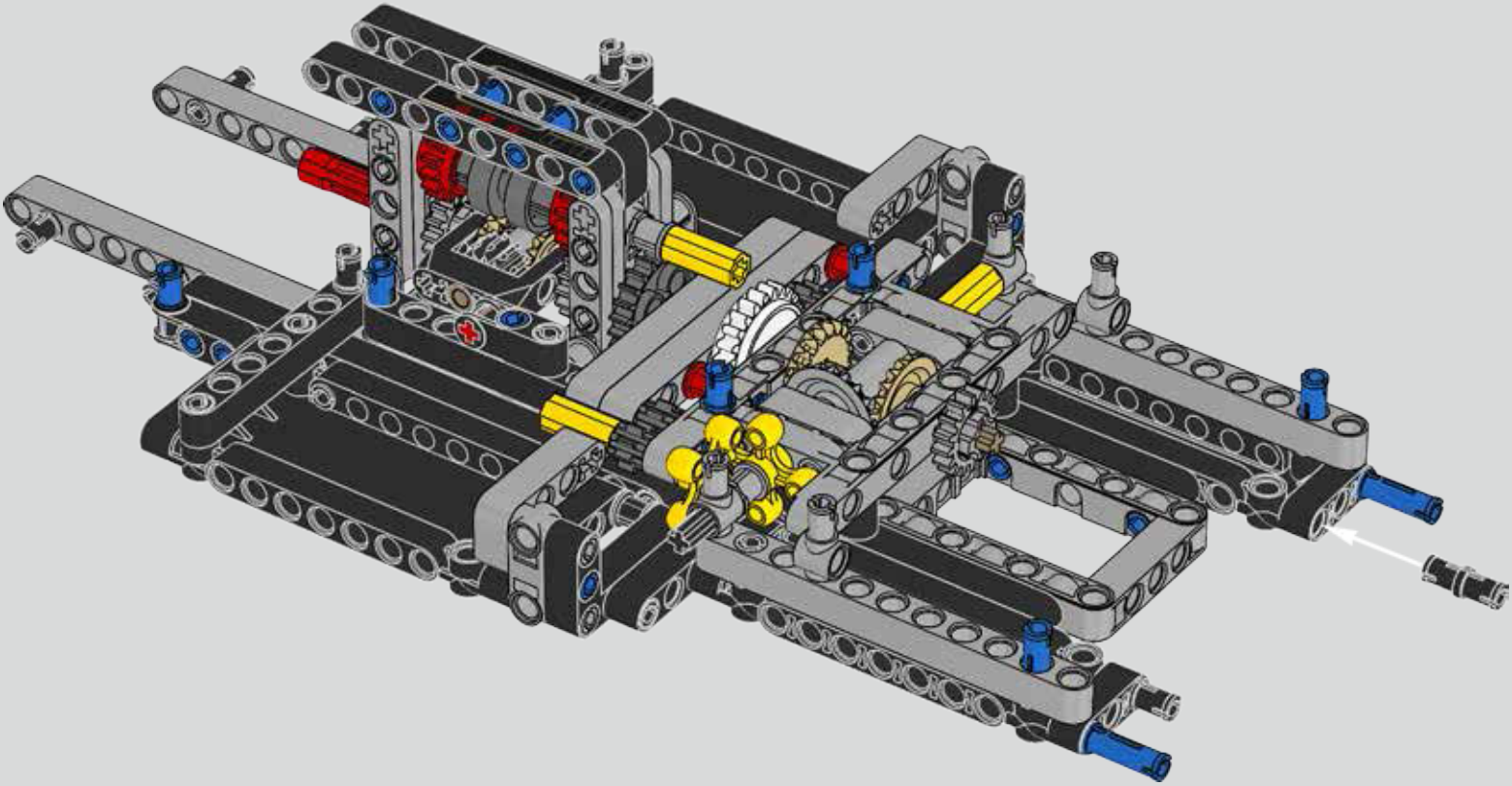

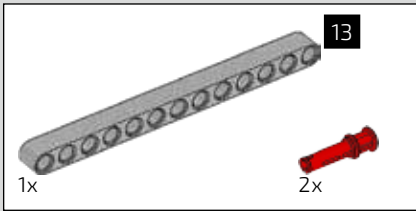
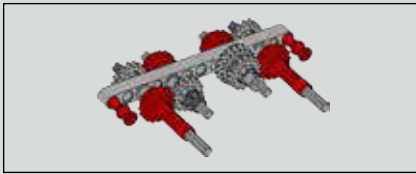

79

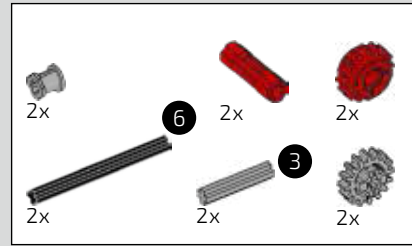
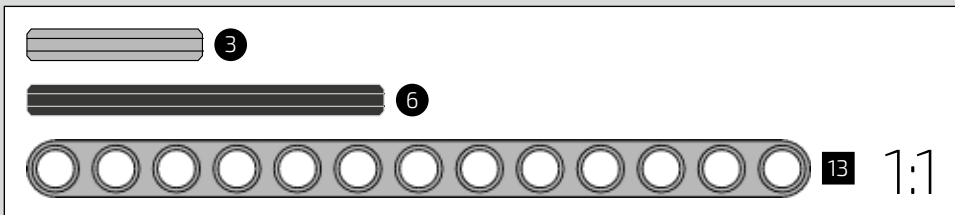
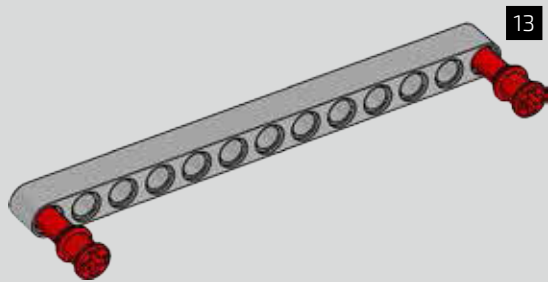

80

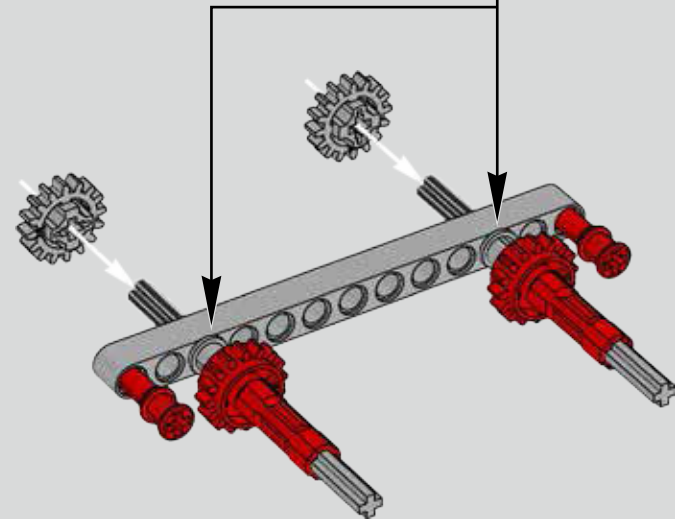
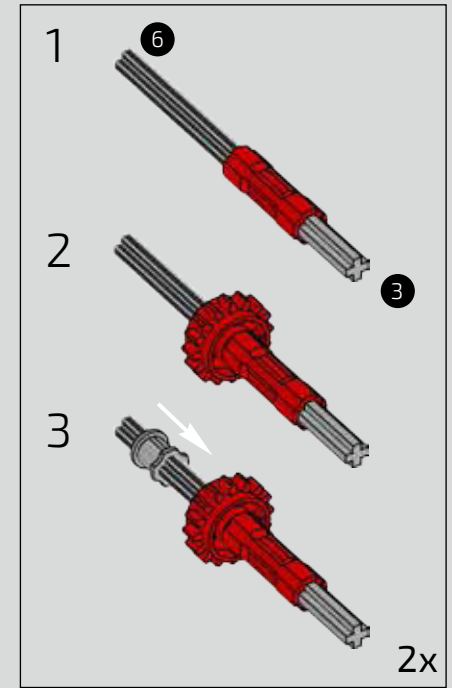

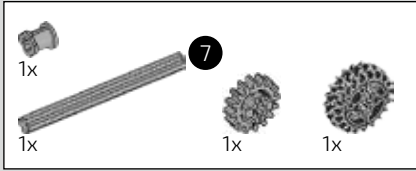

81

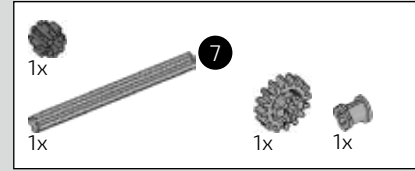
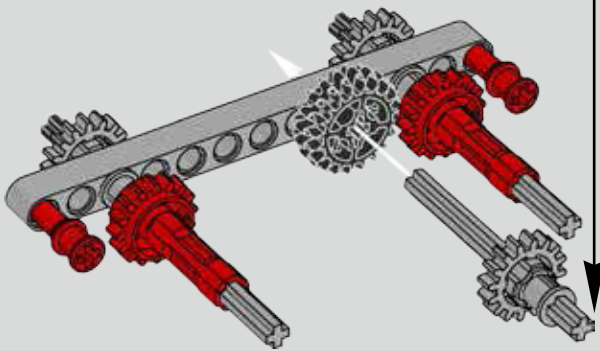
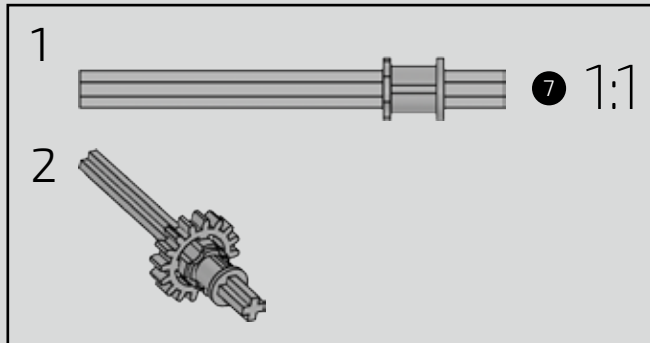

82

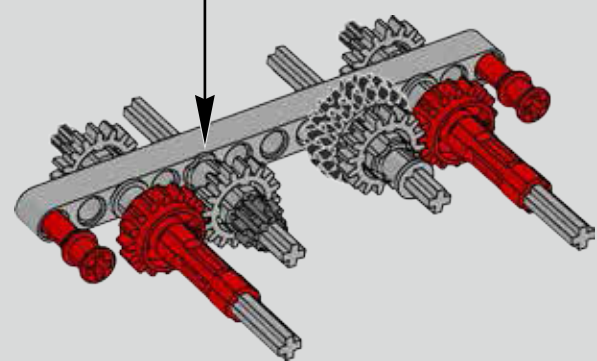
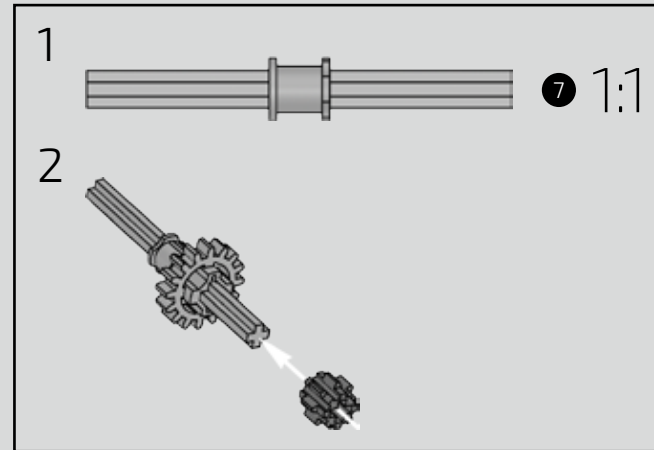
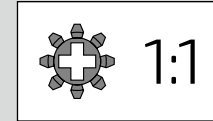



83

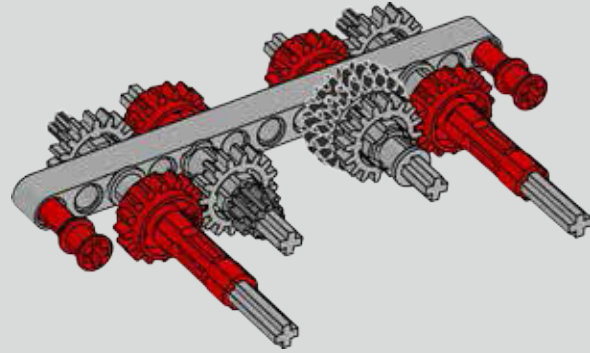

84

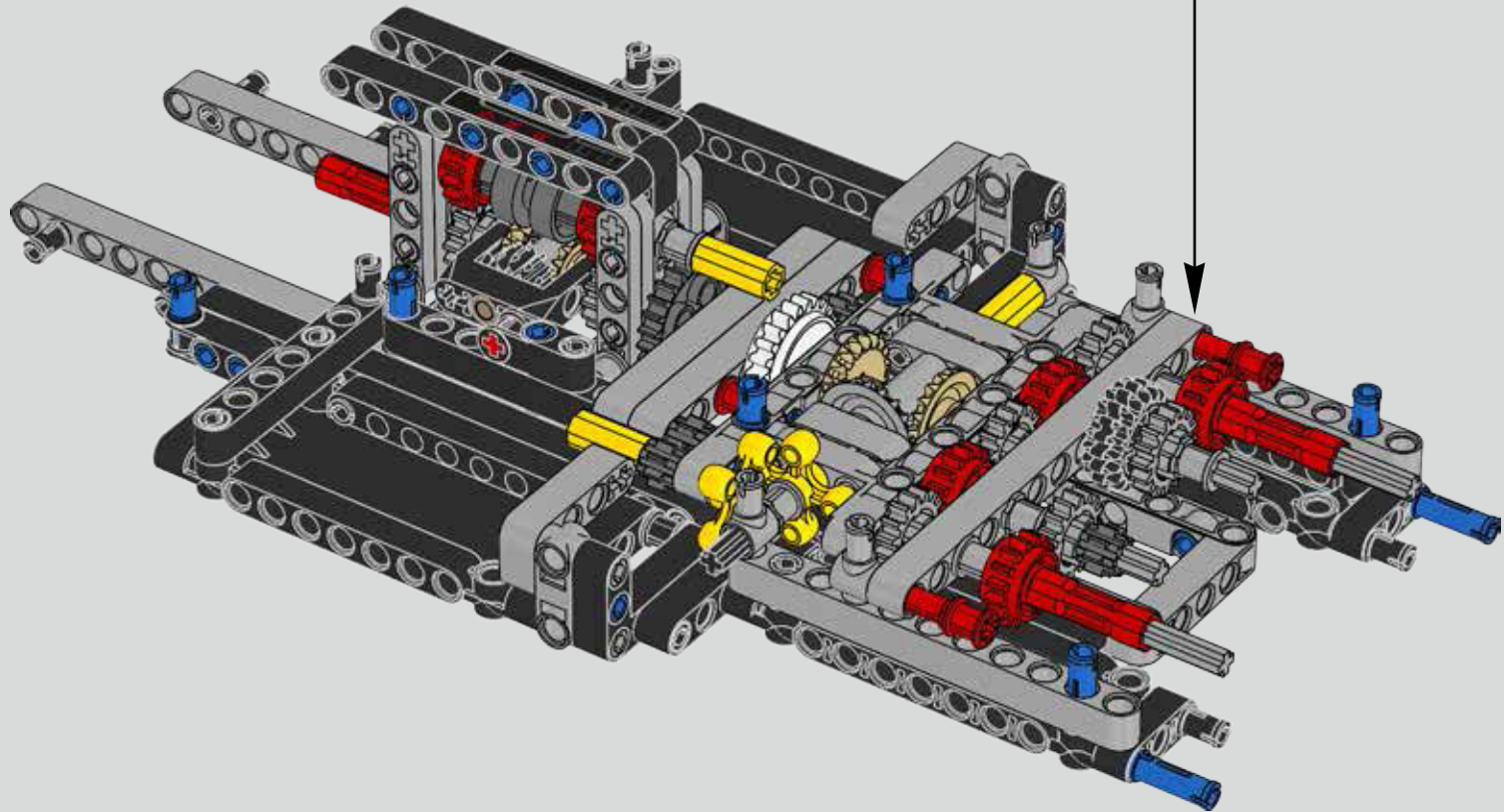

85

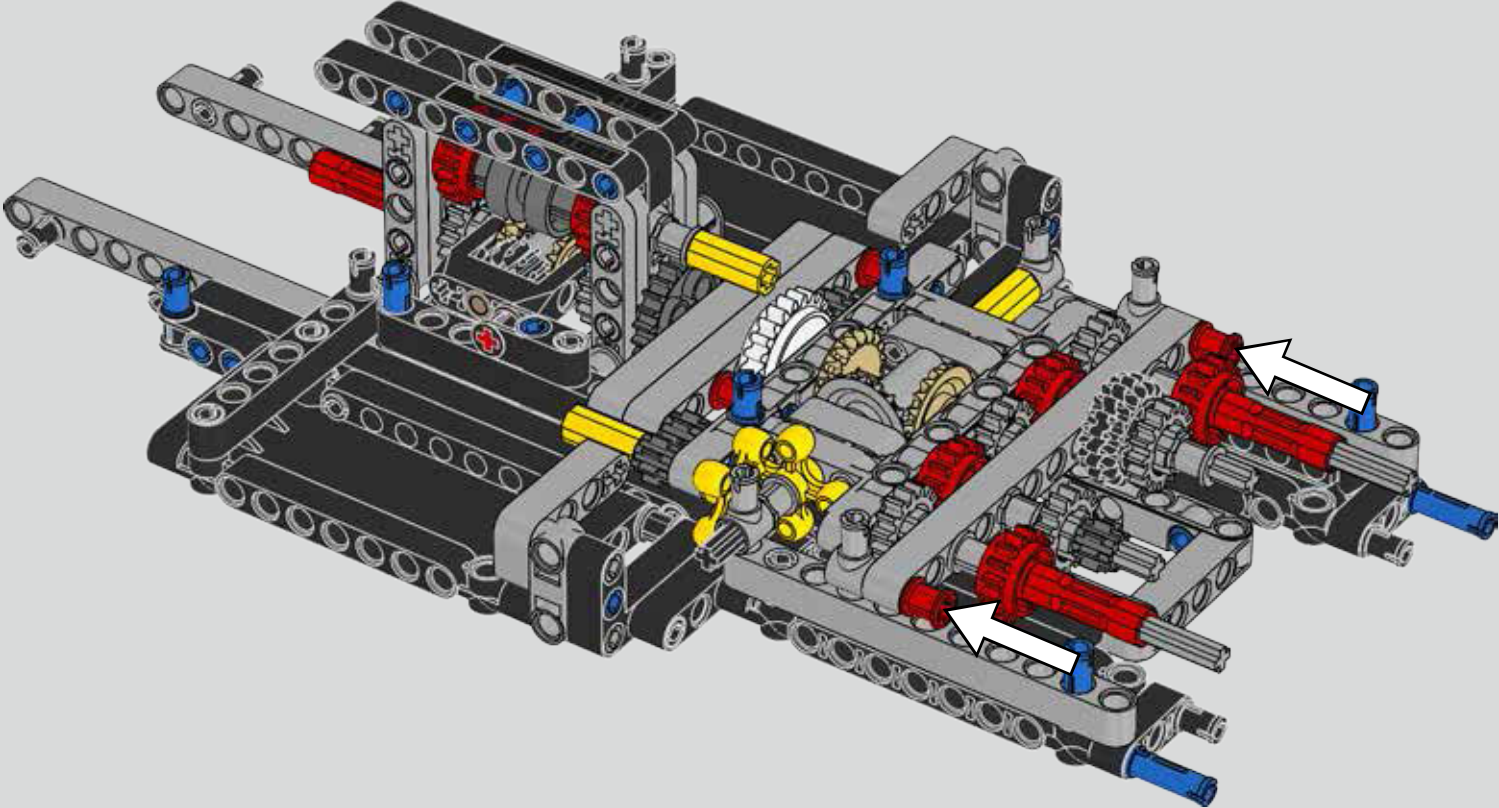

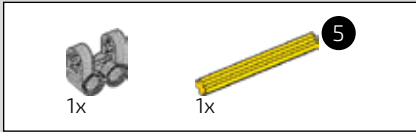
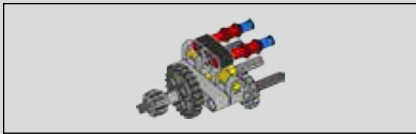

86

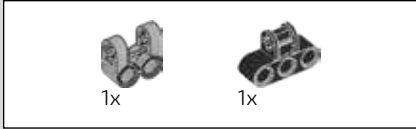
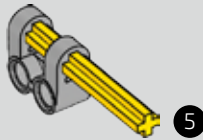

87

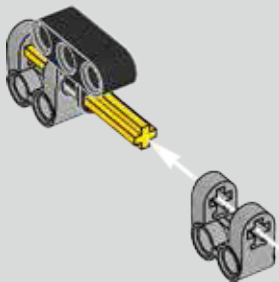

88

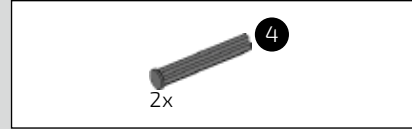
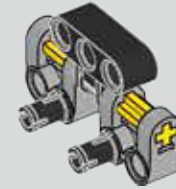

89

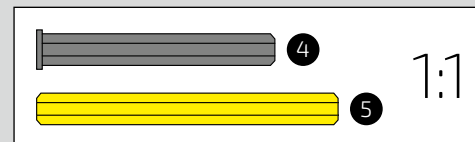
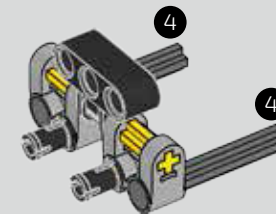

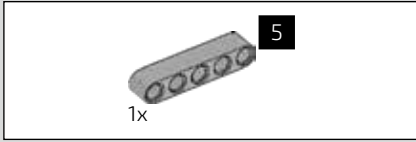

90

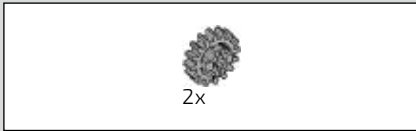
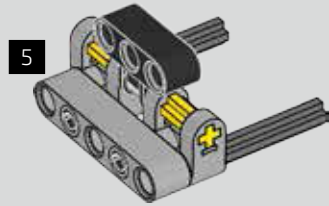

91

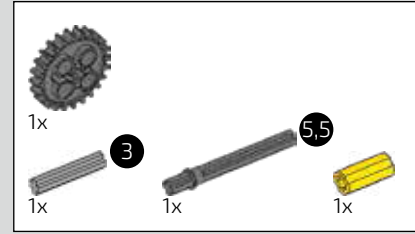
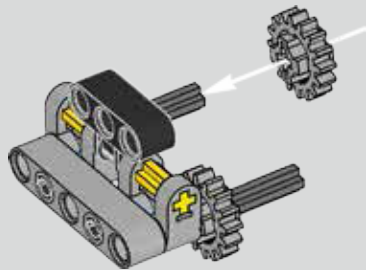

92

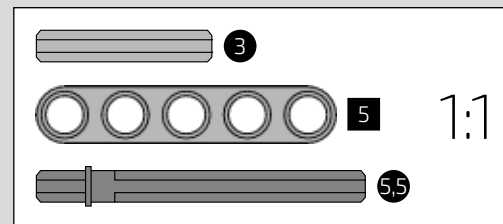
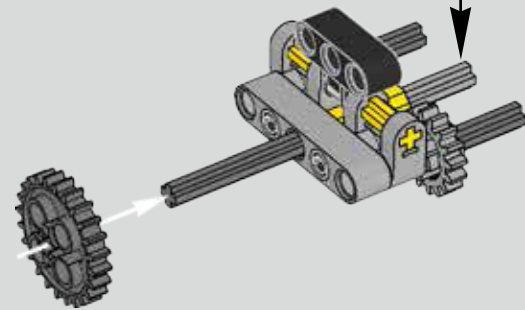
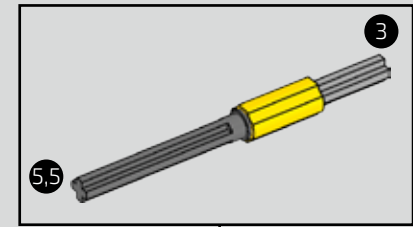

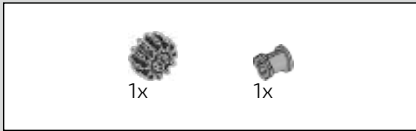

93

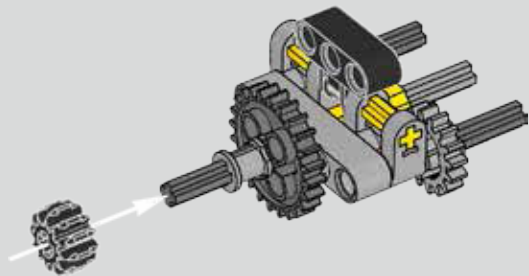

94

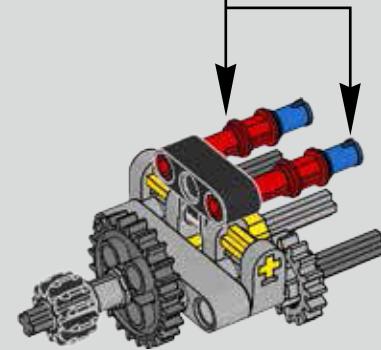
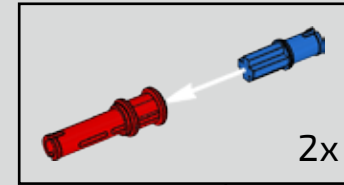

95

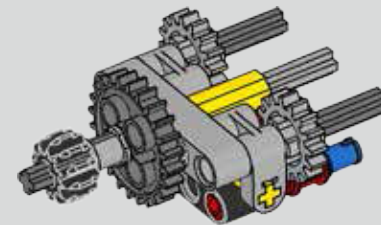
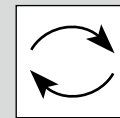

96

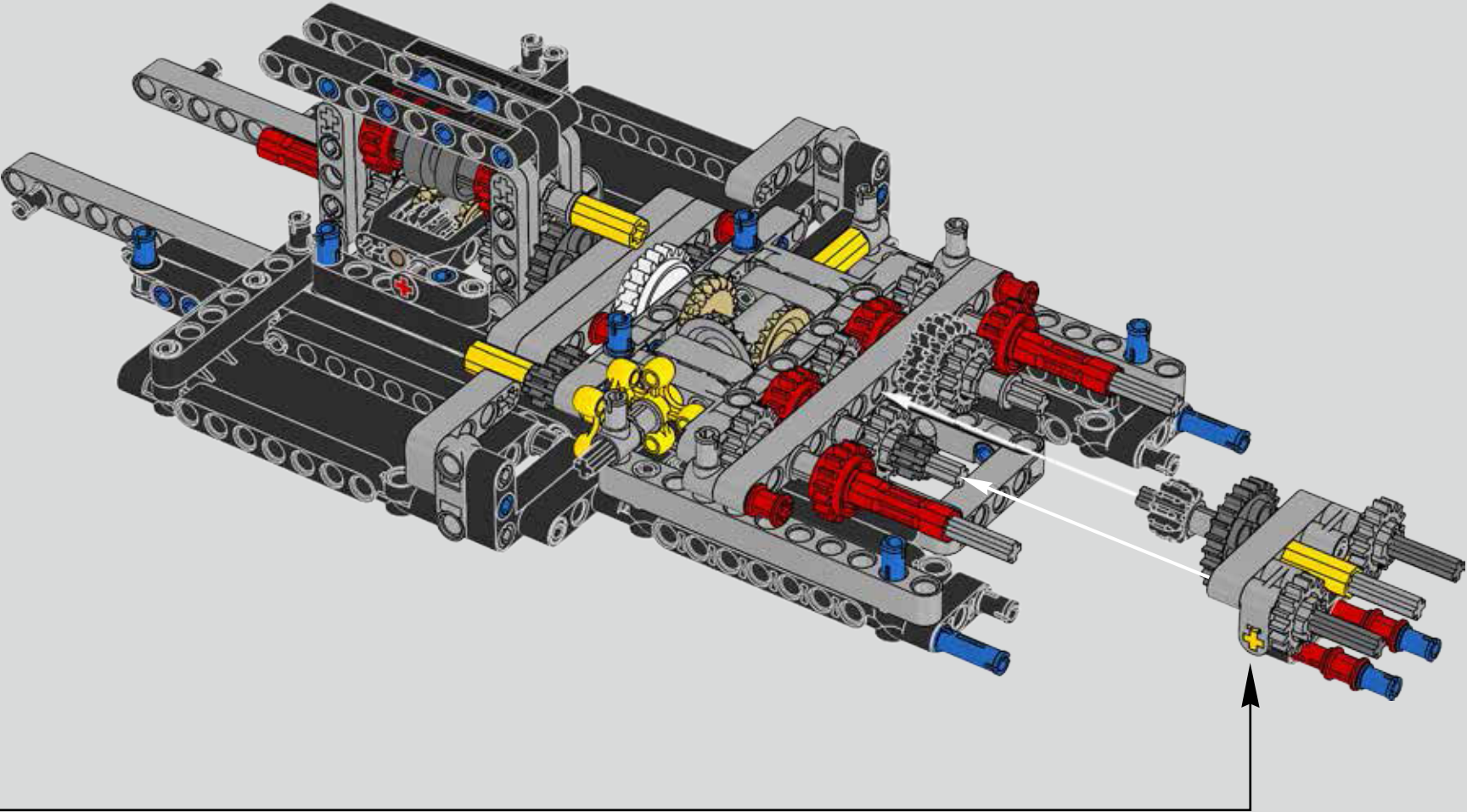

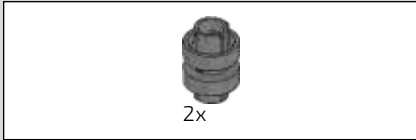

97

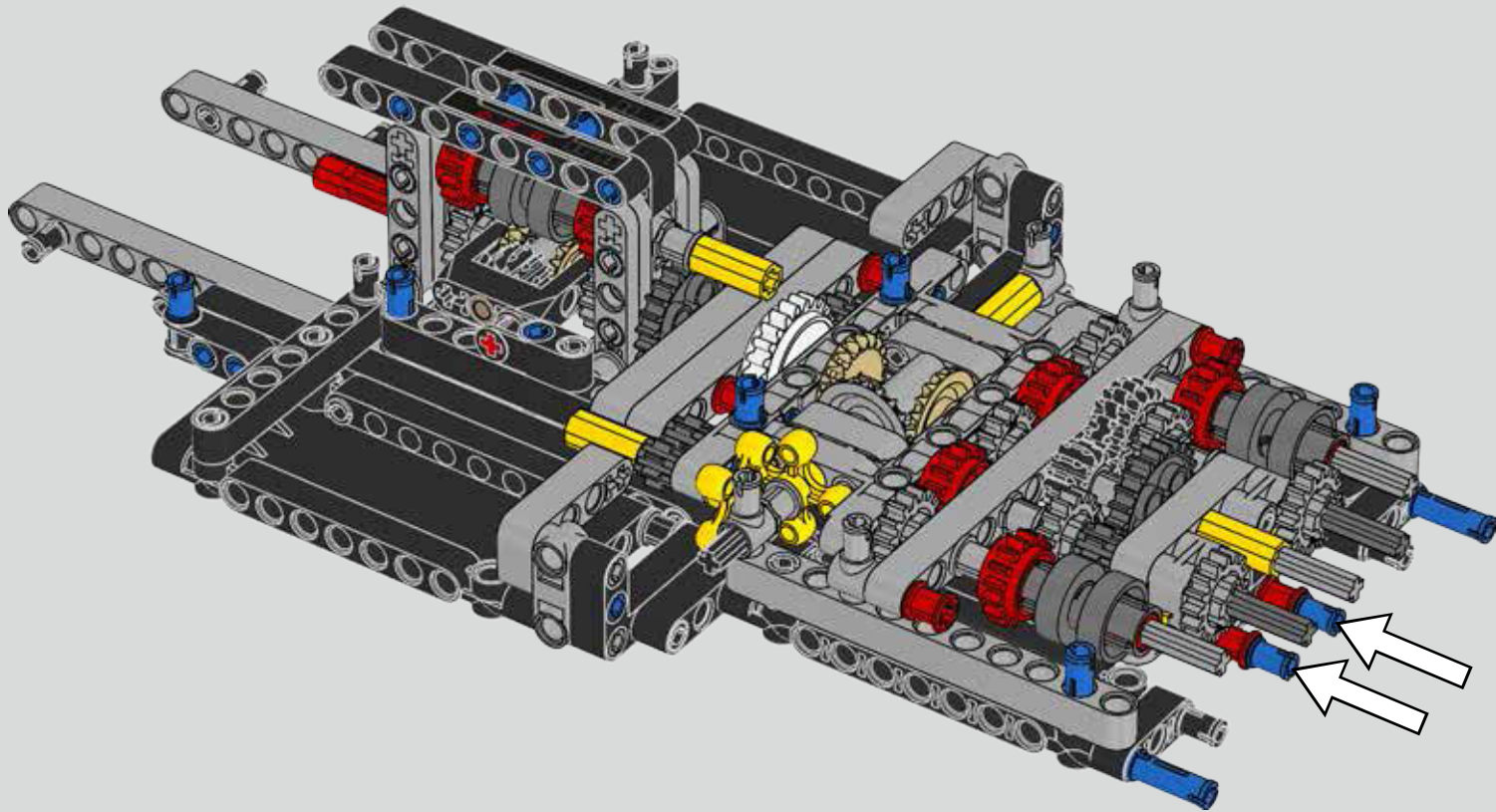

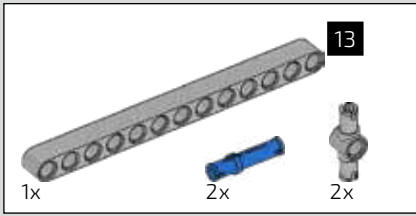

98

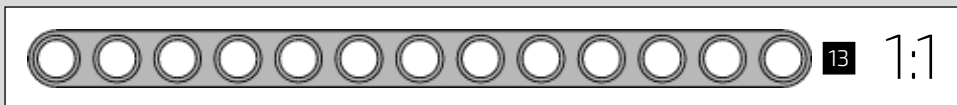
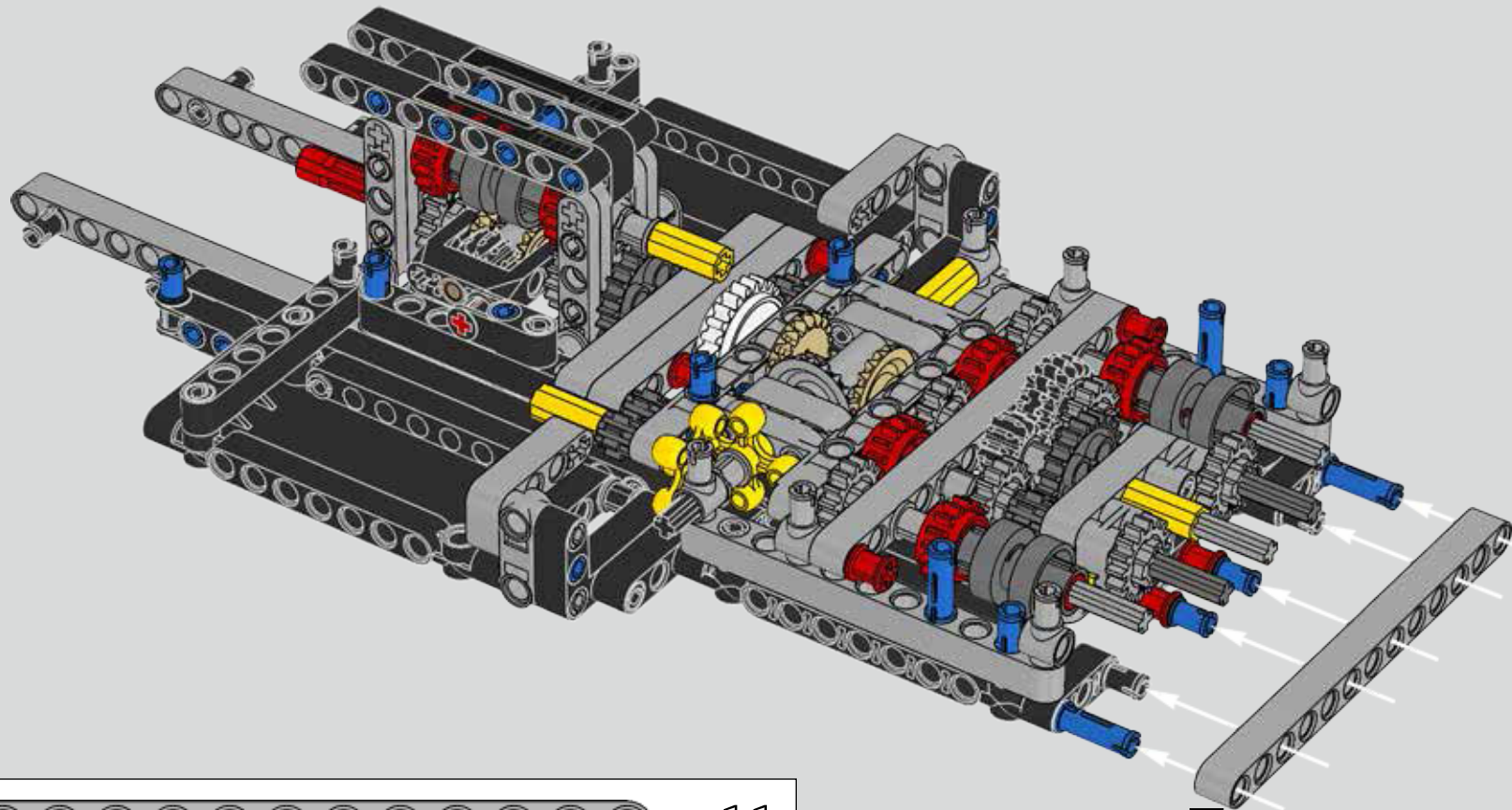

13

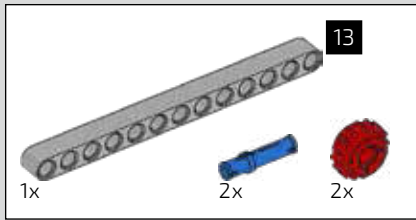

99

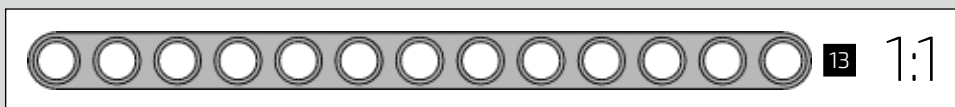
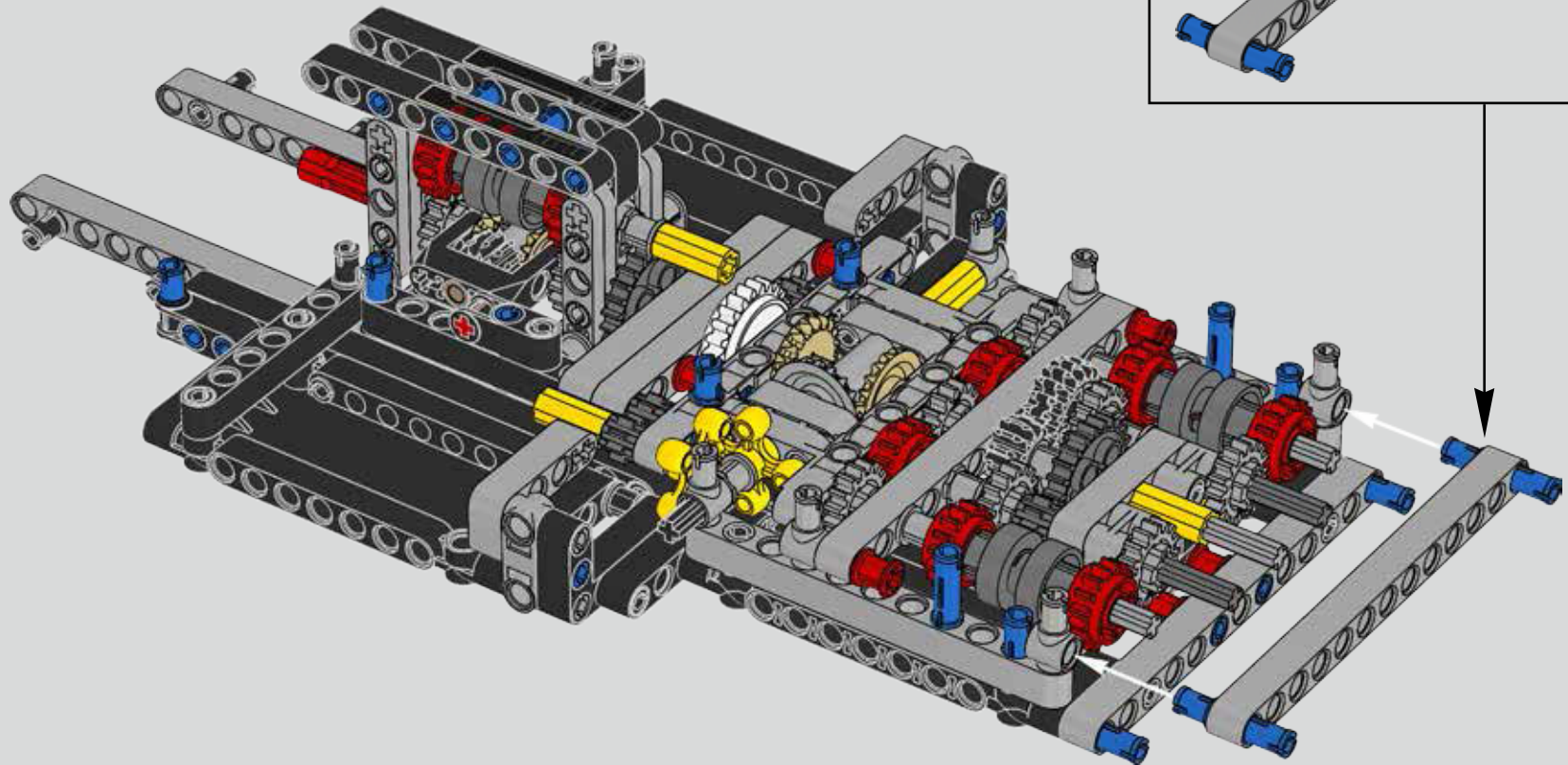
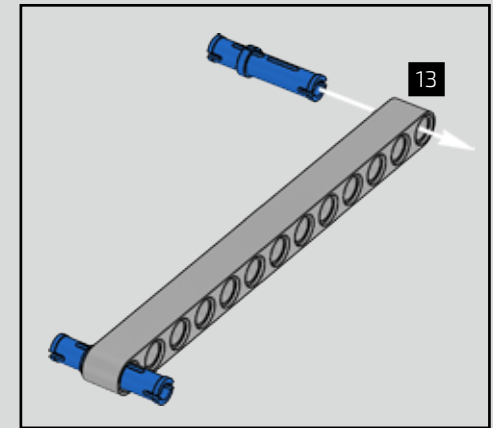

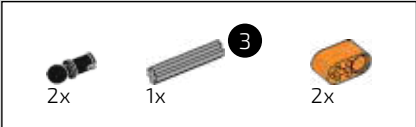

100

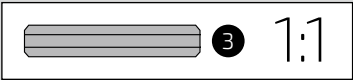
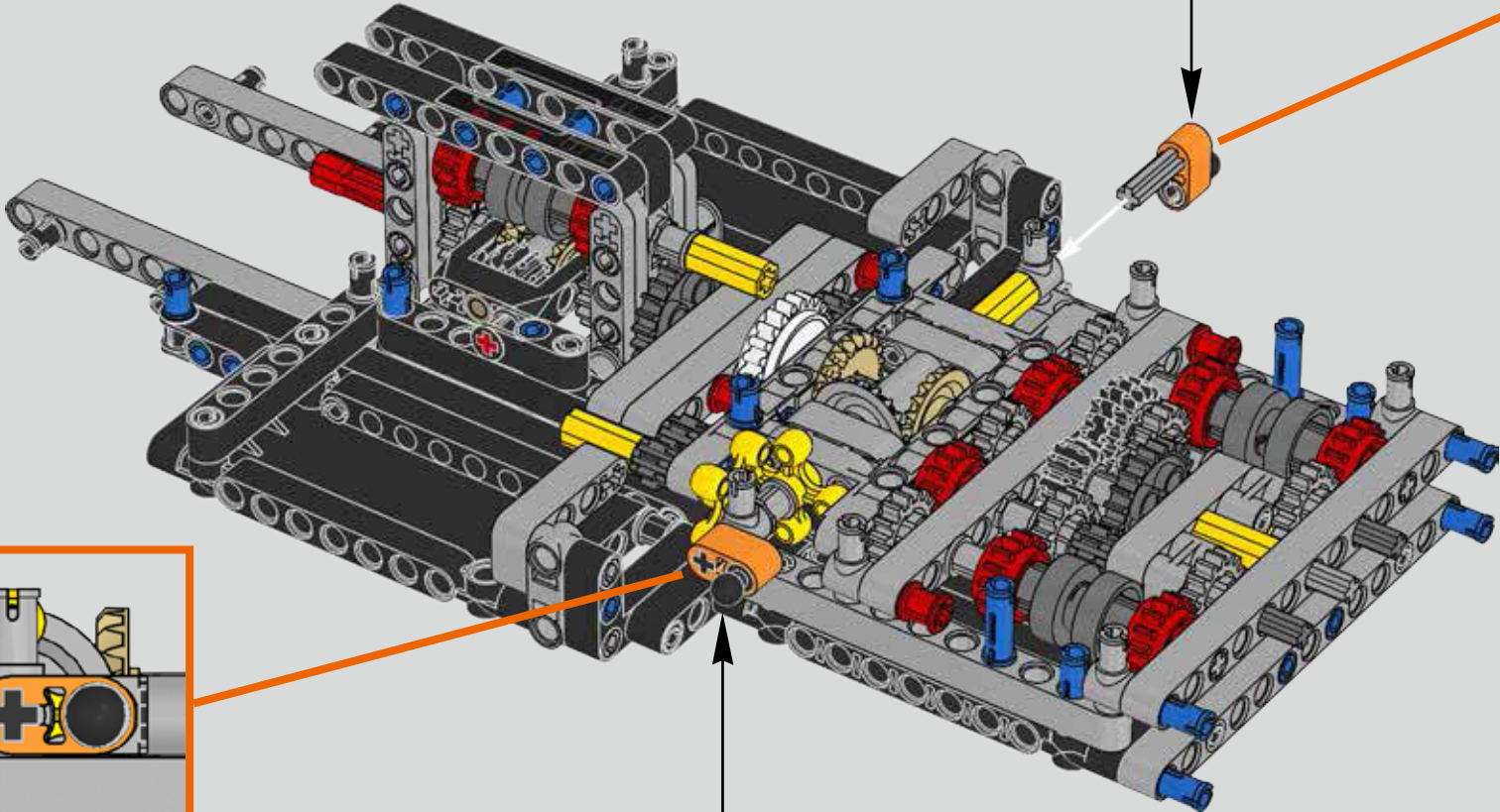
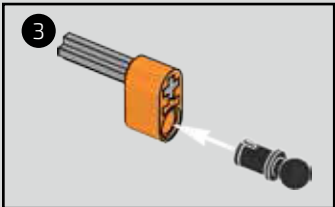

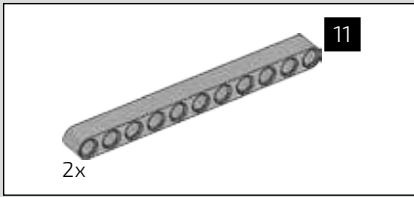

101

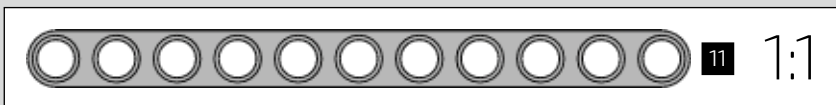
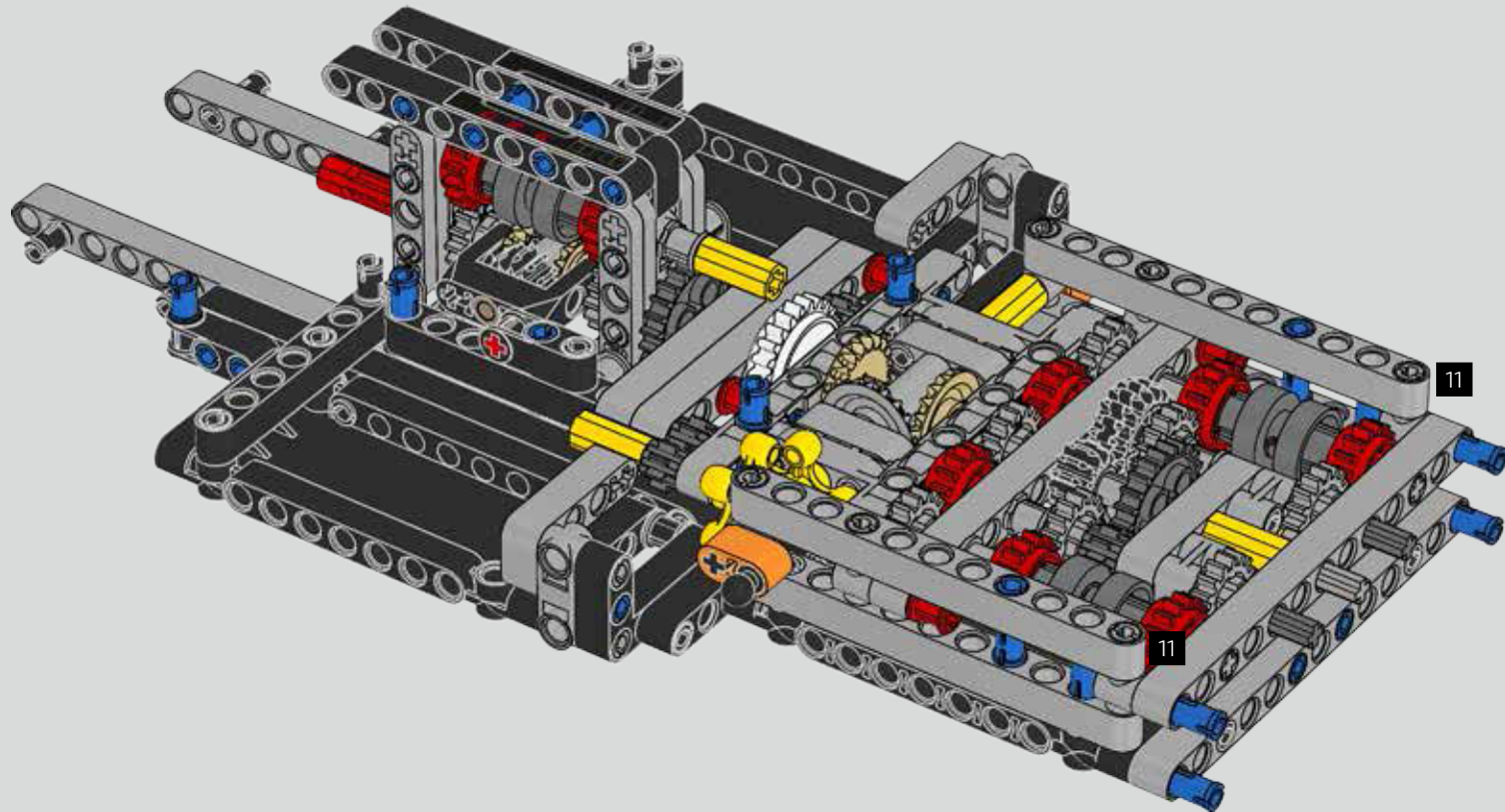

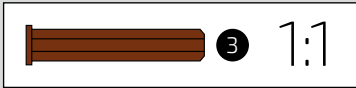

102

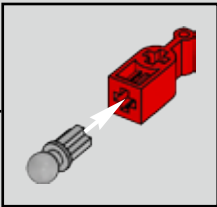
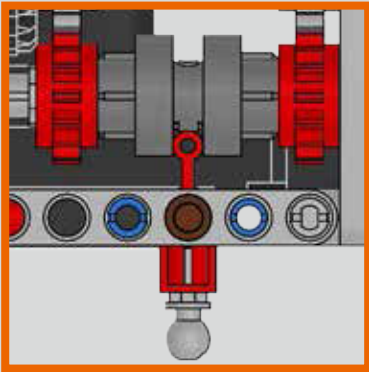
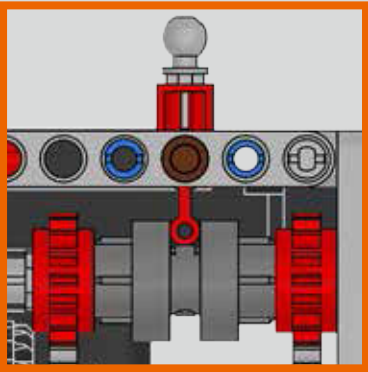
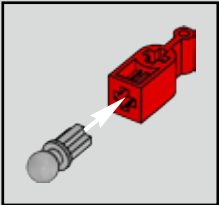
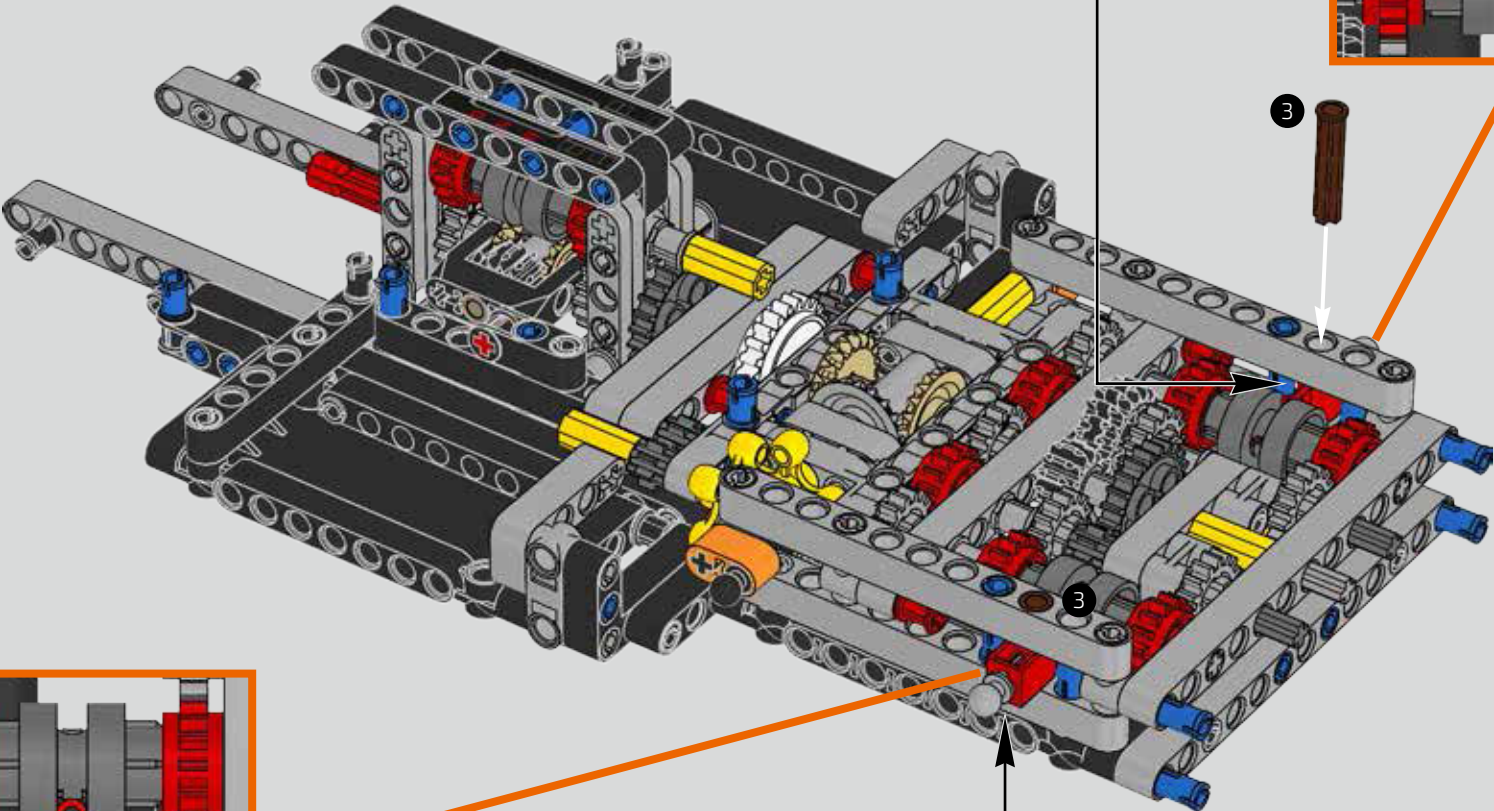

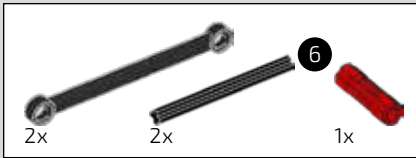

103

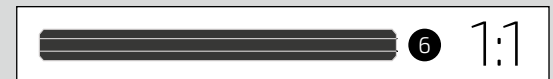
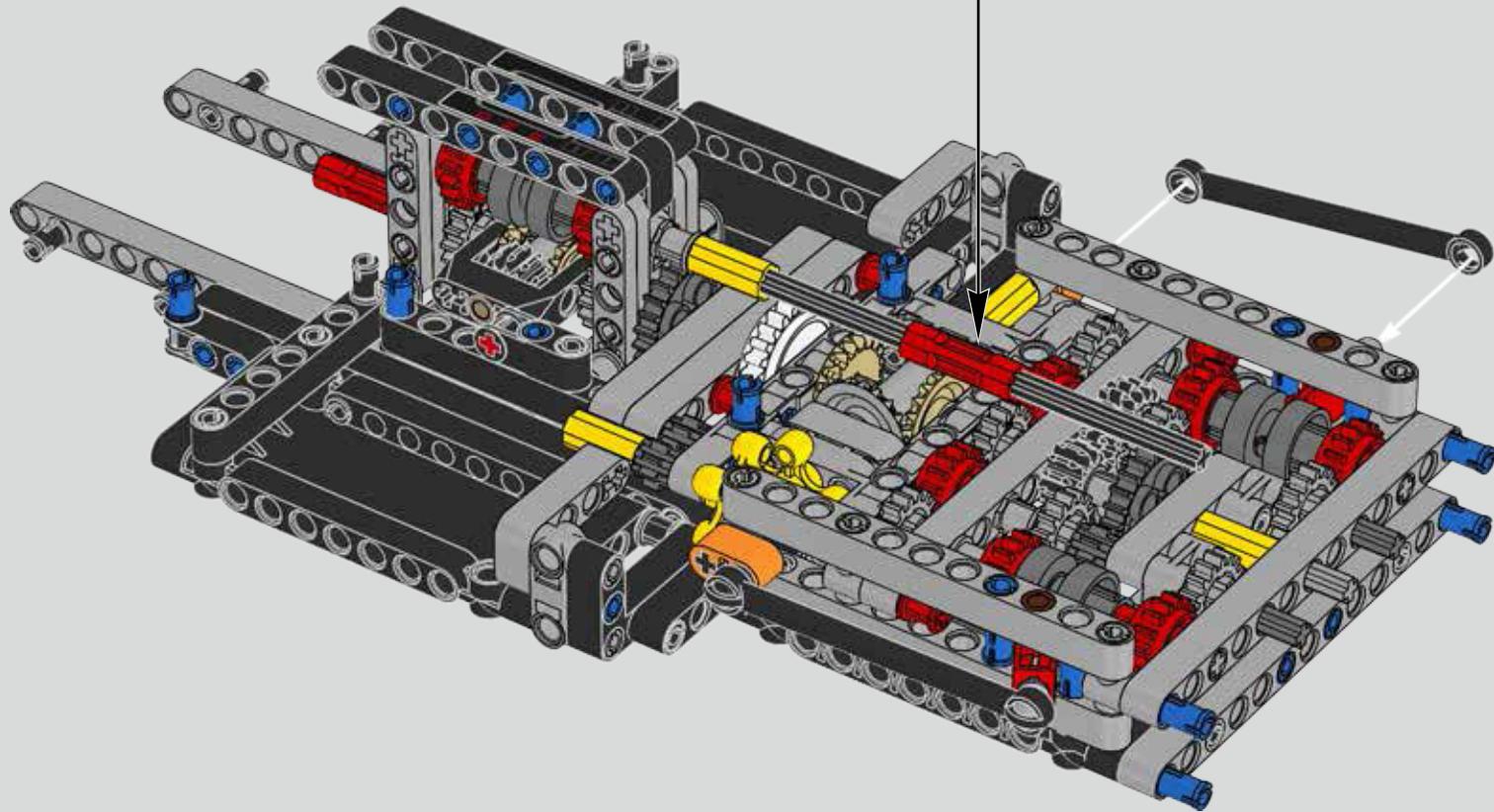
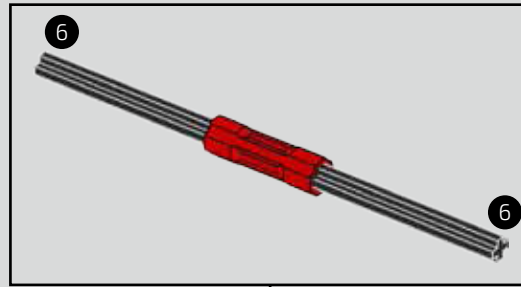

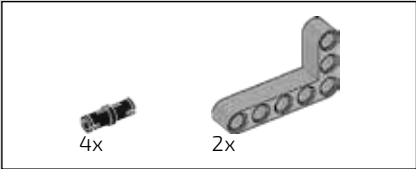

104

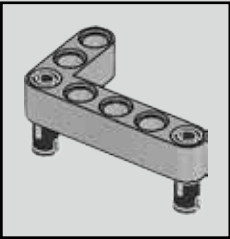
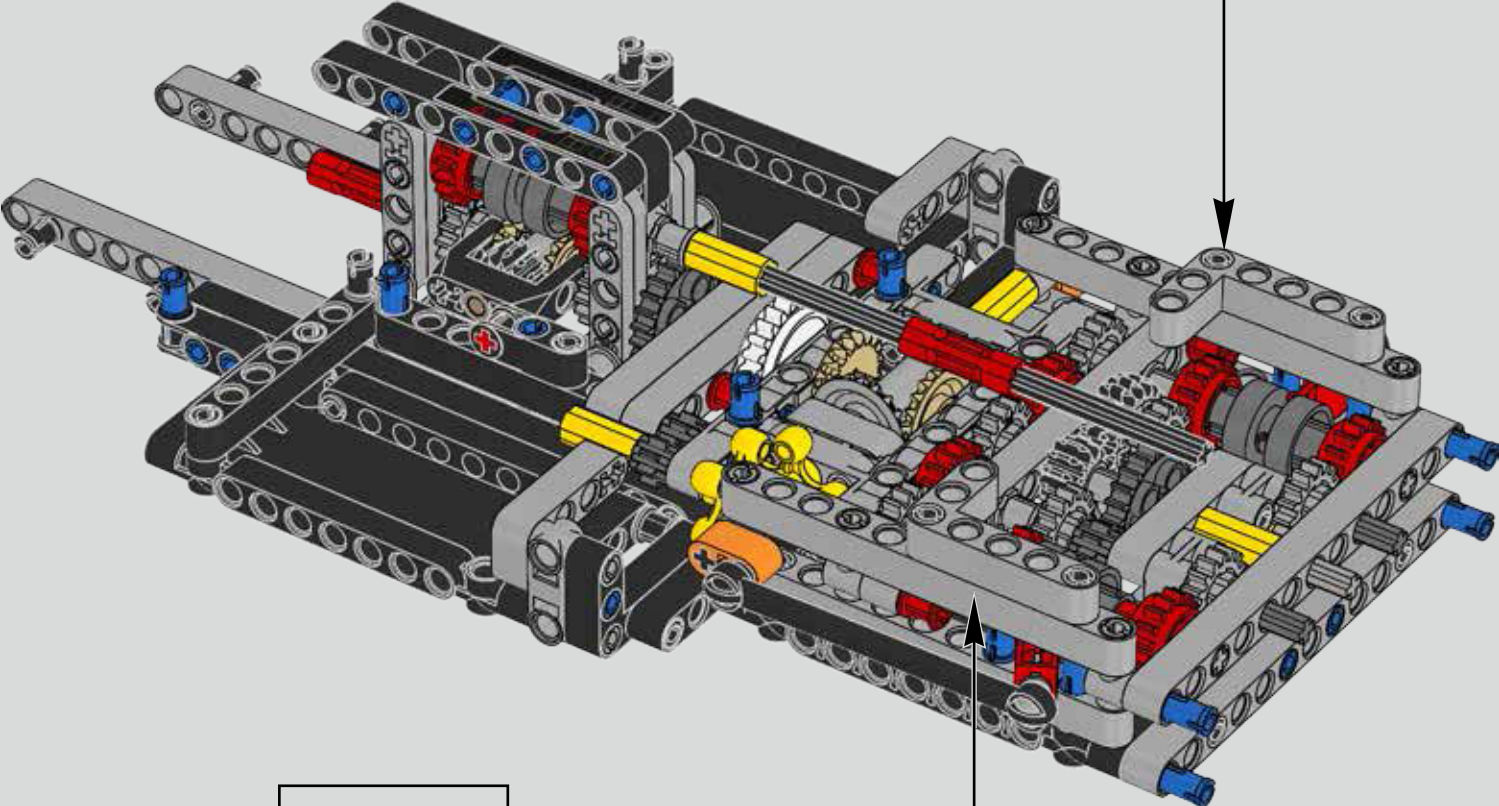
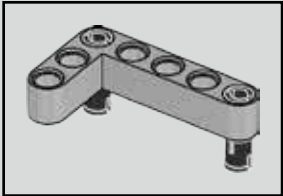



105

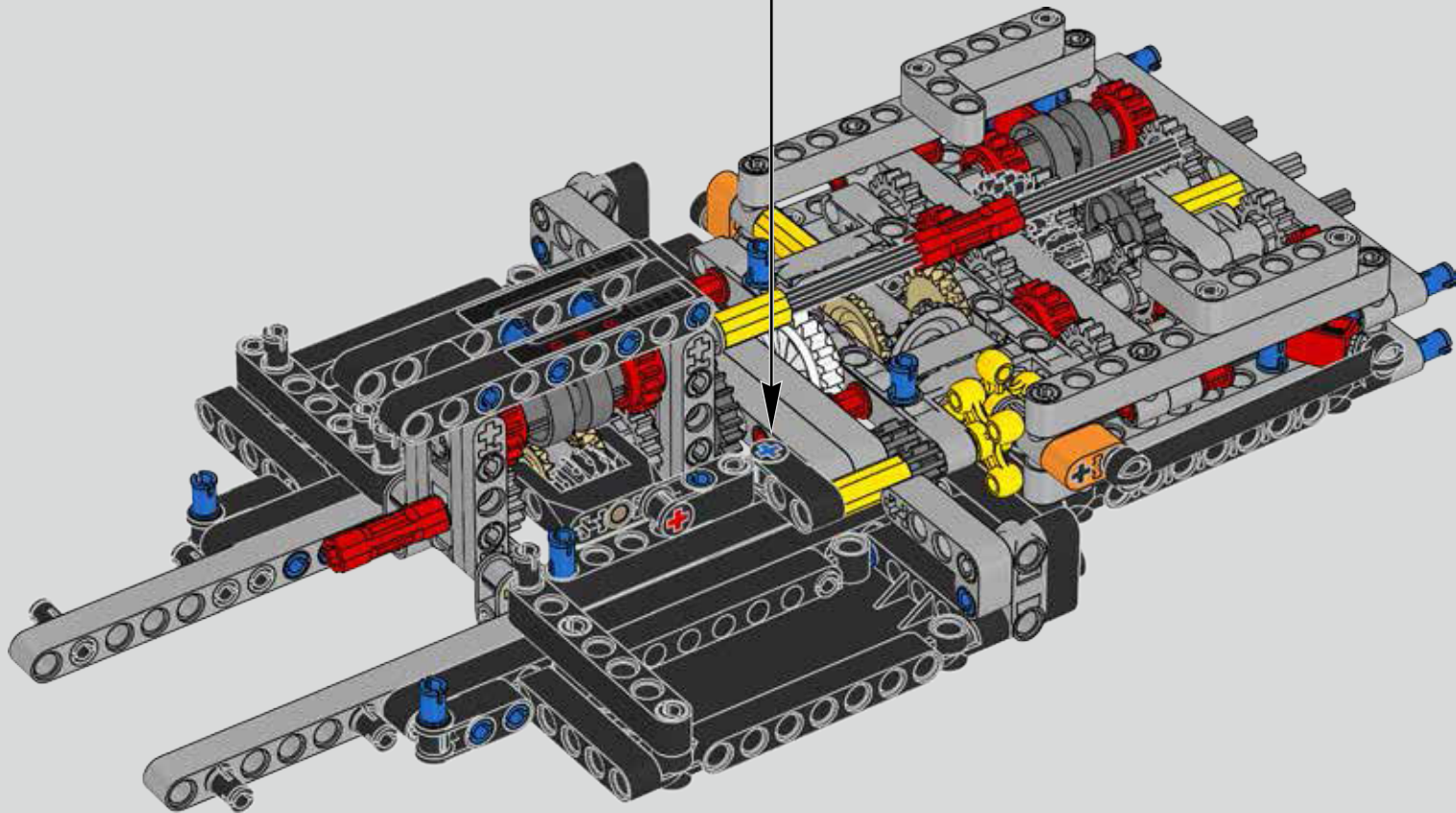

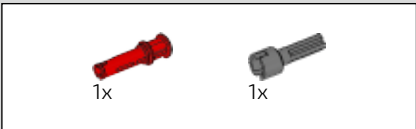

106

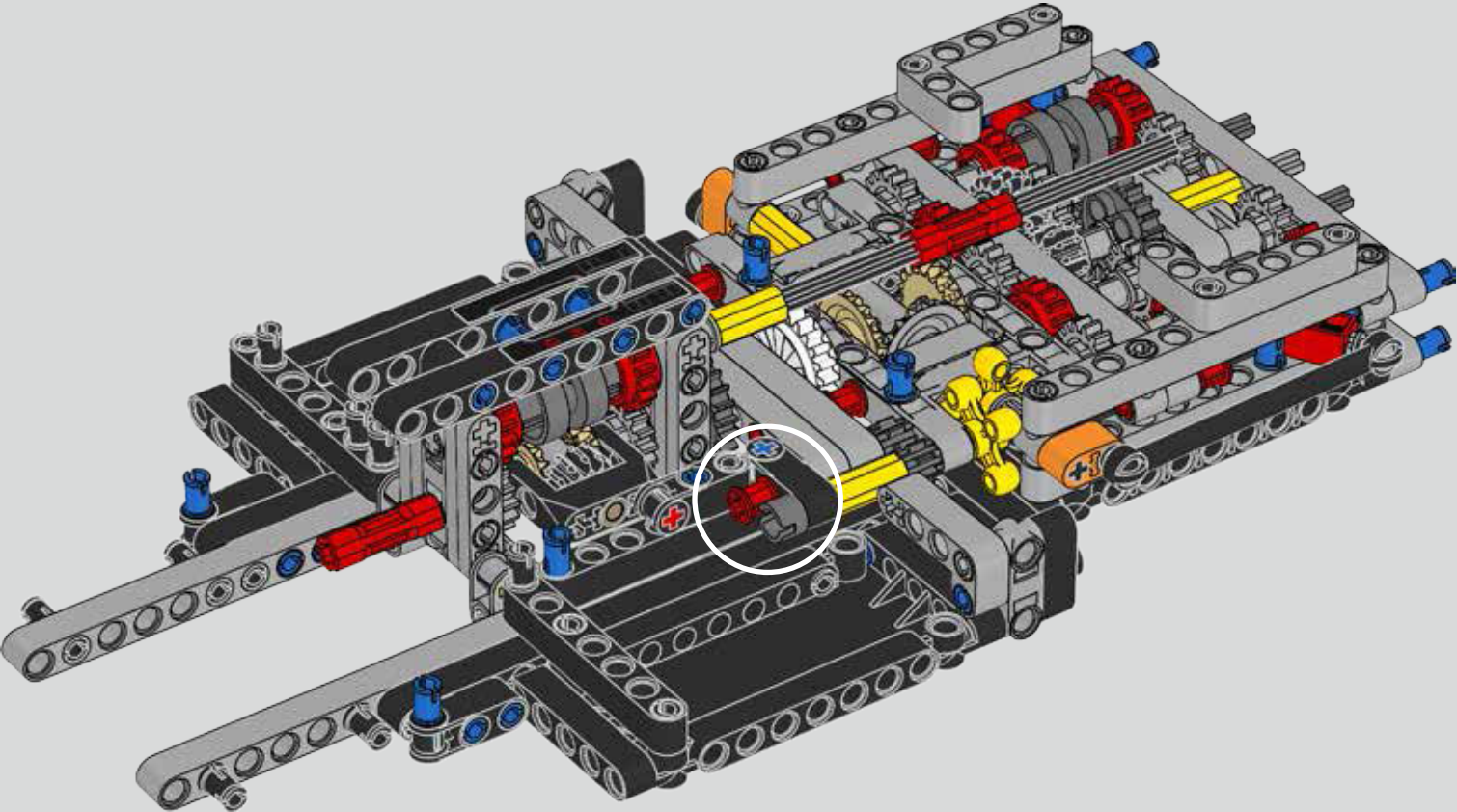

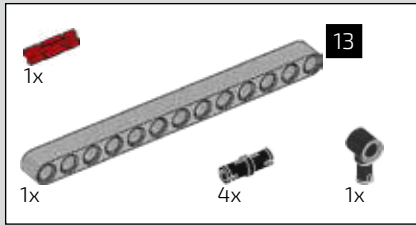

107

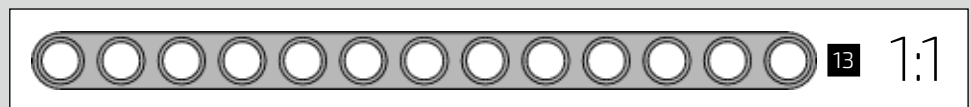
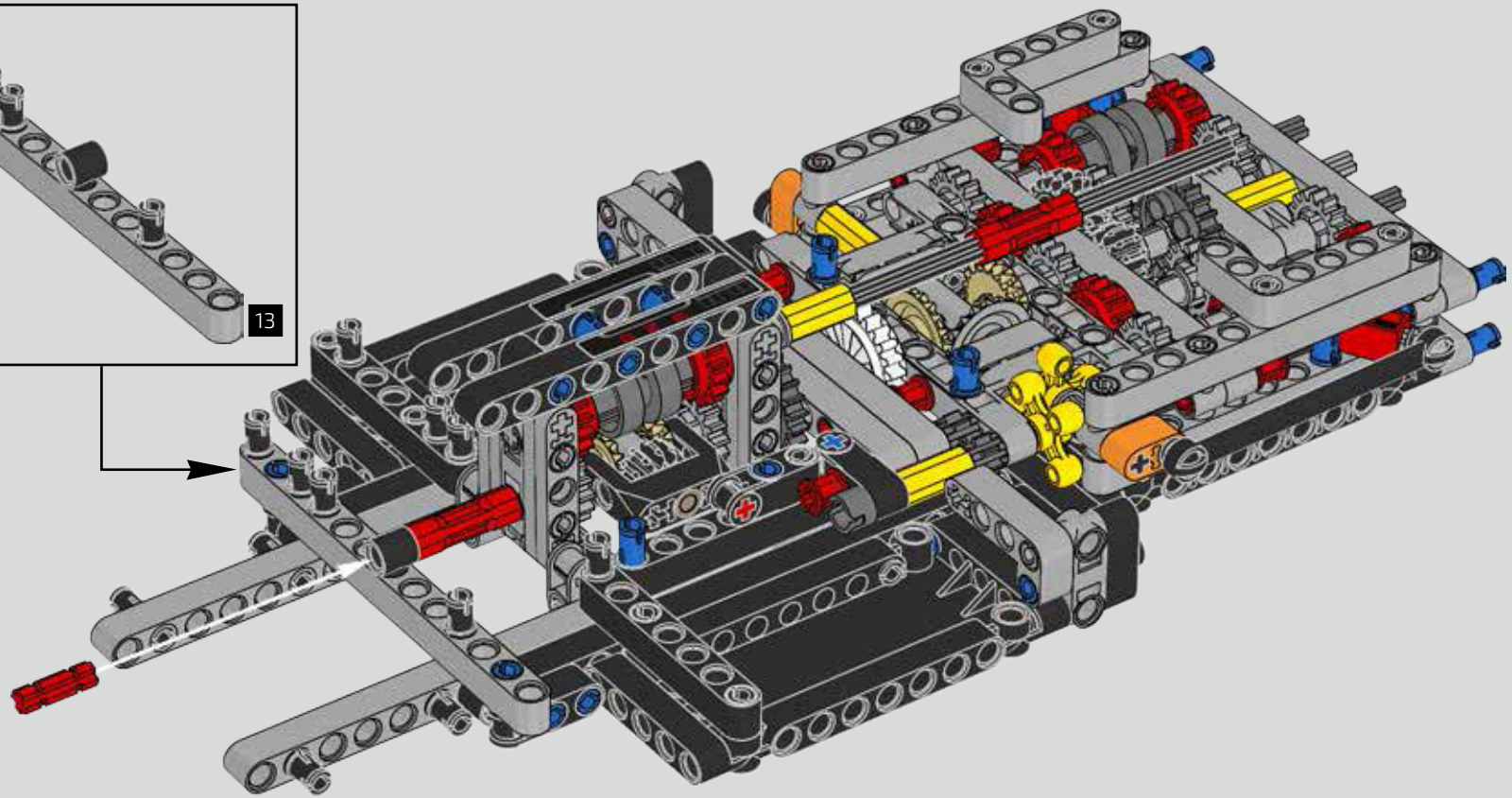
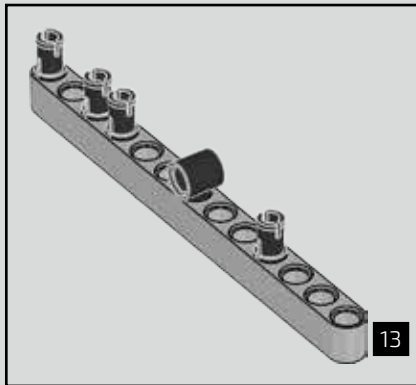

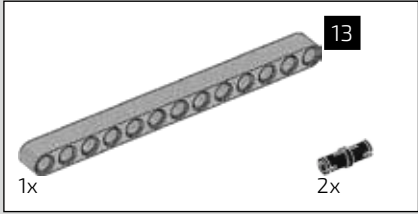
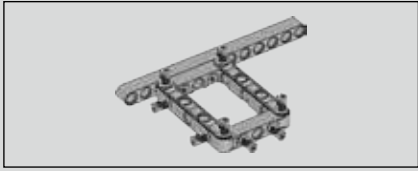

108

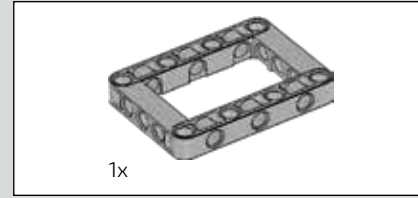
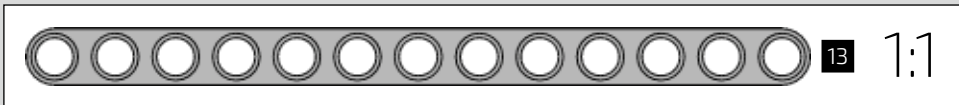
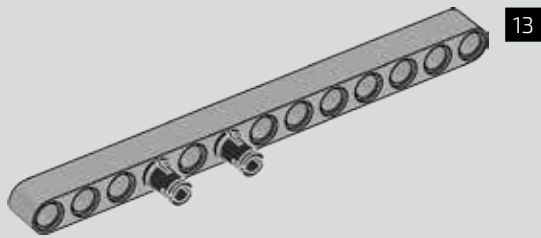

109

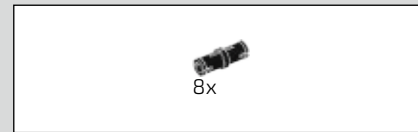
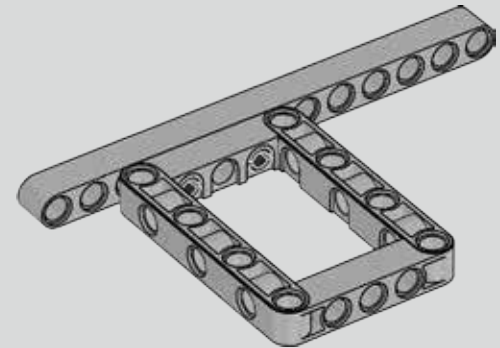

110

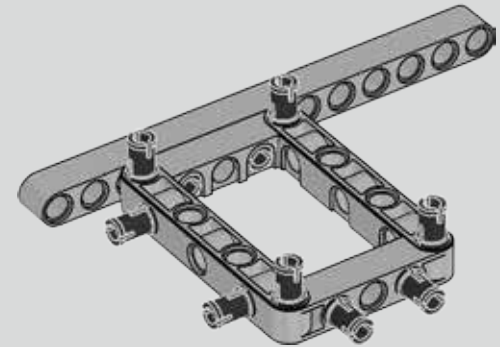

111

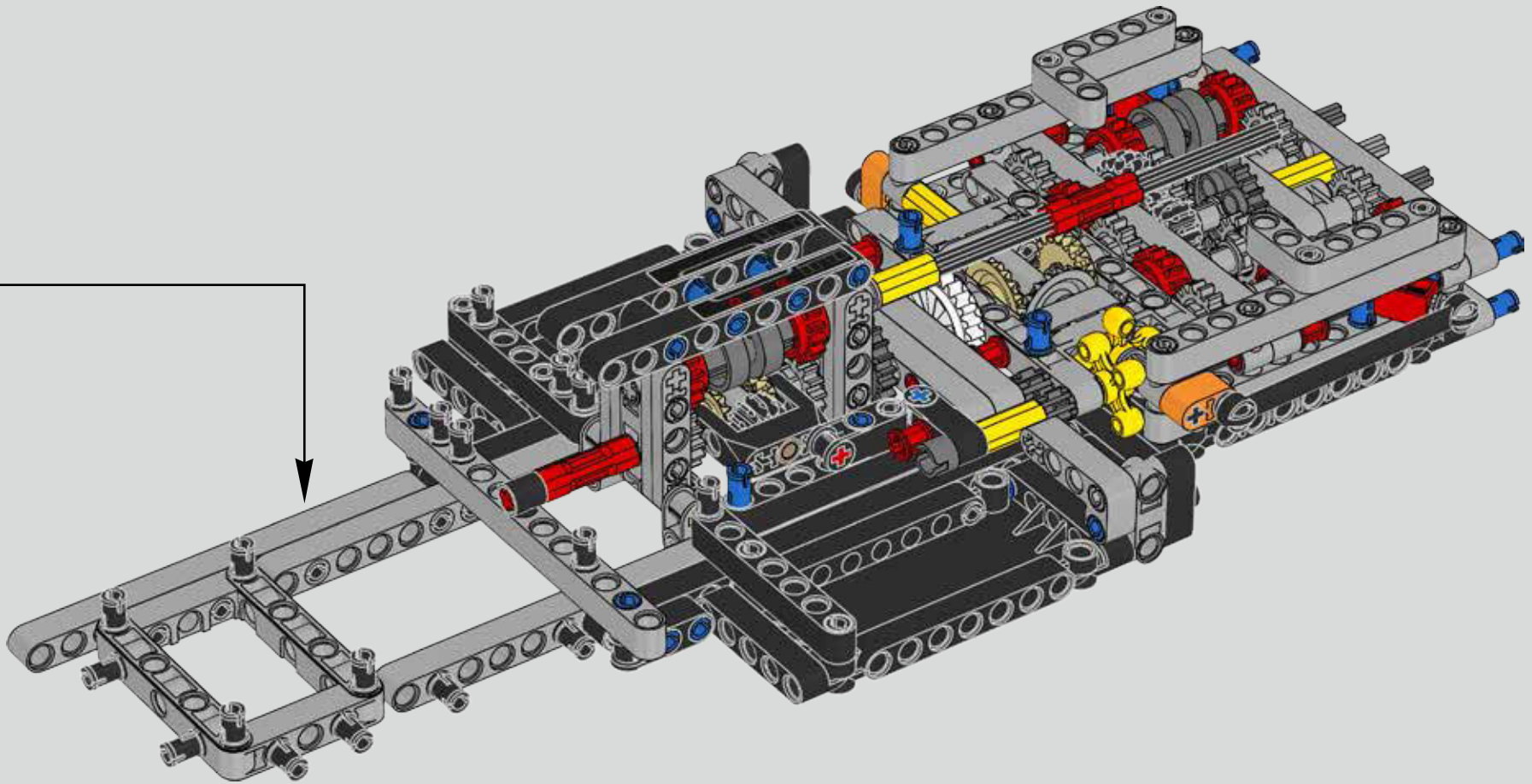

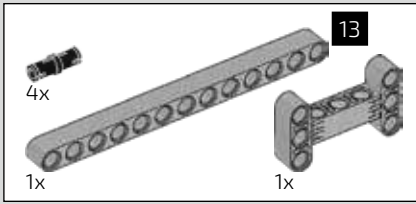

112

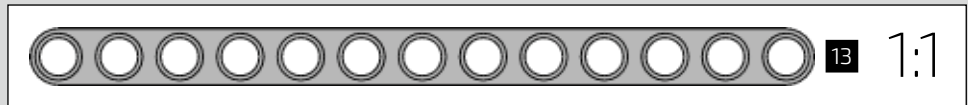
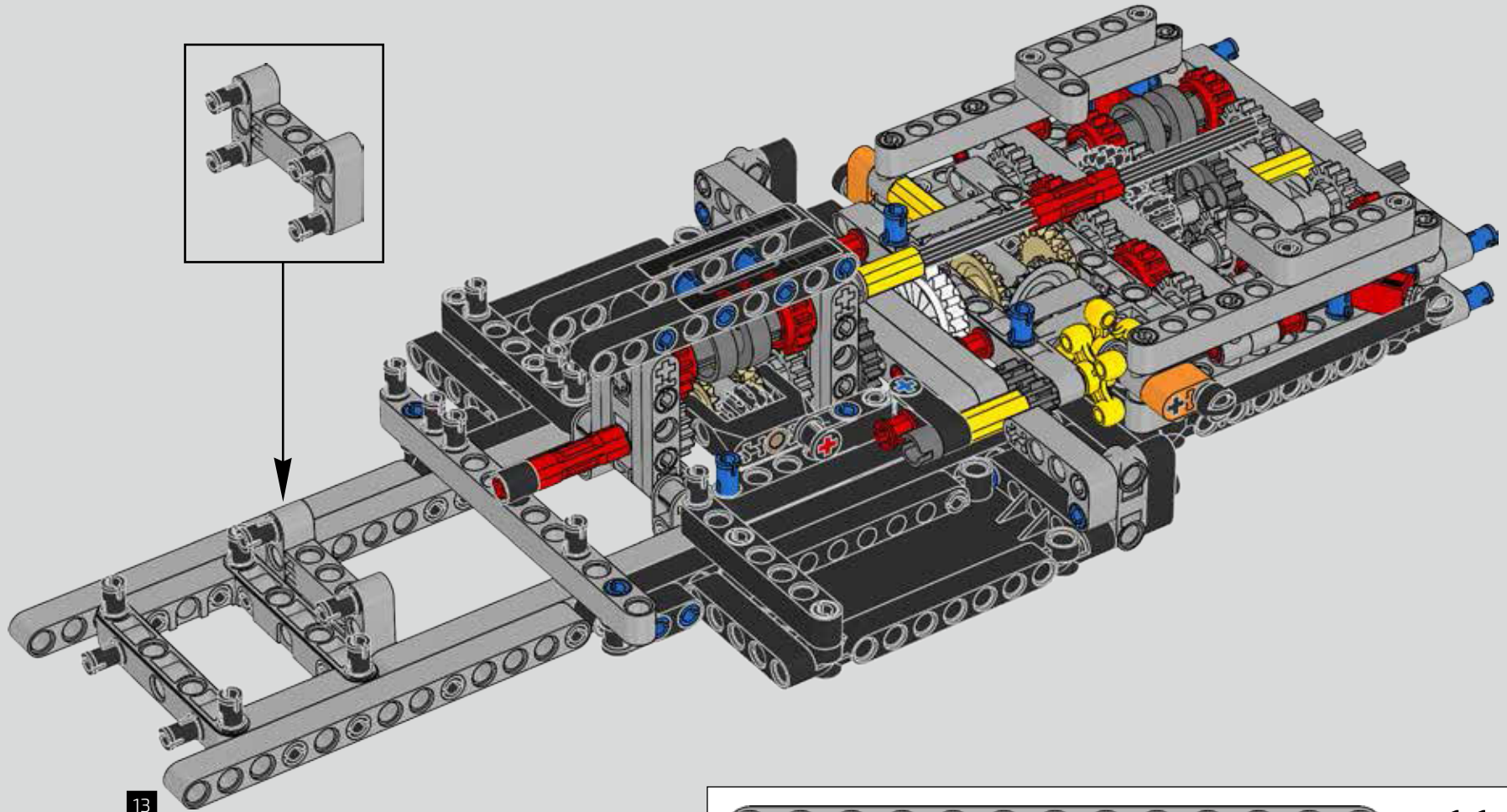
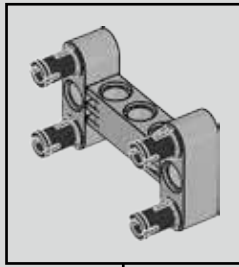

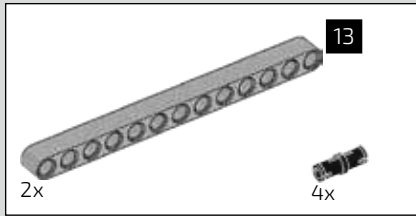

113

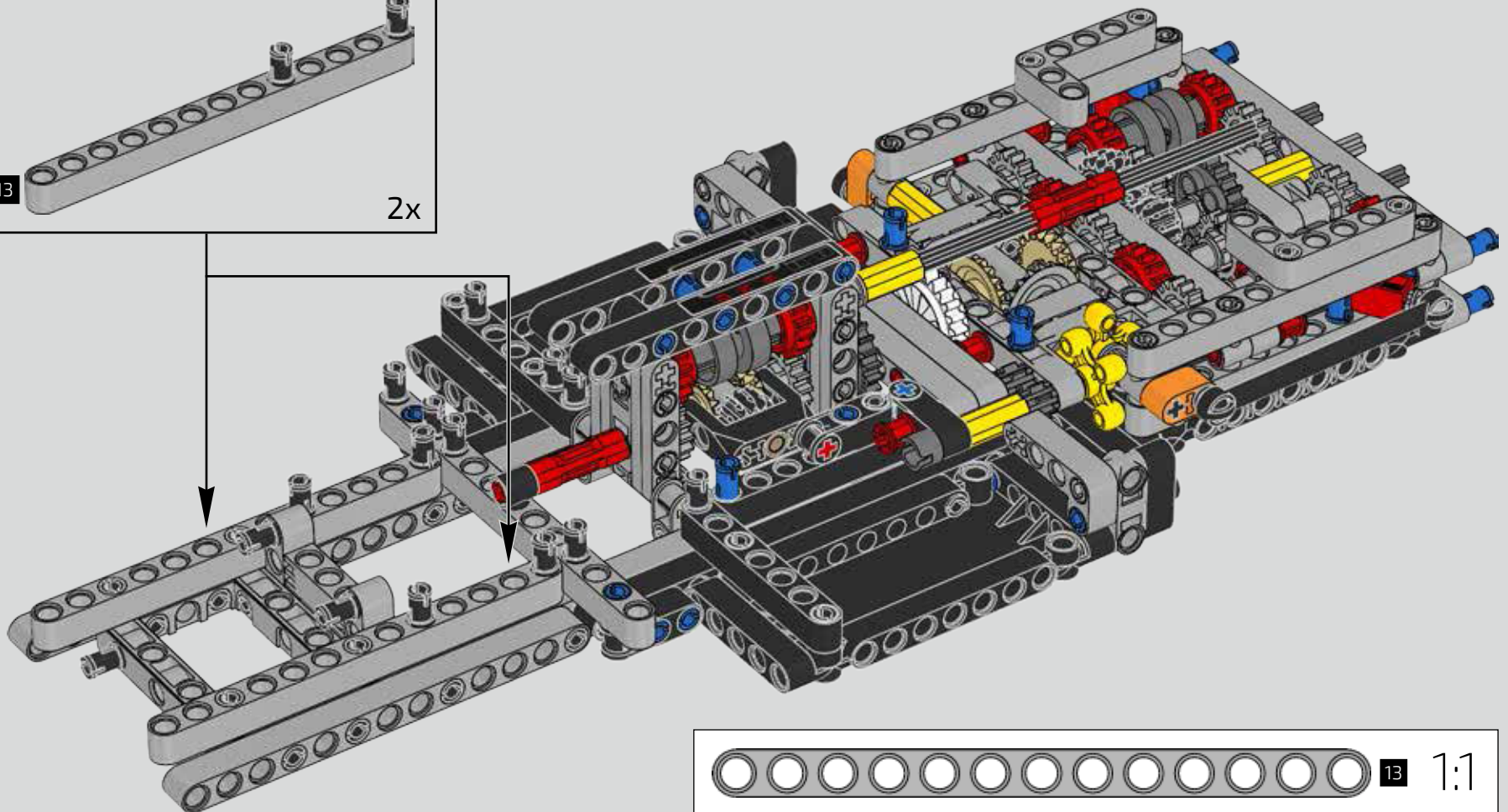
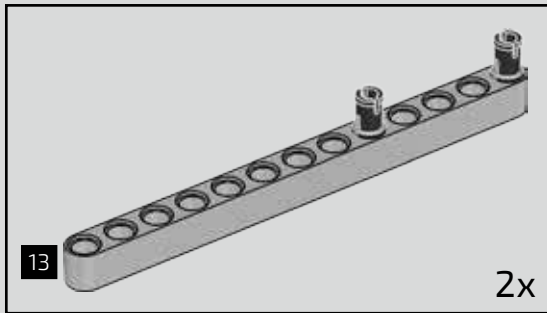

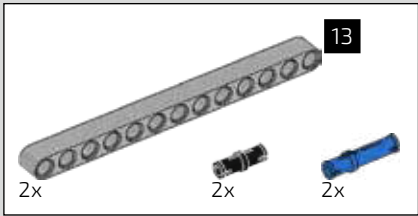

114

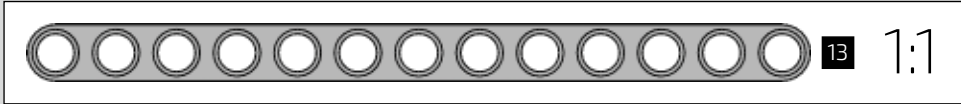
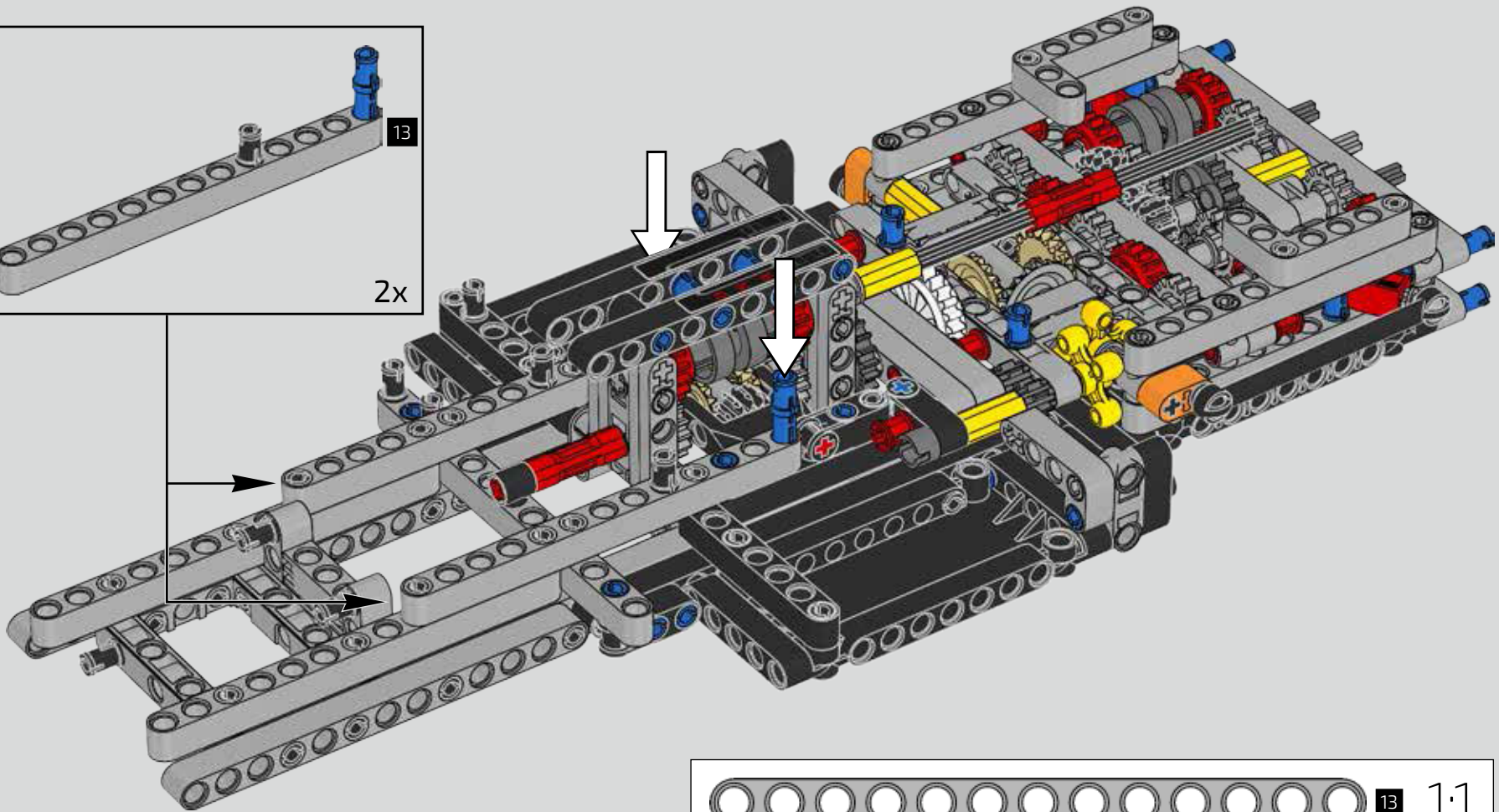
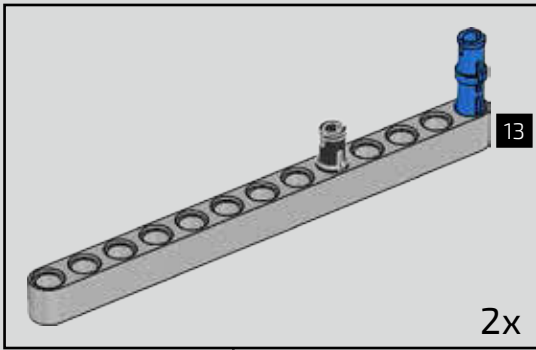

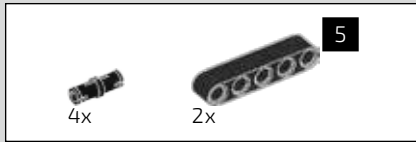

115

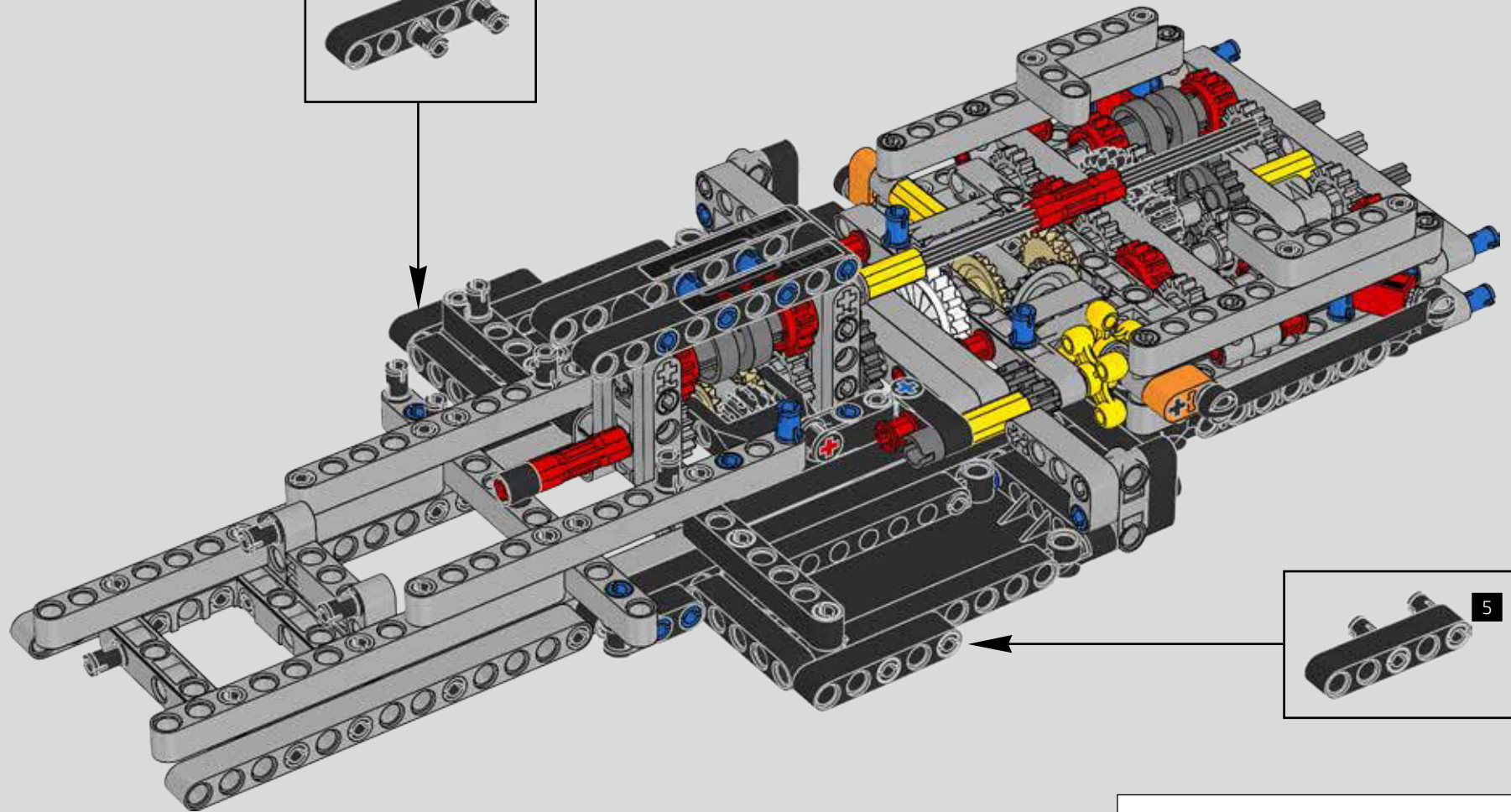
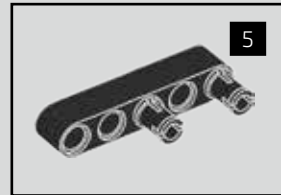

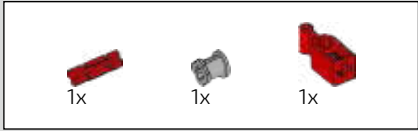

116

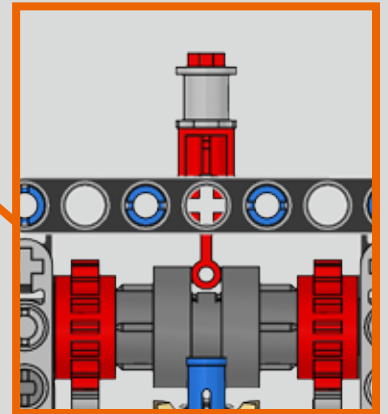
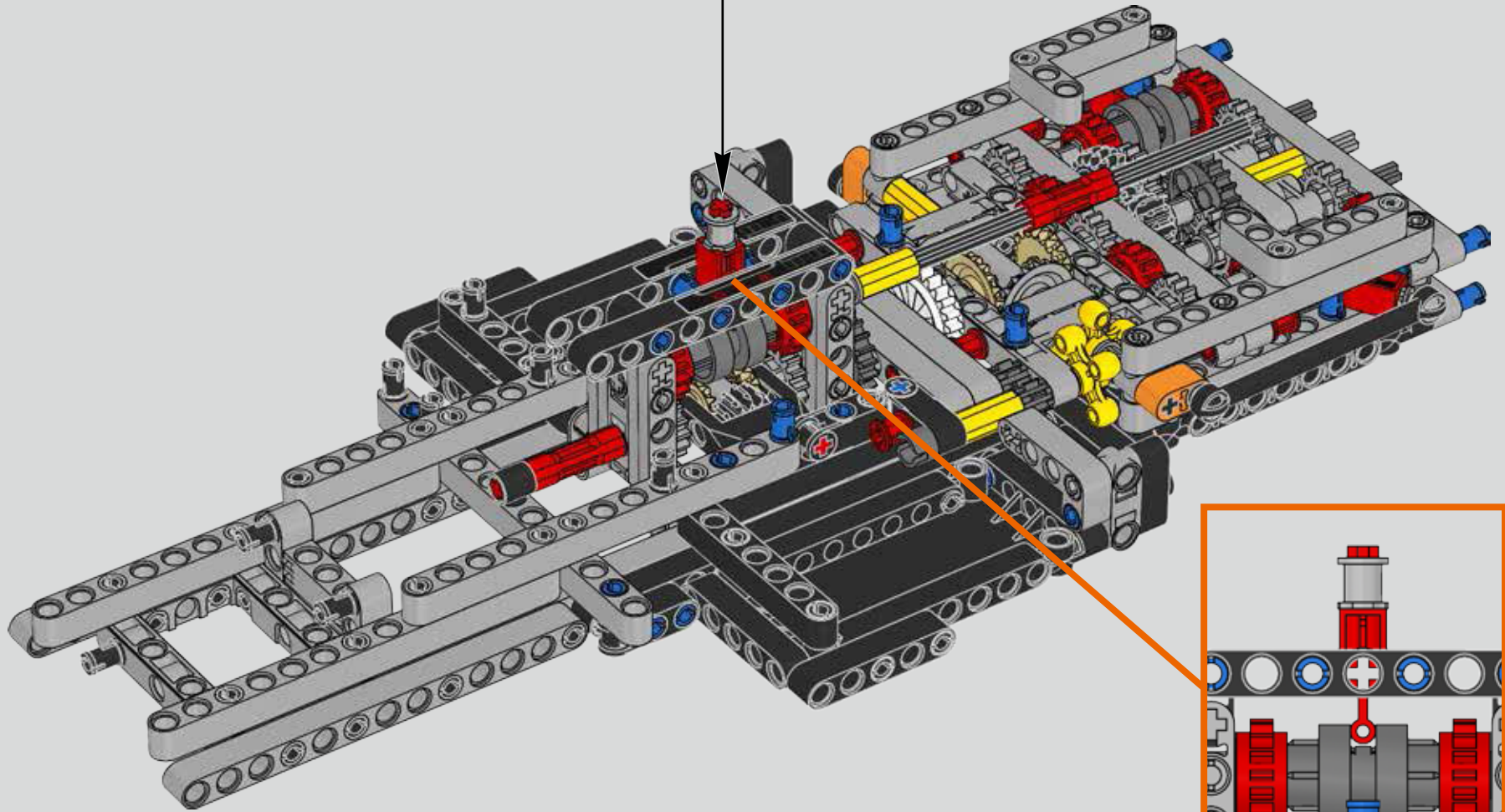
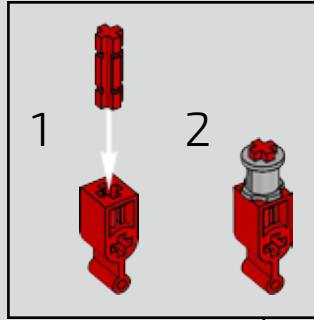

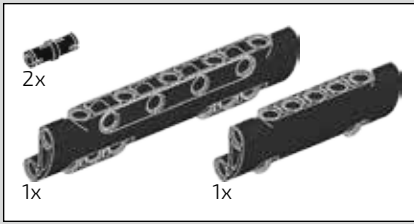

117

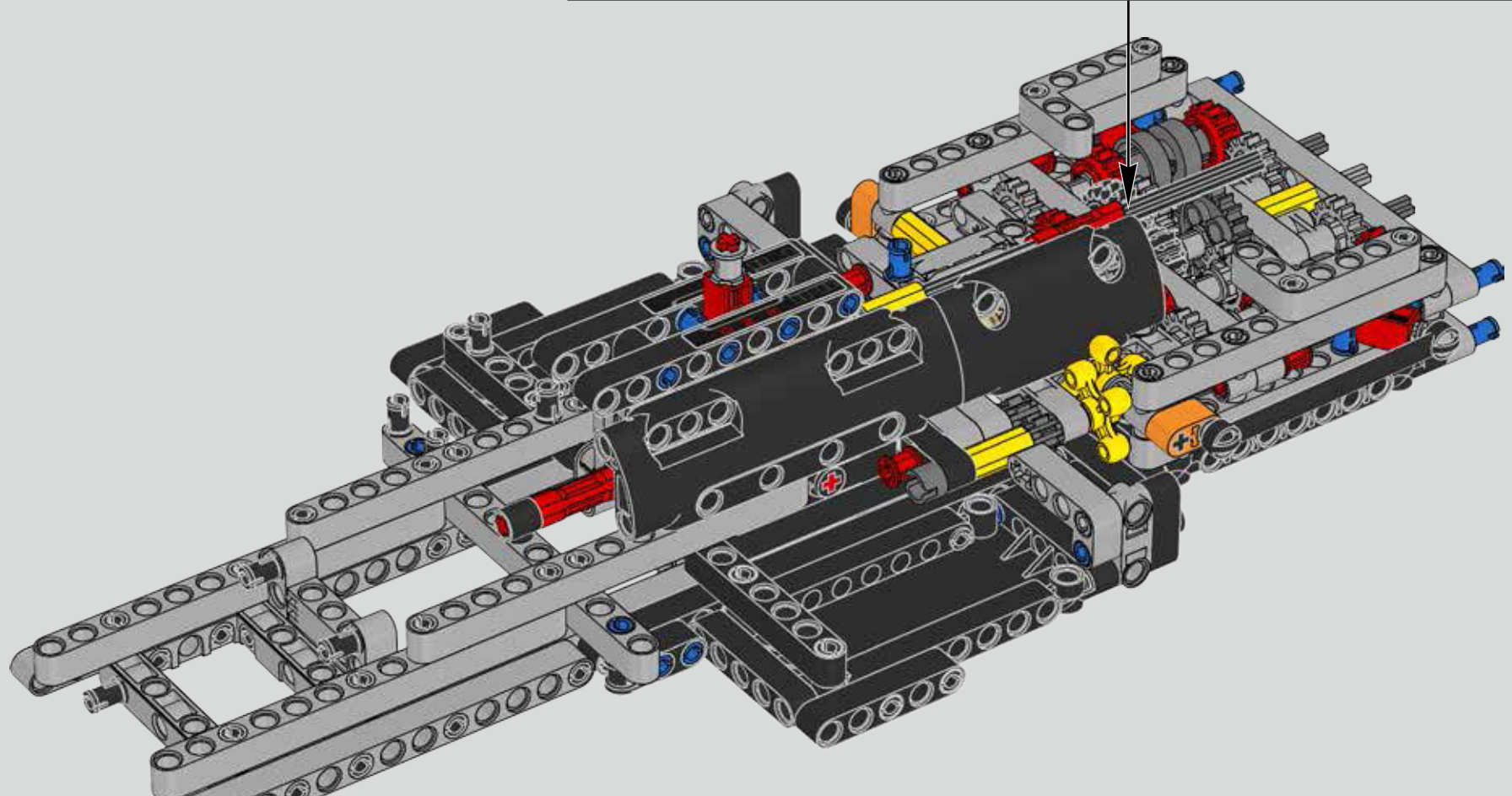
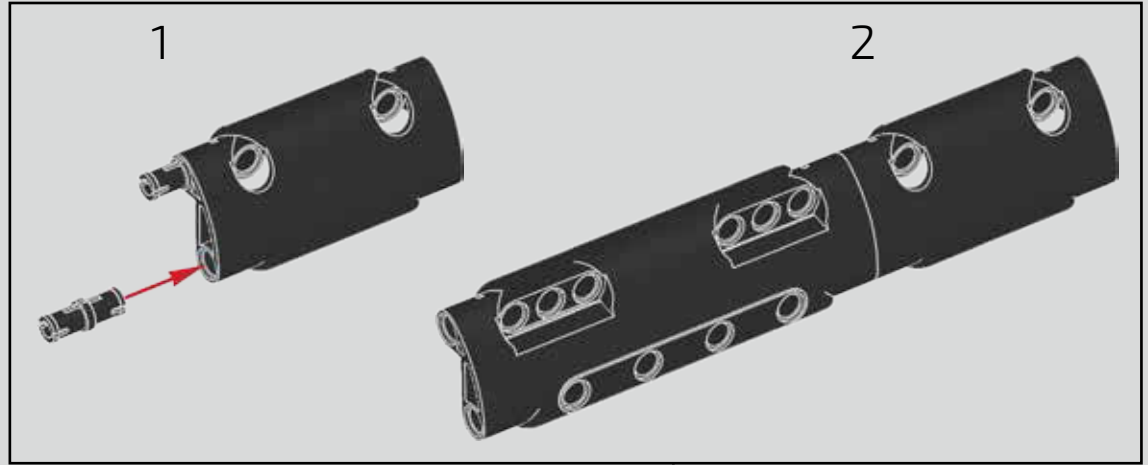

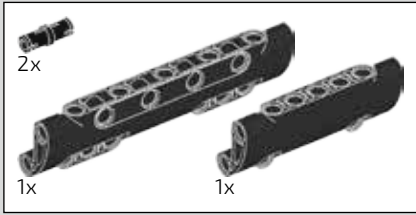

118

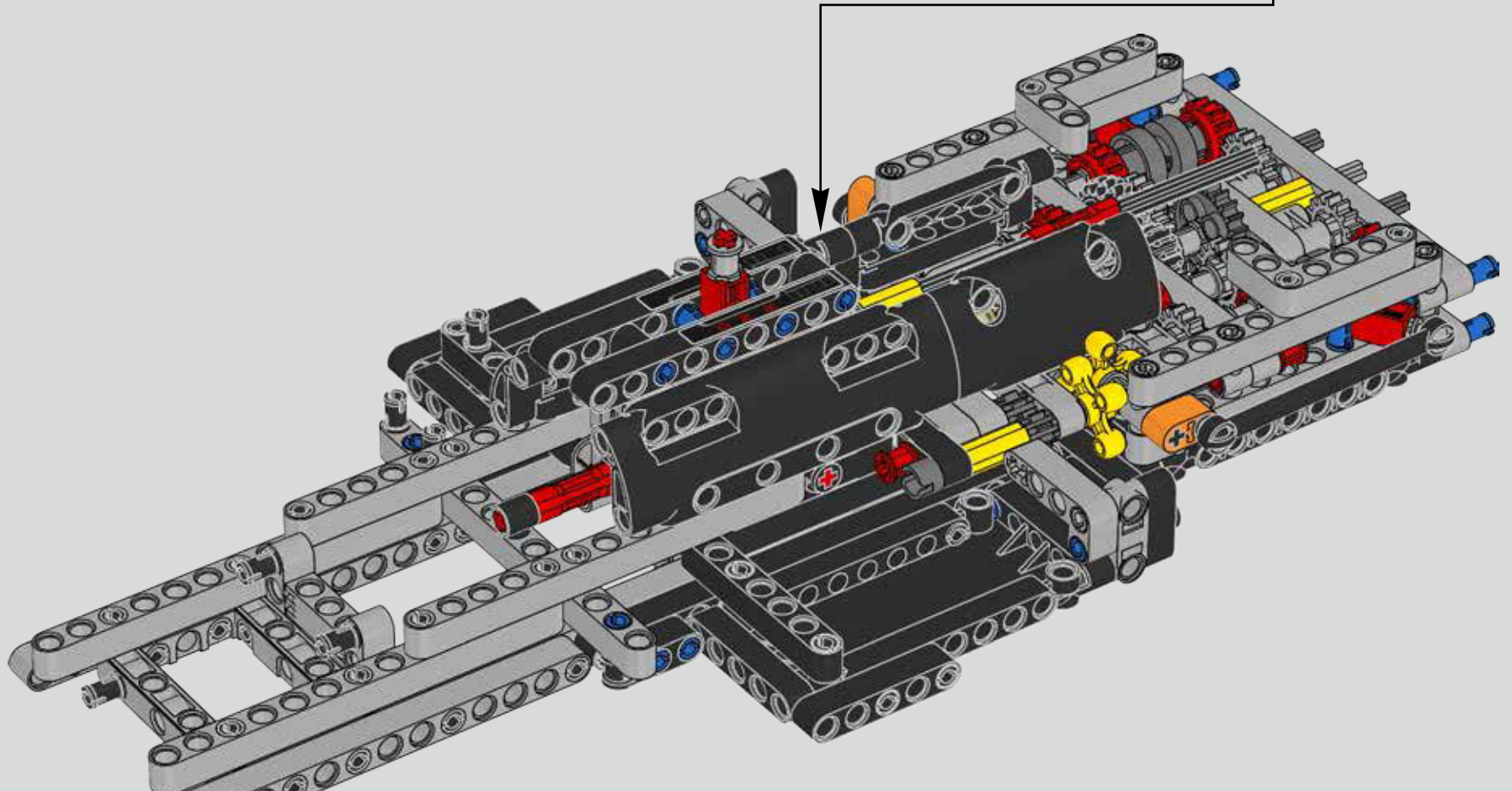
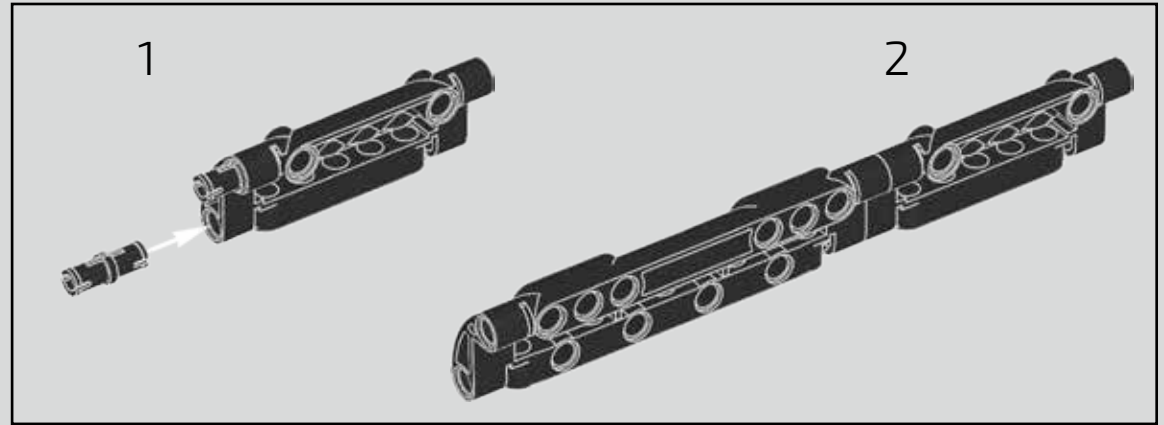

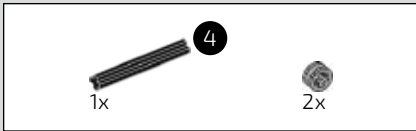

119

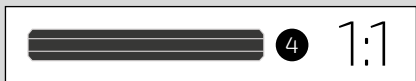
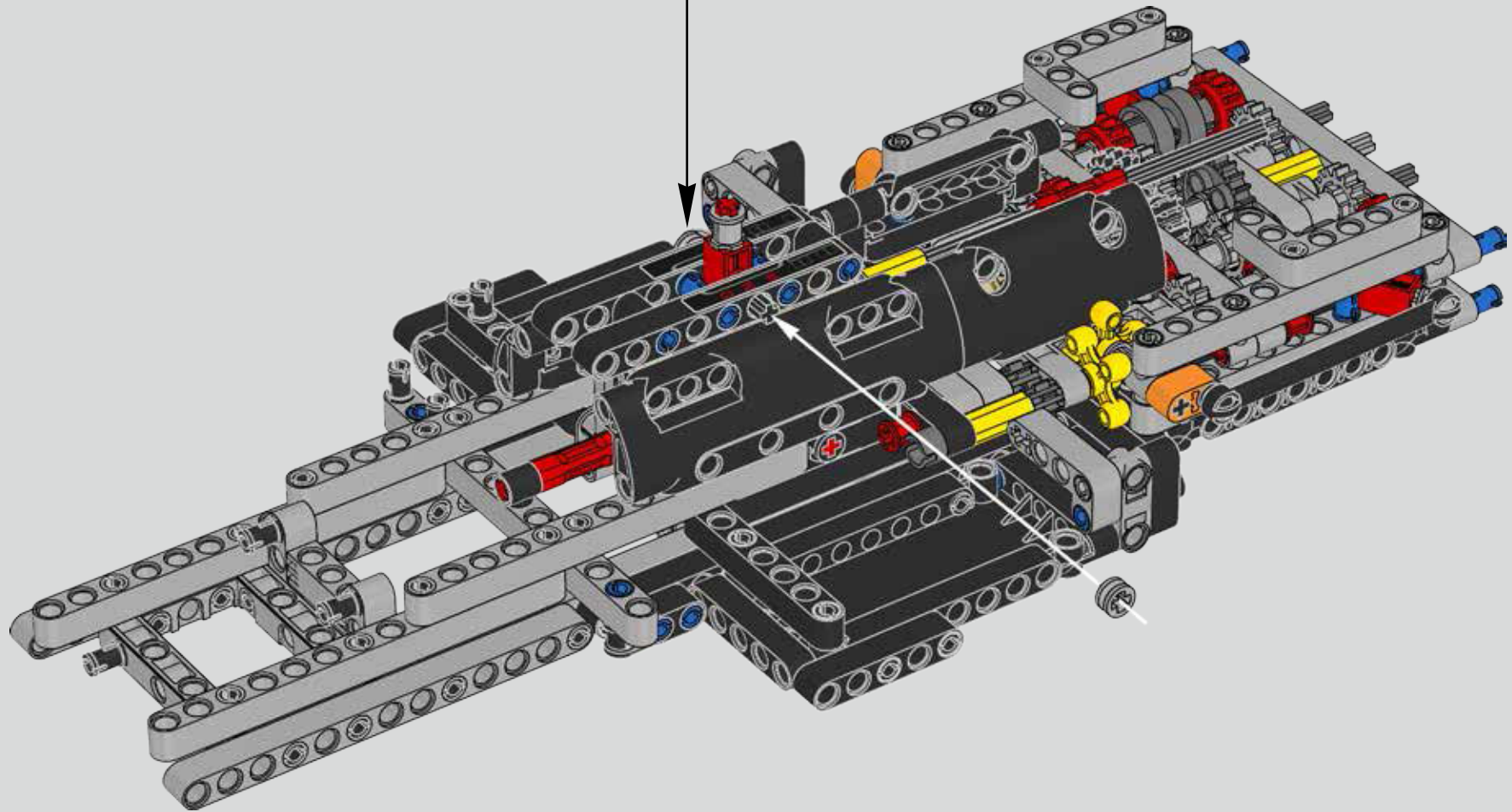
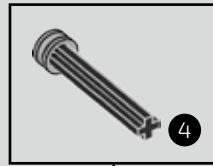

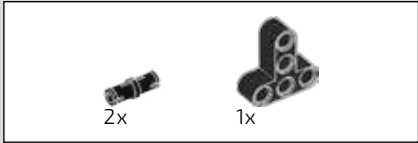

120

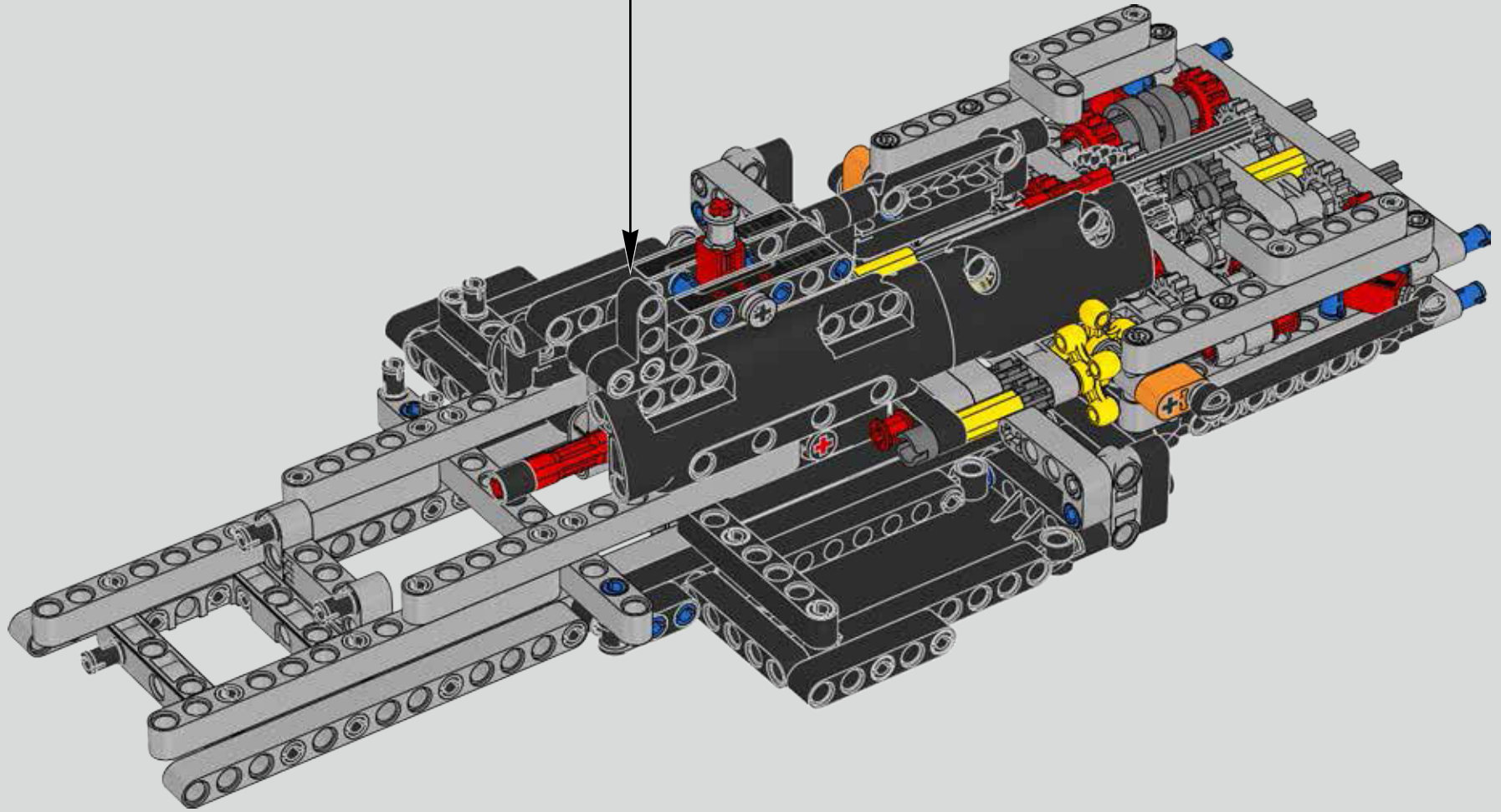
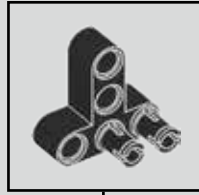

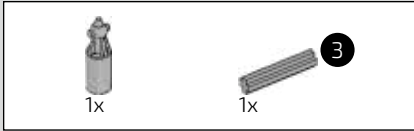

121

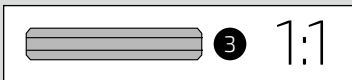
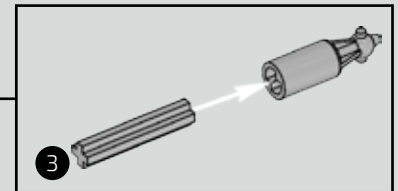
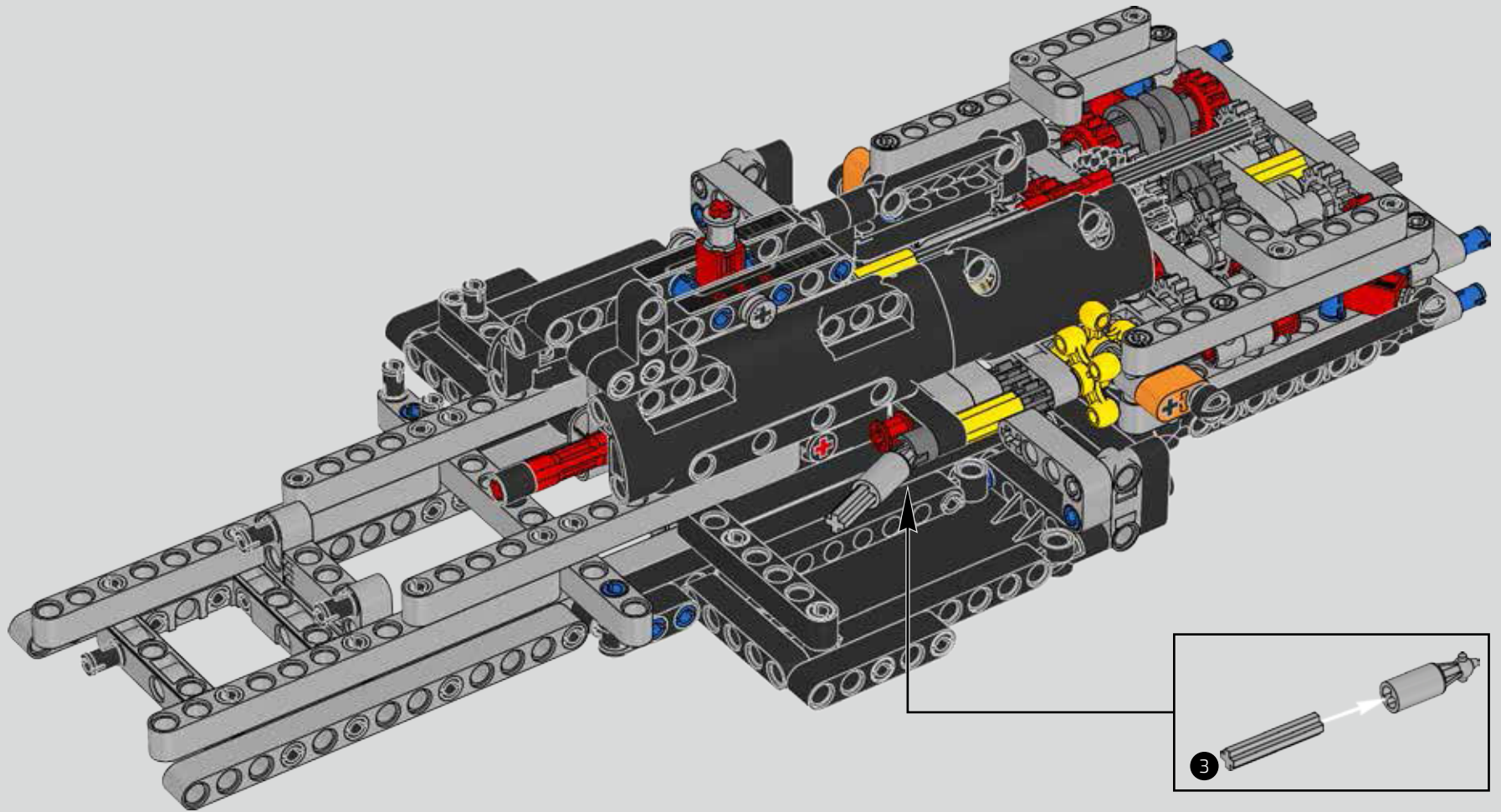

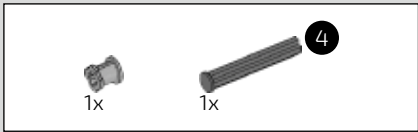
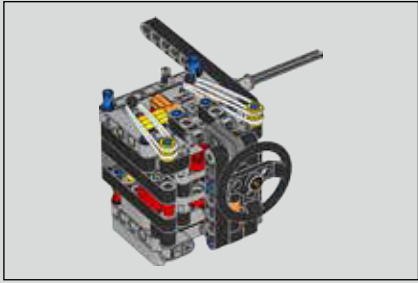

122

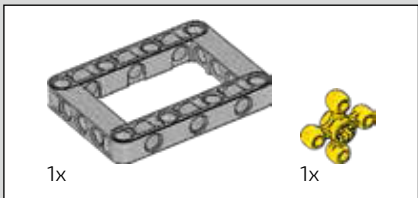
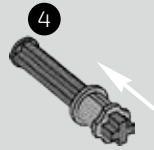

123

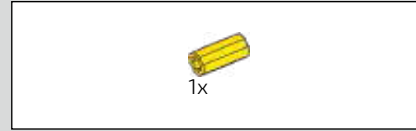
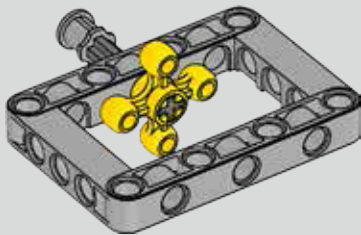

124

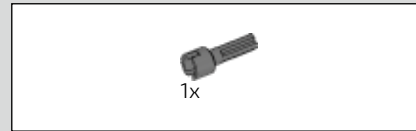
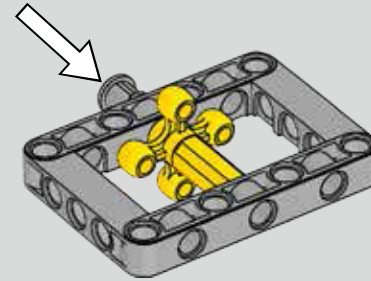

125

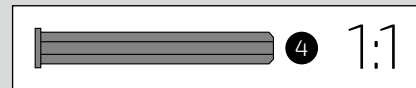
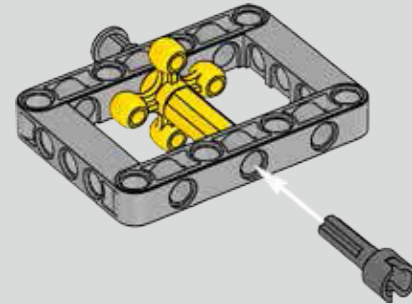

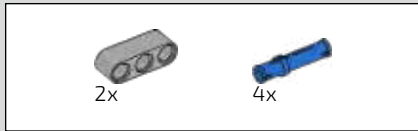

126

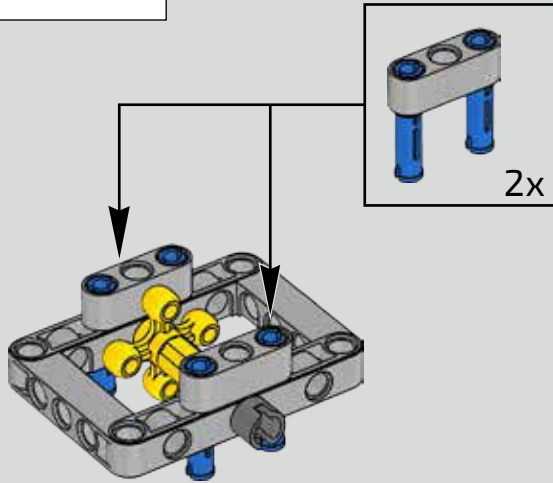

127

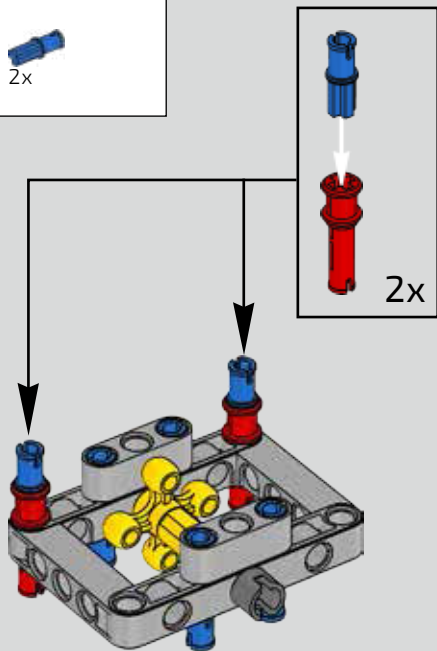

128

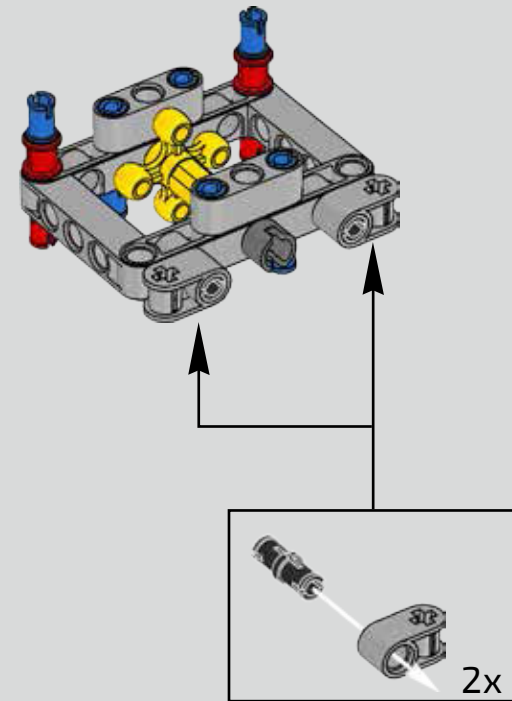

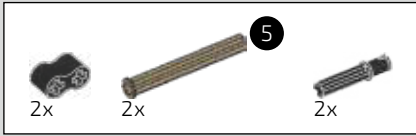

129

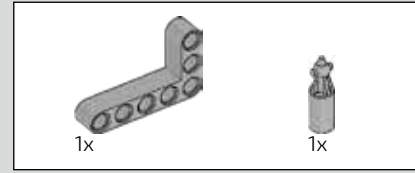
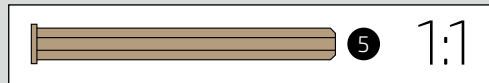
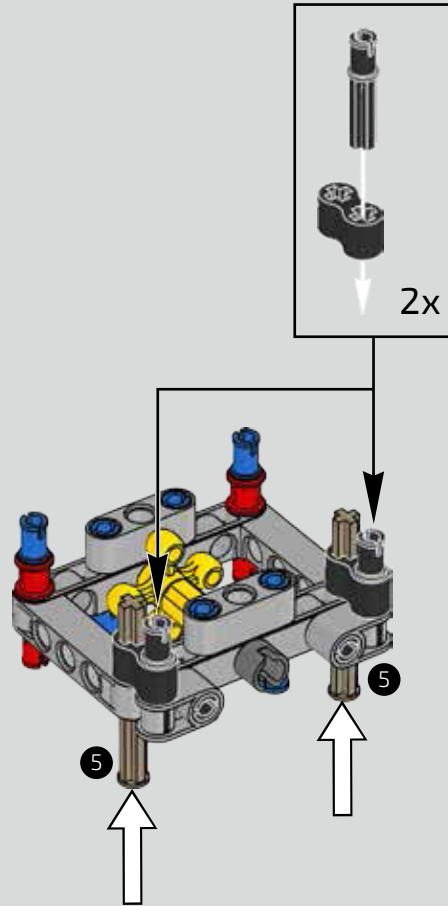

130

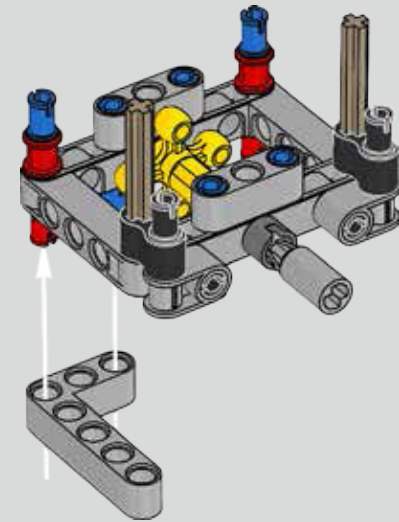

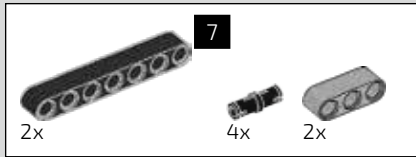

131

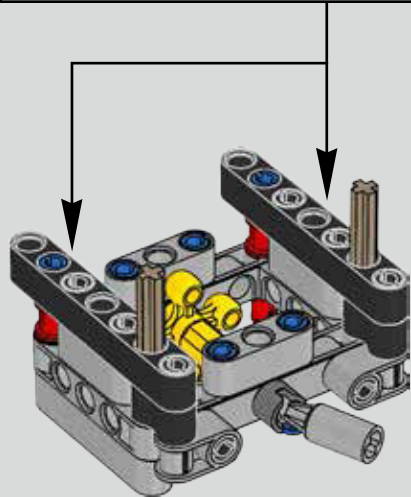
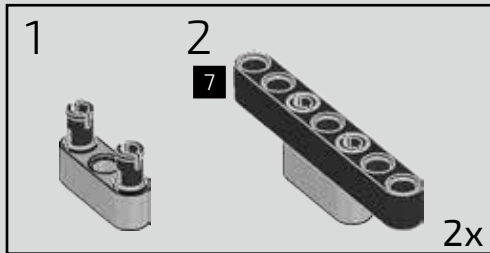

132

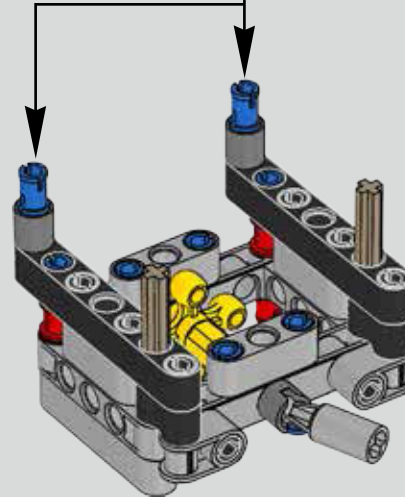
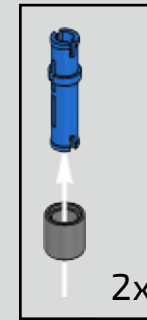

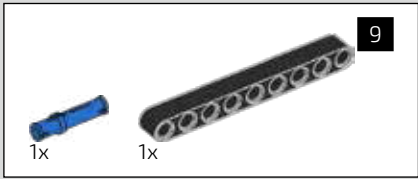
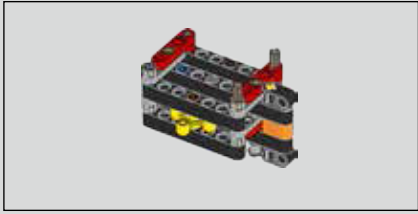

133

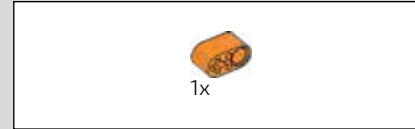
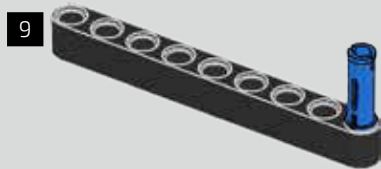

134

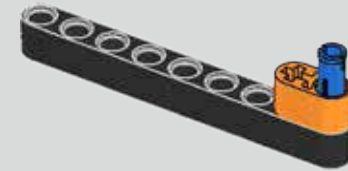

135

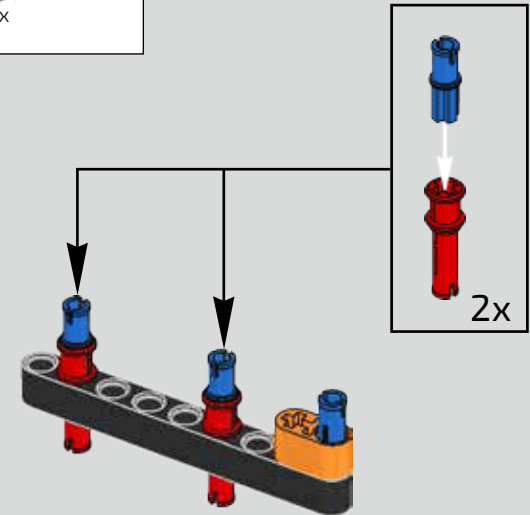

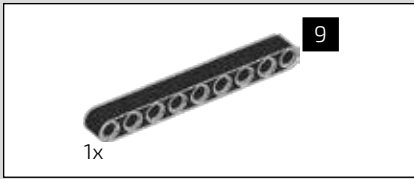

136

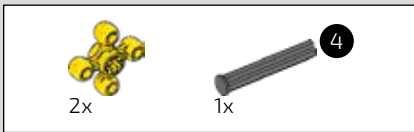
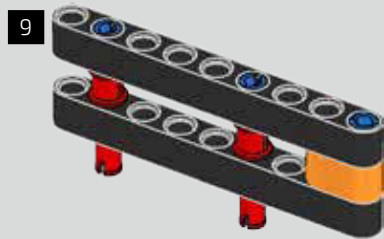

137

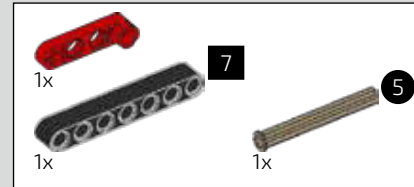
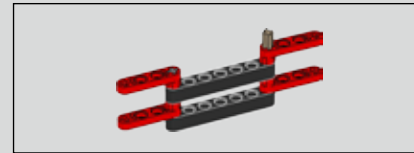
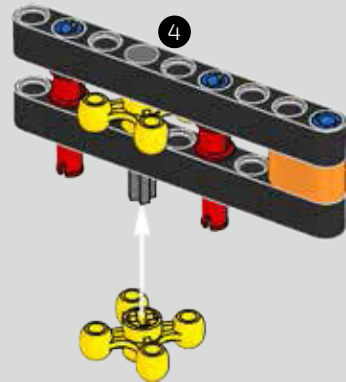

138

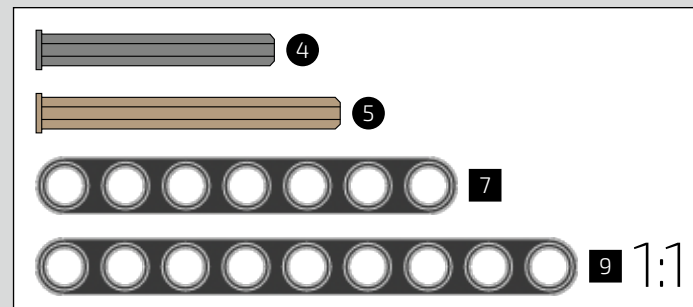
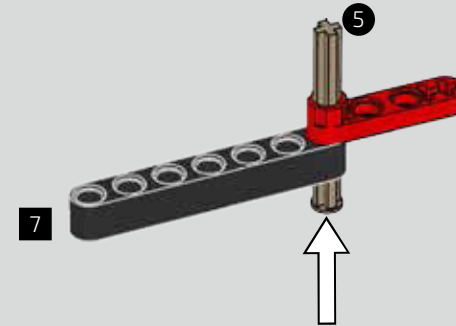

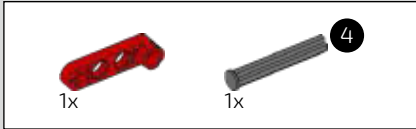

139

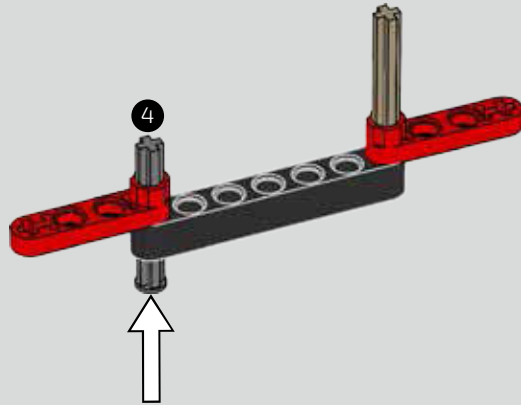

140

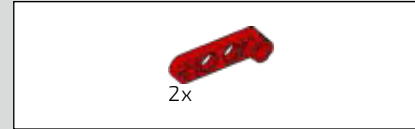
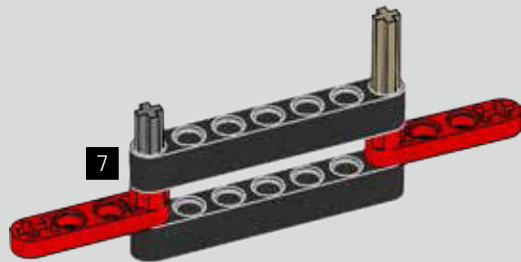

141

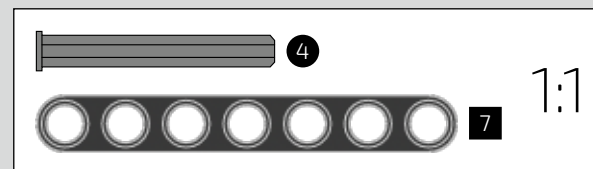
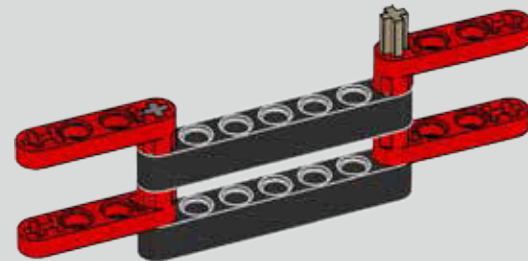

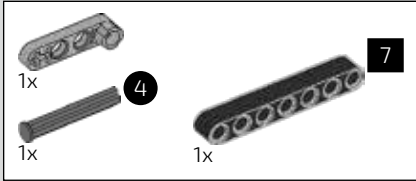
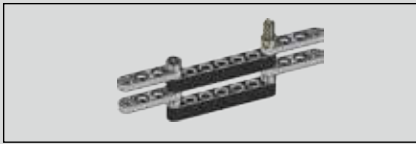

142

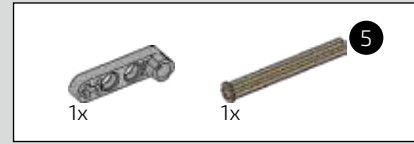
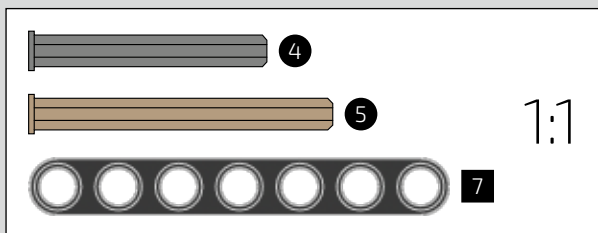
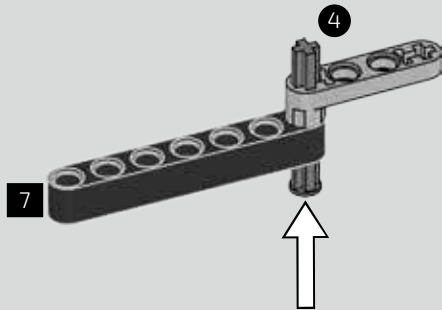

143

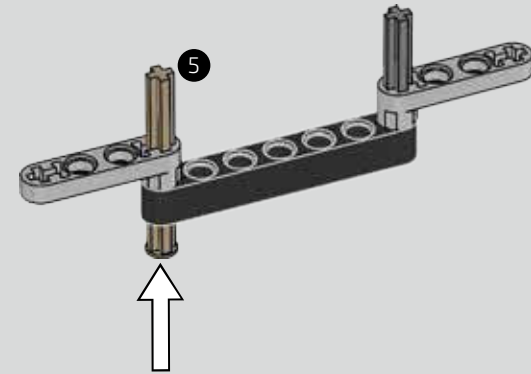

144

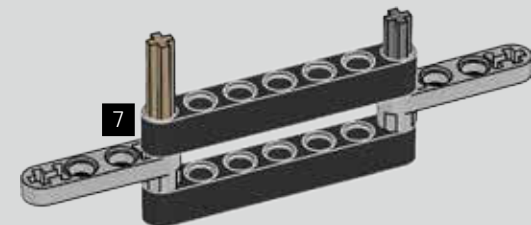

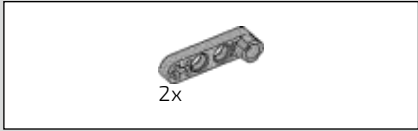

145

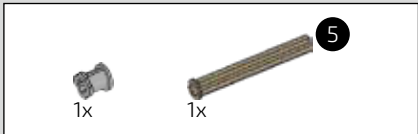
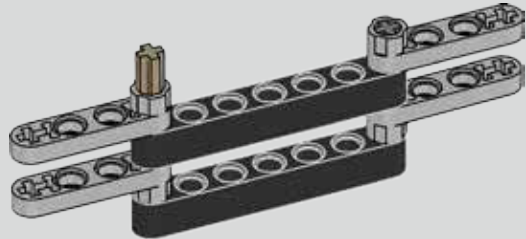

146

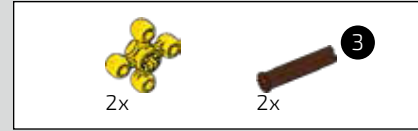
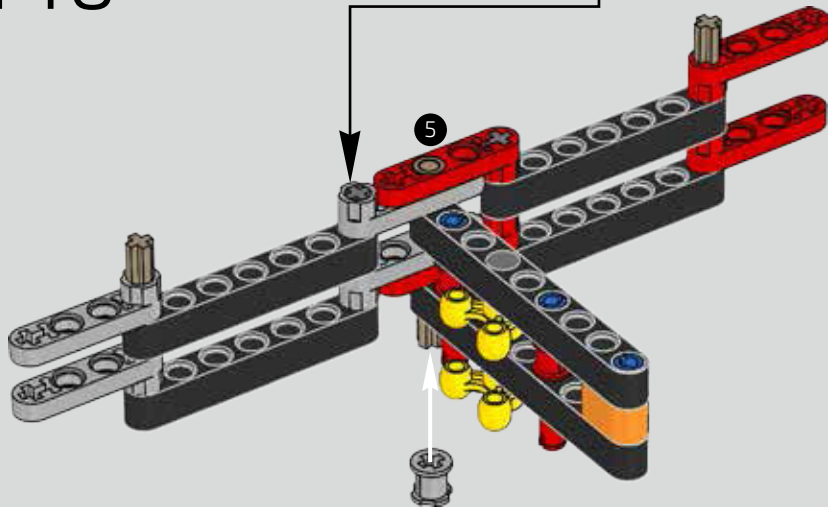

147

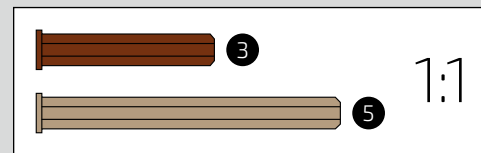
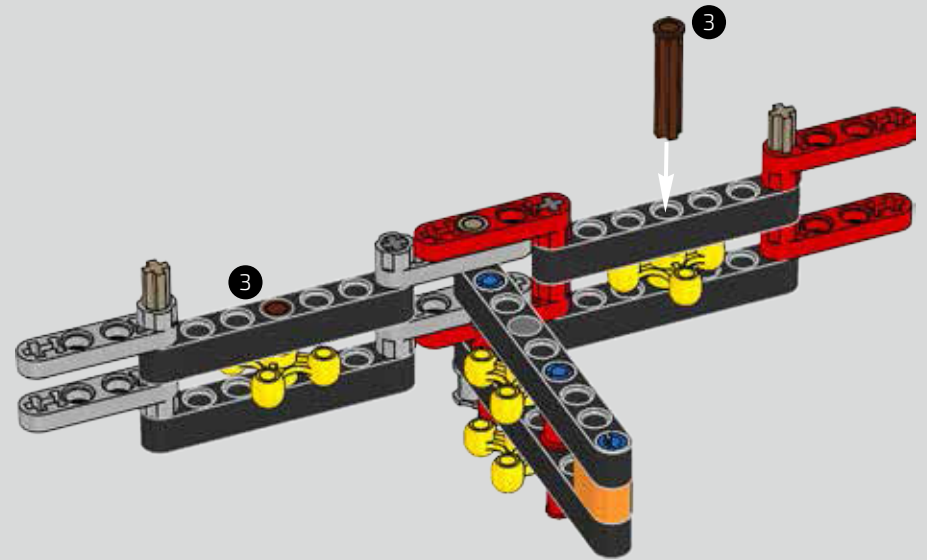

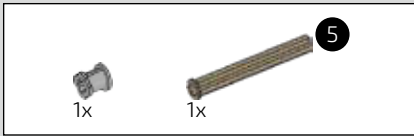

148

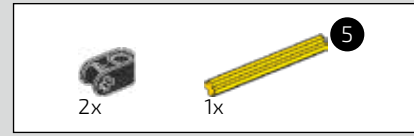
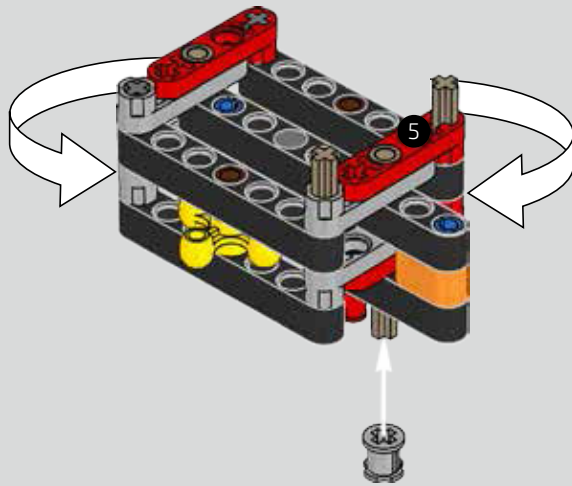

149

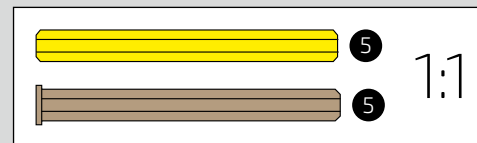
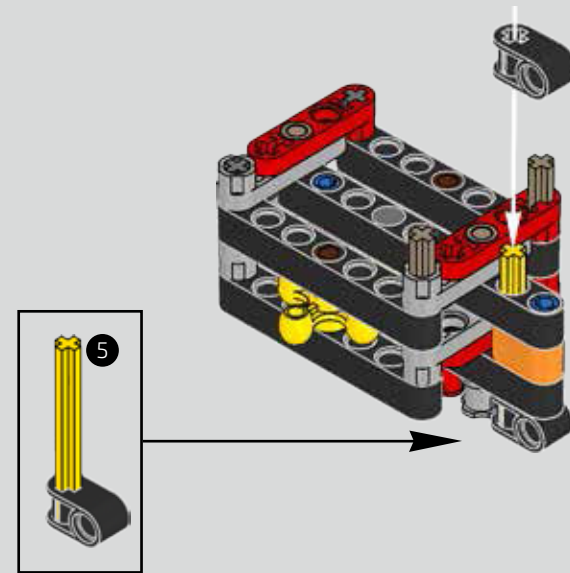

150

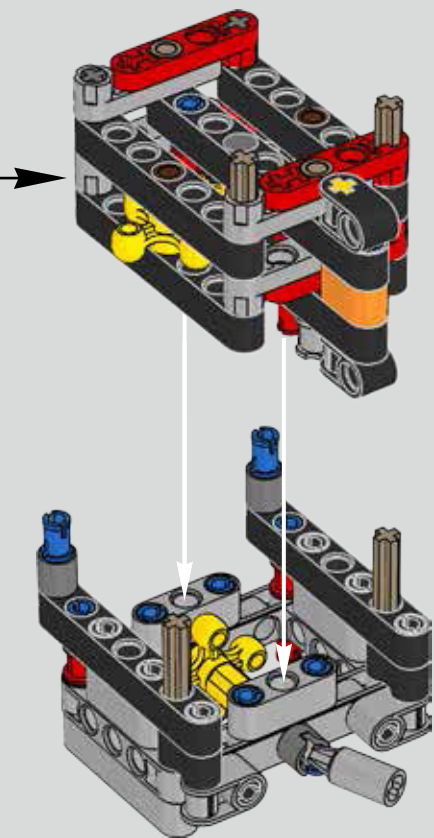

151

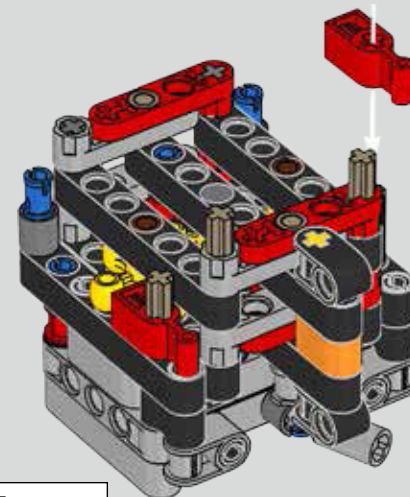

152

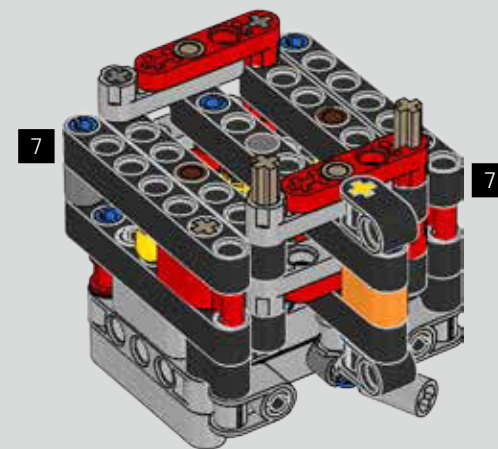

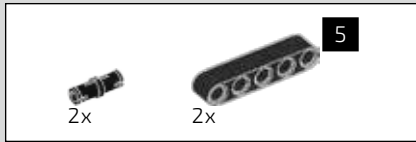

153

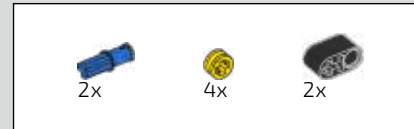
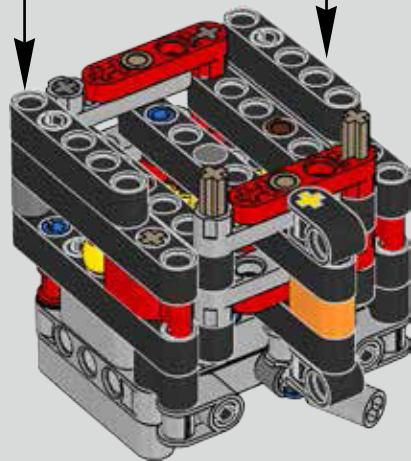

154

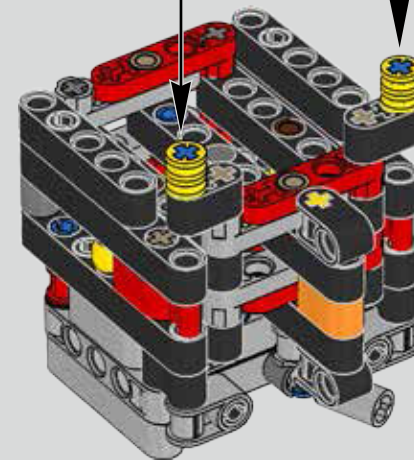
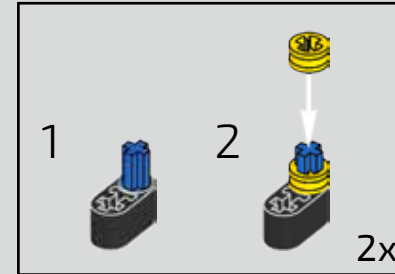

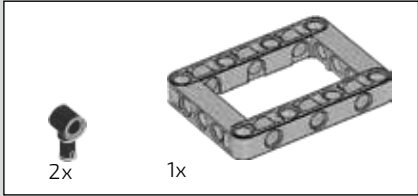
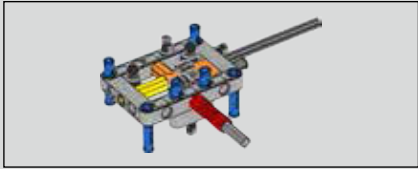

155

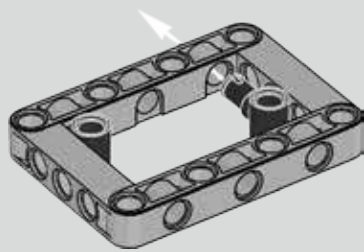

156

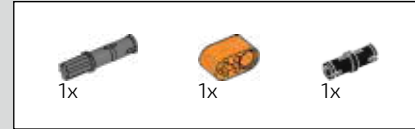
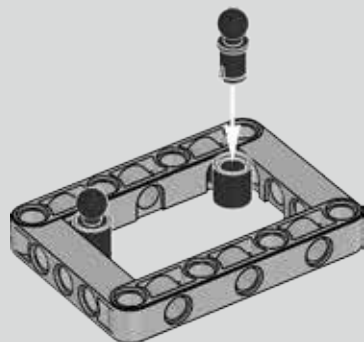

157

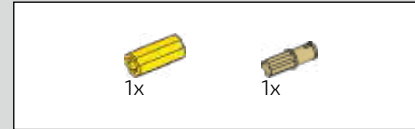
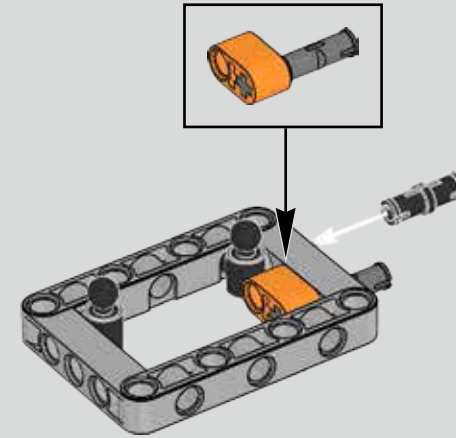

158

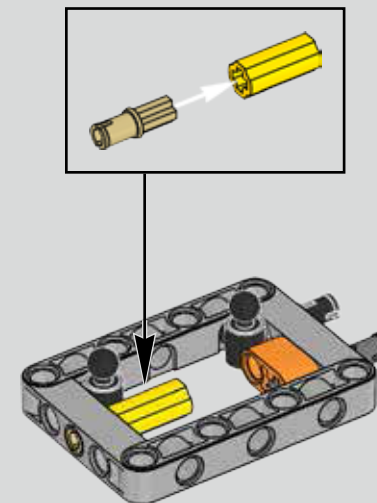

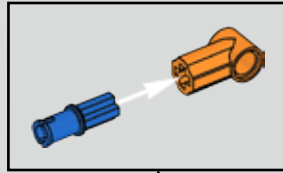

159

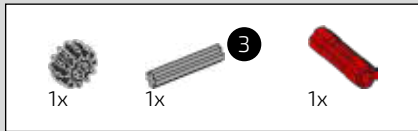
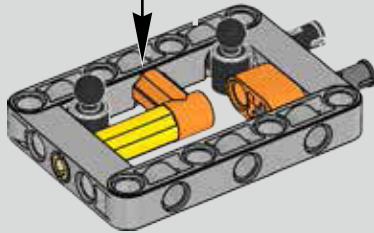

160

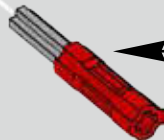
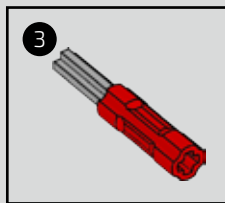
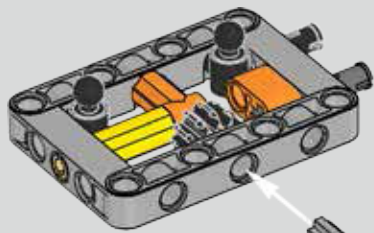

161

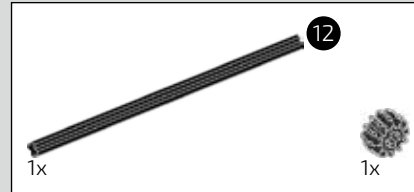
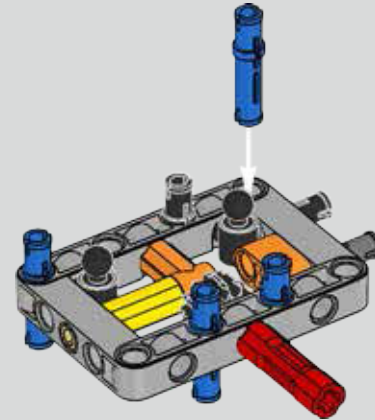

162

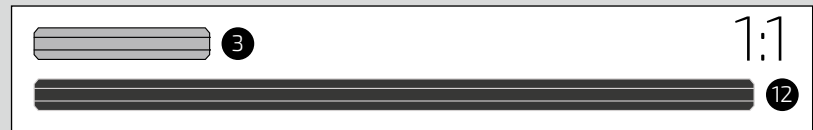
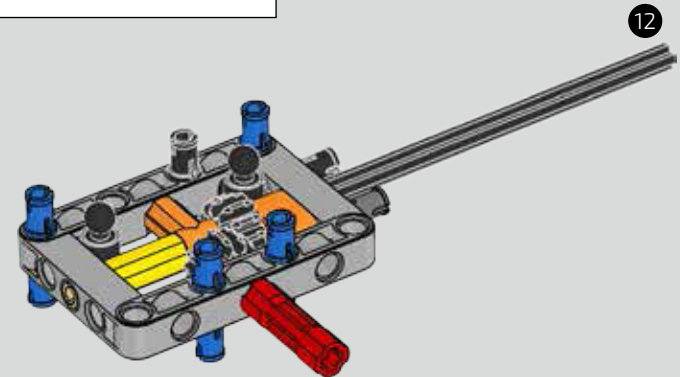

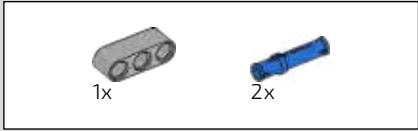

163

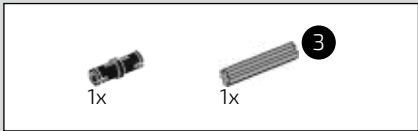
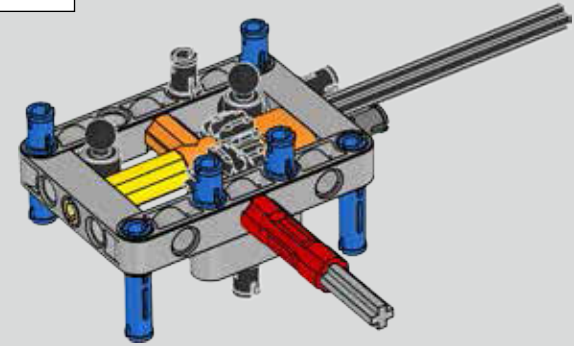
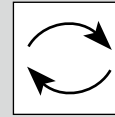
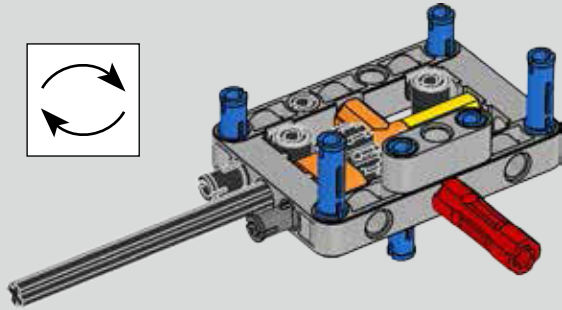
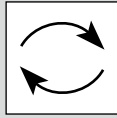

164

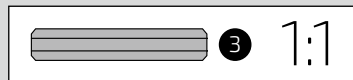
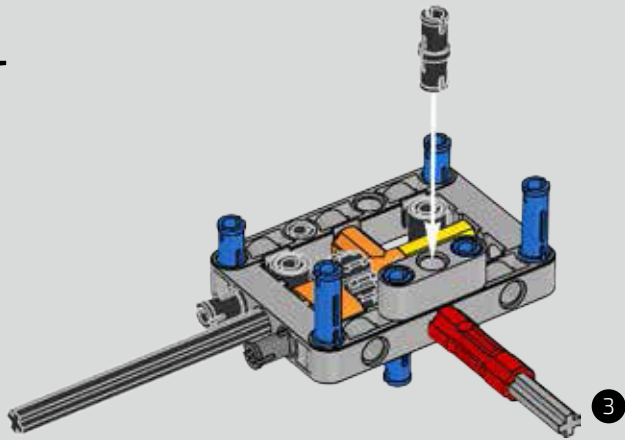

165

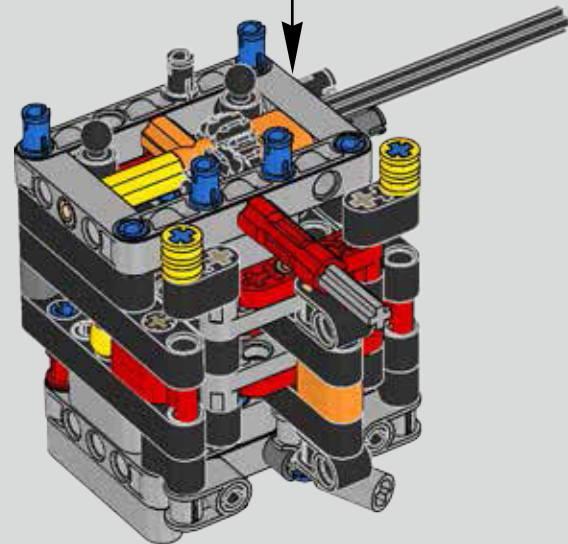



166

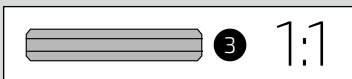
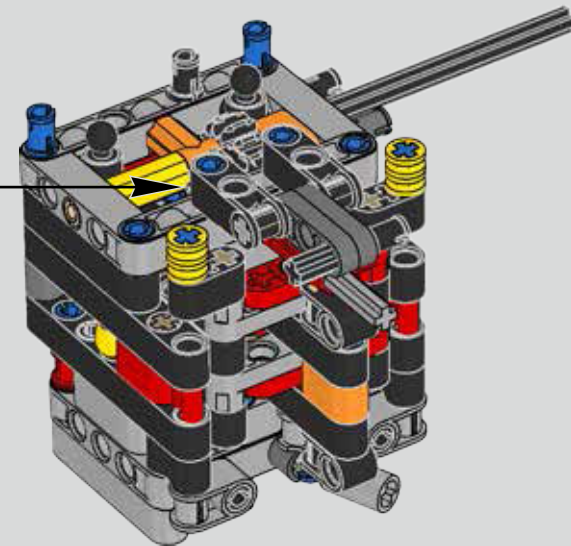
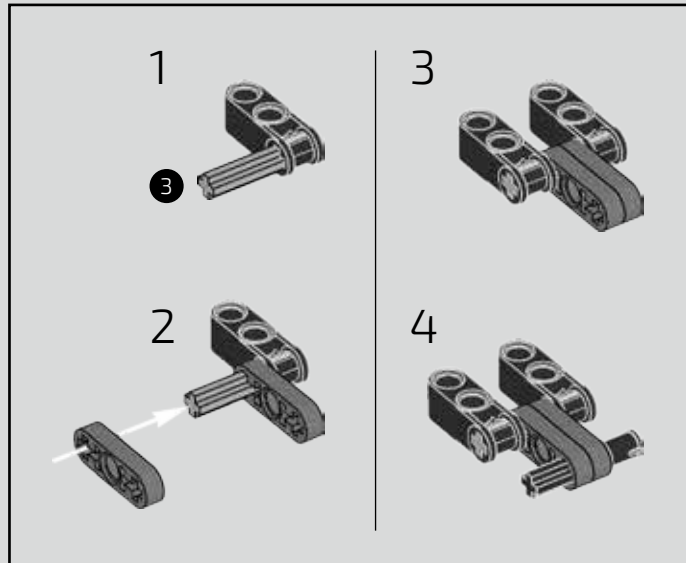

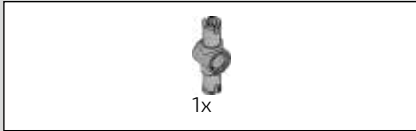

167

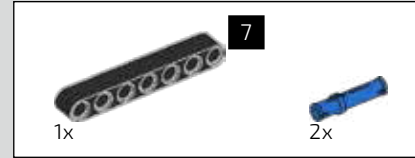
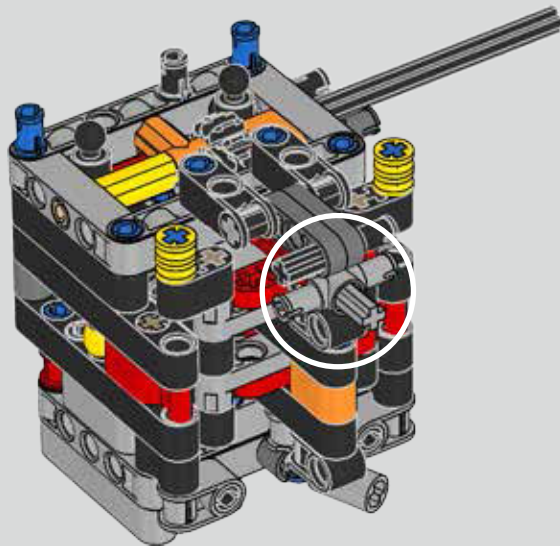

168

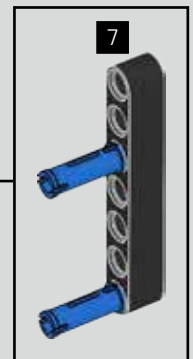
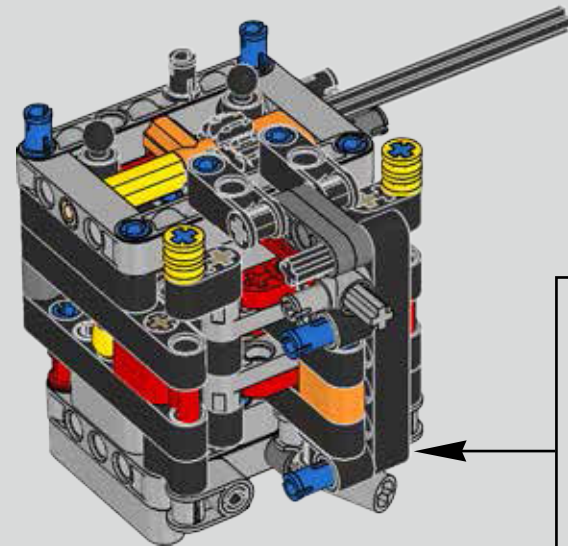



169

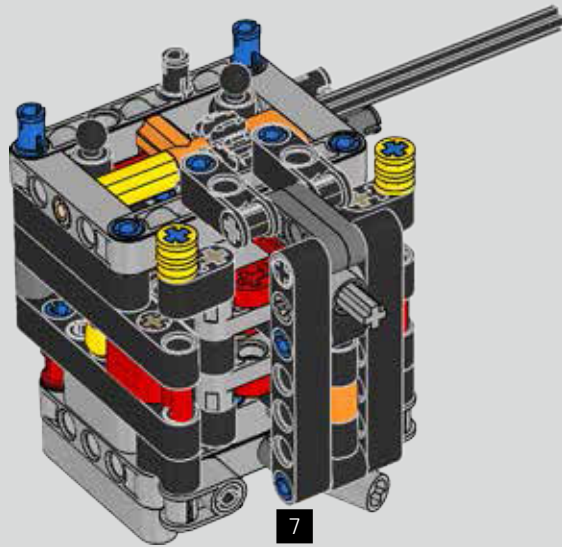

170

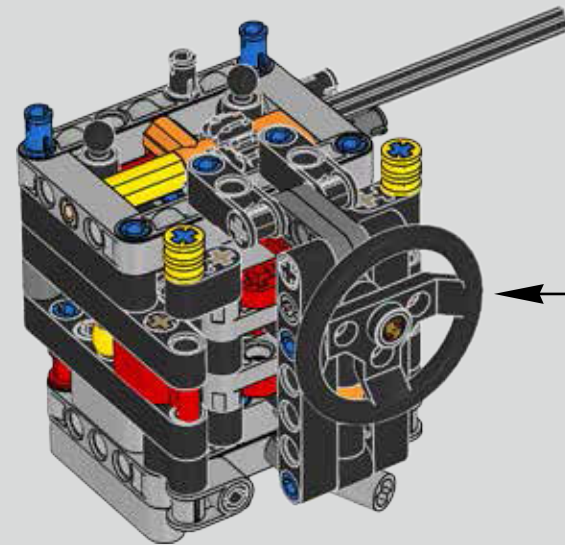
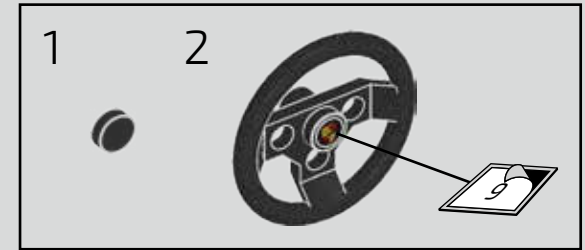

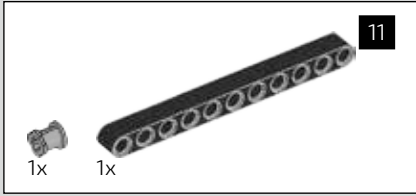

171

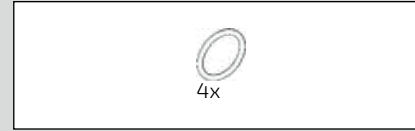
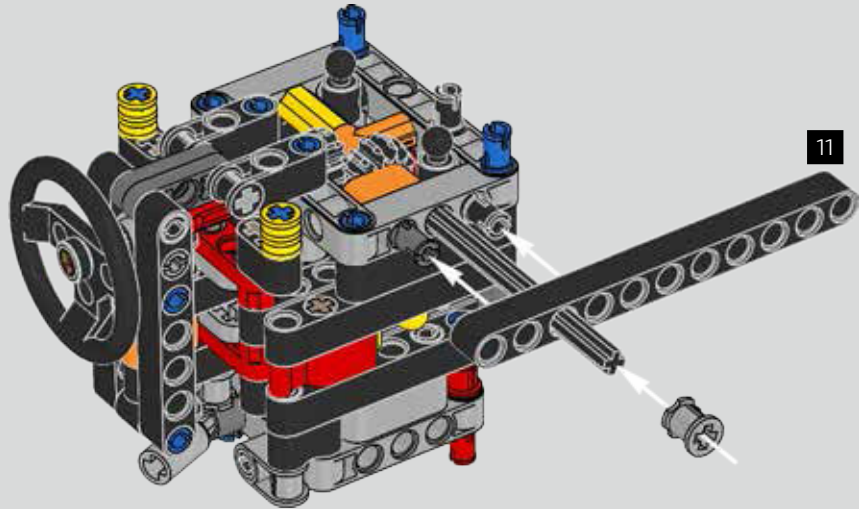
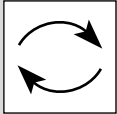

172

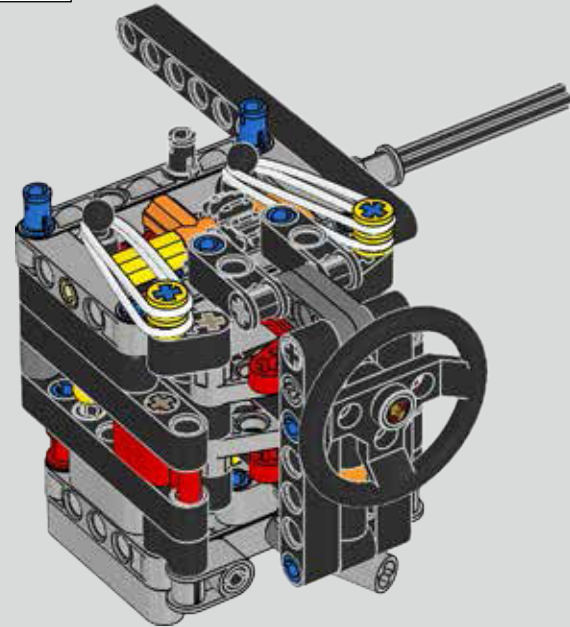
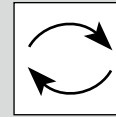

173

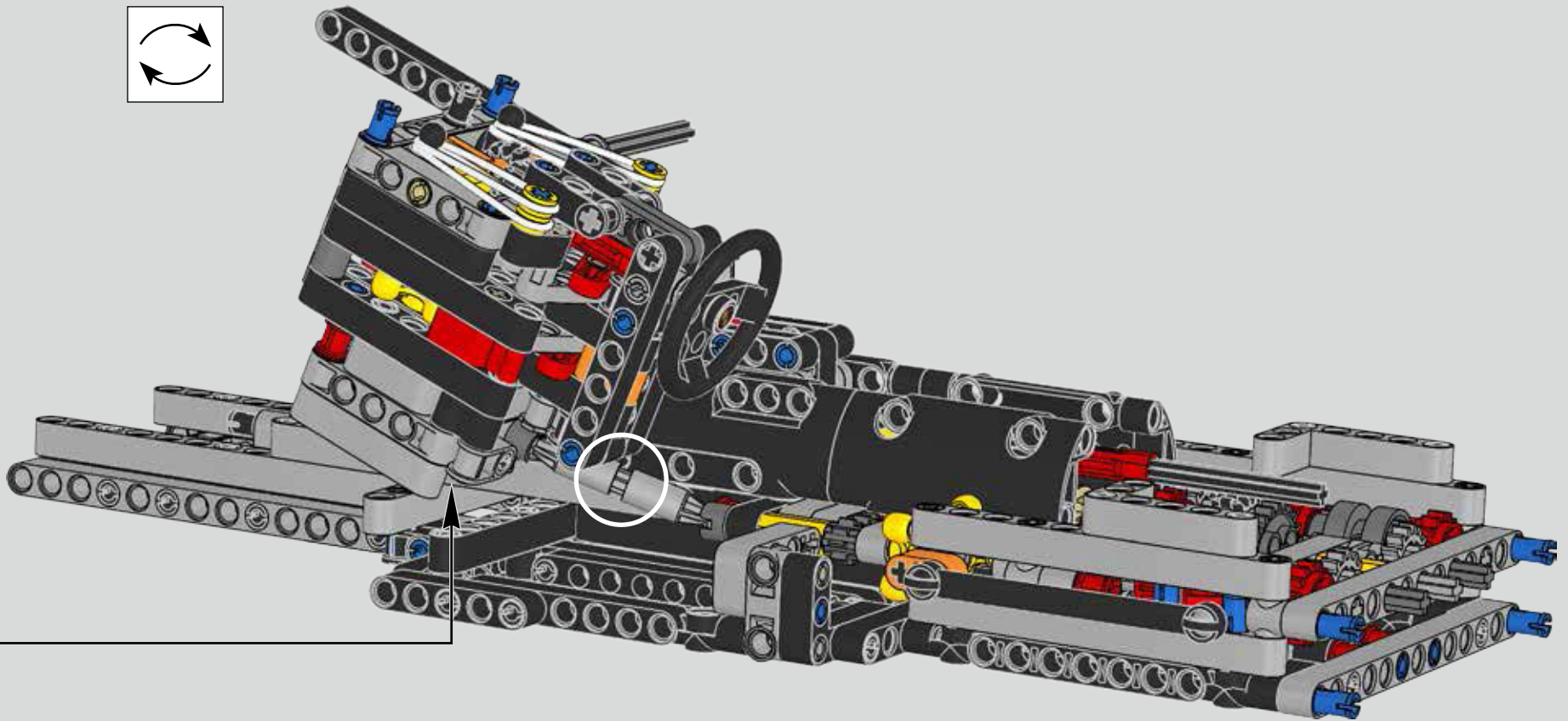
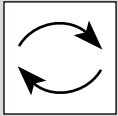

174

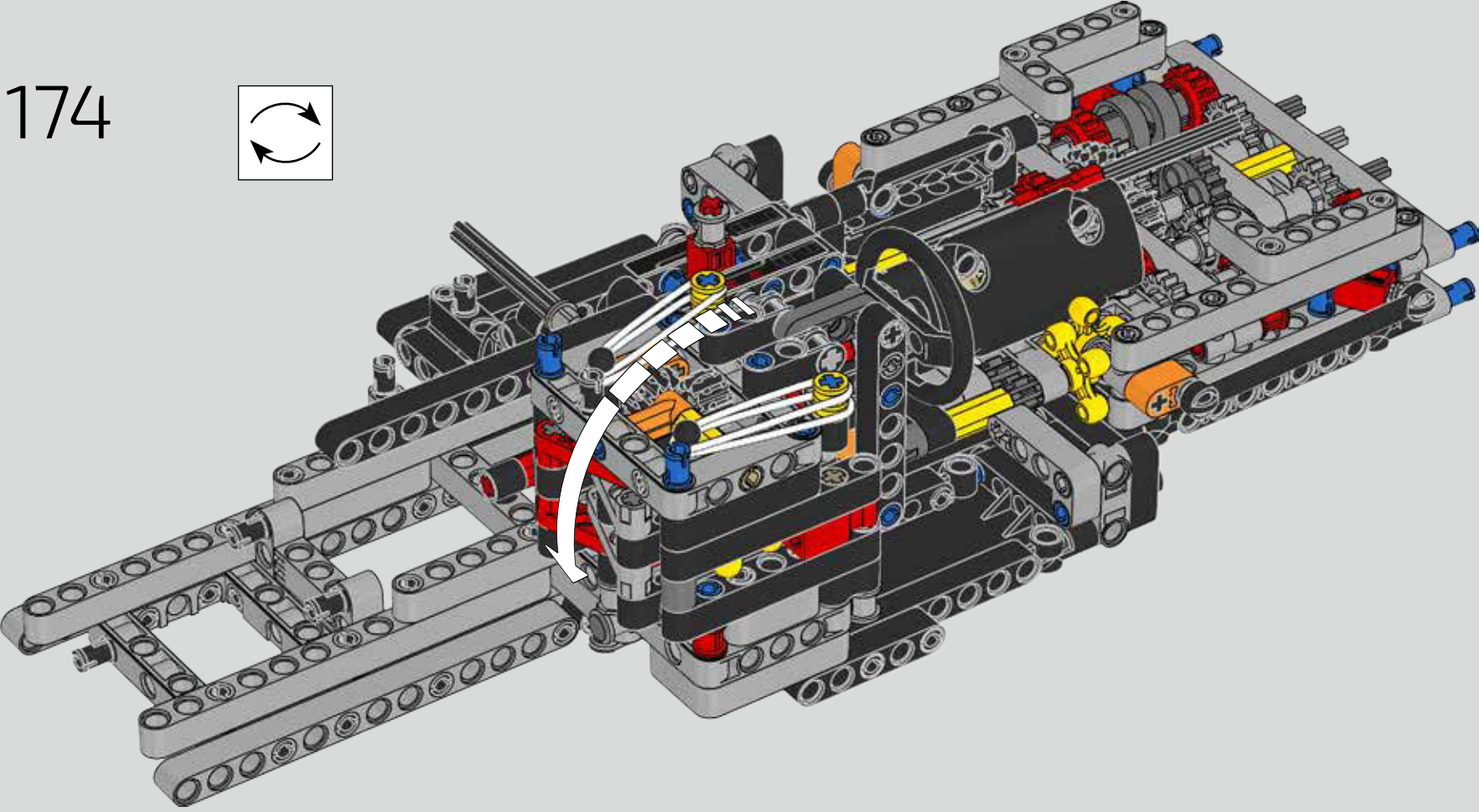
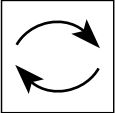

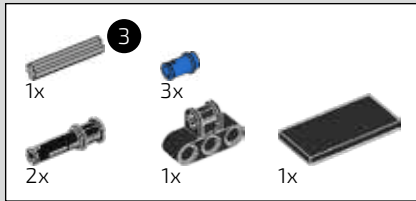

175

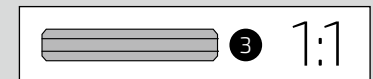
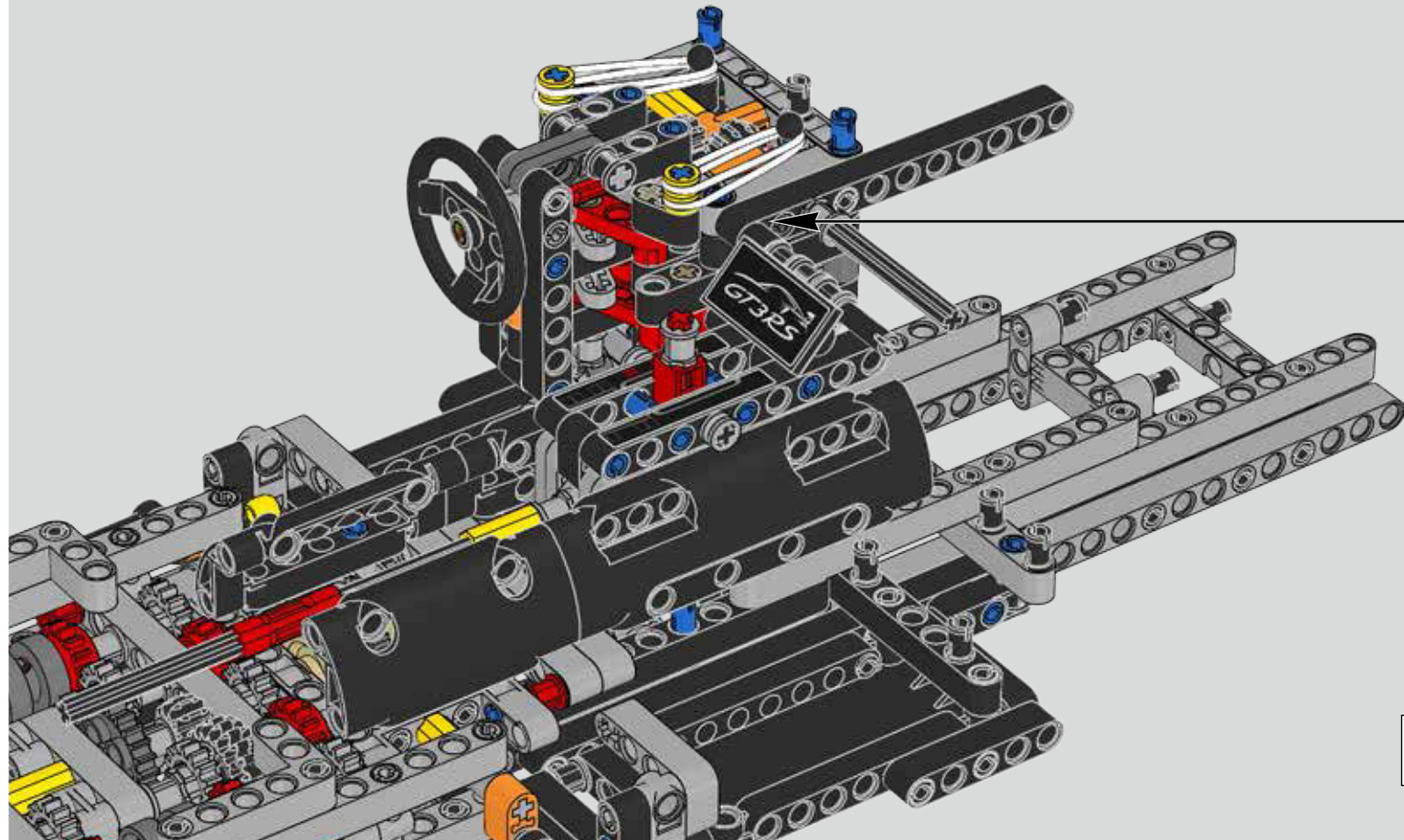
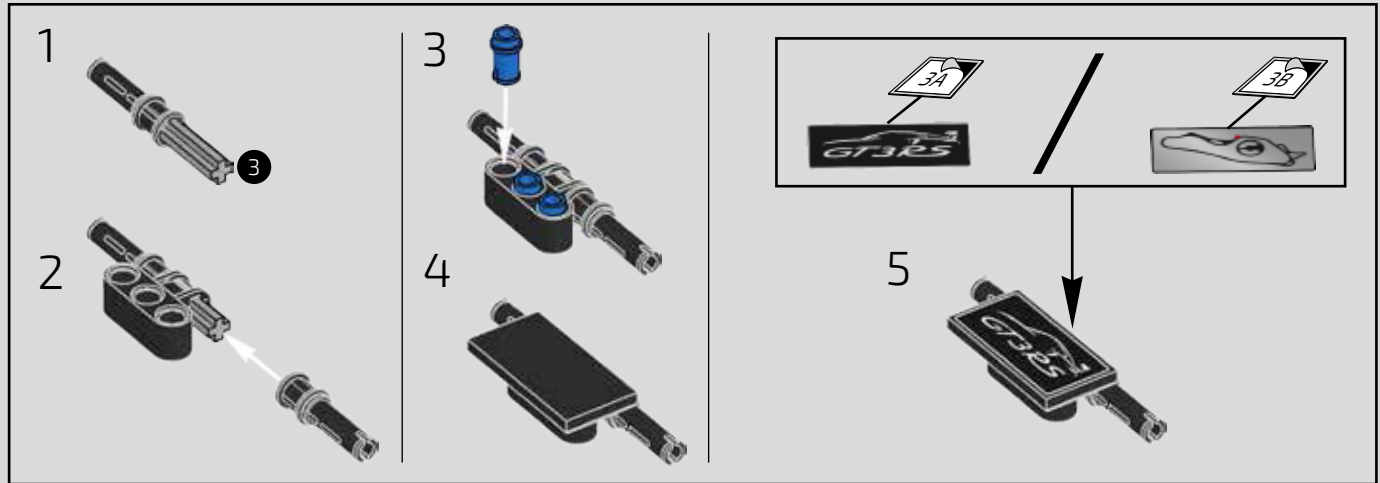
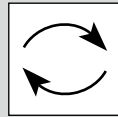

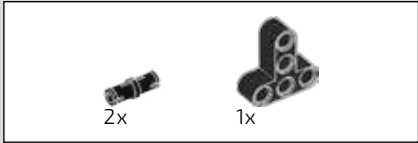

176

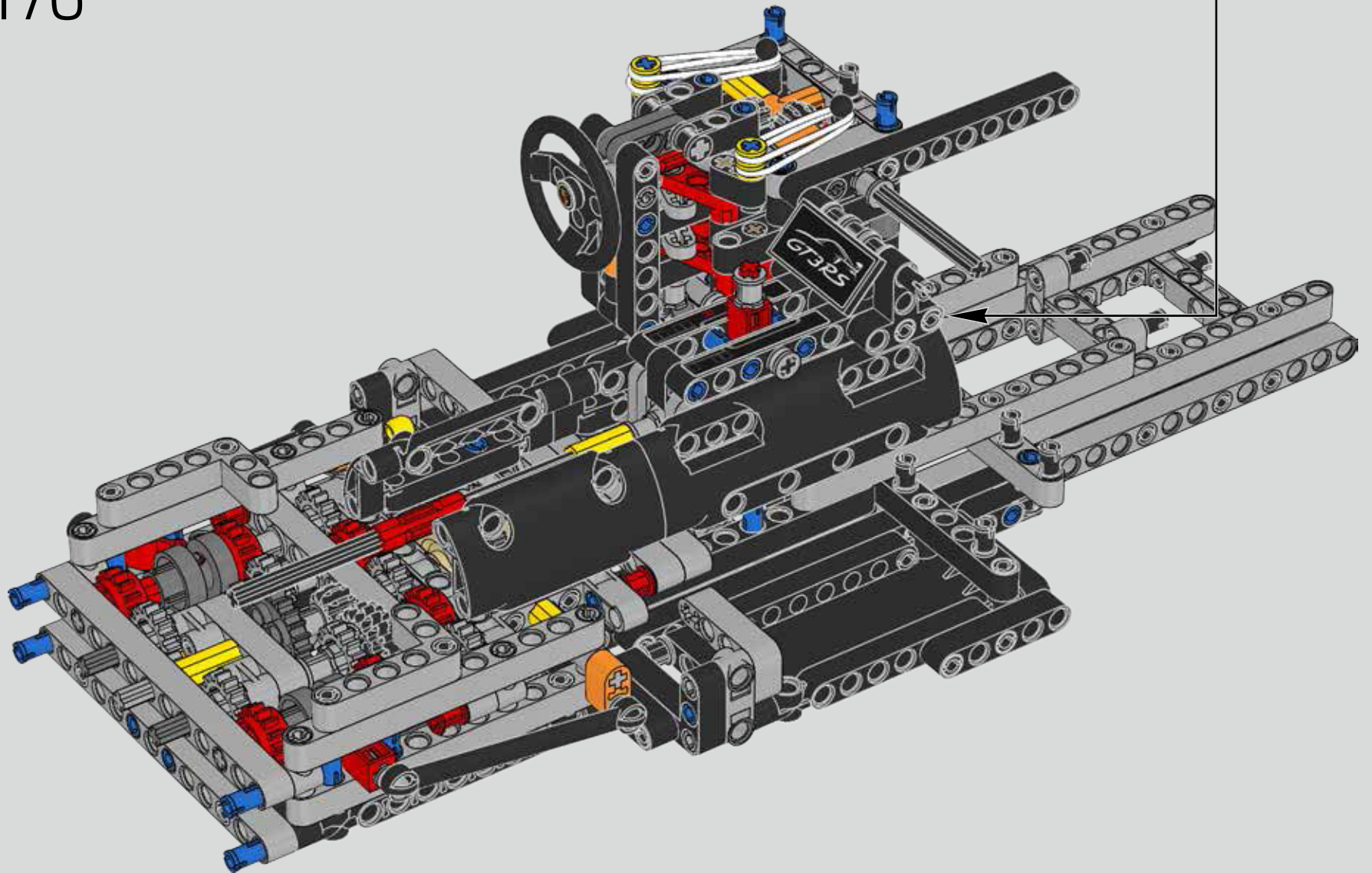
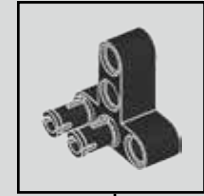

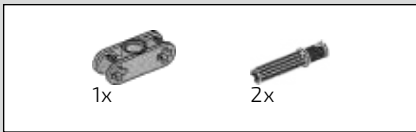
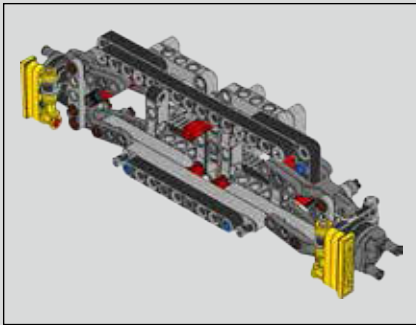

177

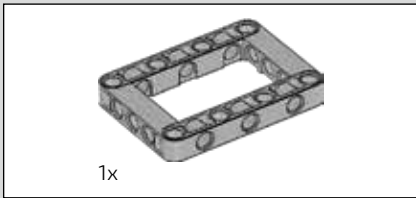

178

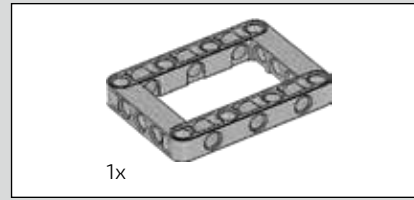
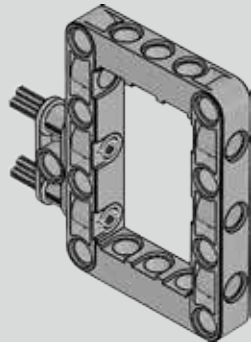
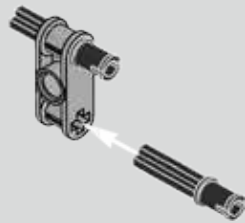

179

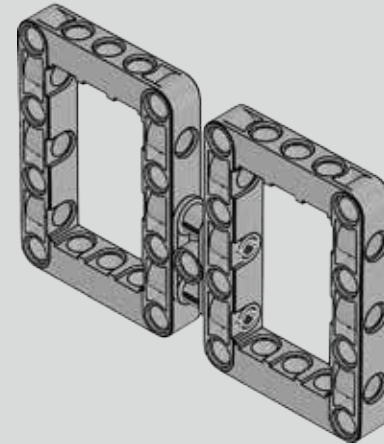

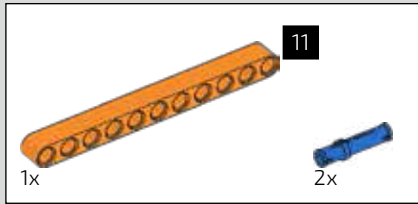

180

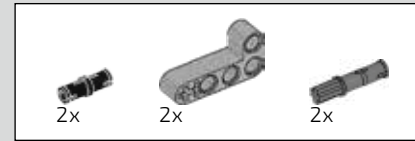
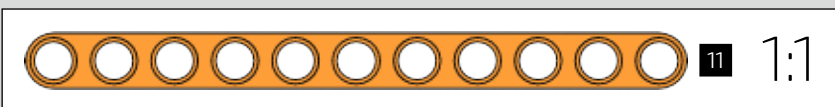
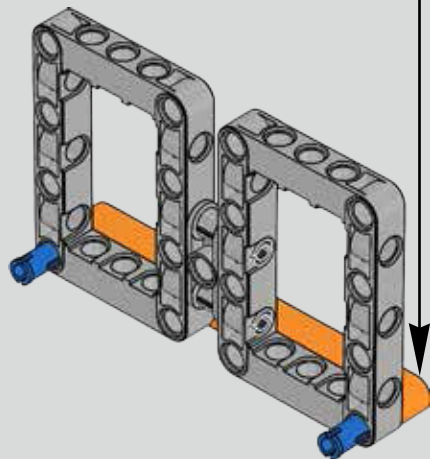
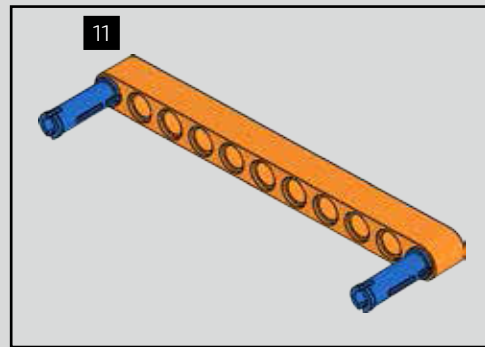

181

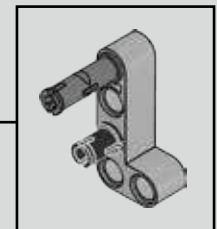
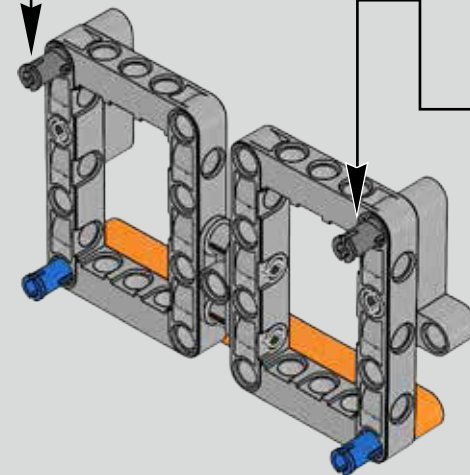
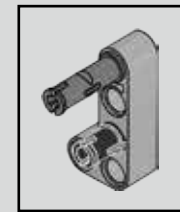

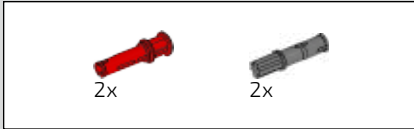

182

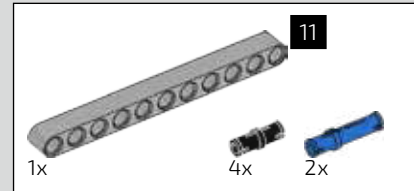
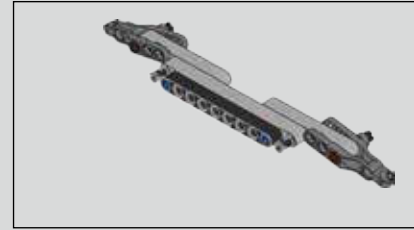
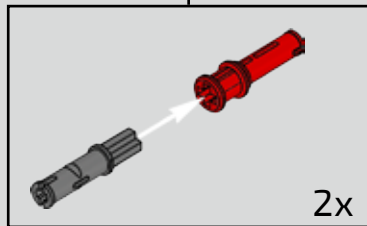
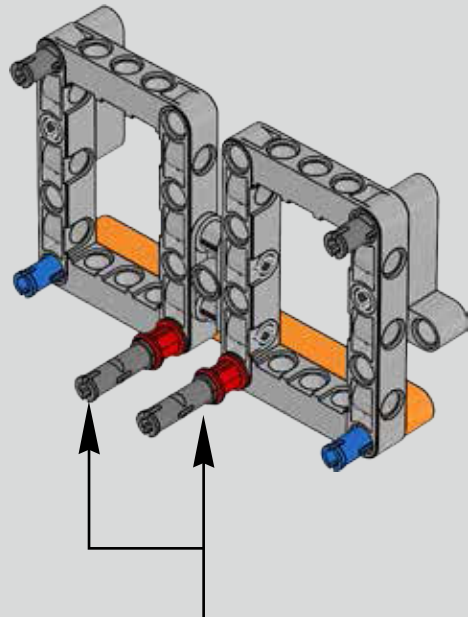

183

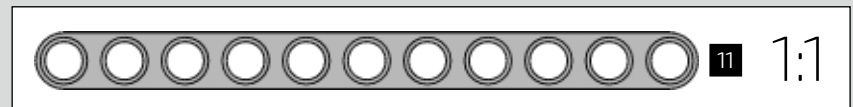
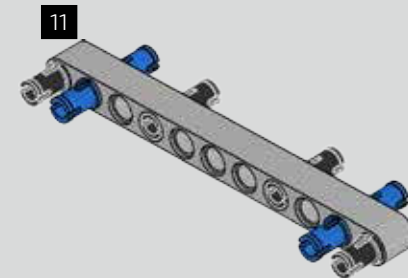

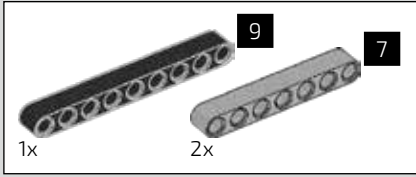

184

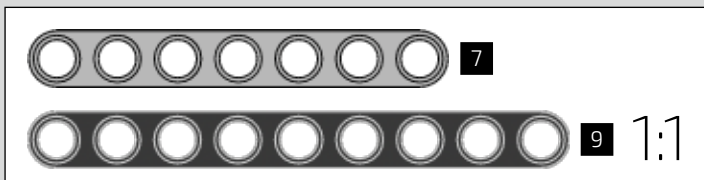
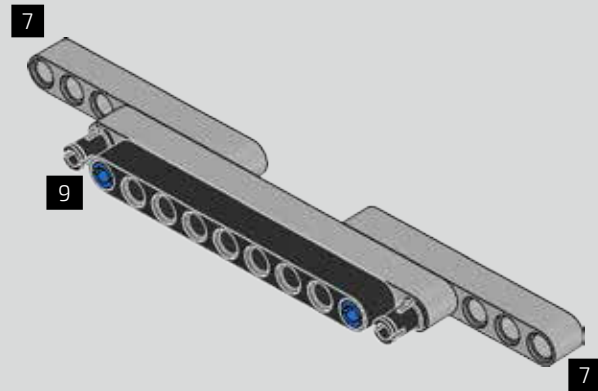

185

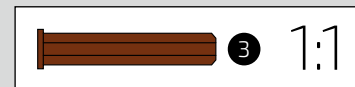
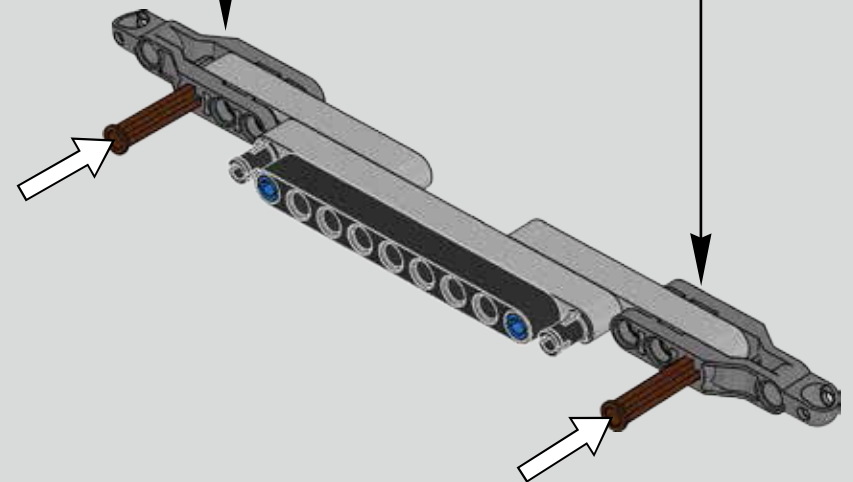
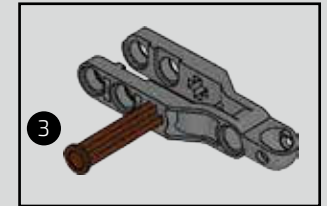
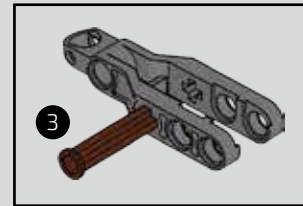
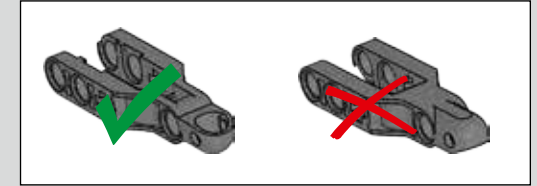



186

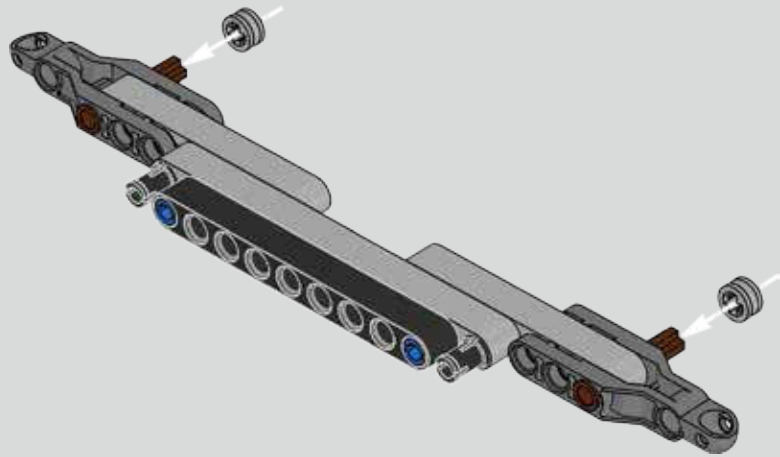

187

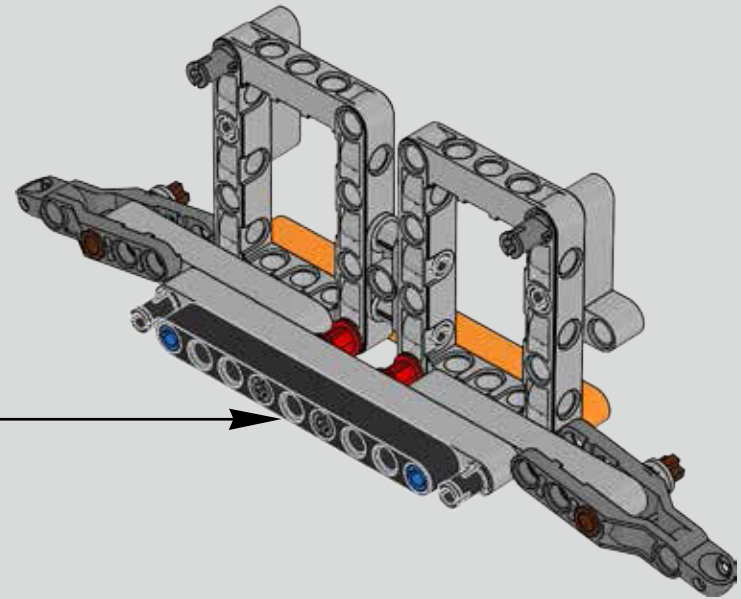

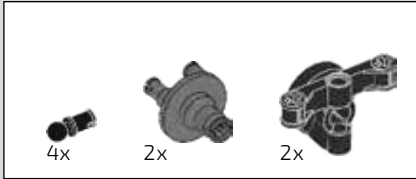

188

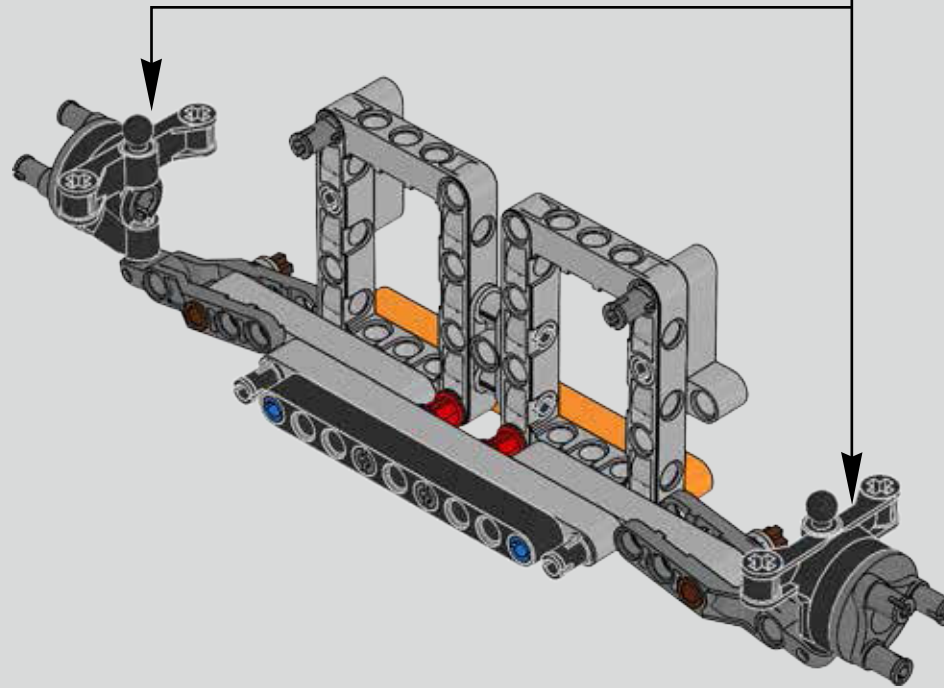
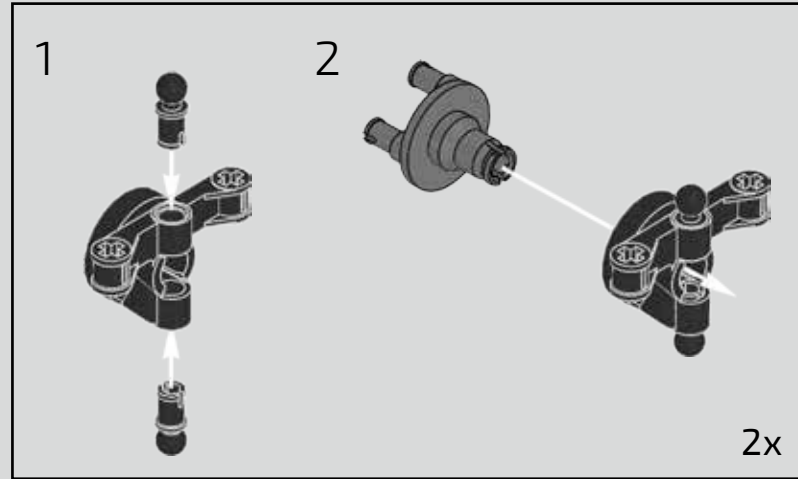
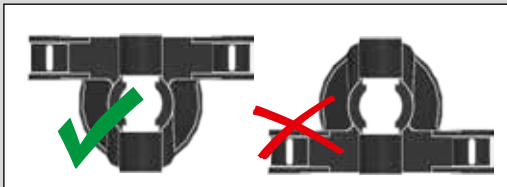

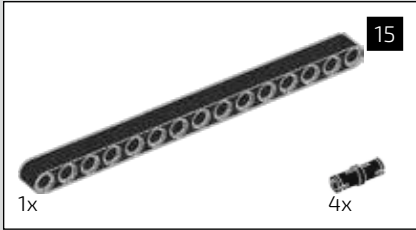
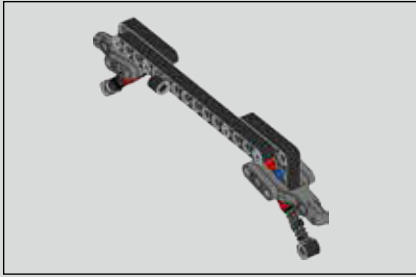

189

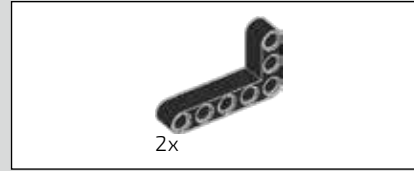
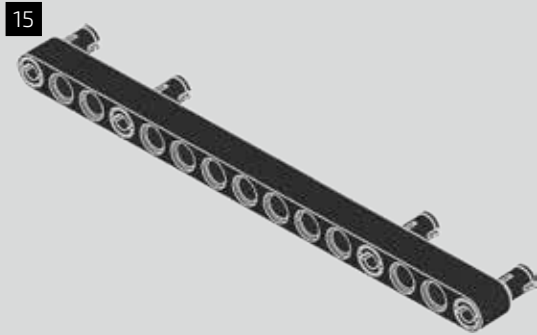

190

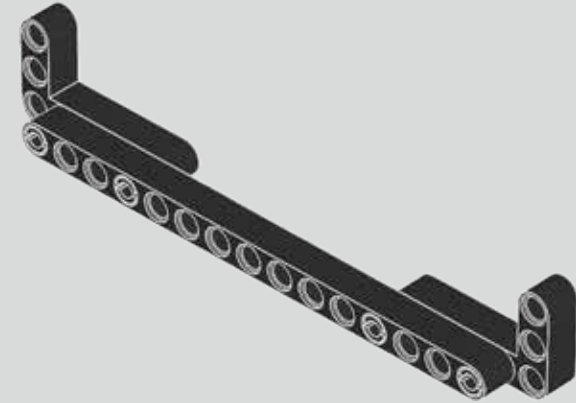

191

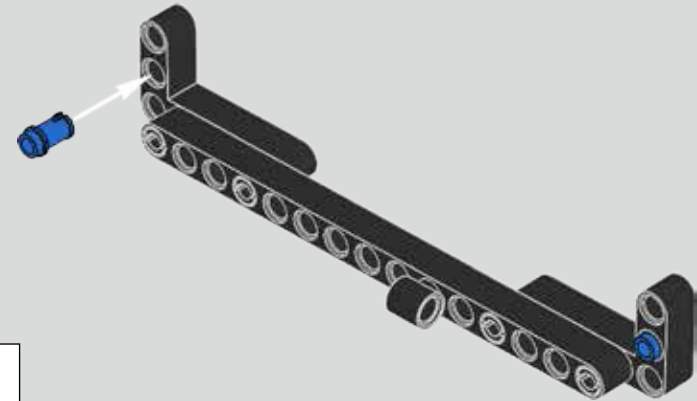

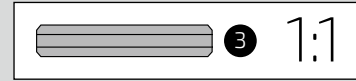
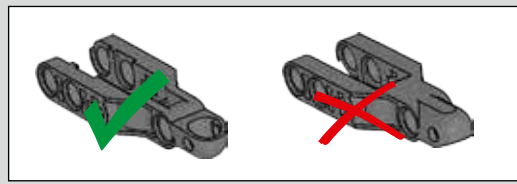
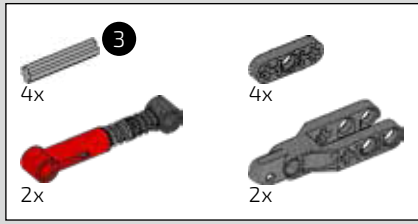

192

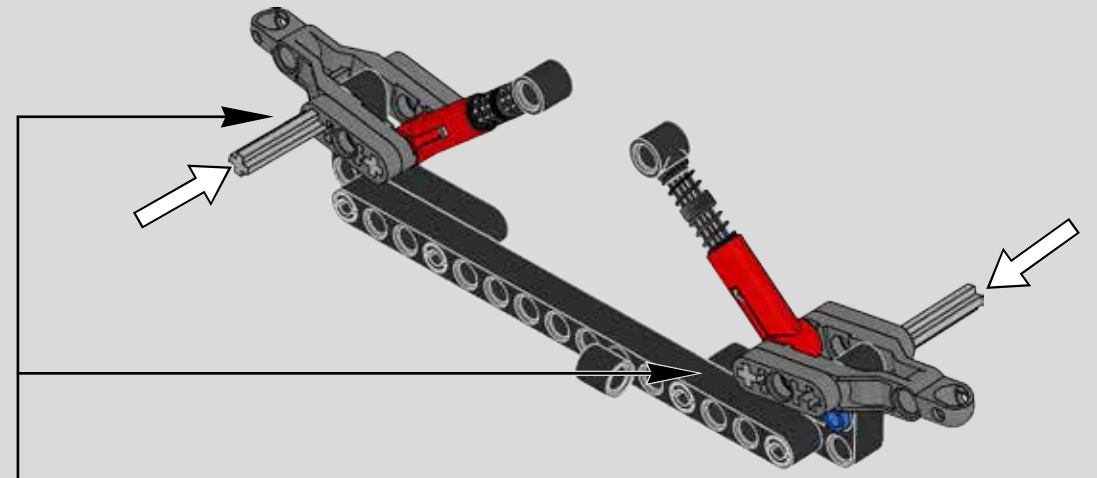
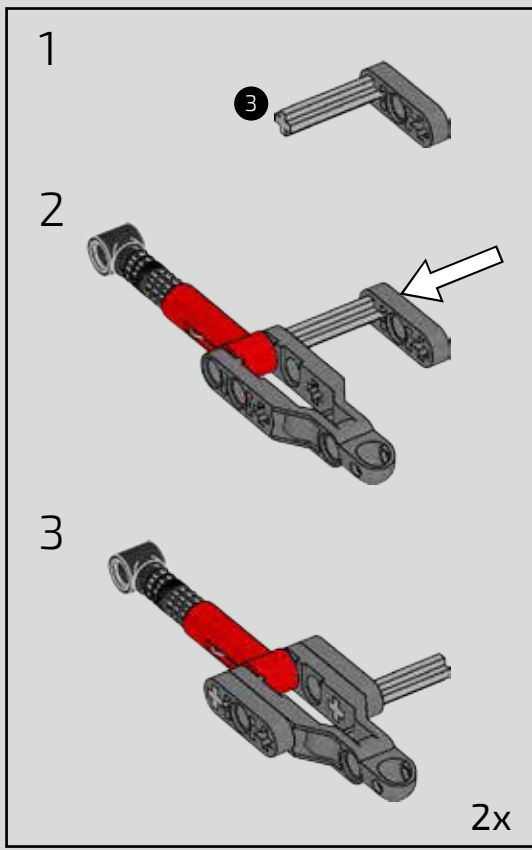

193

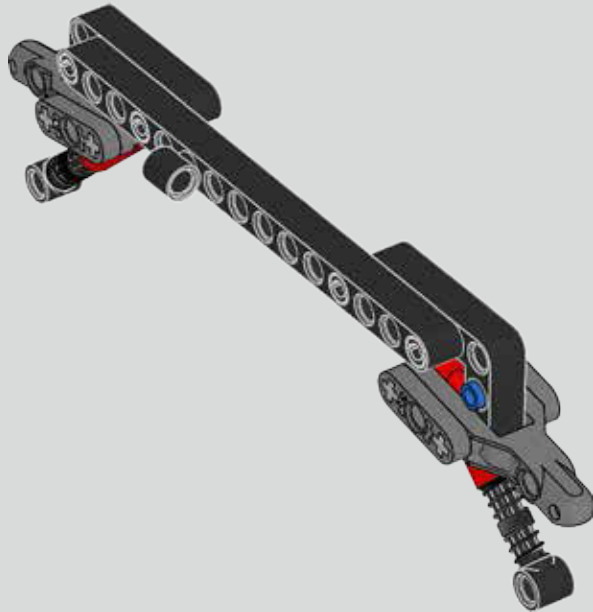
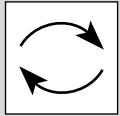

194

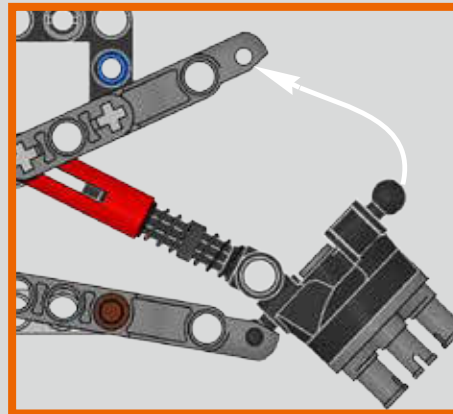
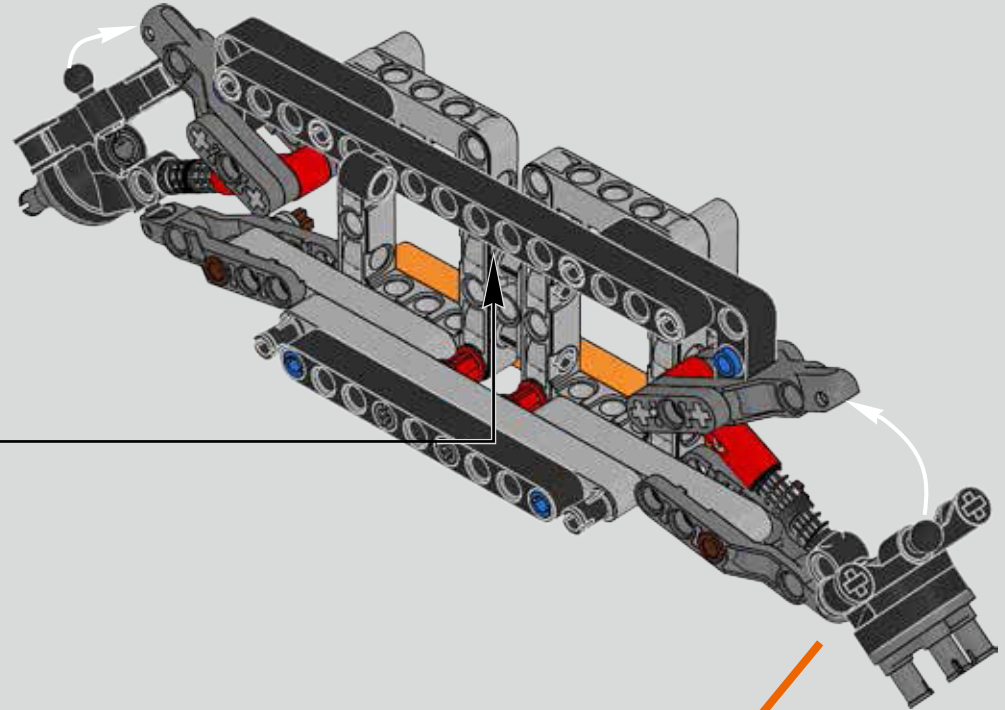



195

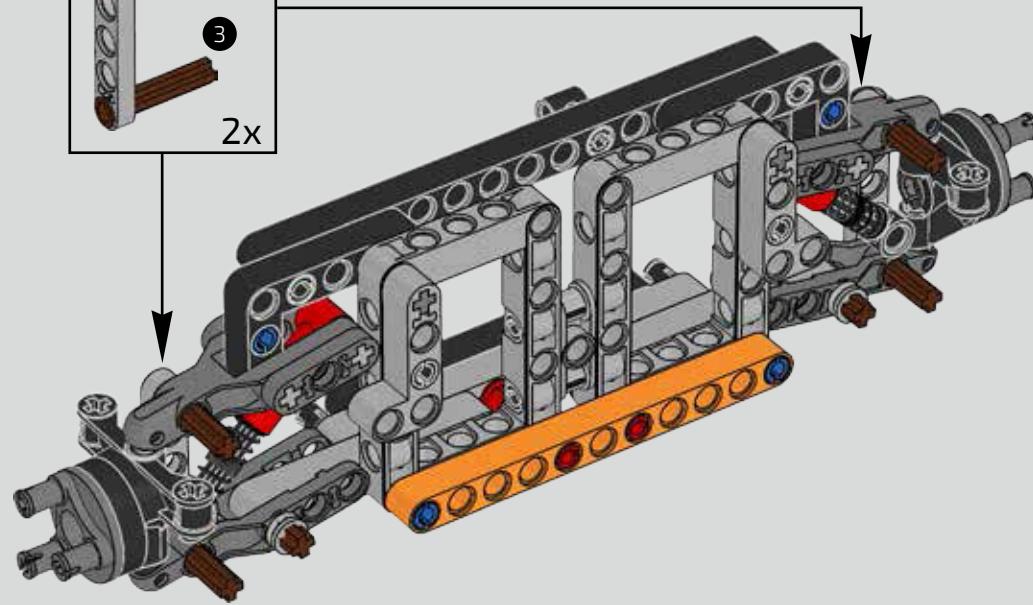
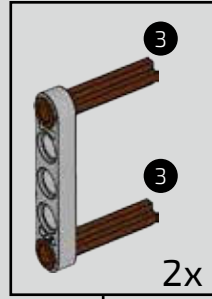
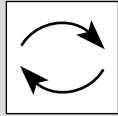

196

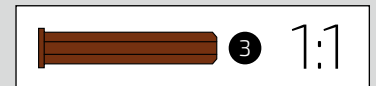
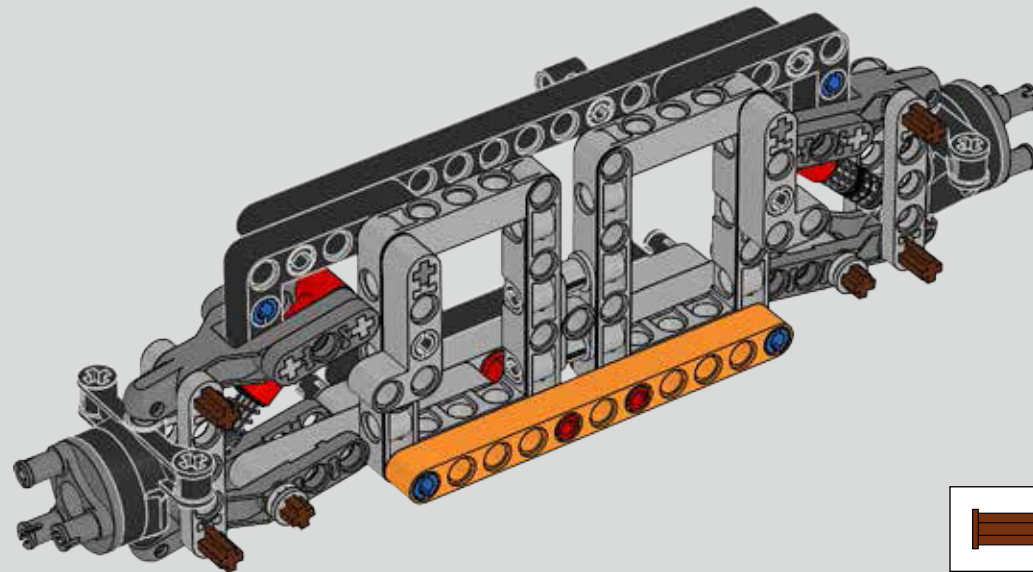



197

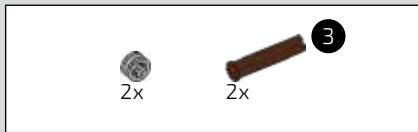
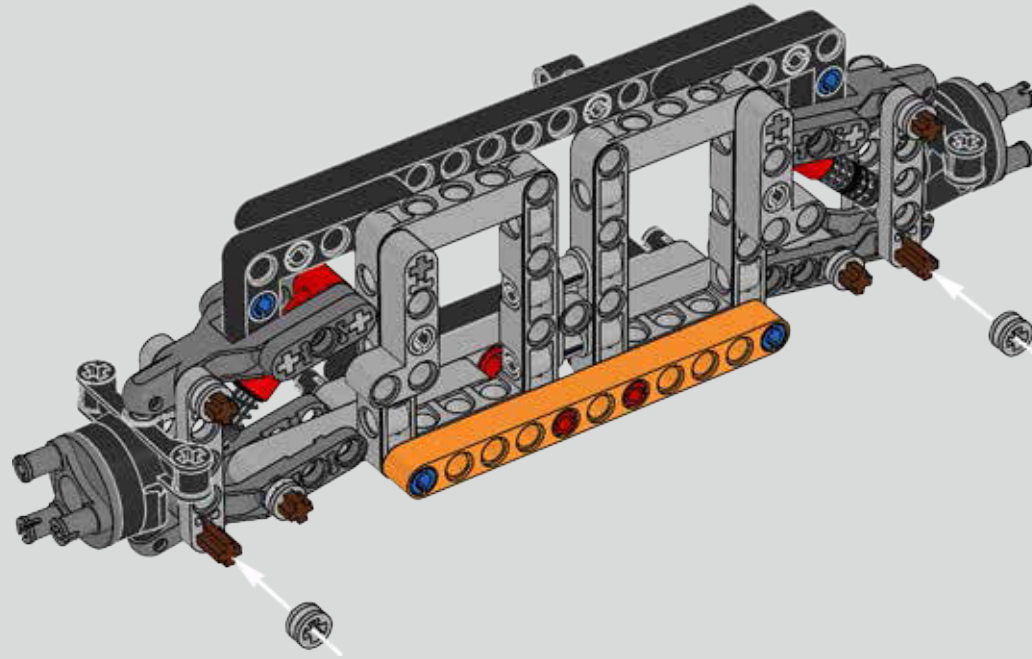

198

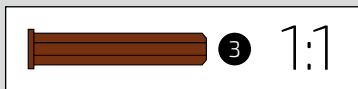
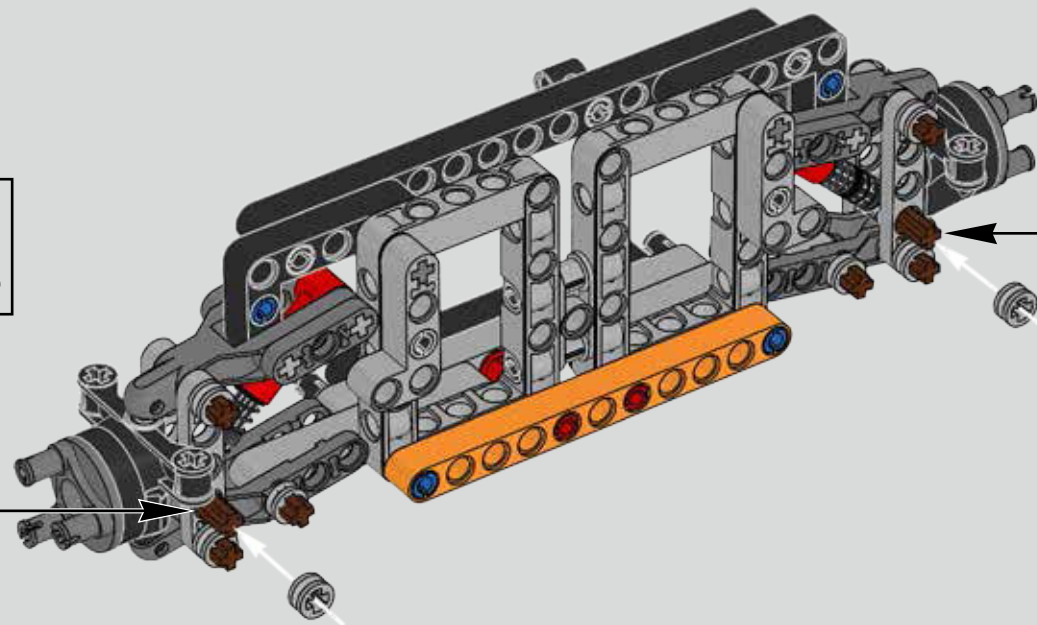

199

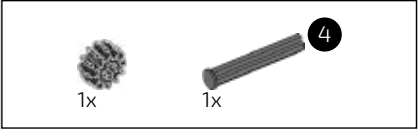
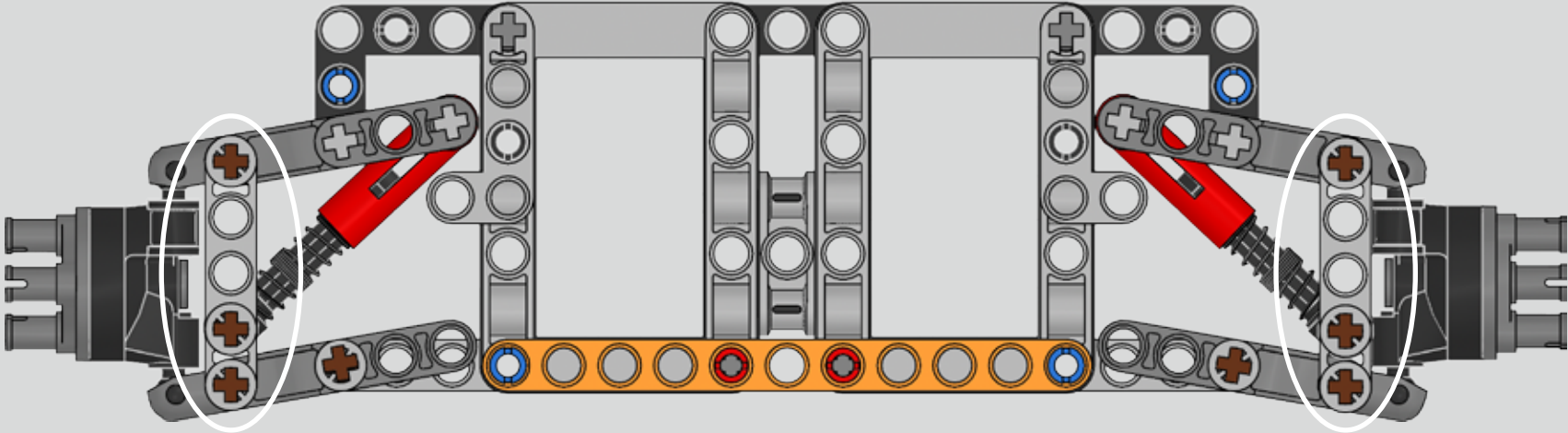

200

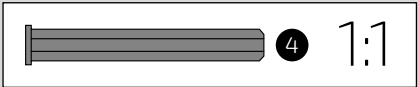
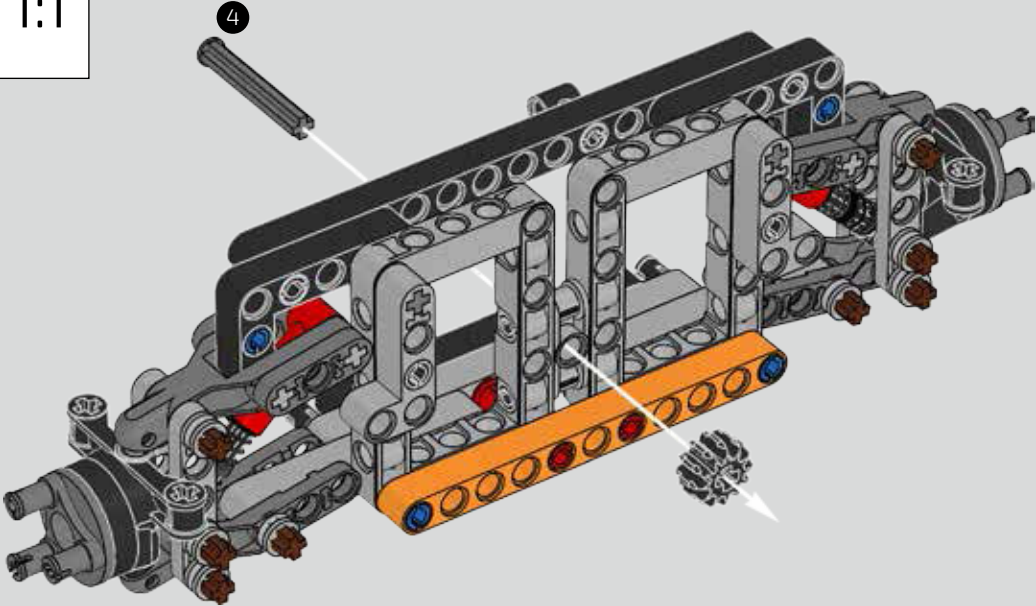

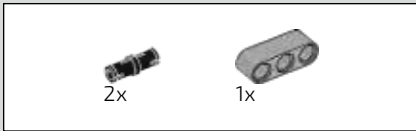

201

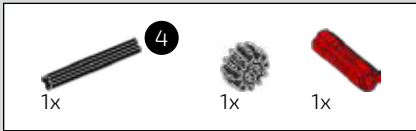
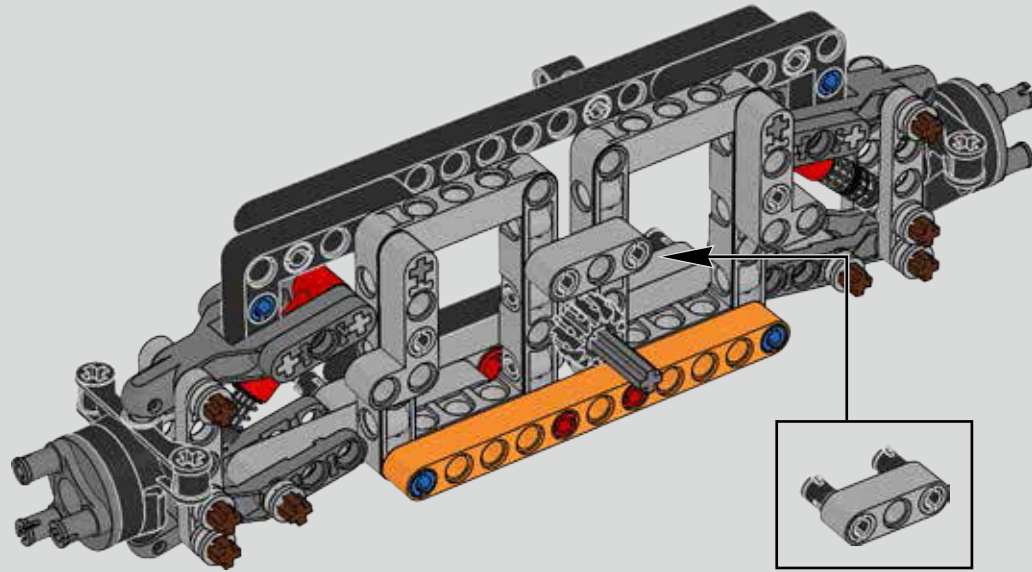

202

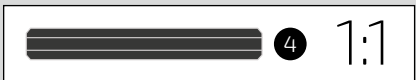
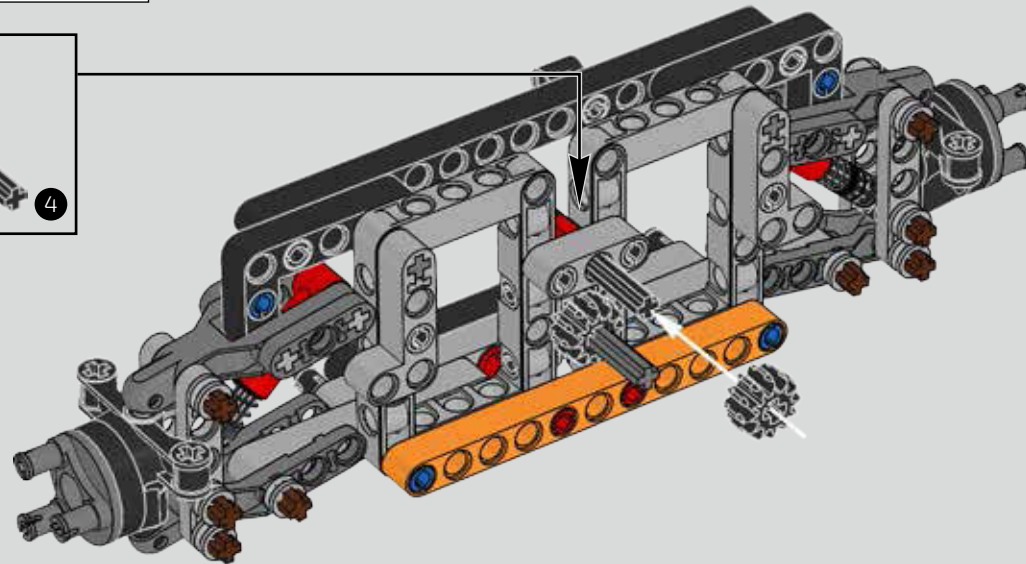
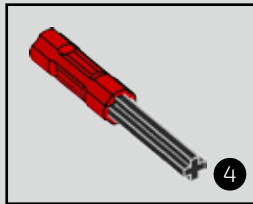

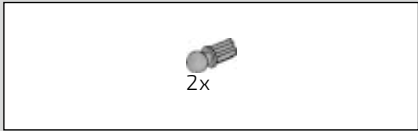

203

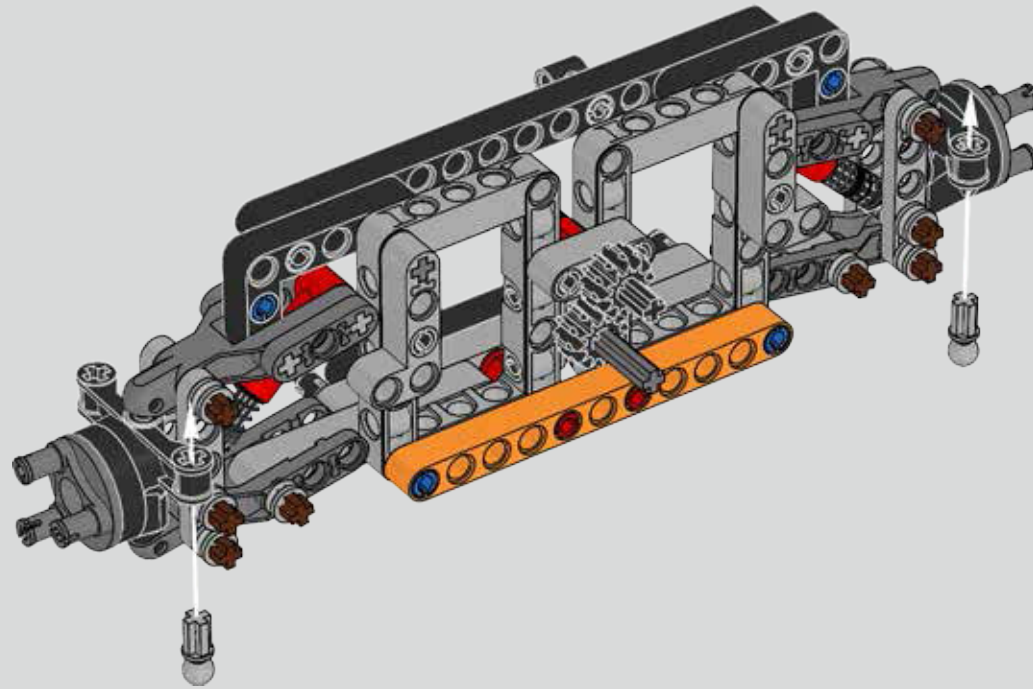

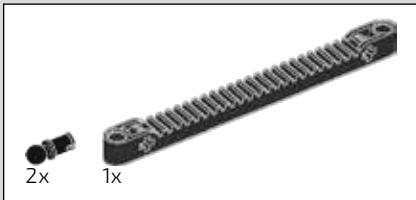
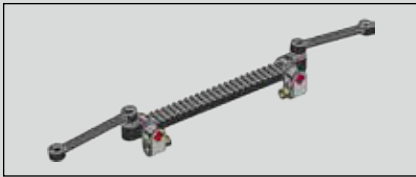

204

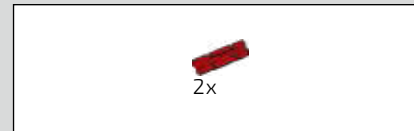

205

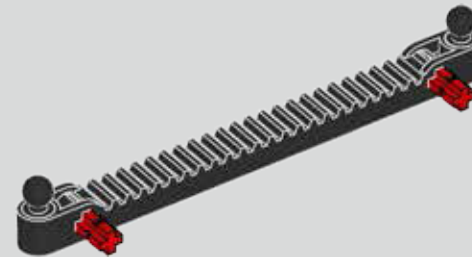

206

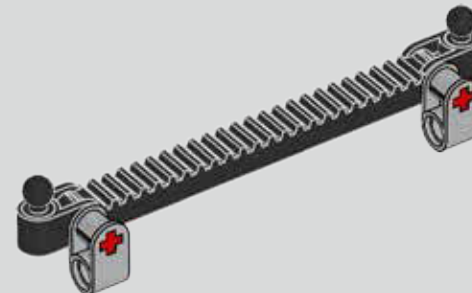



207

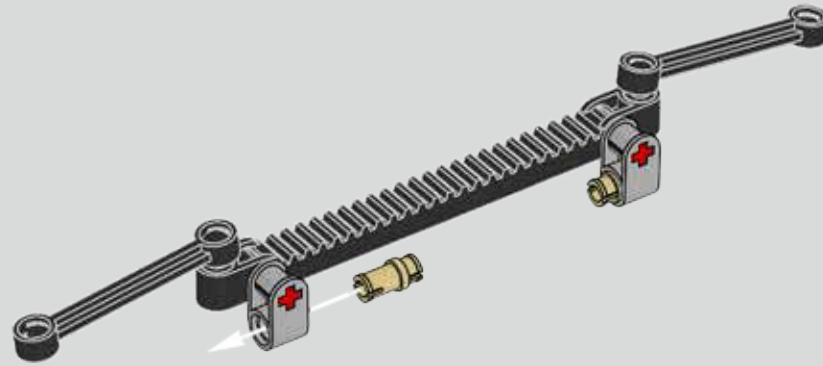

208

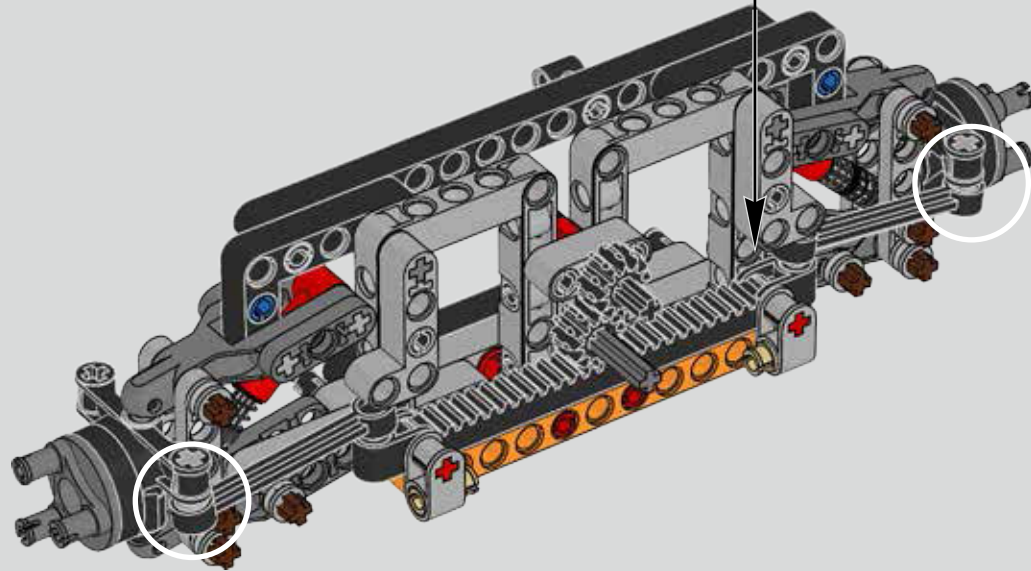

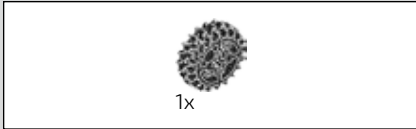

209

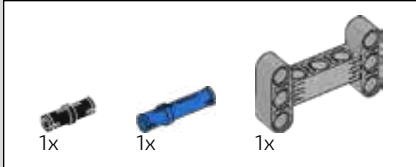
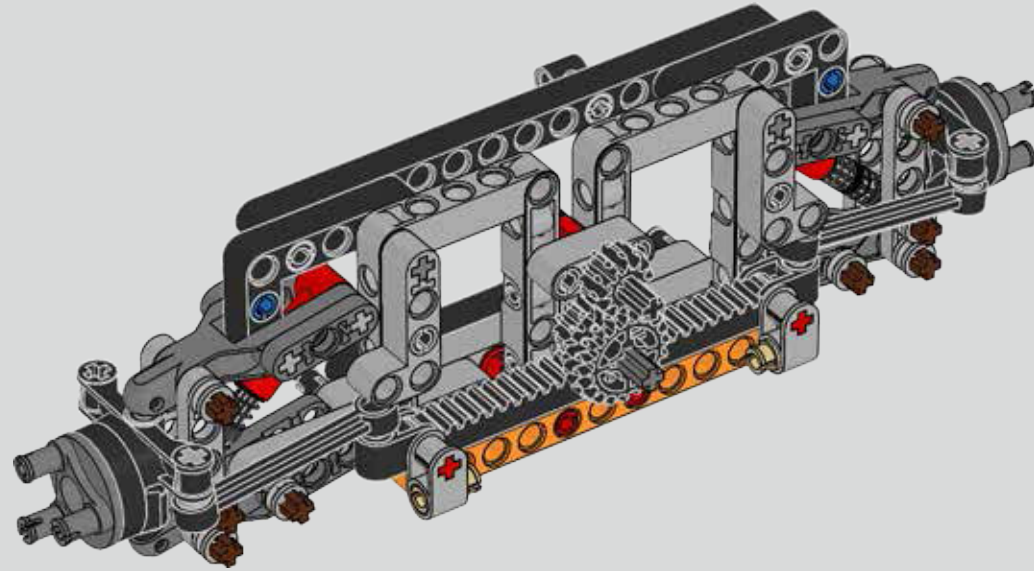

210

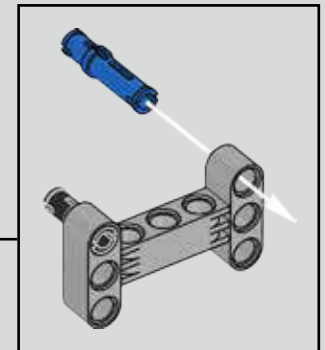
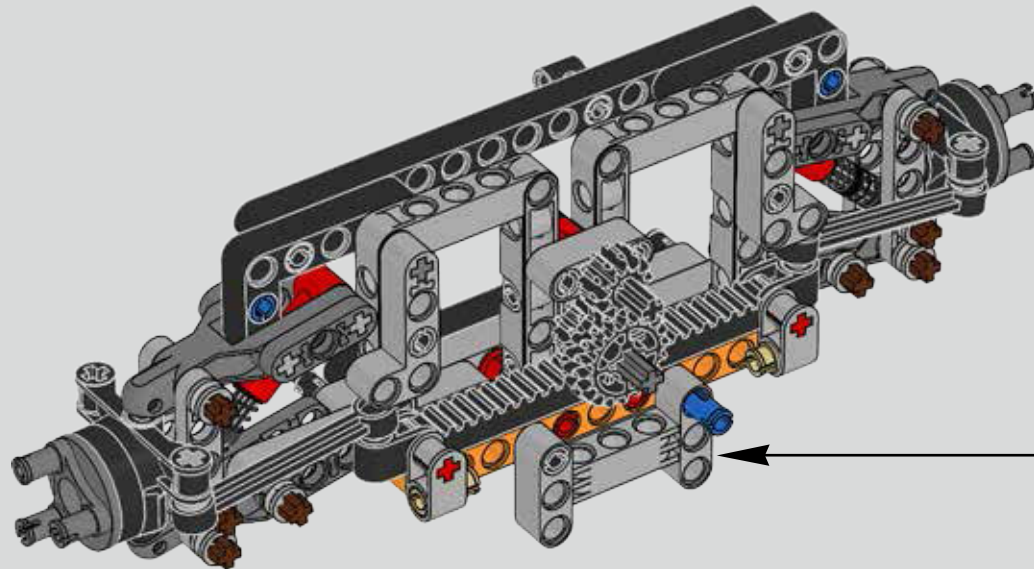

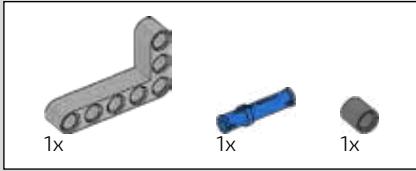

211

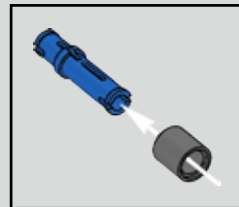
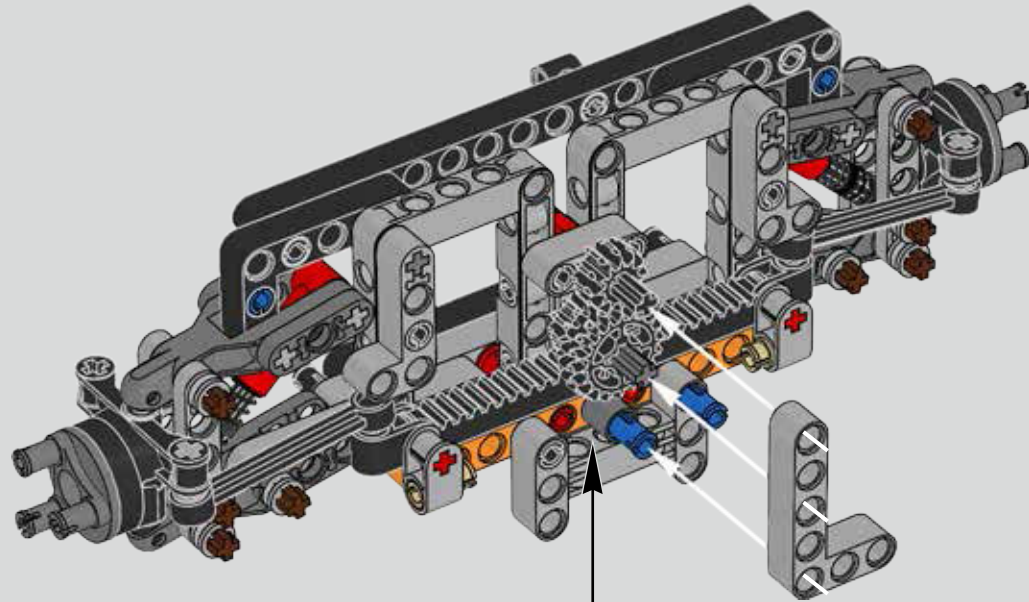

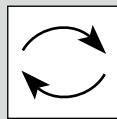
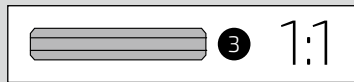
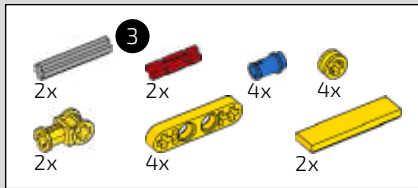

212

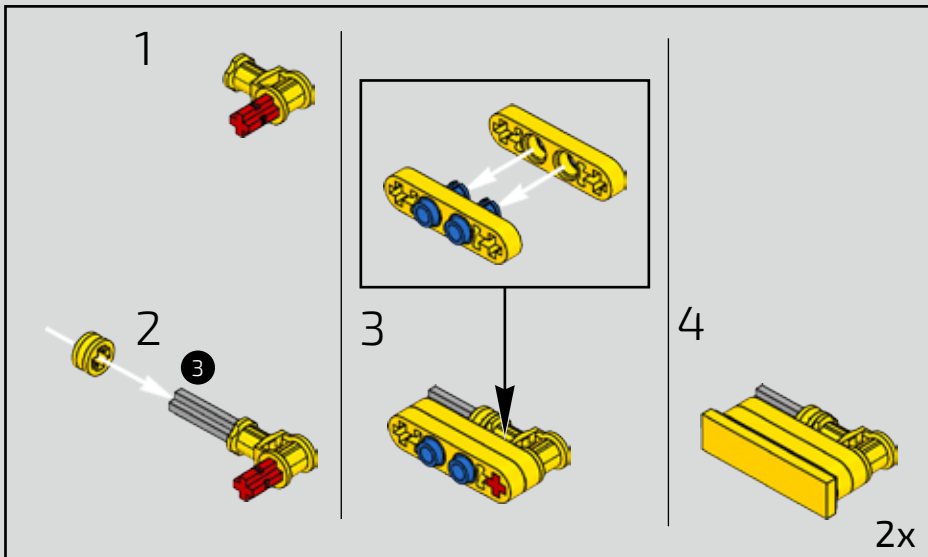
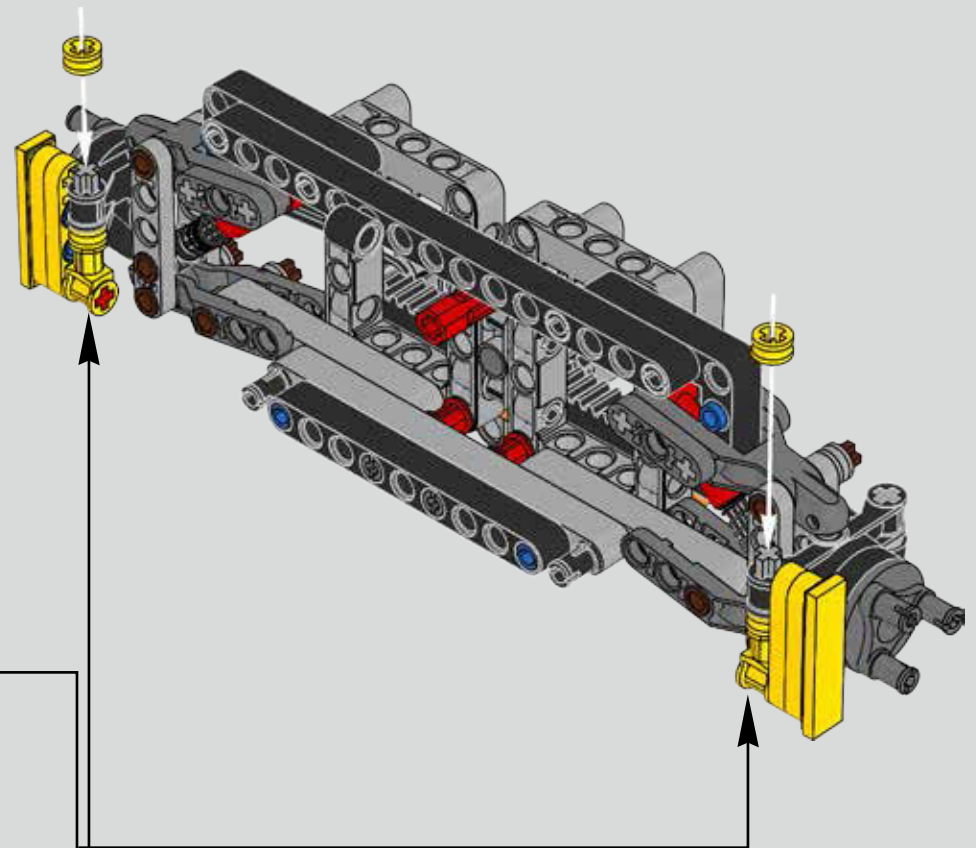

213

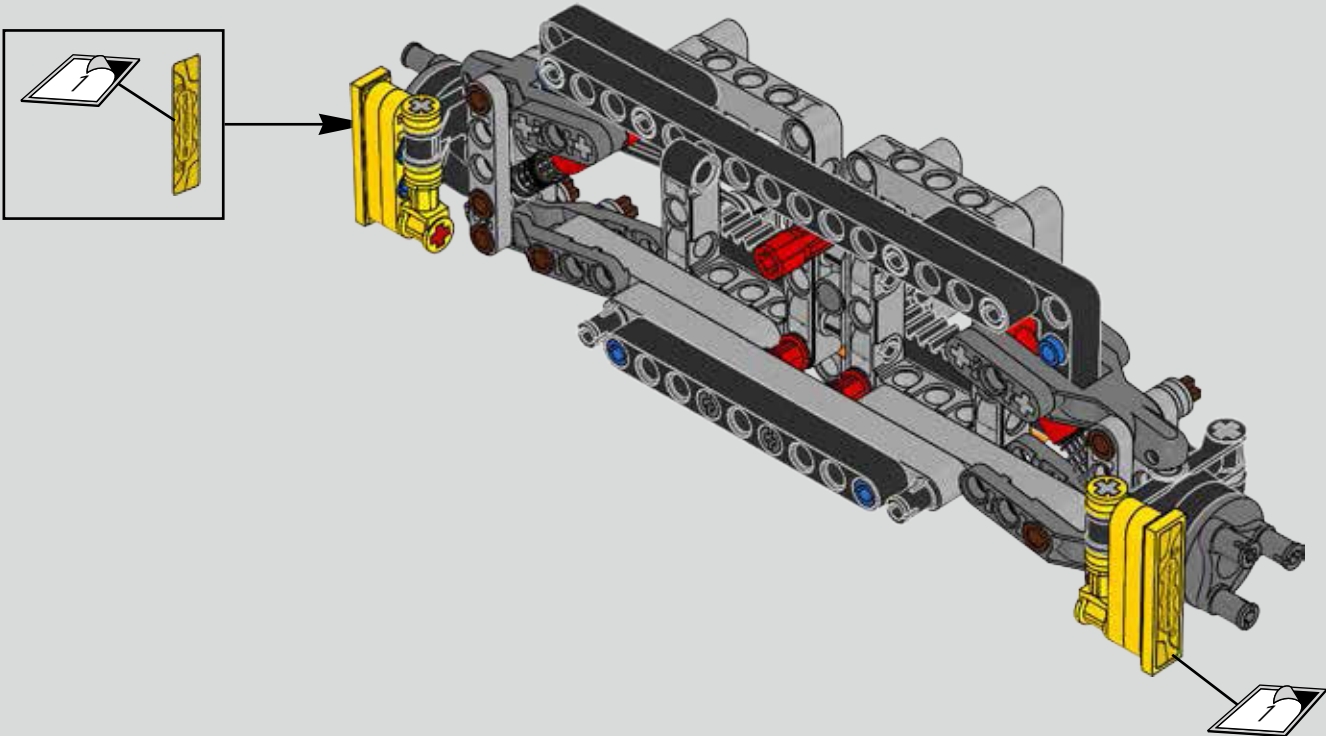

214

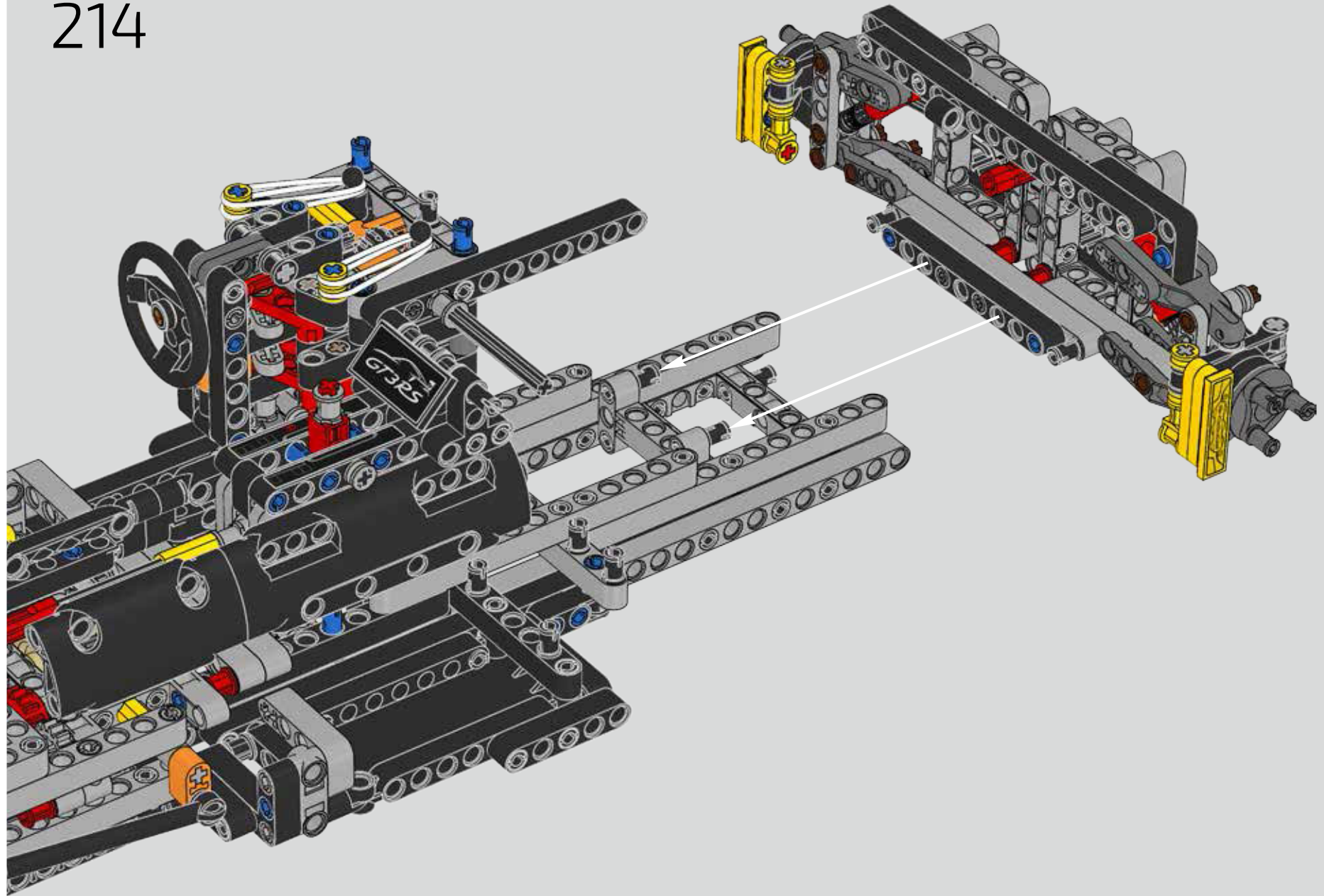

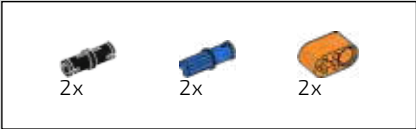

215

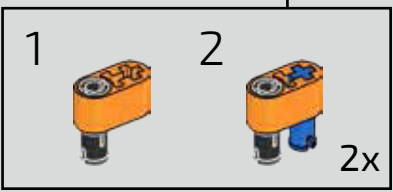
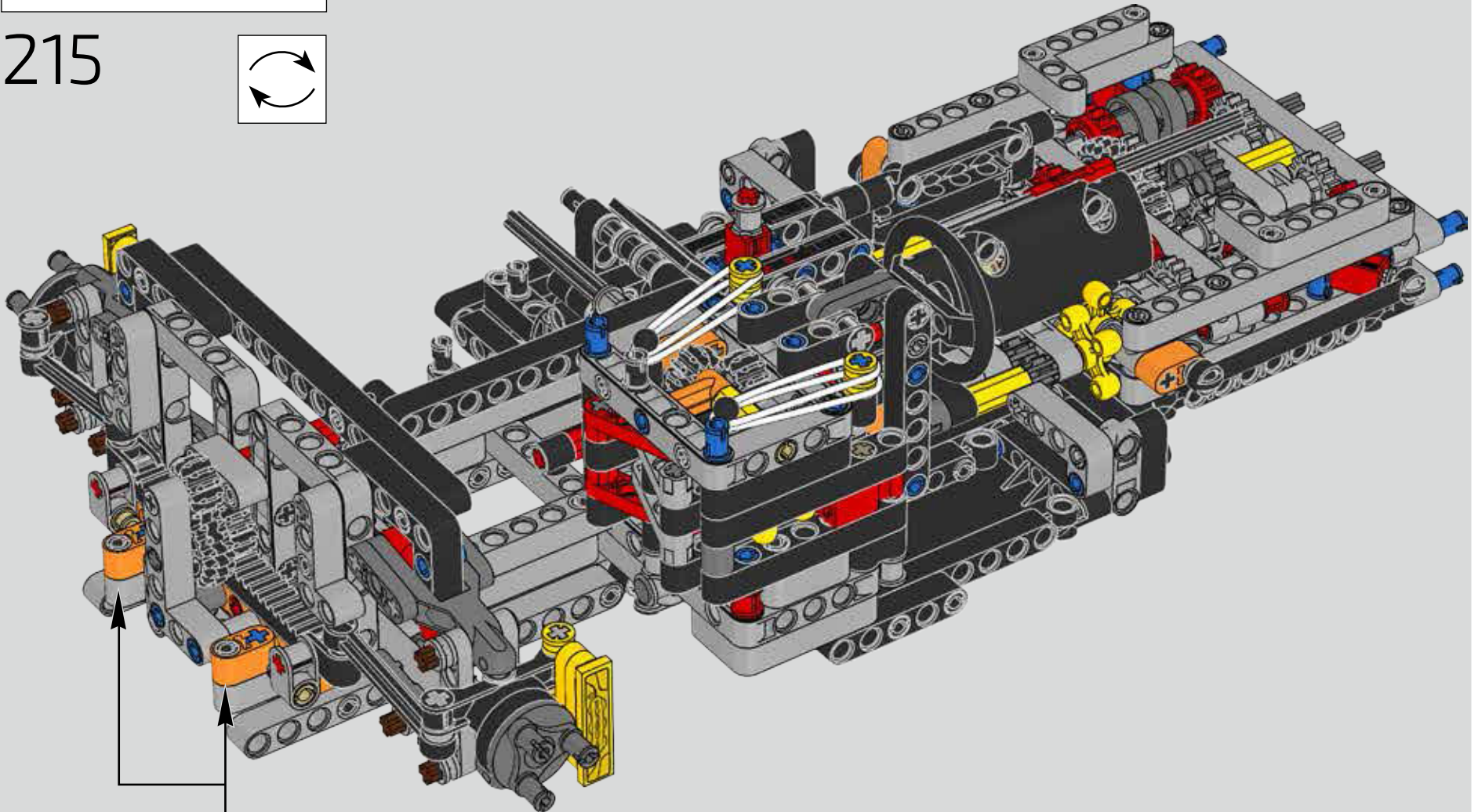
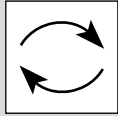

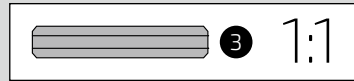
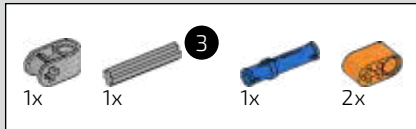

216

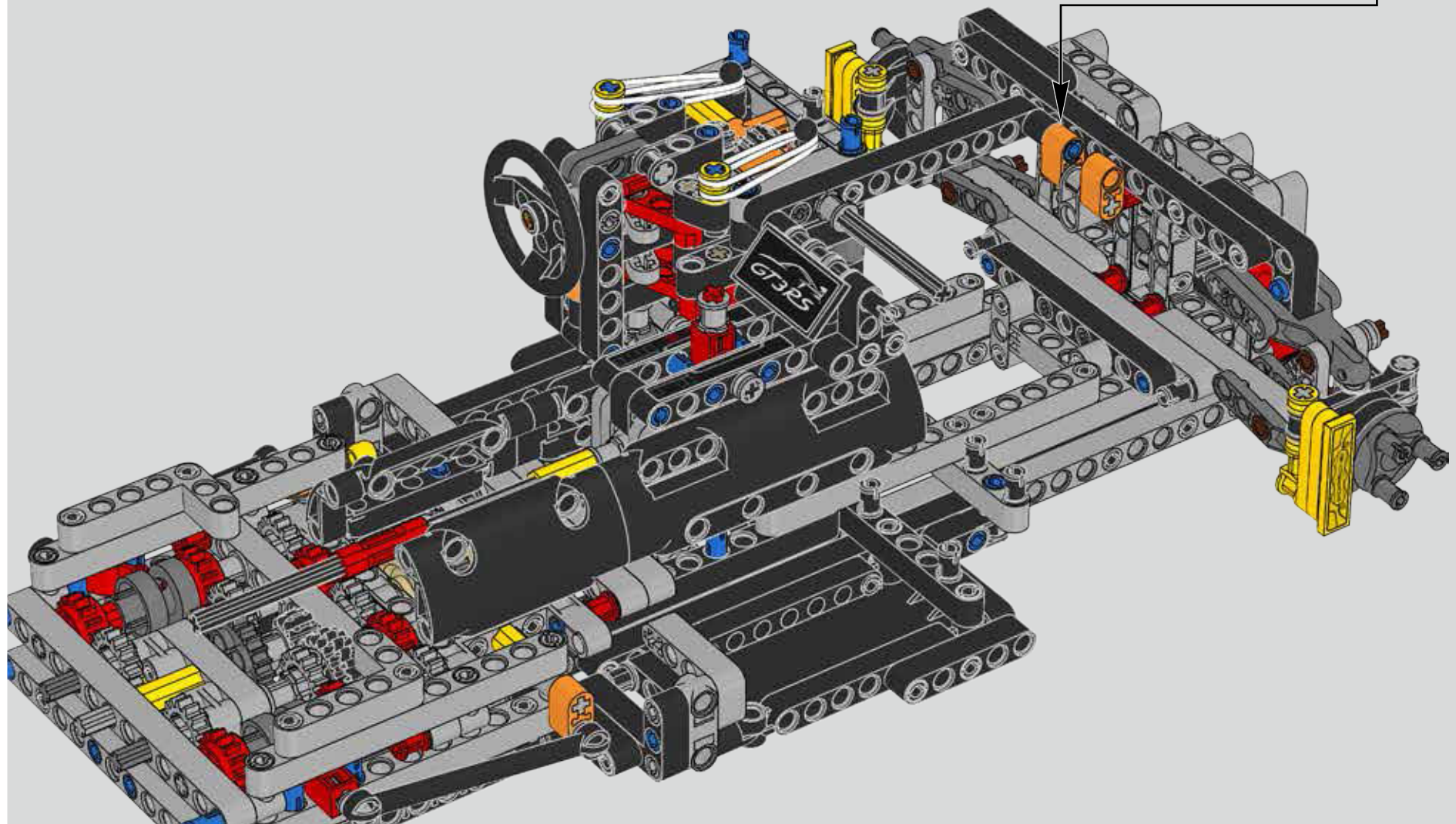
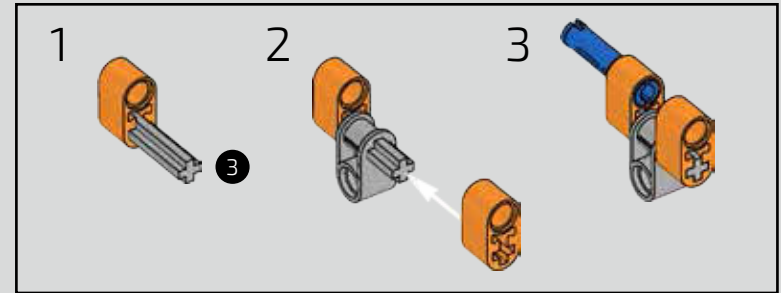
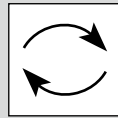

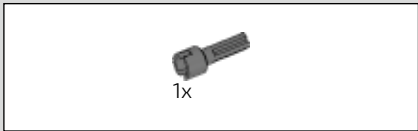

217

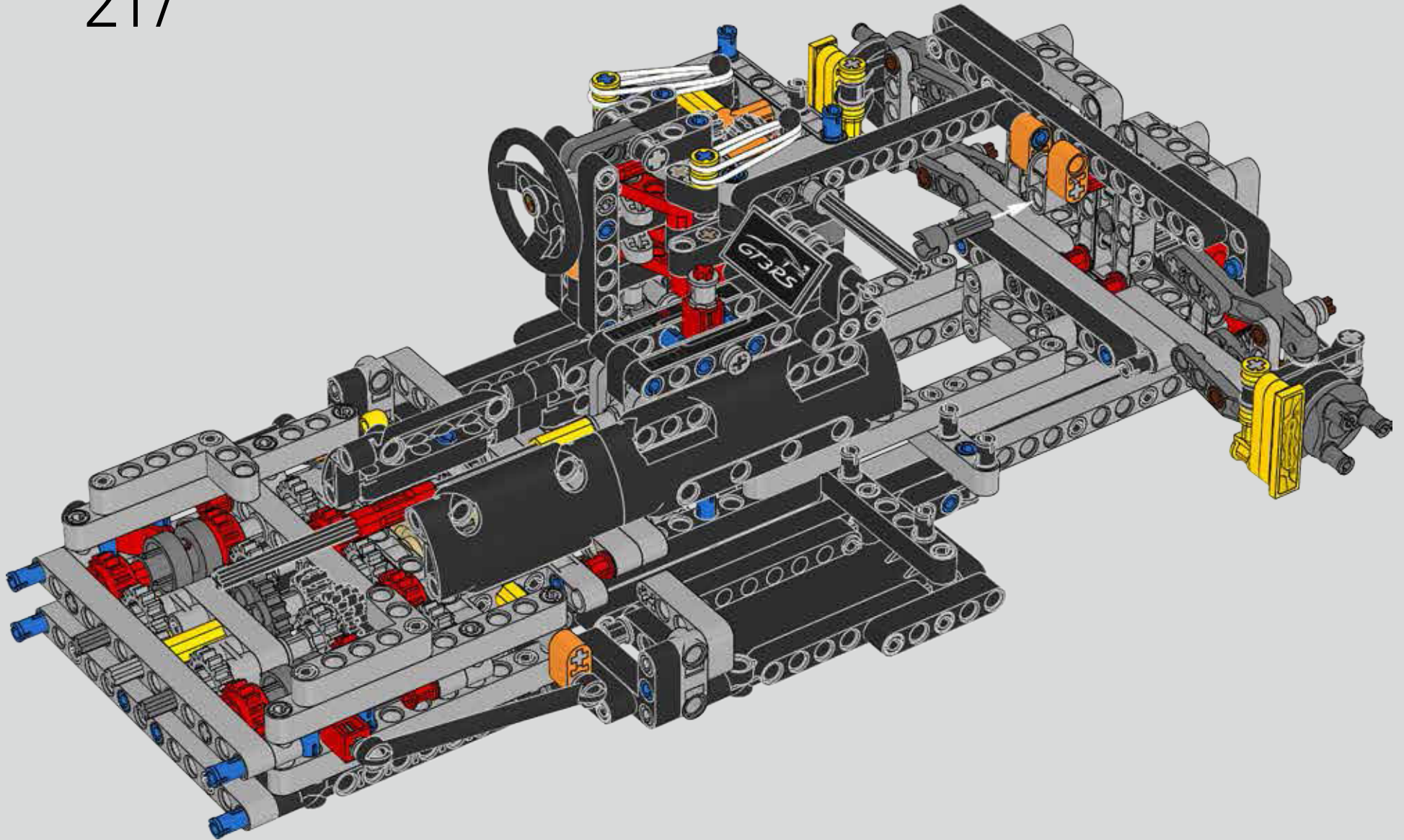

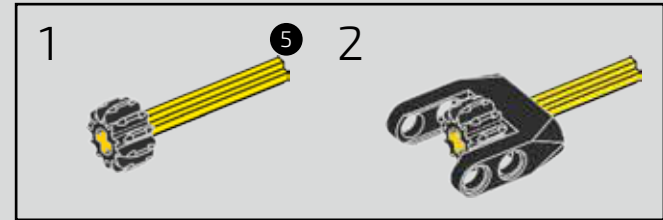
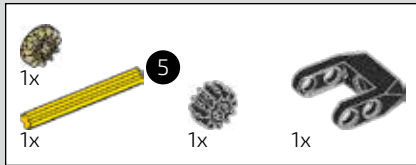

218

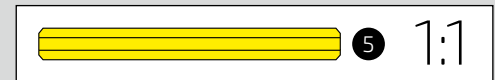
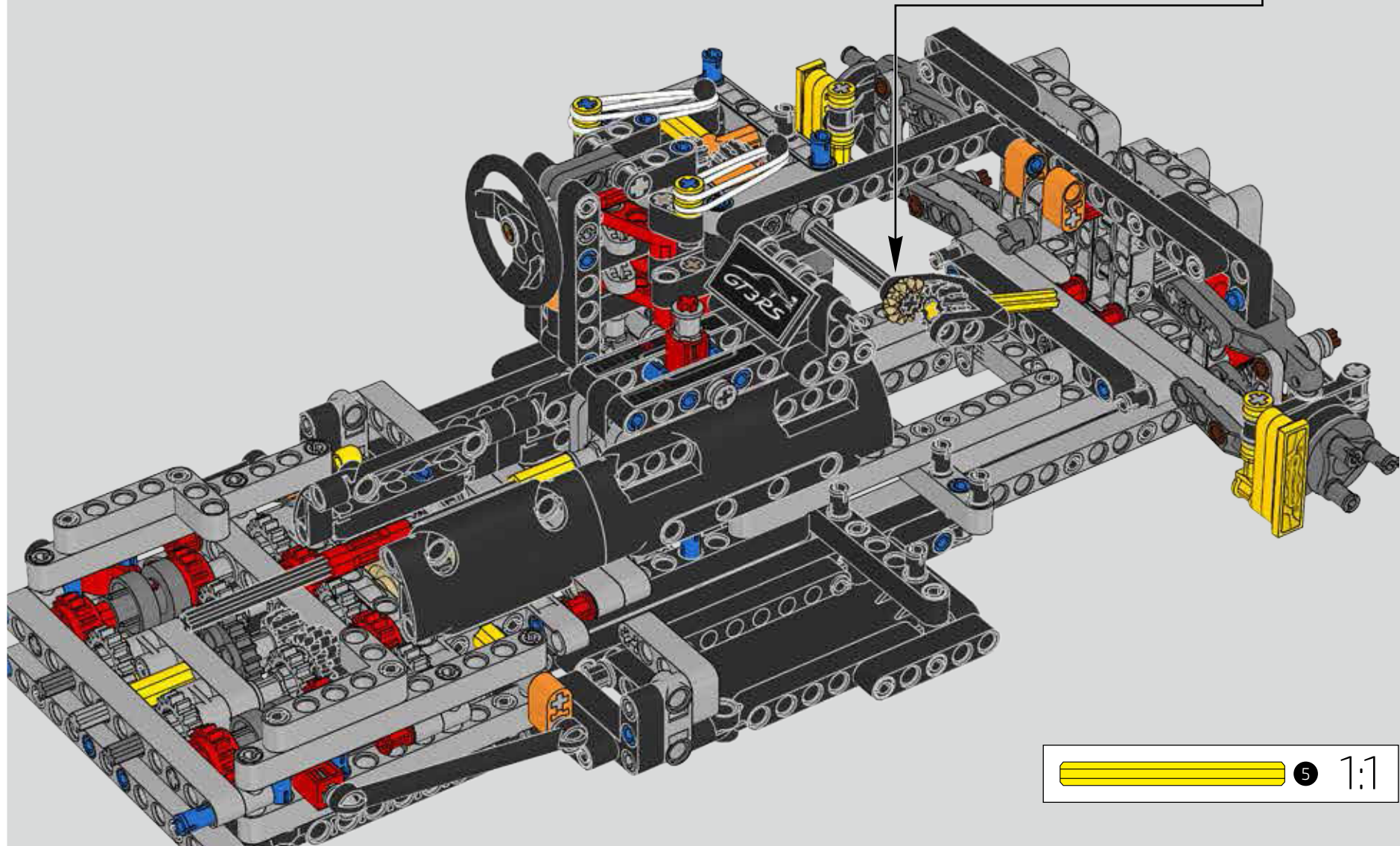

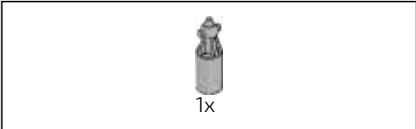

219

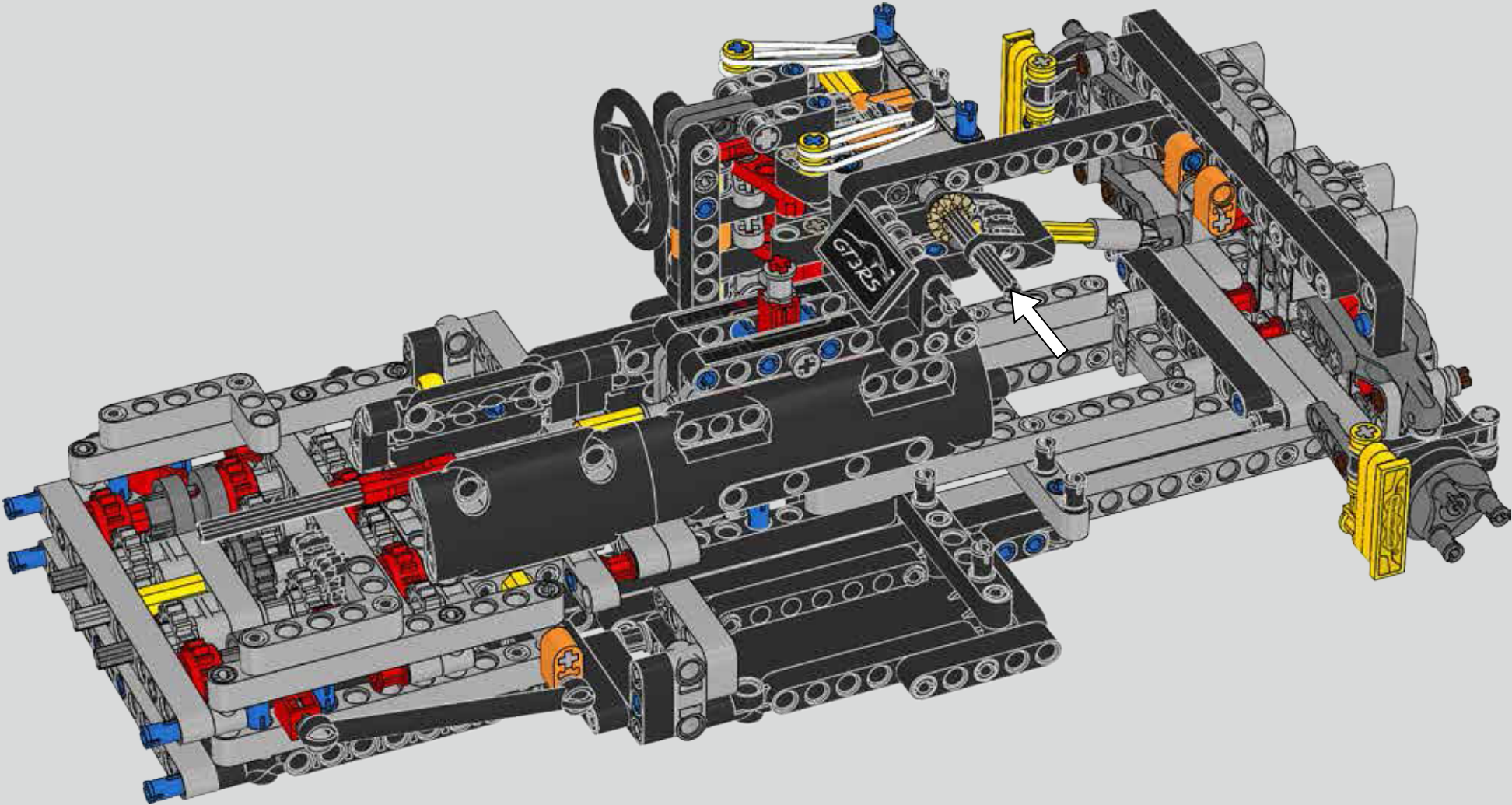

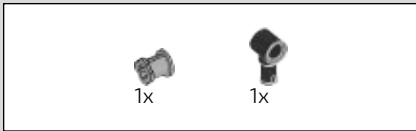

220

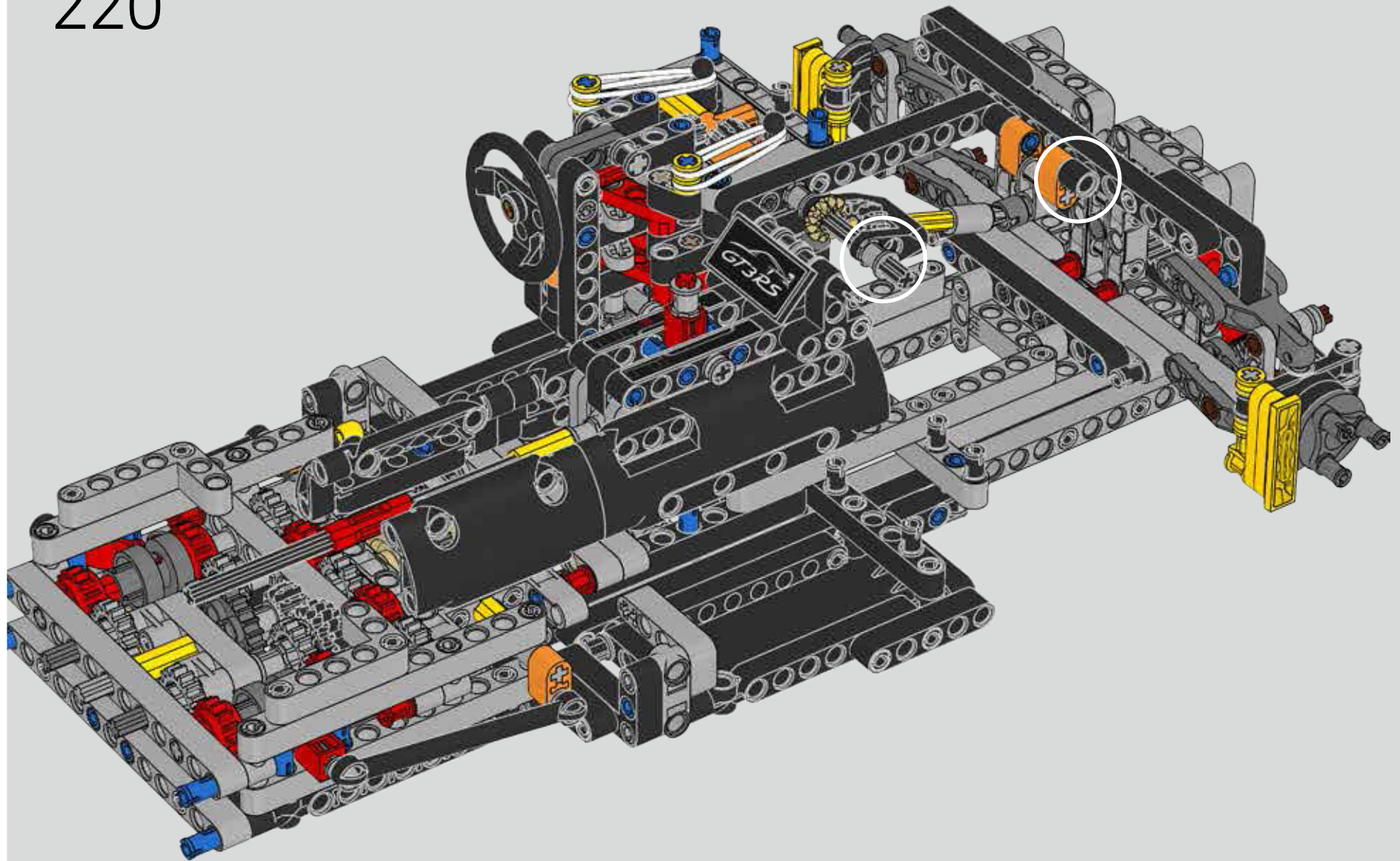

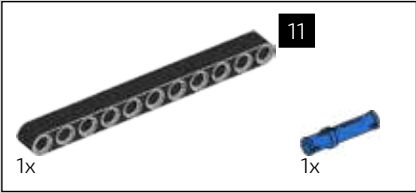

221

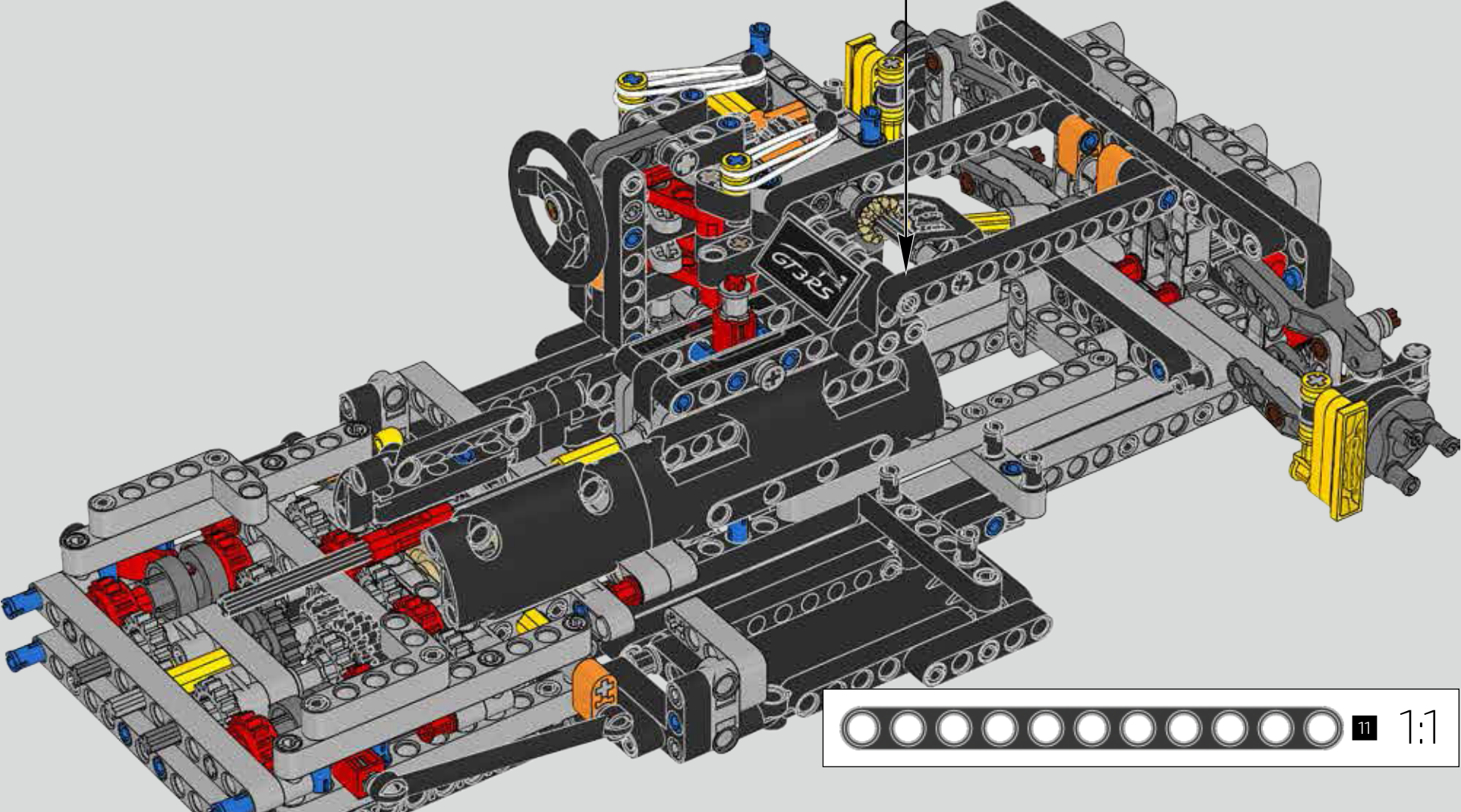
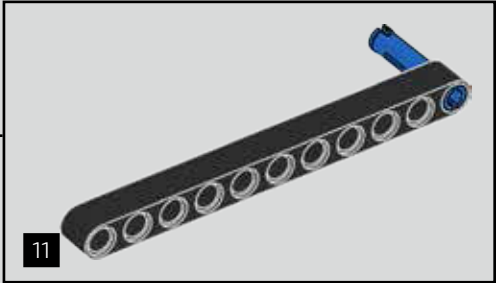

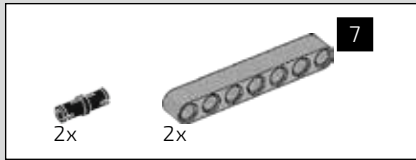

222

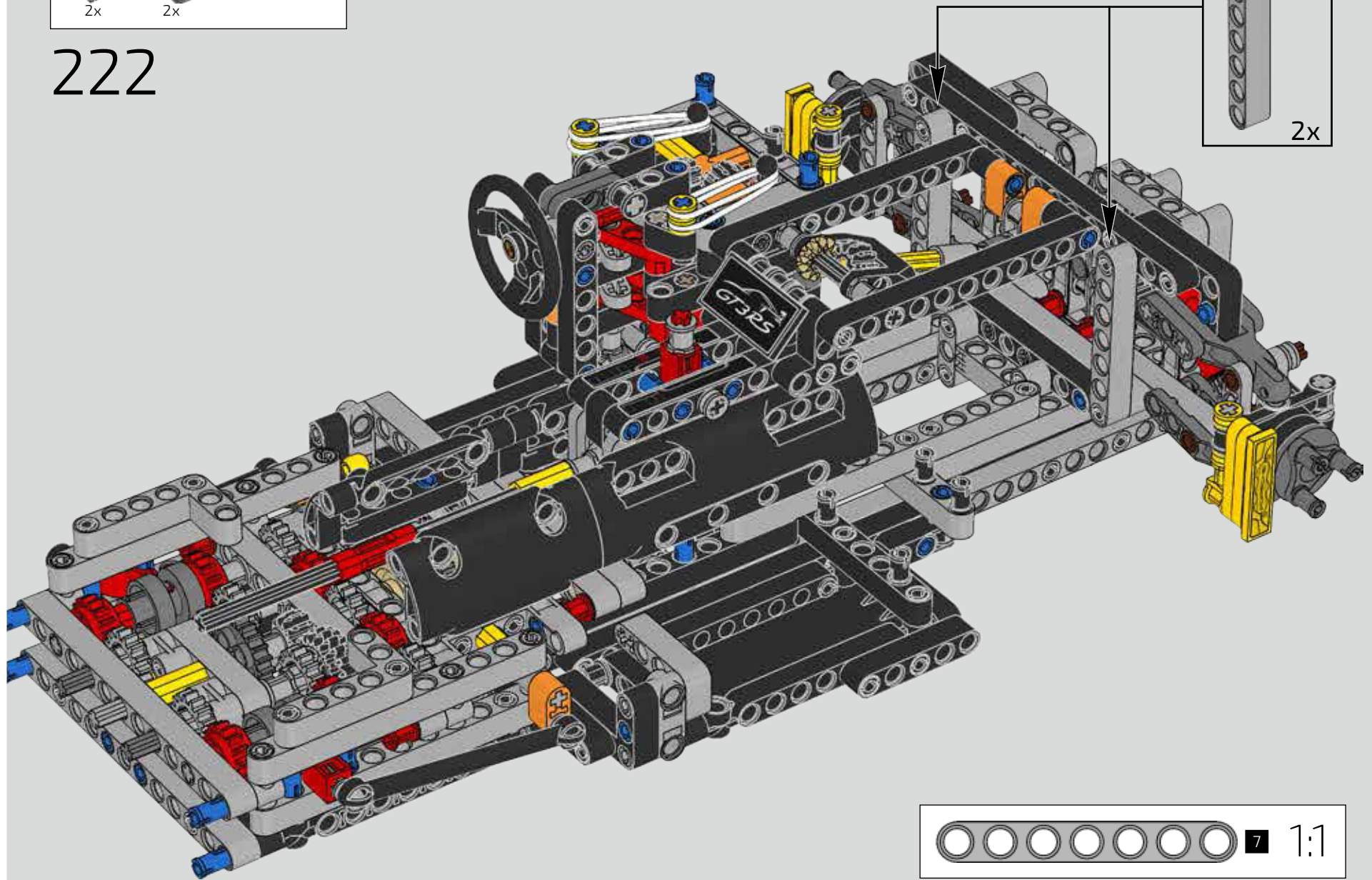
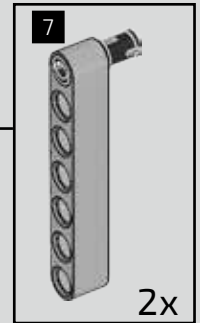

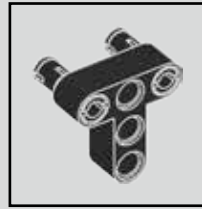
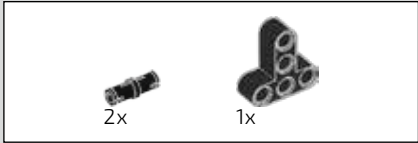

223

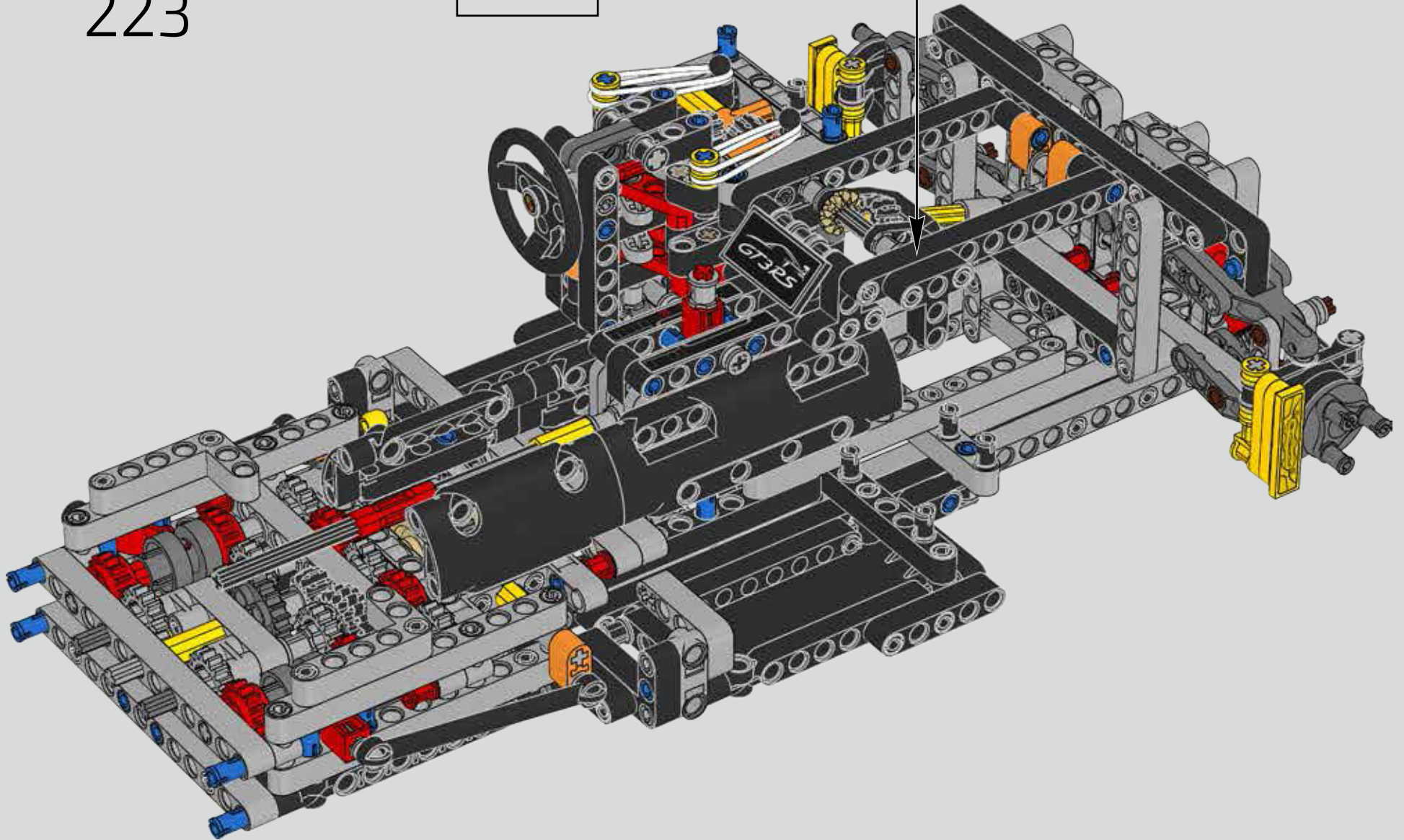

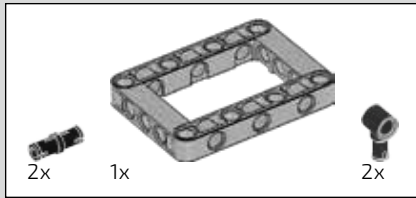

224

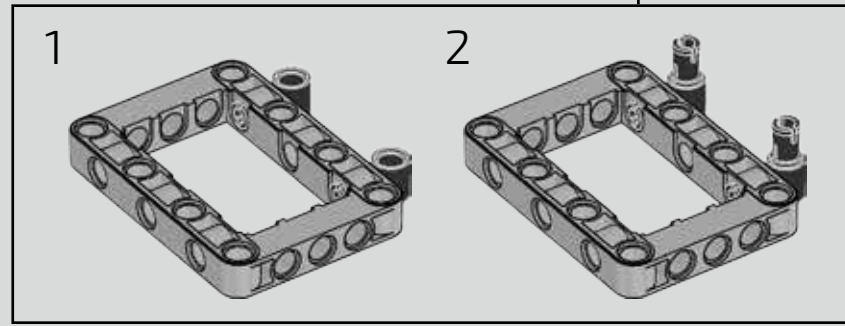
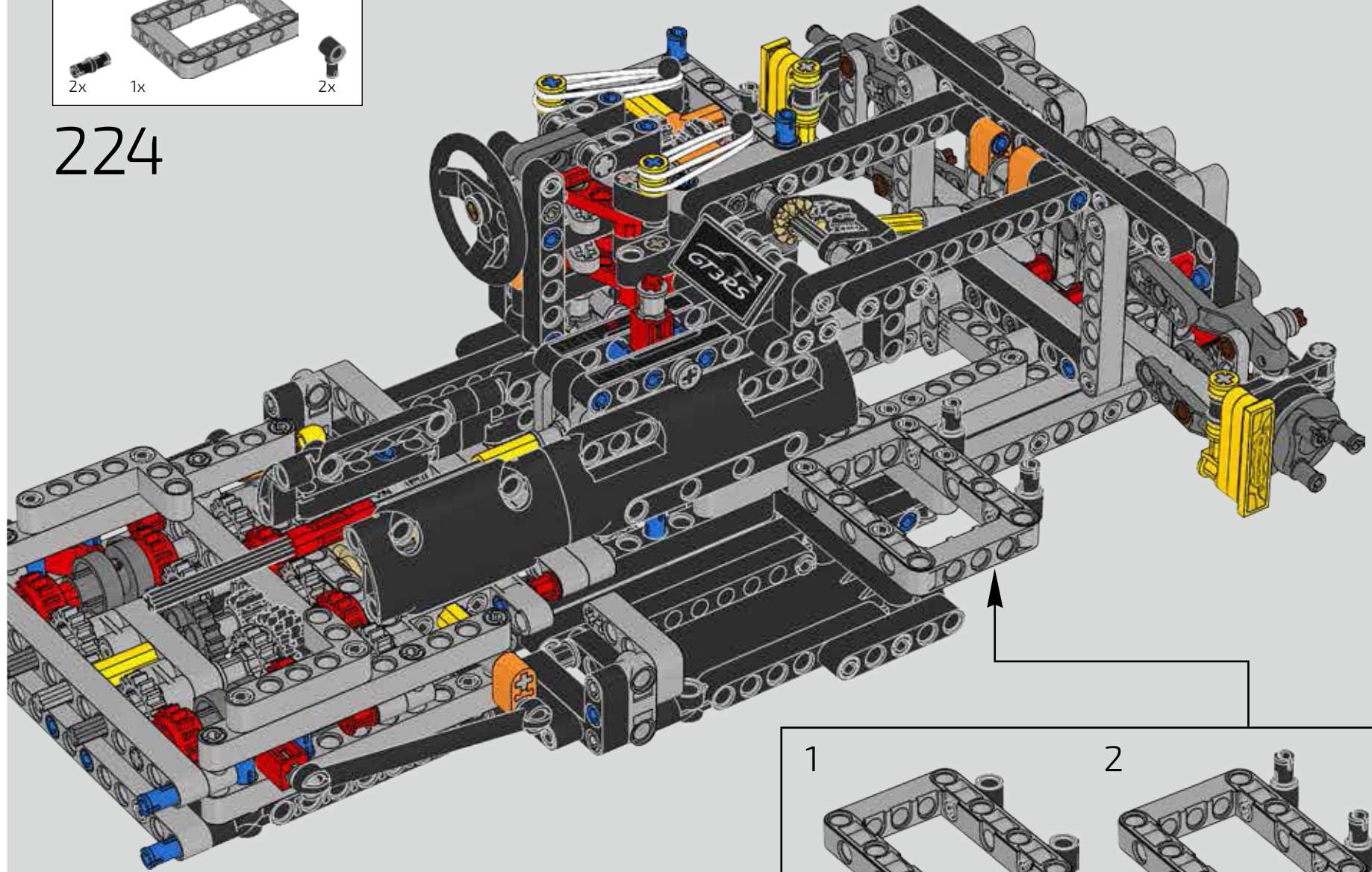

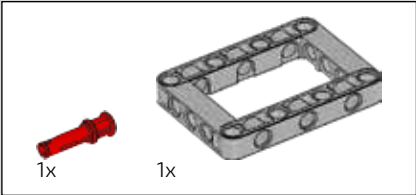

225

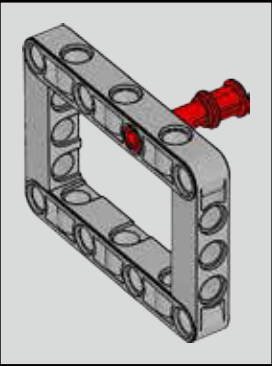
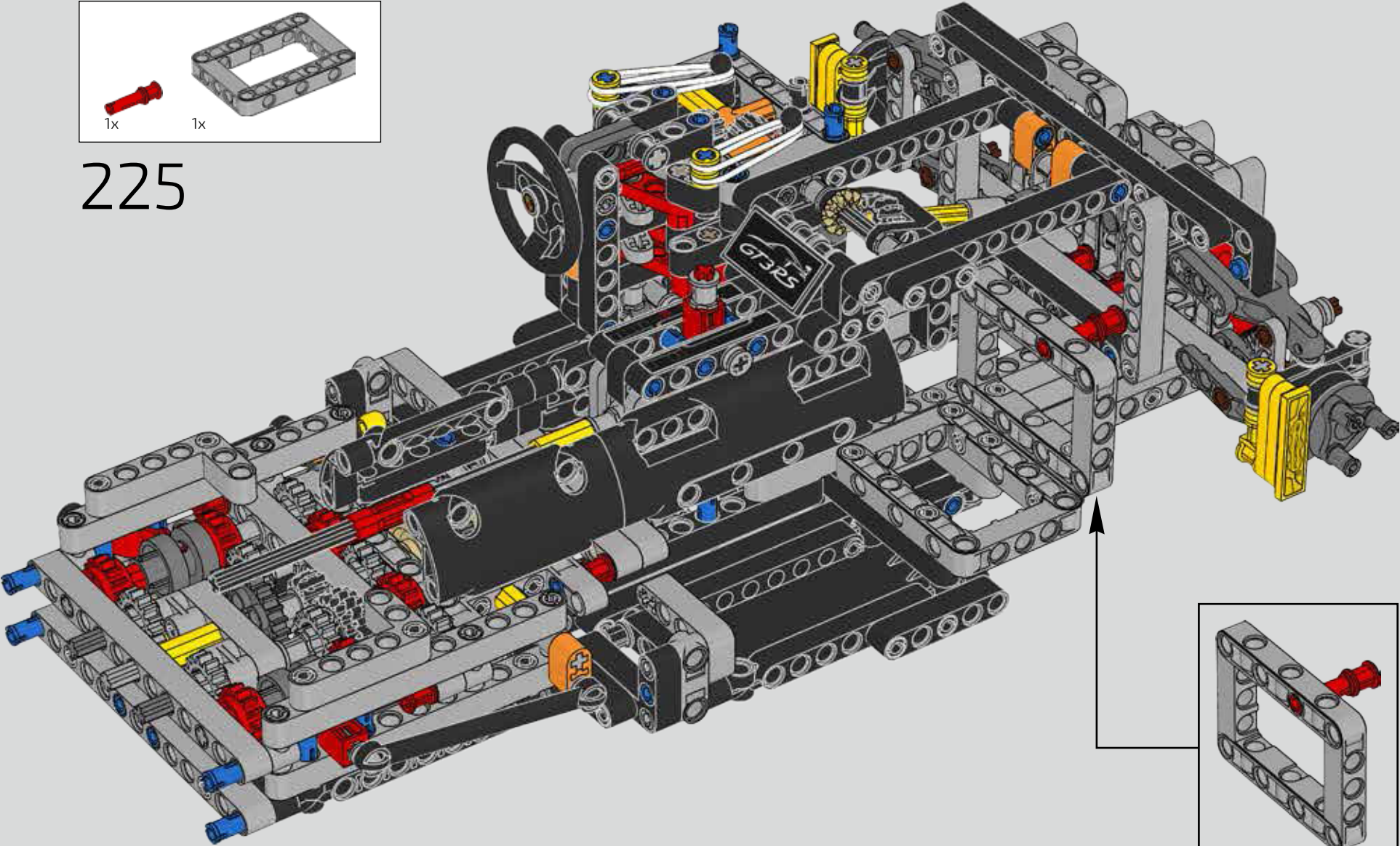



226

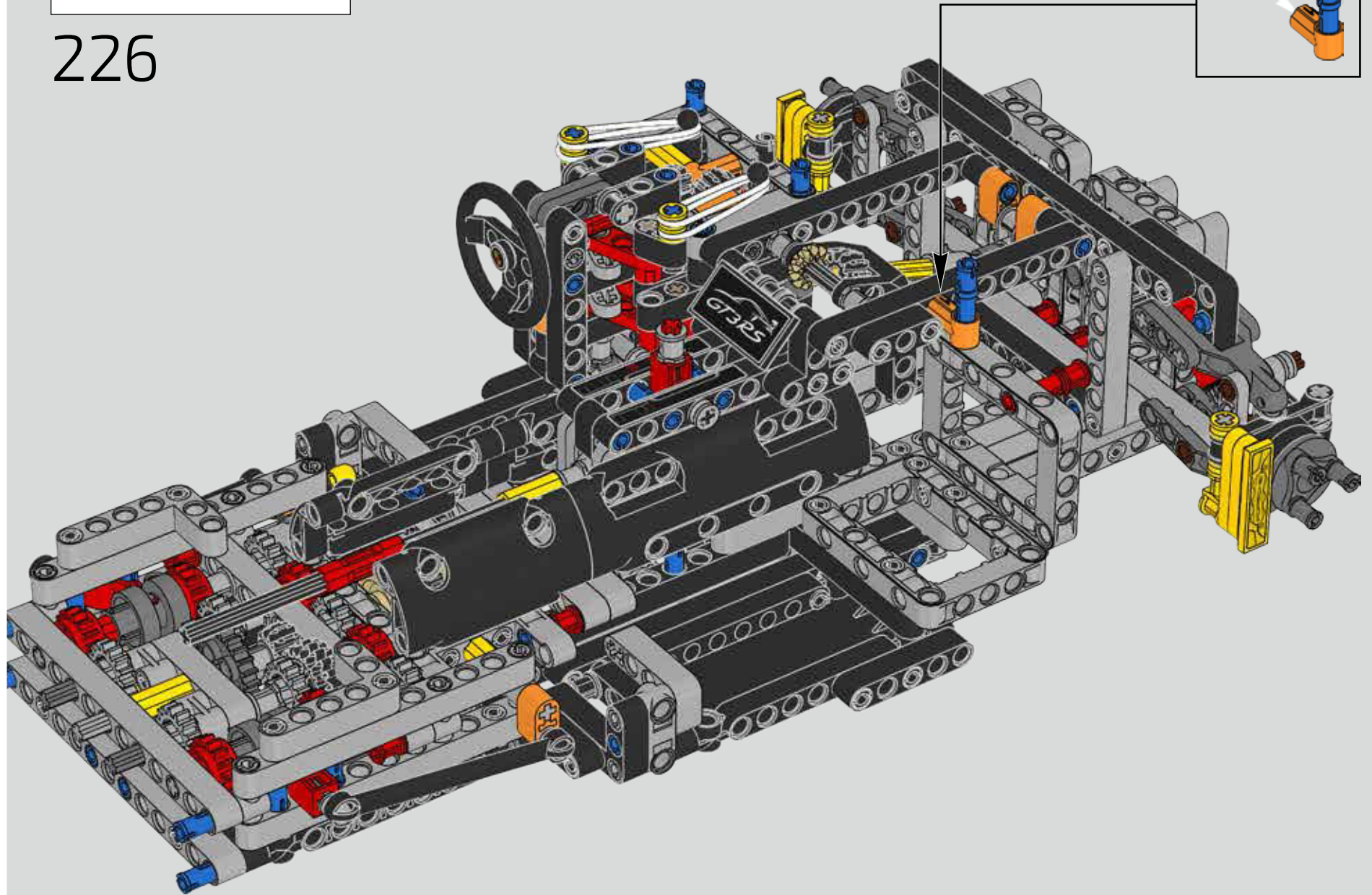
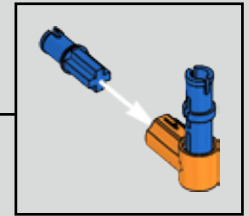



227

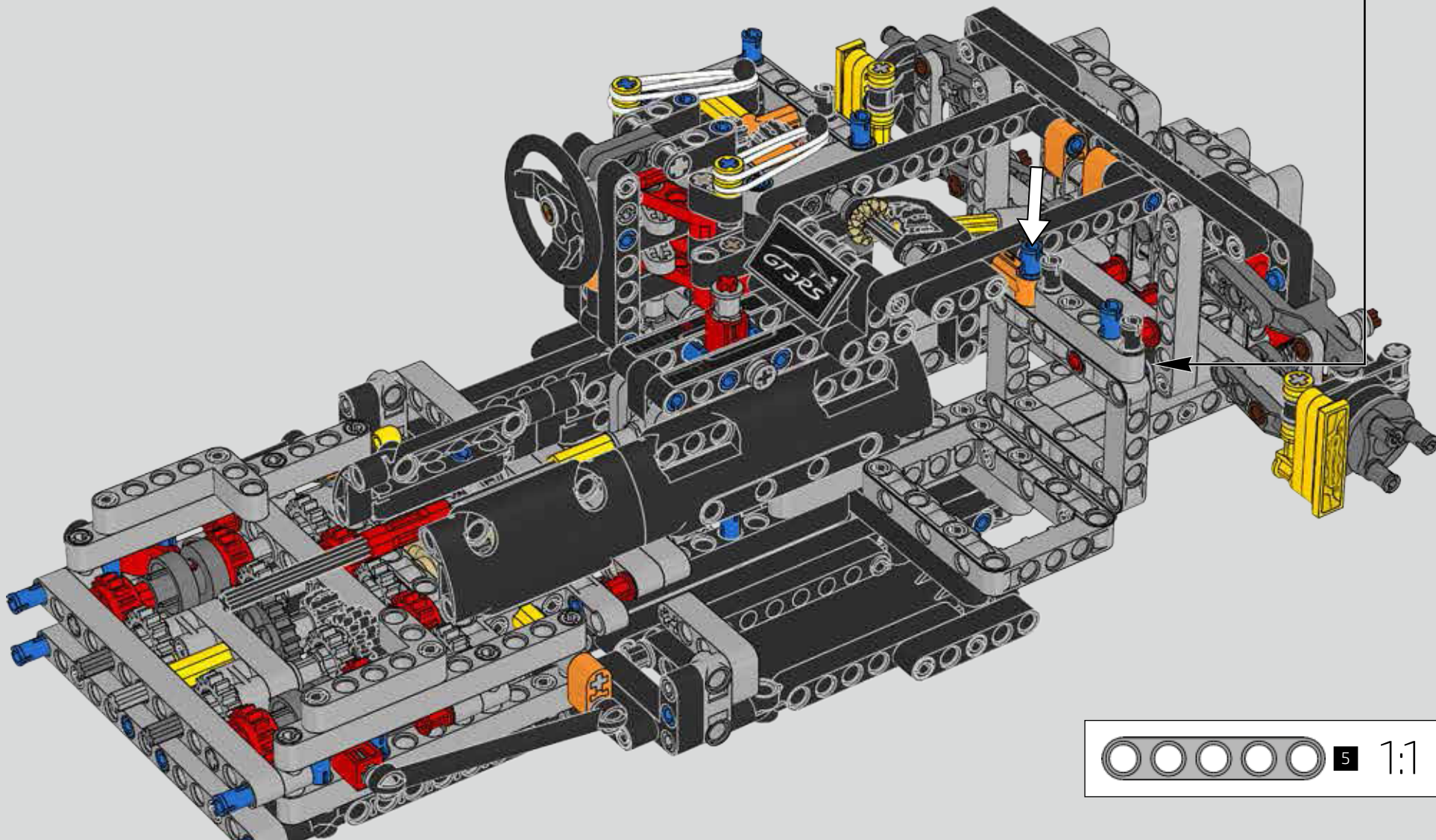
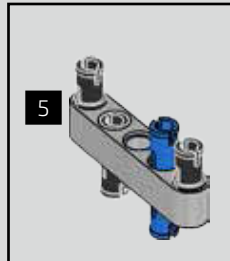

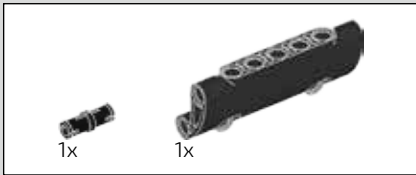
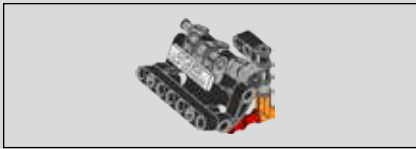

228

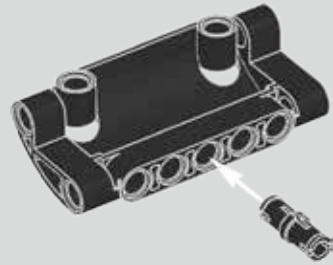

229

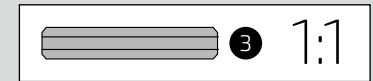
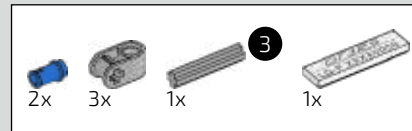
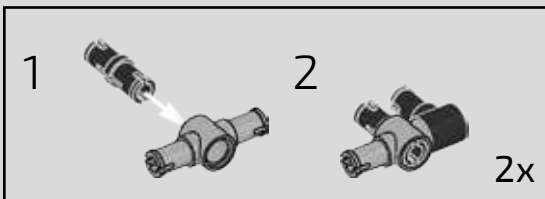
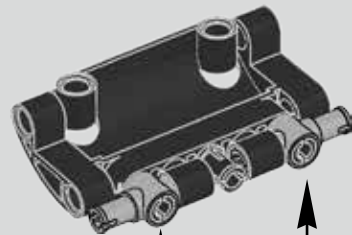

230

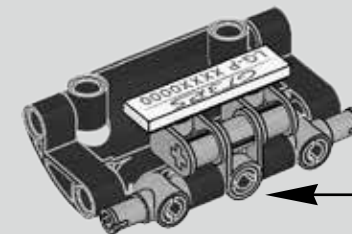
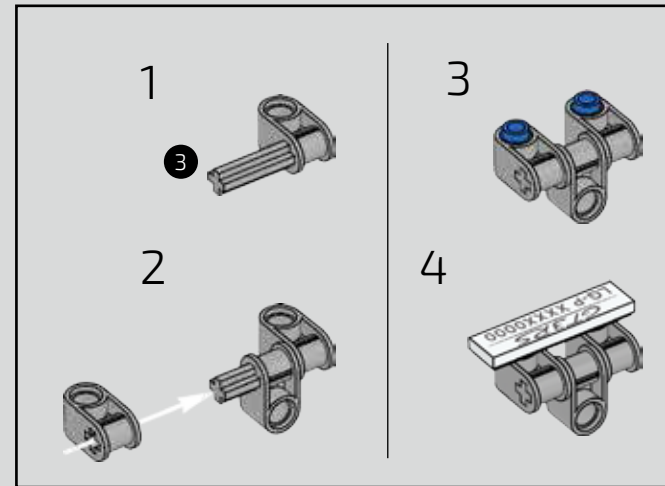

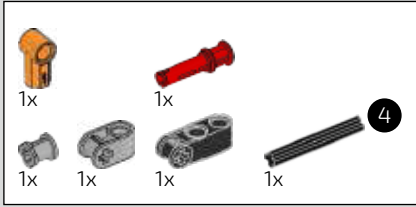

231

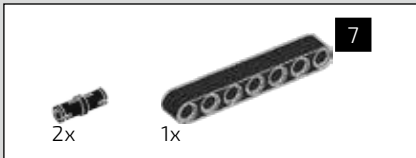
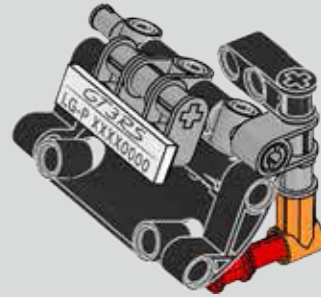
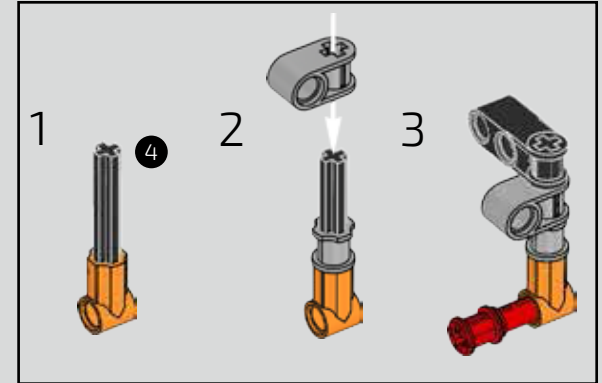
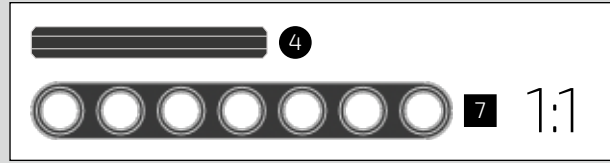
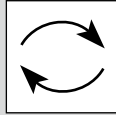

232

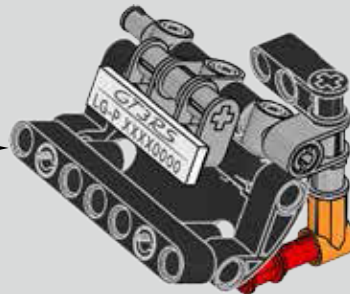
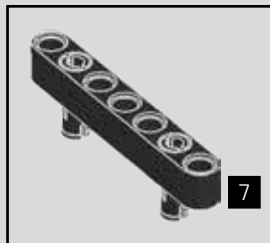

233

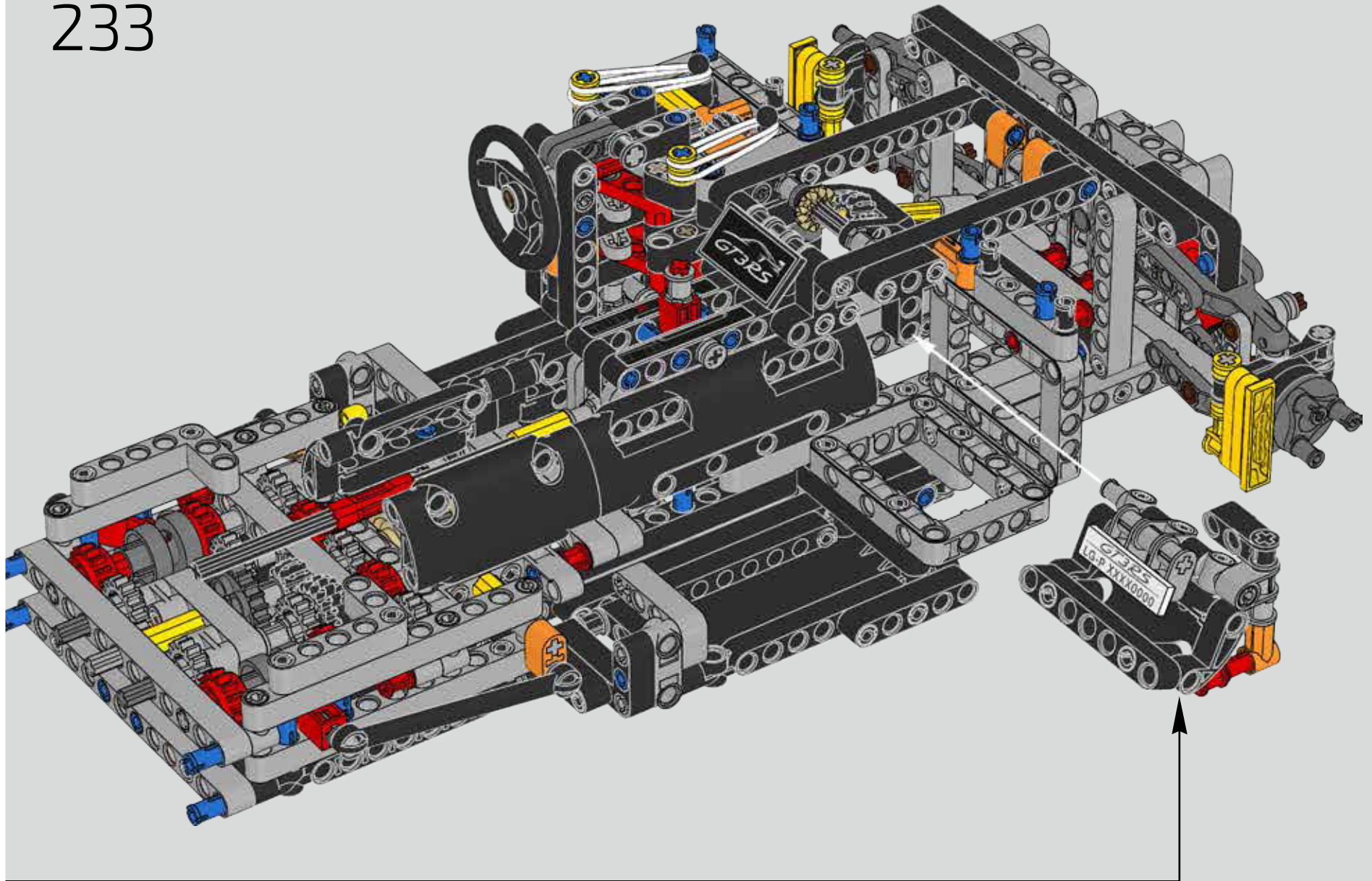

234

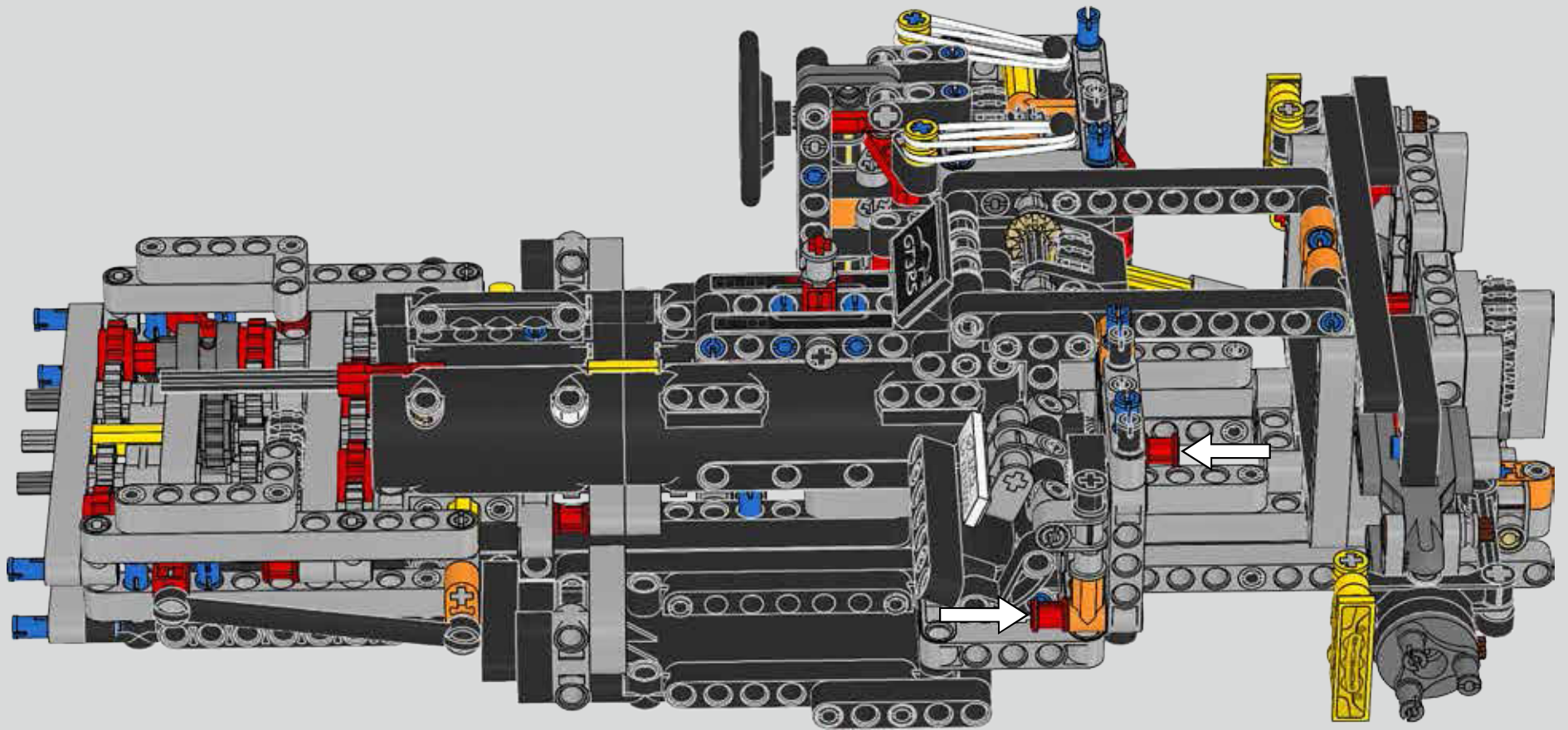

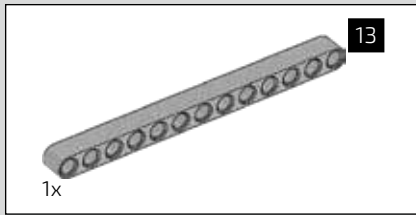

235

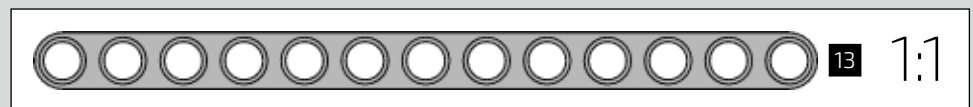
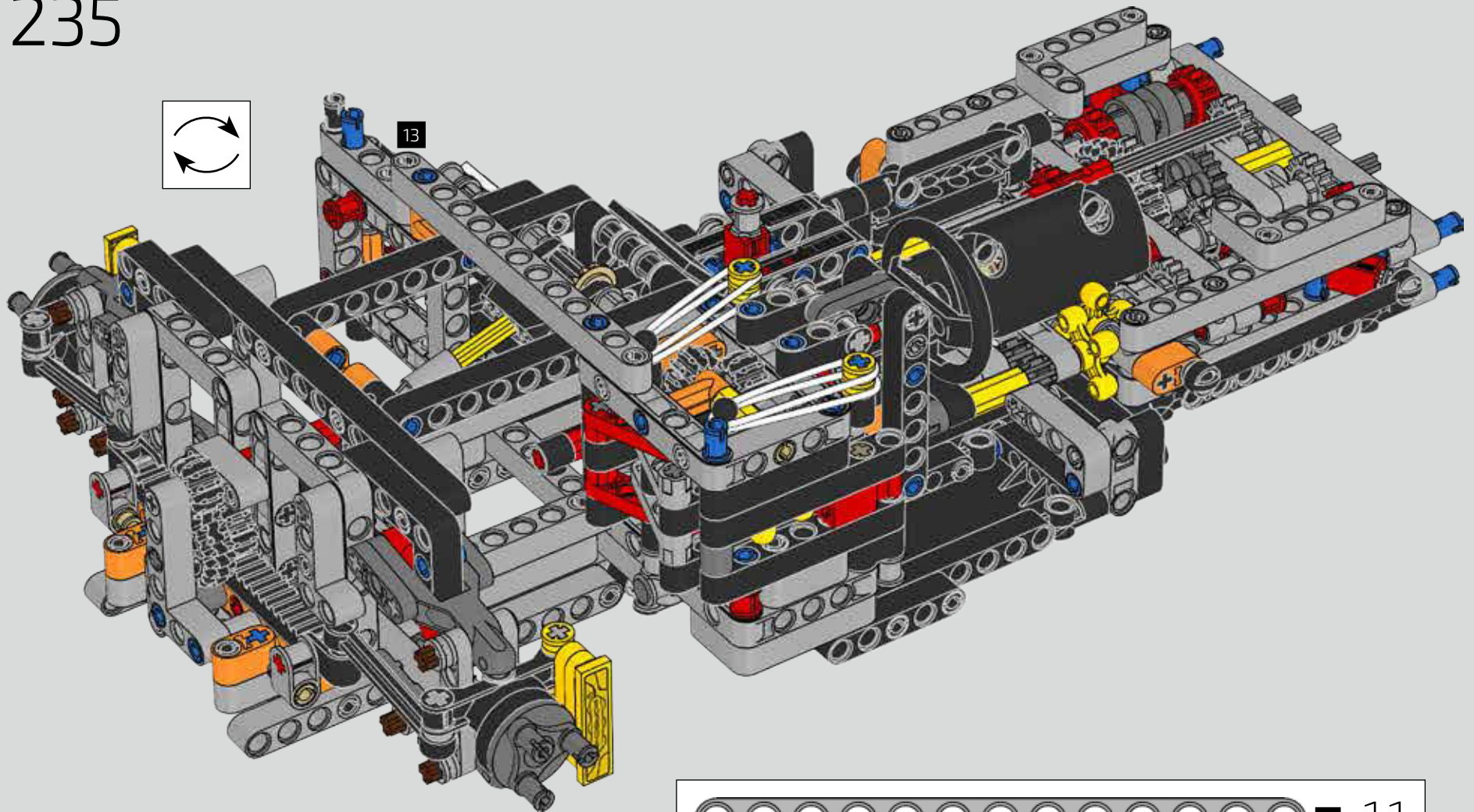
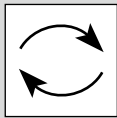

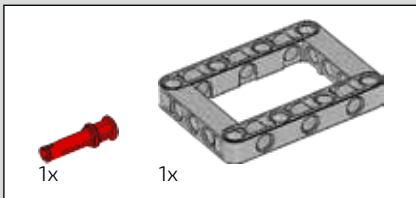
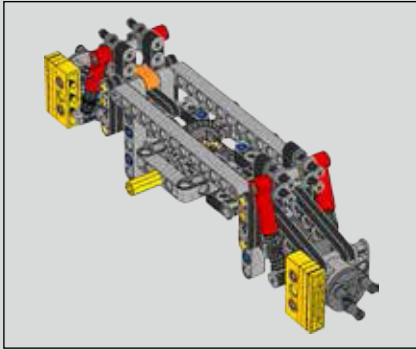

236

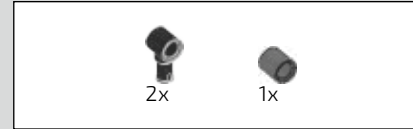
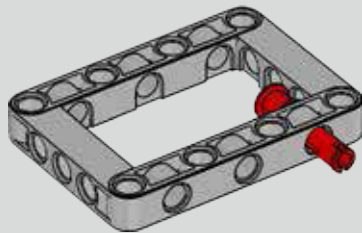

237

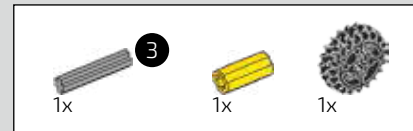
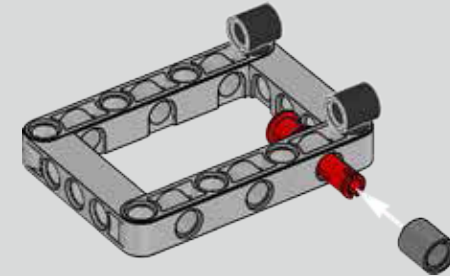

238

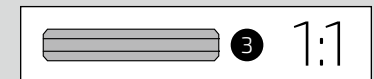
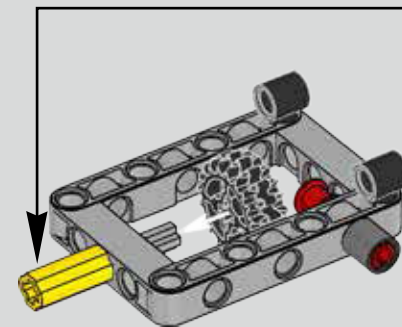
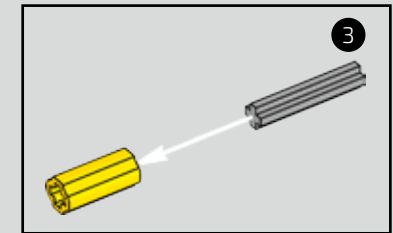

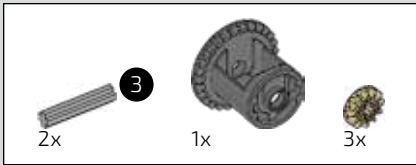

239

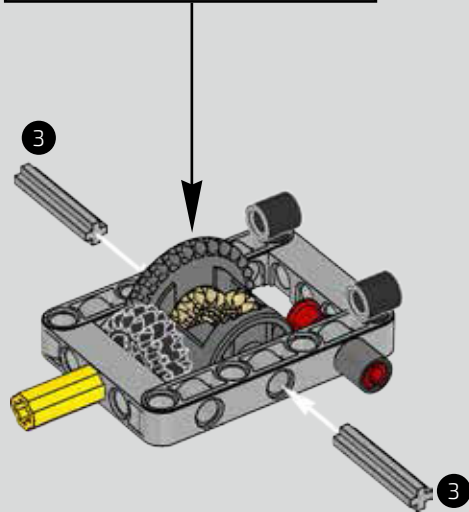
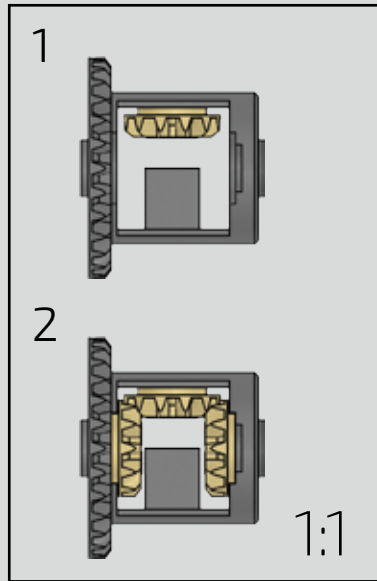

240

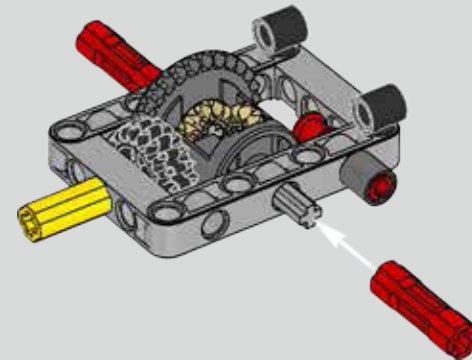

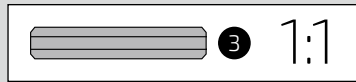

241

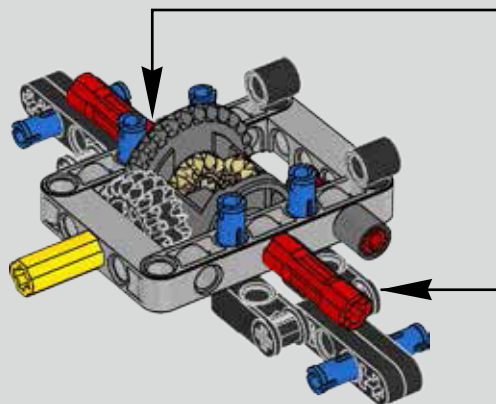
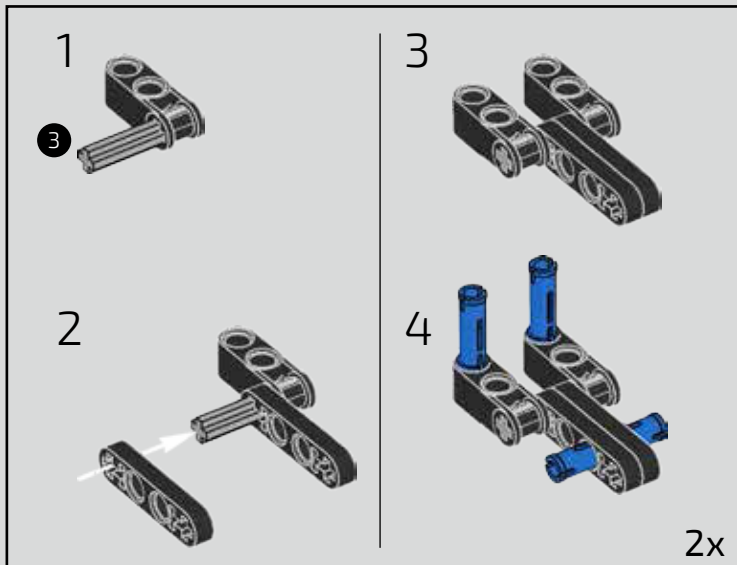

242

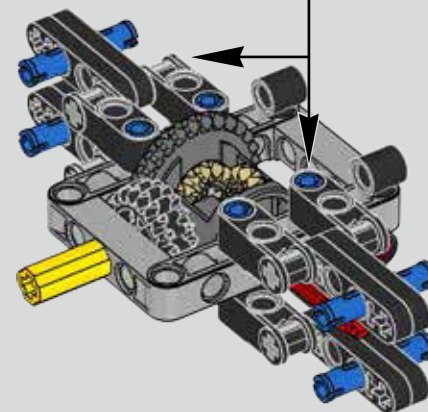
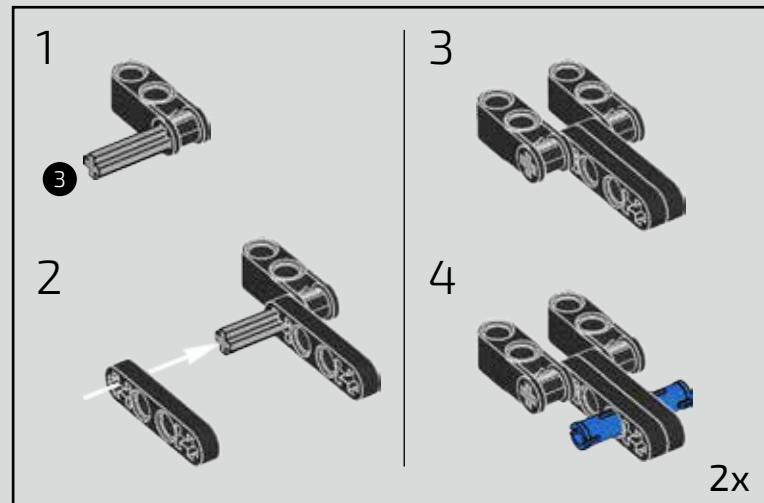

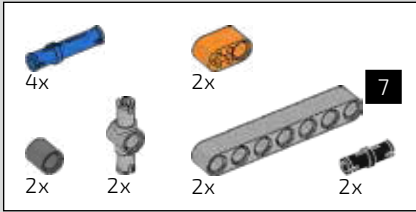

243

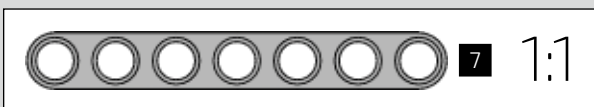
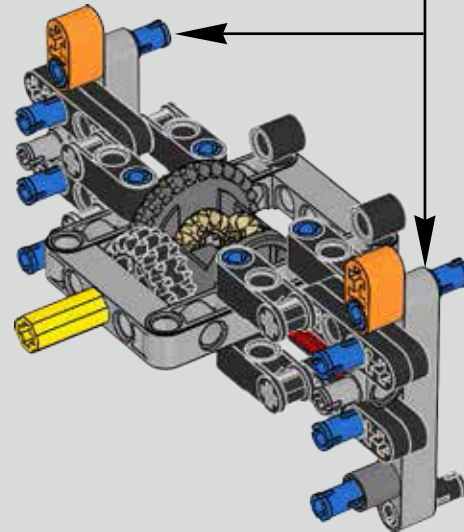
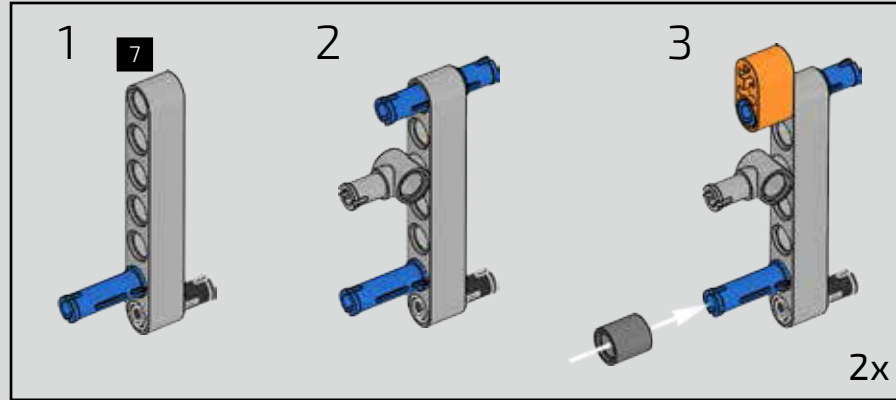

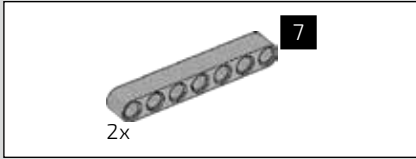

244

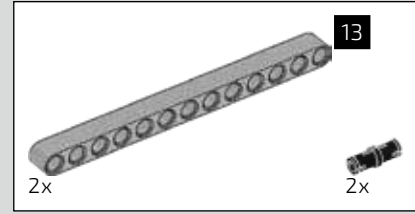
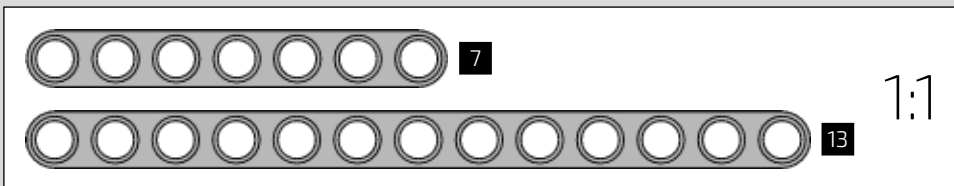
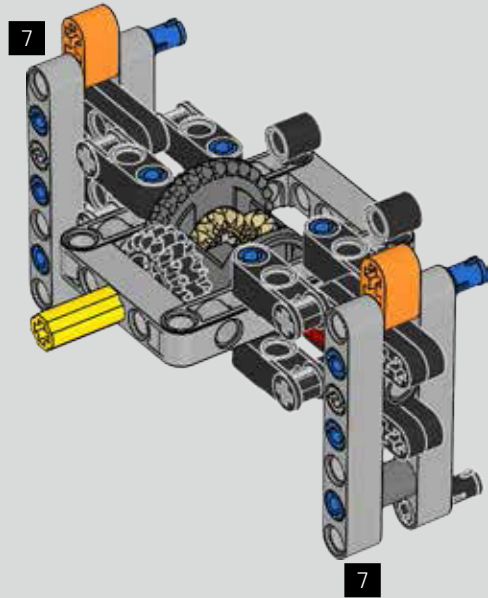

245

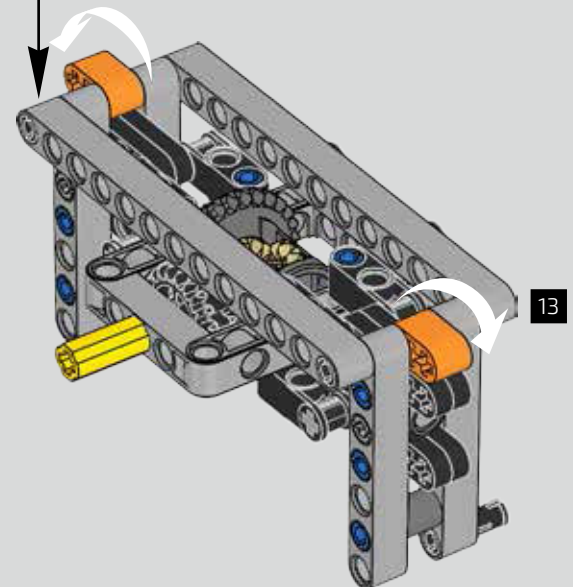
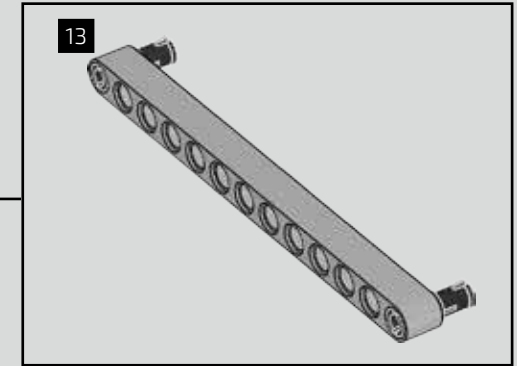

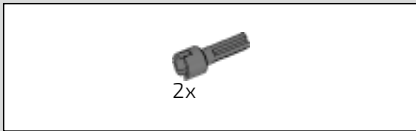

246

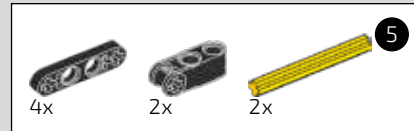
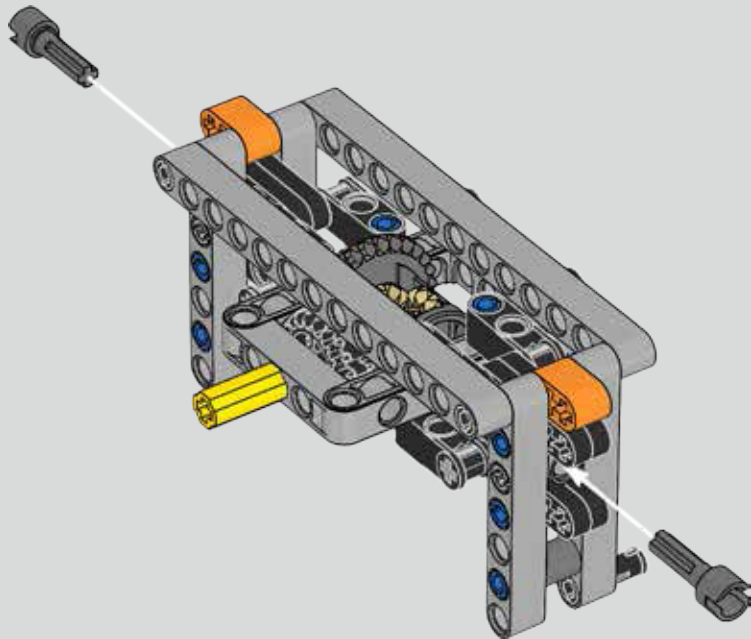

247

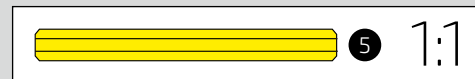
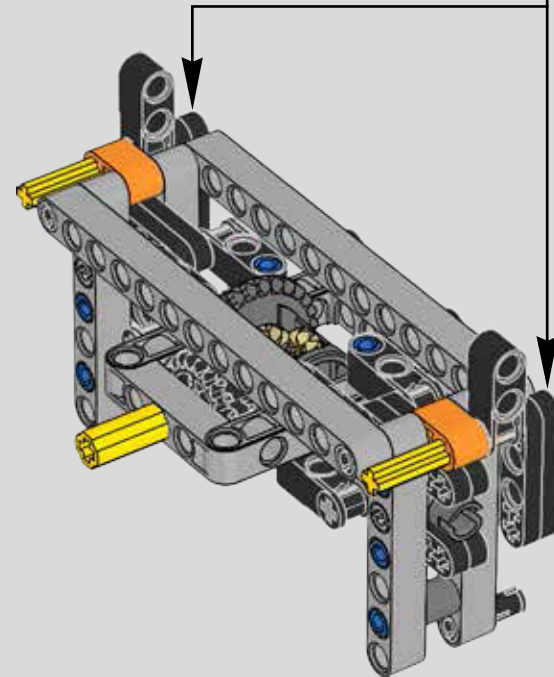
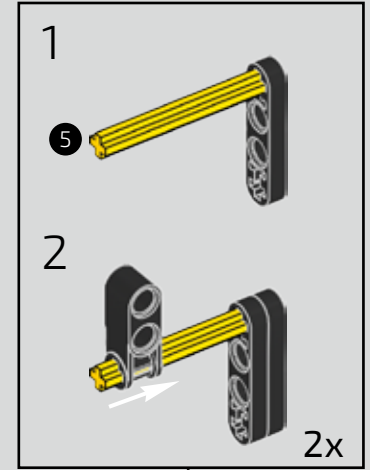

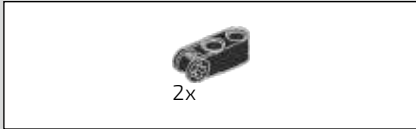

248

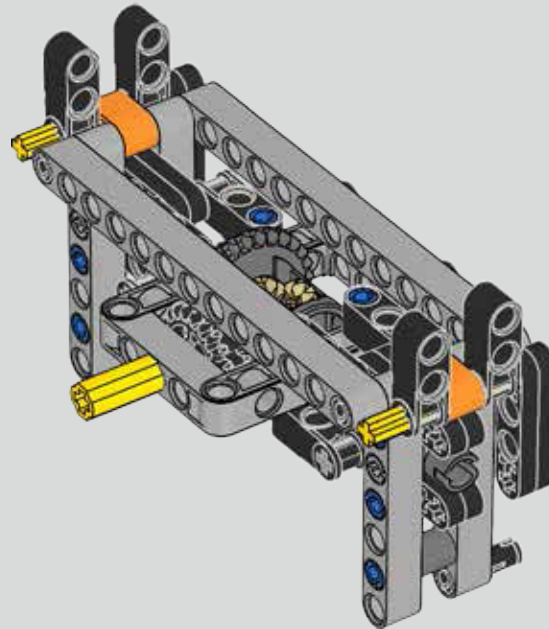

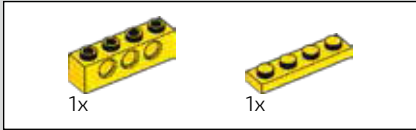
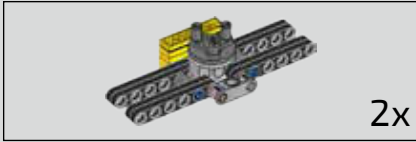

249

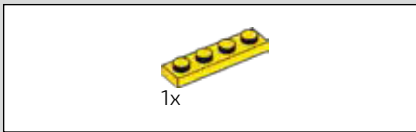
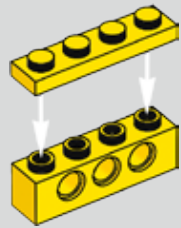

250

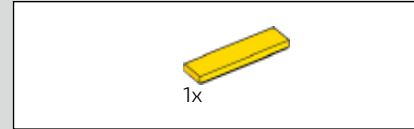
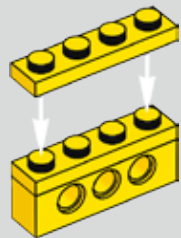

251

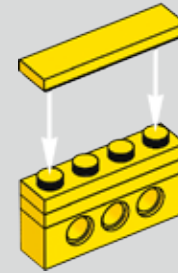

252

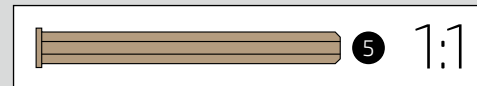
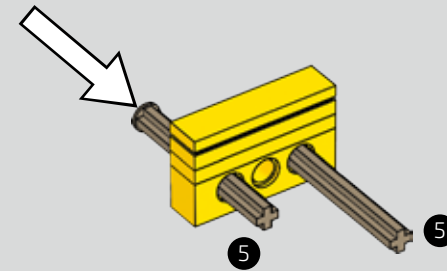

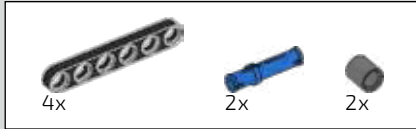

253

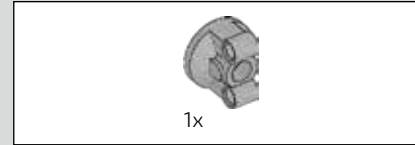
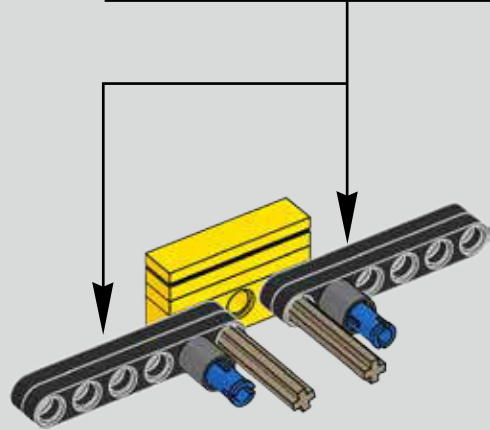
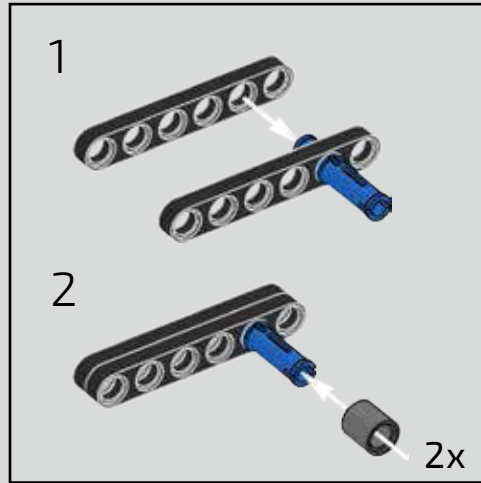

254

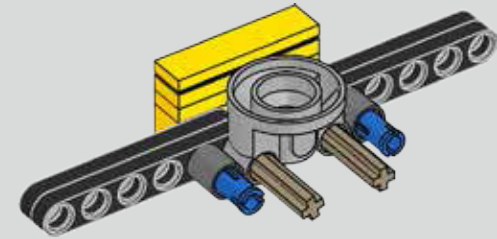

255

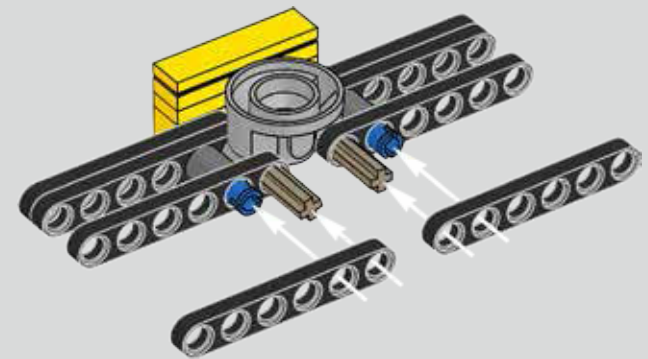

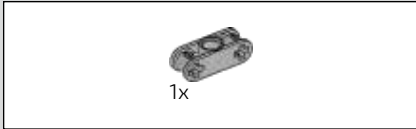

256

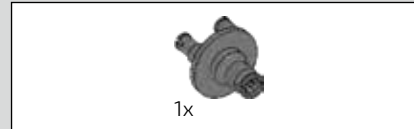
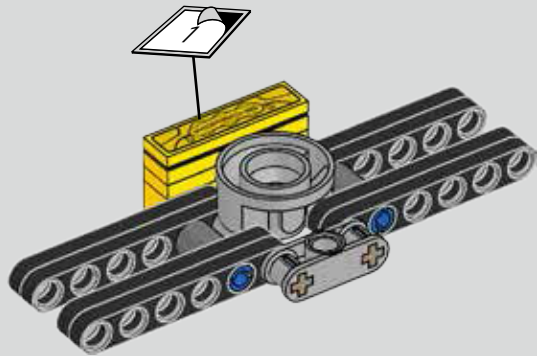

257

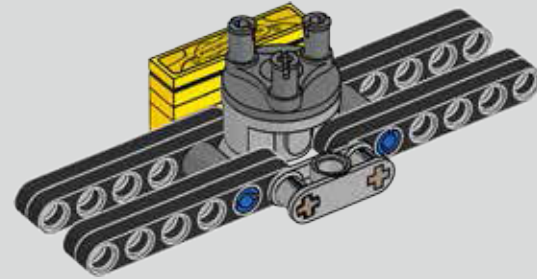

258

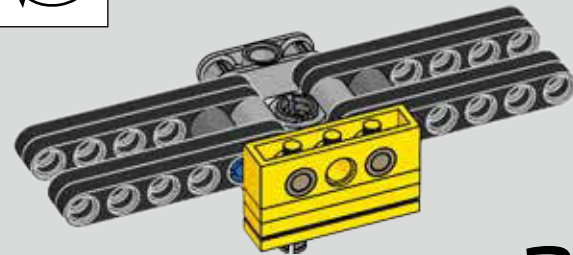
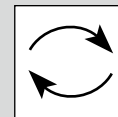

2x

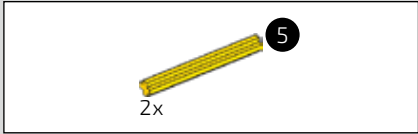

259

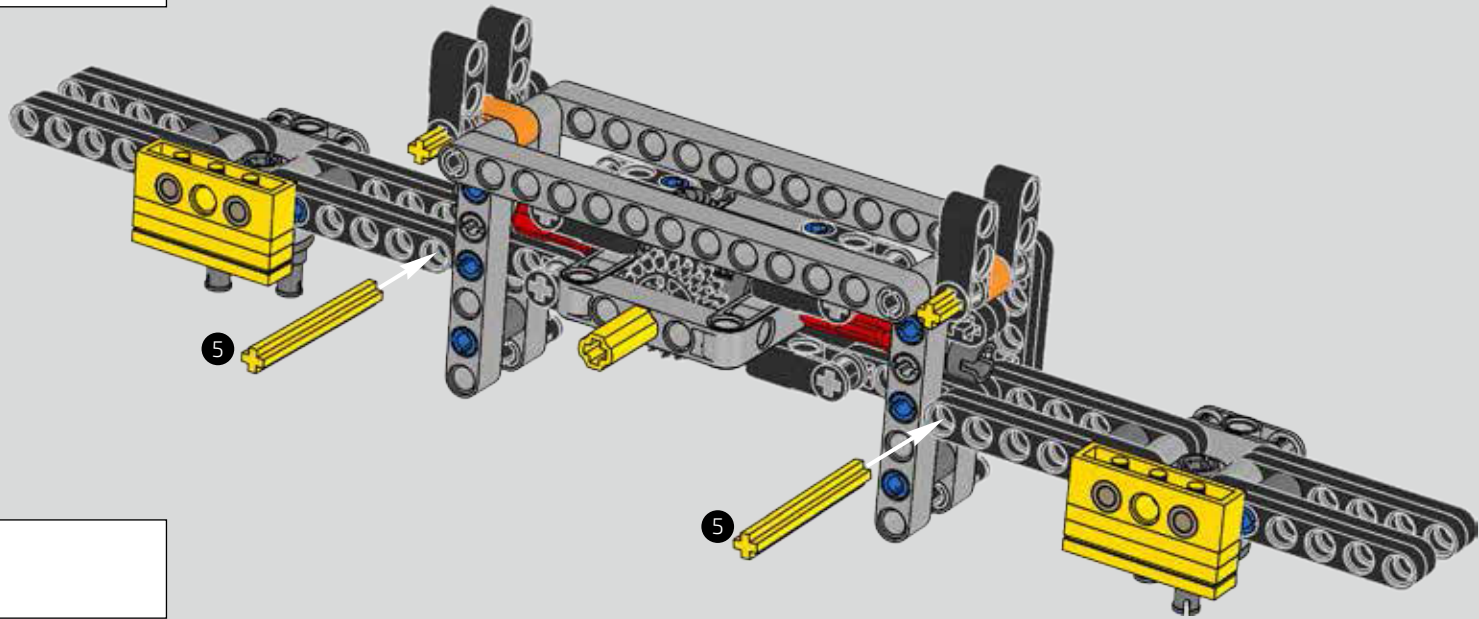

260

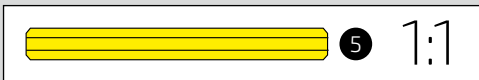
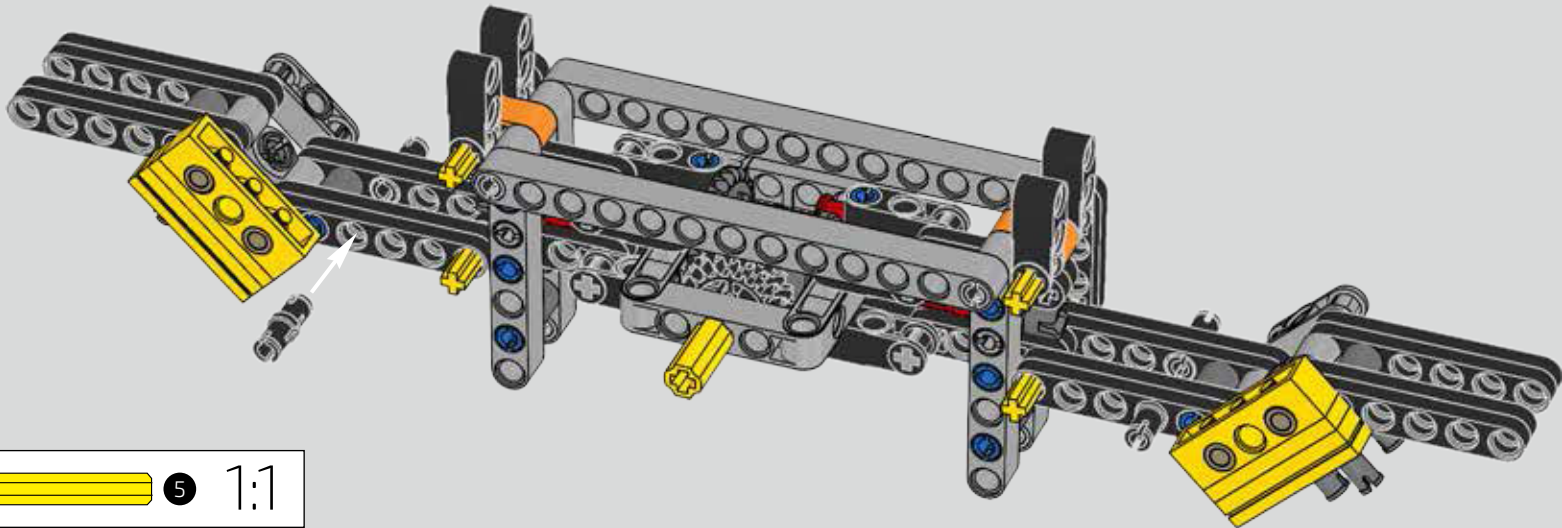

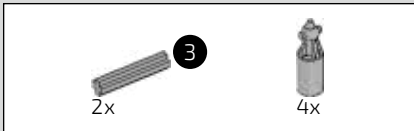

261

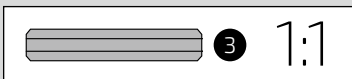
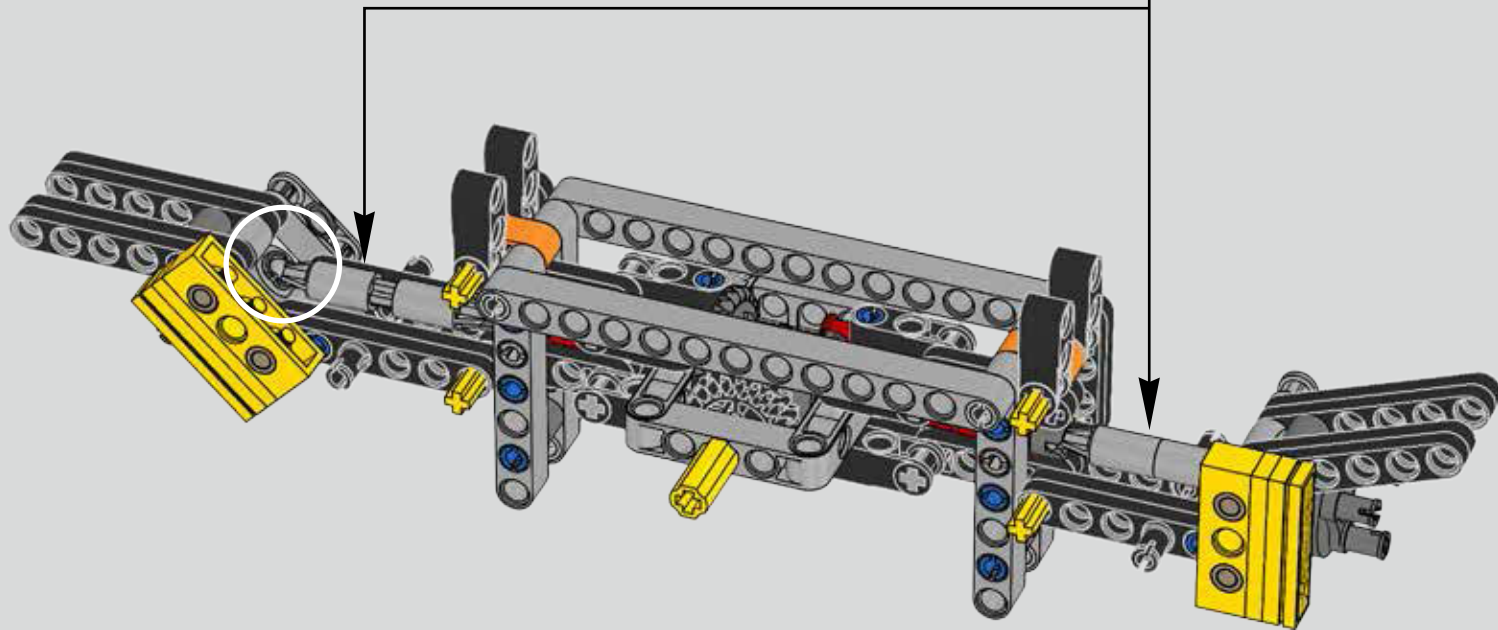
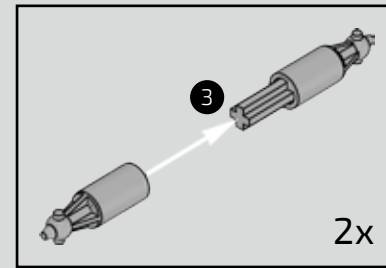

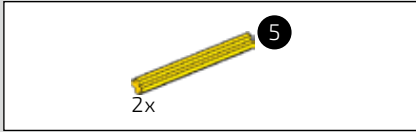

262

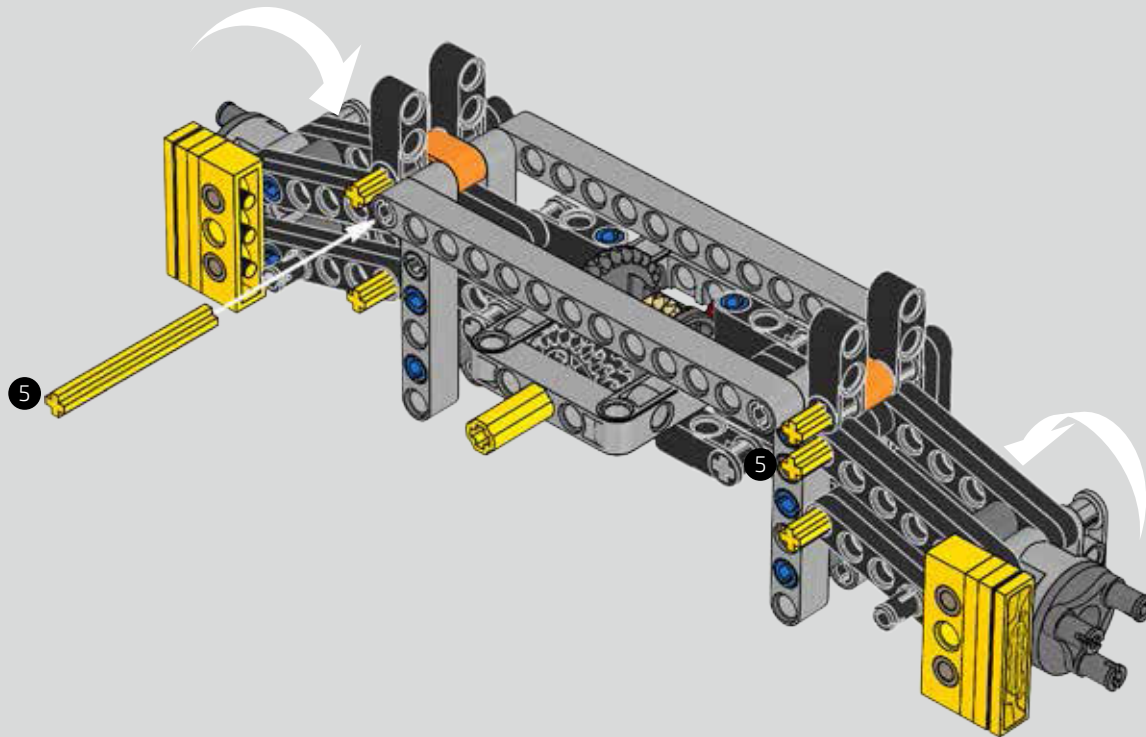

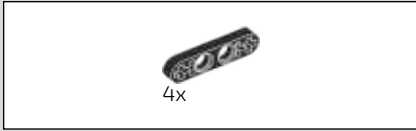

263

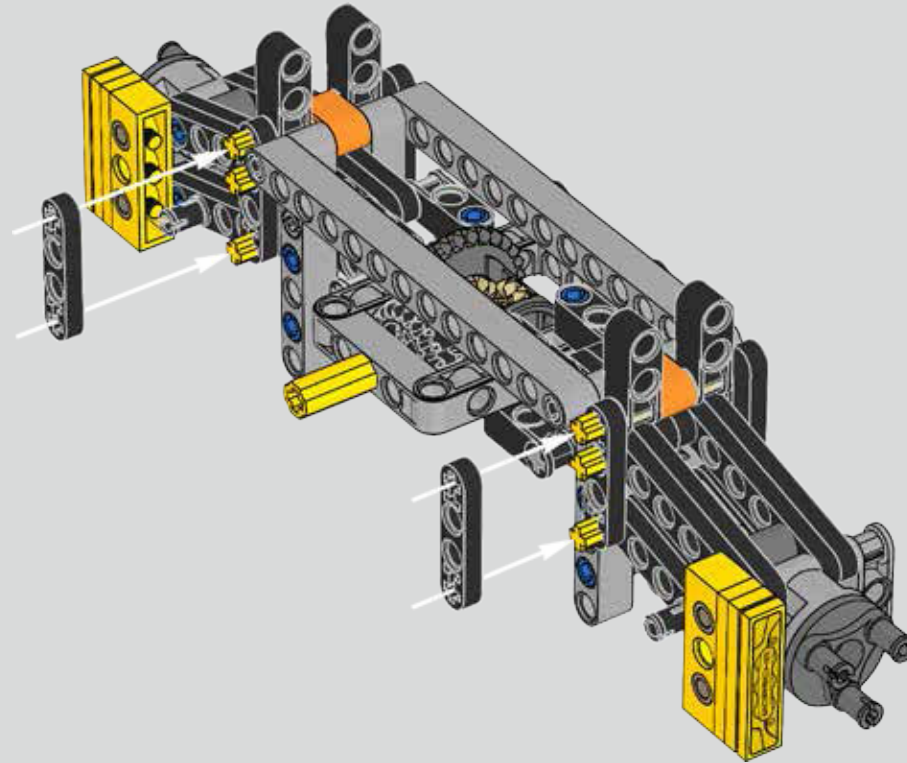

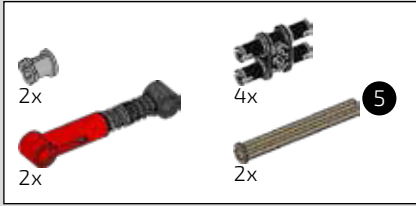

264

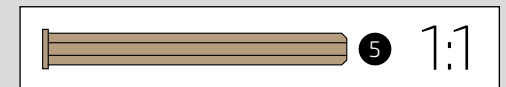
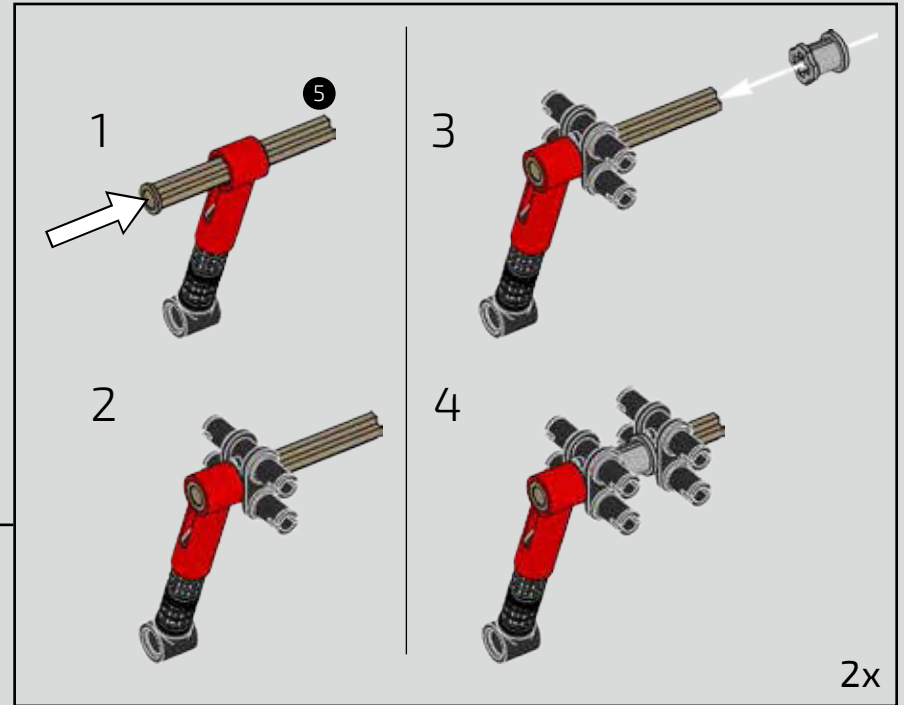
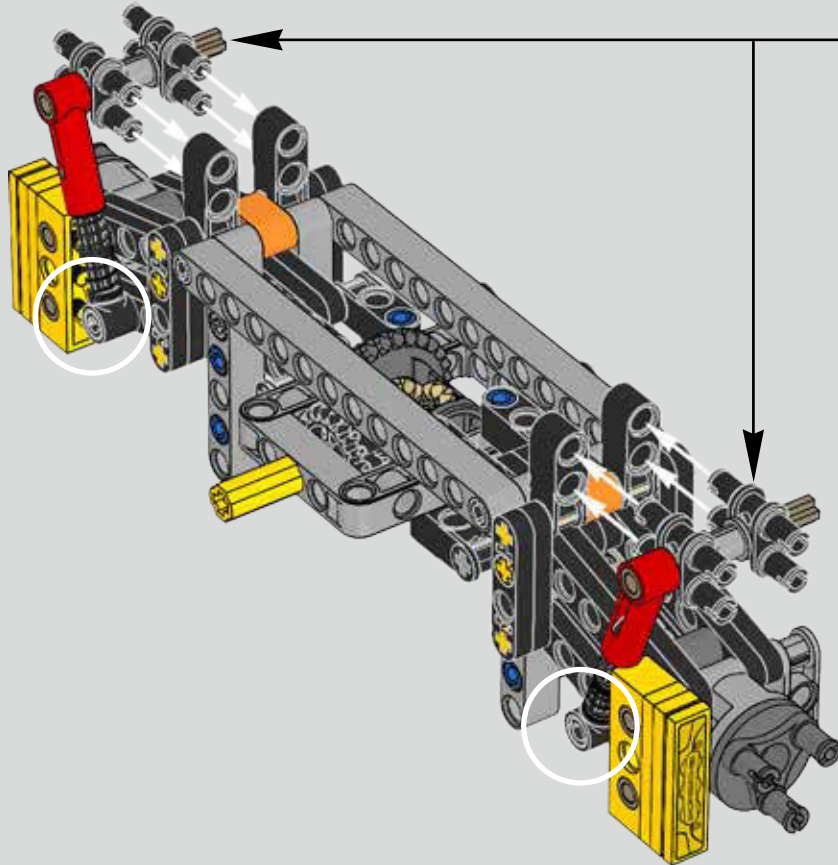

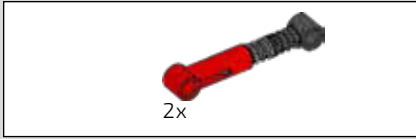

265

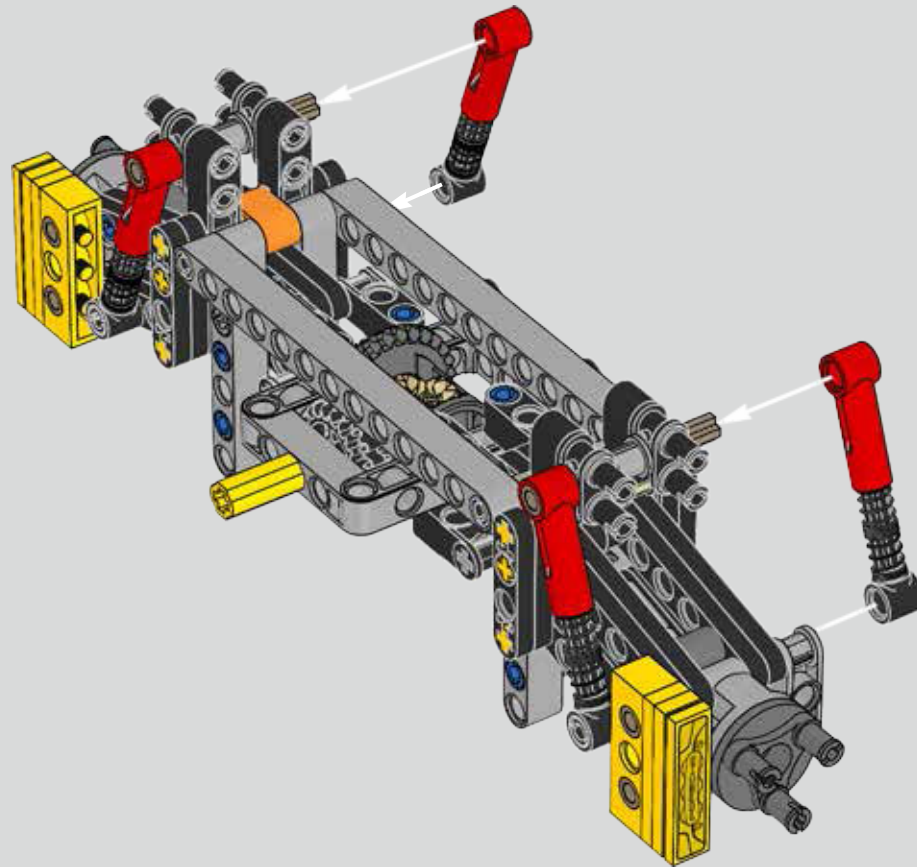

266

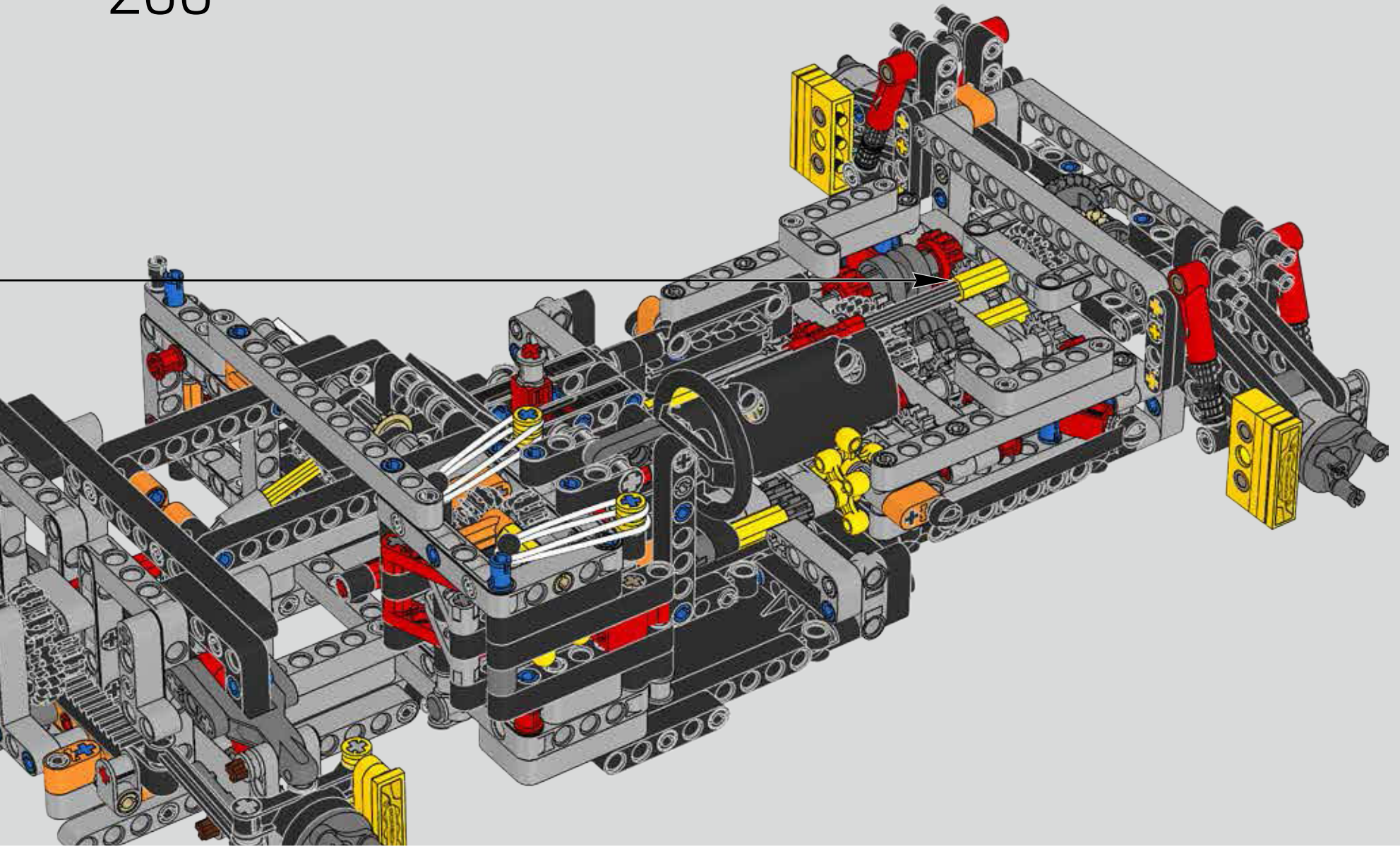

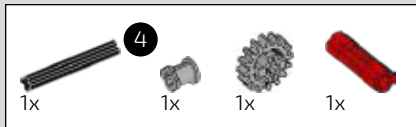

267

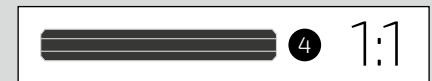
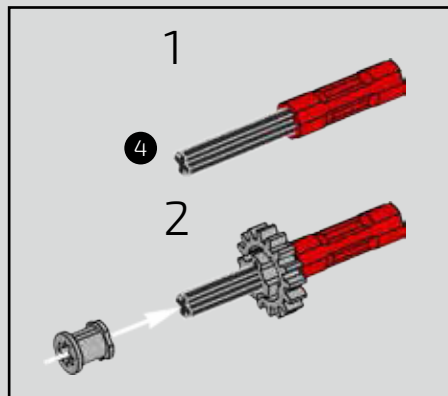
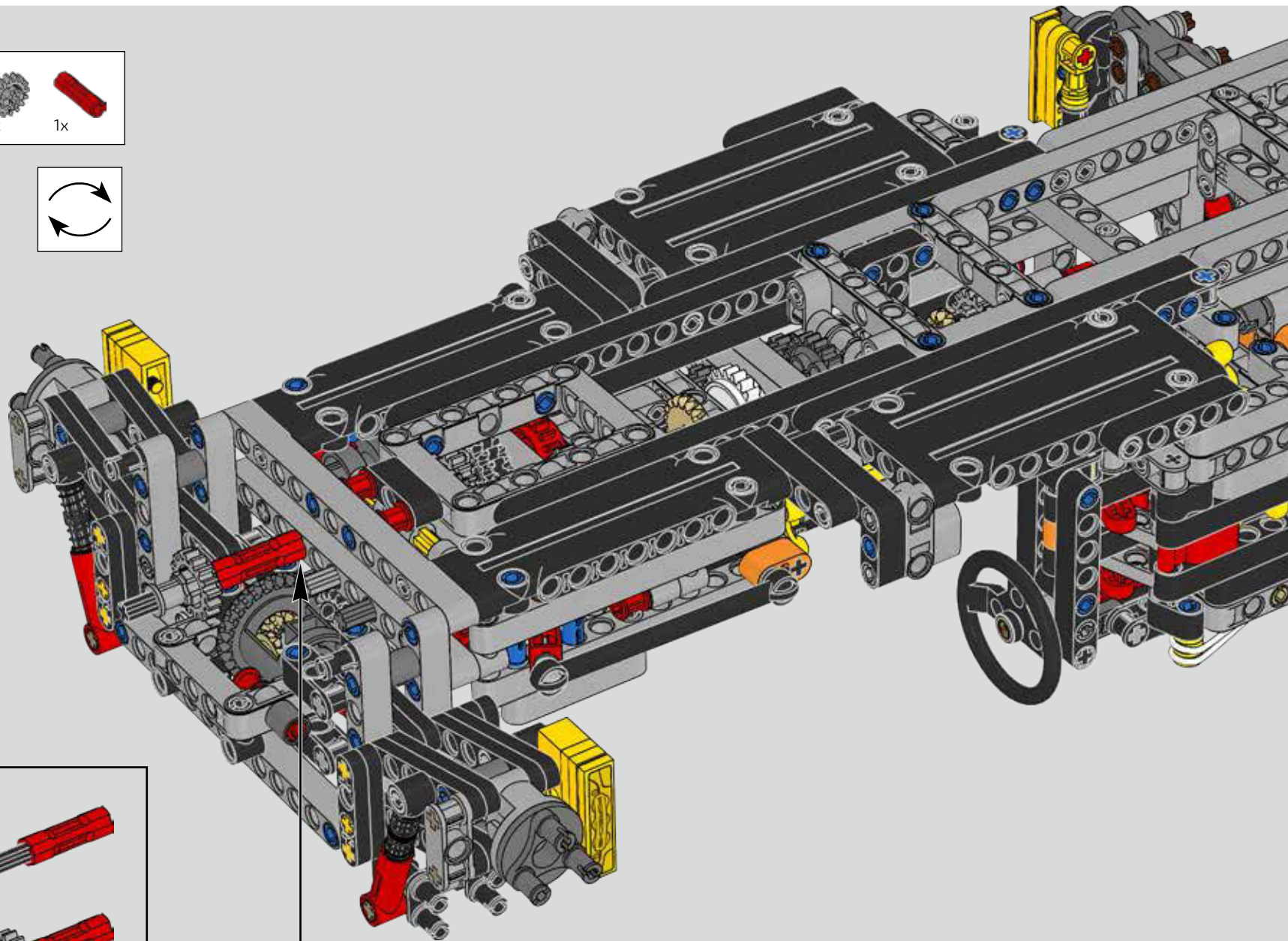
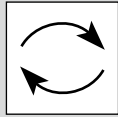

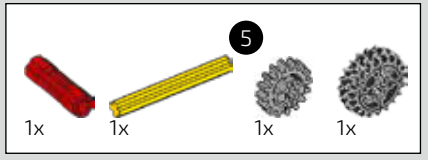

268

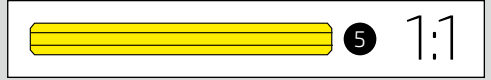
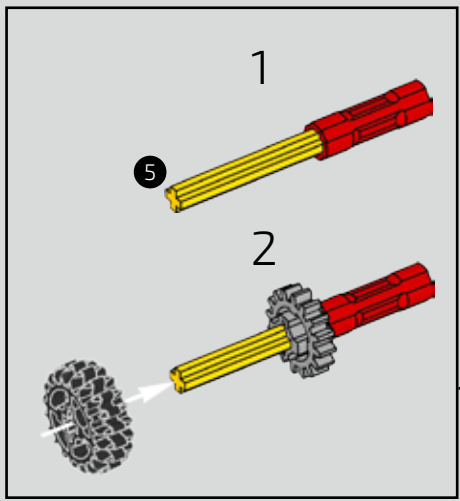
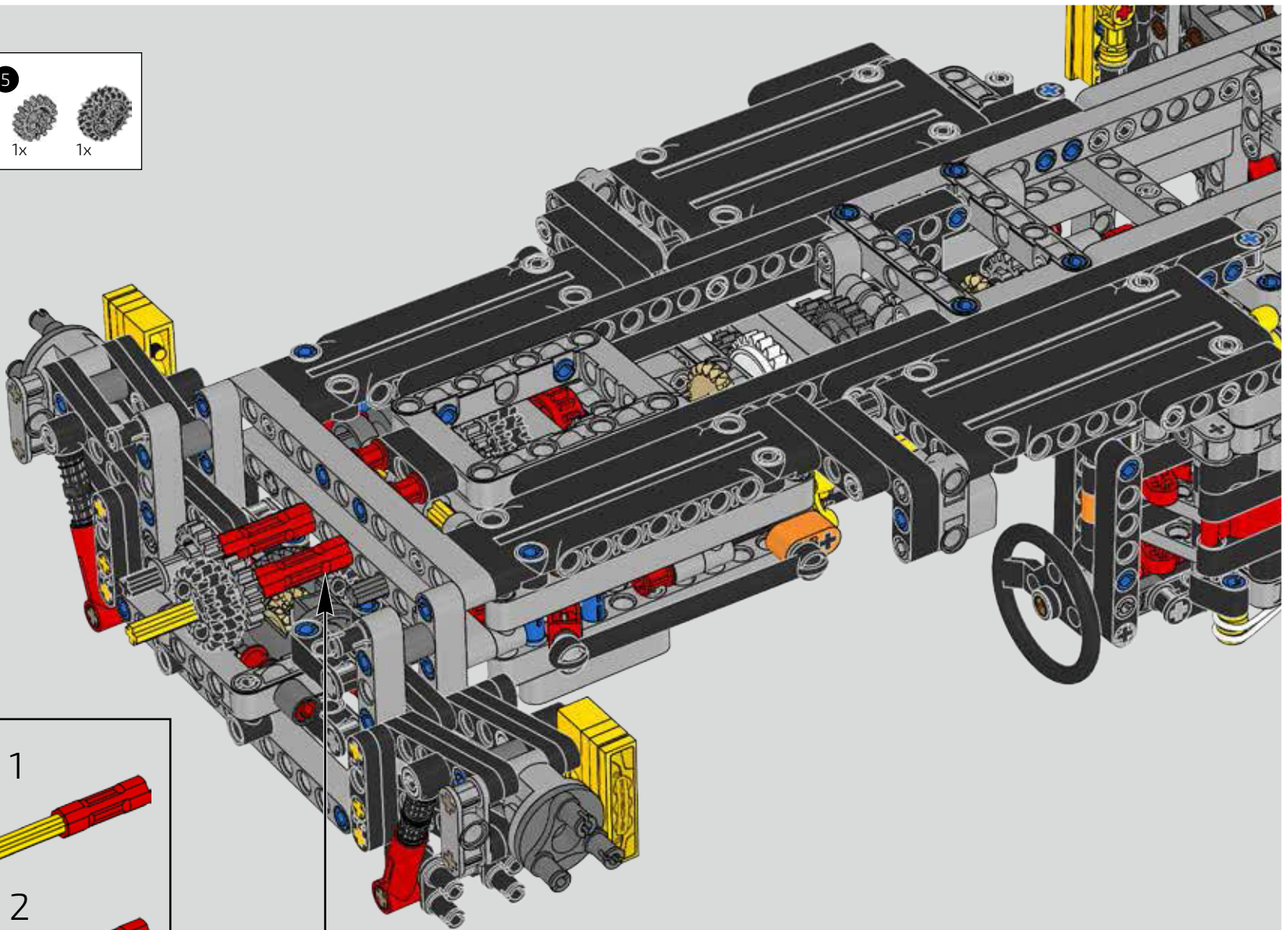

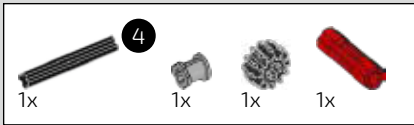

269

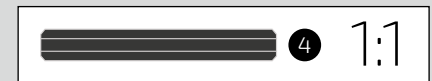
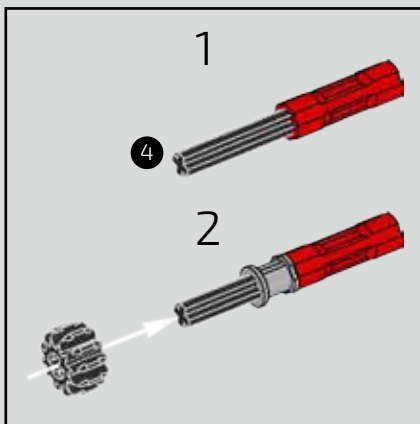
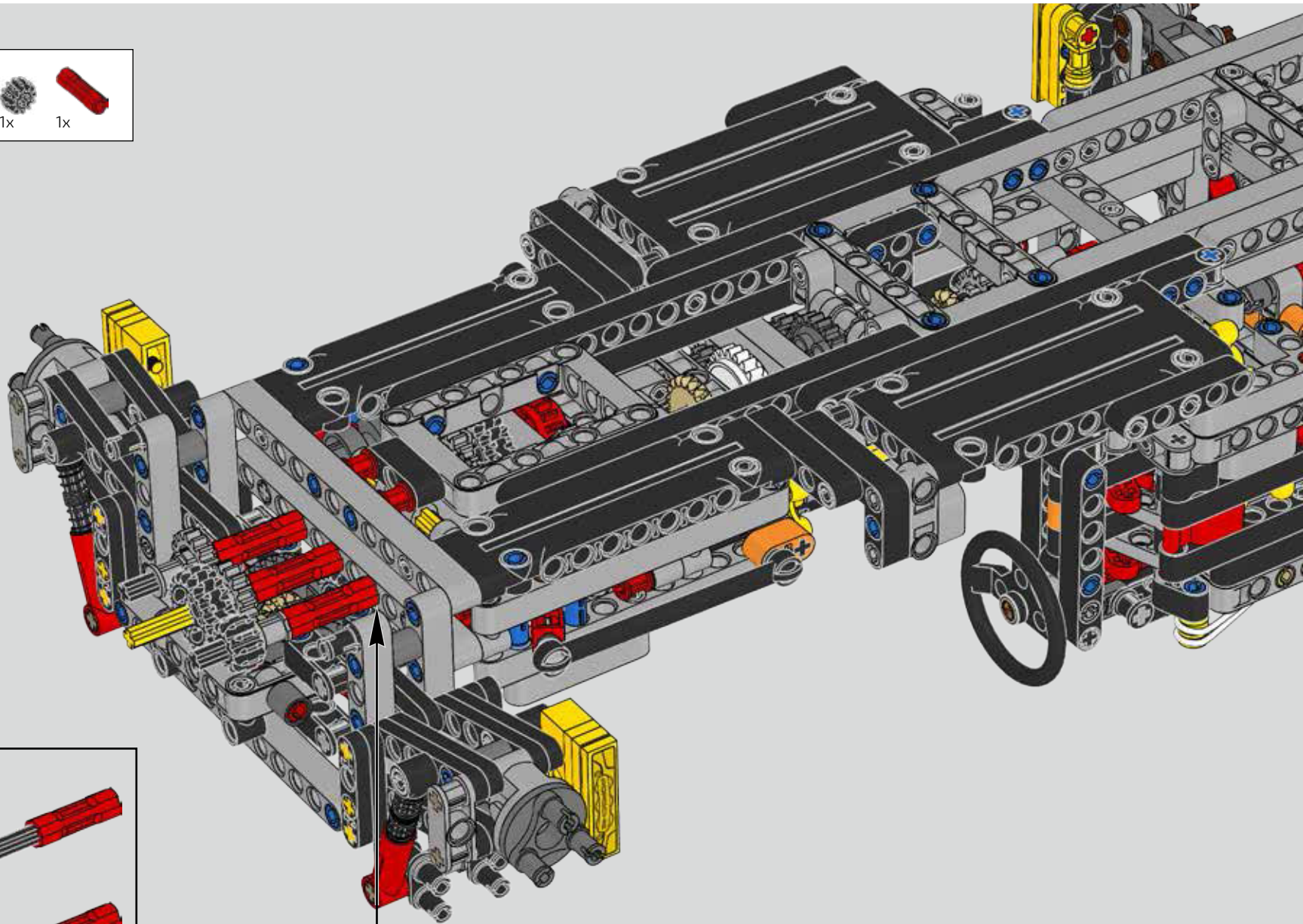

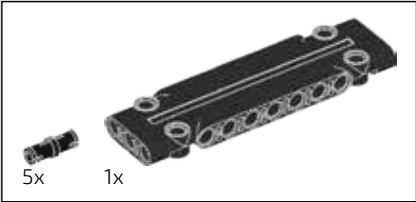

270

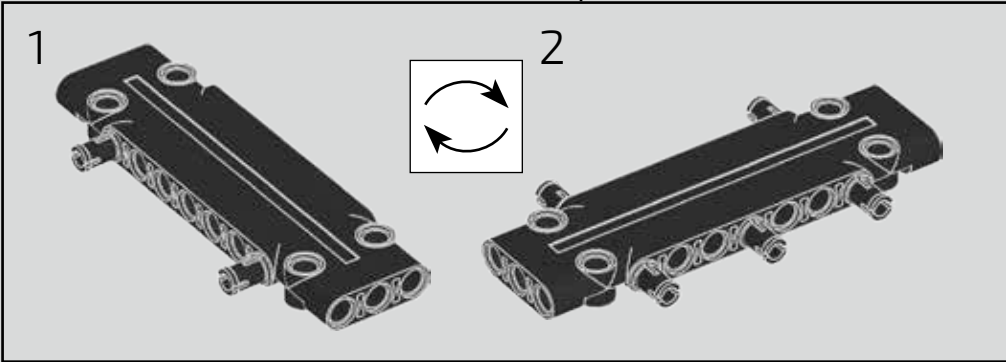
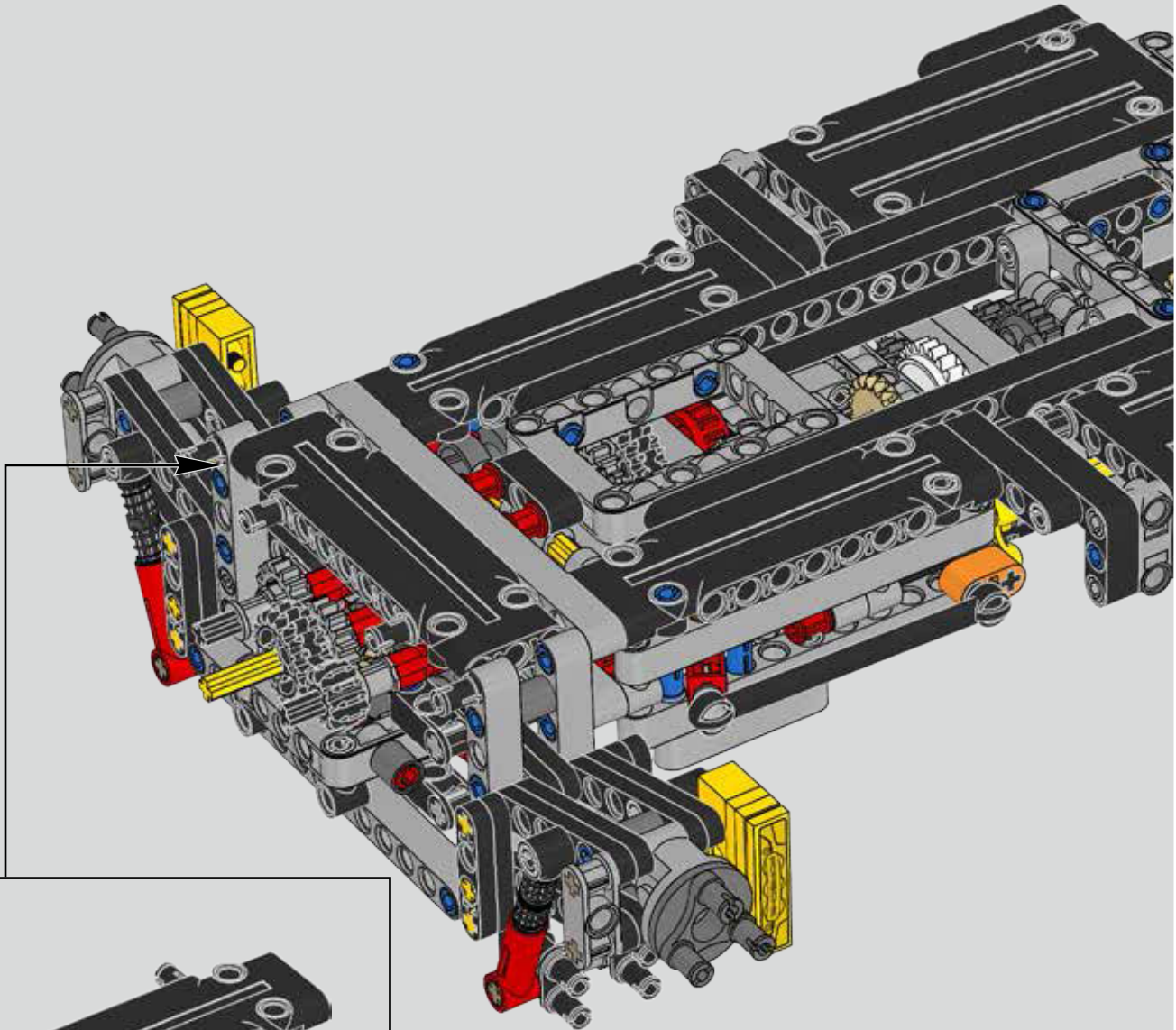

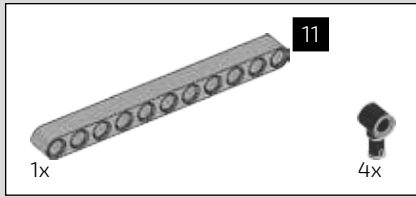

271

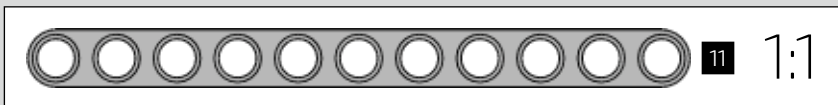
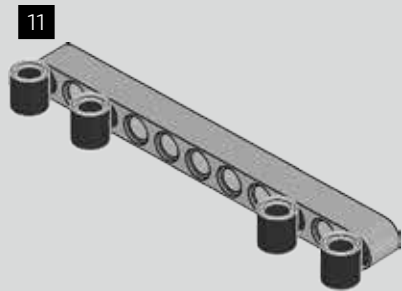

272

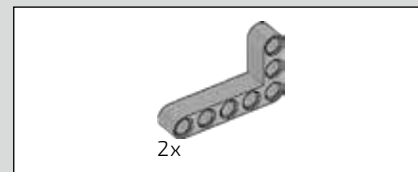
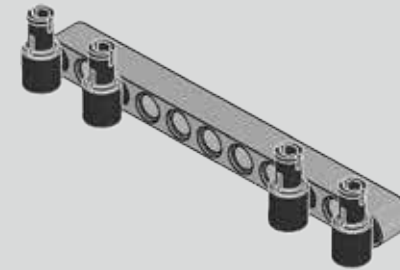

273

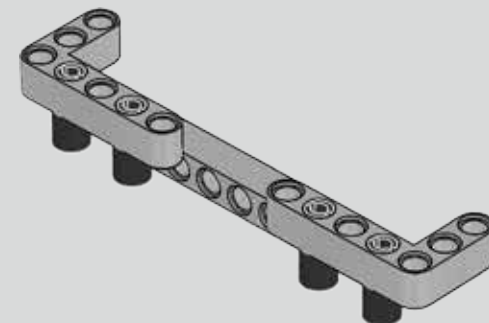

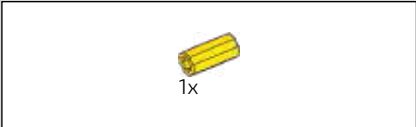

274

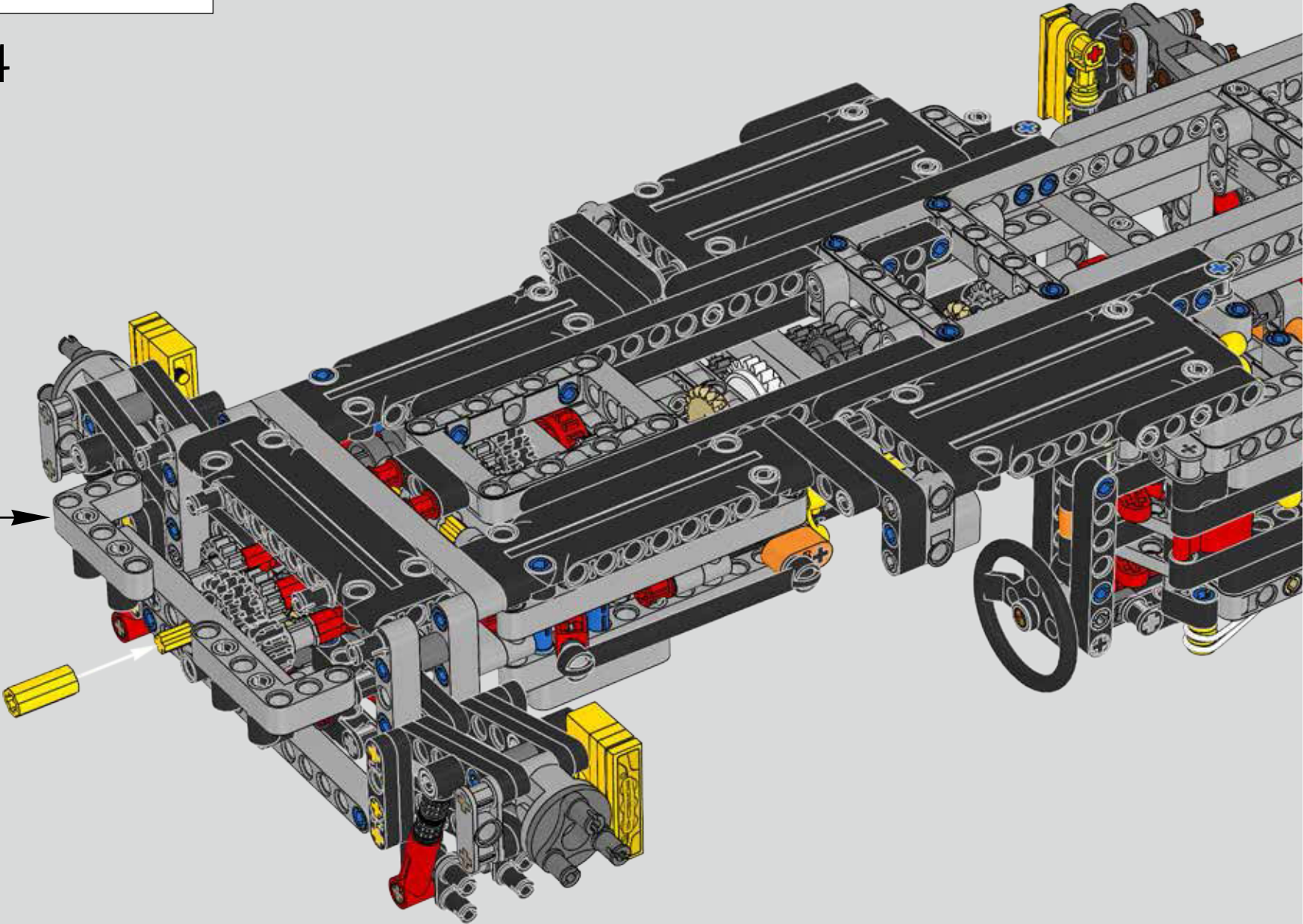

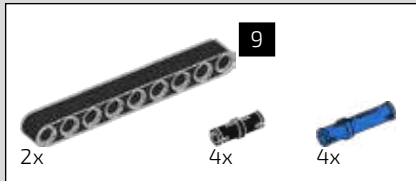

275

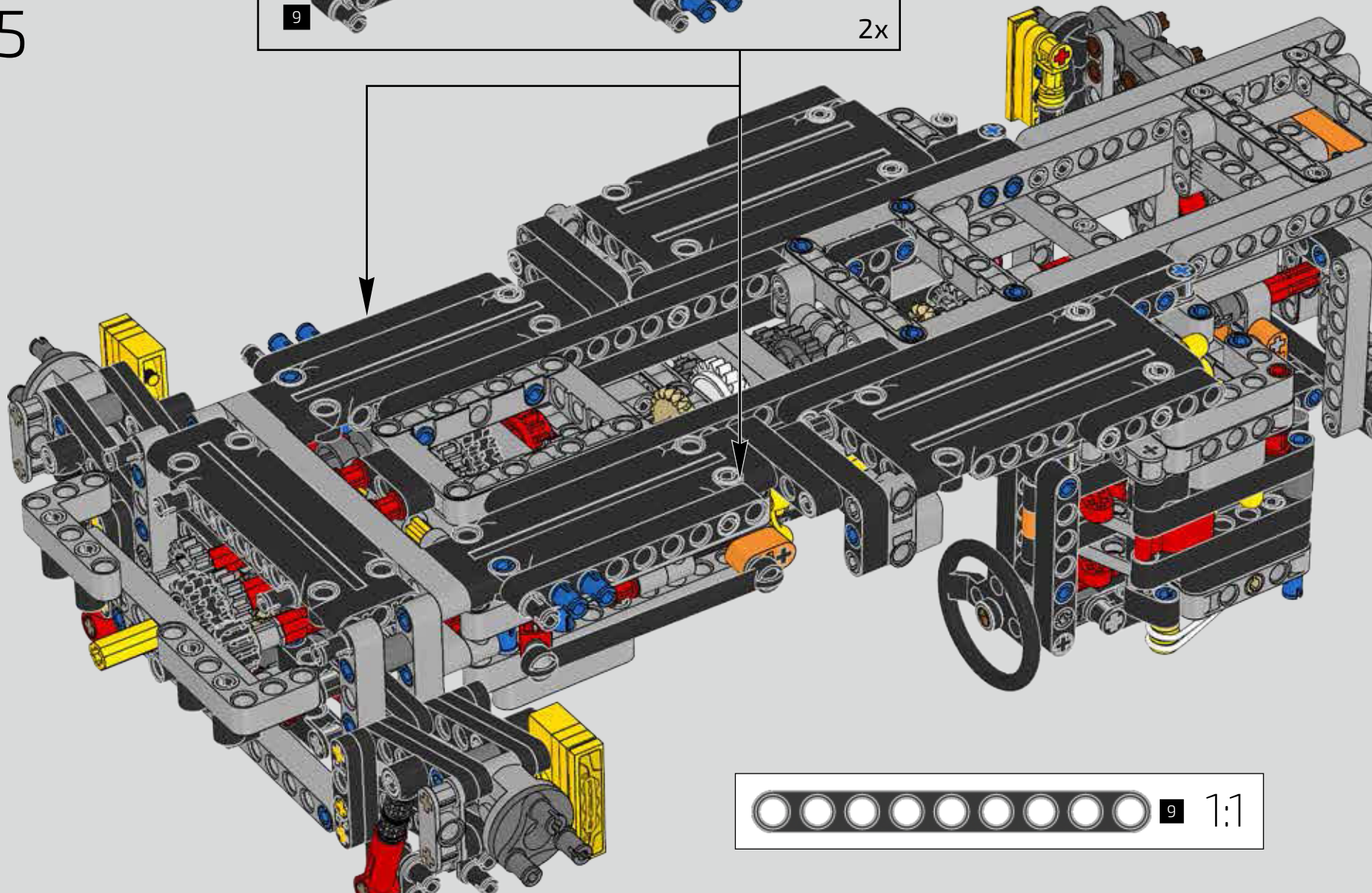
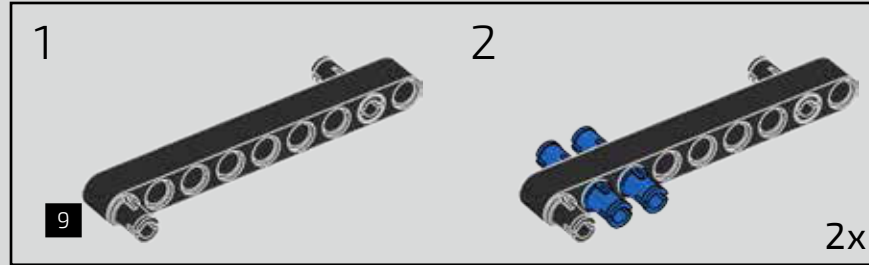

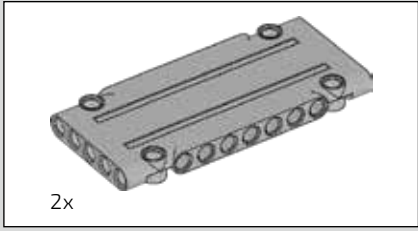

276

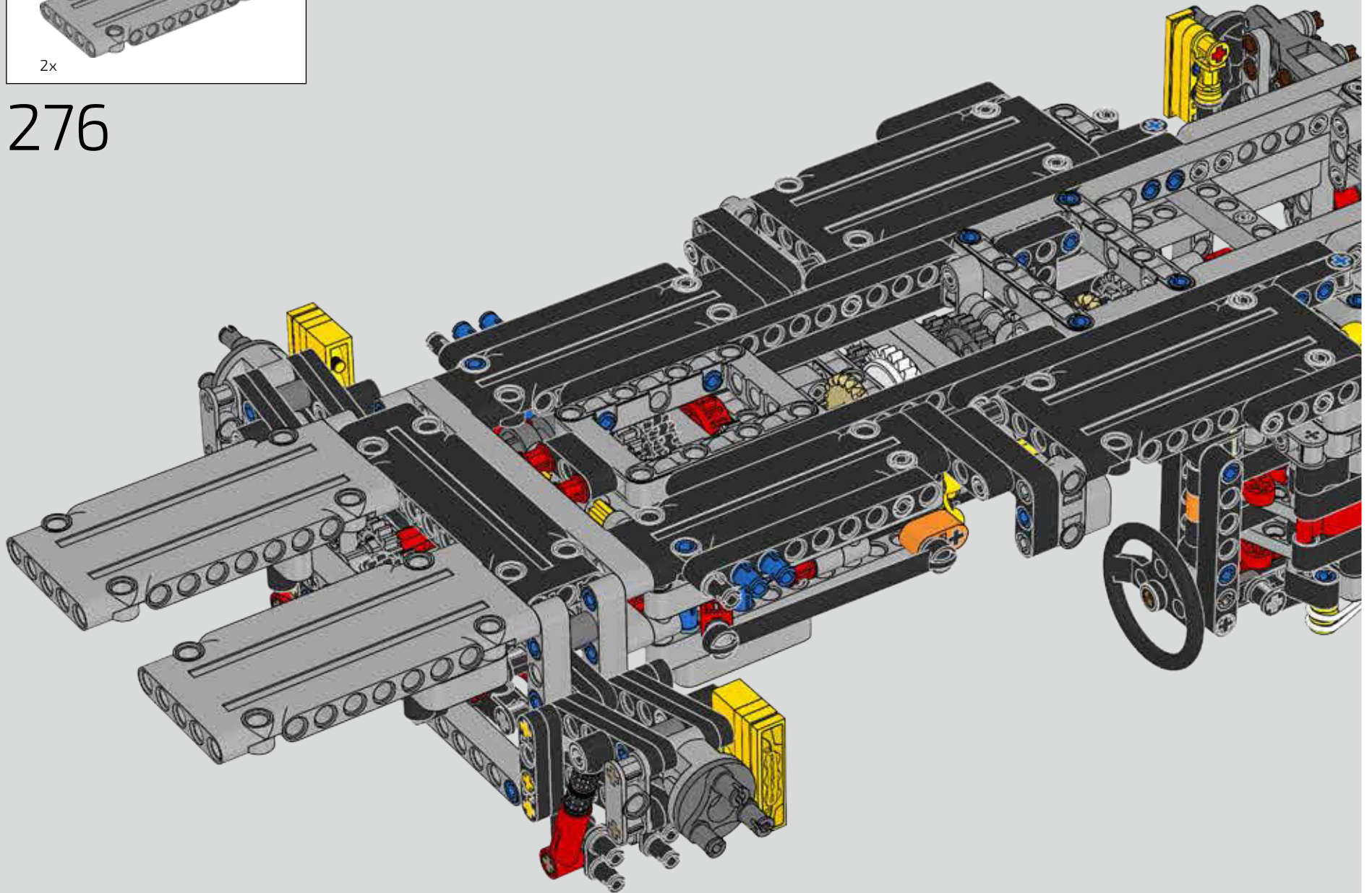

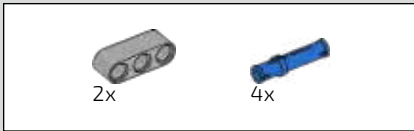

277

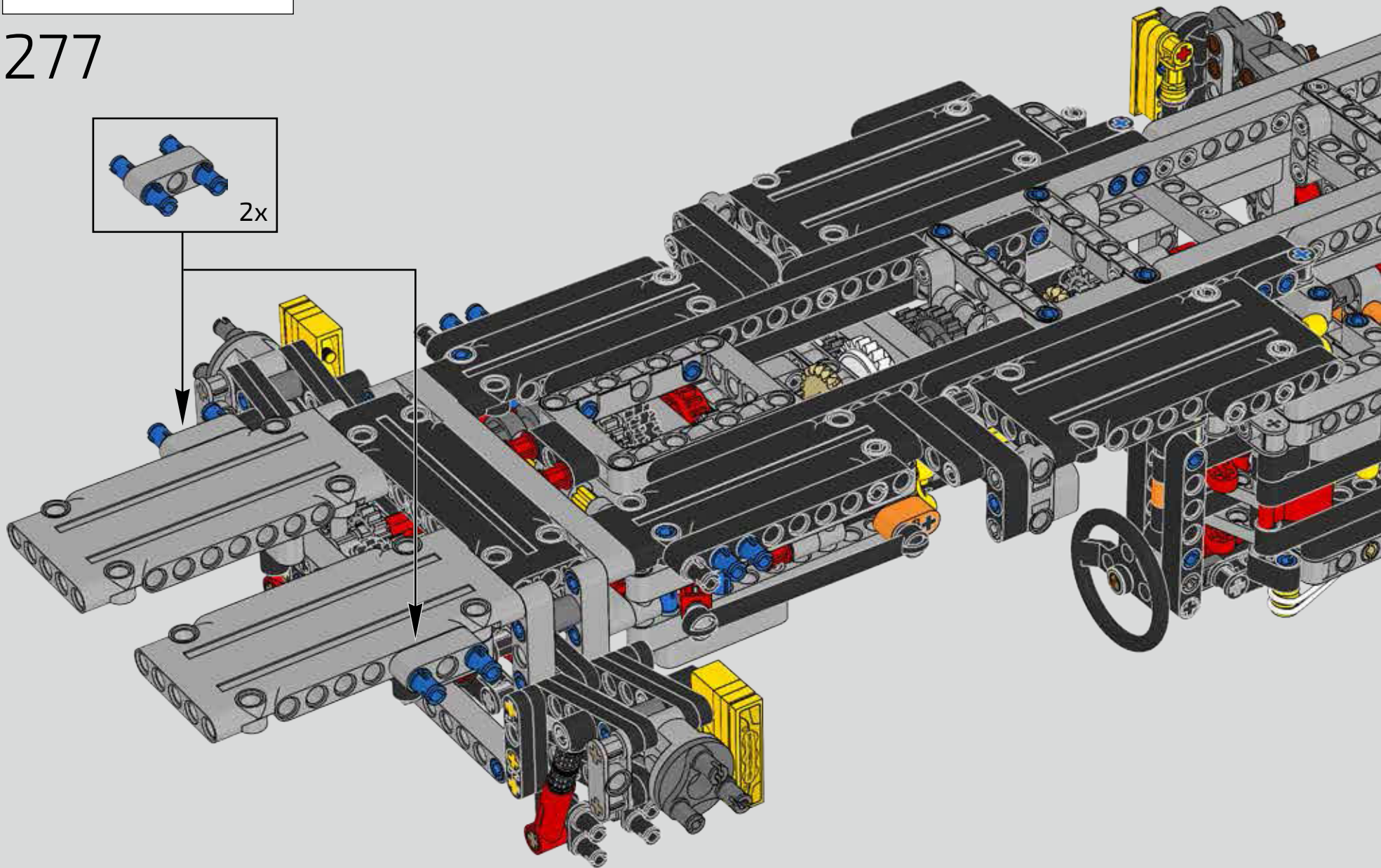
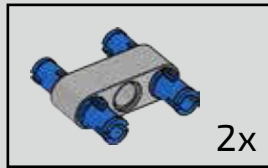



278

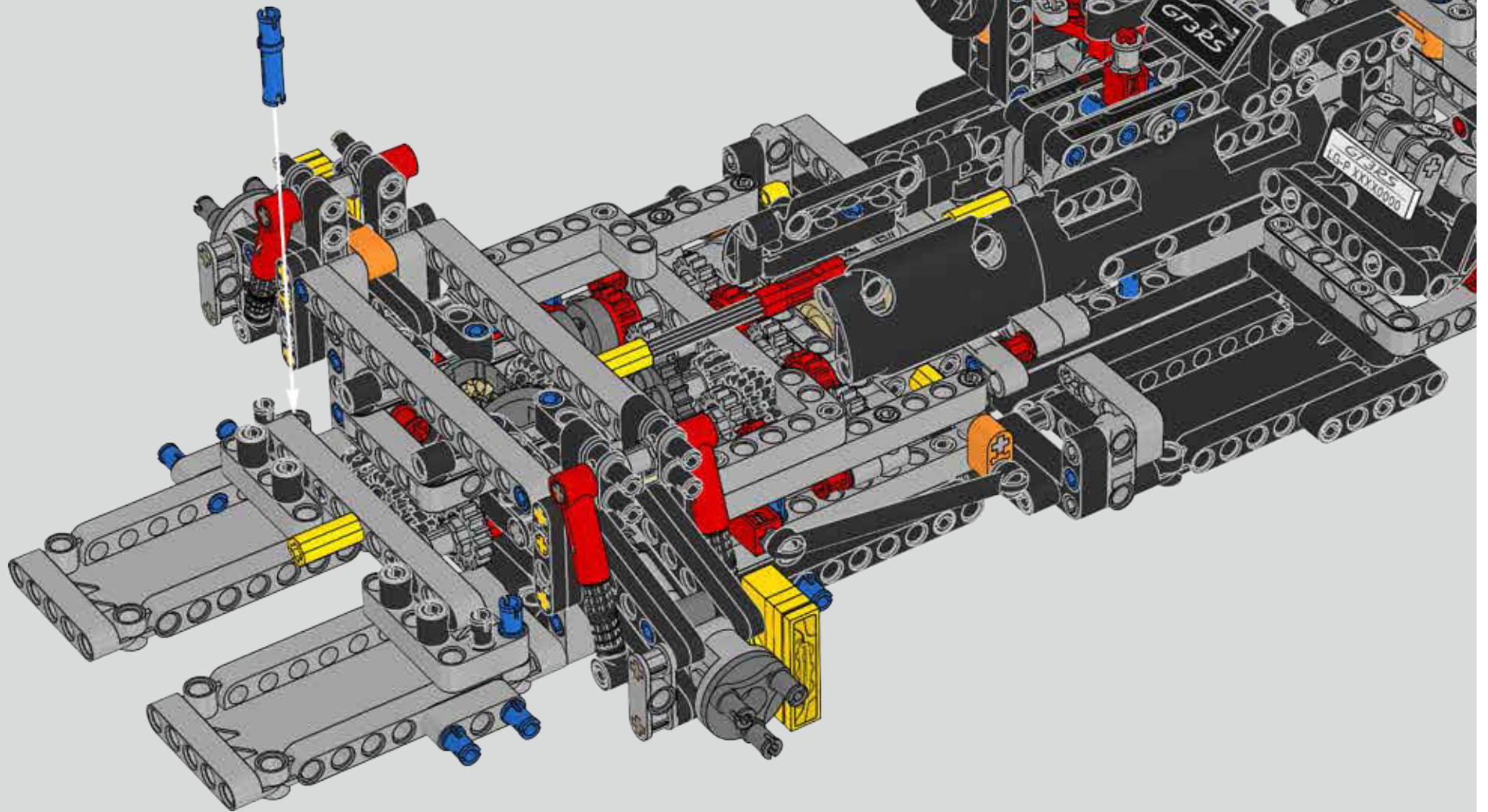
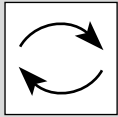

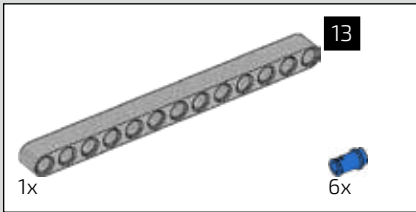
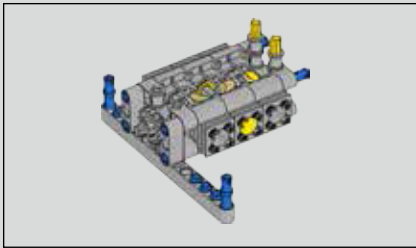

279

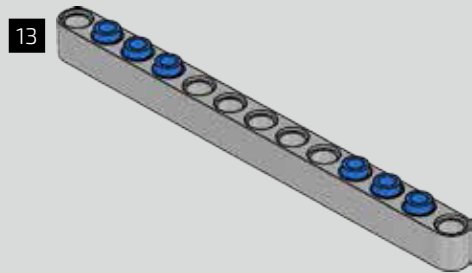

280

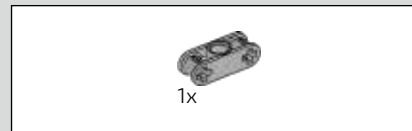
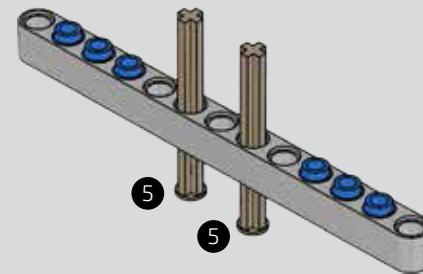

281

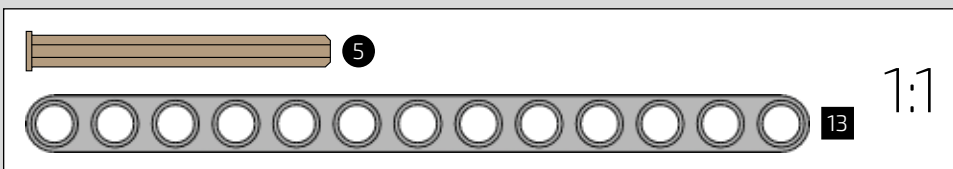
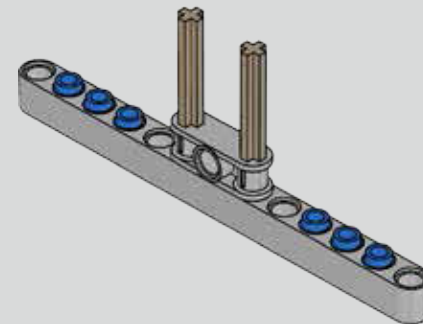

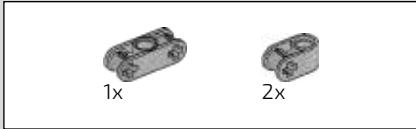

282

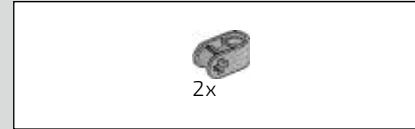
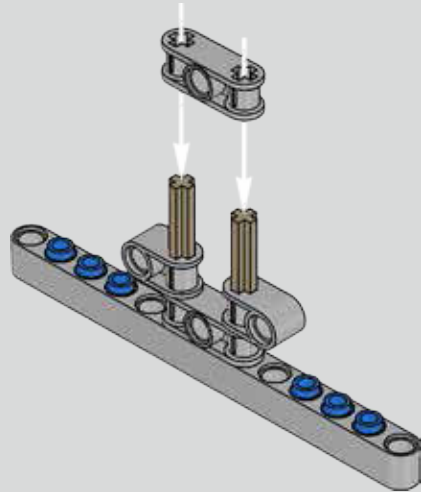

283

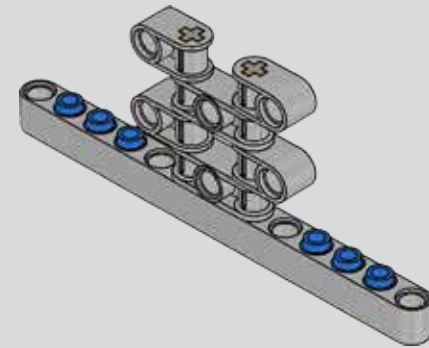

284

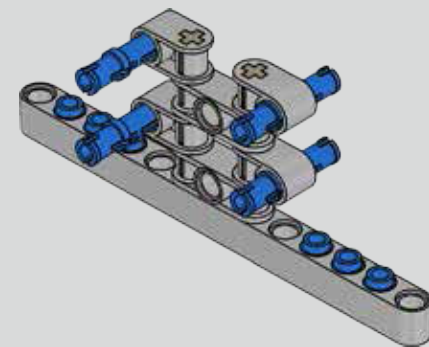

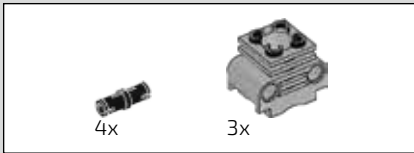

285

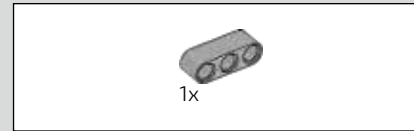
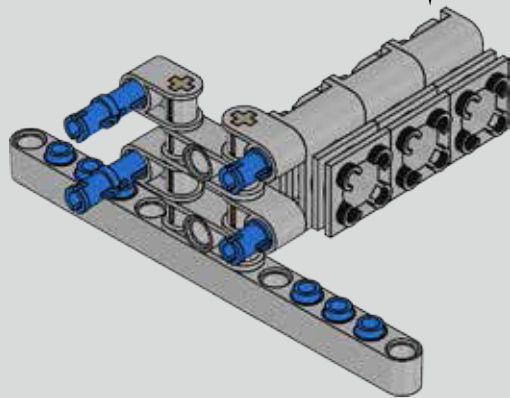
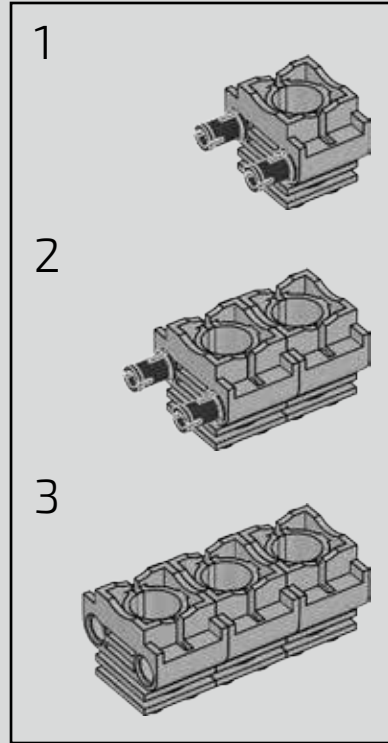

286

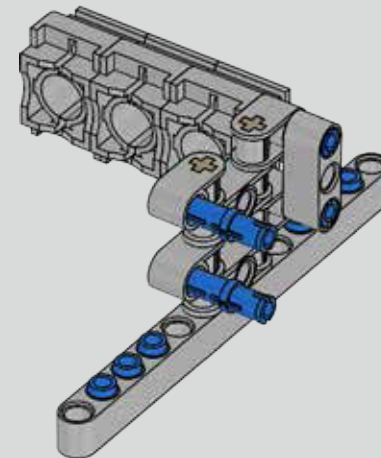
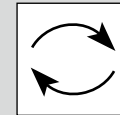

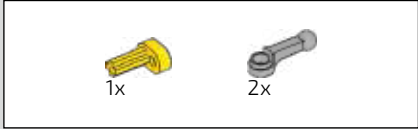
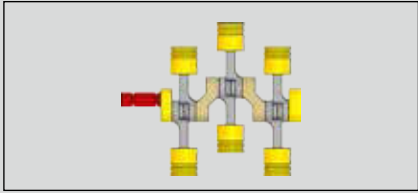

287

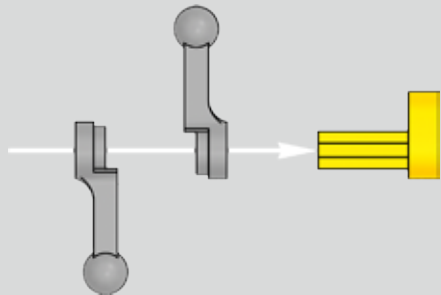

288

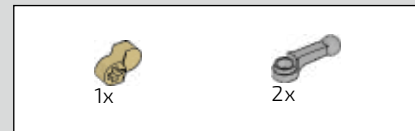
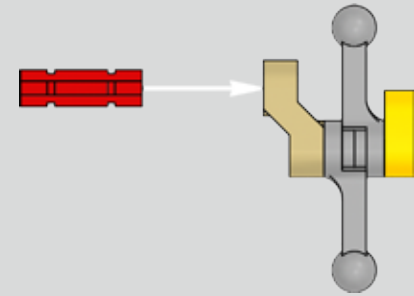

289

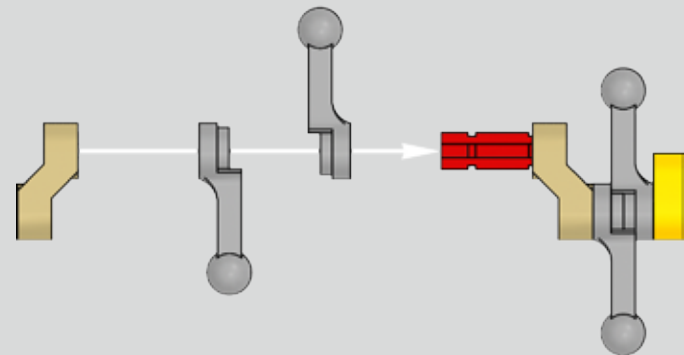



290

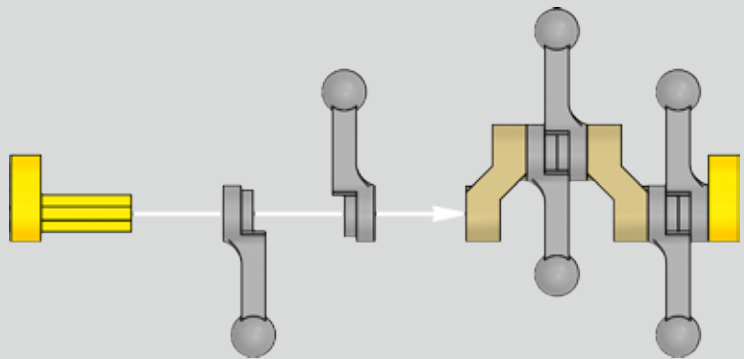

291

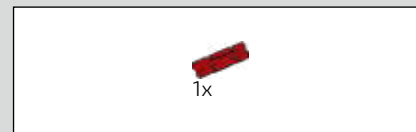
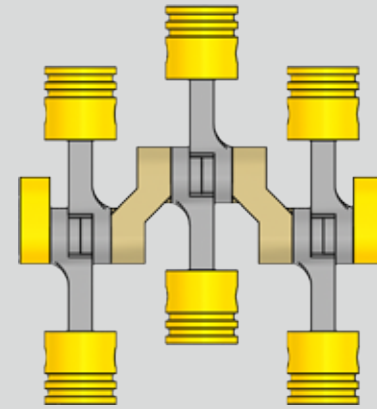

292

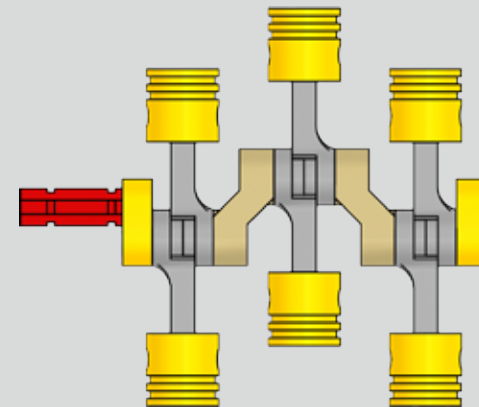

1:1

293

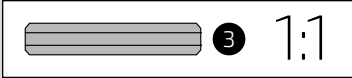
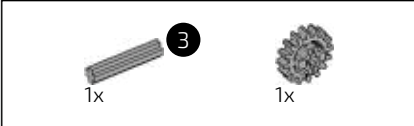
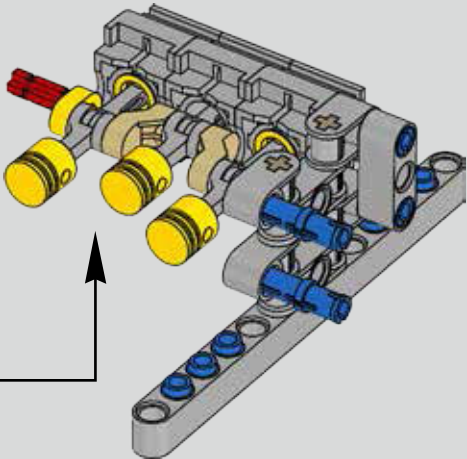

294

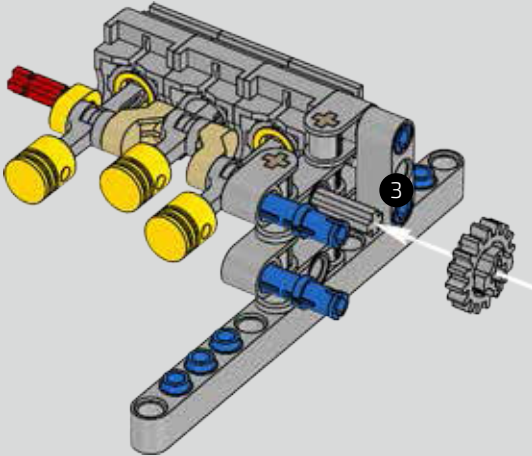

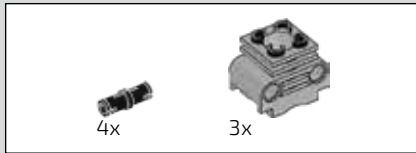

295

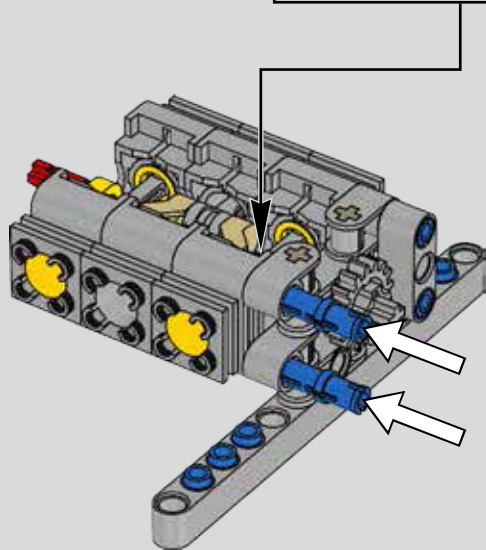
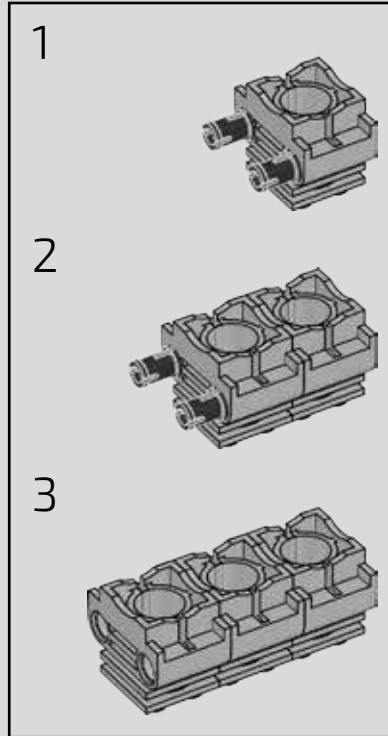

296

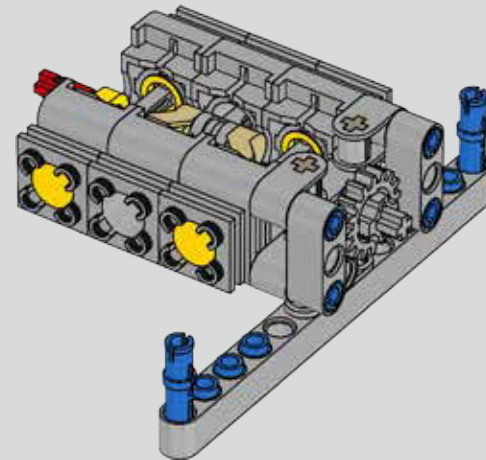

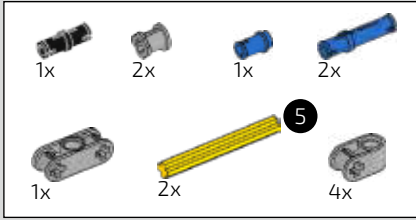

297

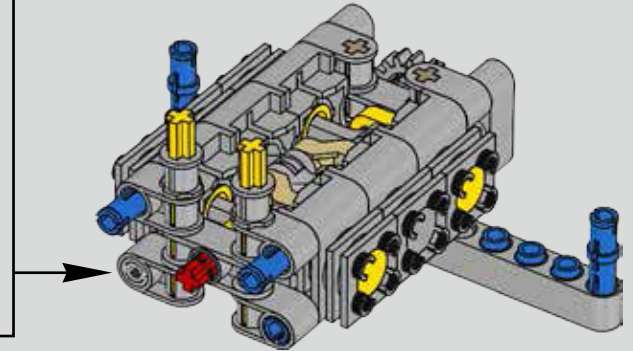
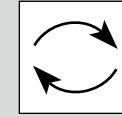
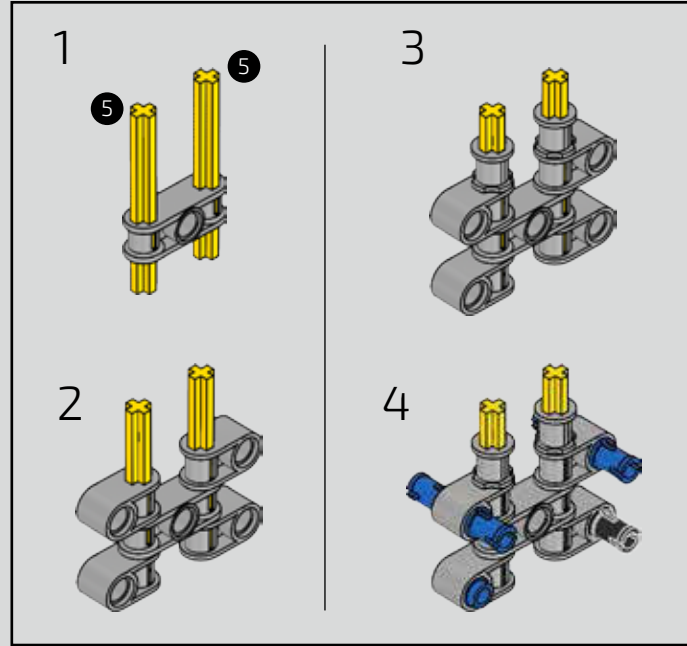

298

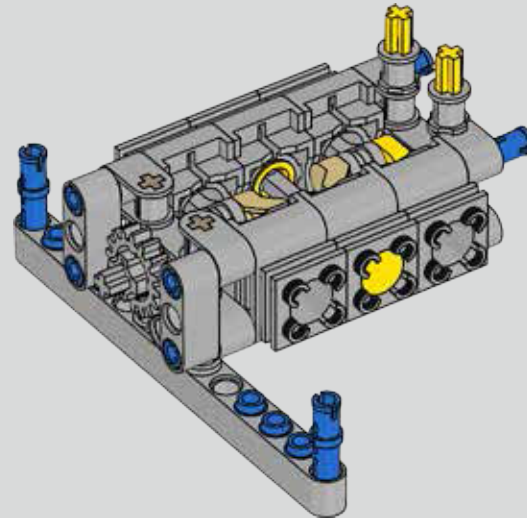
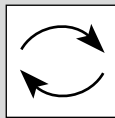

299

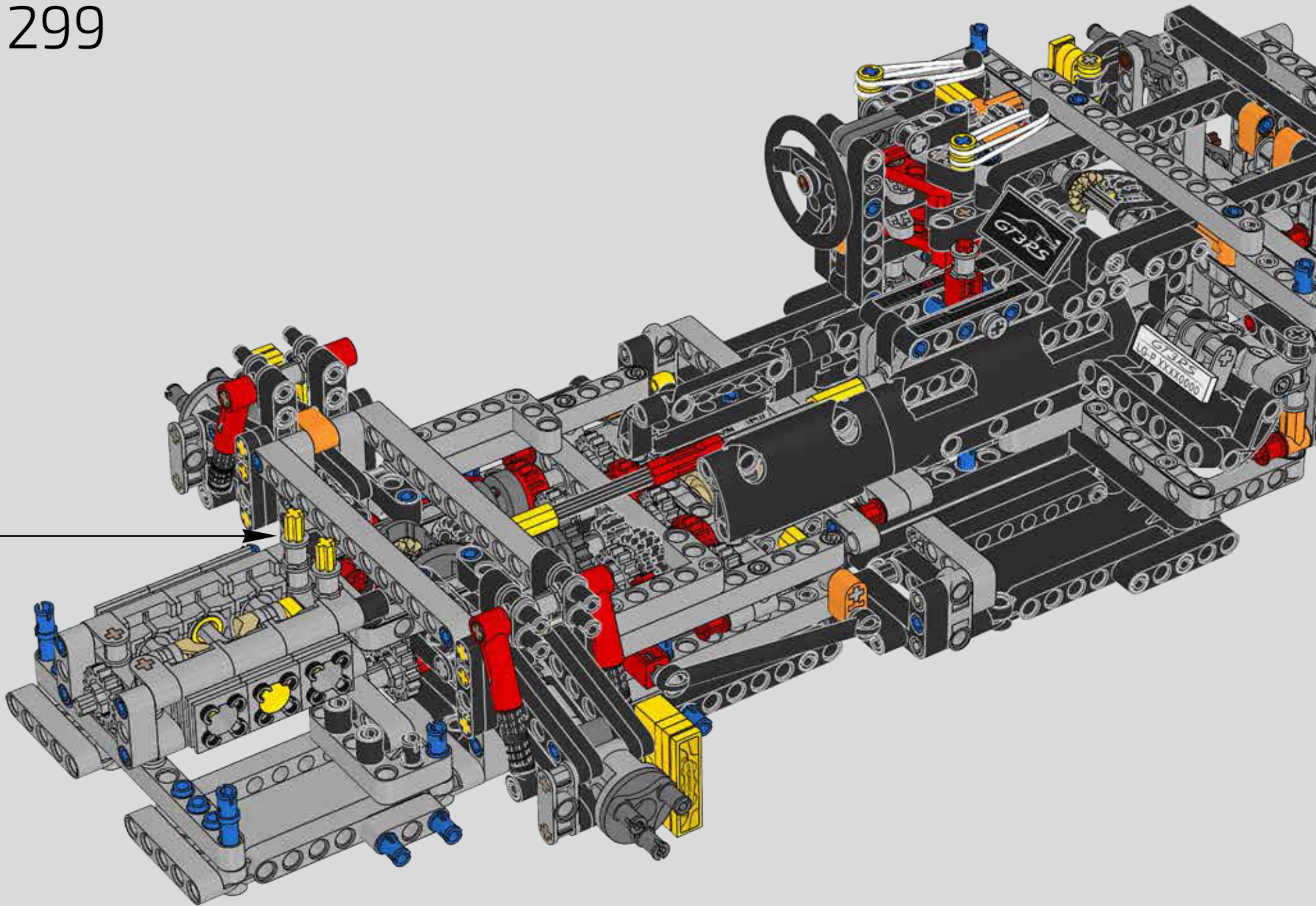

300

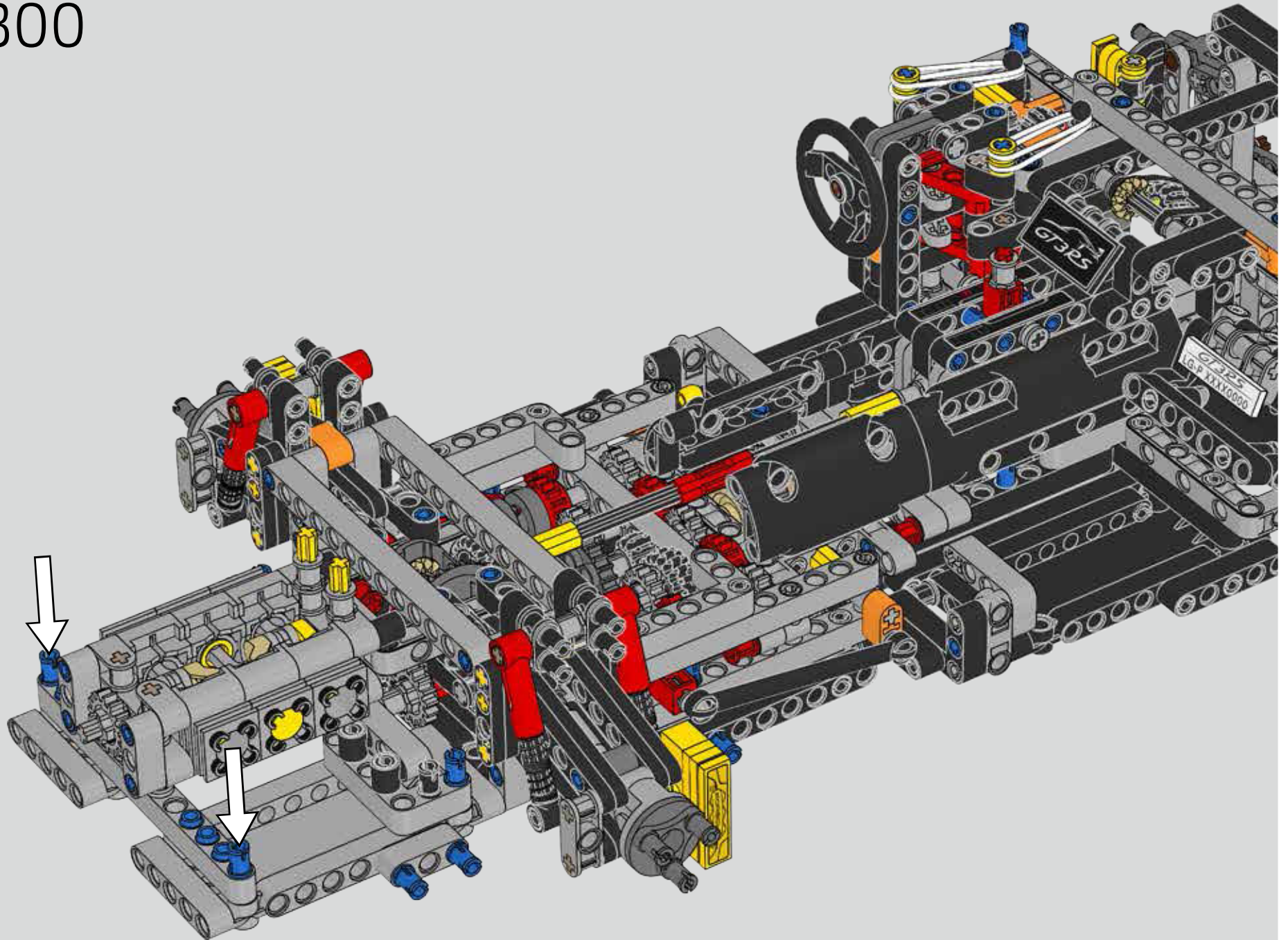

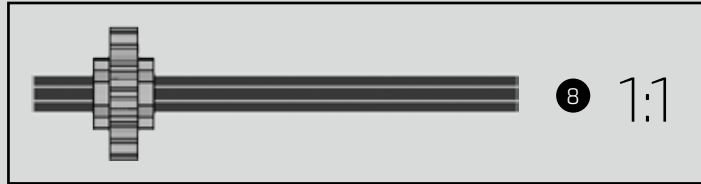
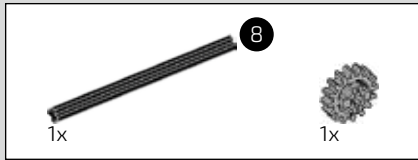

301

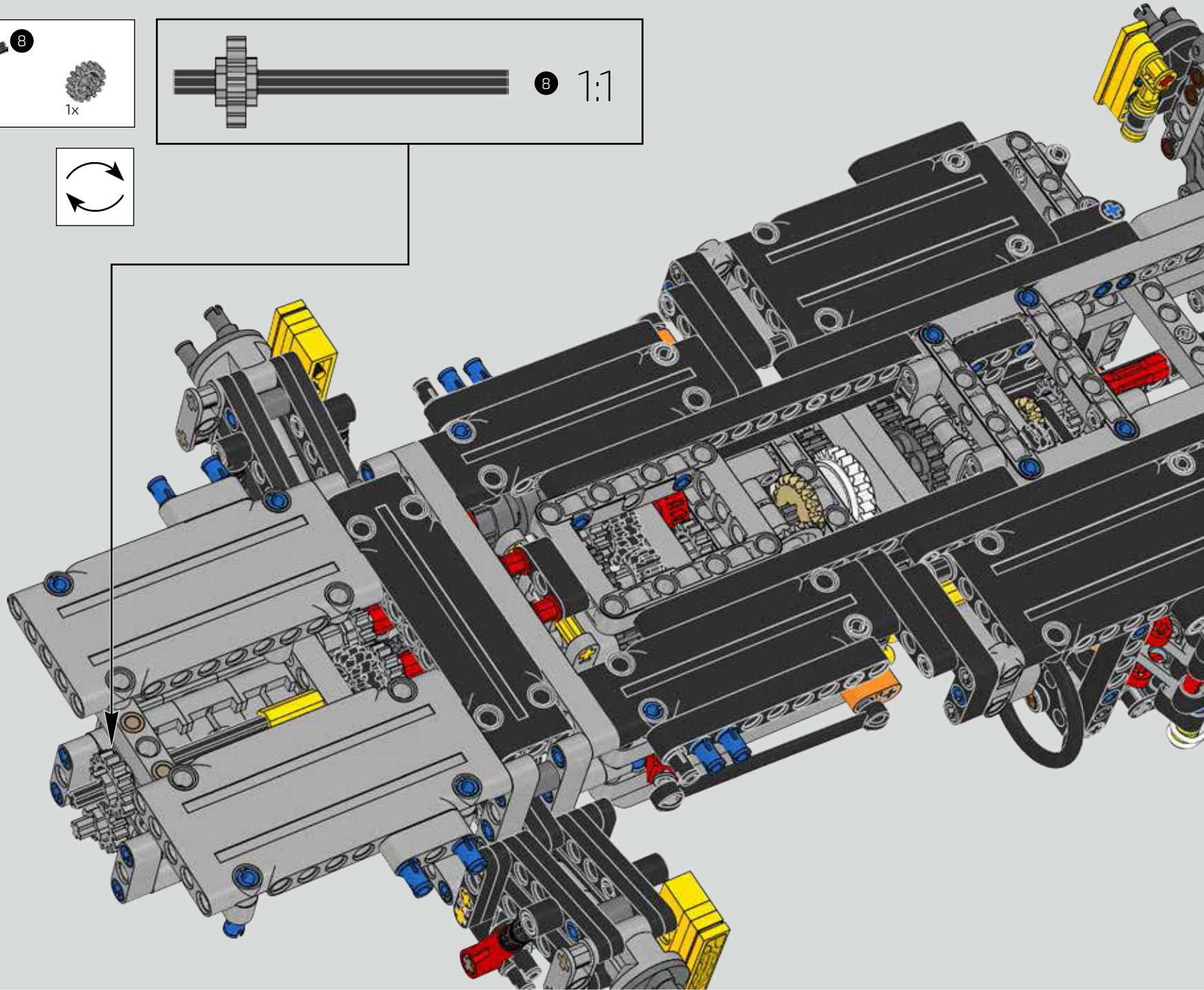
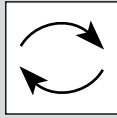

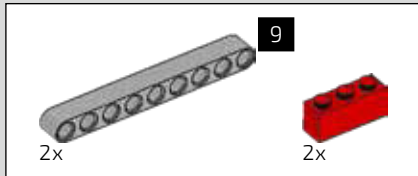

302

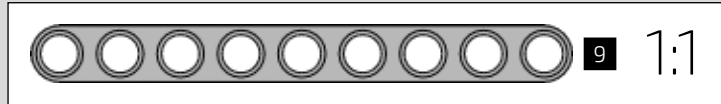
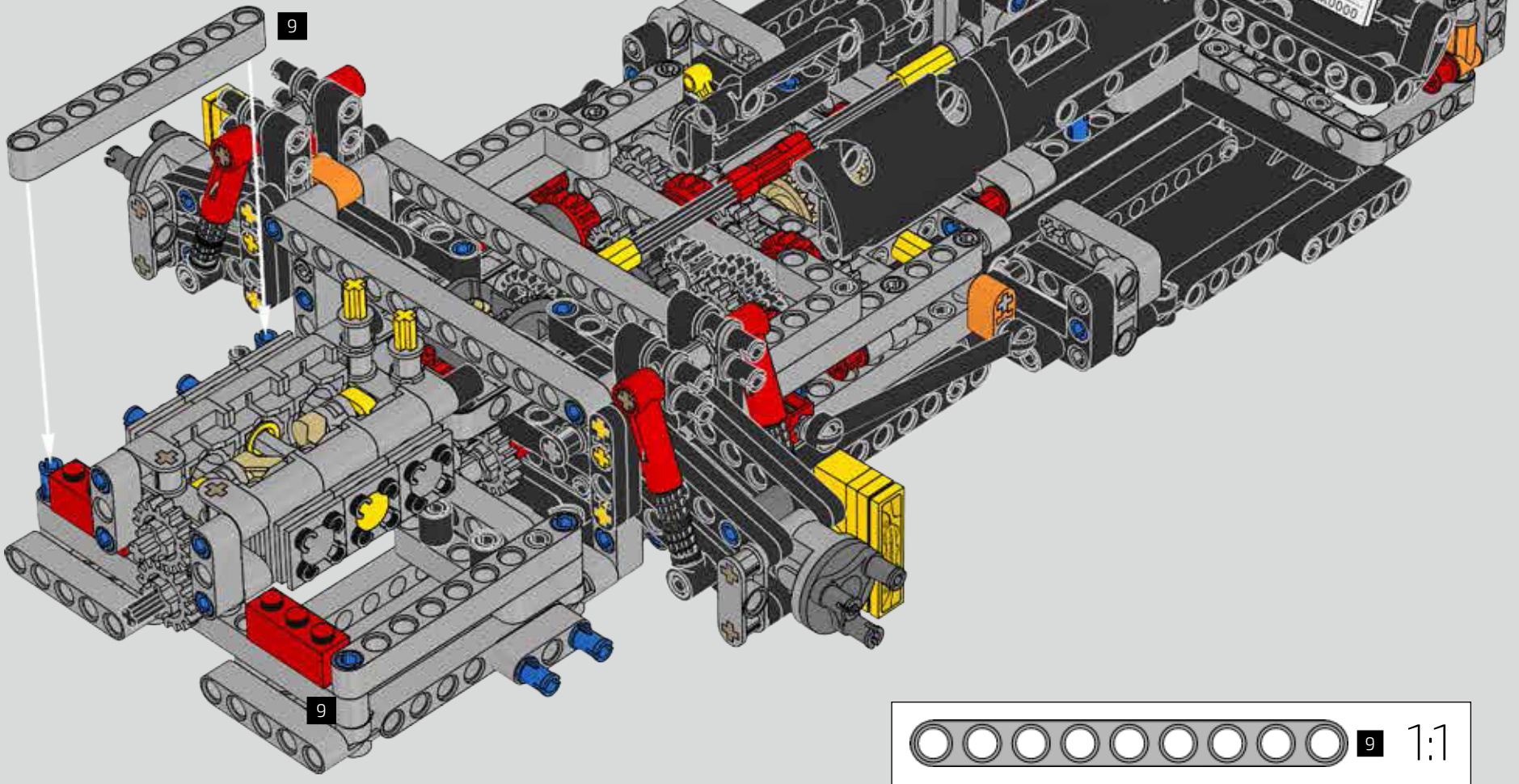
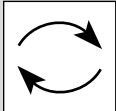

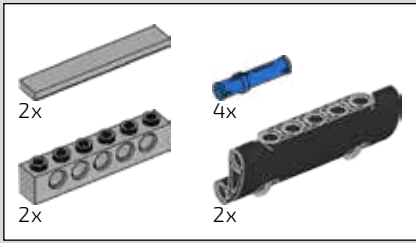

303

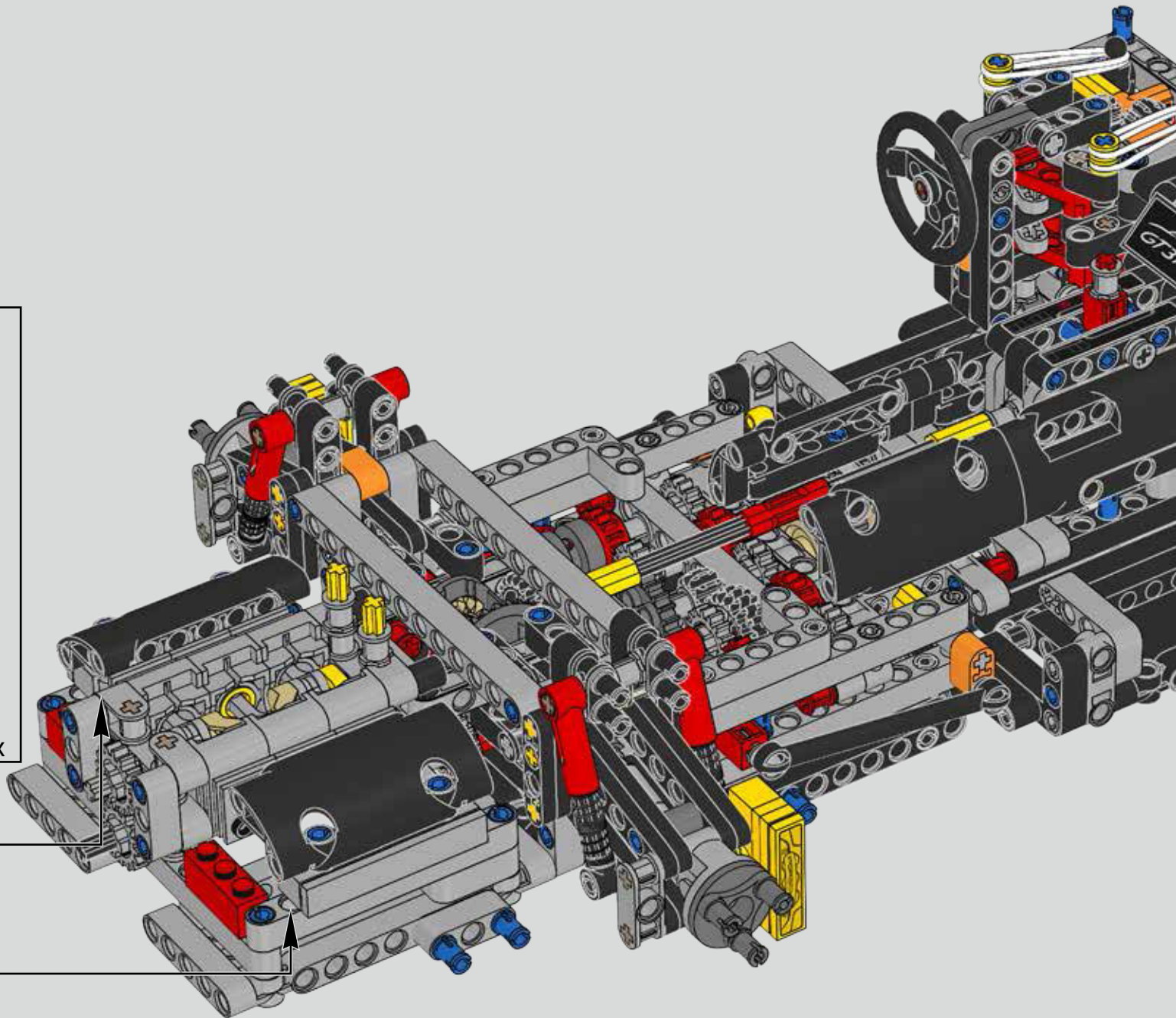
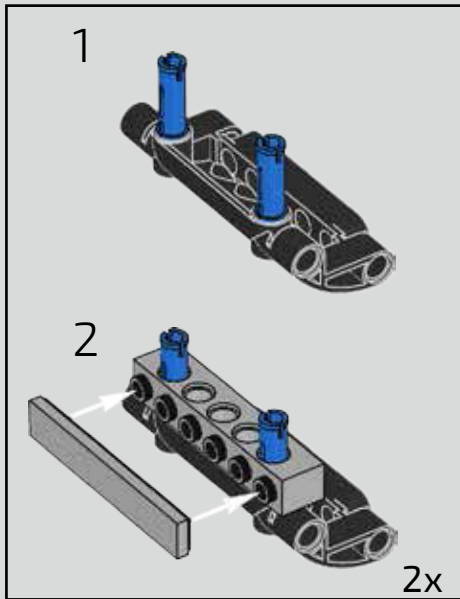

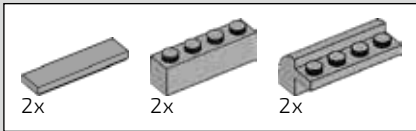

304

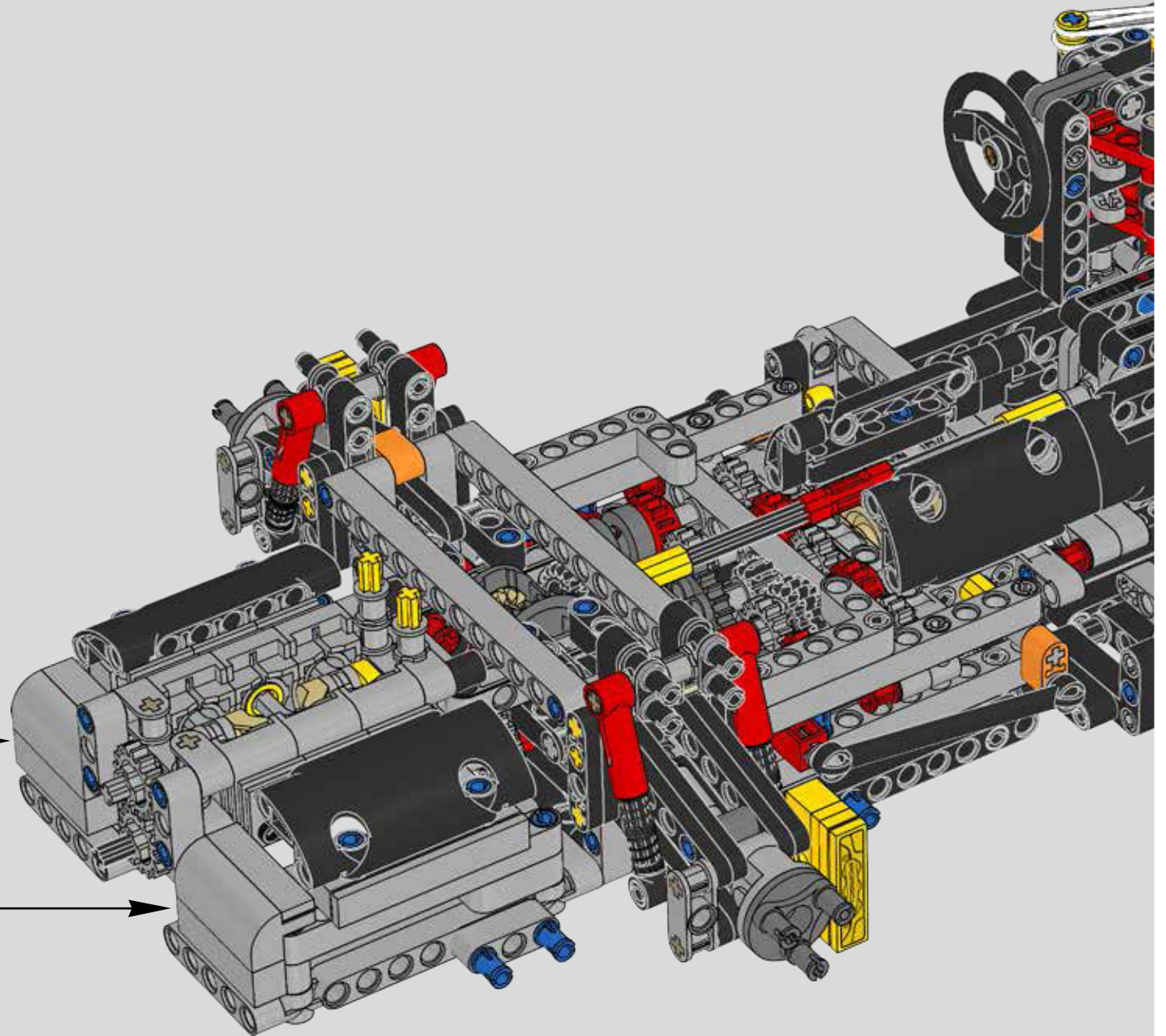
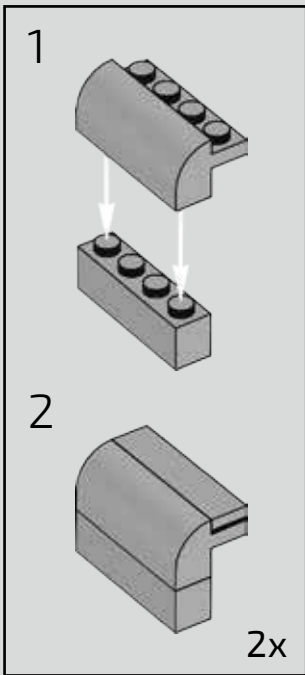

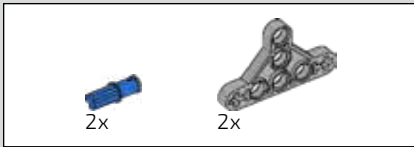

305

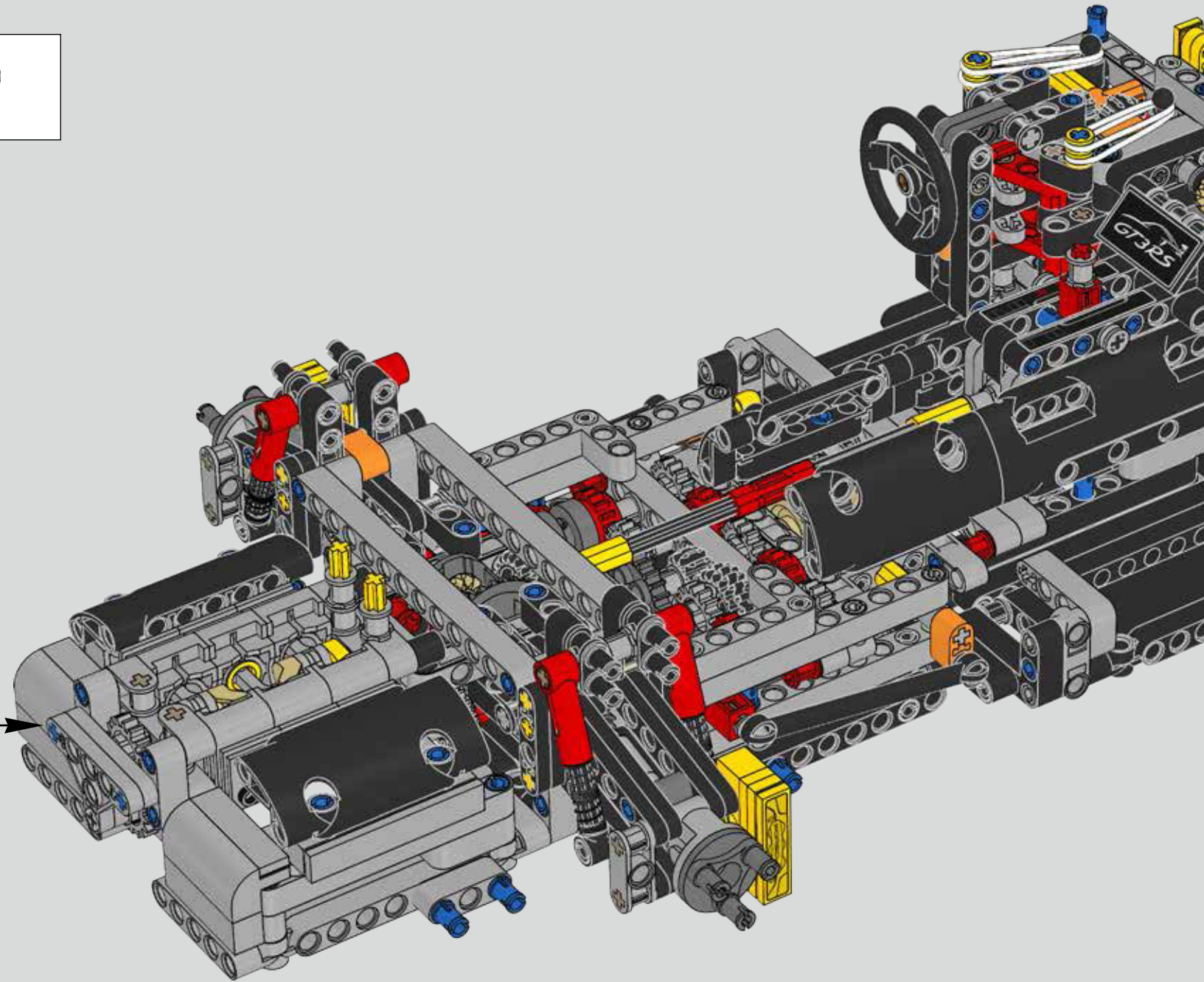
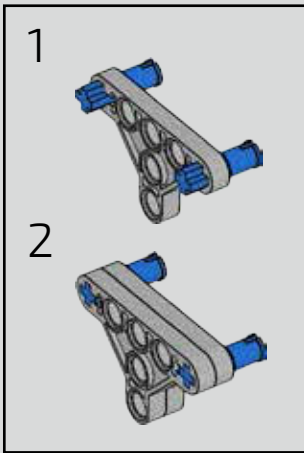

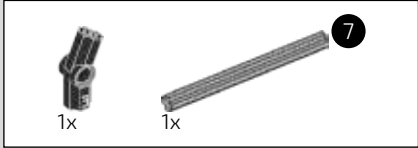
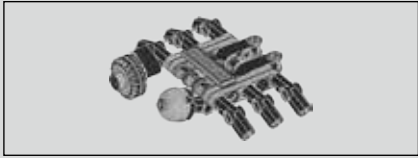

306

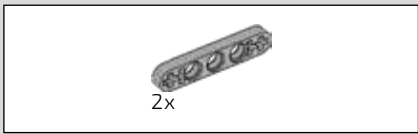
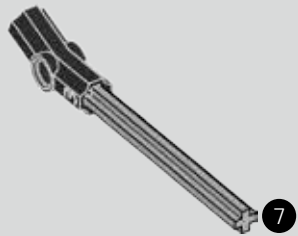

307

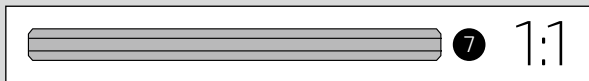
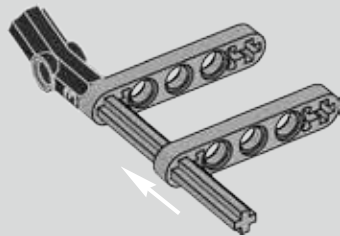

308

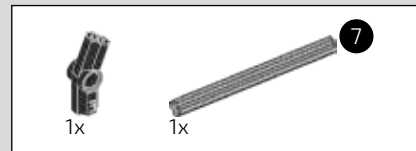
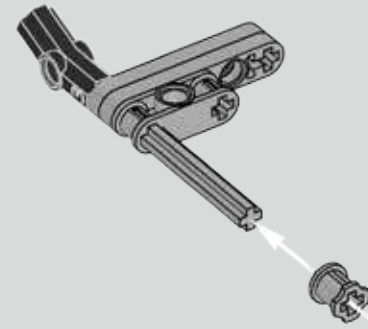

309

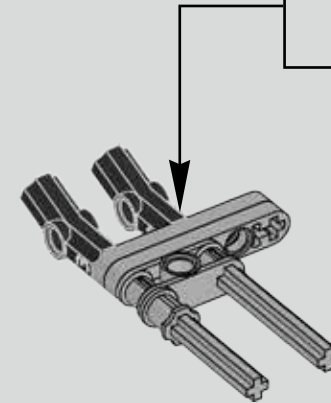
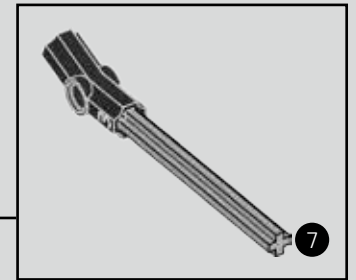

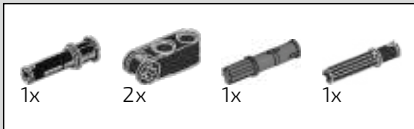

310

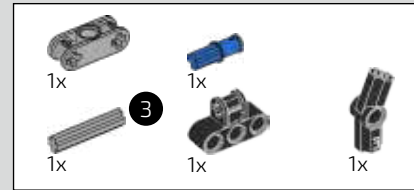
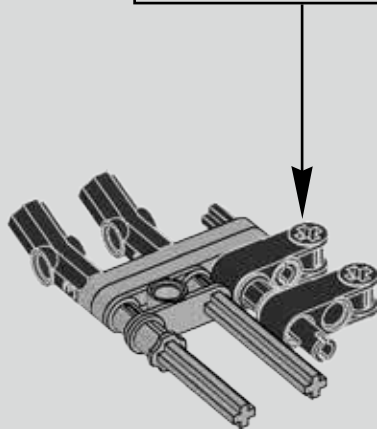
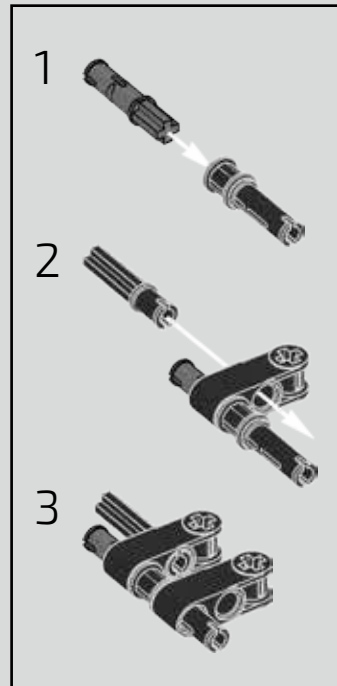

311

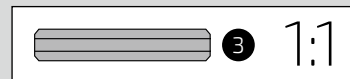
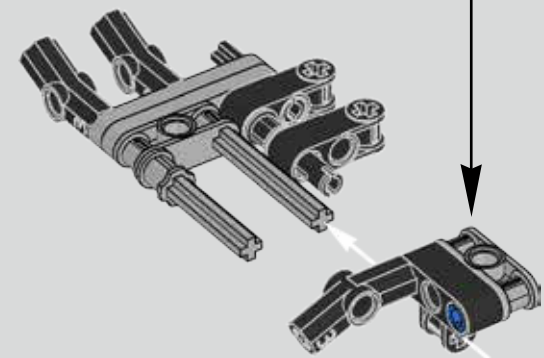
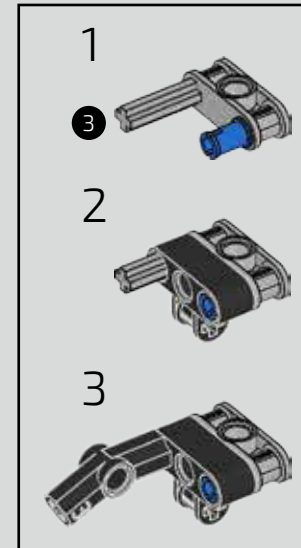

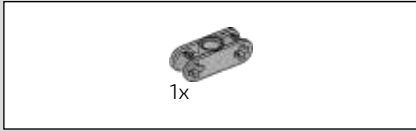

312

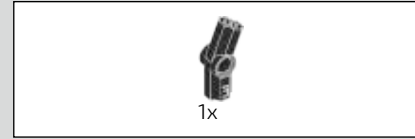
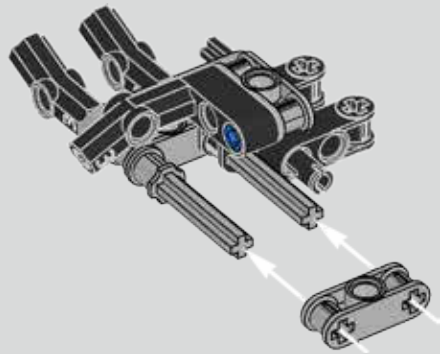

313

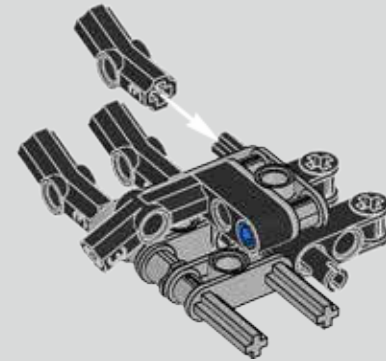

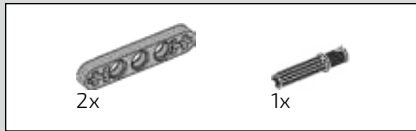

314

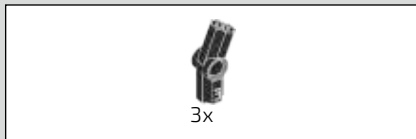
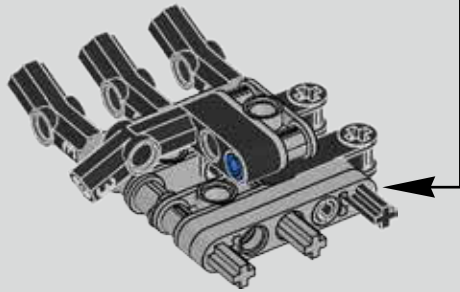
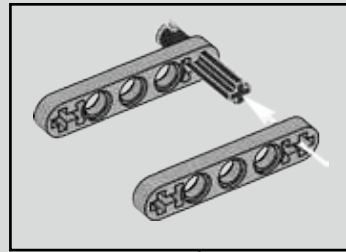

315

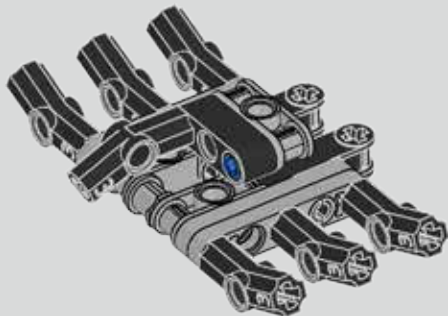

316

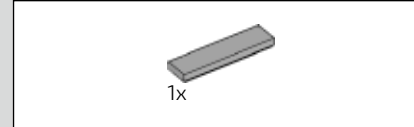
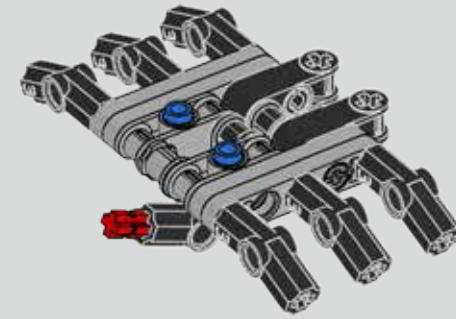
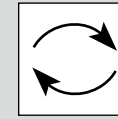

317

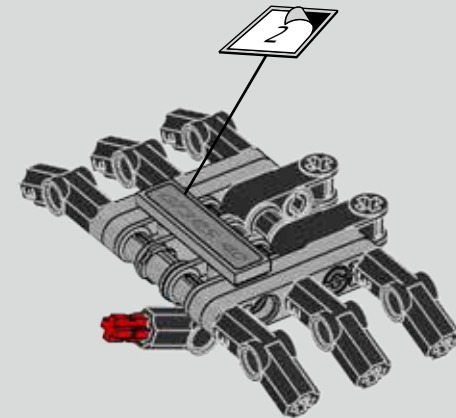

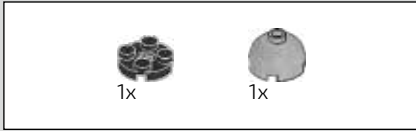

318

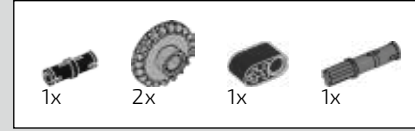
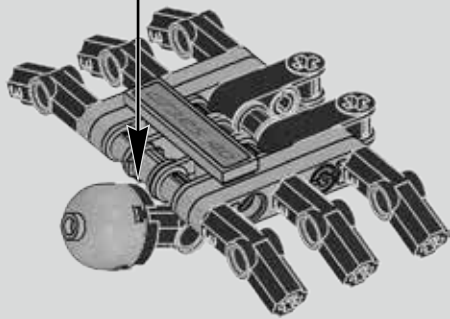
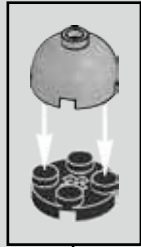

319

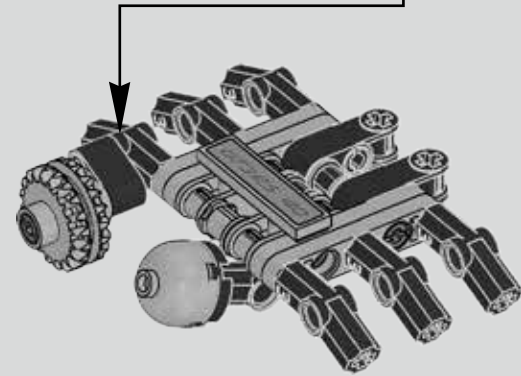
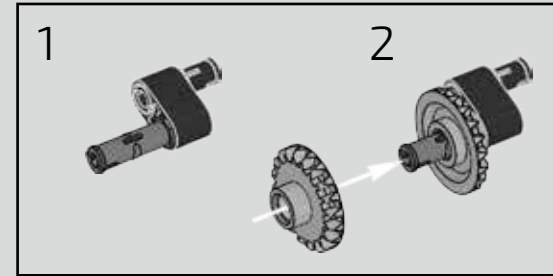

320

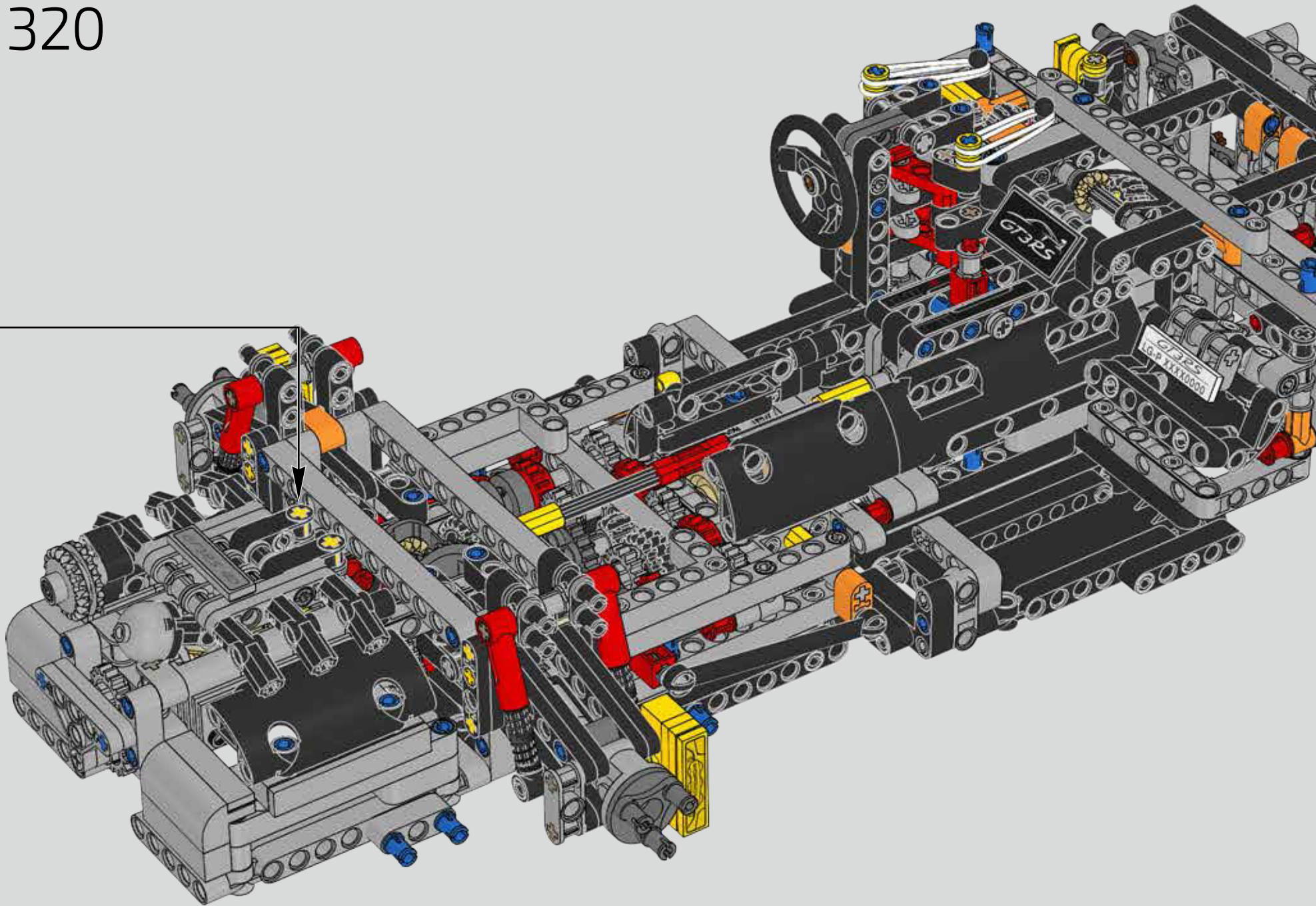

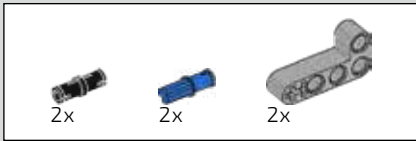

321

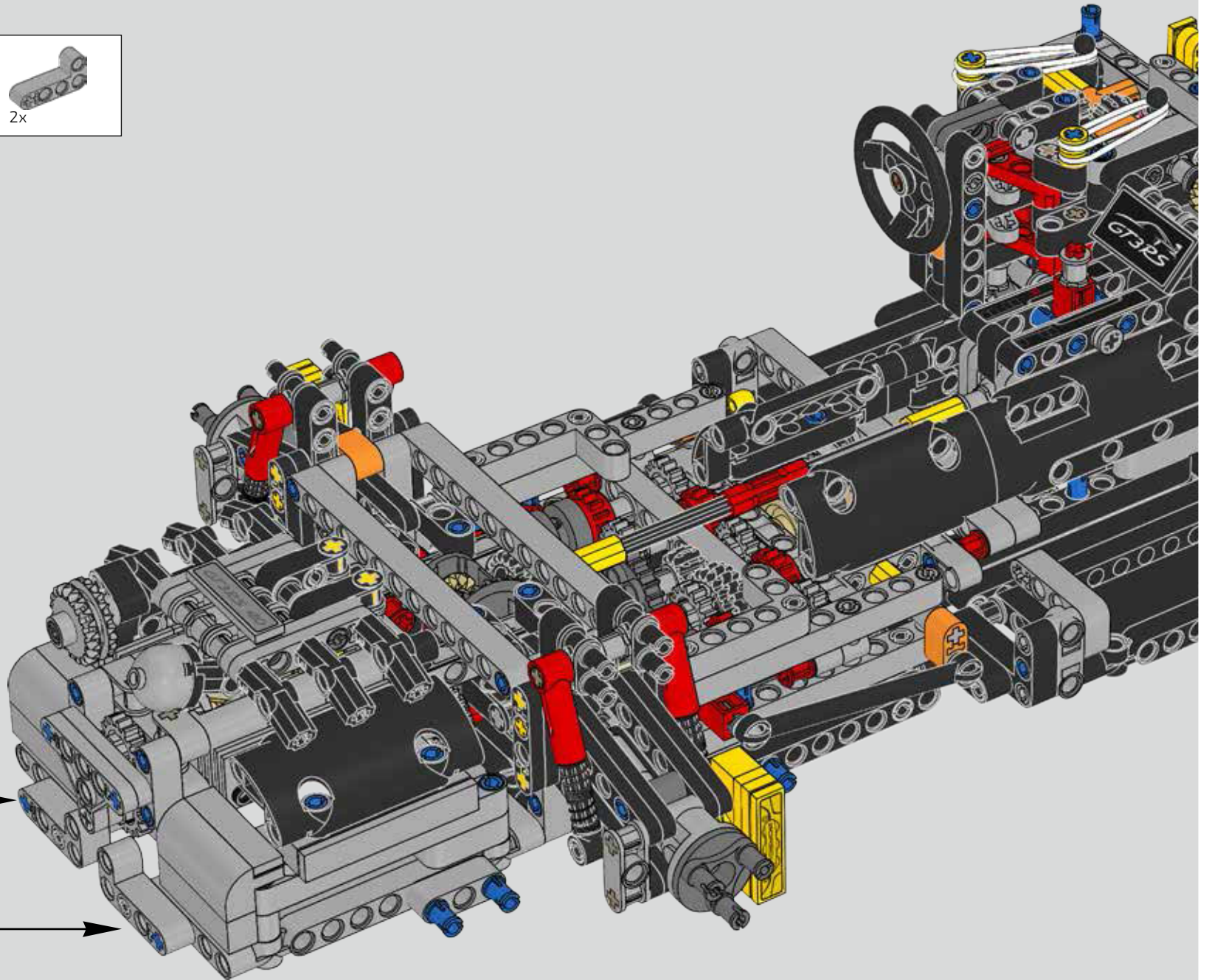
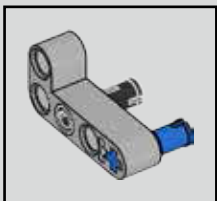
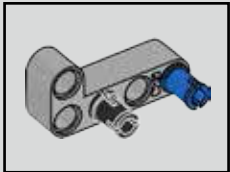



322

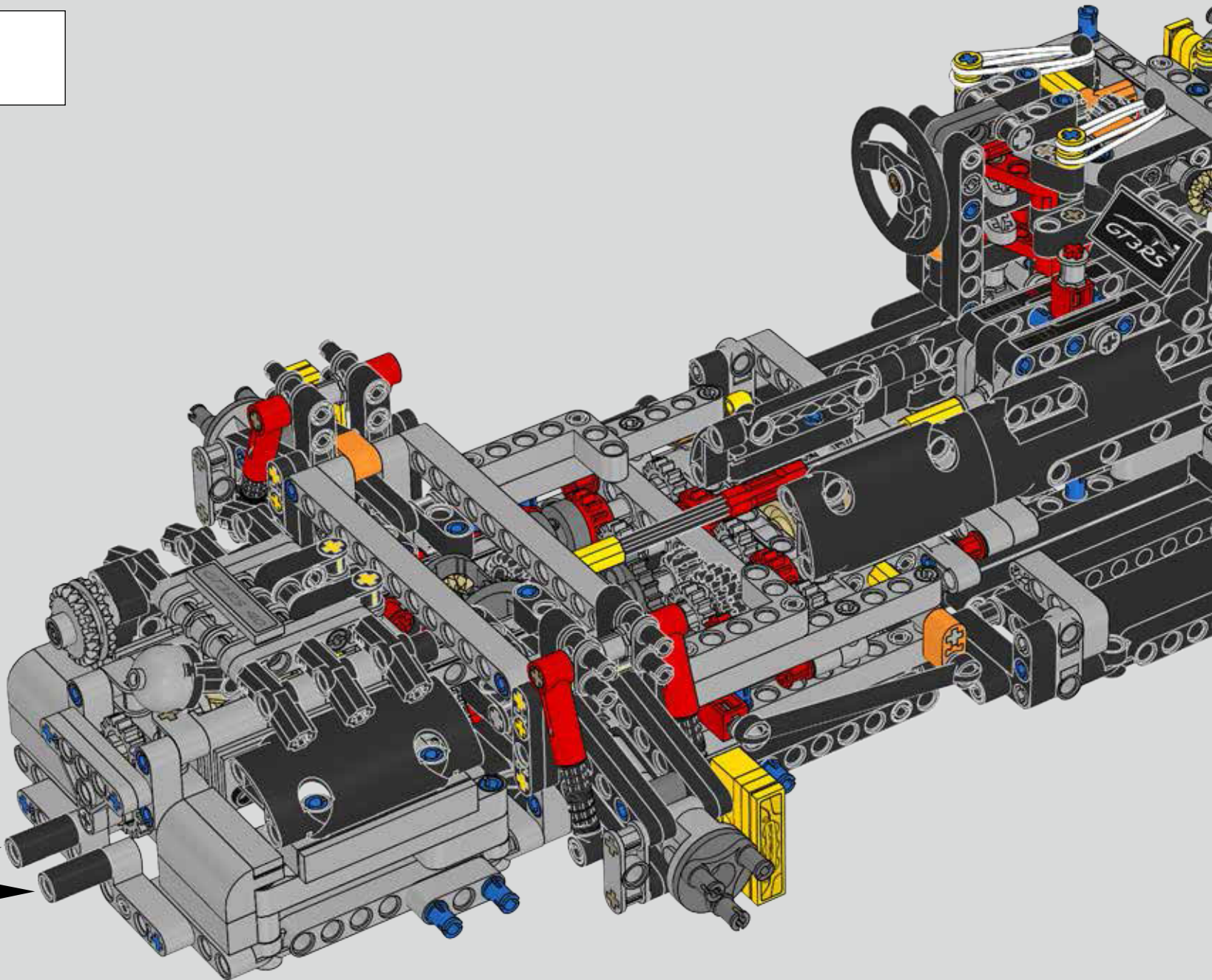
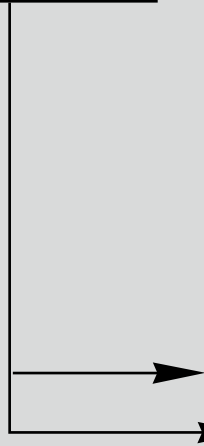
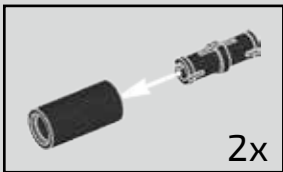

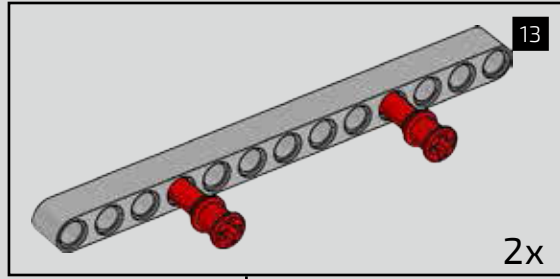
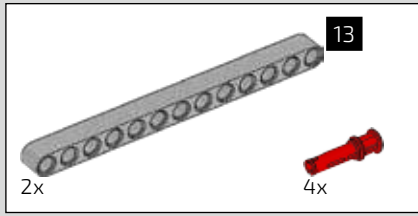

323

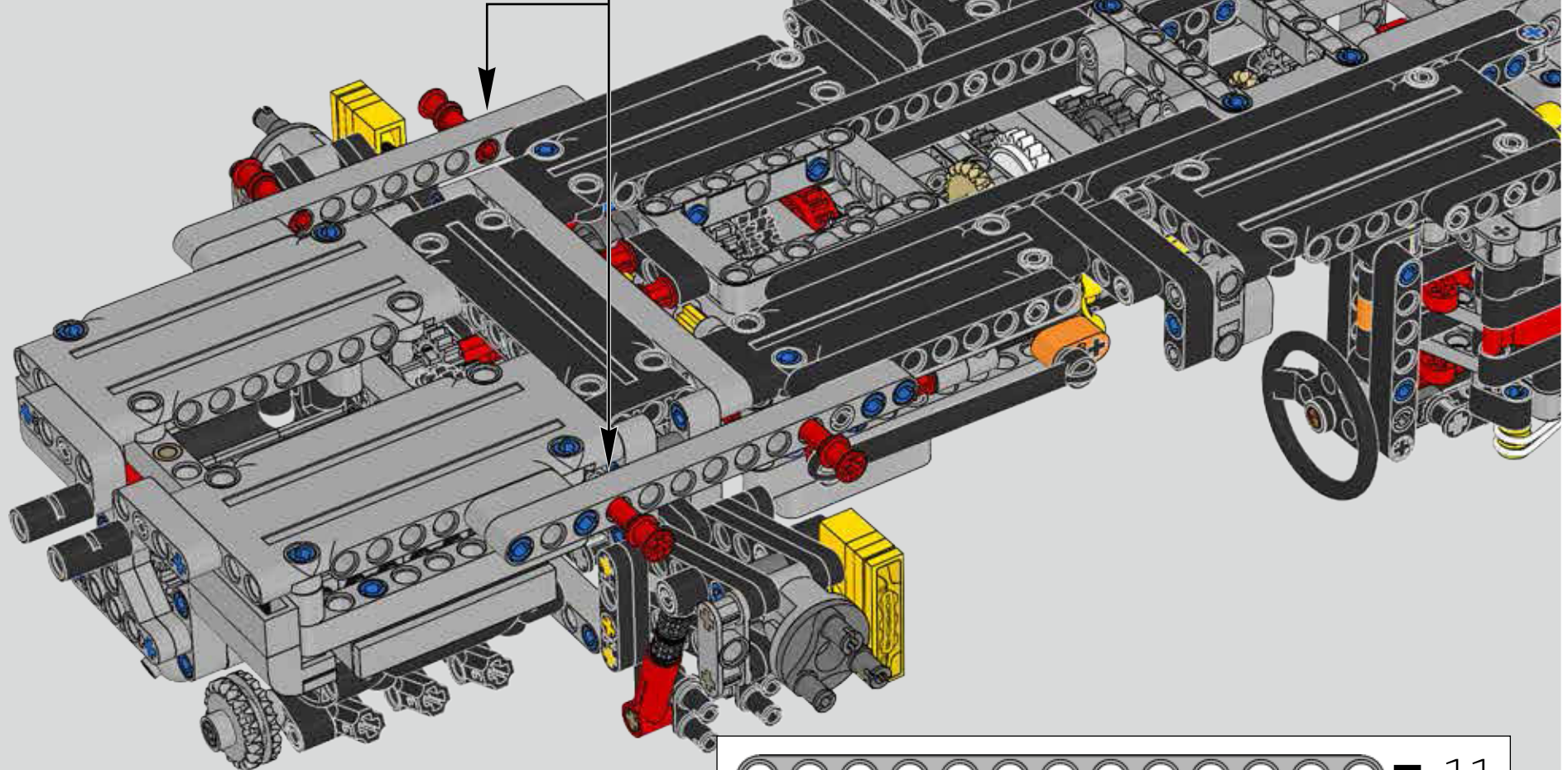
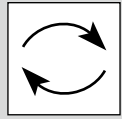



2

During production of the real 911 GT3 RS there is a stage called the 'marriage', where the drivetrain is connected to the body of the car. In this box you build the floor plan of the 911 GT3 RS, complete with seats and roll cage, before placing it over the drivetrain in a similar way to the production of the real 911 GT3 RS.

Pendant la production de la vraie 911 GT3 RS, il y a une étape appelée « mariage », où le système de transmission est relié à la carrosserie de la voiture. Avec cette boîte, vous construisez le plancher de la 911 GT3 RS, avec les sièges et la cage, avant de le placer sur le système de transmission tout comme dans la production de la vraie 911 GT3 RS.



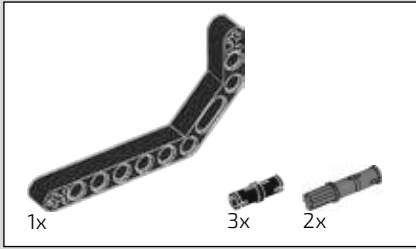

324

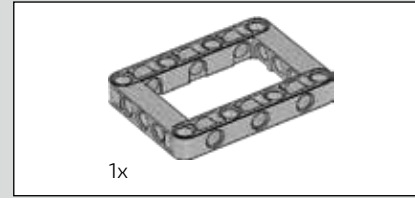
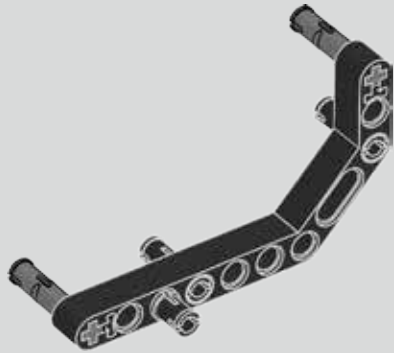

325

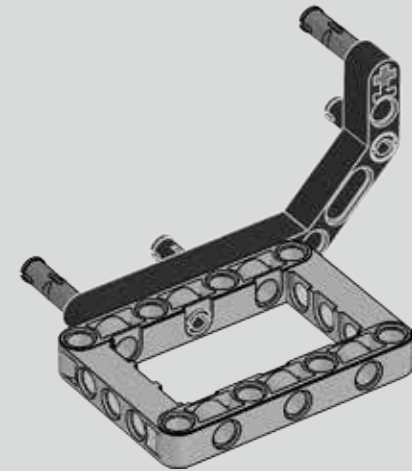

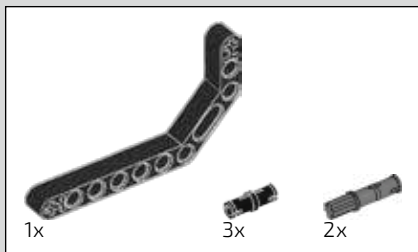

326

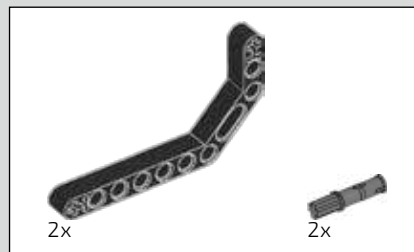
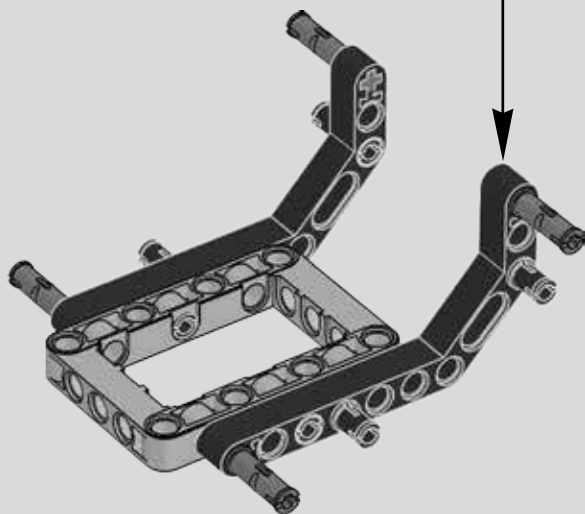
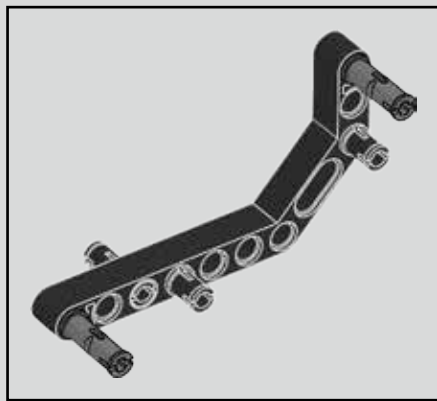

327

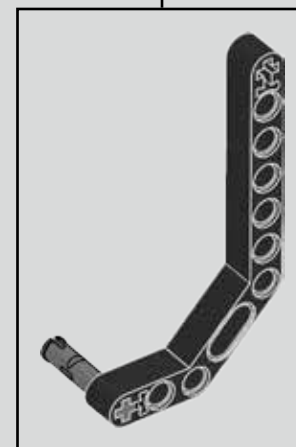
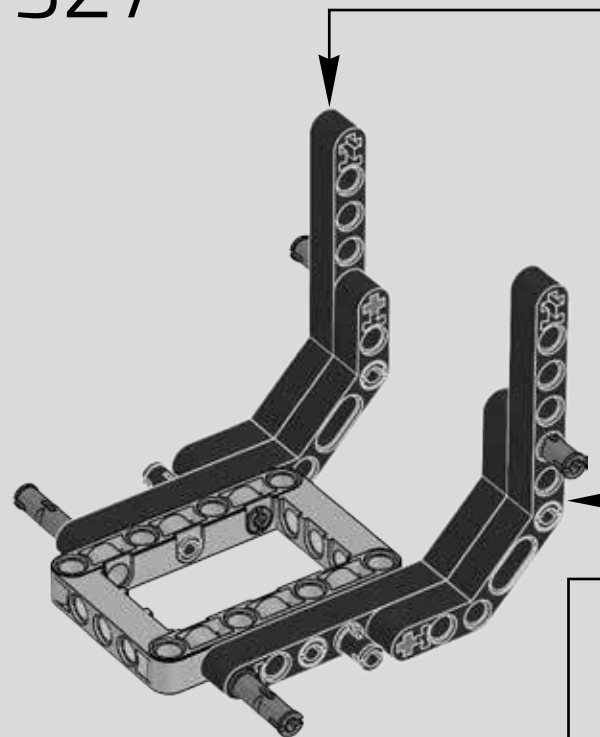
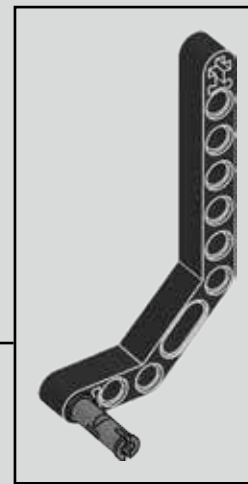

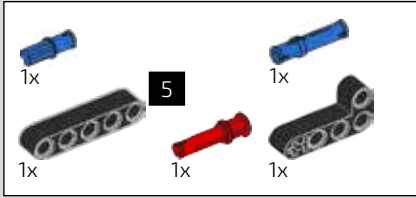

328

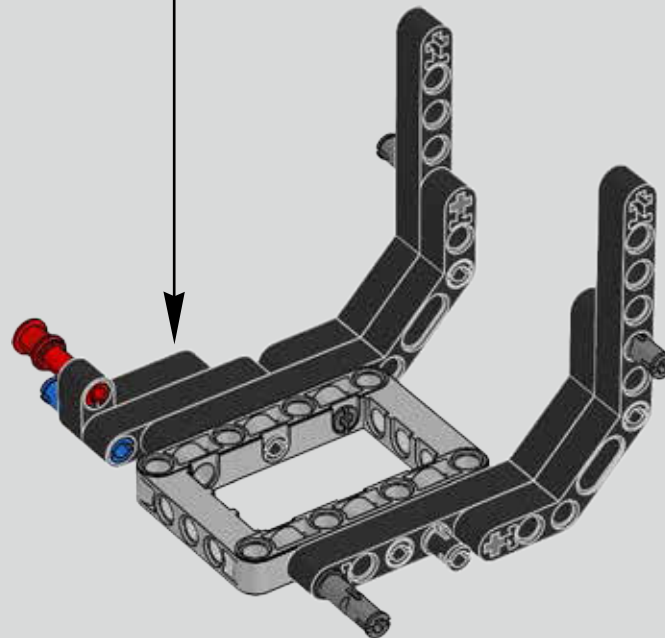
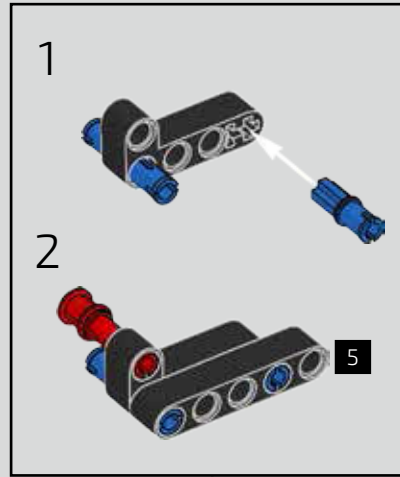

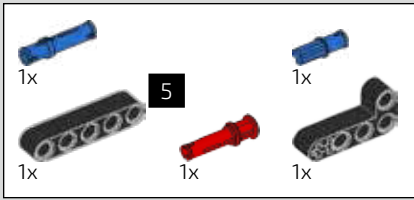

329

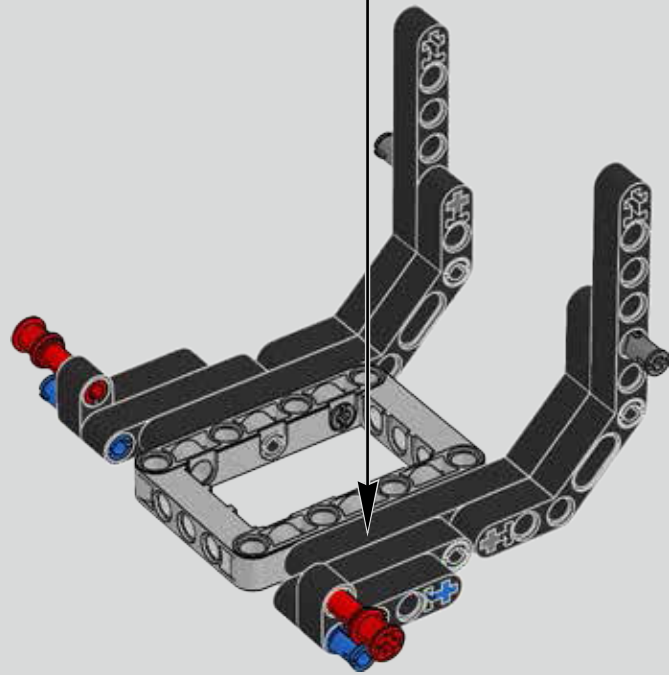
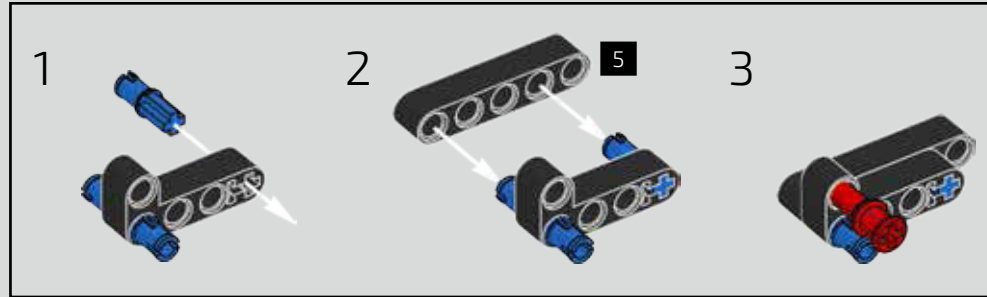

330

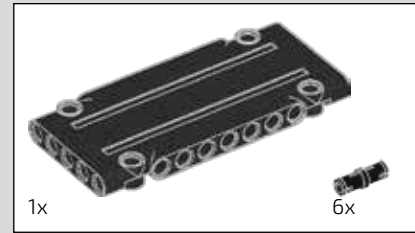
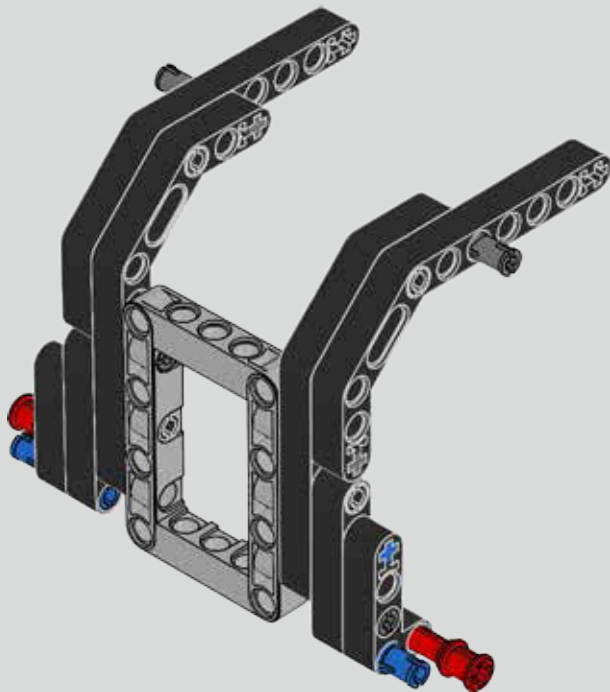
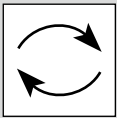

331

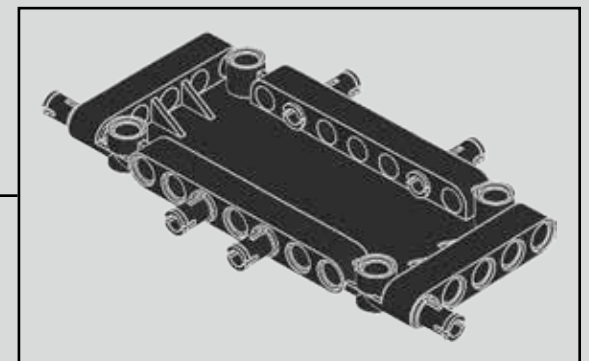
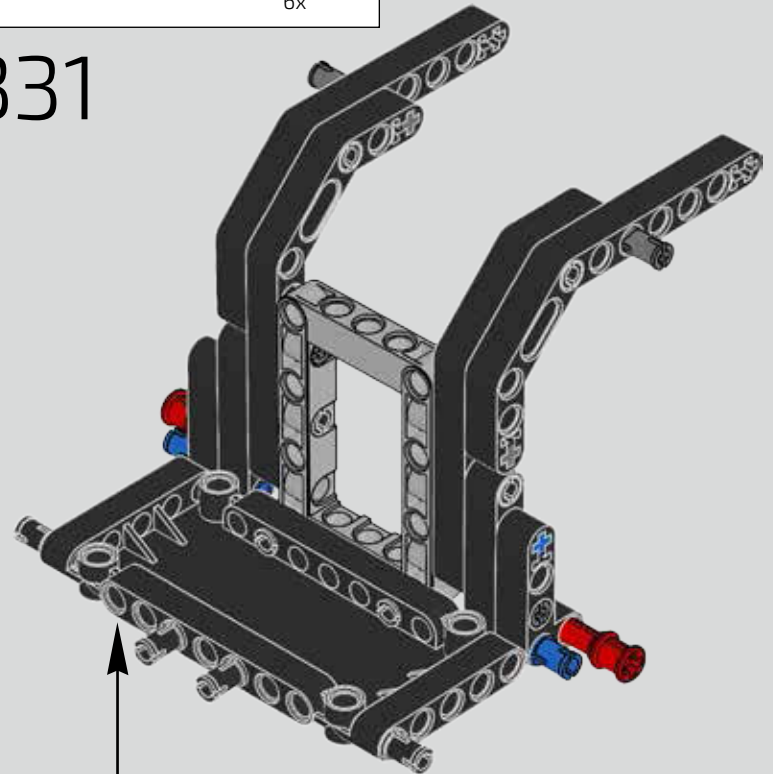

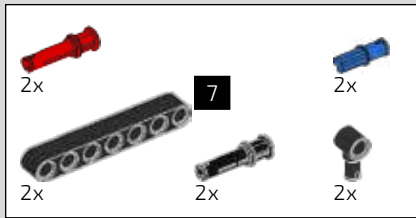

332

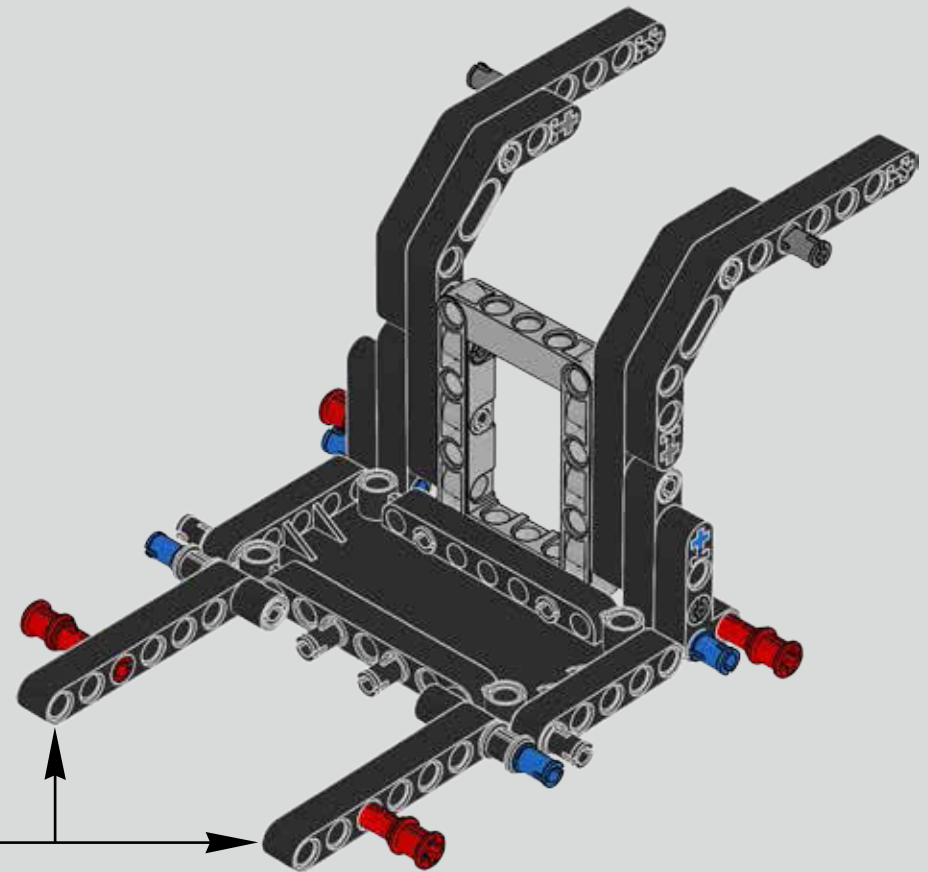
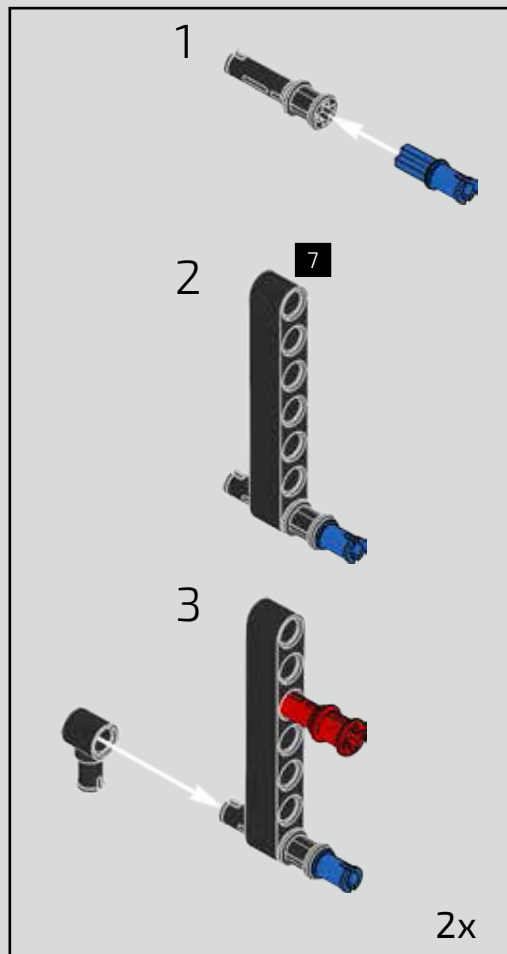

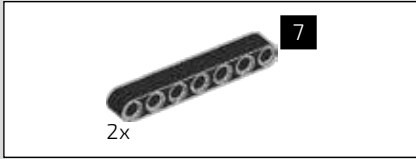

333

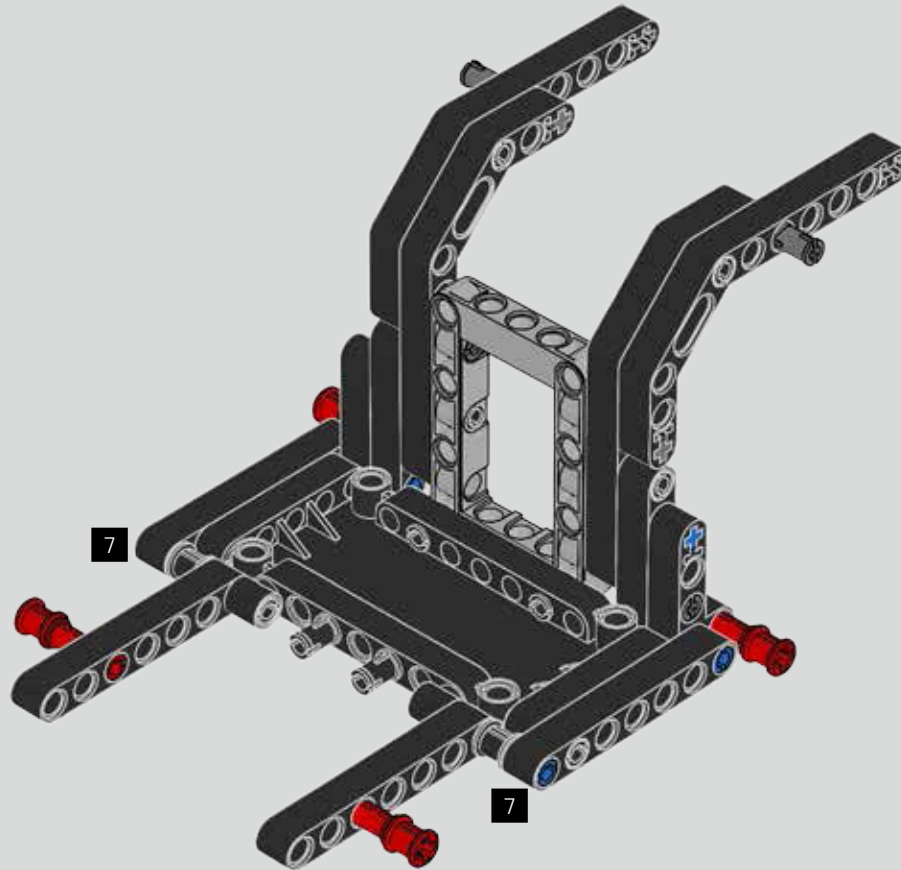

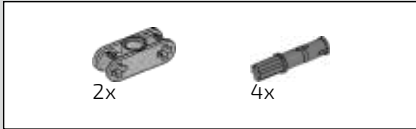

334

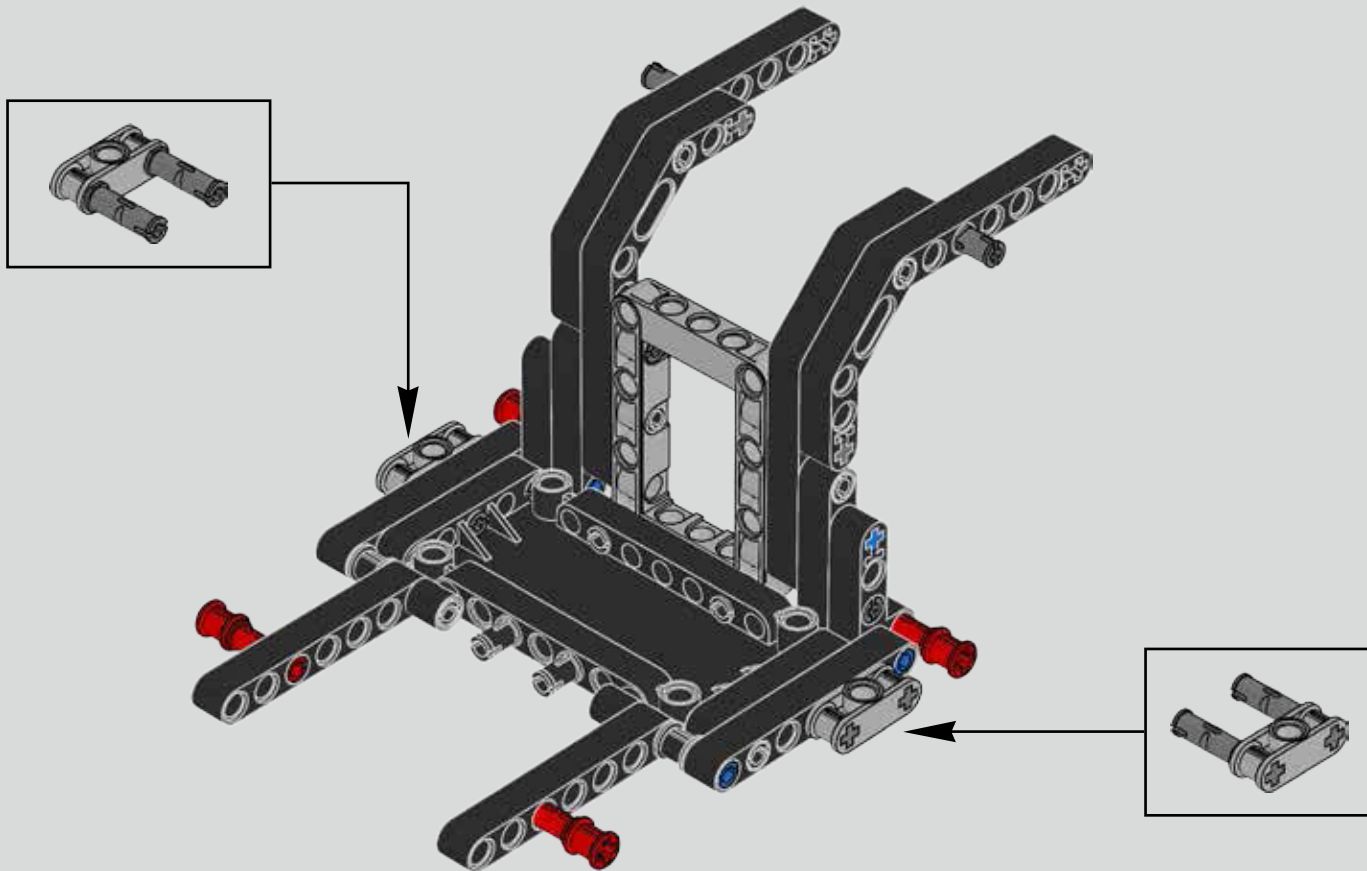

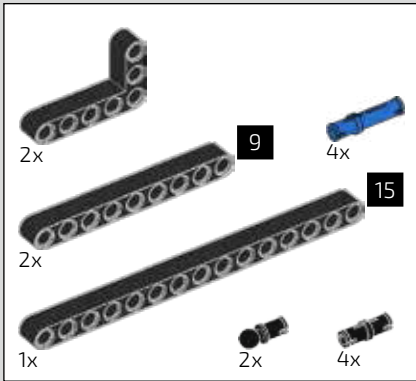

335

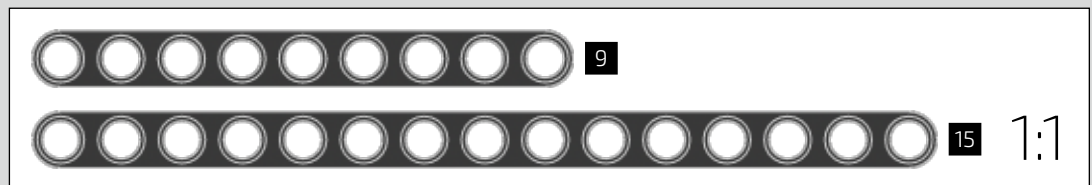
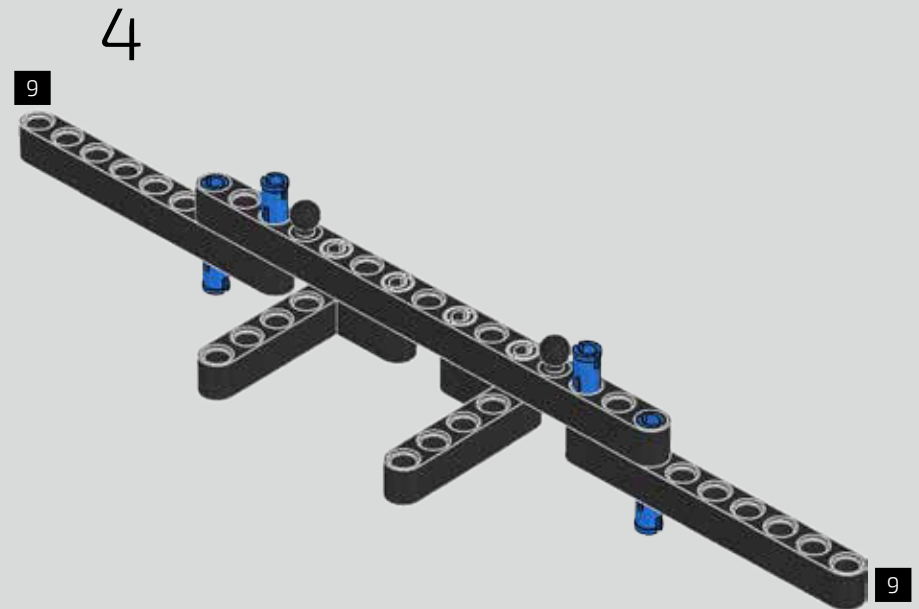
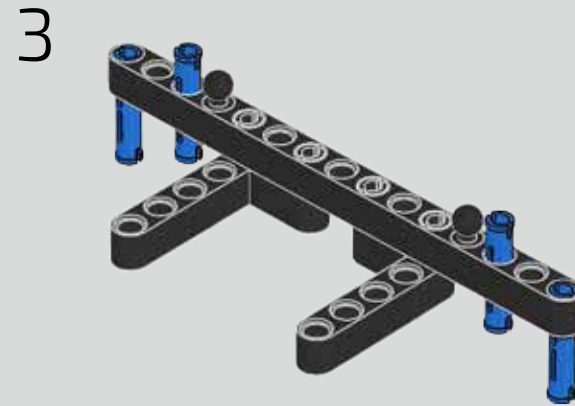
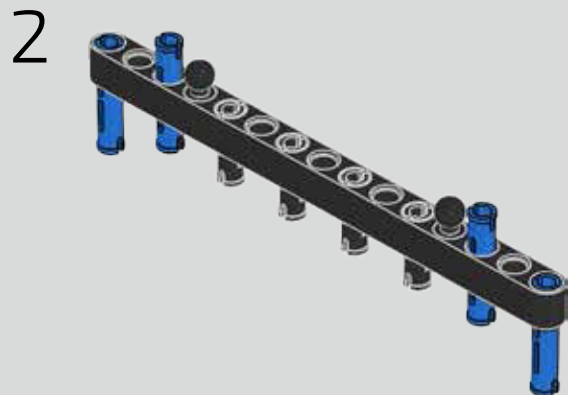
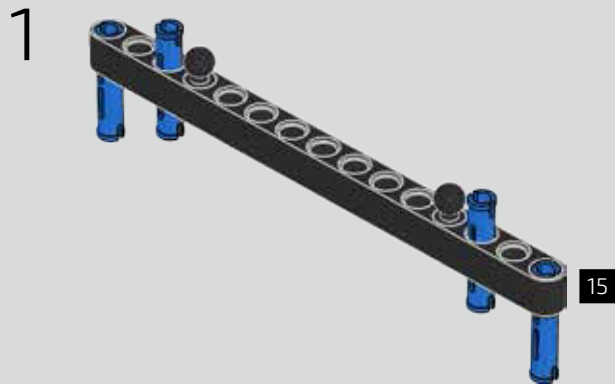

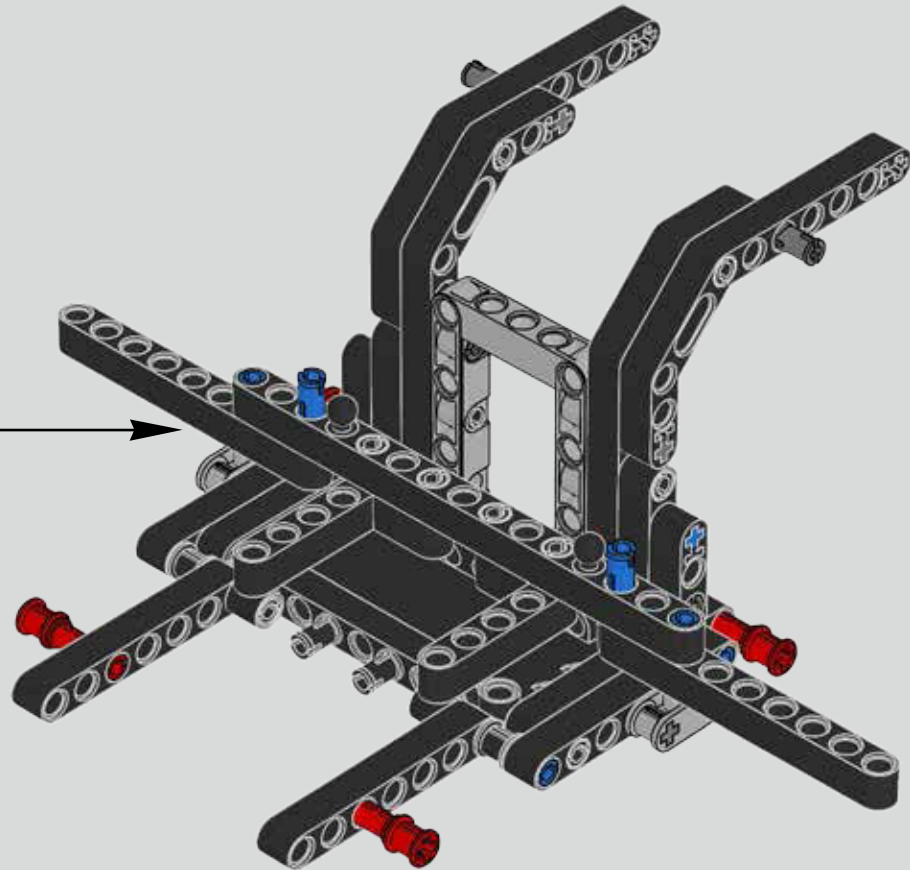

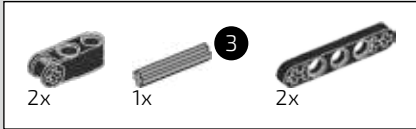

336

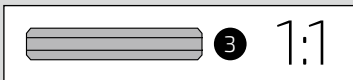
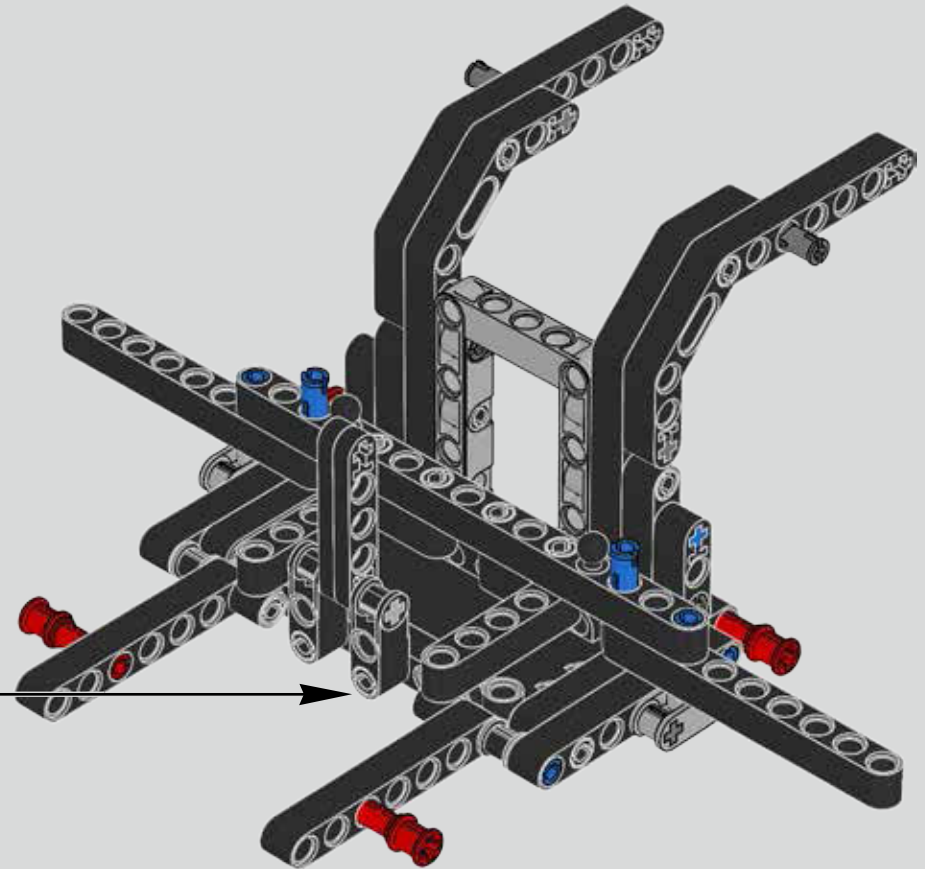
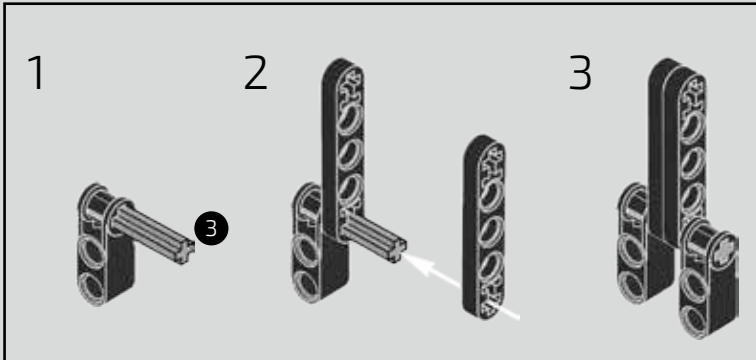

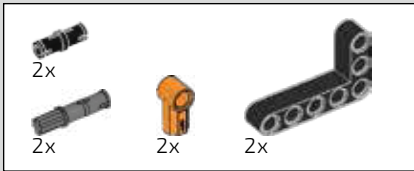

337

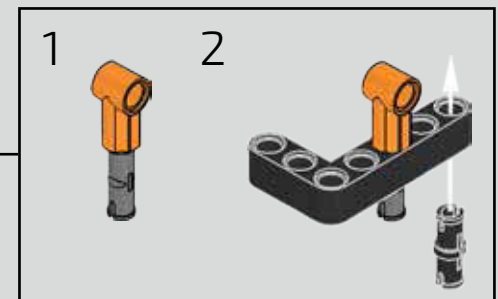
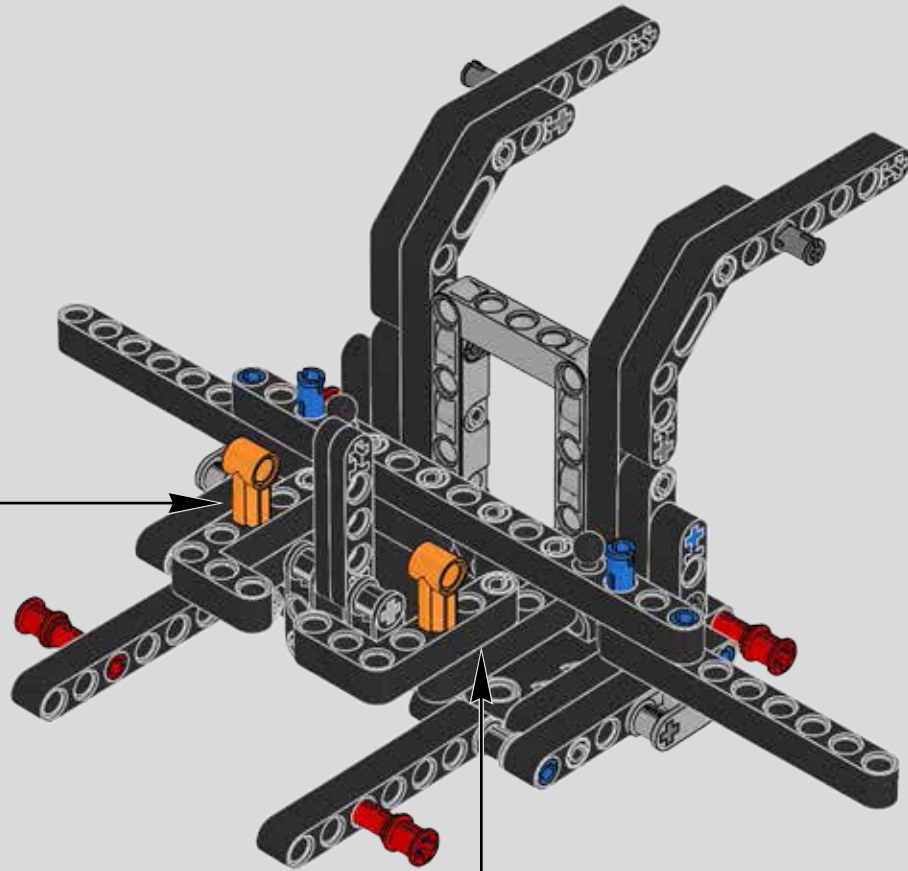
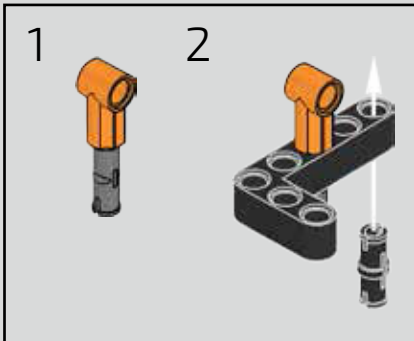

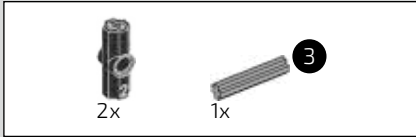

338

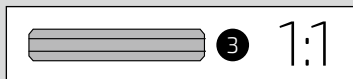
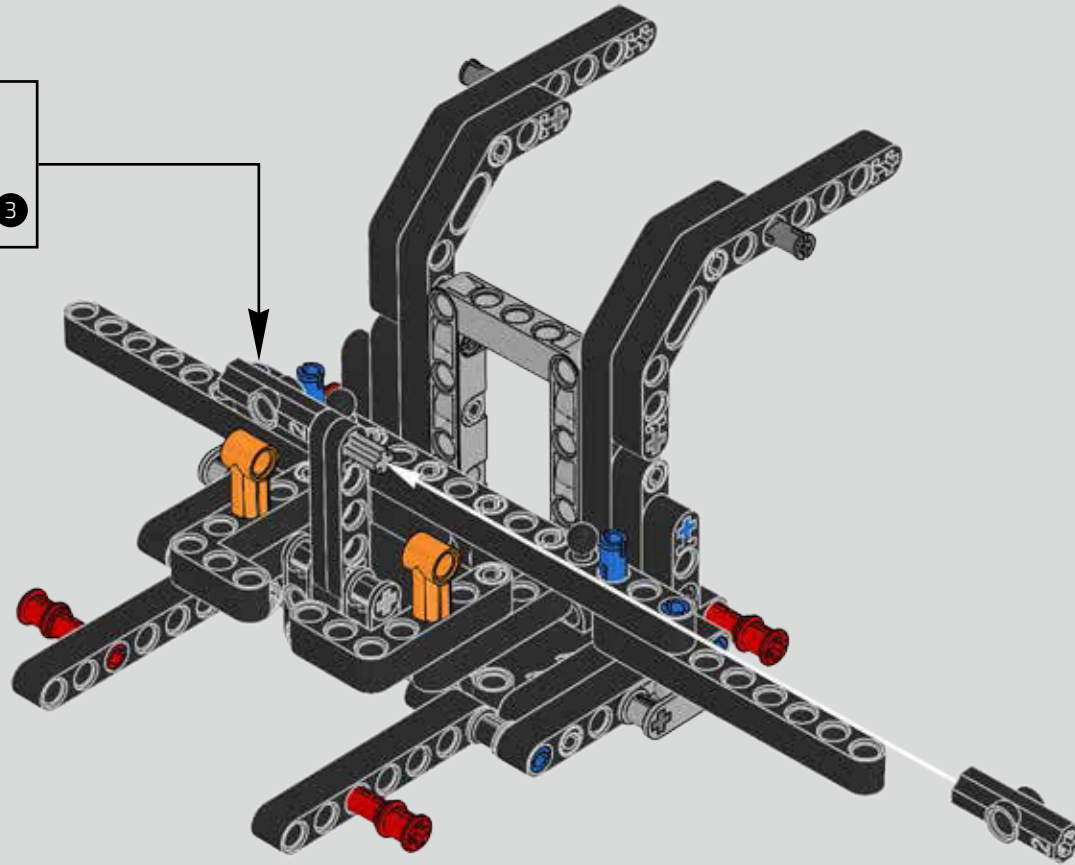
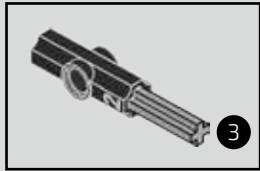

339

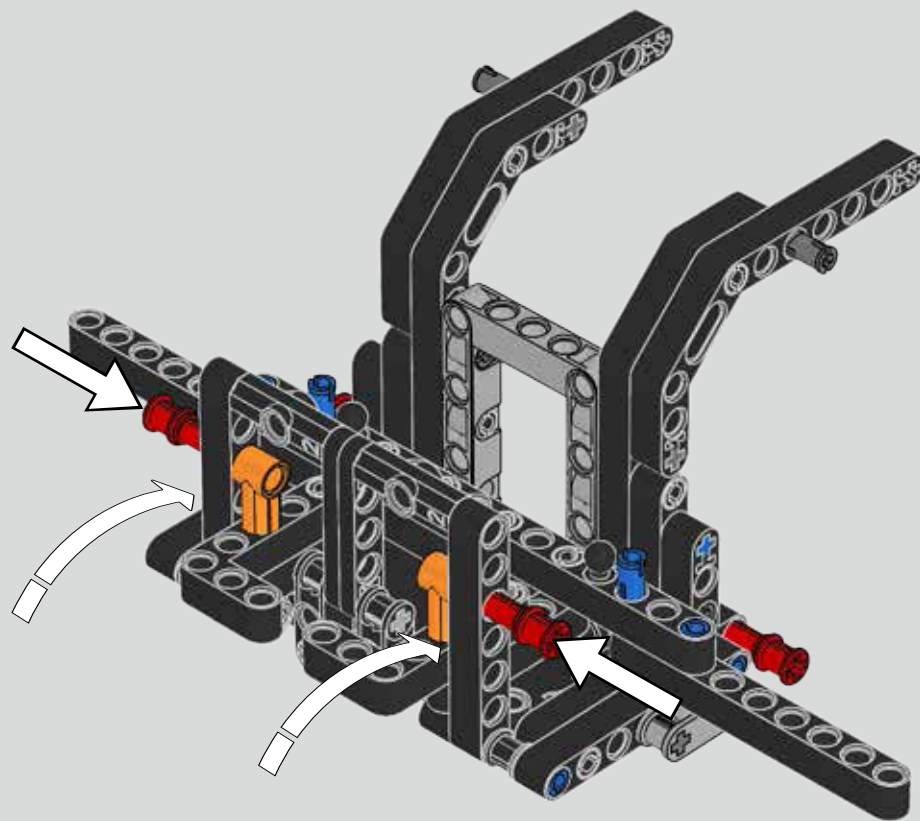

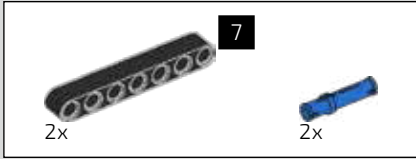

340

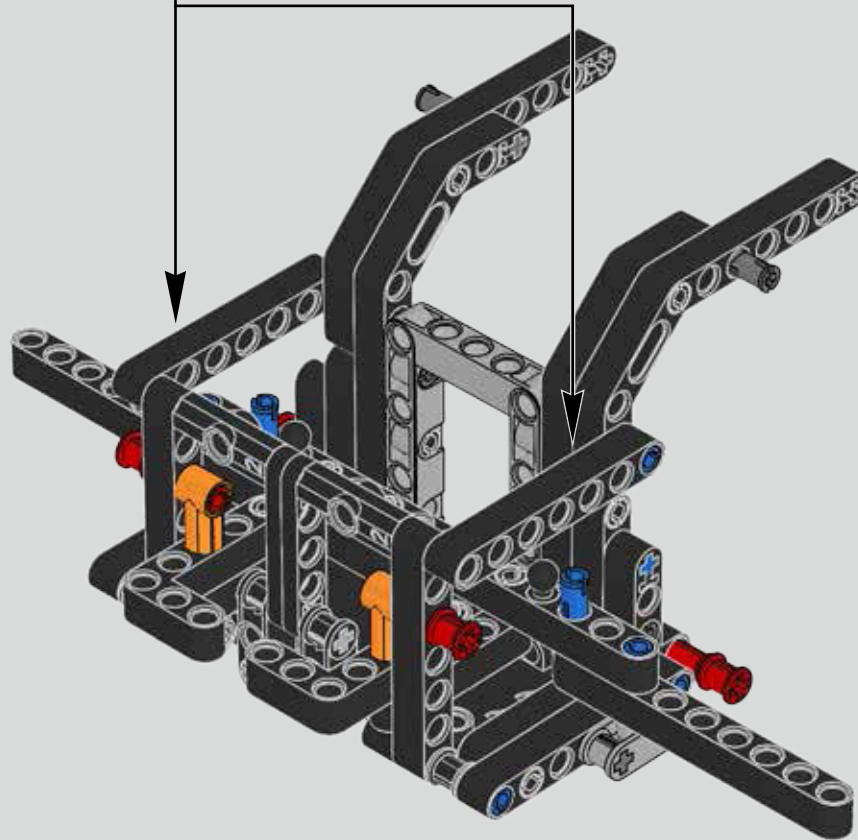
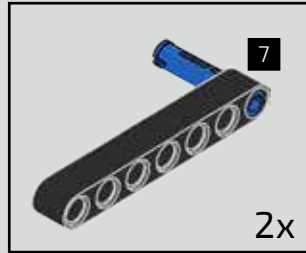

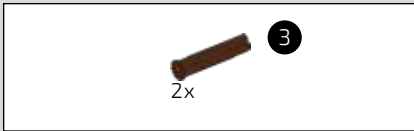

341

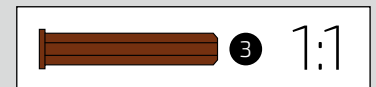
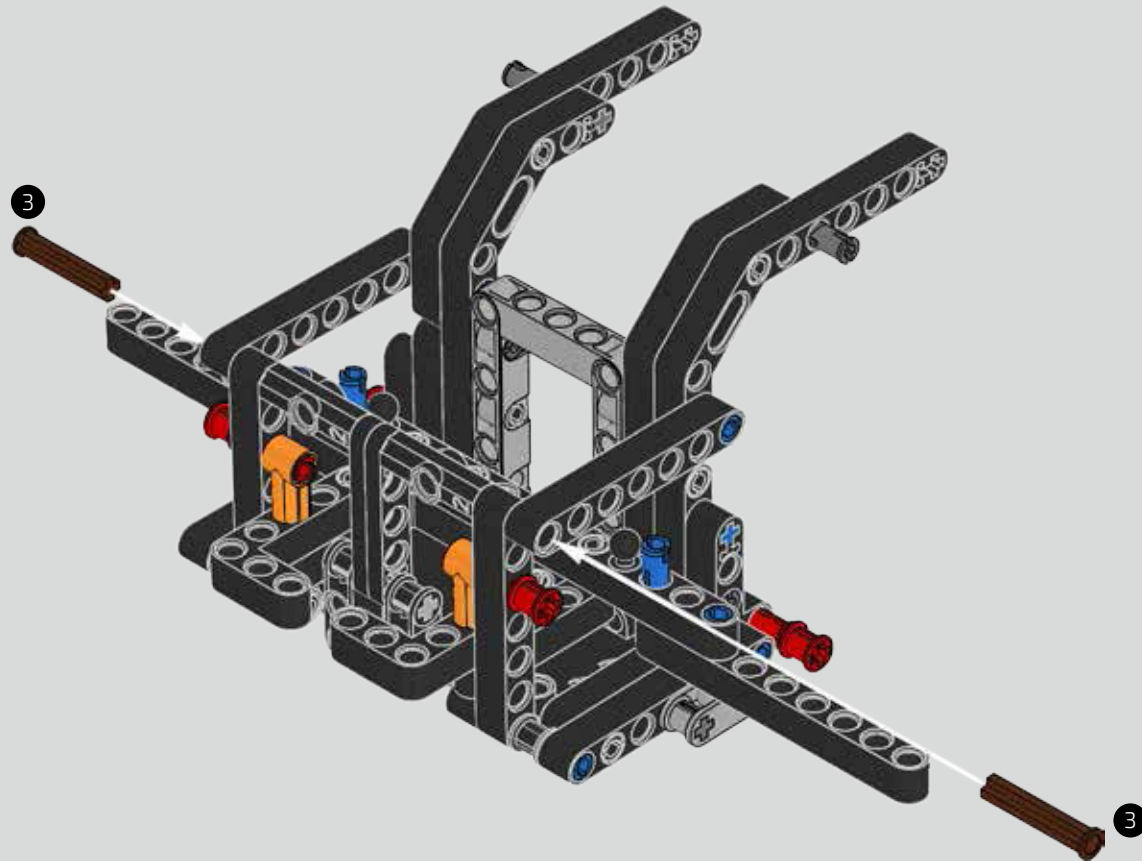

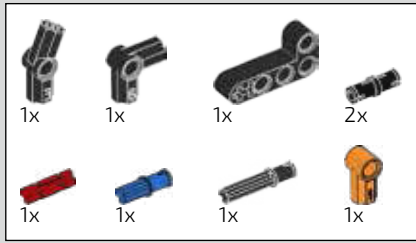

342

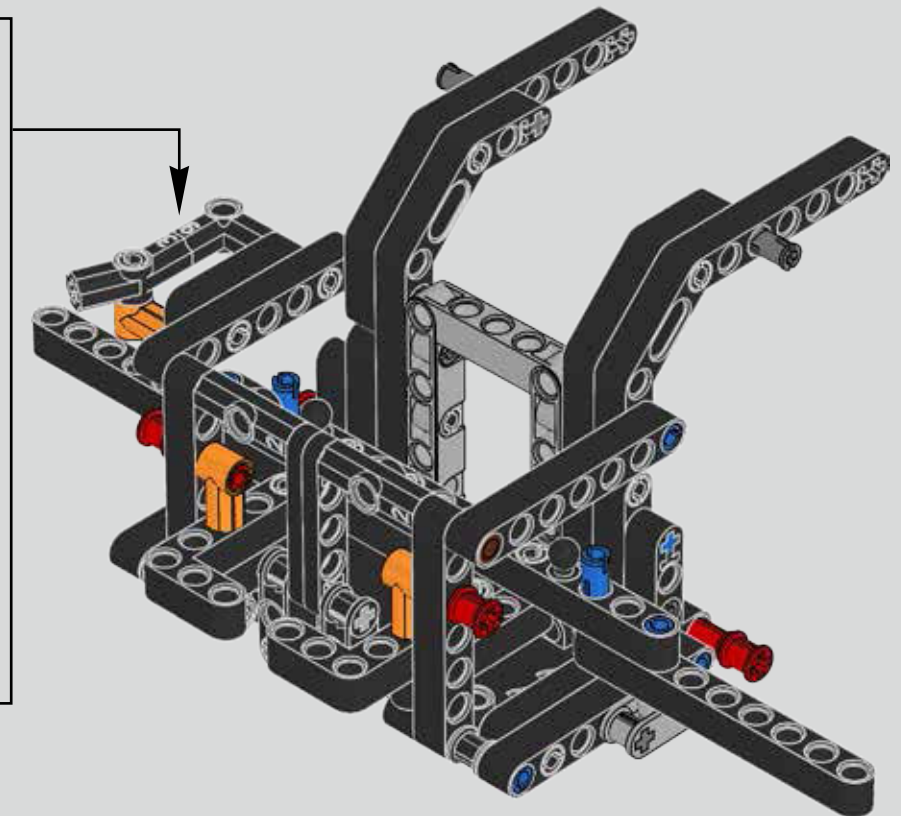
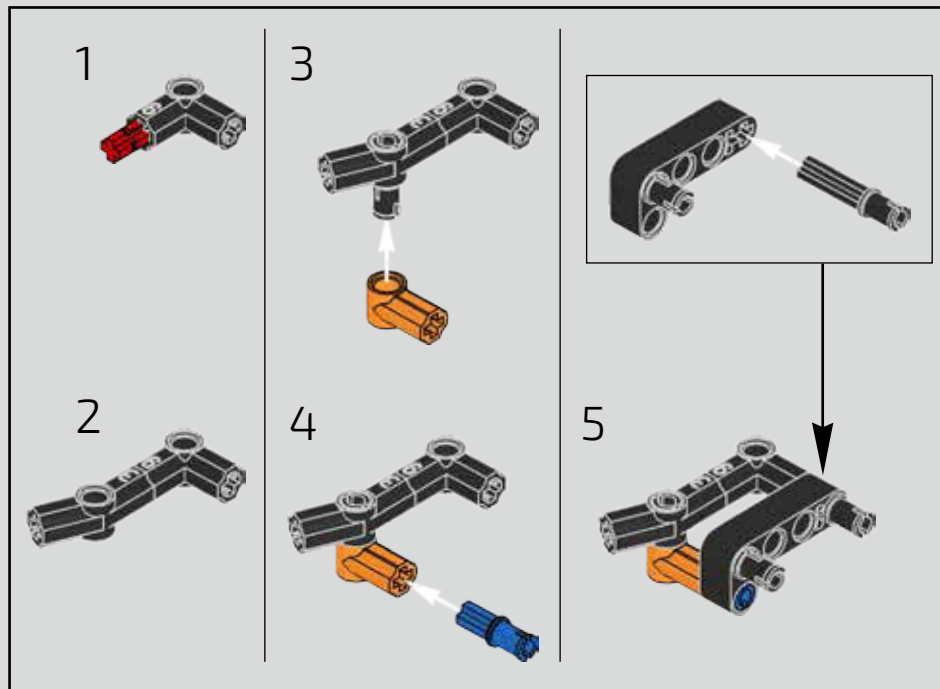

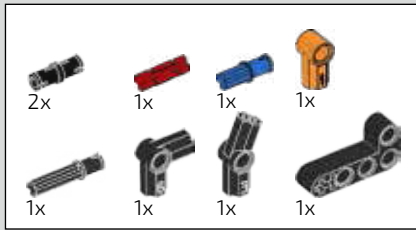

343

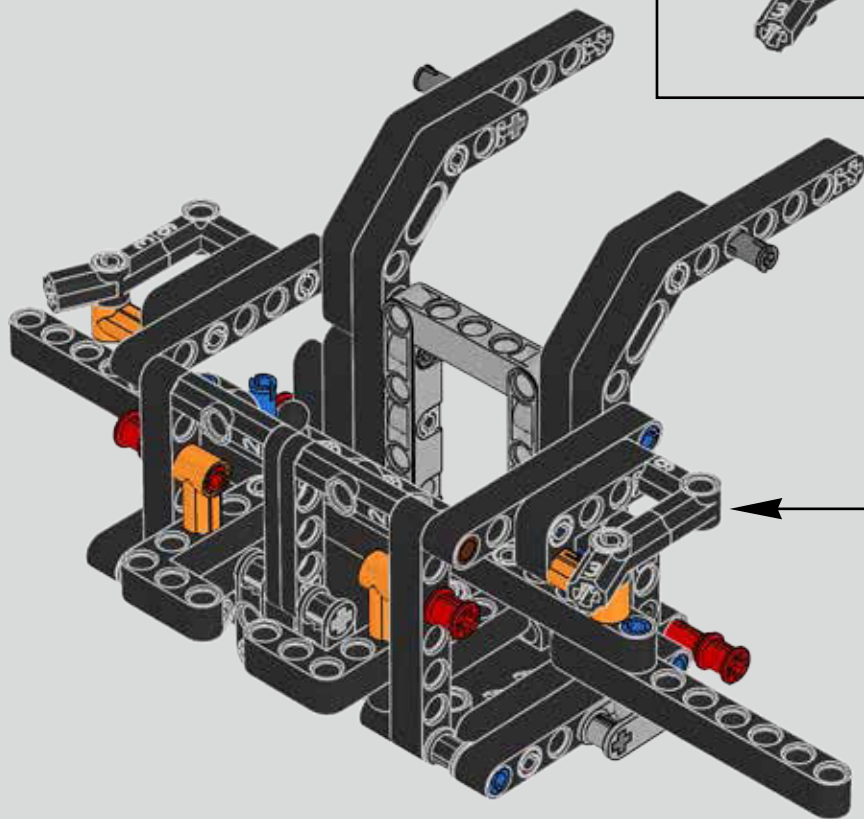
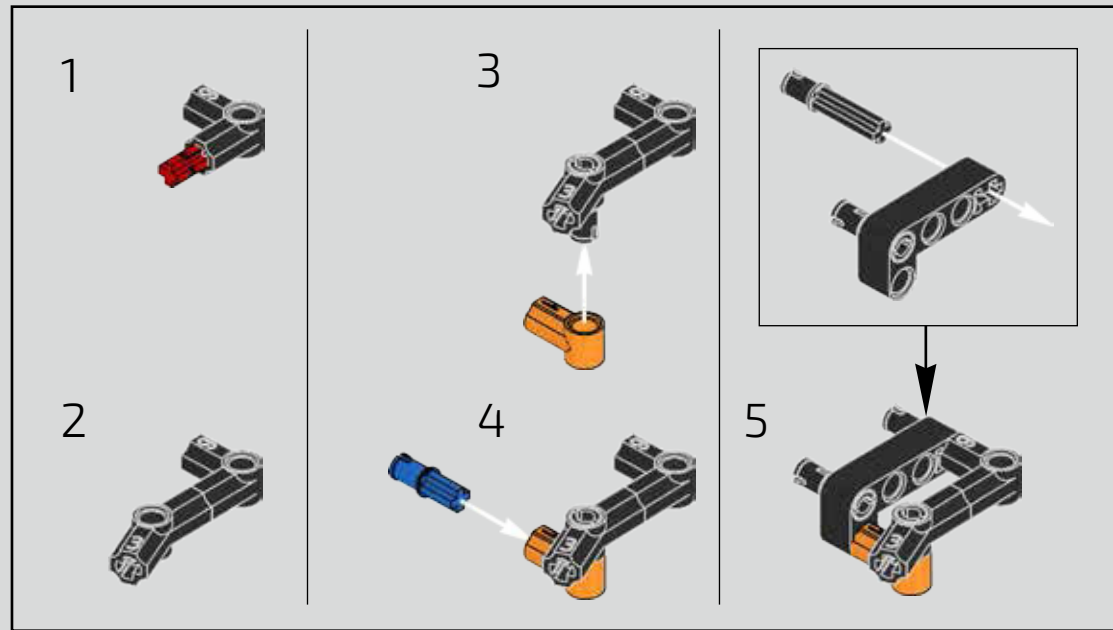

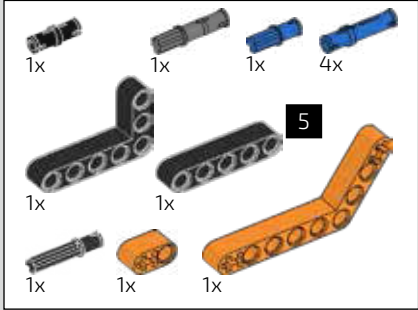
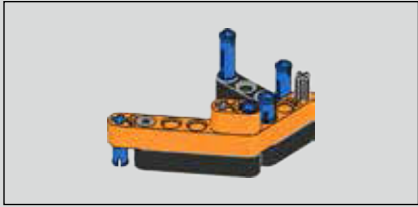

344

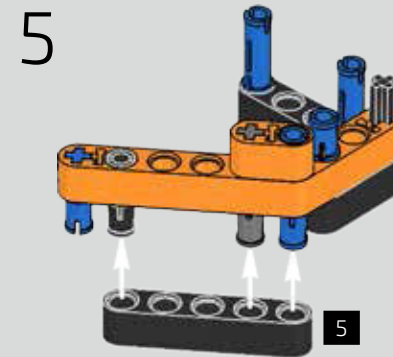
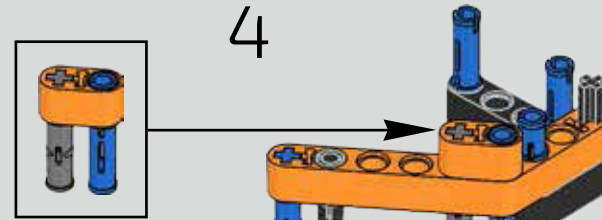
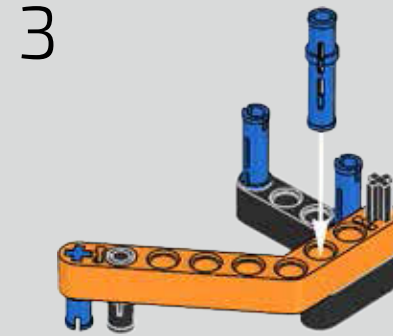
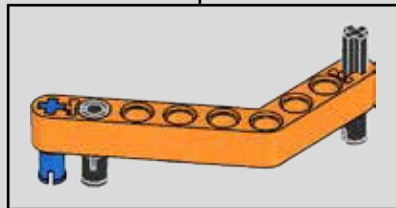
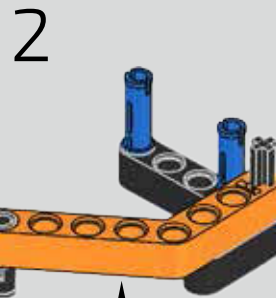
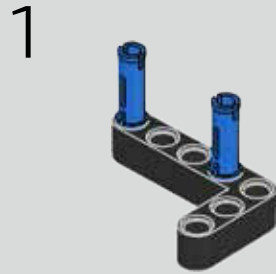

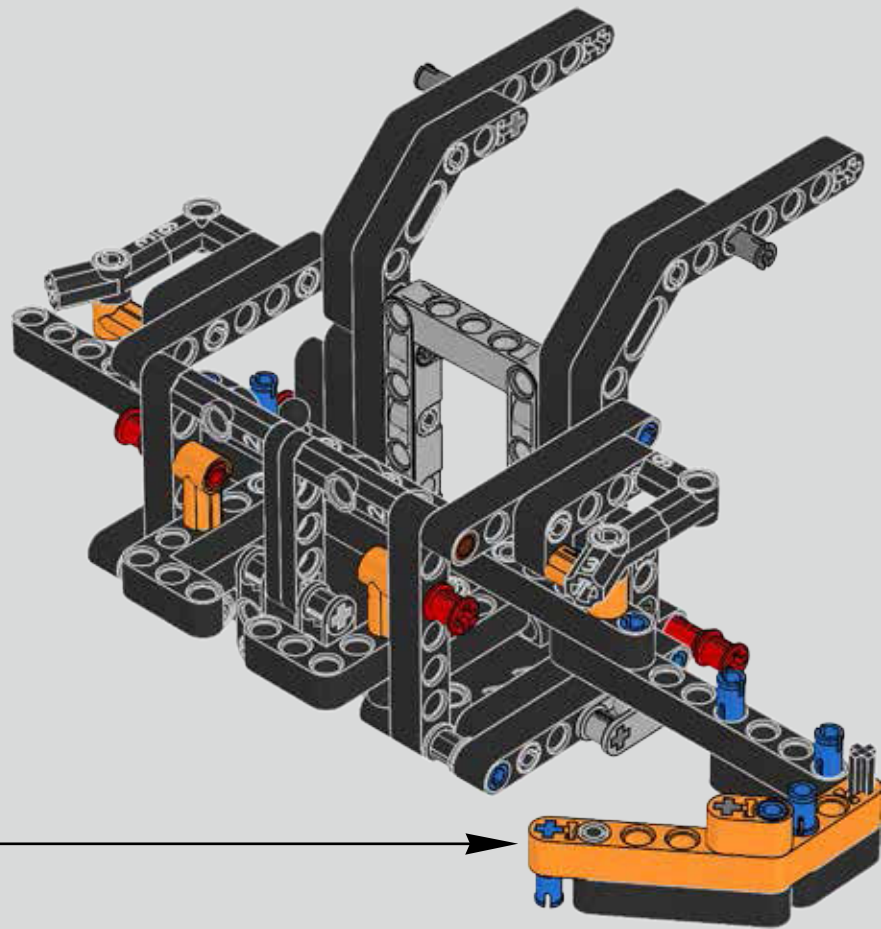

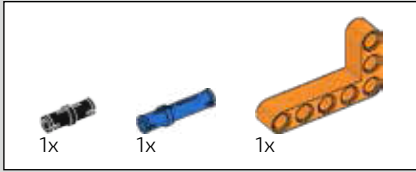

345

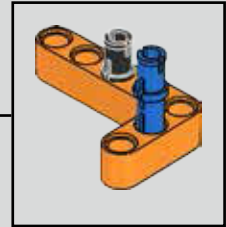
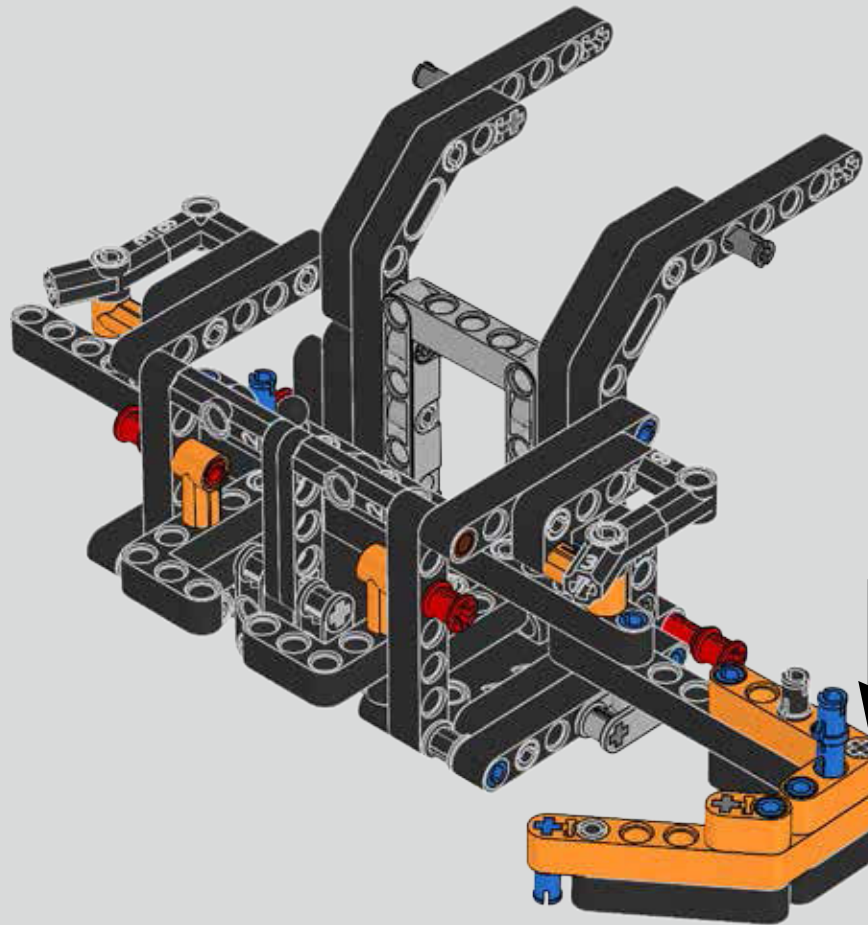

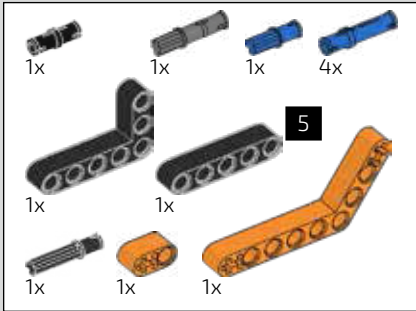

346

1

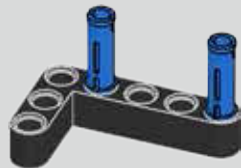

2

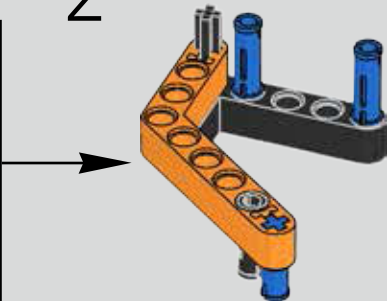
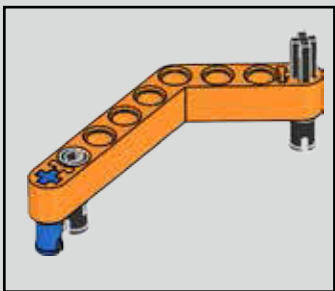

3

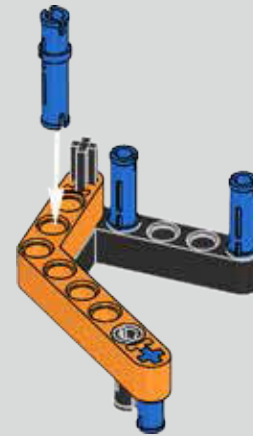

4

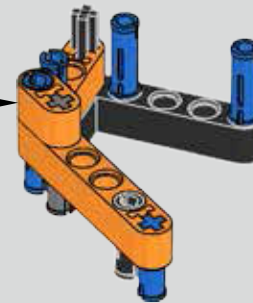
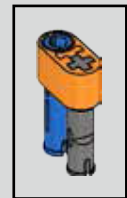

5

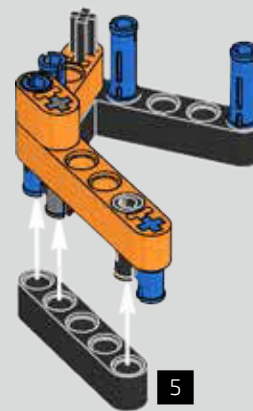

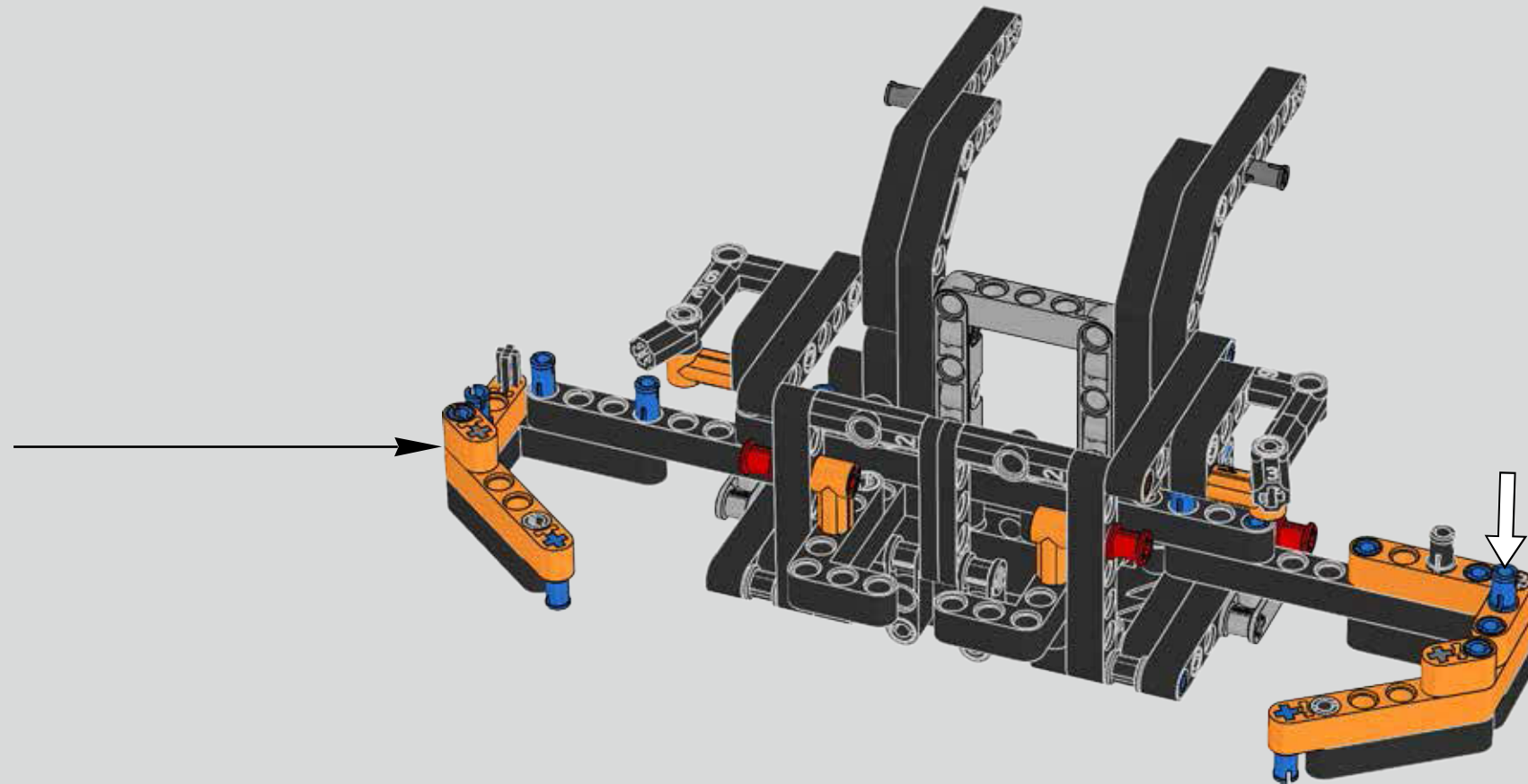

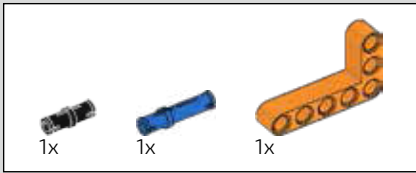

347

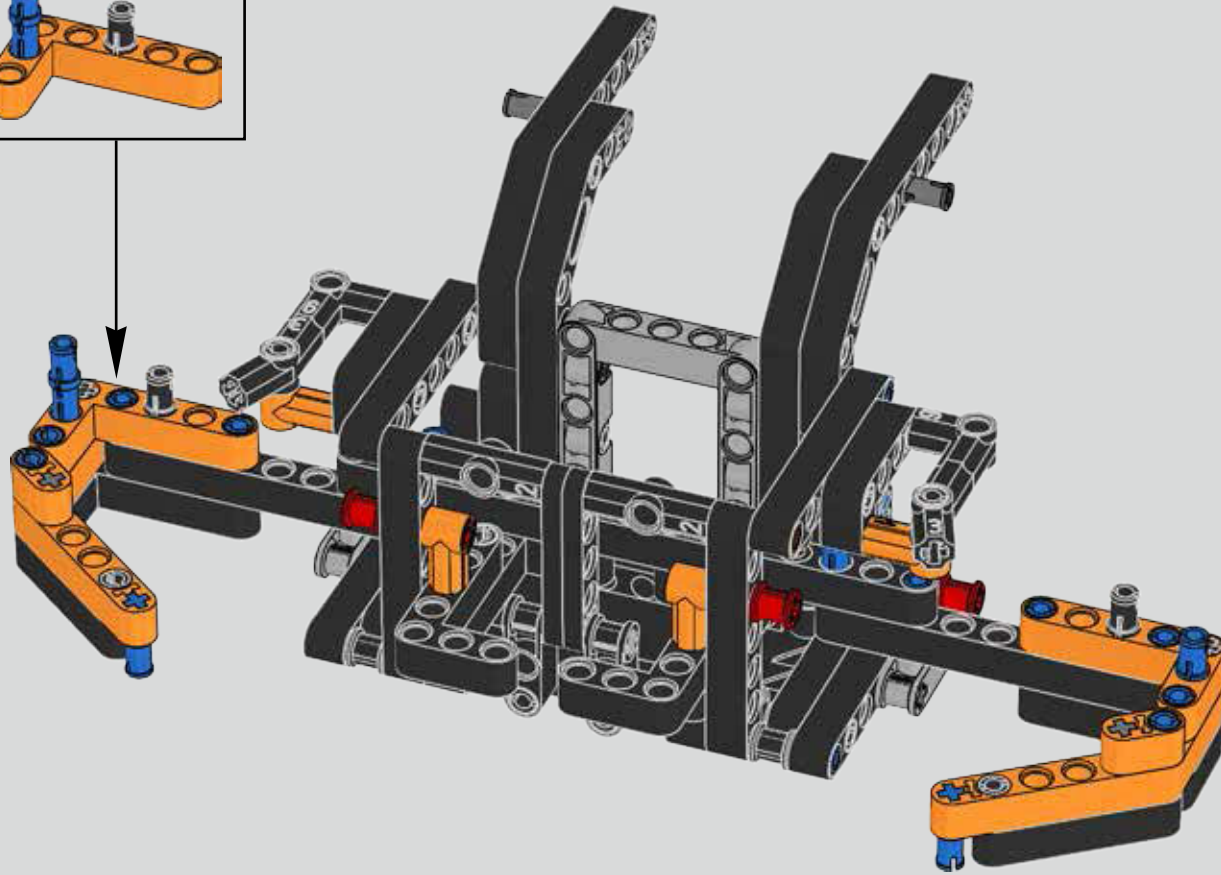
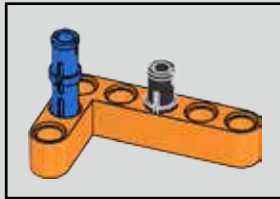

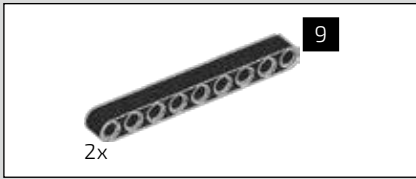

348

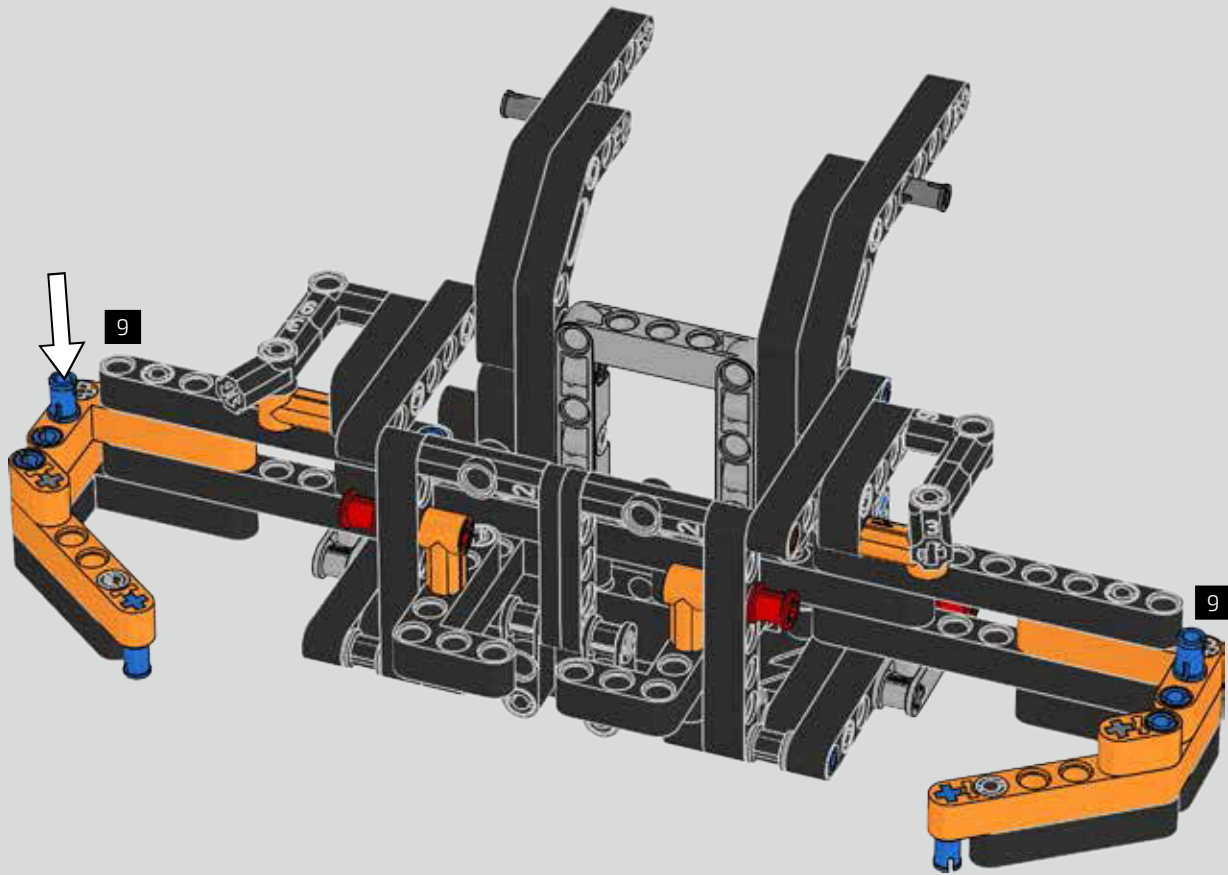

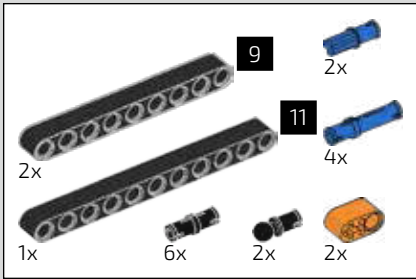

349

1

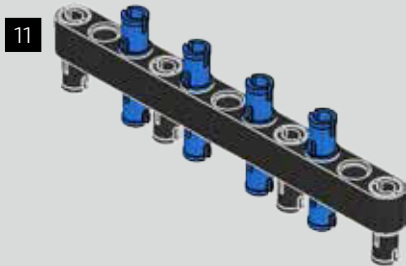

2

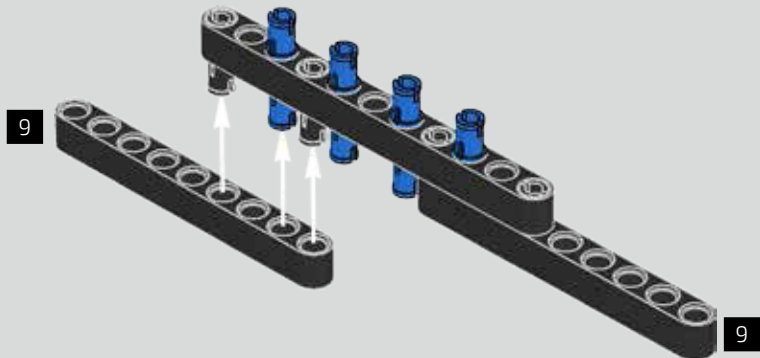

3

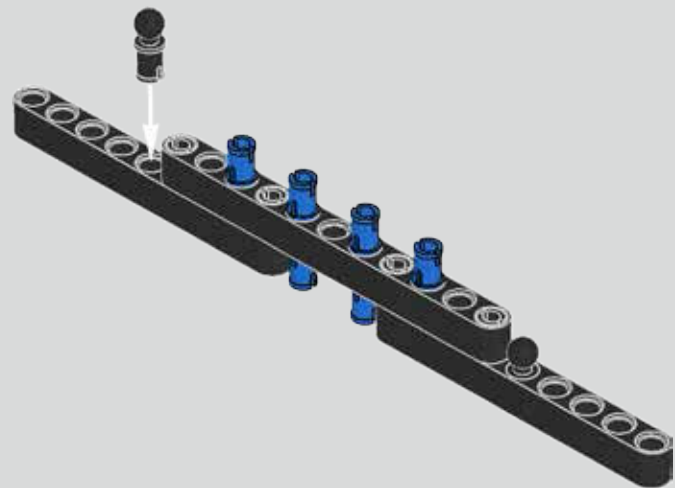

4

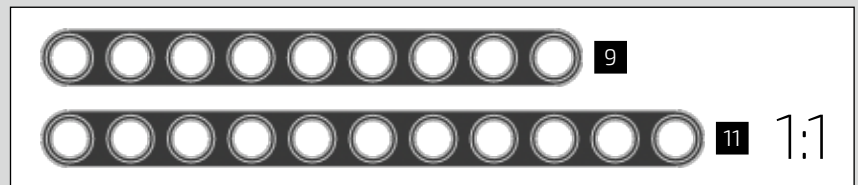
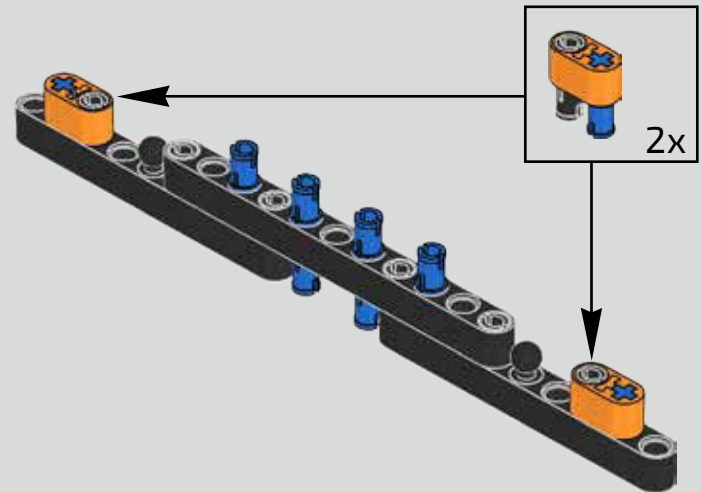

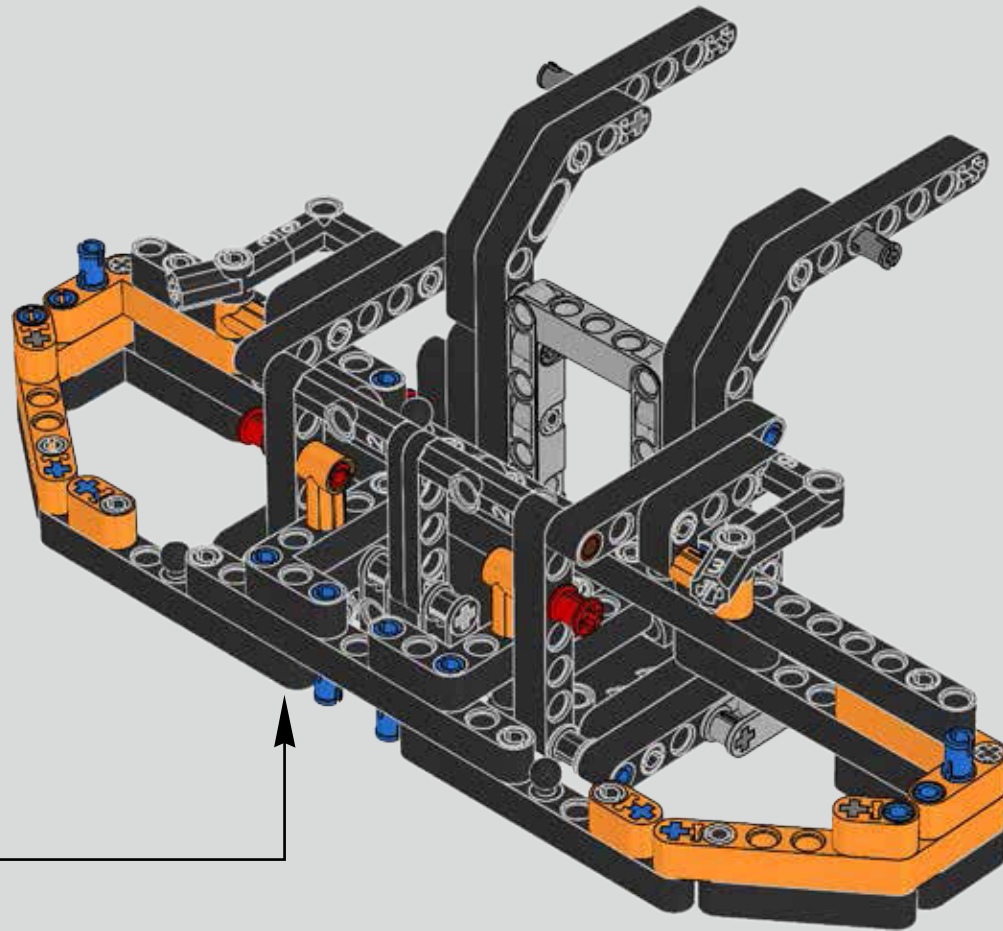

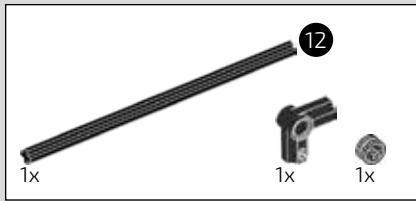

350

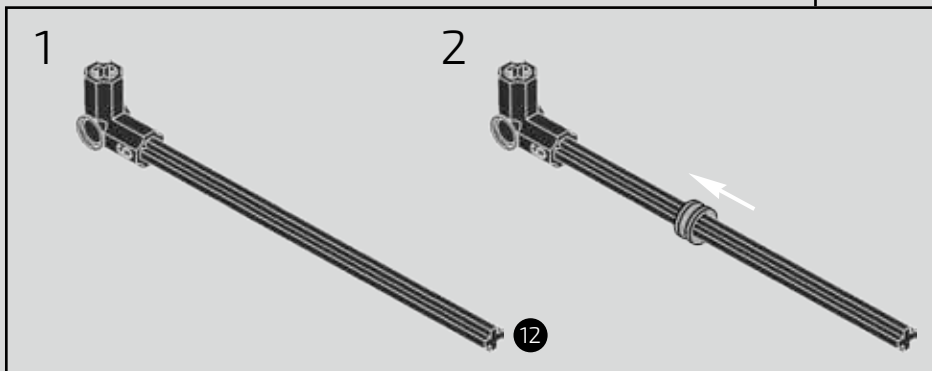
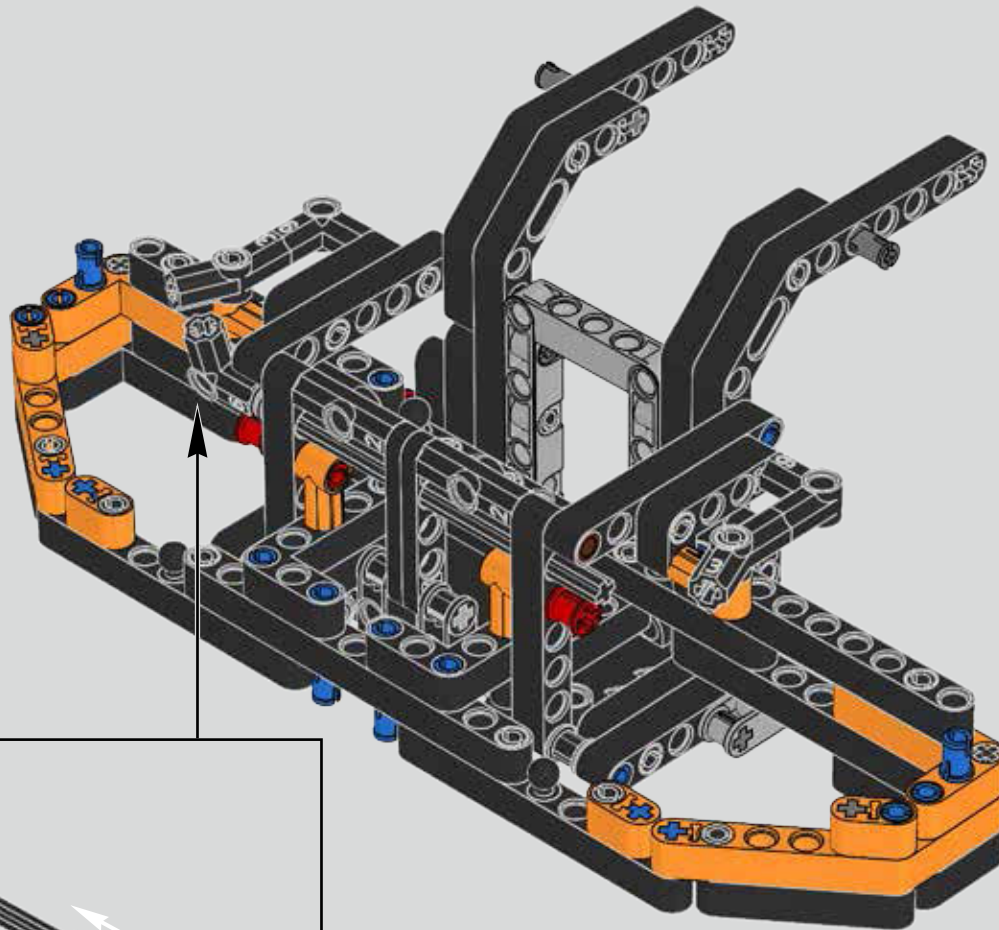



351

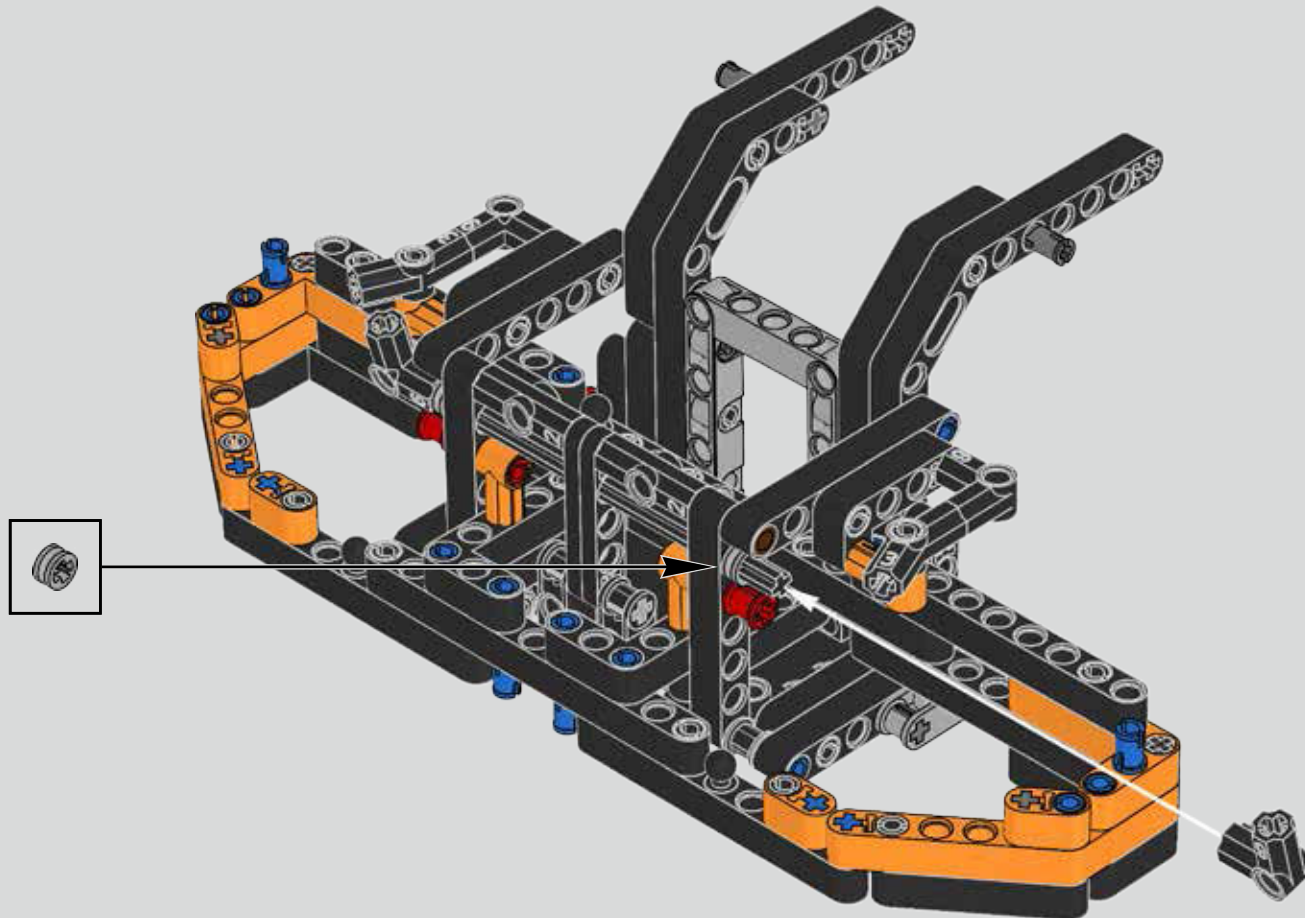

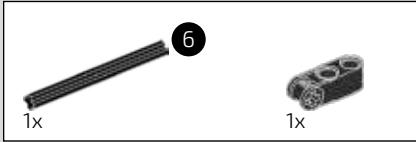
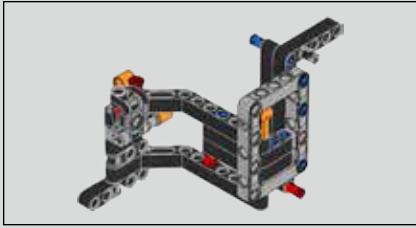

352



353

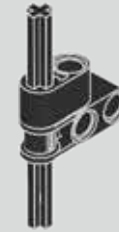

354



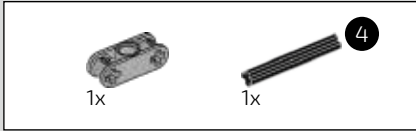

355

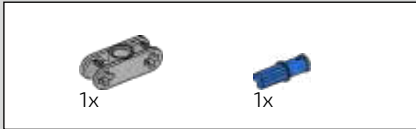
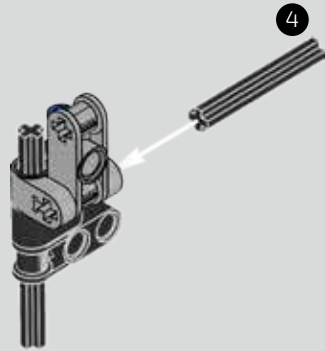

356

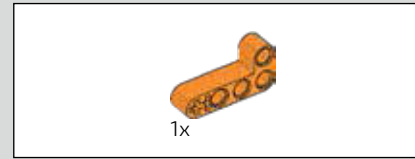
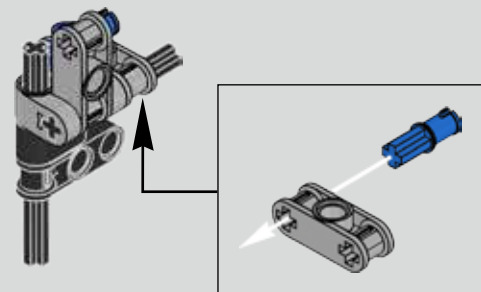

357

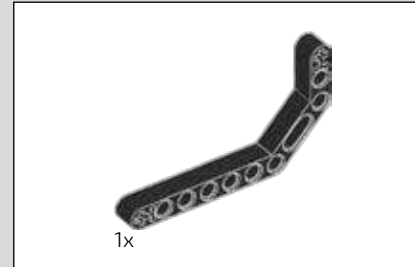
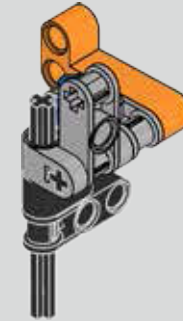

358

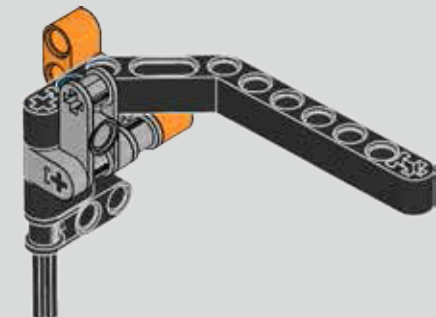

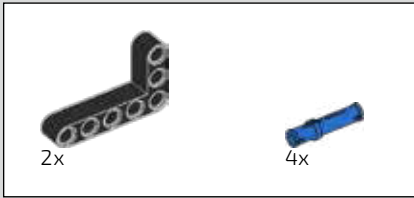

359

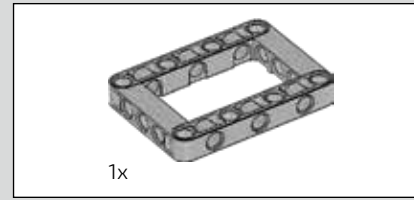
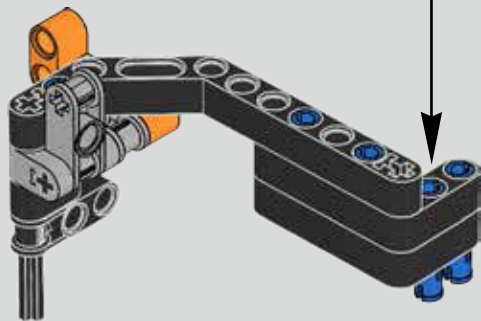
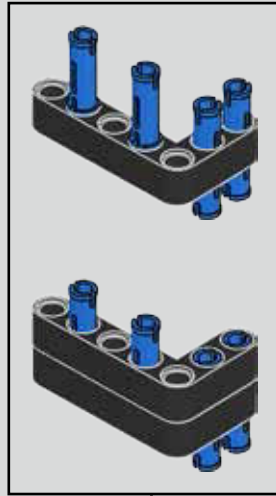

360

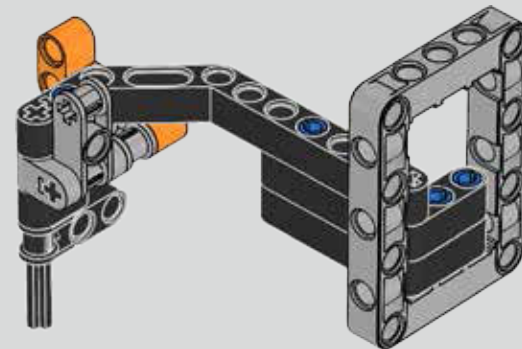



361

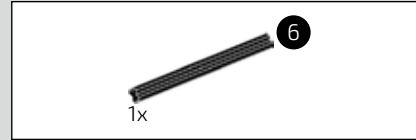
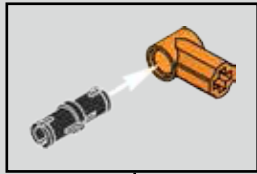
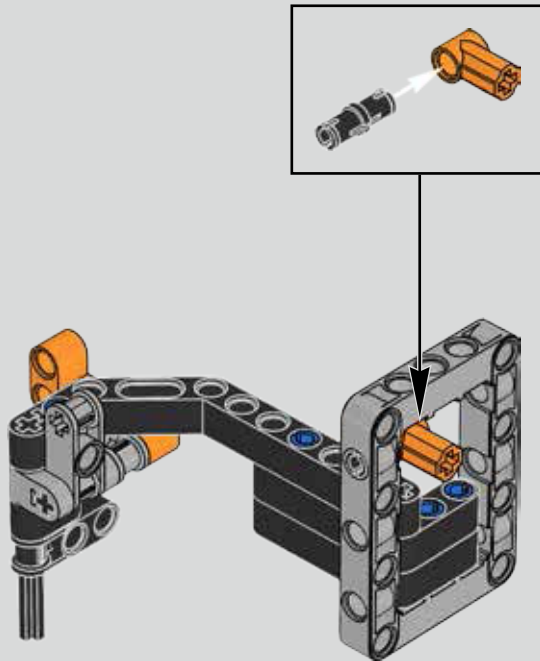

362

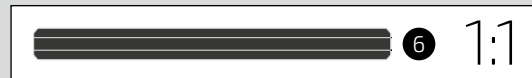
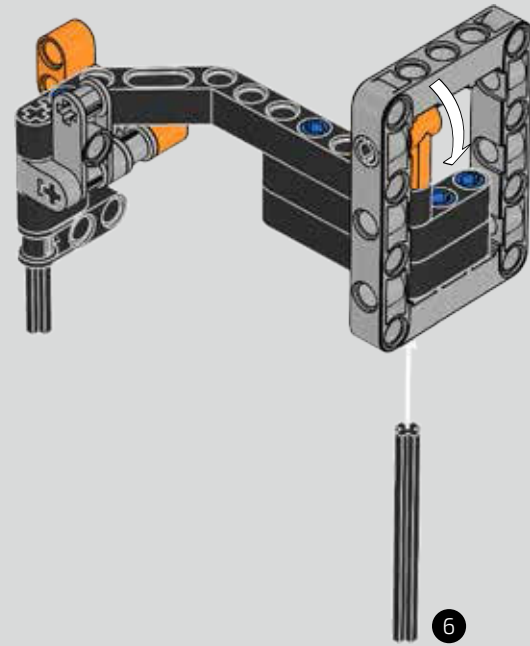

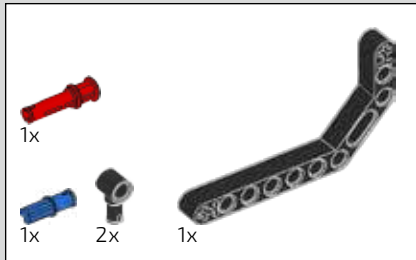

363

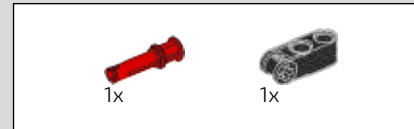
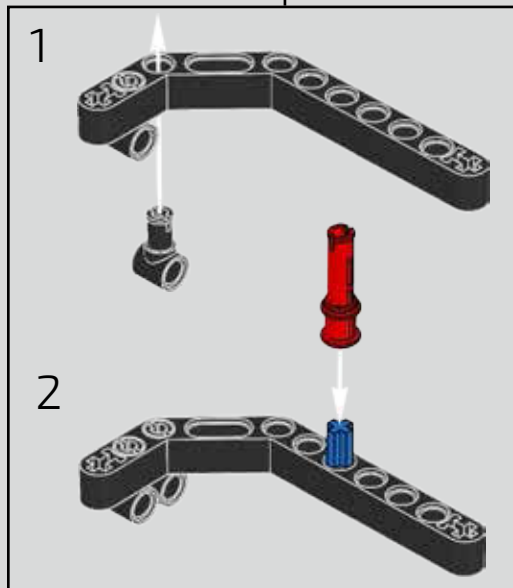
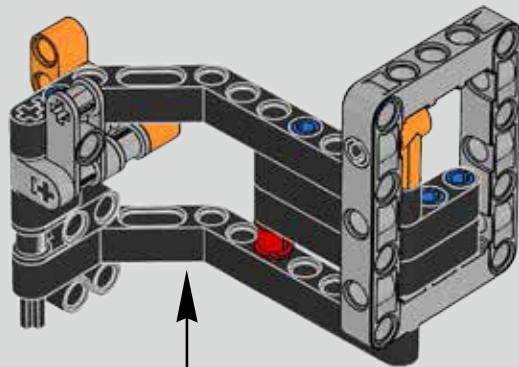

364

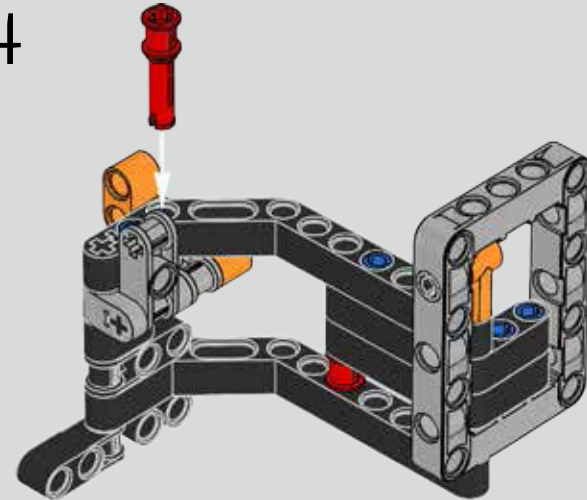

365

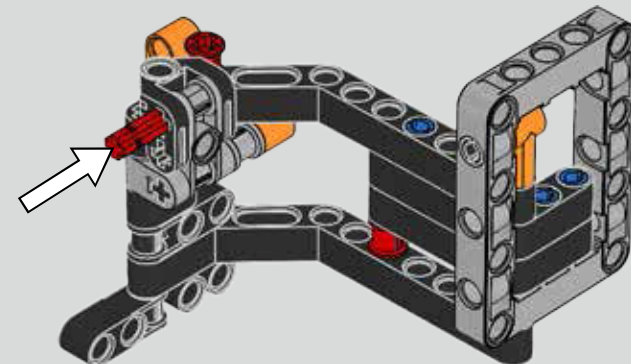

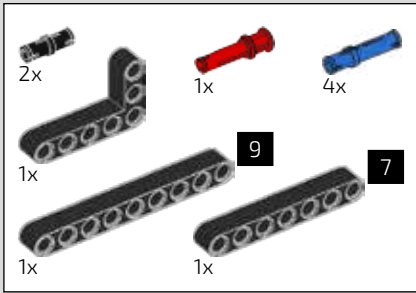

366

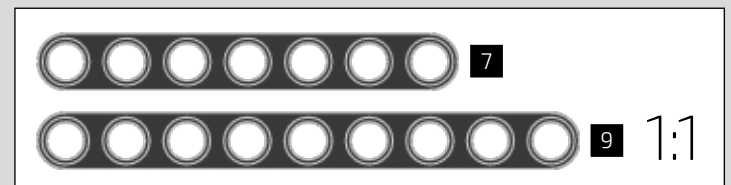
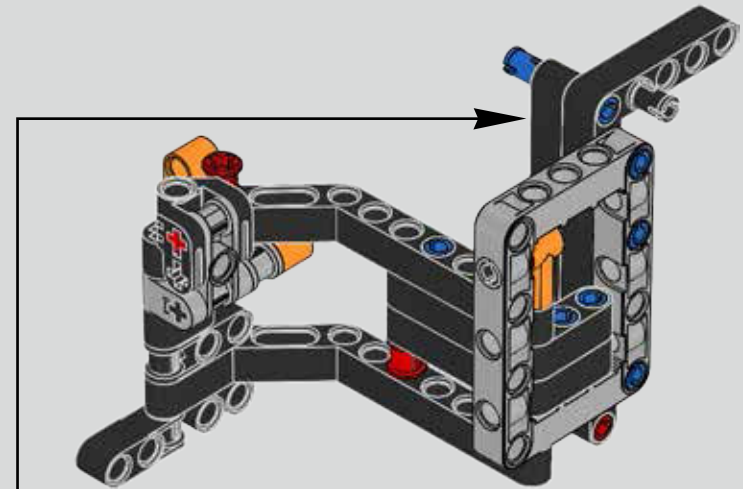
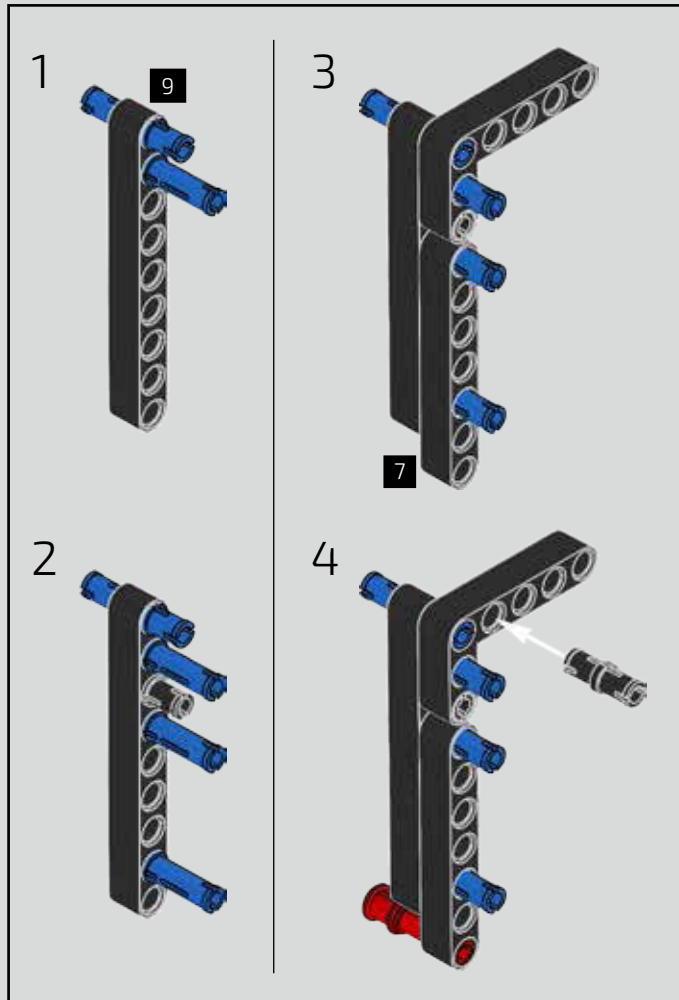

367

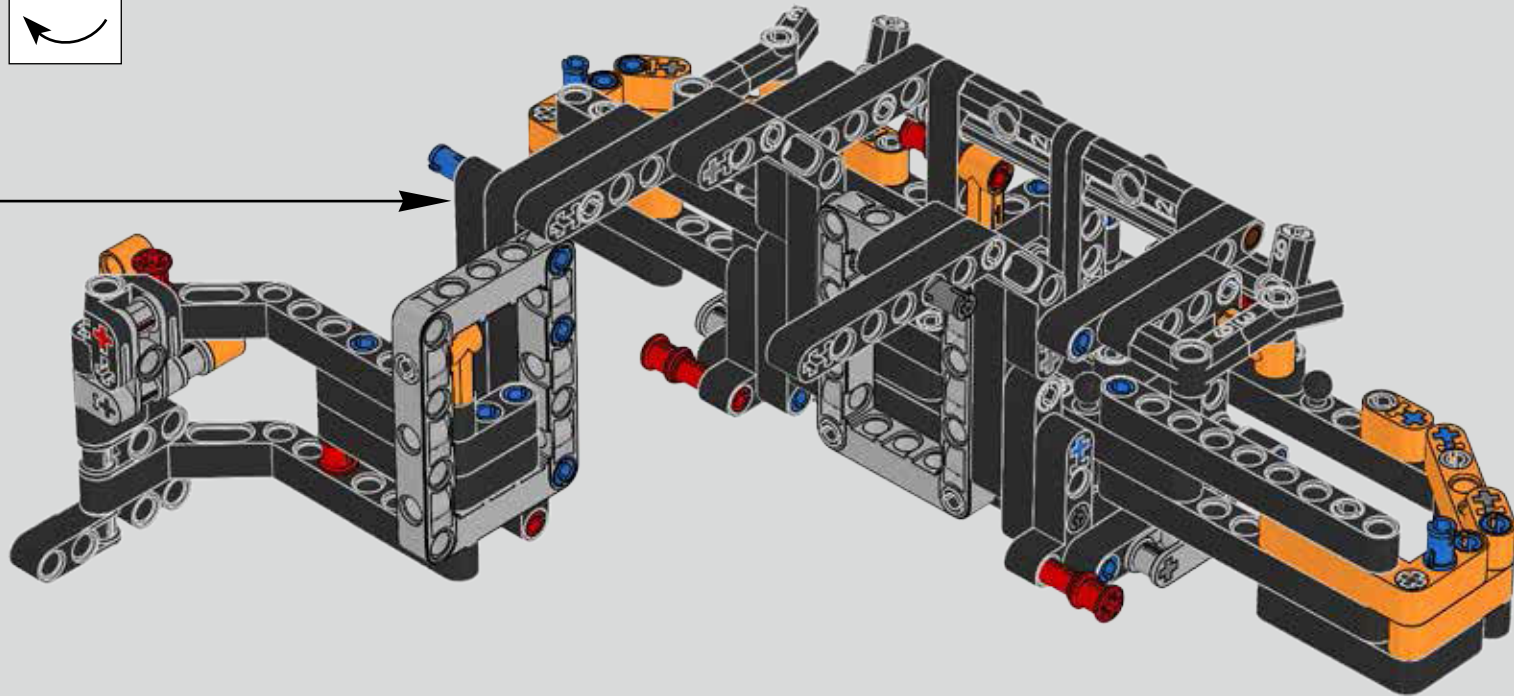
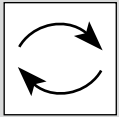

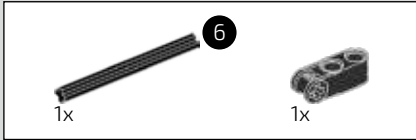
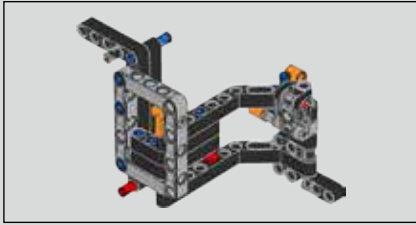

368

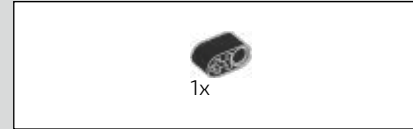
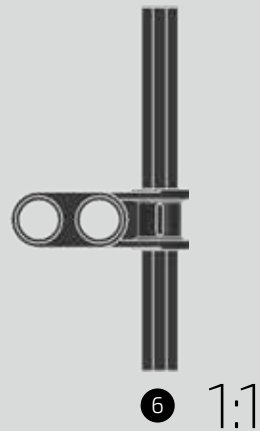

369

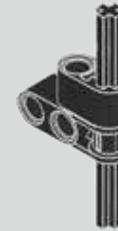

370



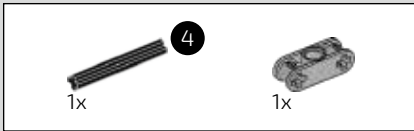

371

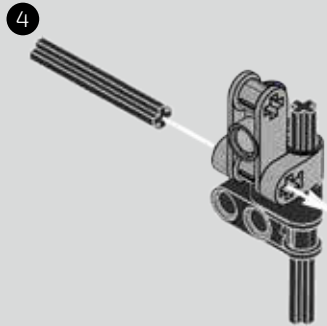

372

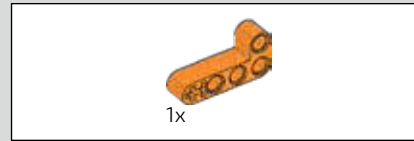
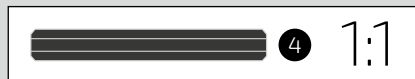
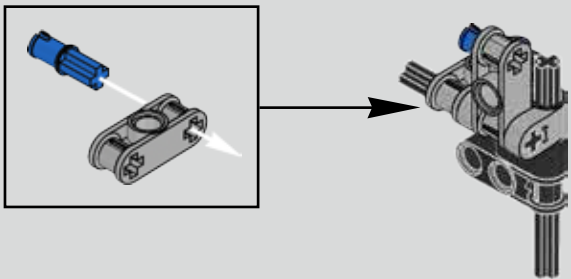

373

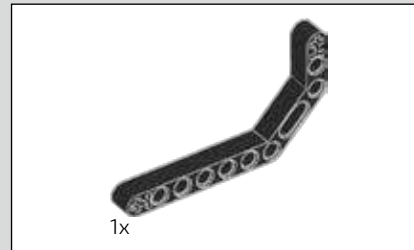
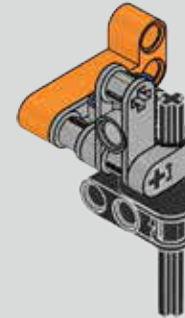

374

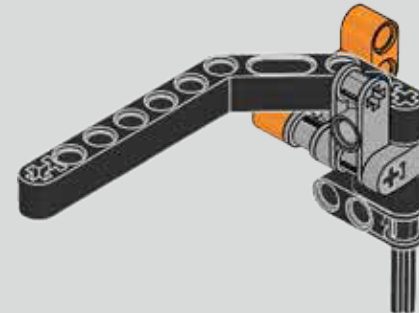

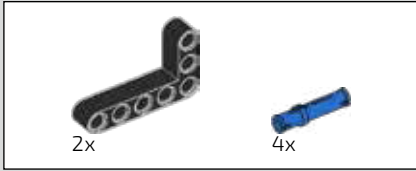

375

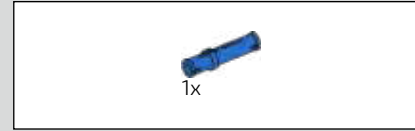
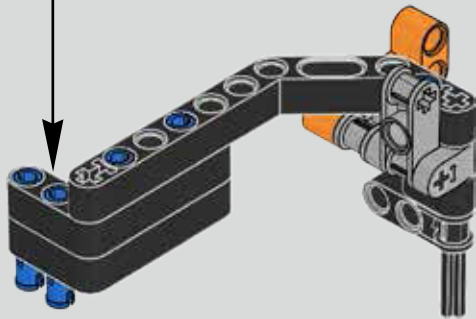
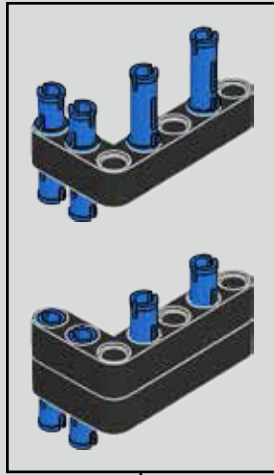

376

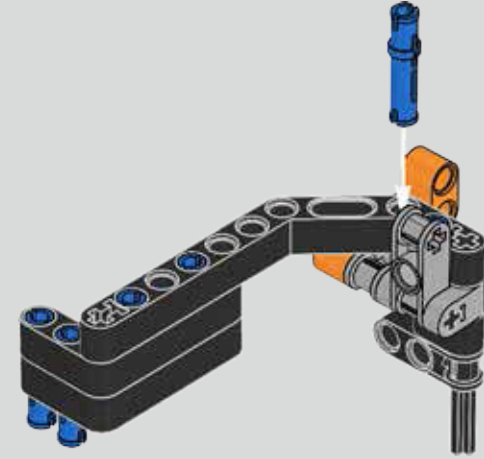

377

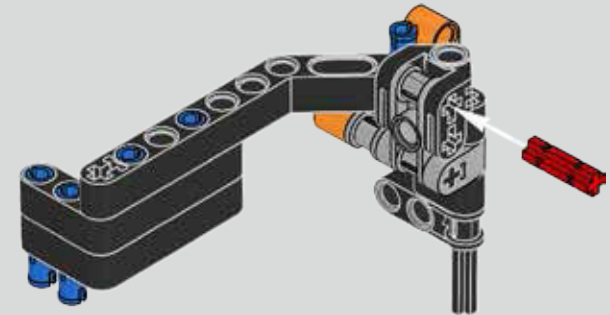

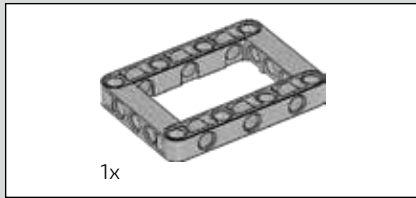

378

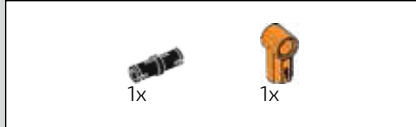
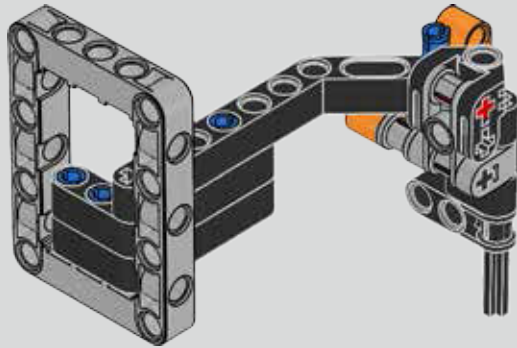

379

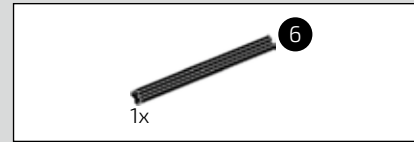
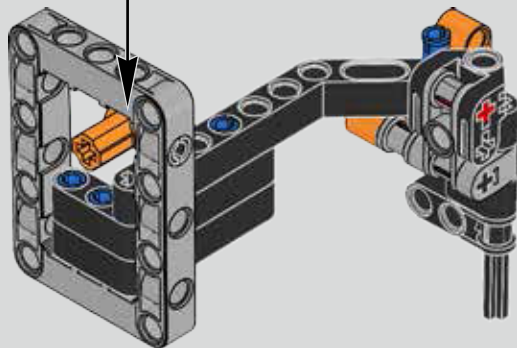
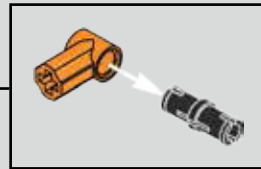

380

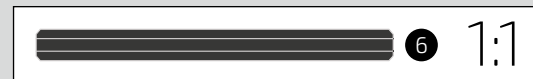
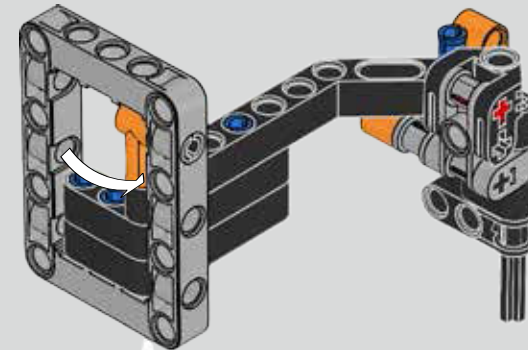

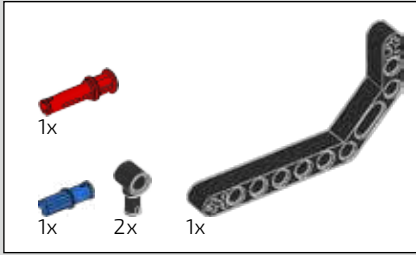

381

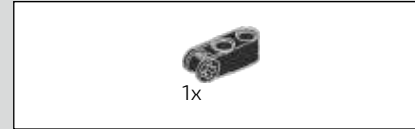
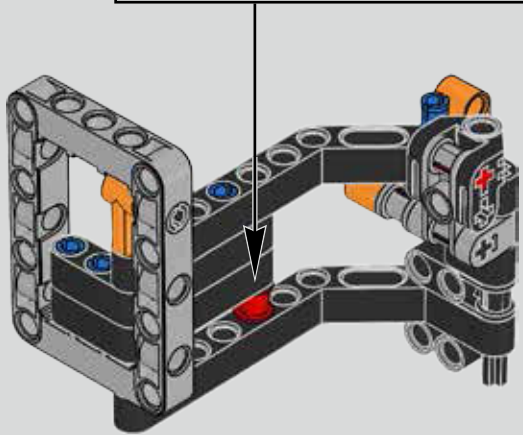
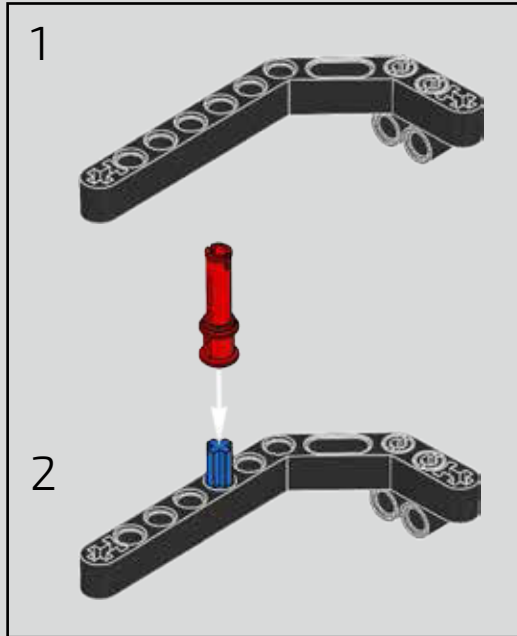

382

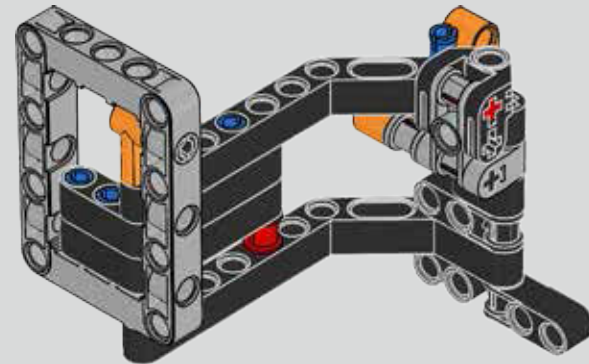

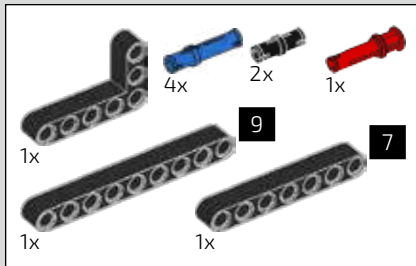

383

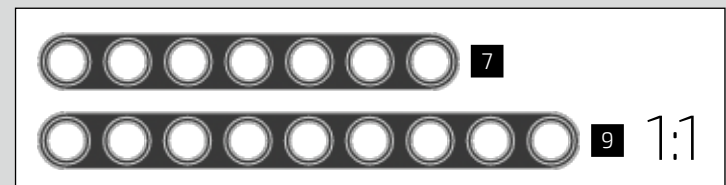
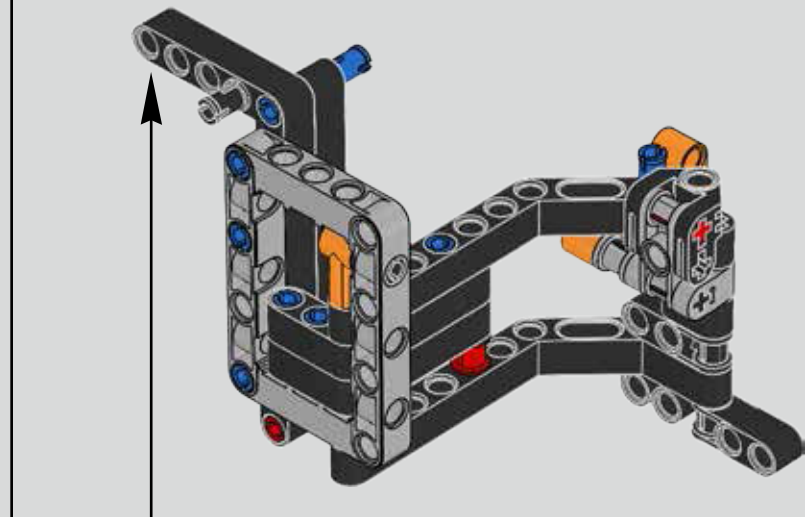
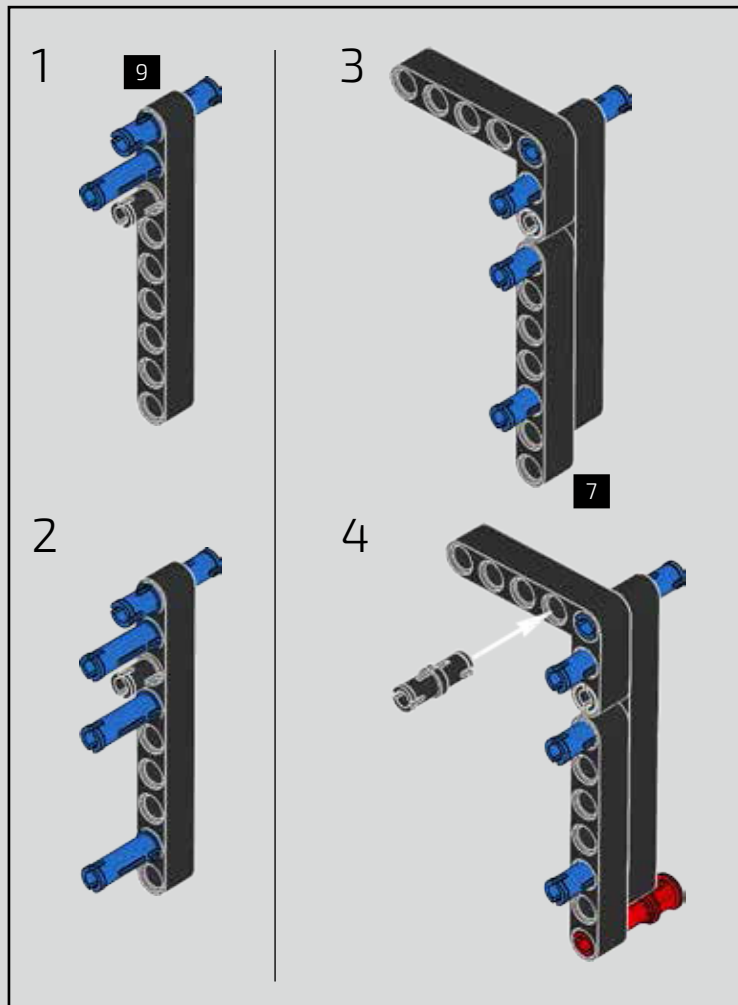

384

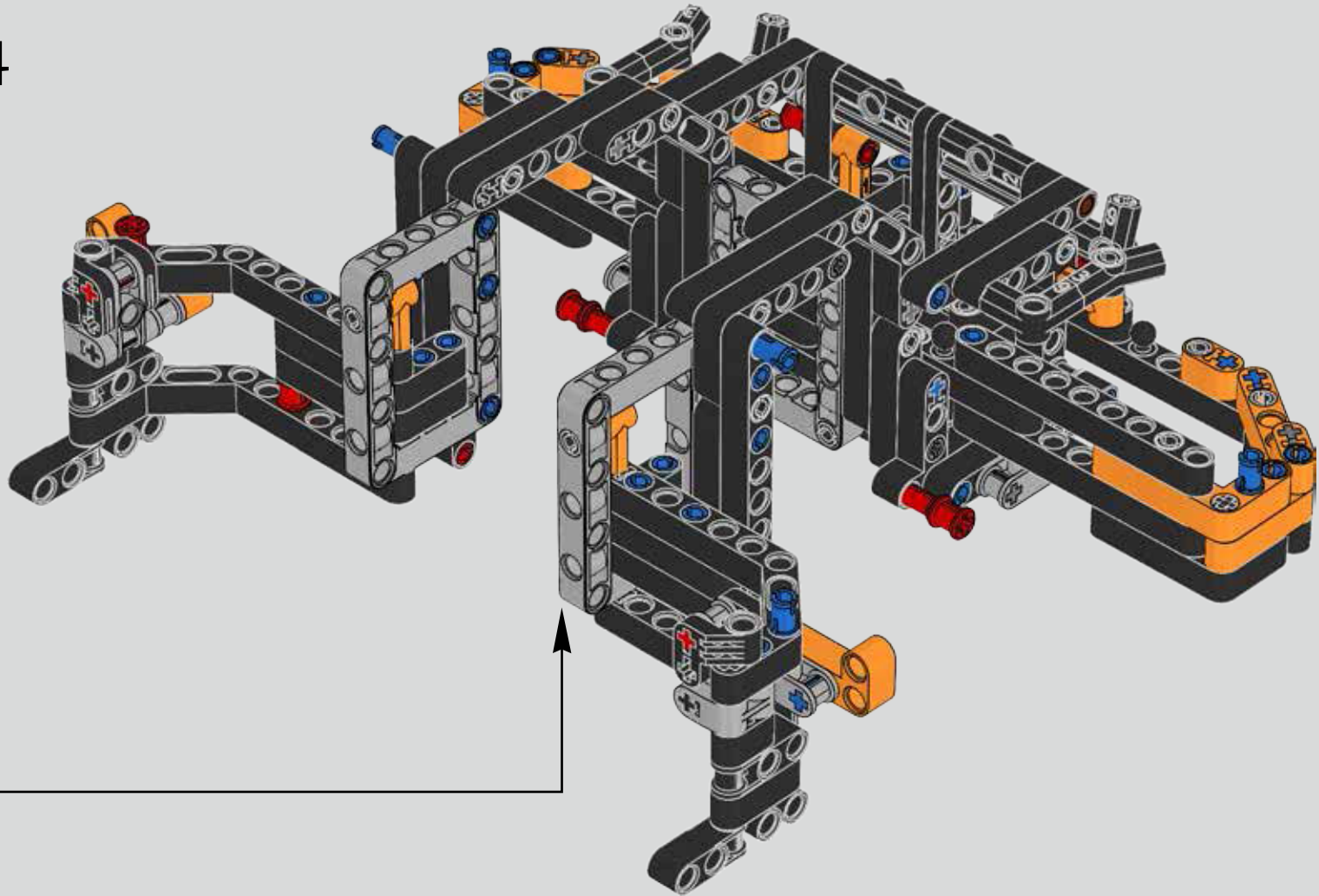



385

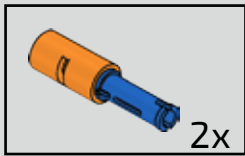
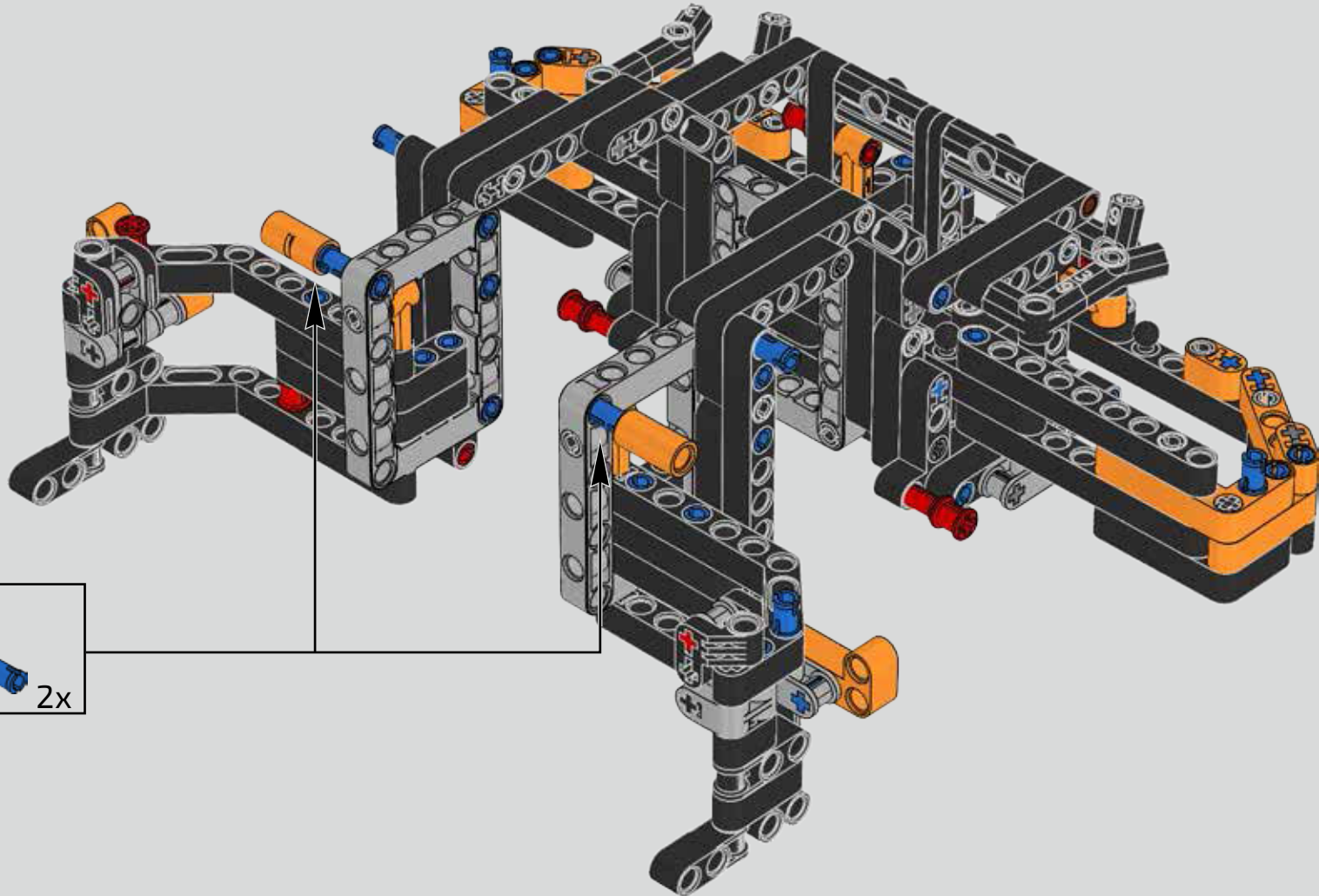

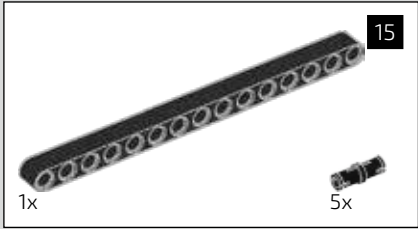
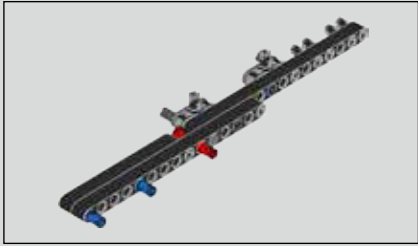

386

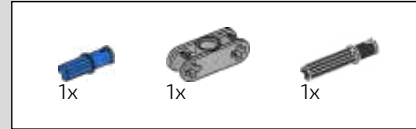
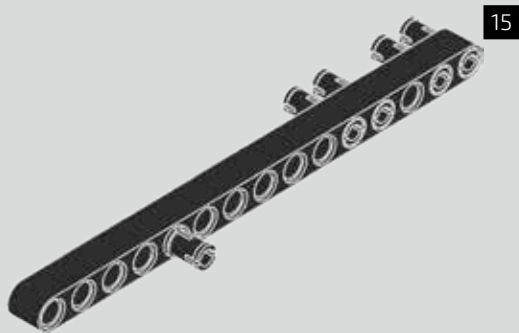

387

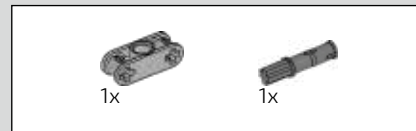
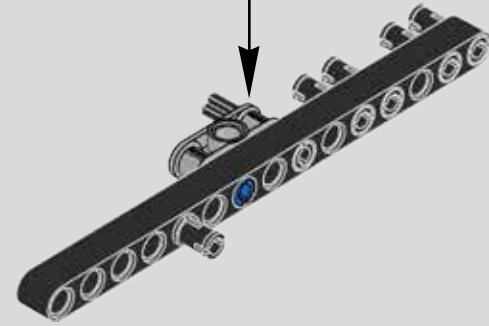
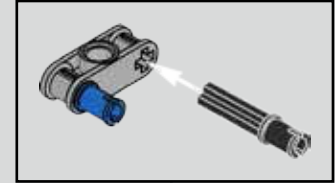

388

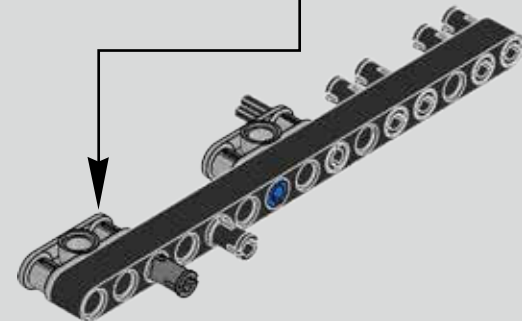
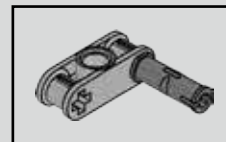

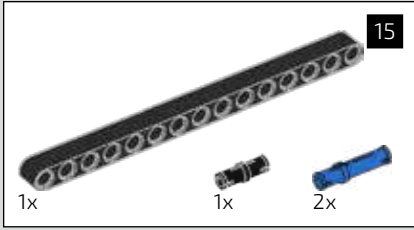

389

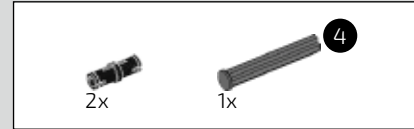
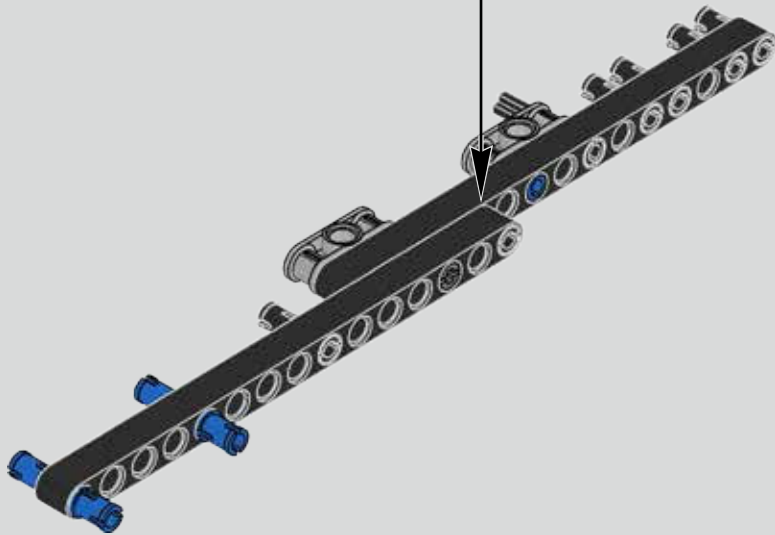
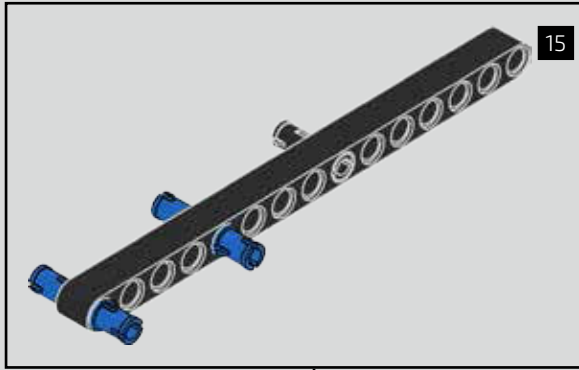

390

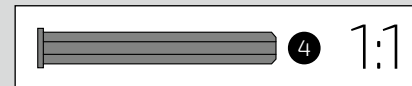
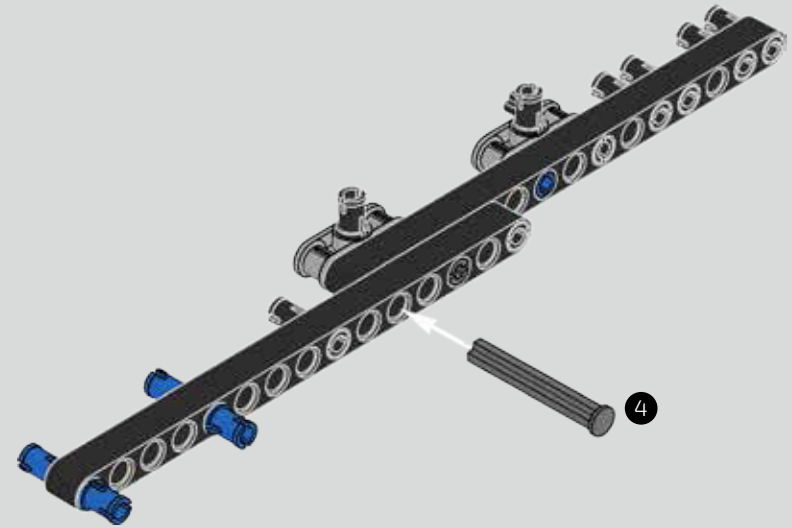

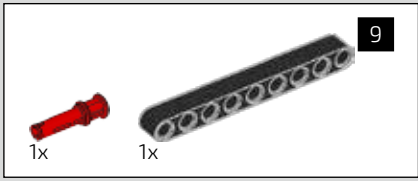

391

9

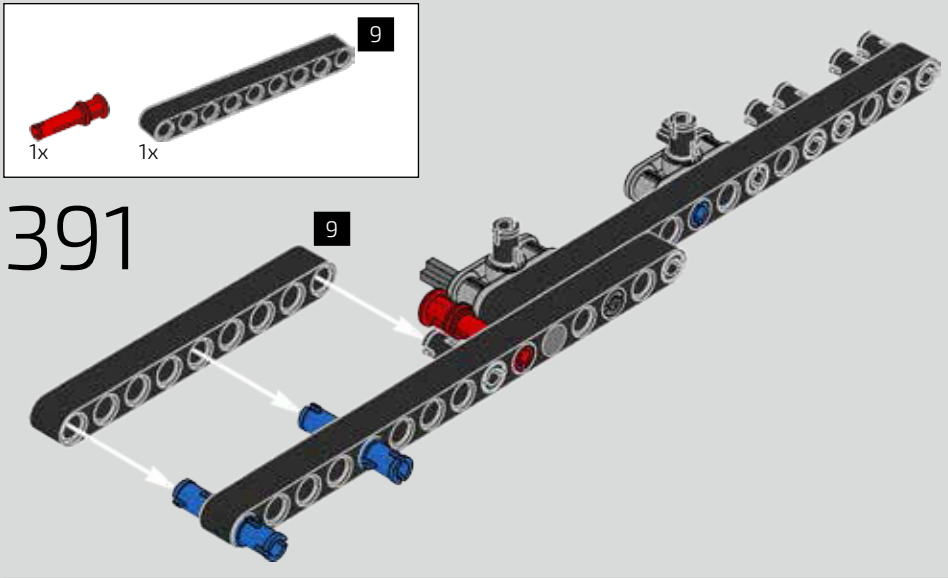

392

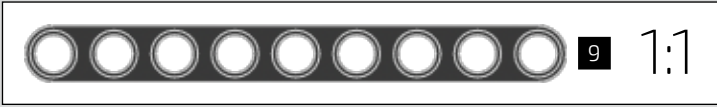
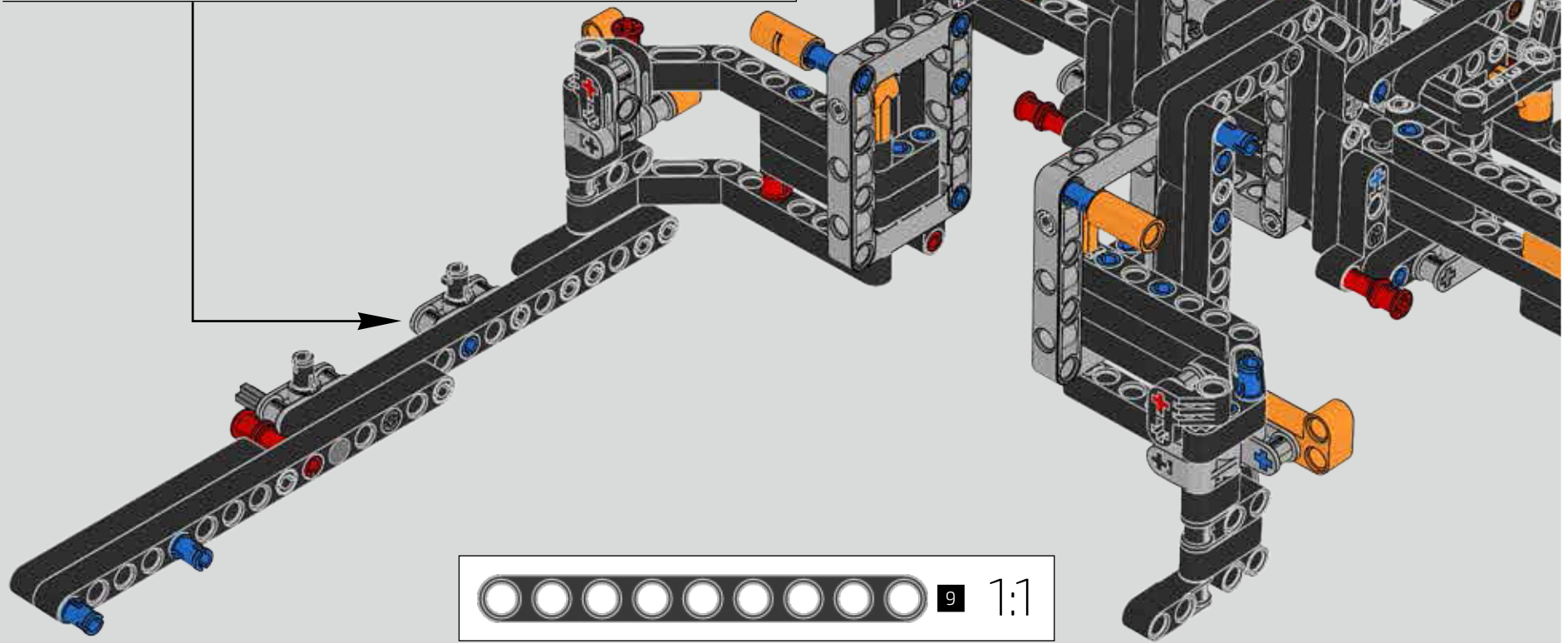

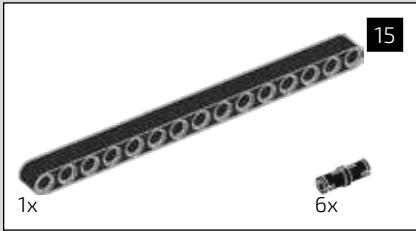
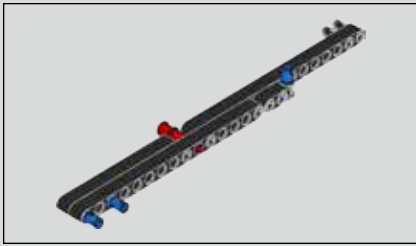

393

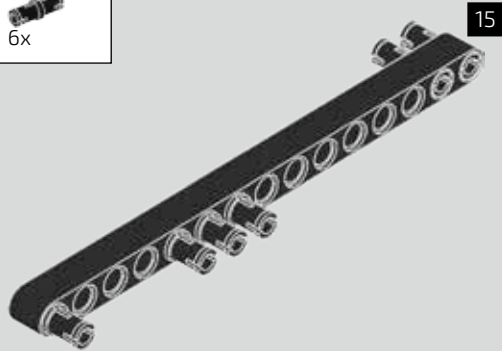

394

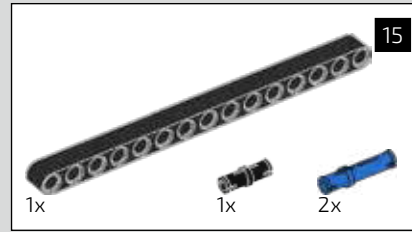
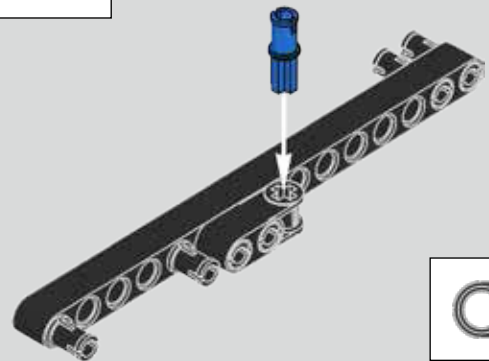

395

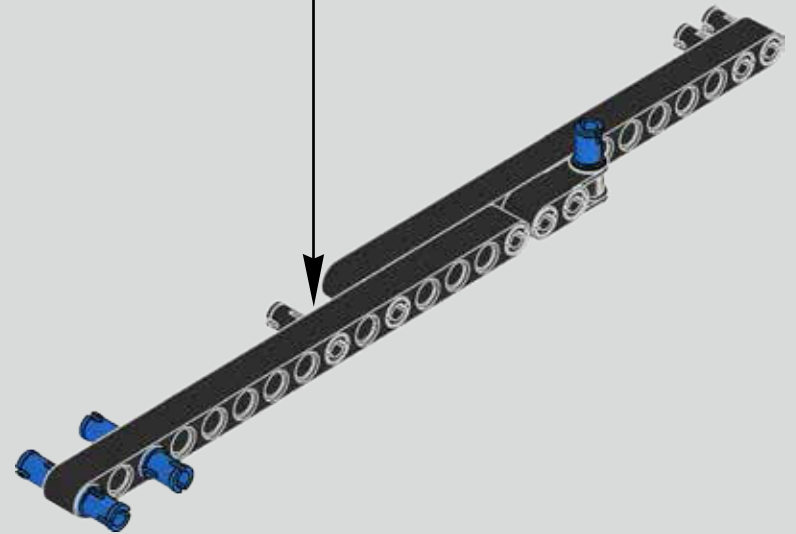
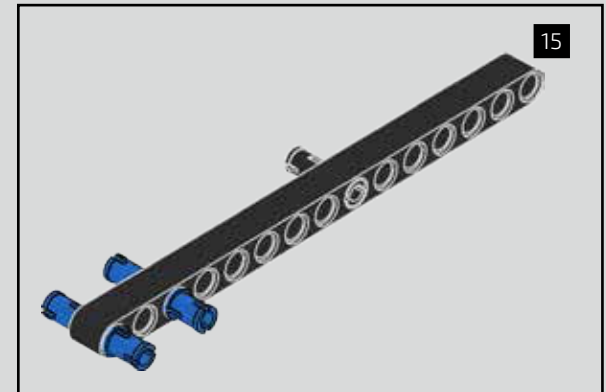

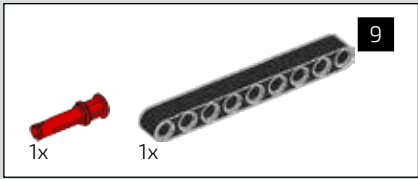

396

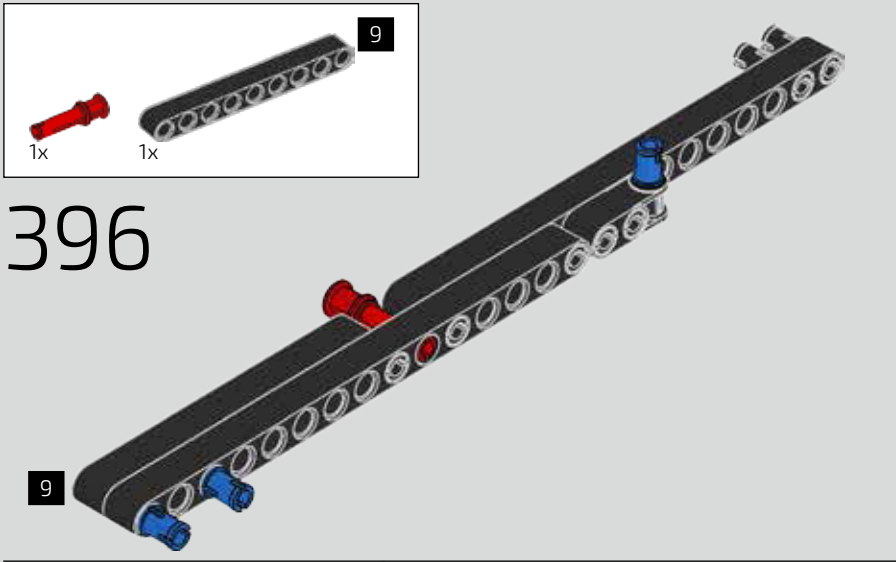

397

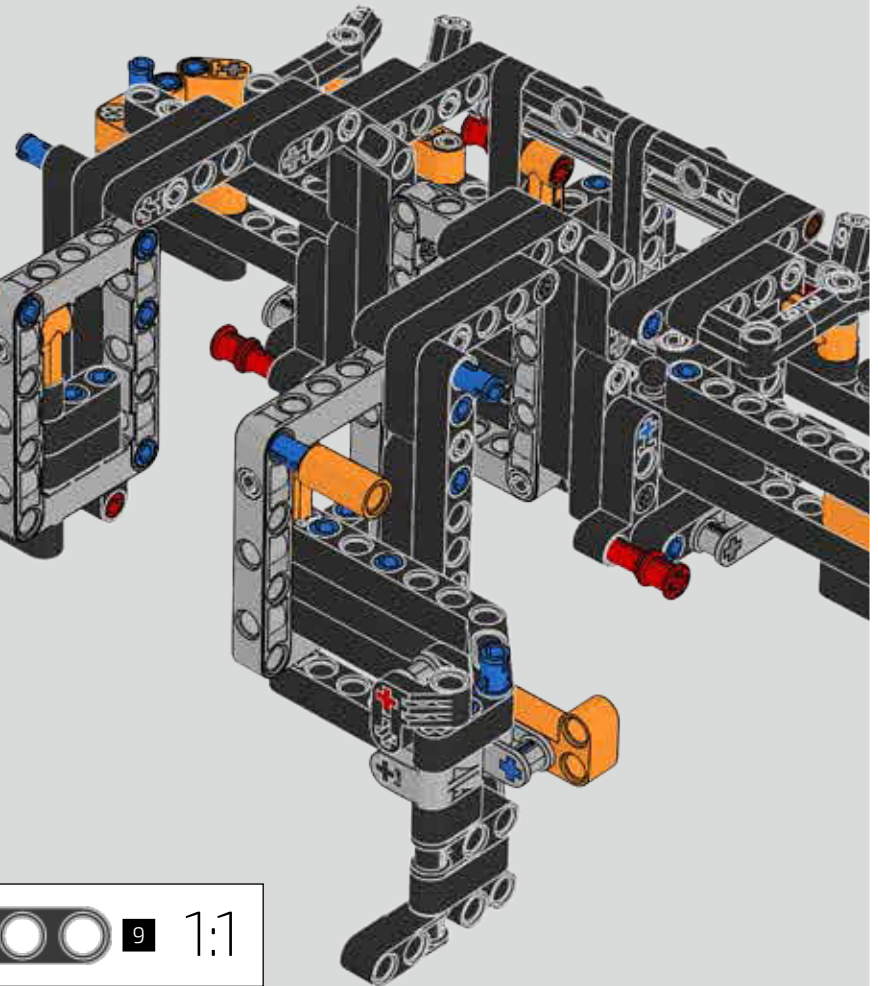



398

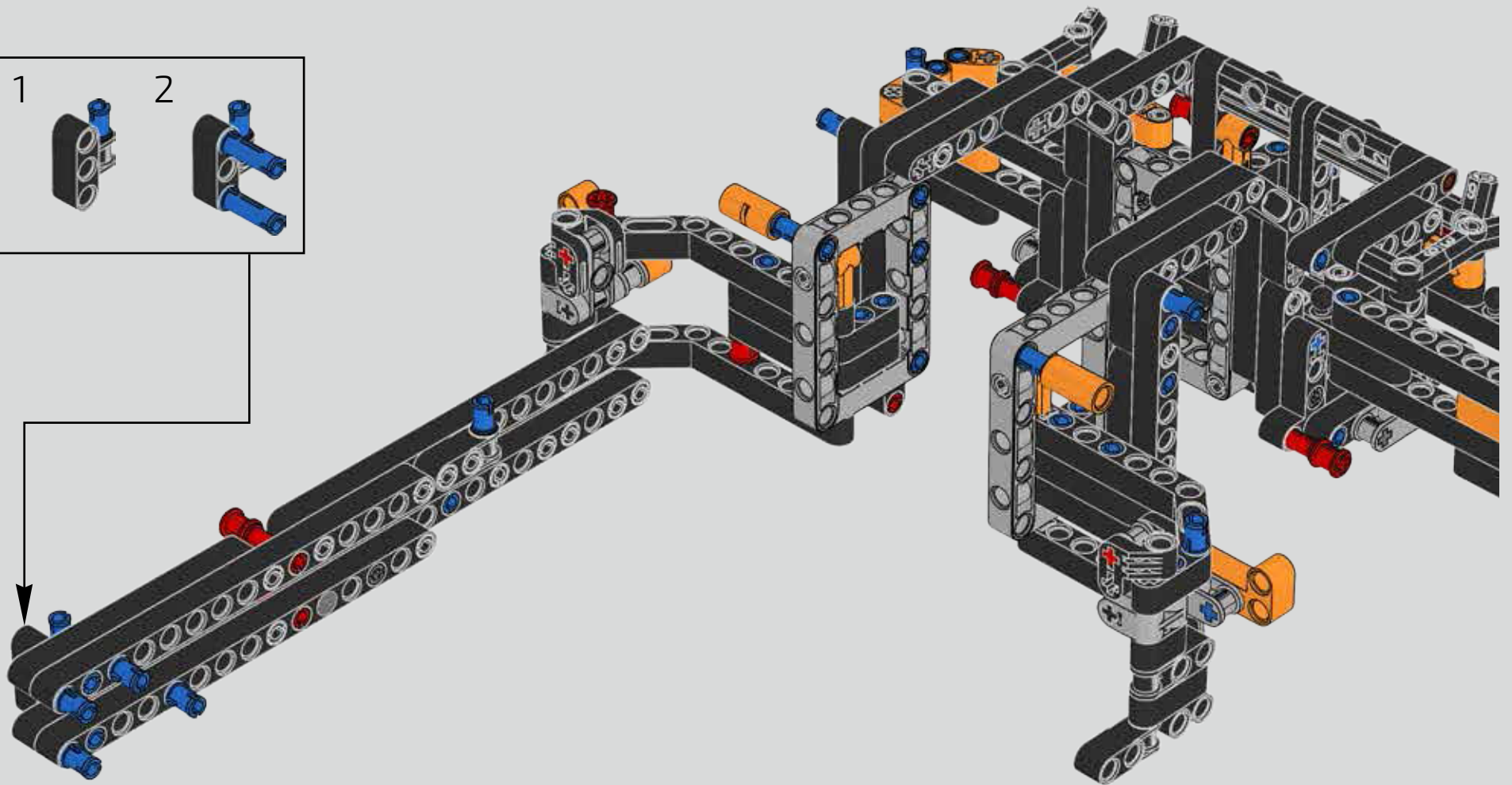
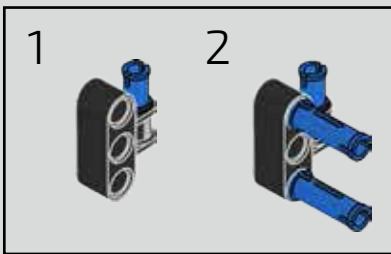

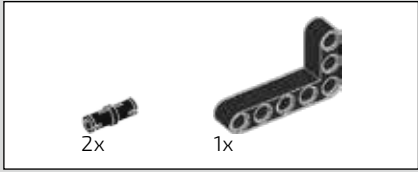

399

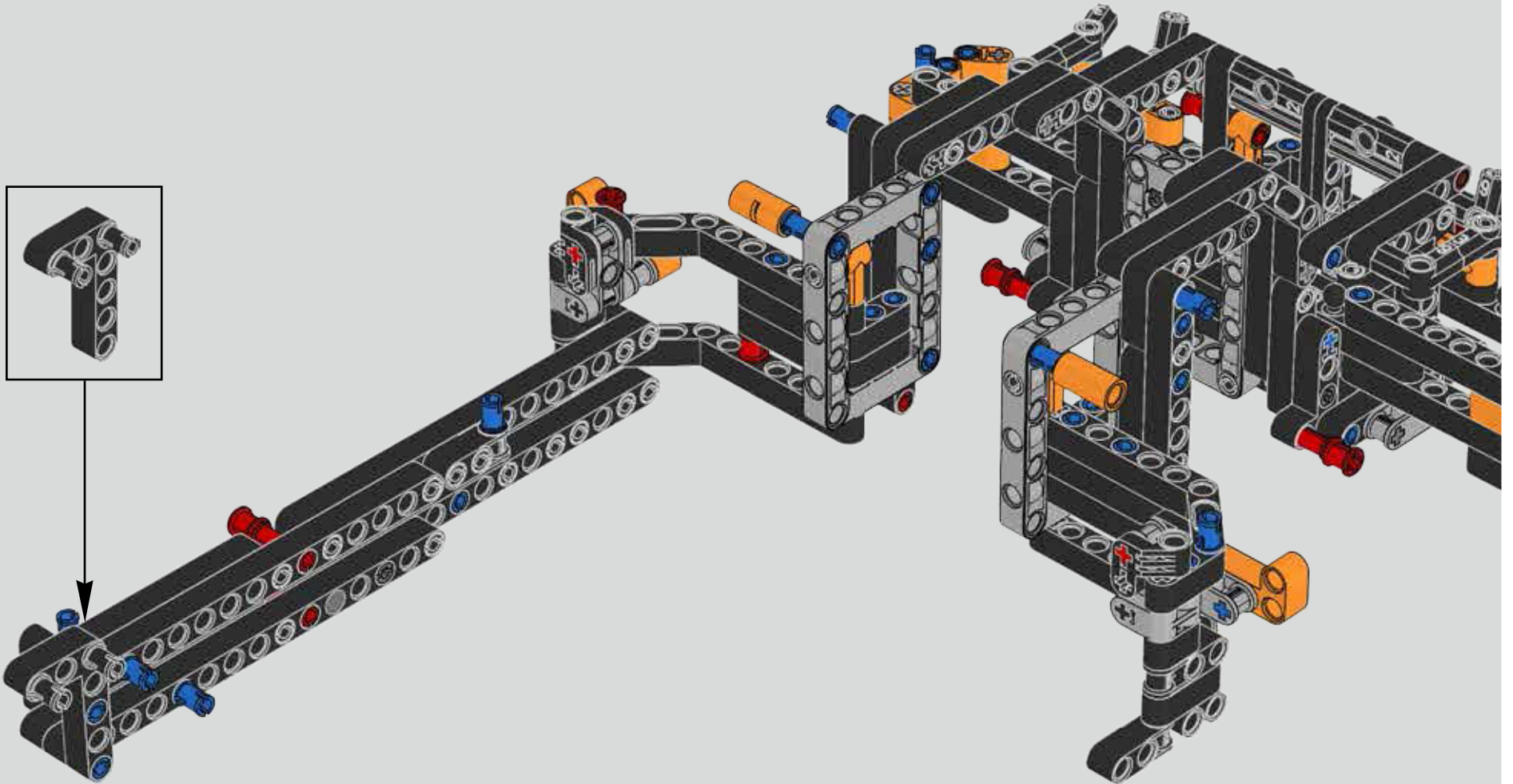

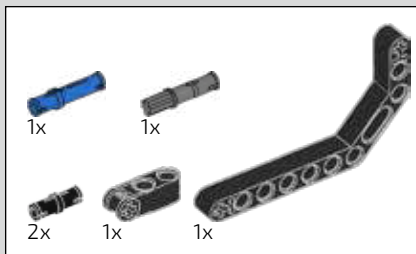

400

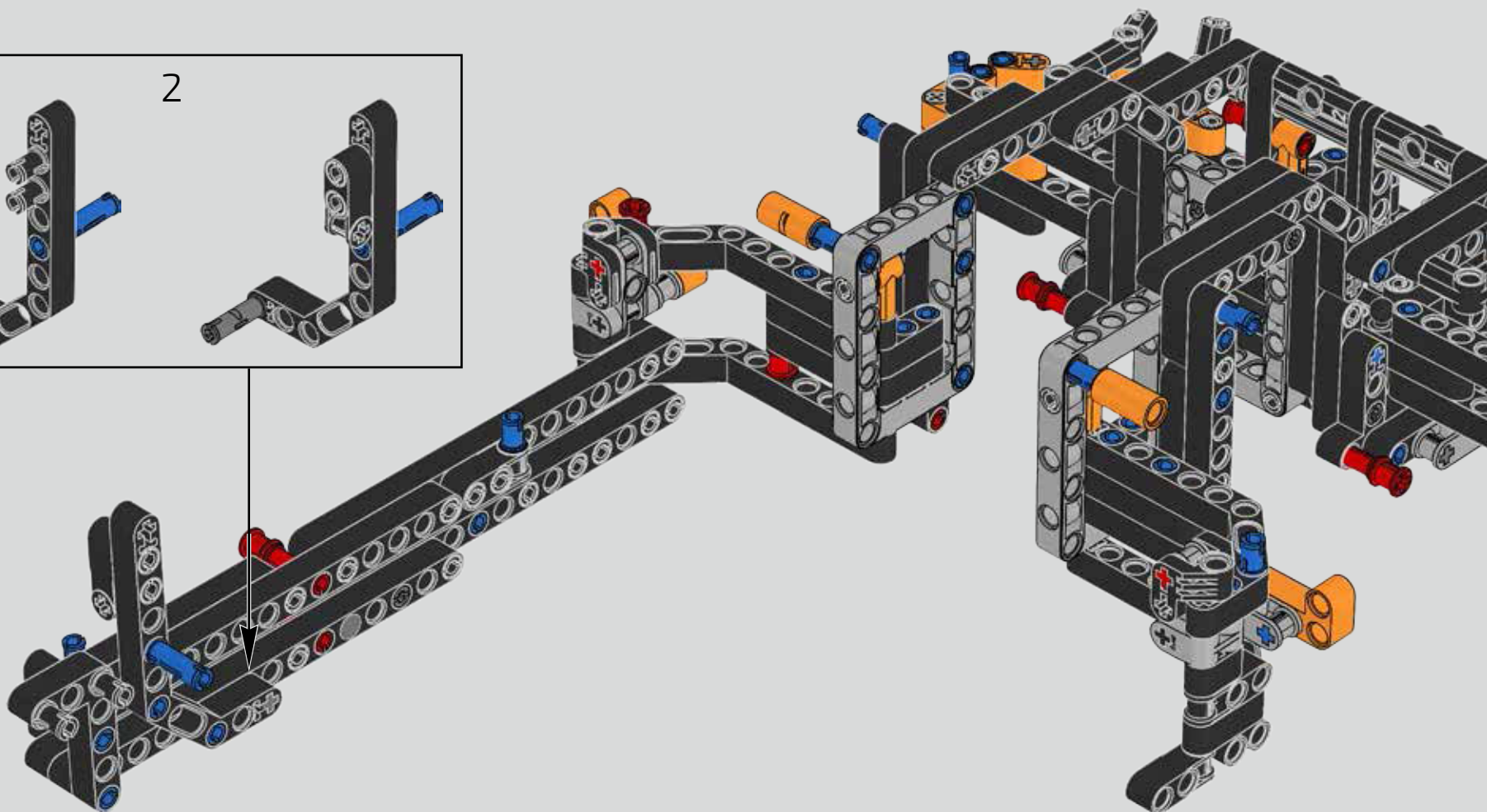
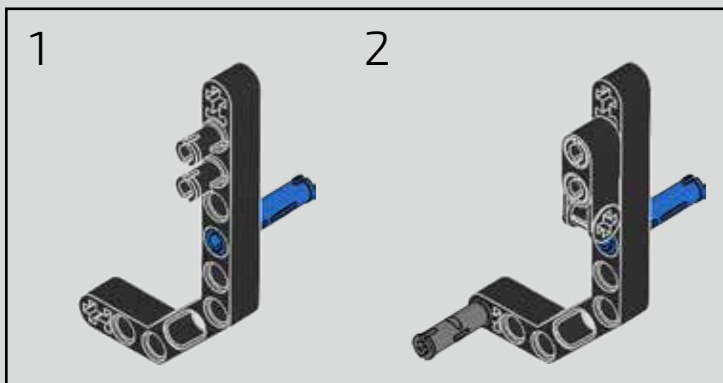



401



402

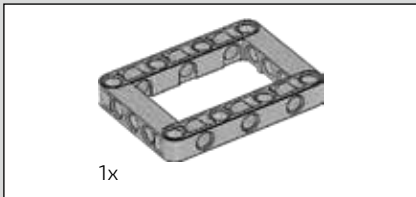
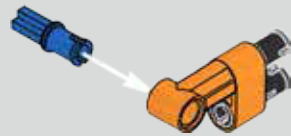

403

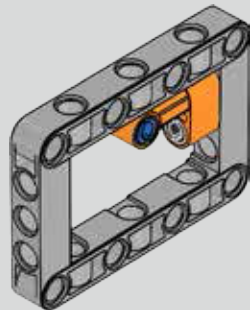

404

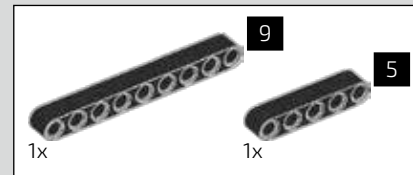
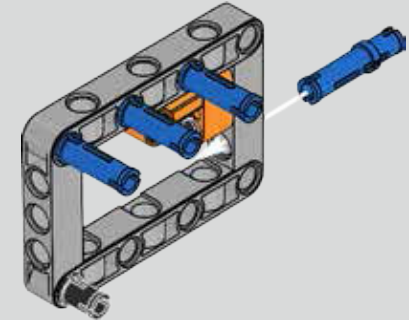

405

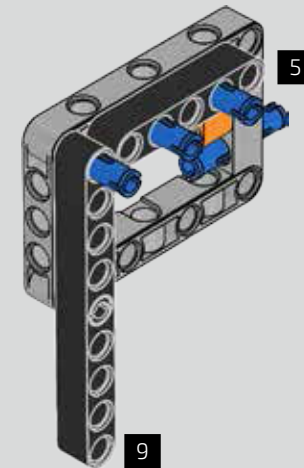

406

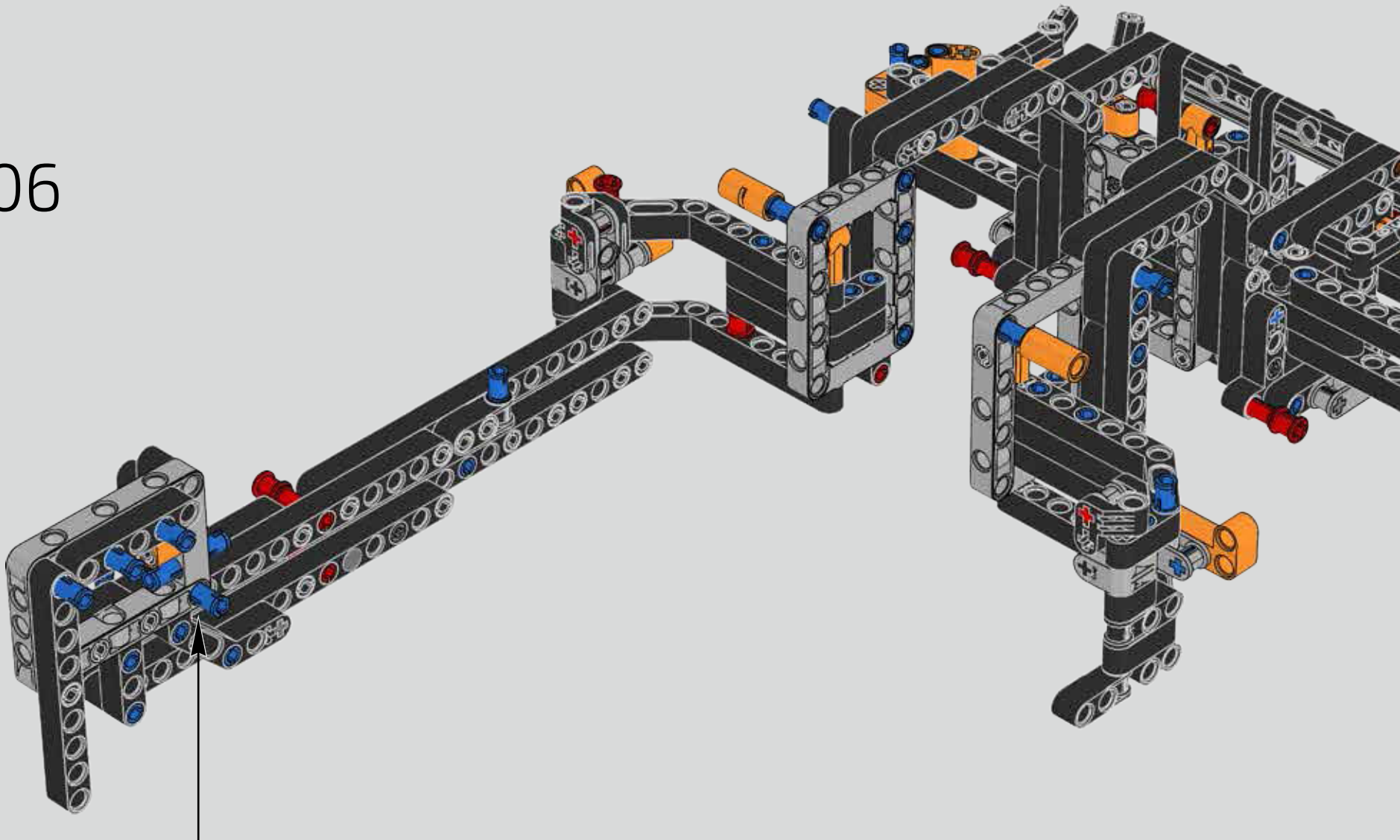

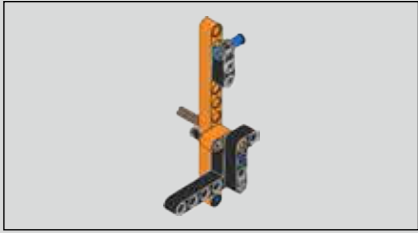

407

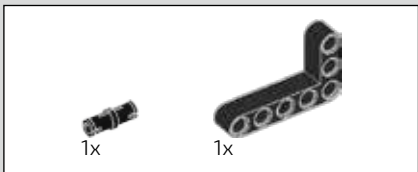
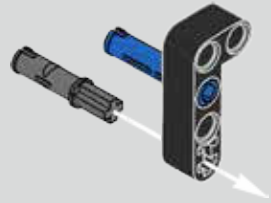

408

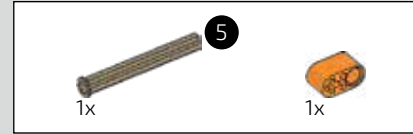
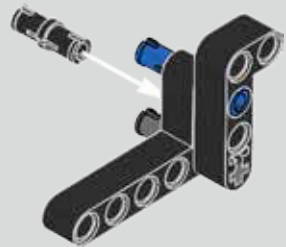

409

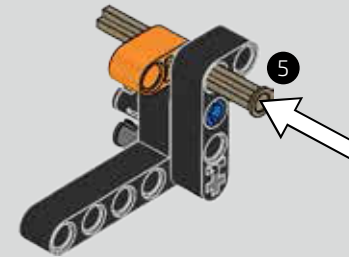

410

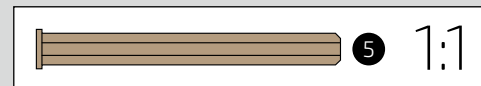
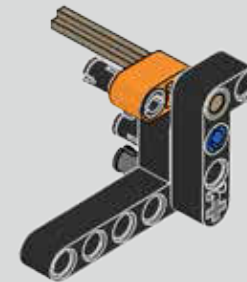

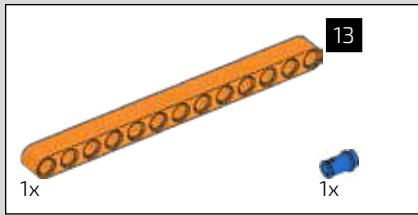

411

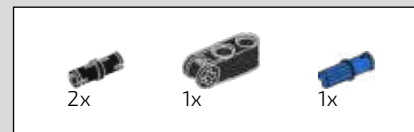
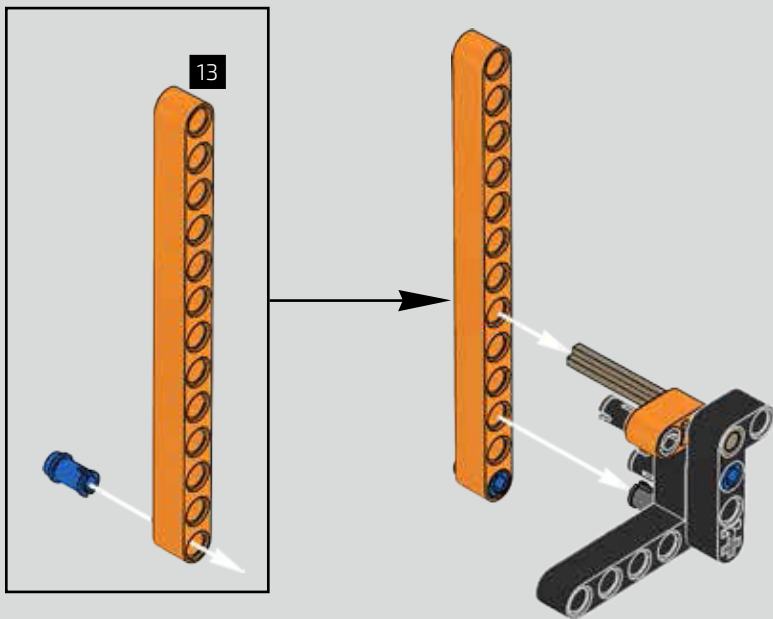

412

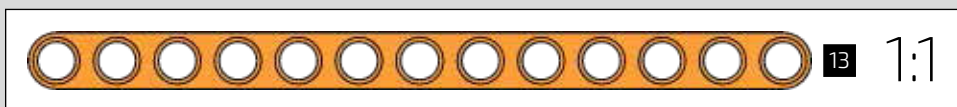
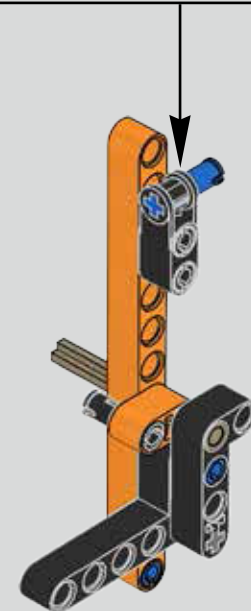
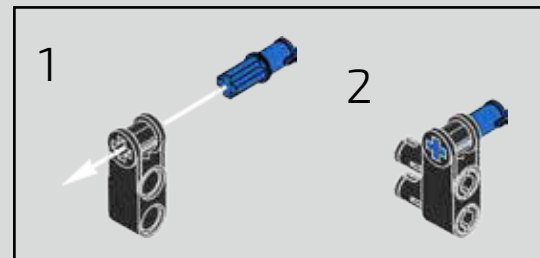

413

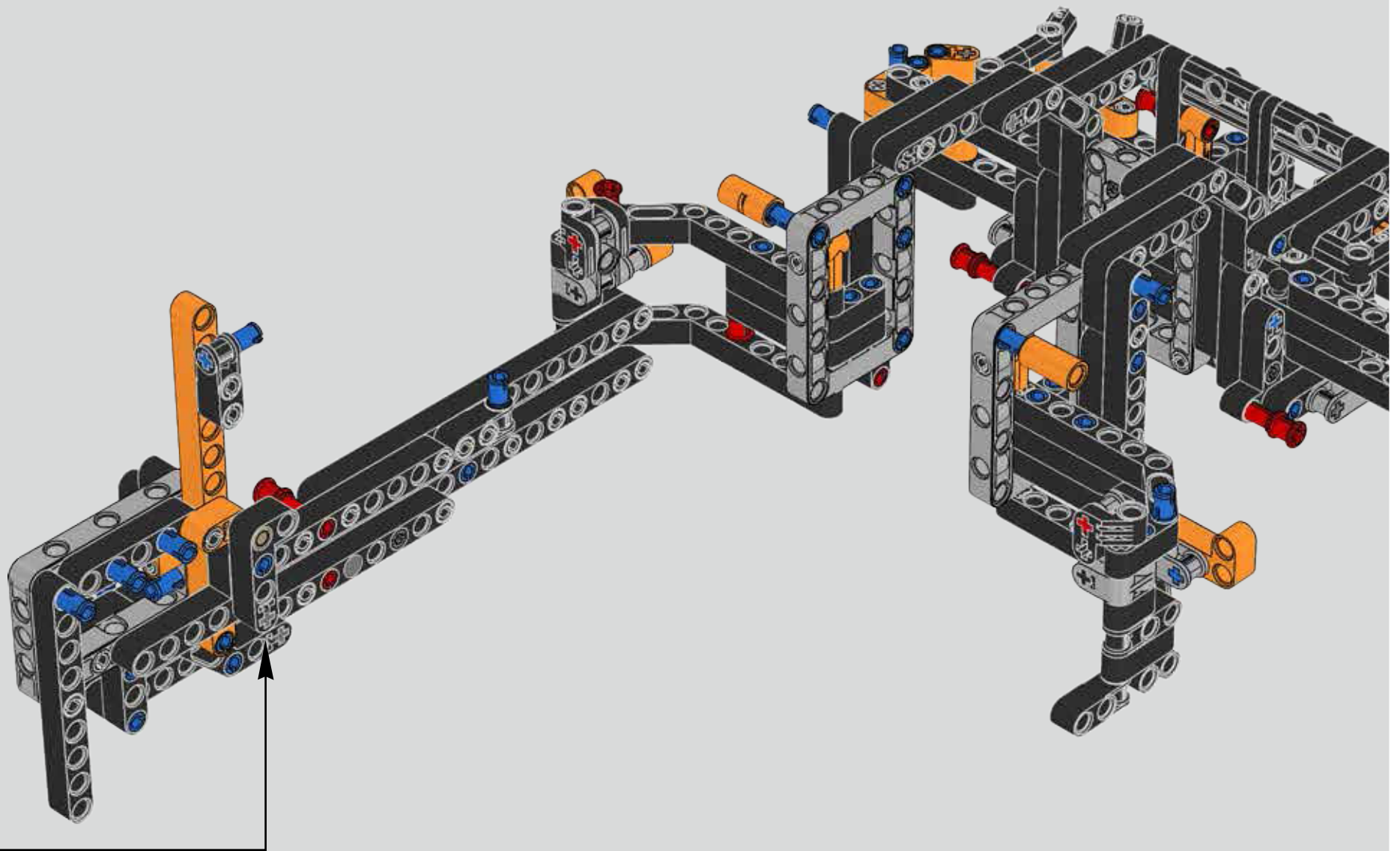

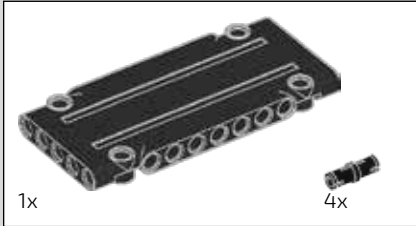
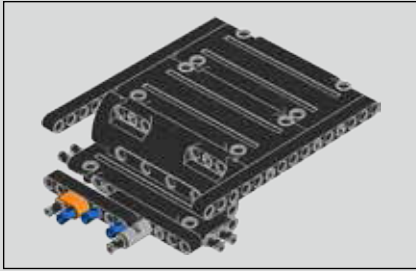

1x

4x

414

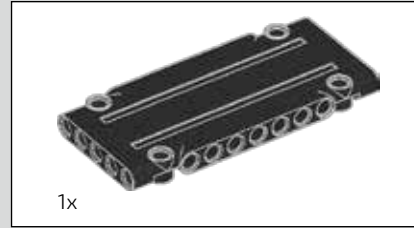
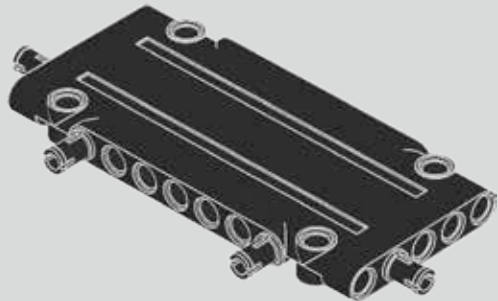

1x

415

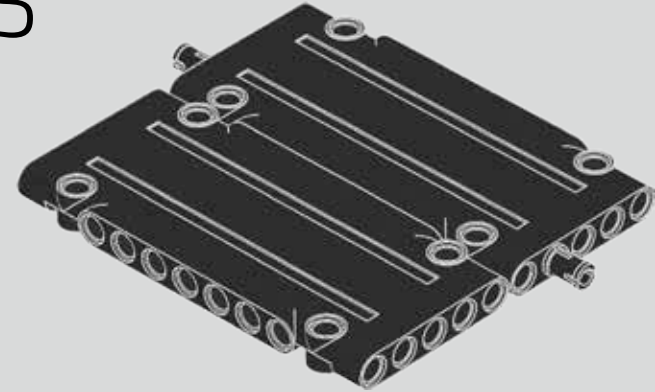

6x

416

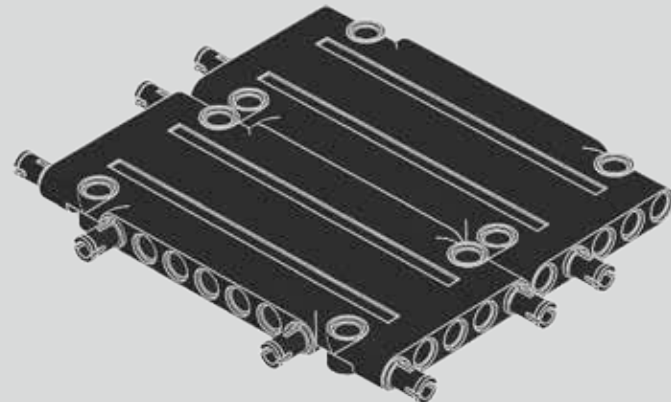

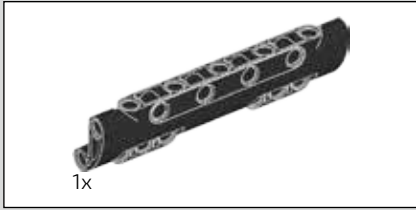

417

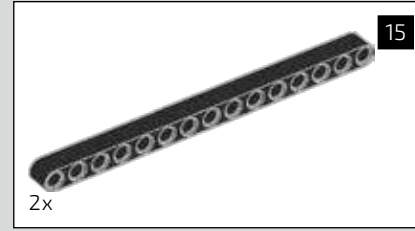
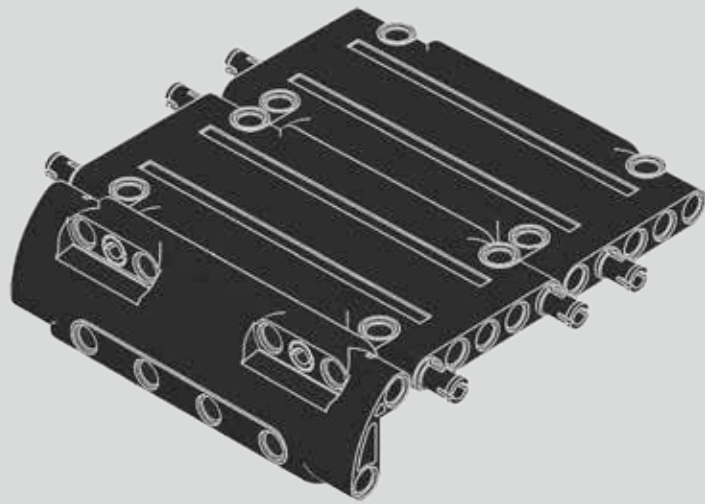

418

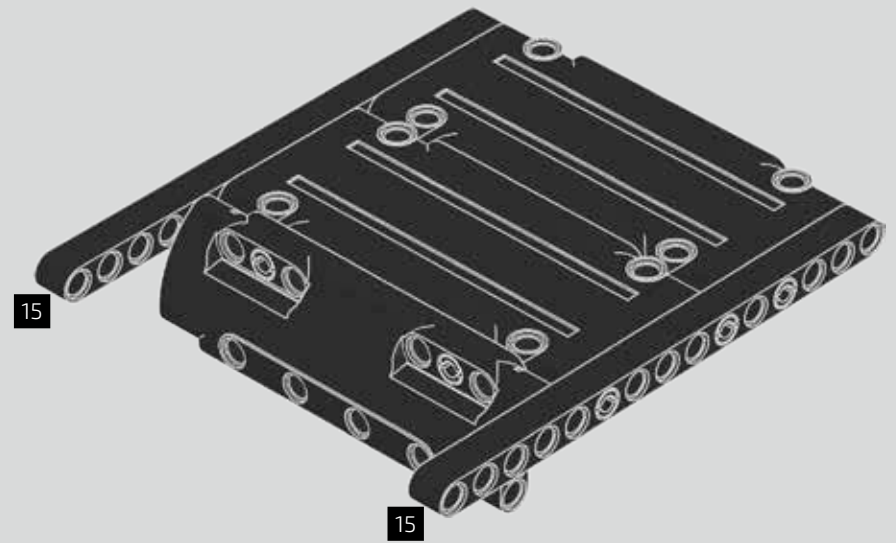

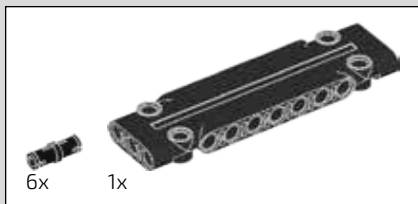

419

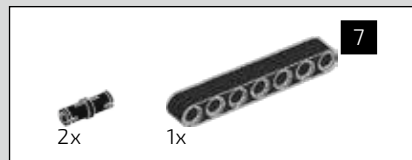
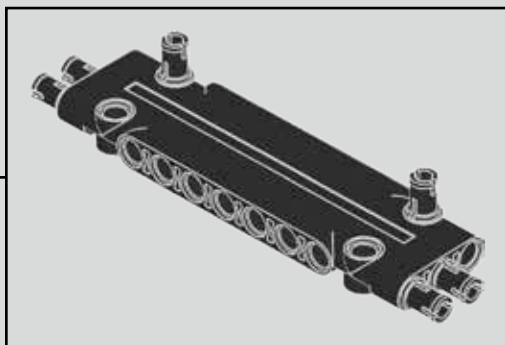
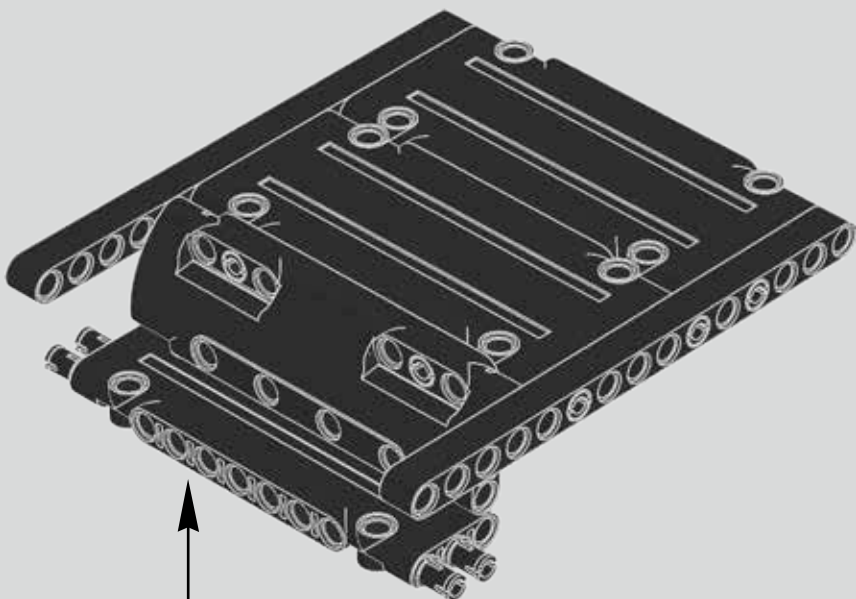

420

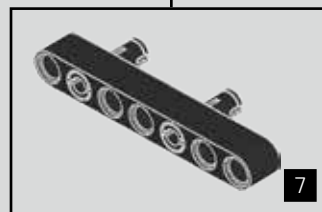
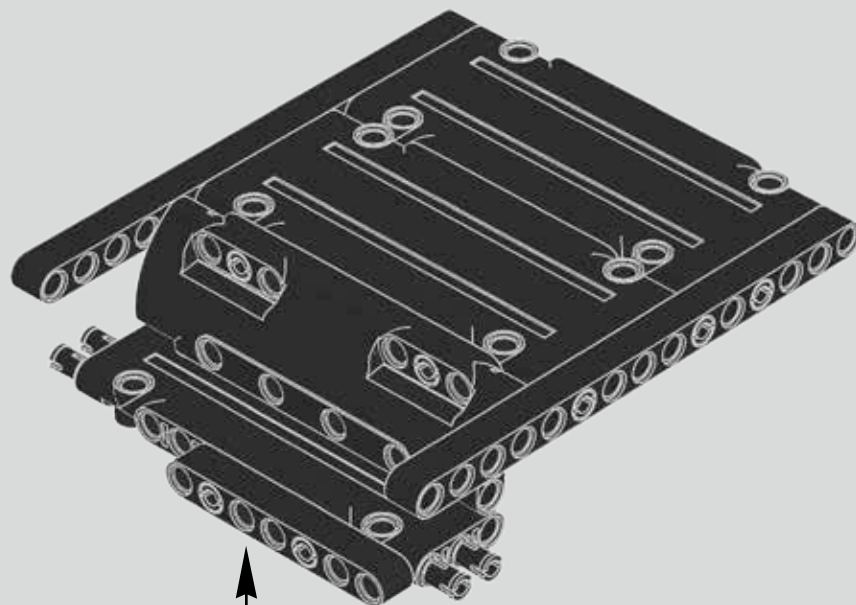

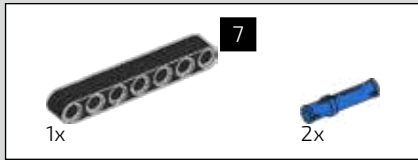

421

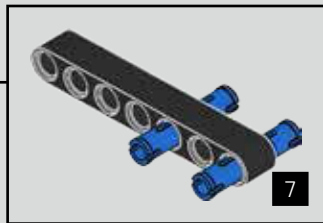
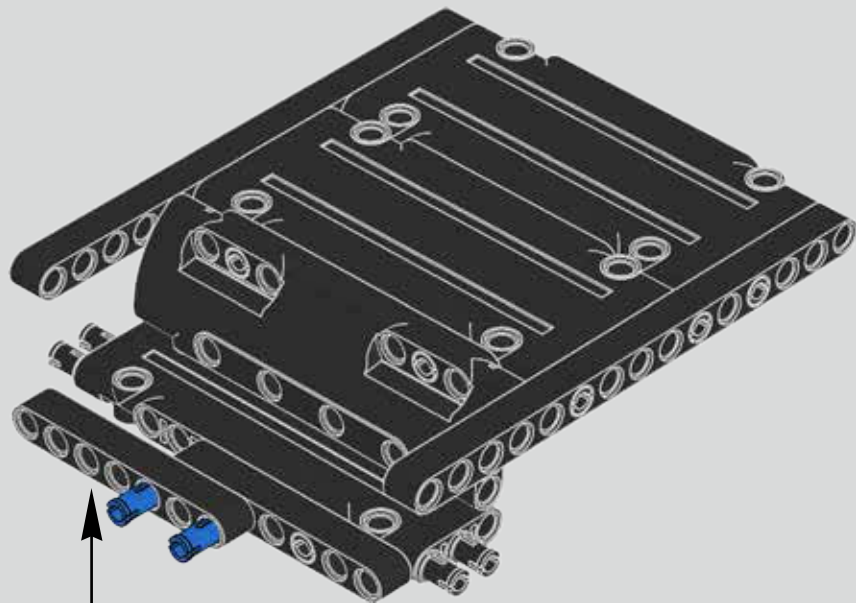

422

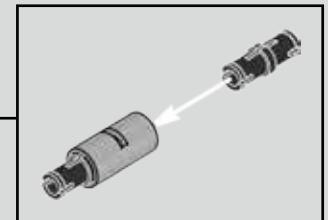
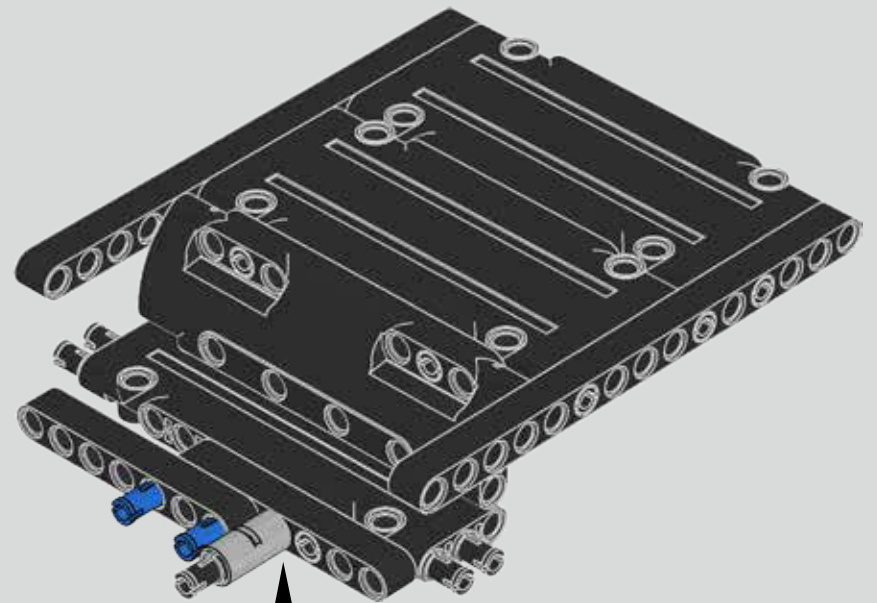



423

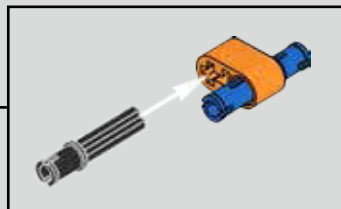
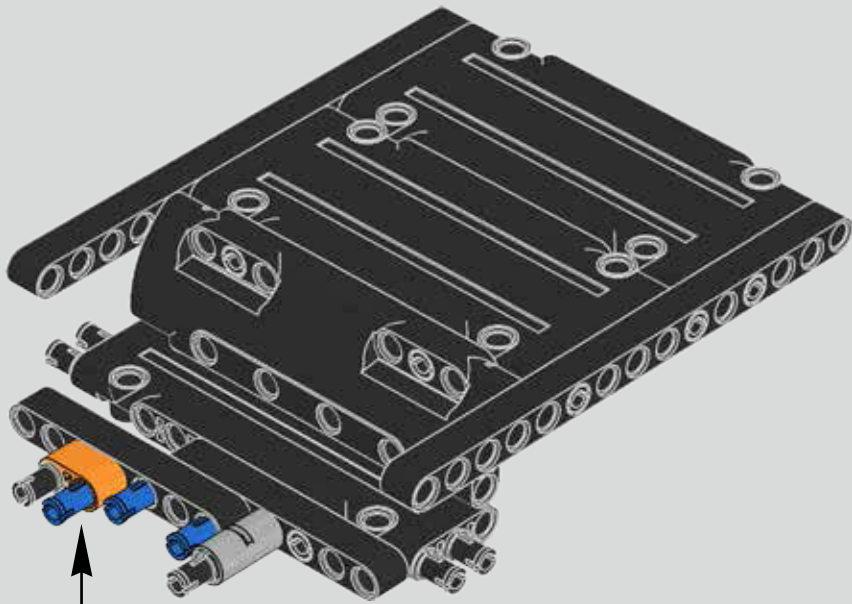

424

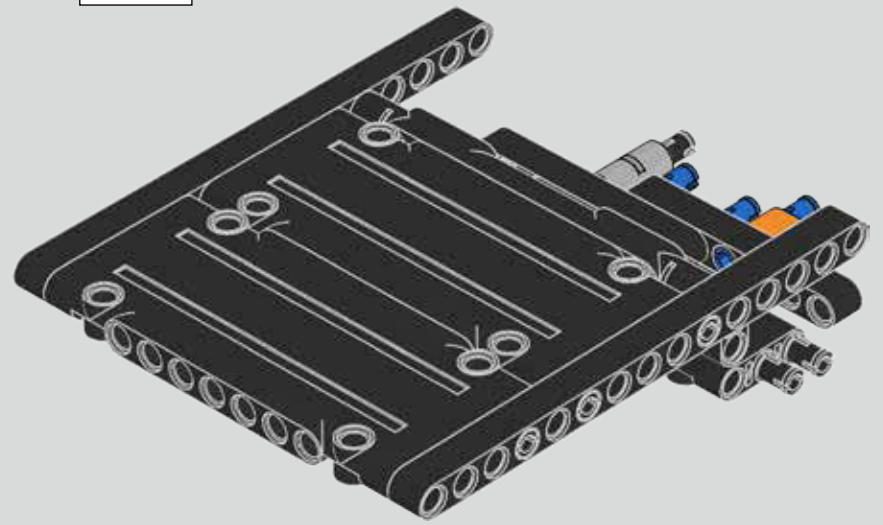
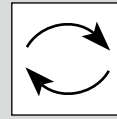

425

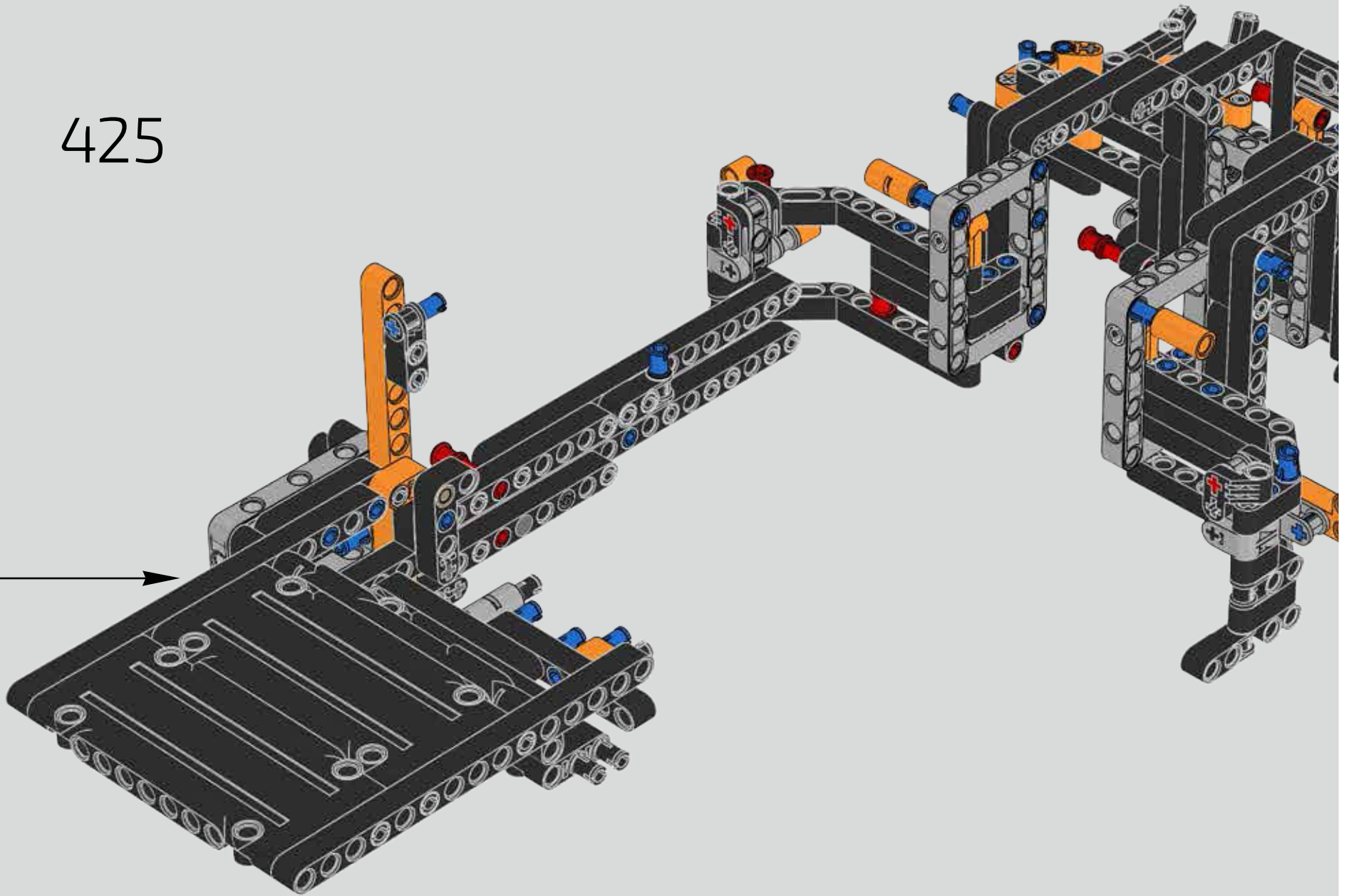

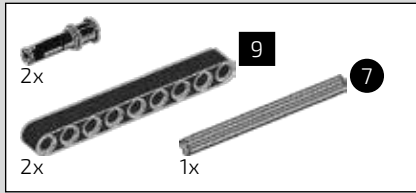

426

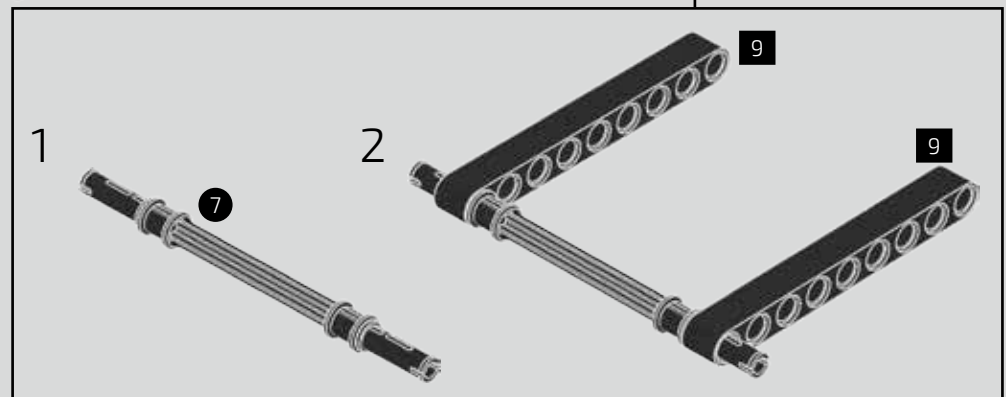
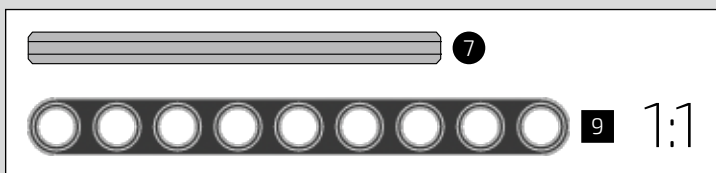
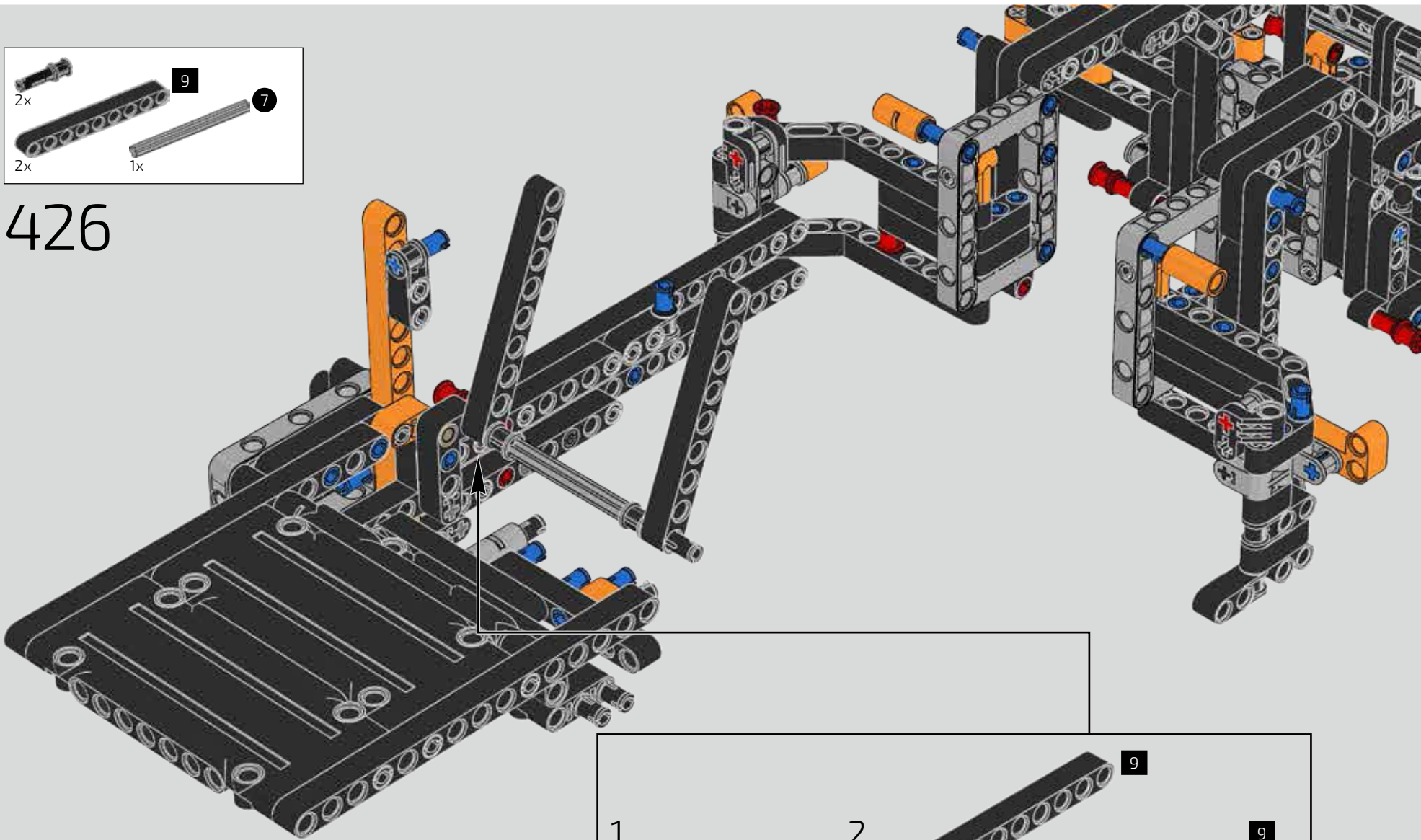

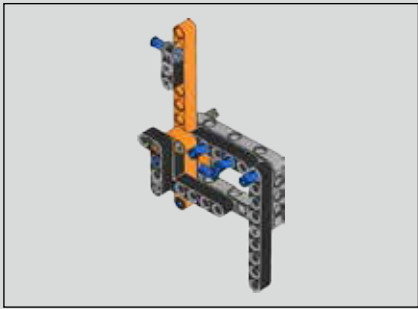

427

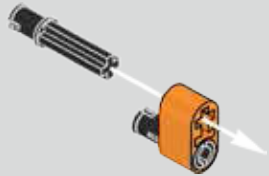

428

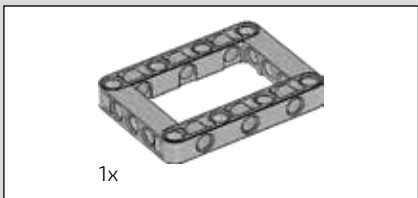
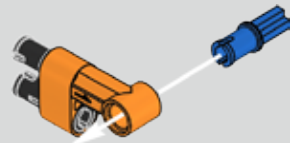

429

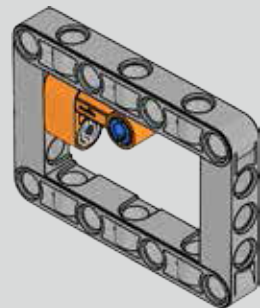

430

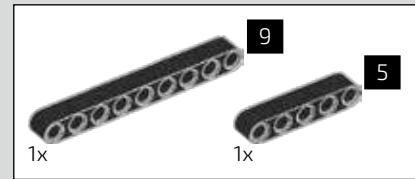
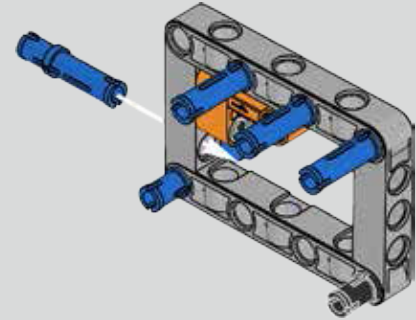

431

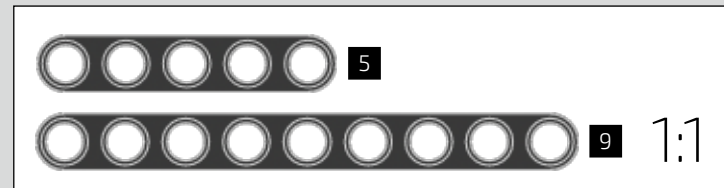
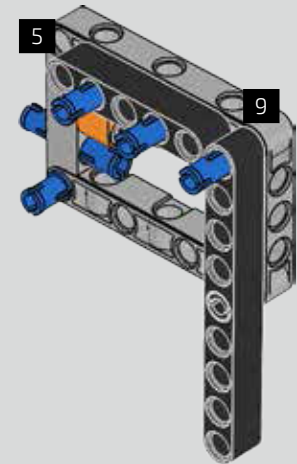

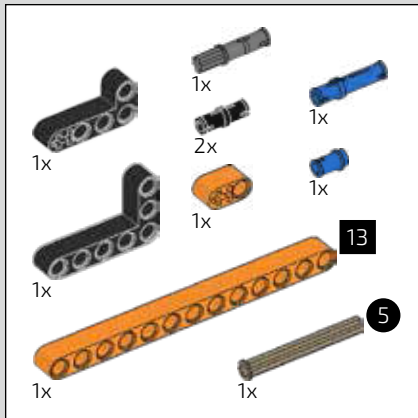

432

1



2

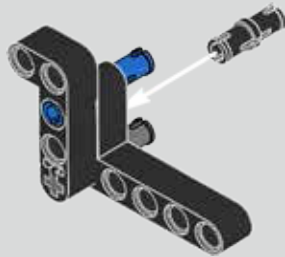

3

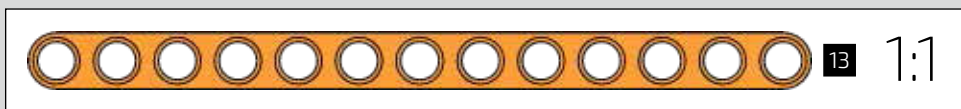
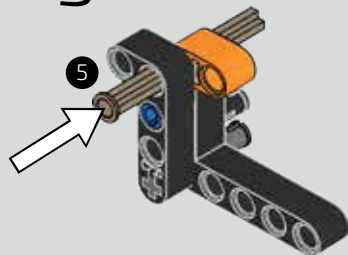

4

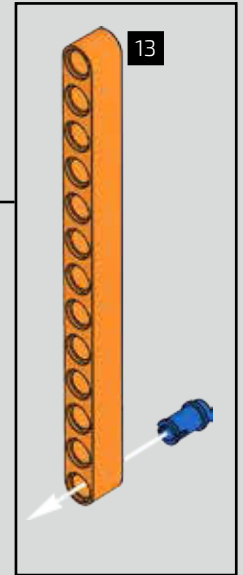
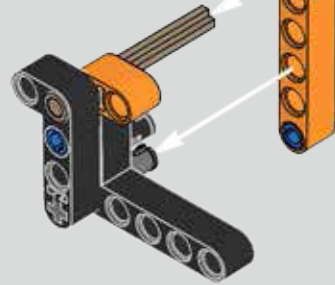

5

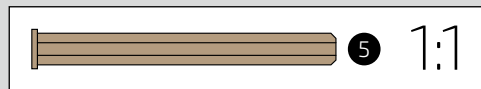
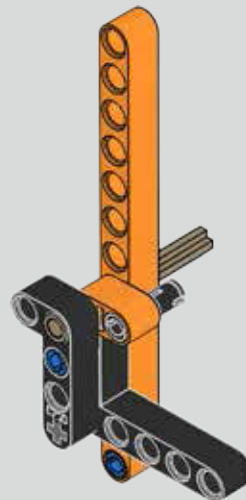

433

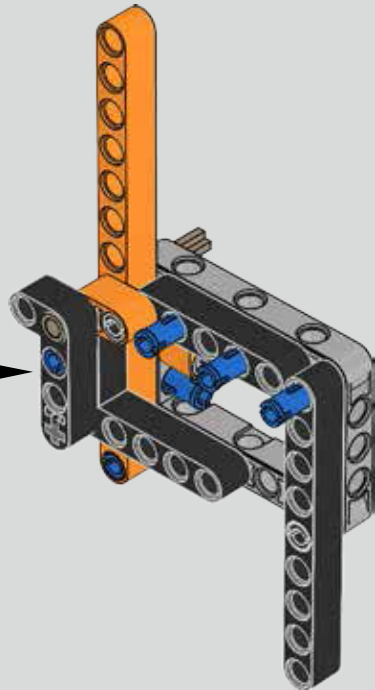

434

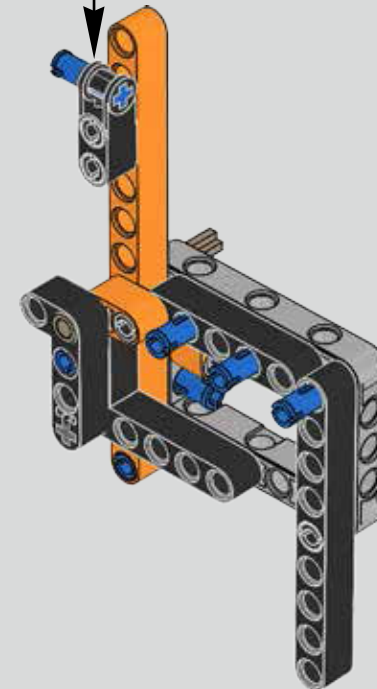
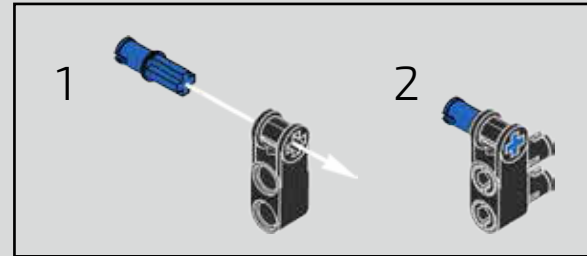

435

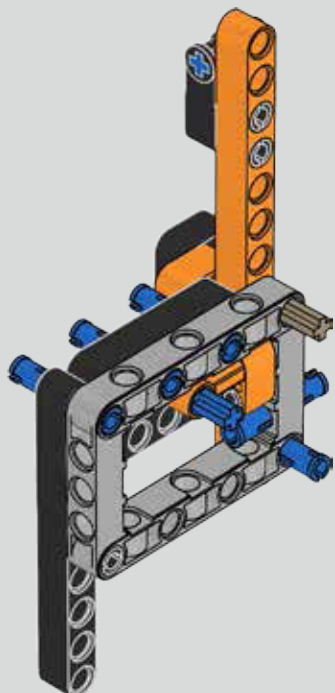
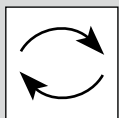

436

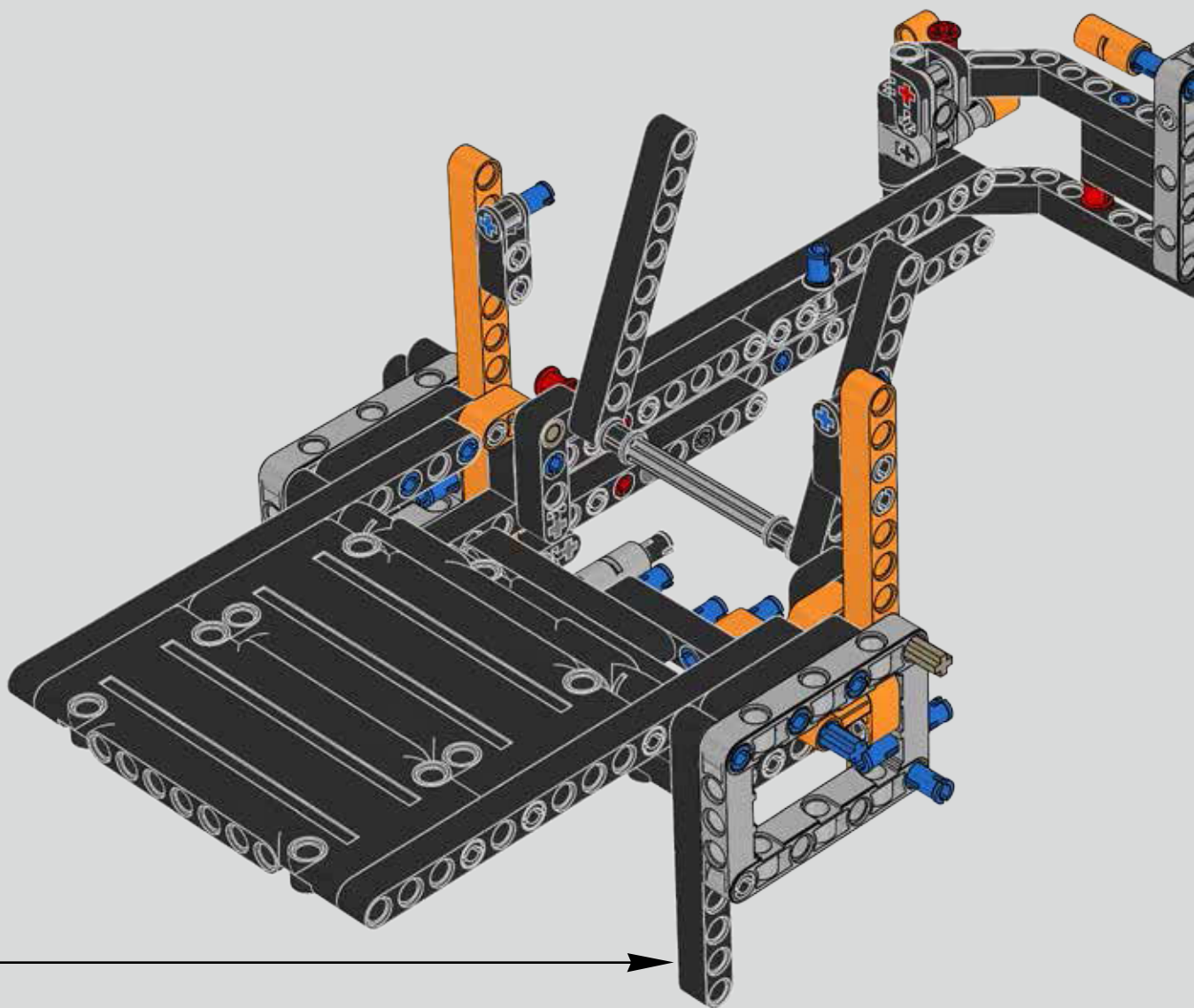

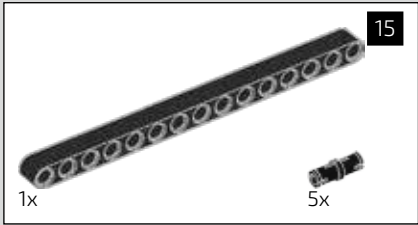
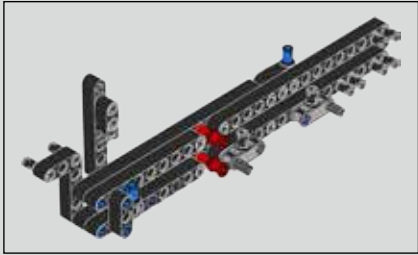

437

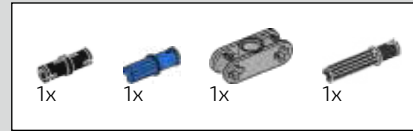
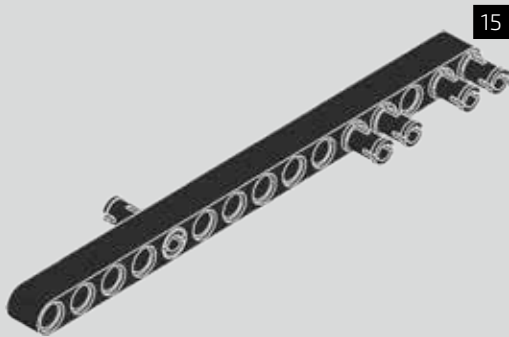

438

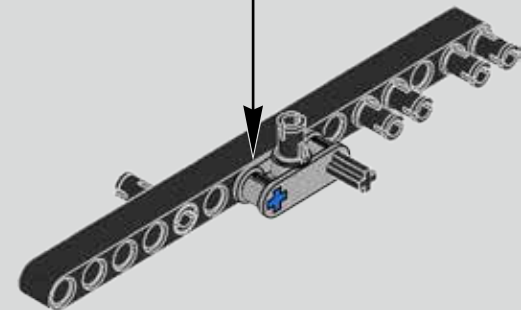
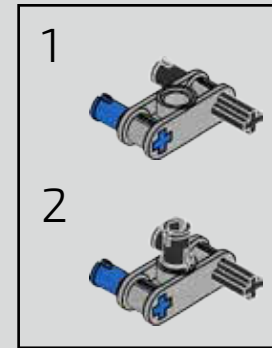

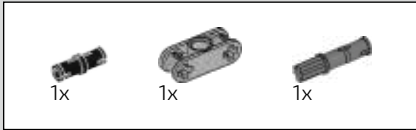

439

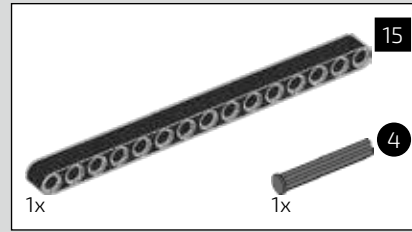
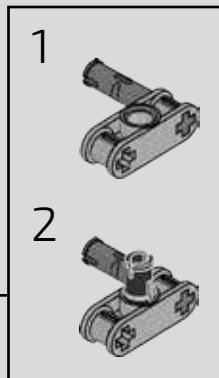
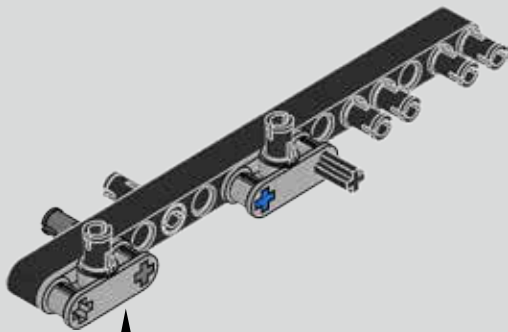

440

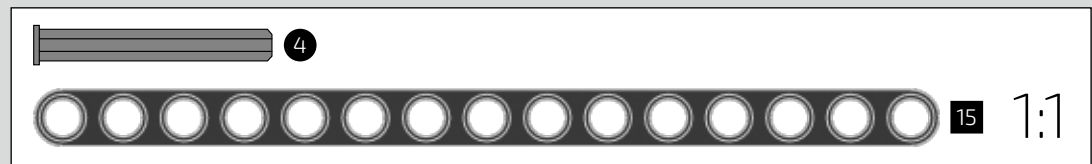
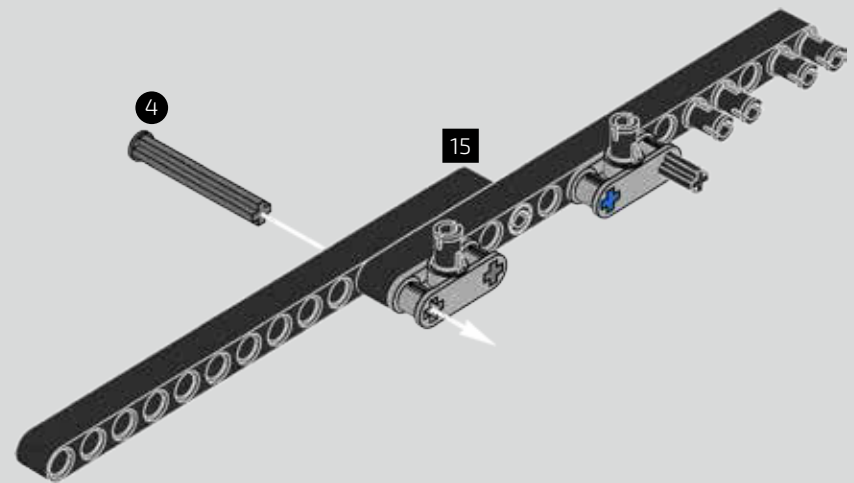

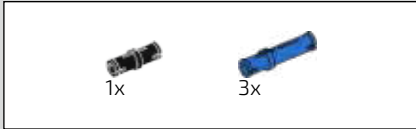

441

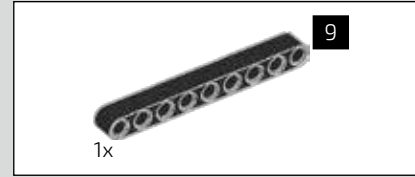
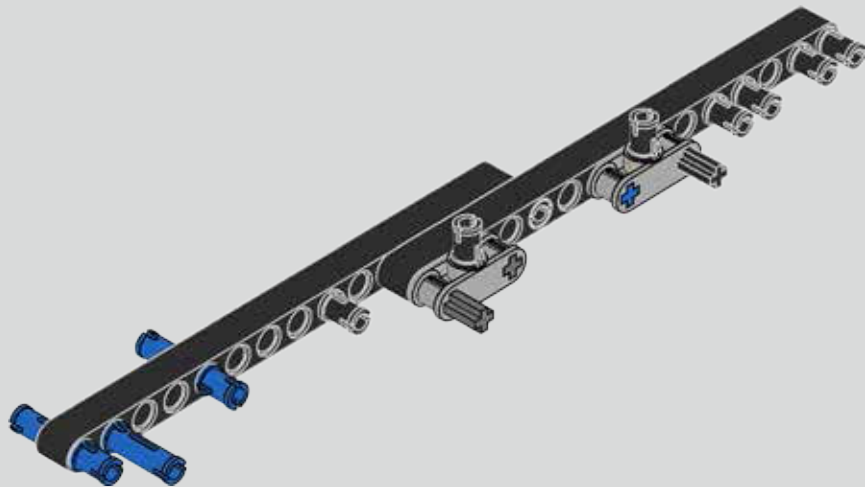

442

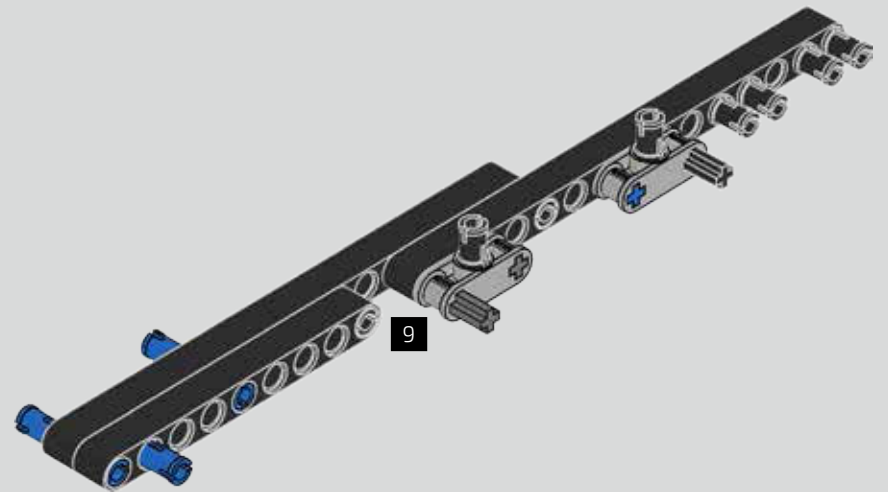

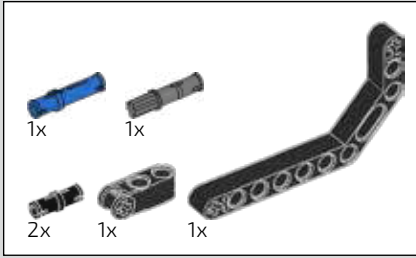

443

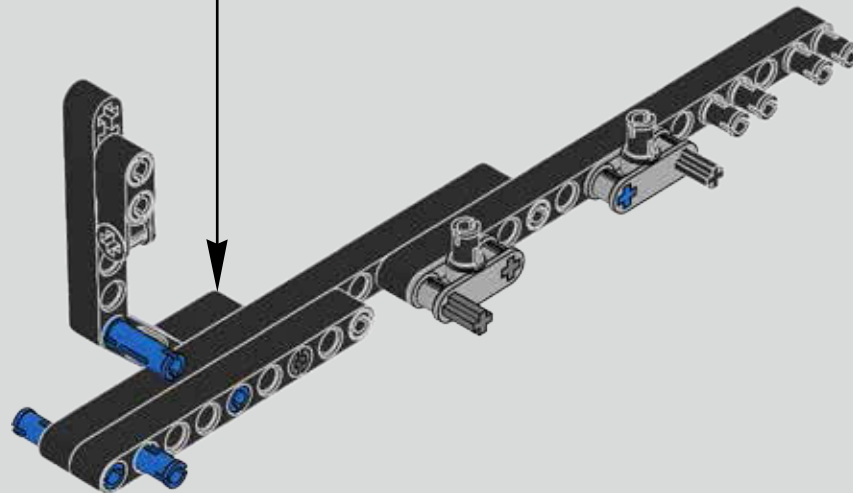
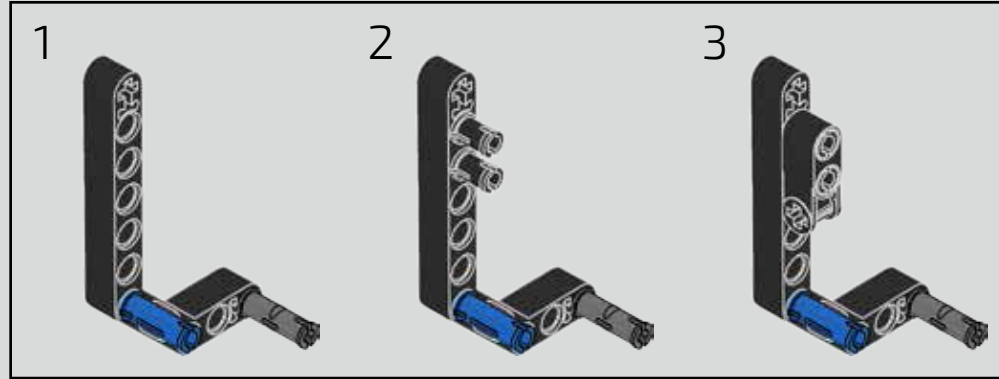

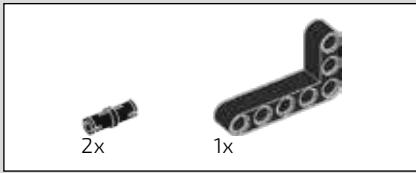

444

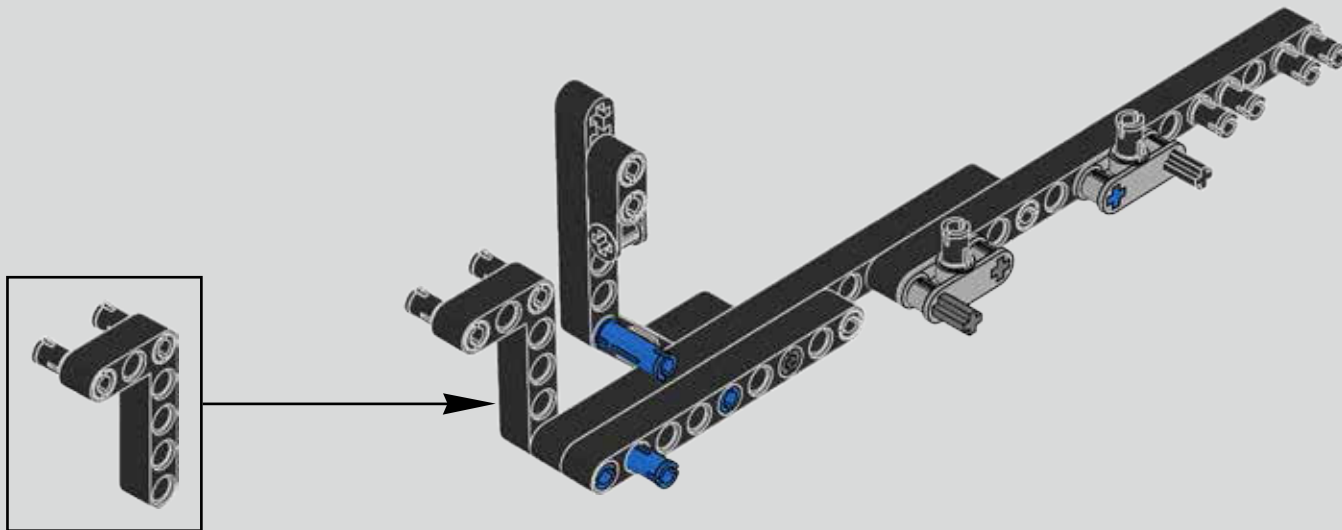

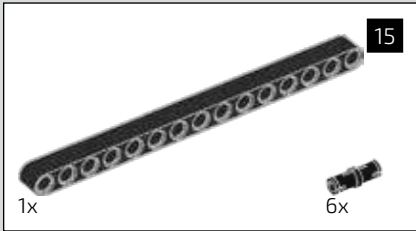
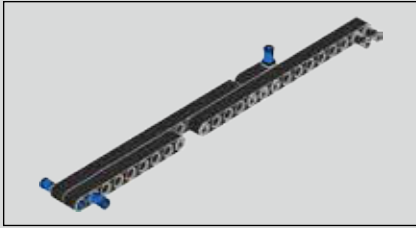

445

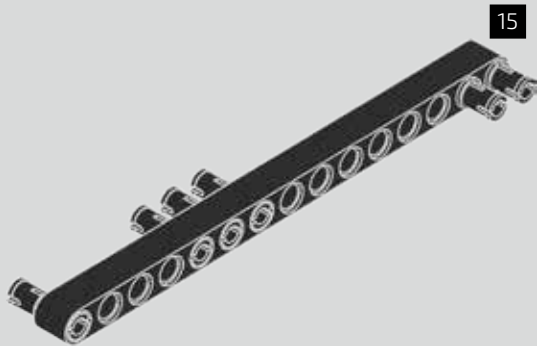

446

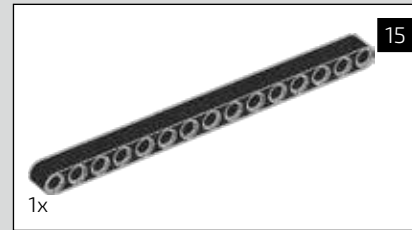
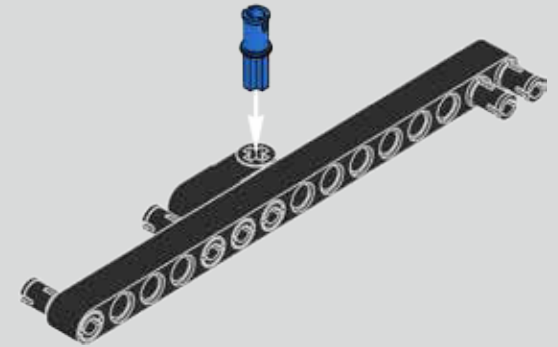

447

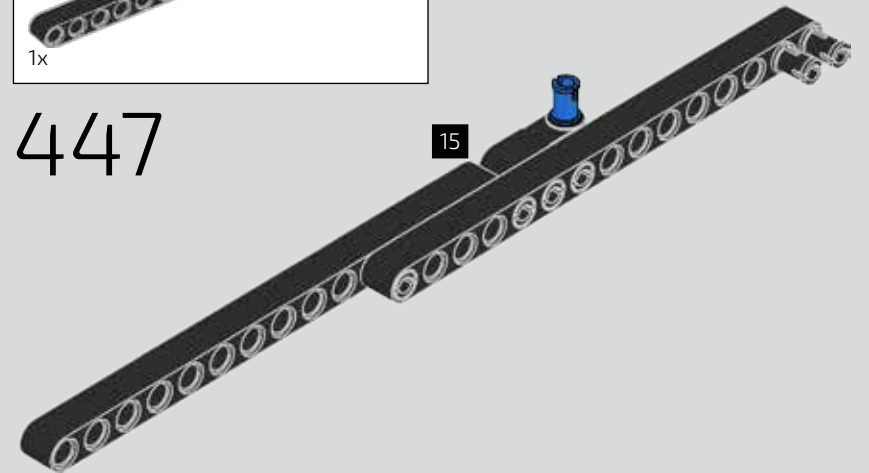

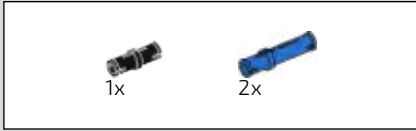

448

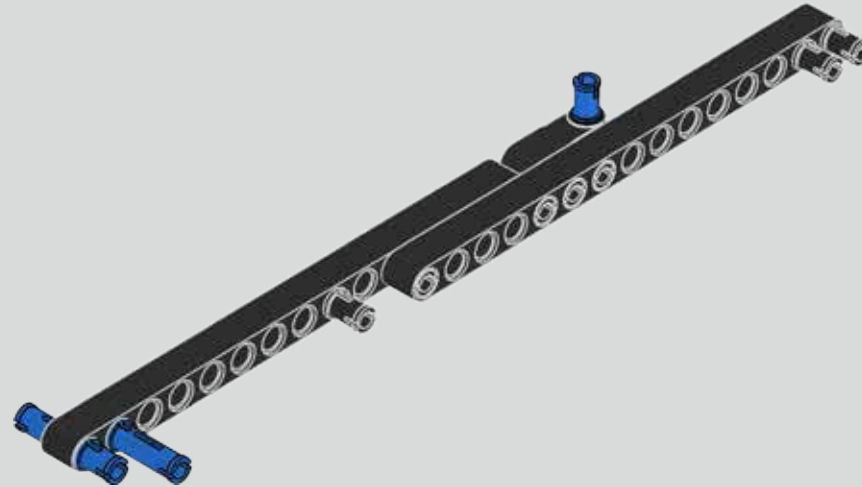

449

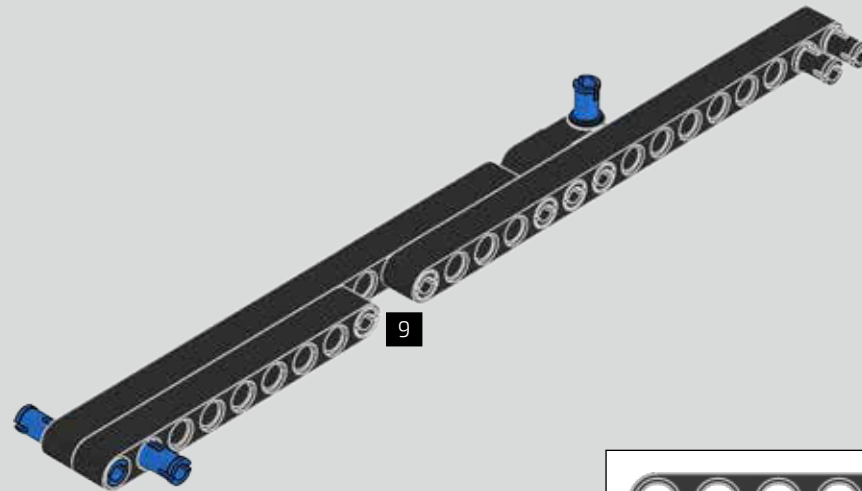

450

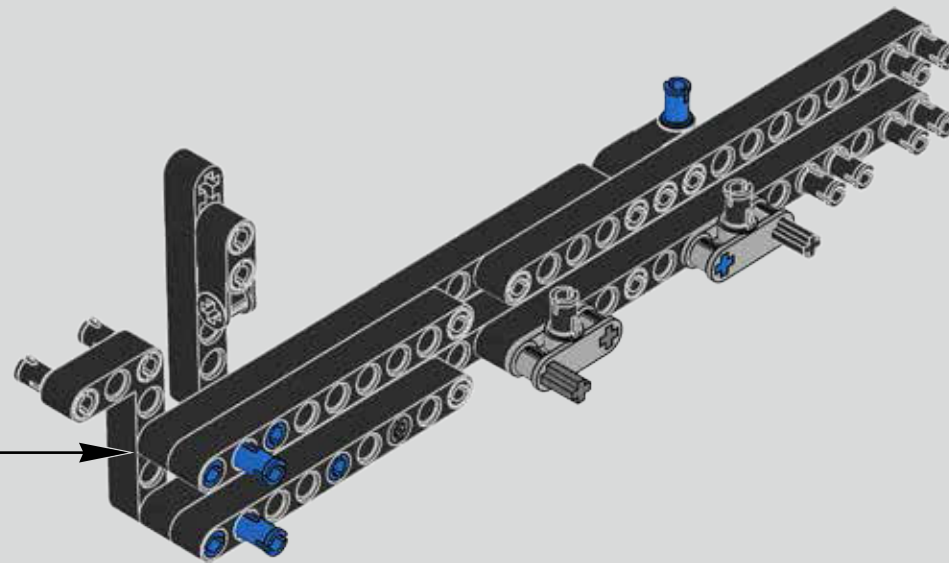

451

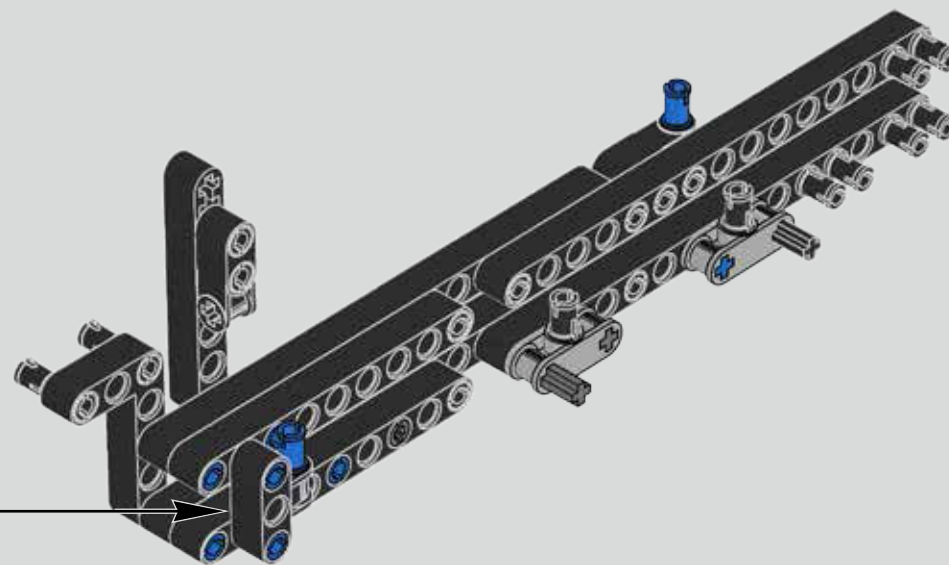
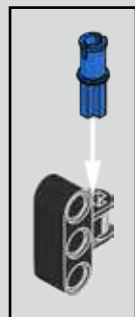

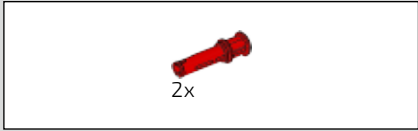

452

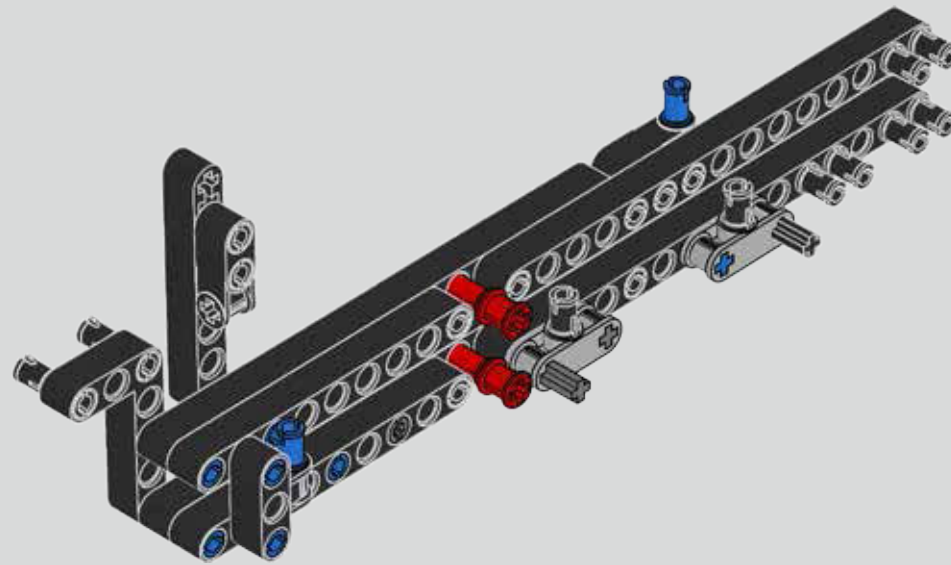

453

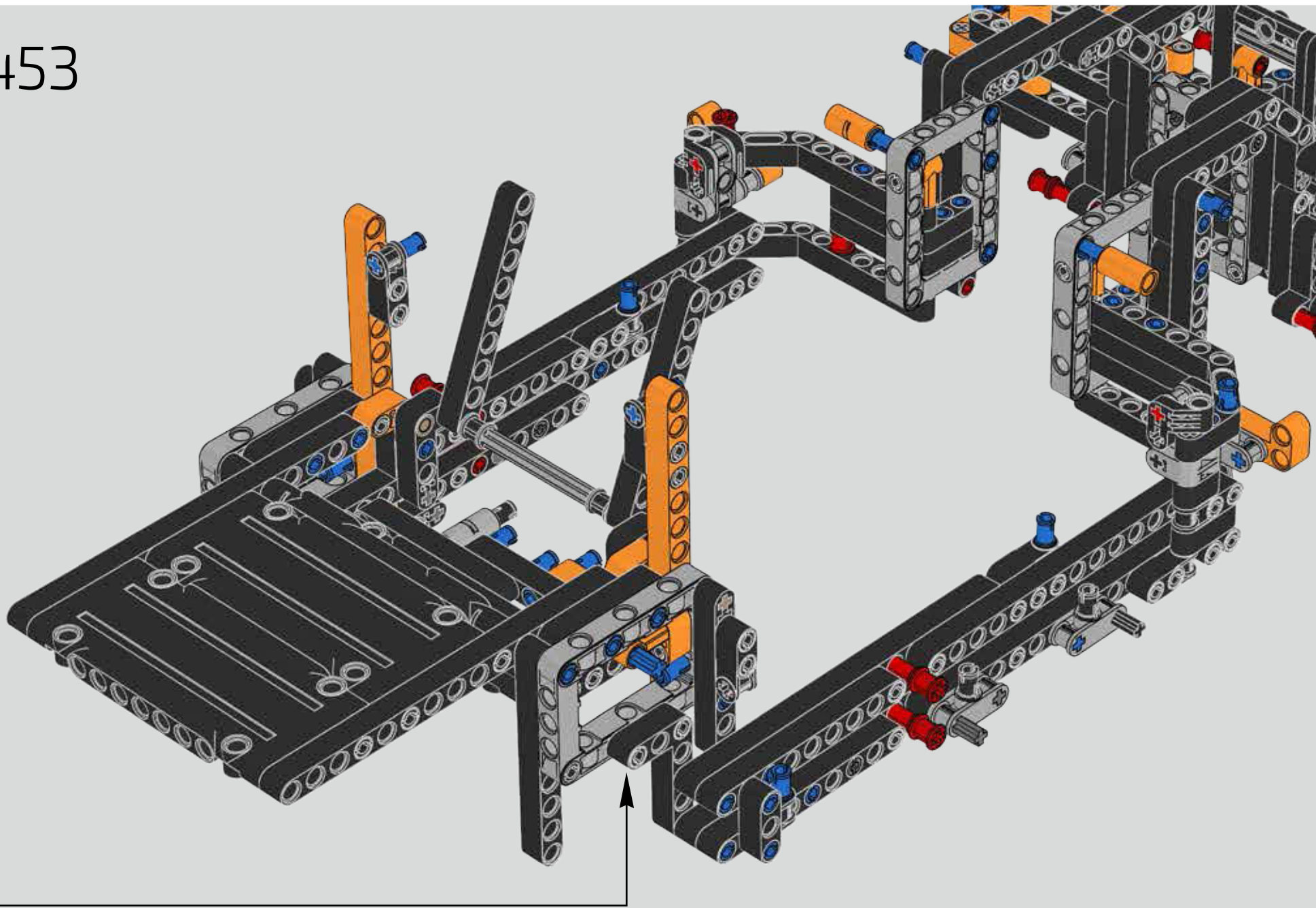

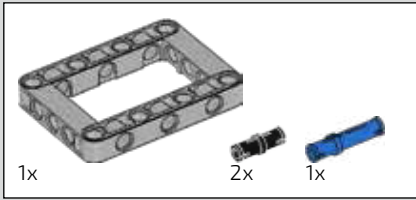
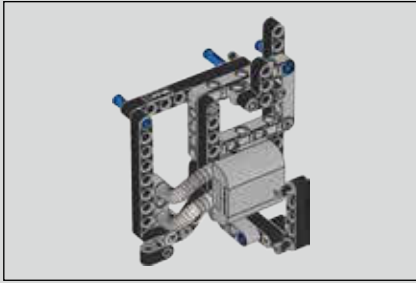

454

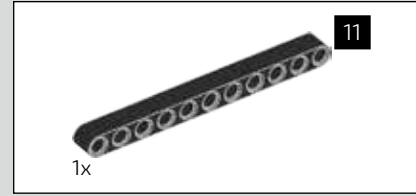
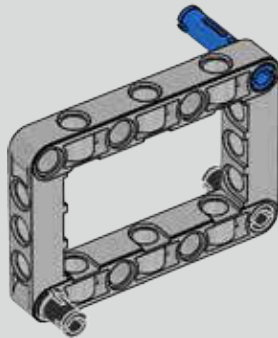

455

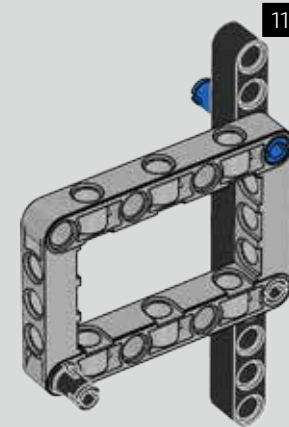

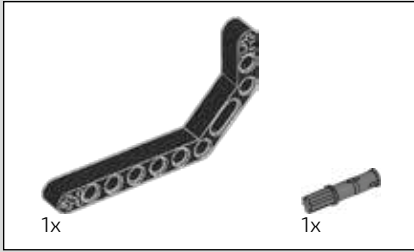

456

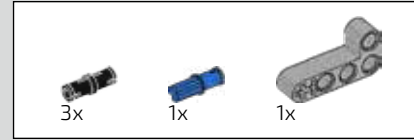
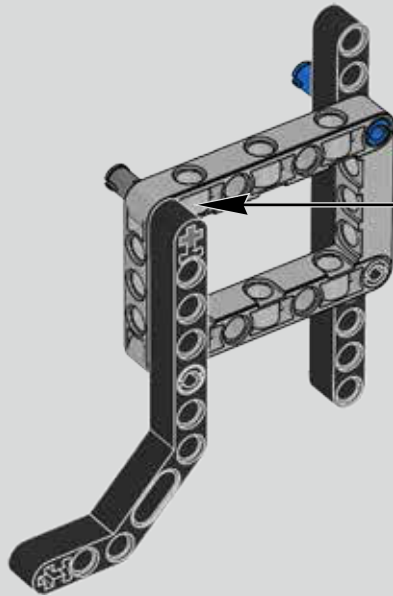
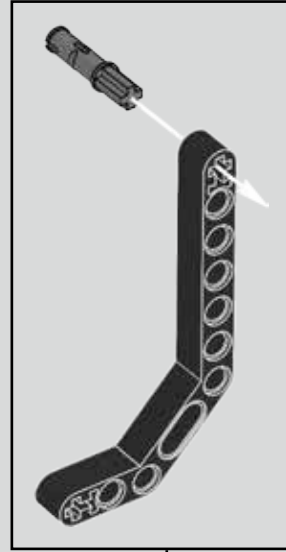

457

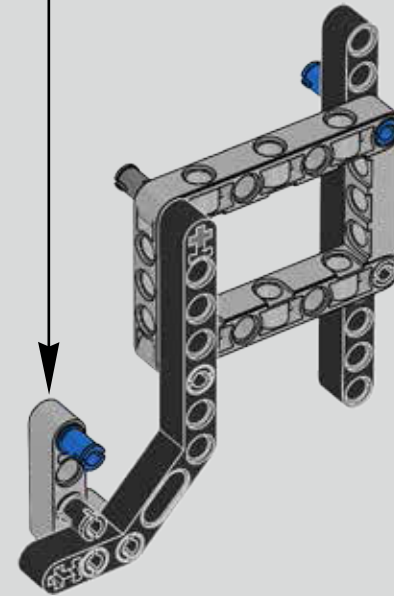
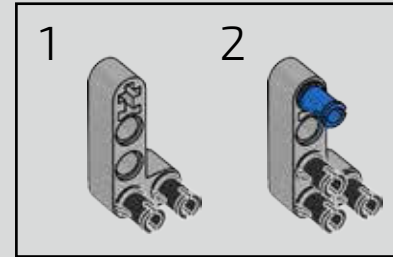

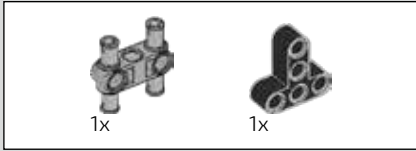

458

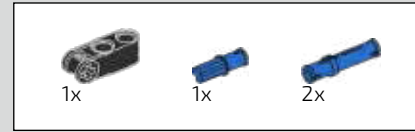
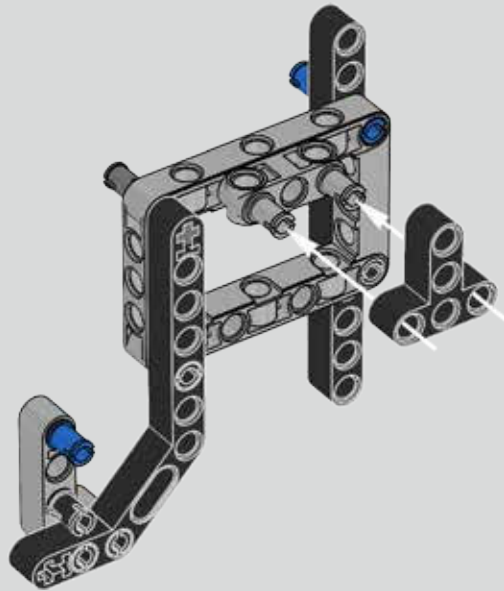

459

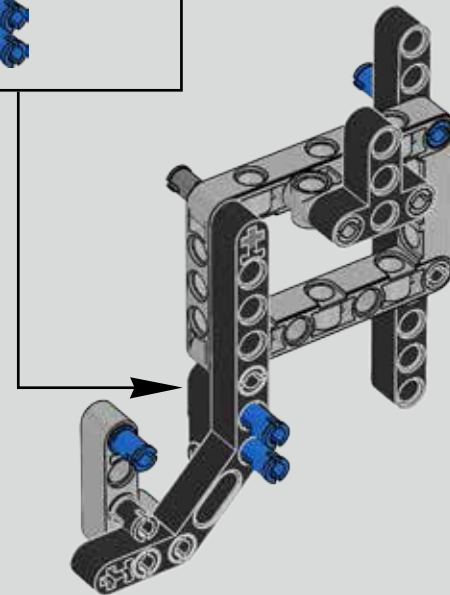
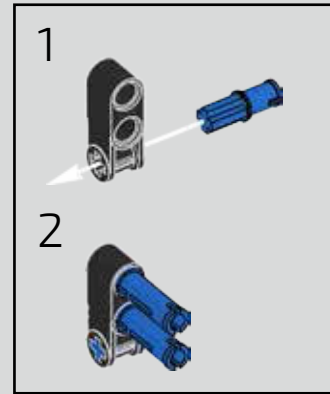



460

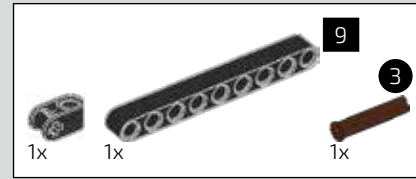
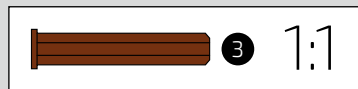
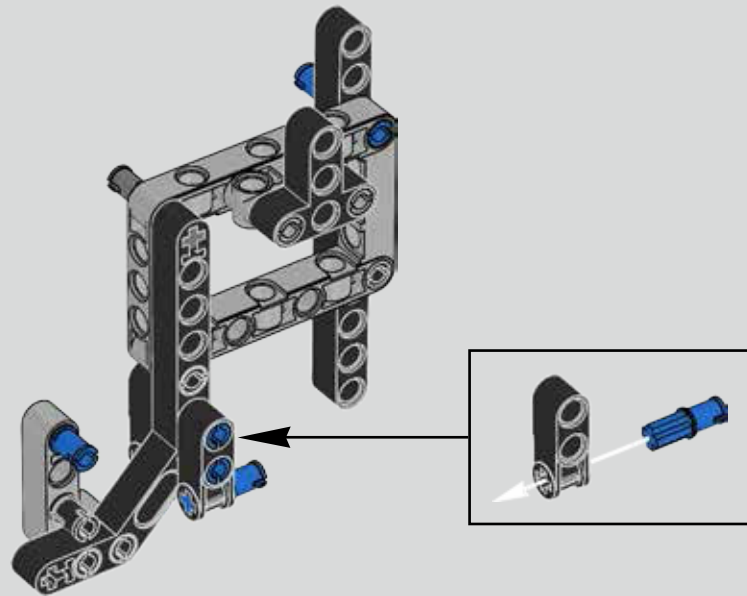

461

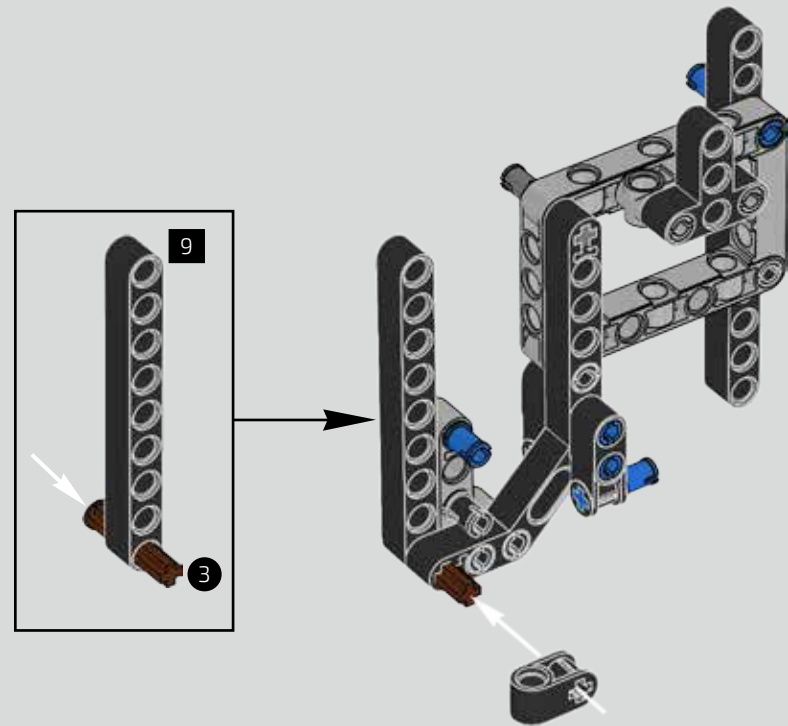

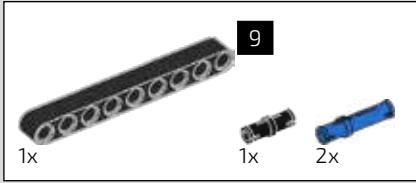

462

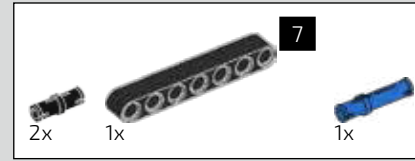
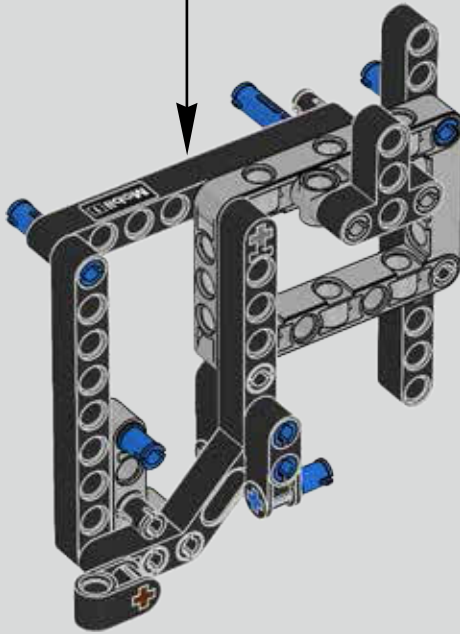
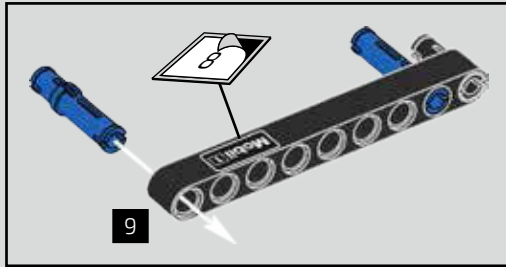

463

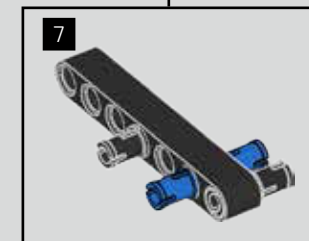
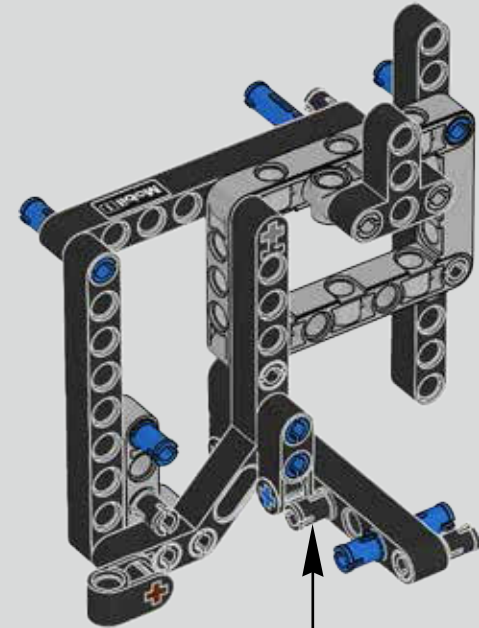

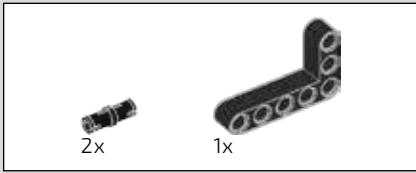

464

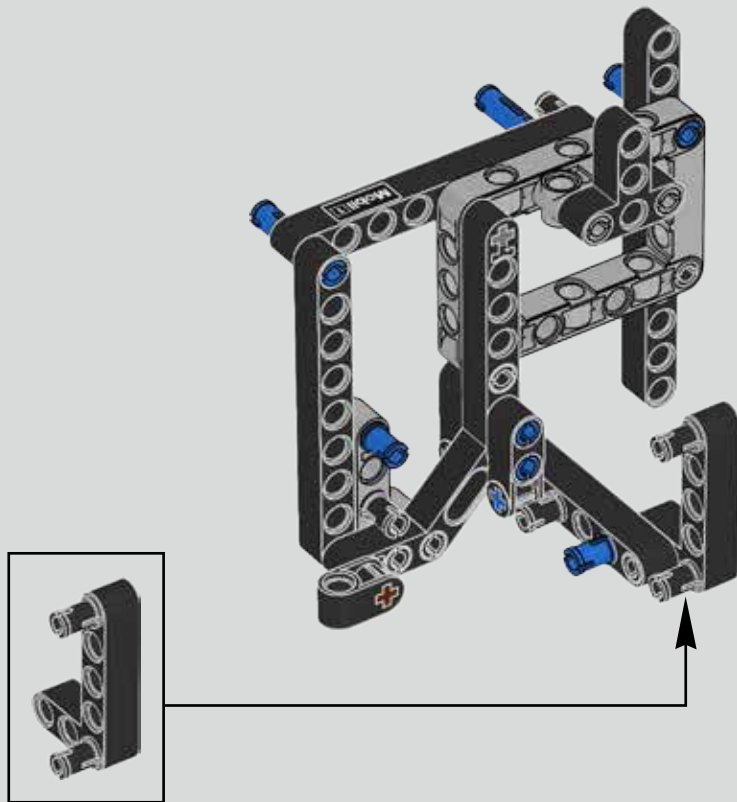

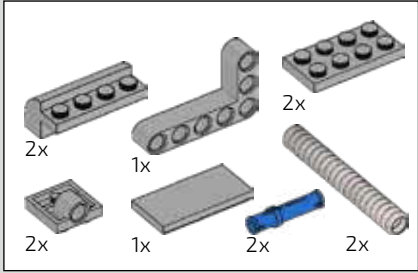
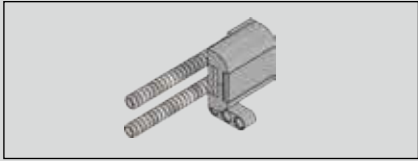

465

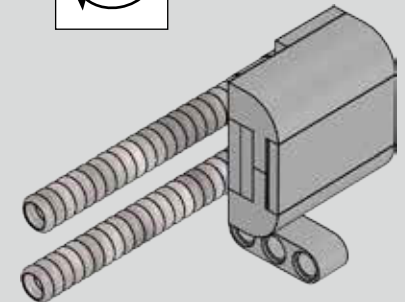
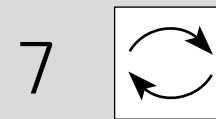
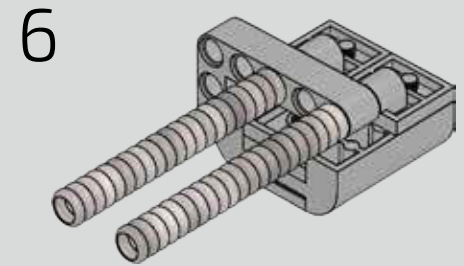
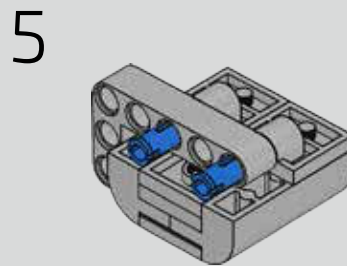
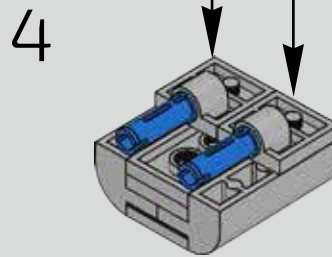
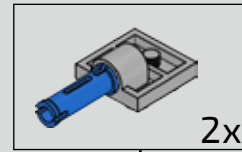
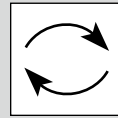
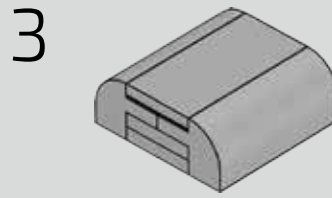
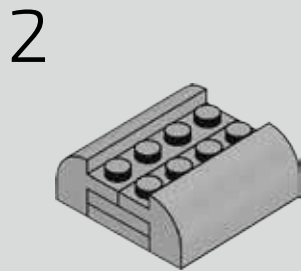
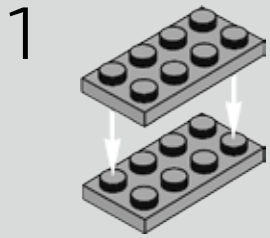

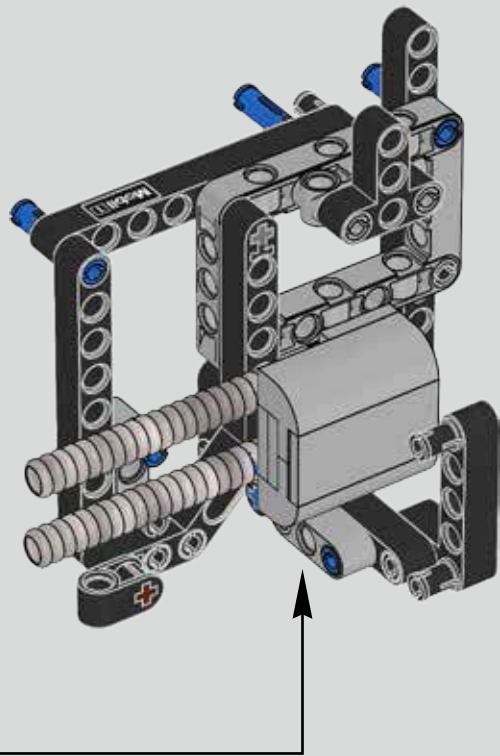

466

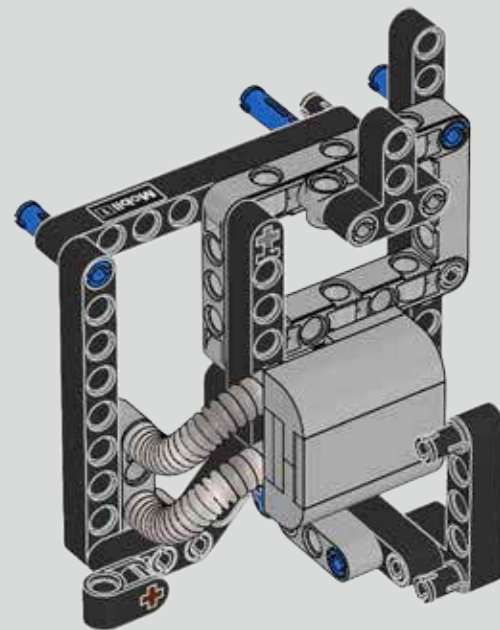

467

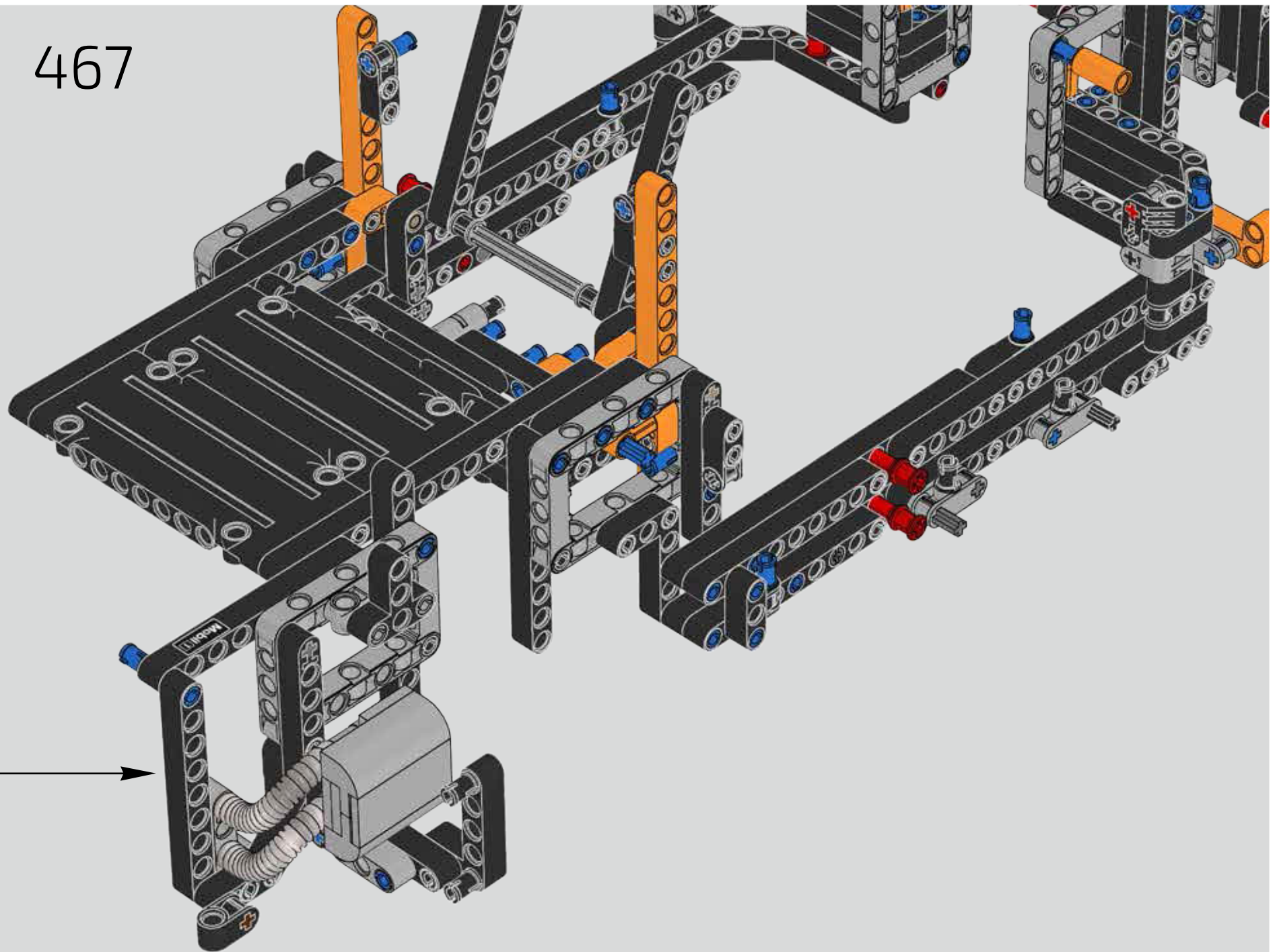

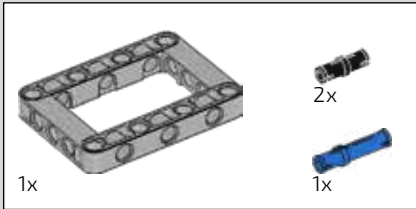
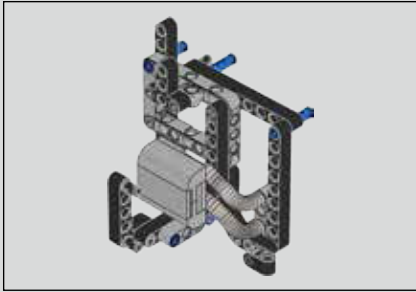

468

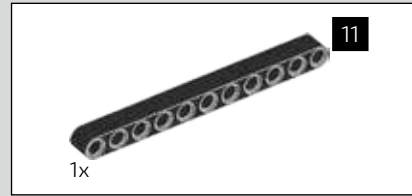
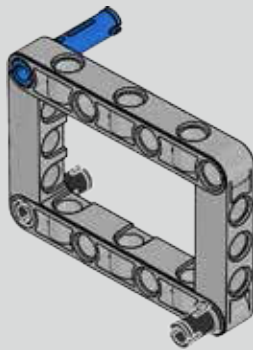

469

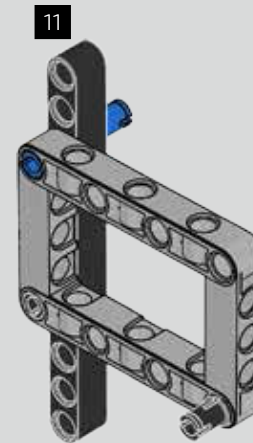

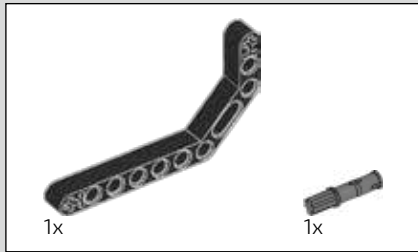

470

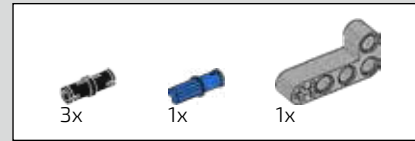
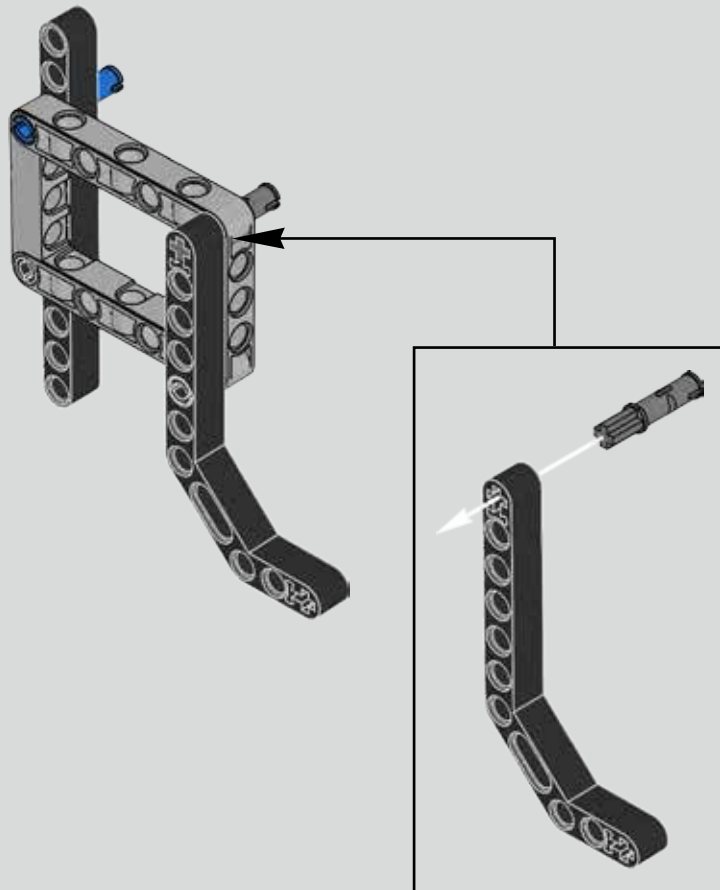

471

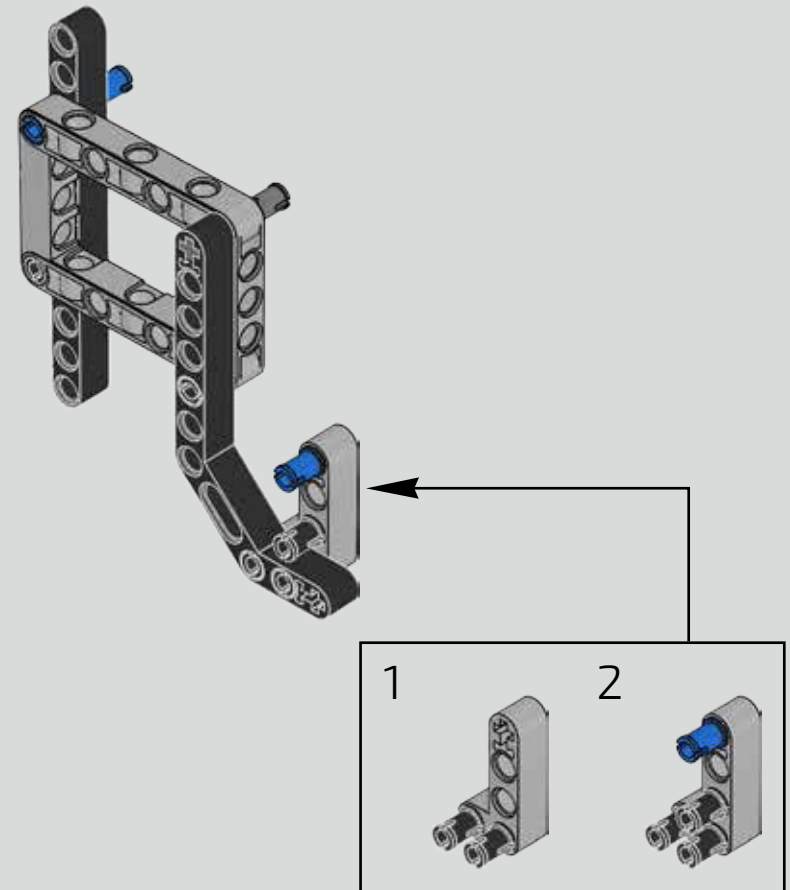

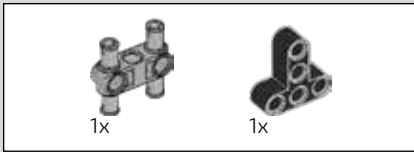

472

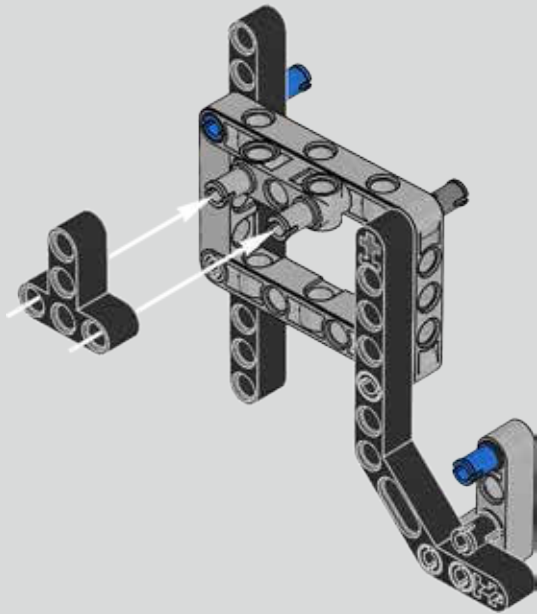

473

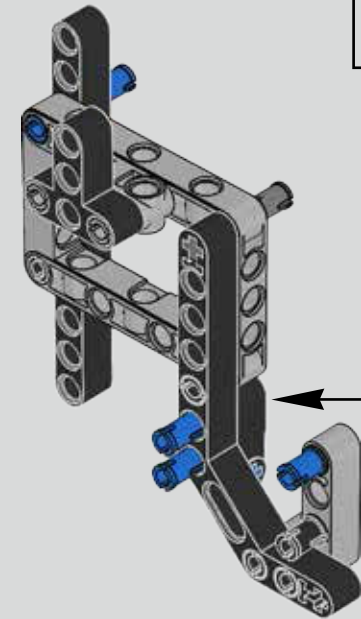
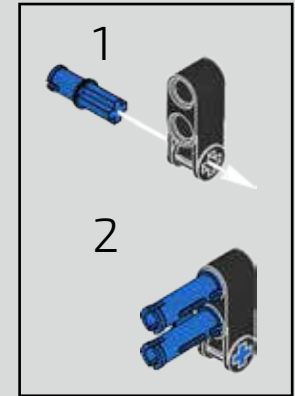



474

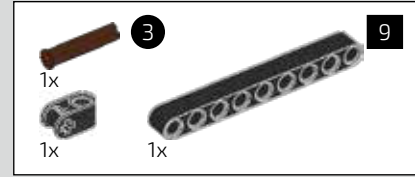
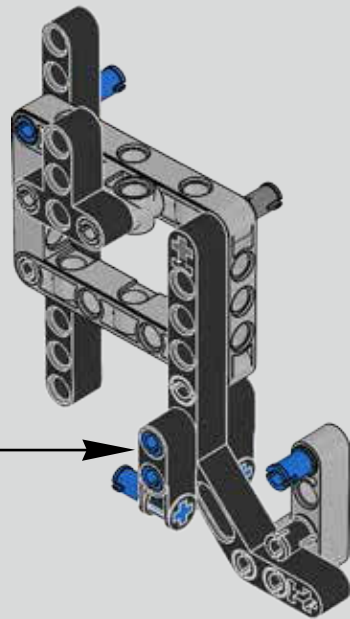
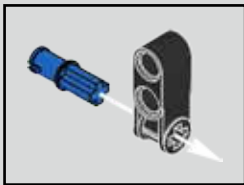

475

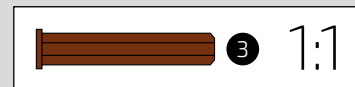
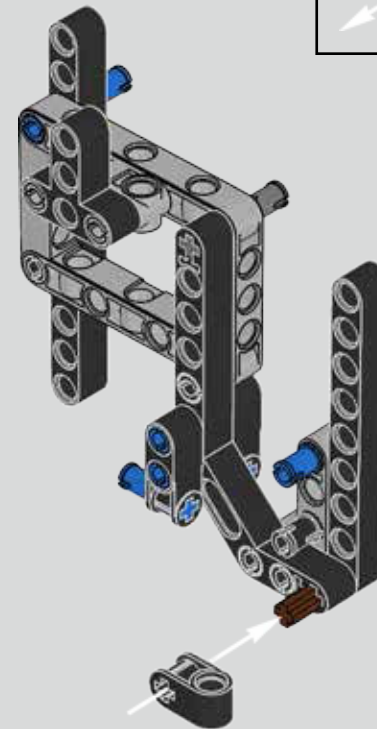
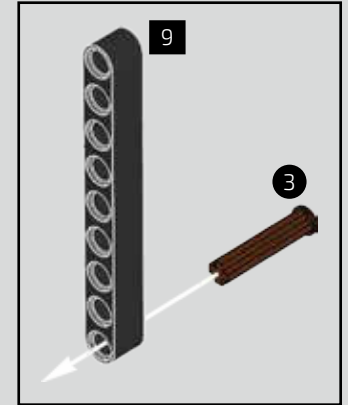

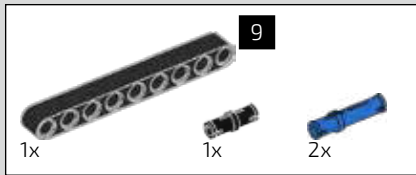

476

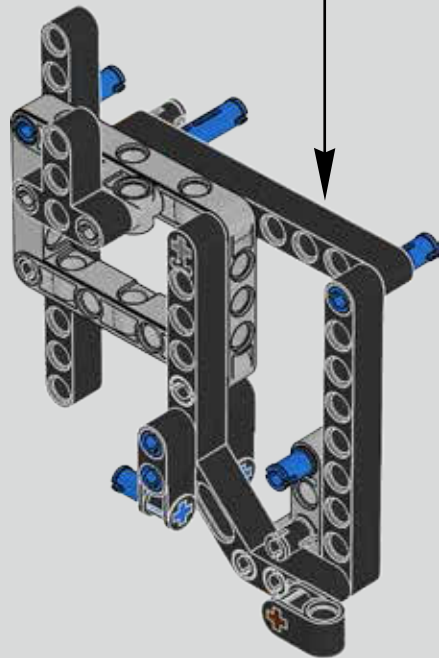
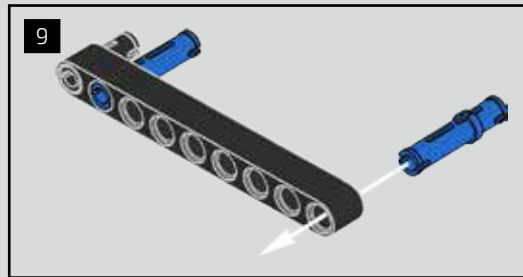

477

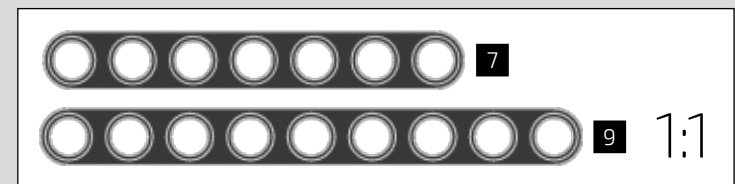
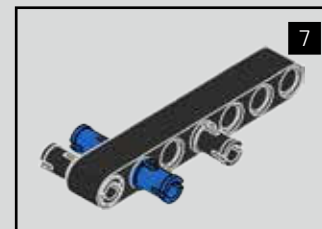
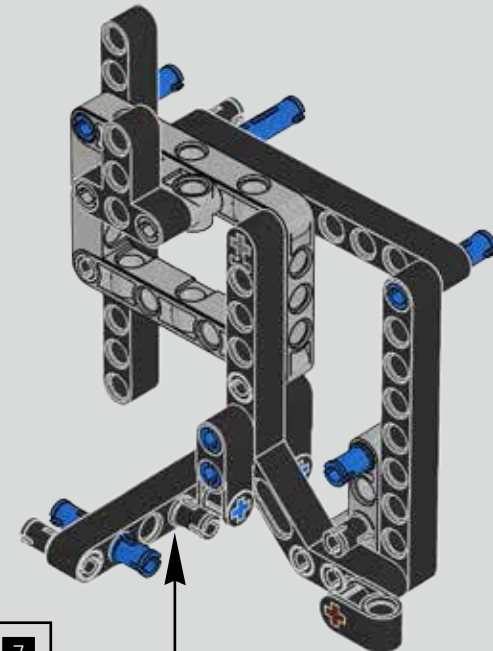

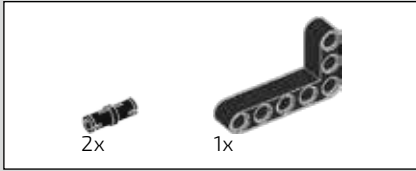

478

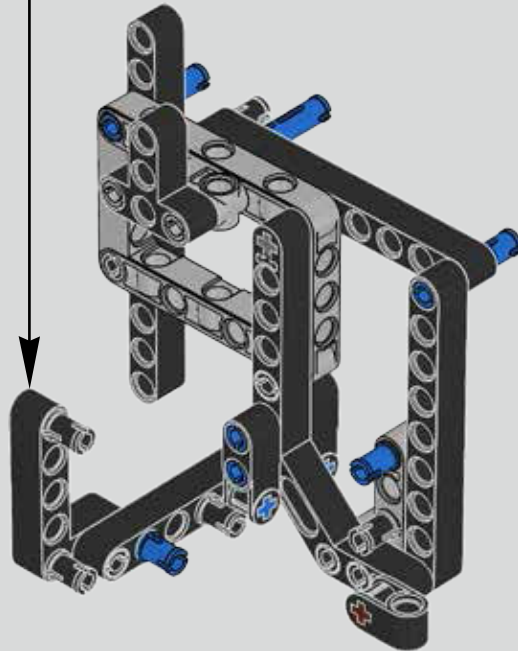
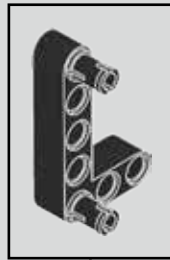

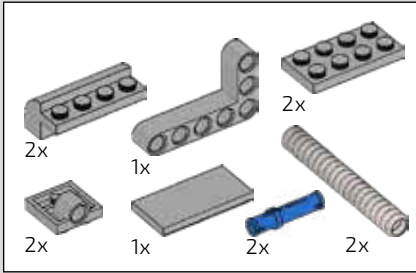
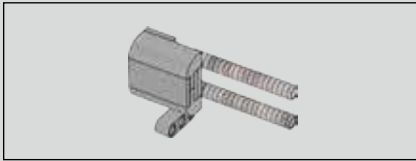

479

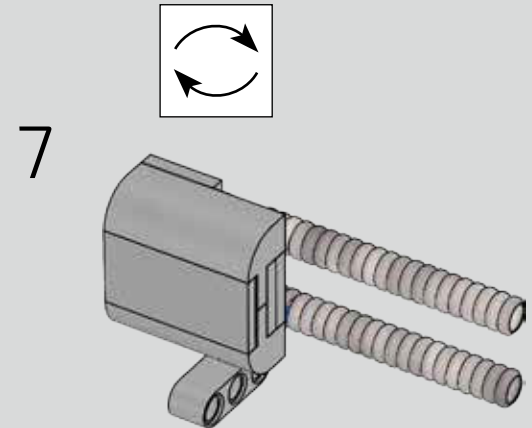
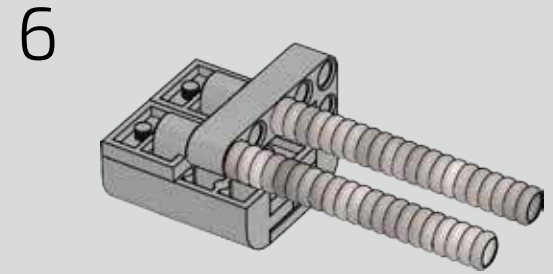
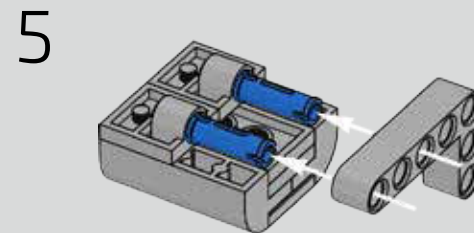
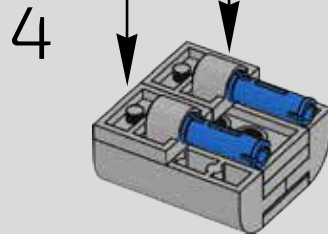
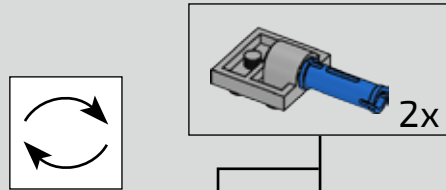
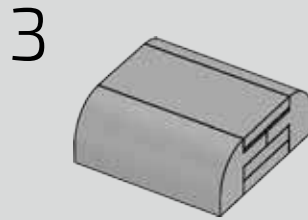
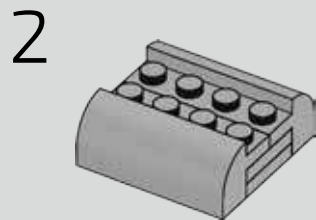
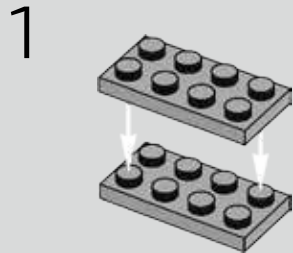

480

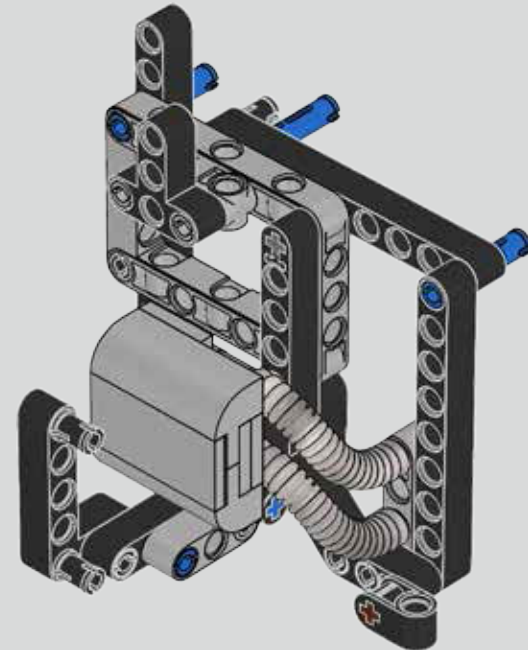
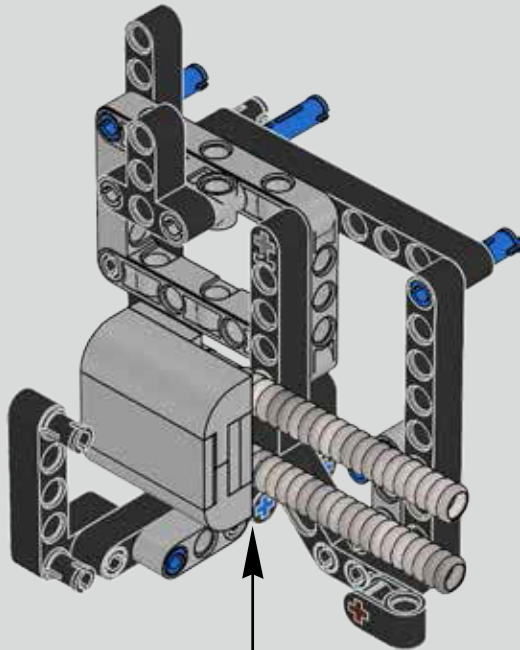

481

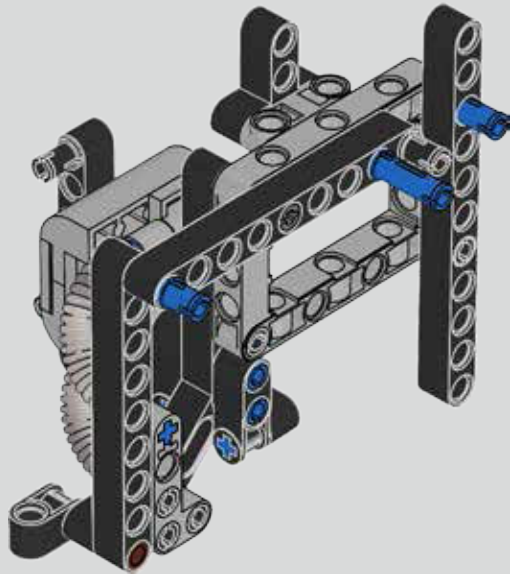
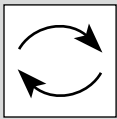

482

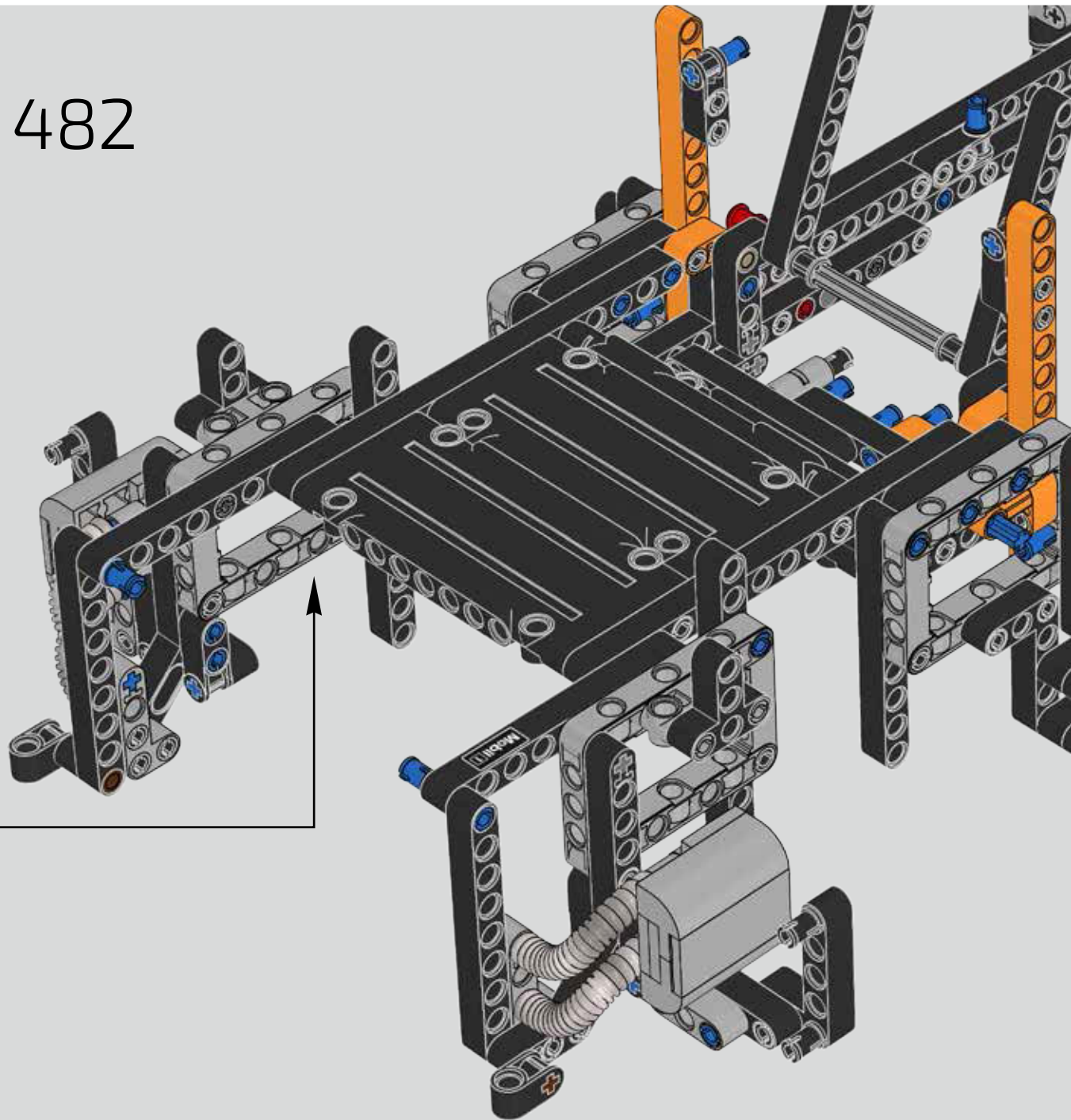

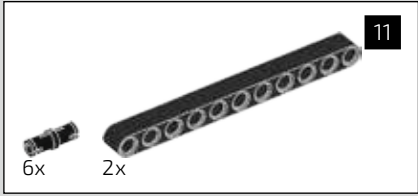

483

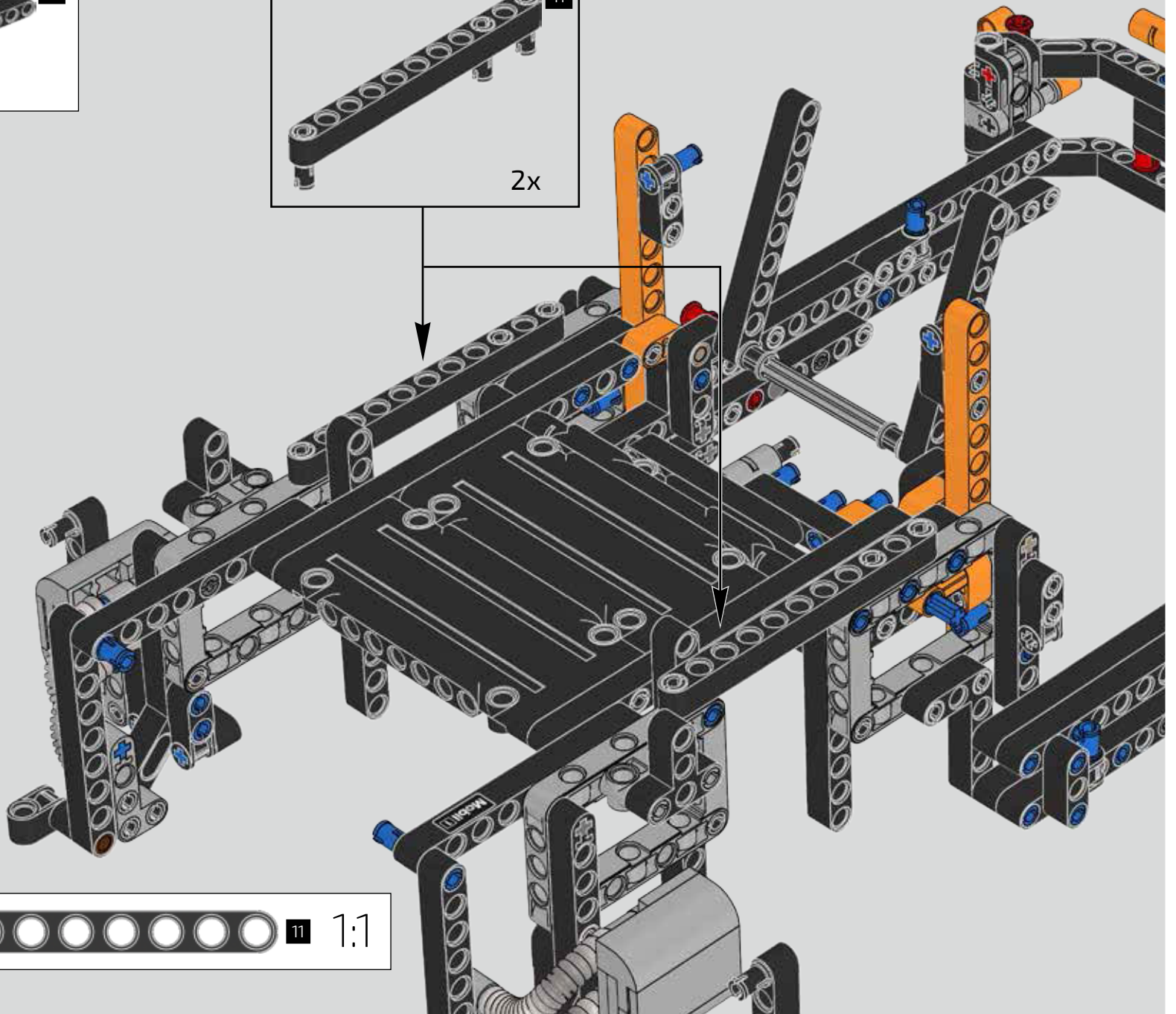
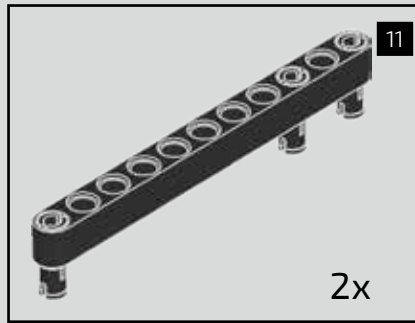



484

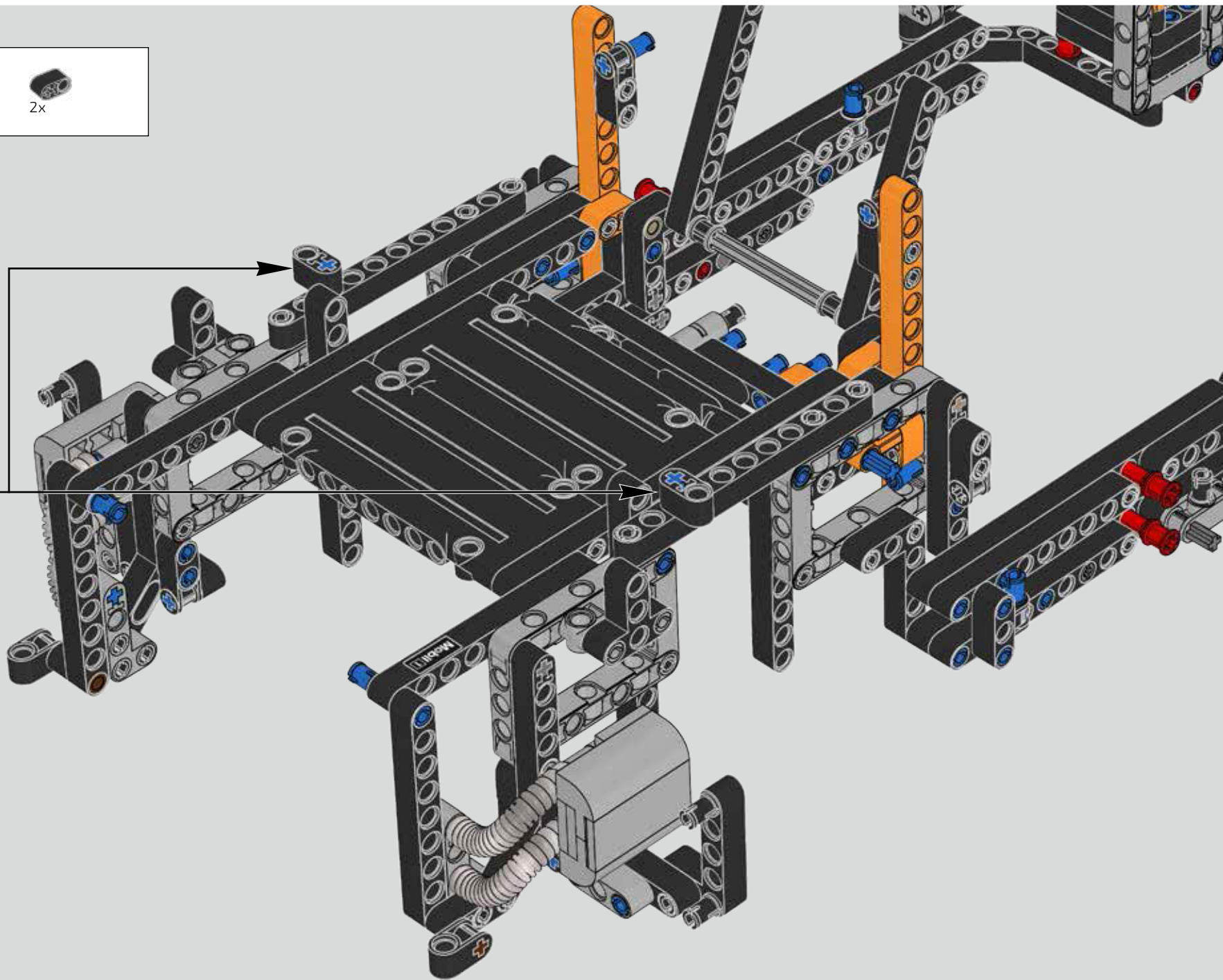
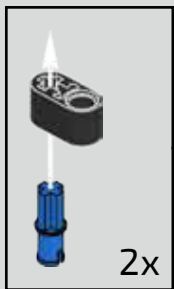

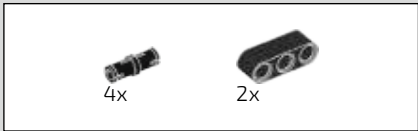

485

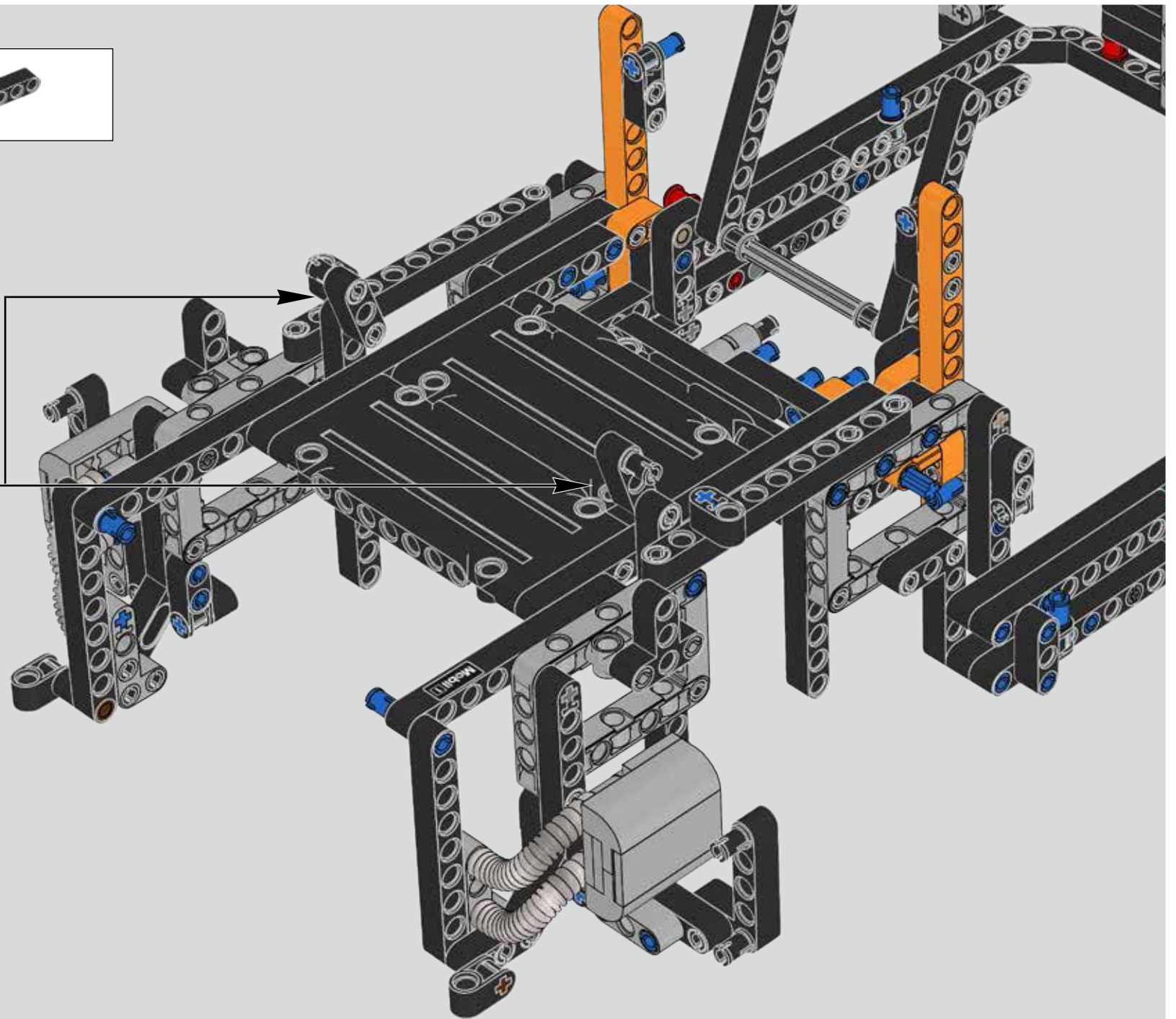
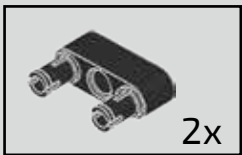



486

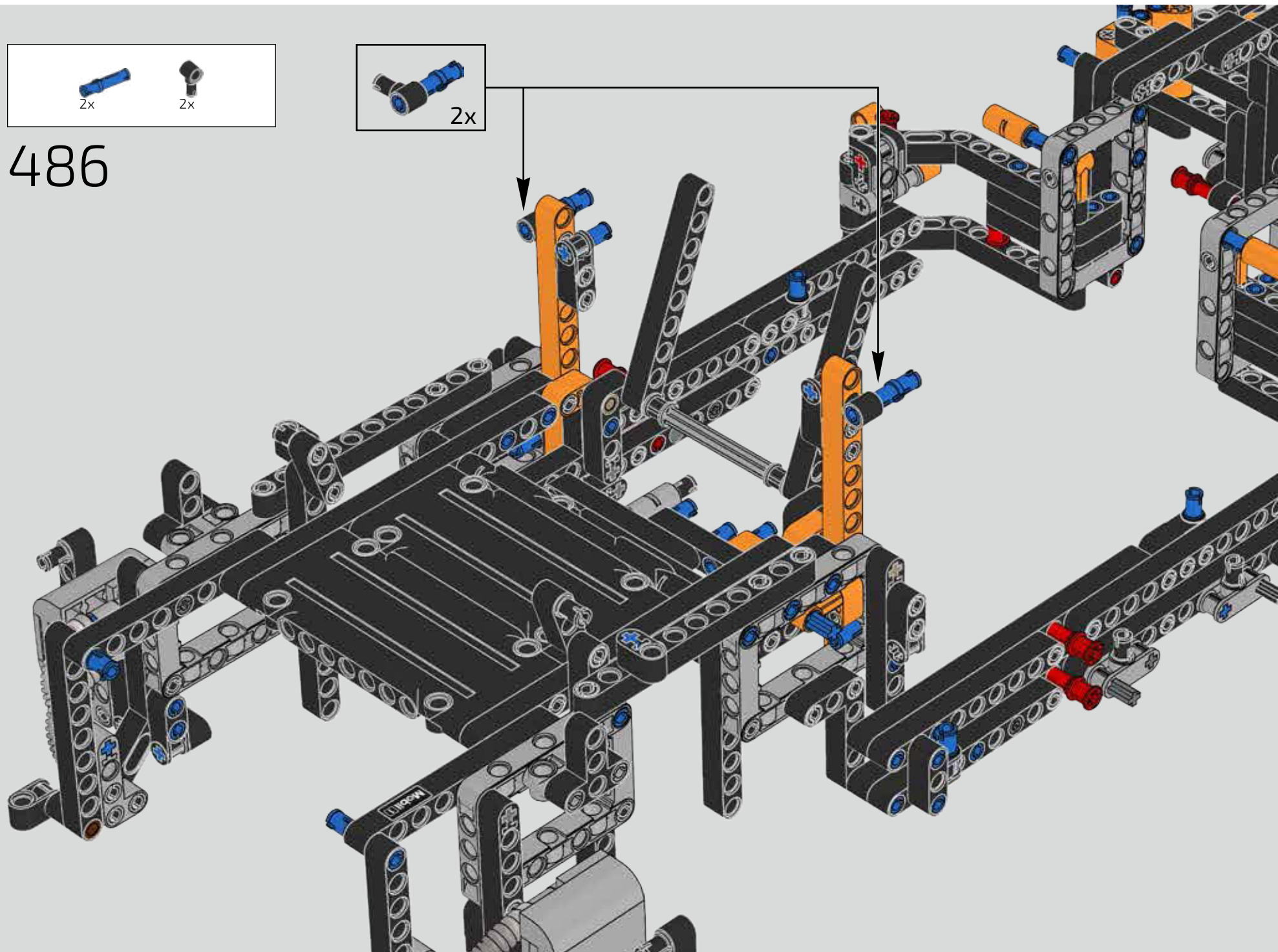

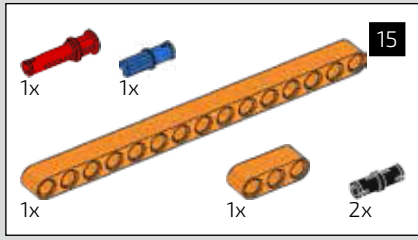

487

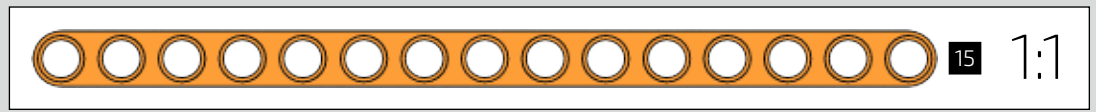
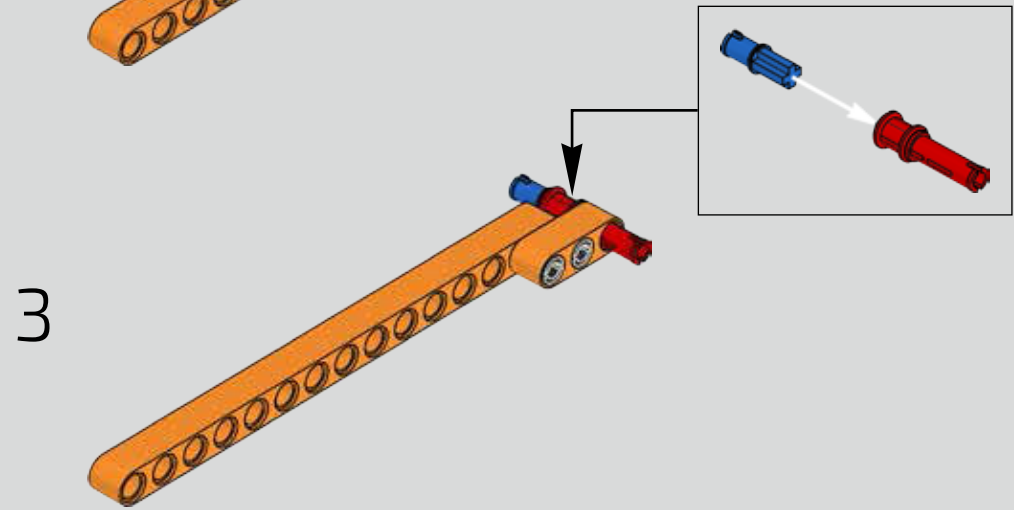
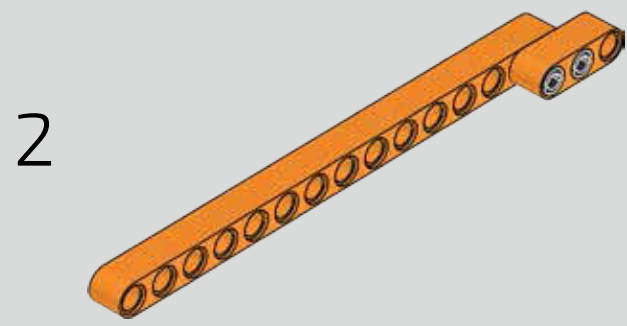
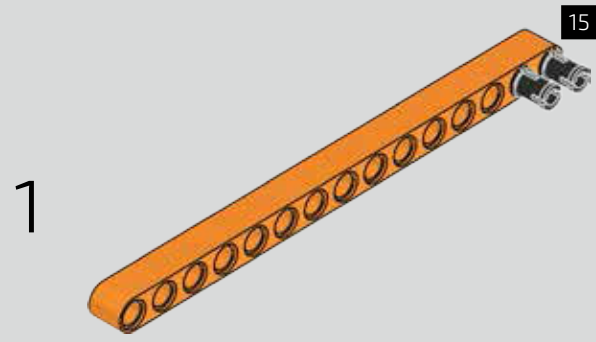

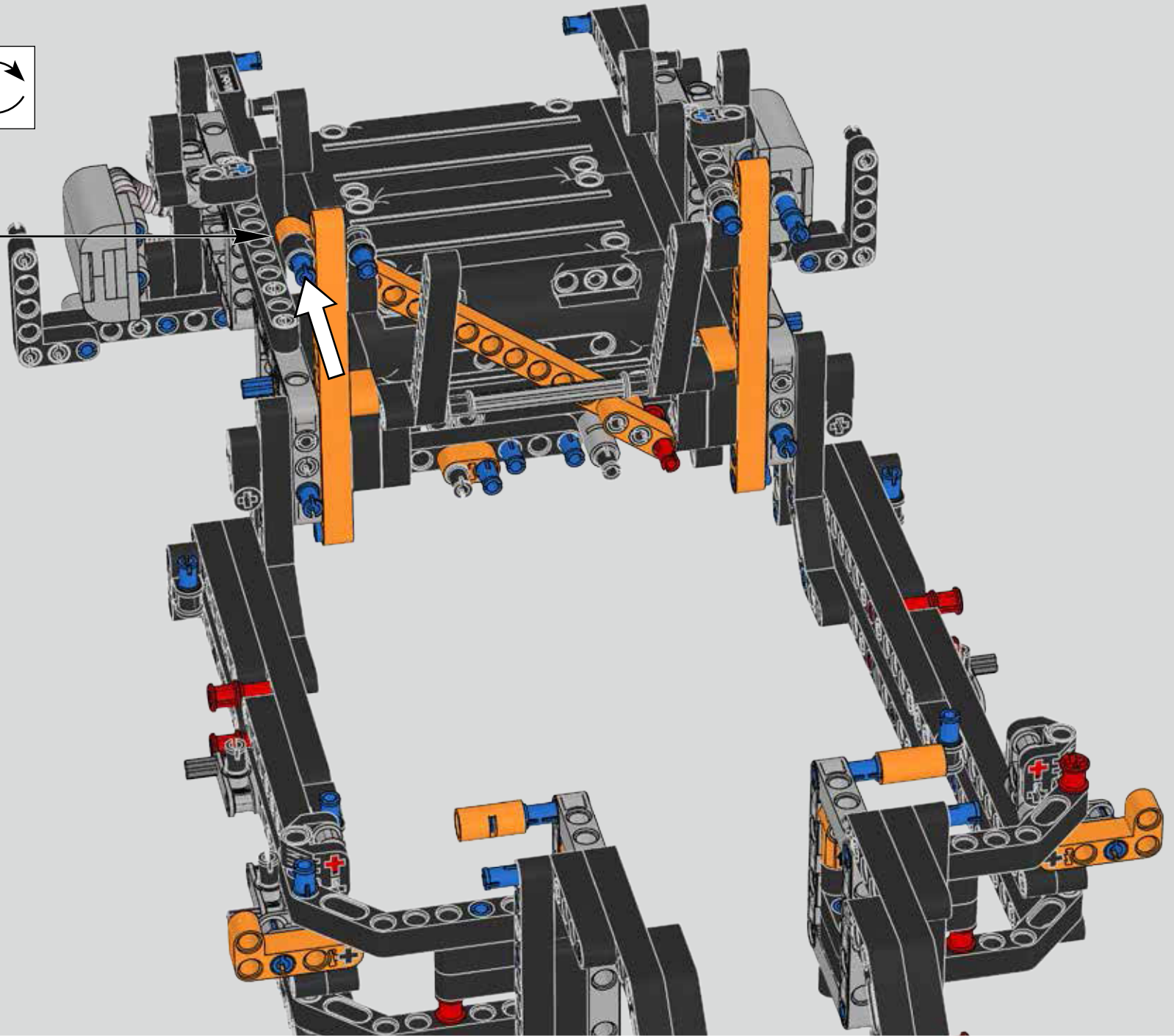
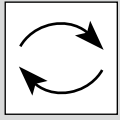

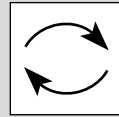
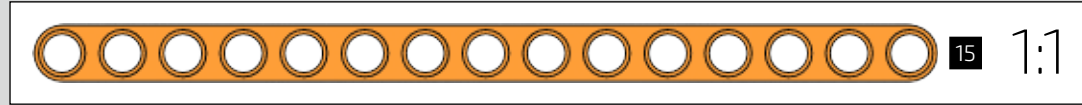
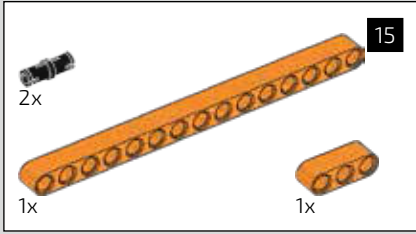

488

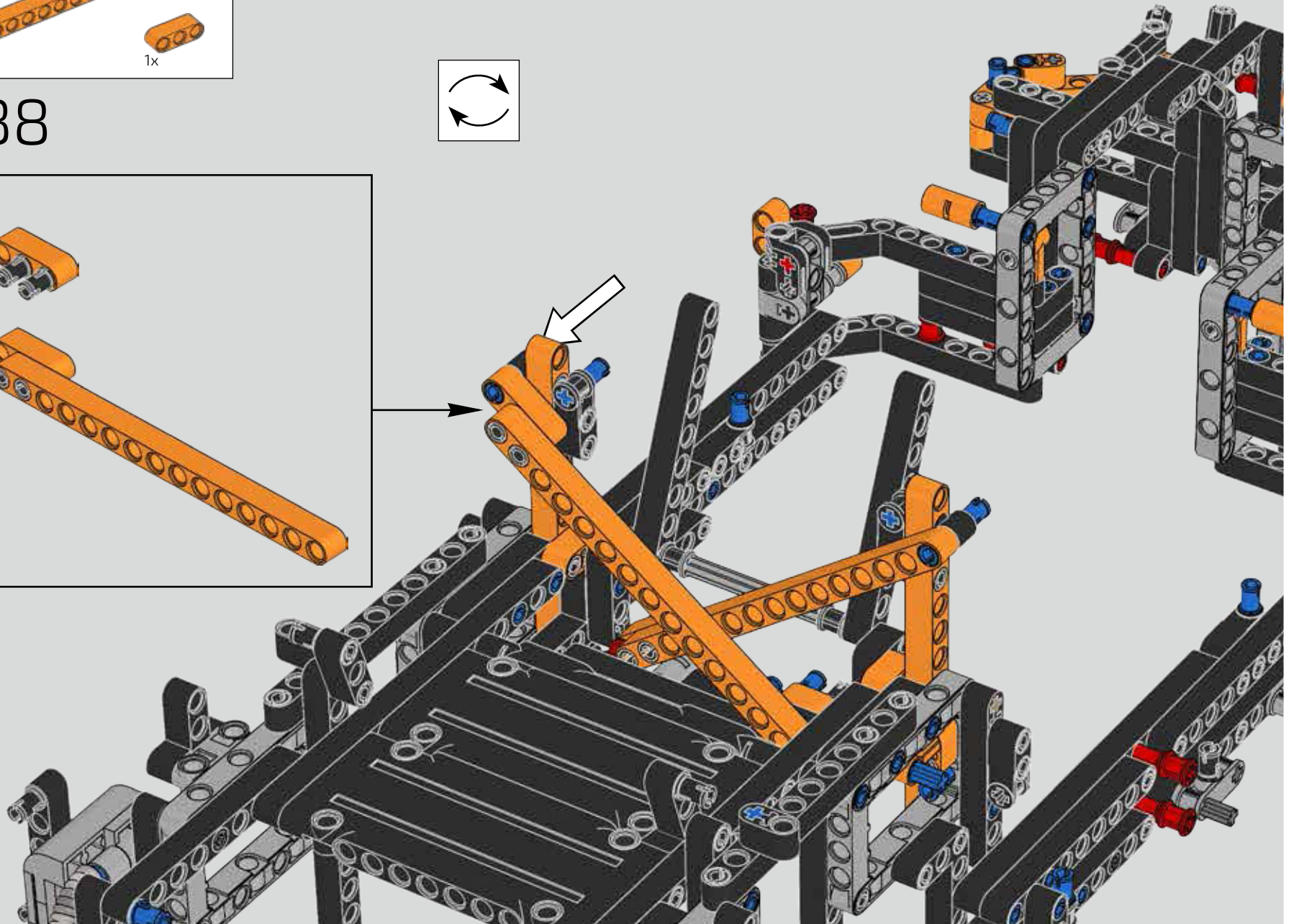
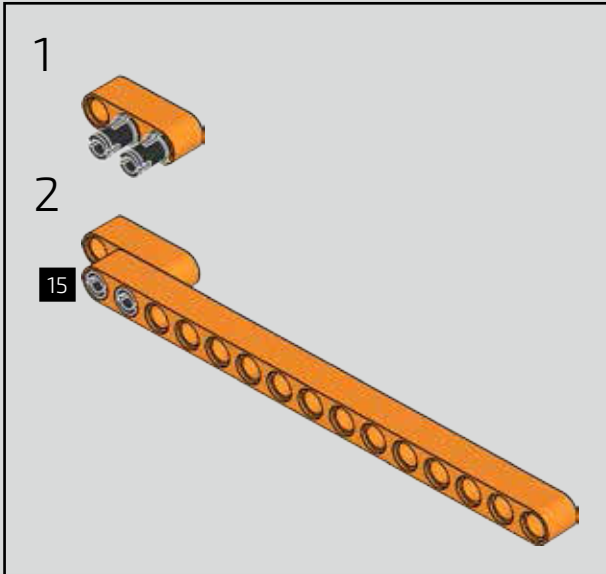

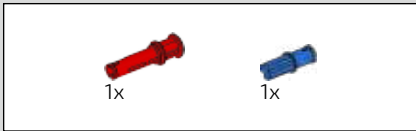

489

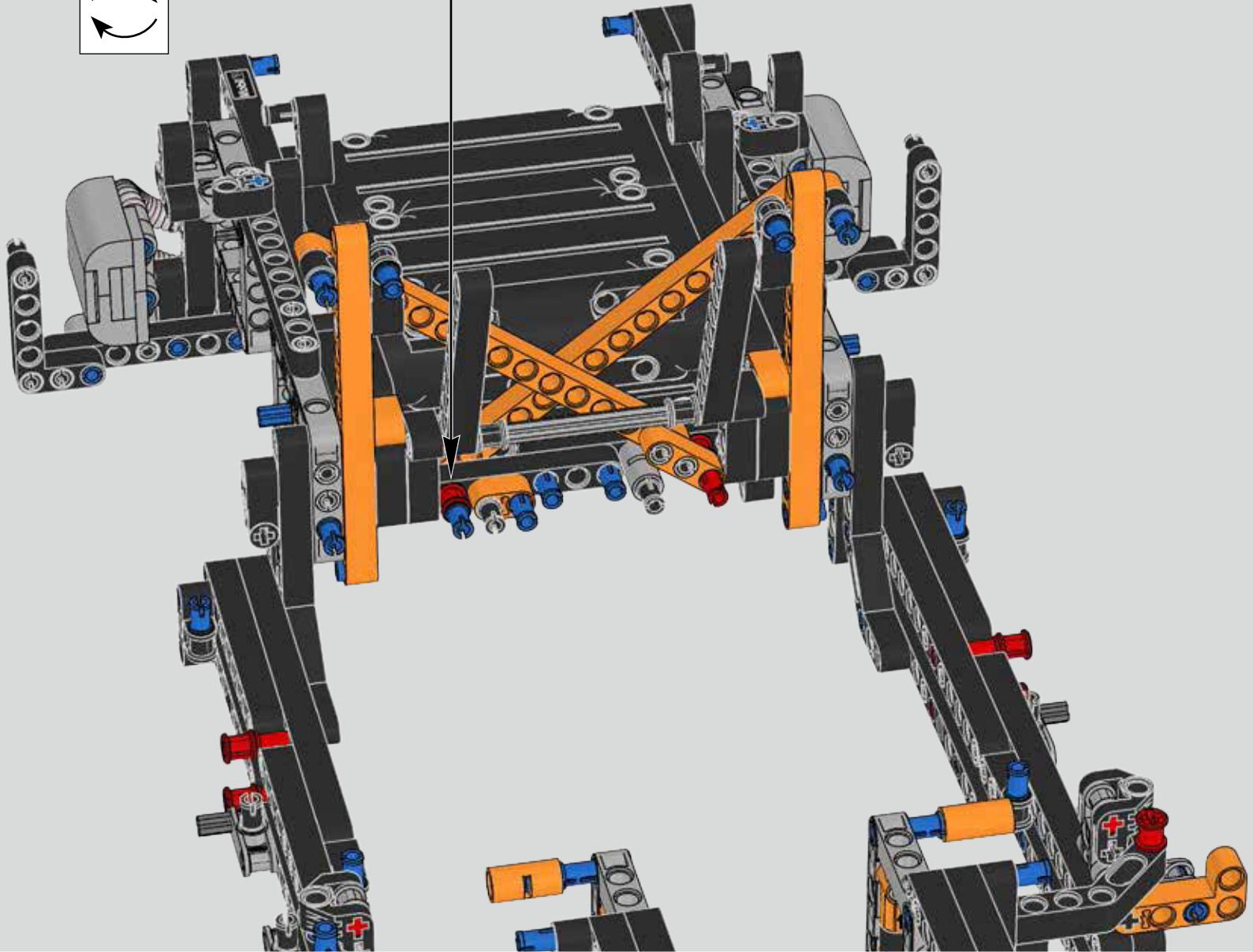
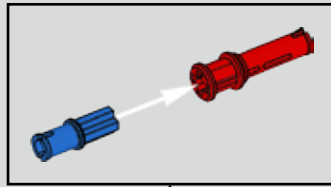
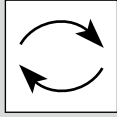

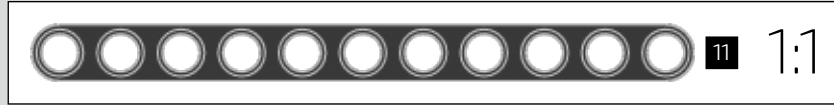
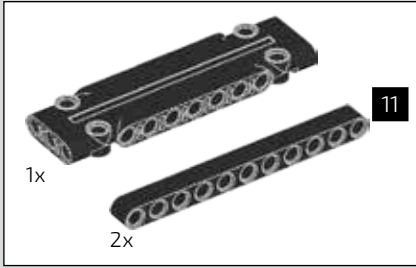

490

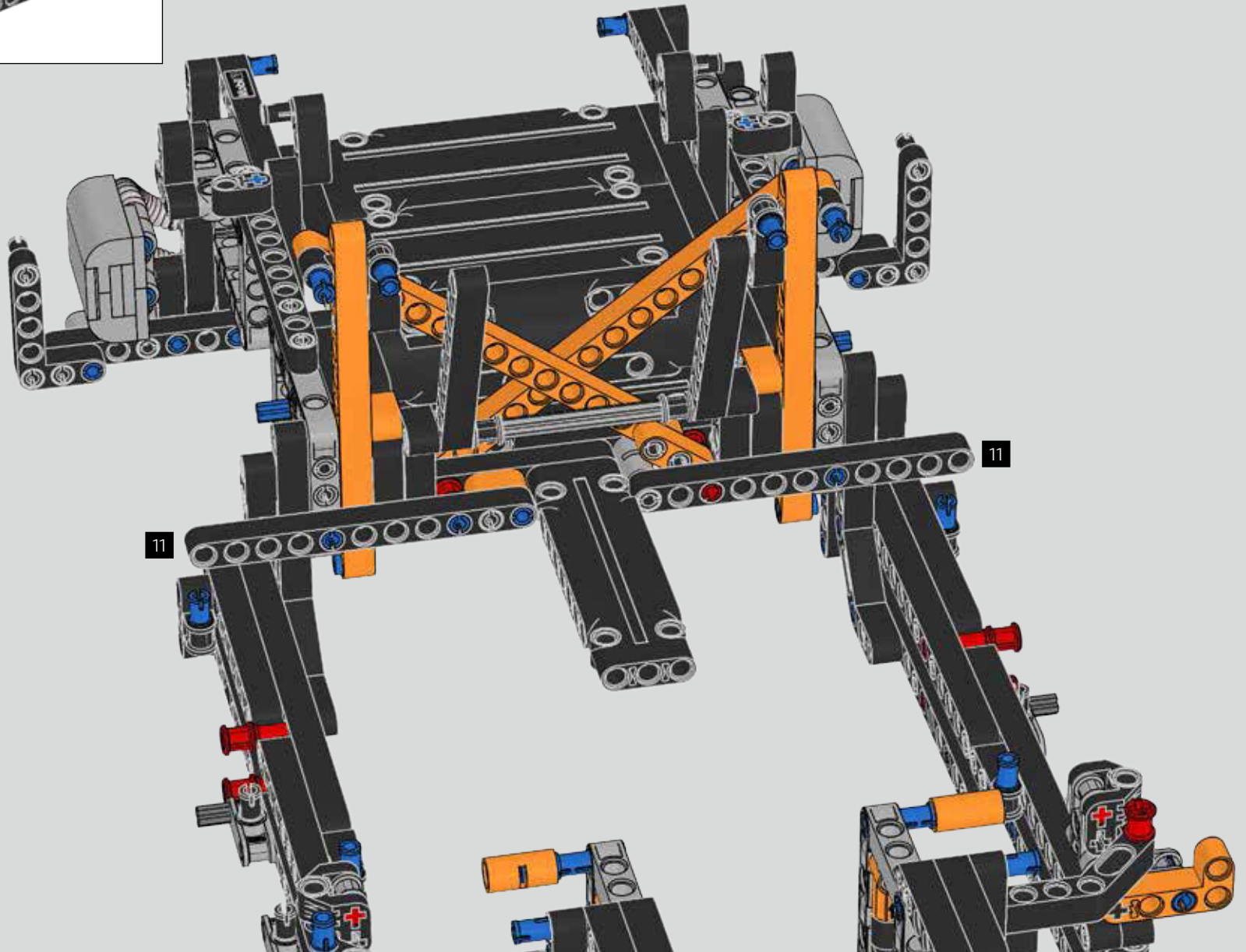

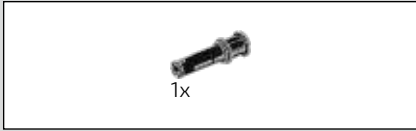

491

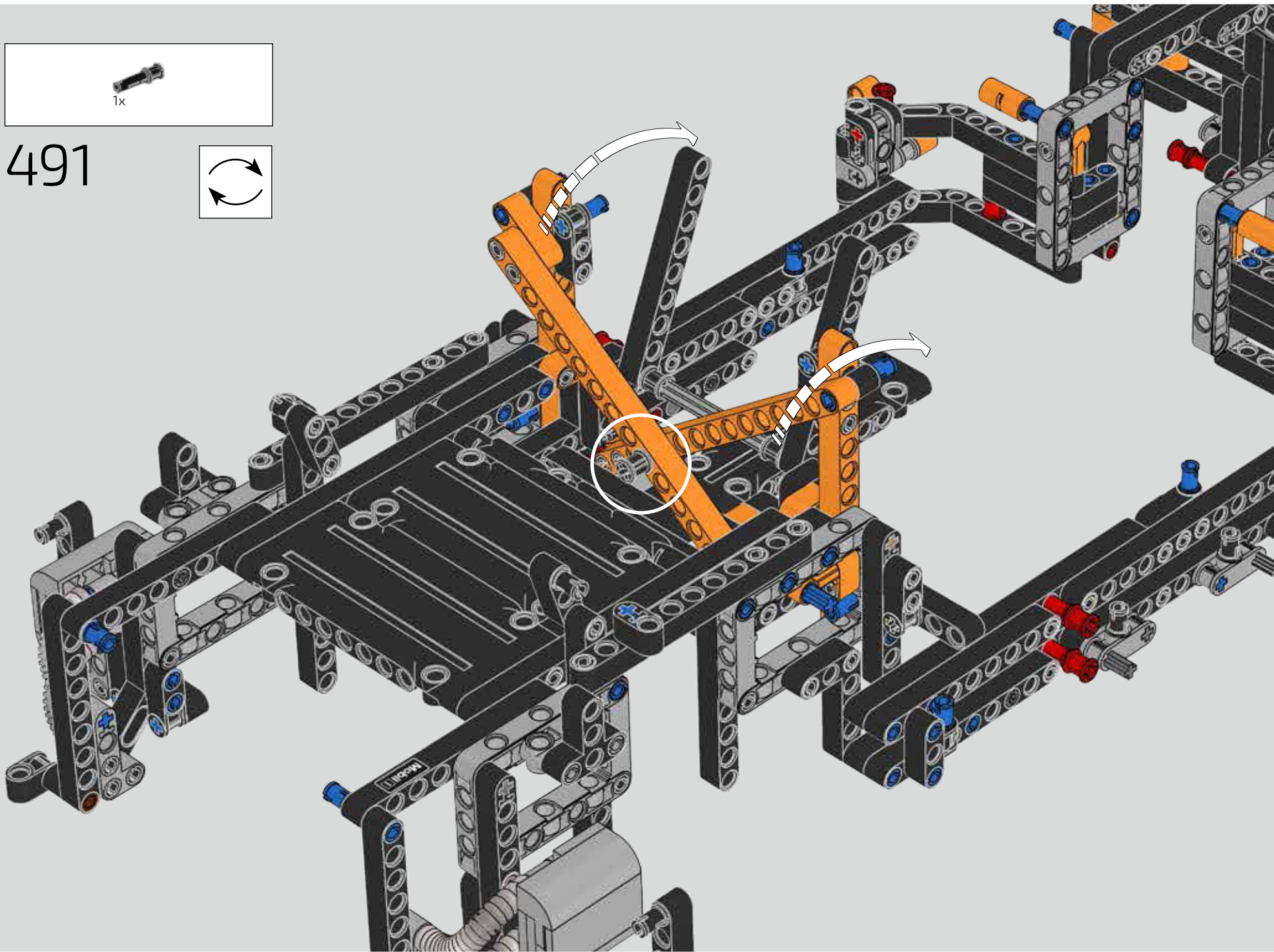
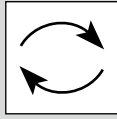

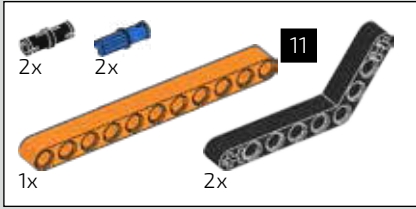

492

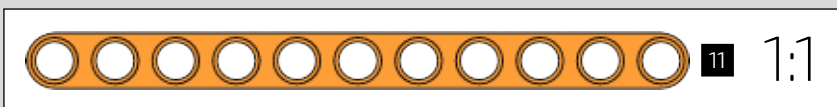
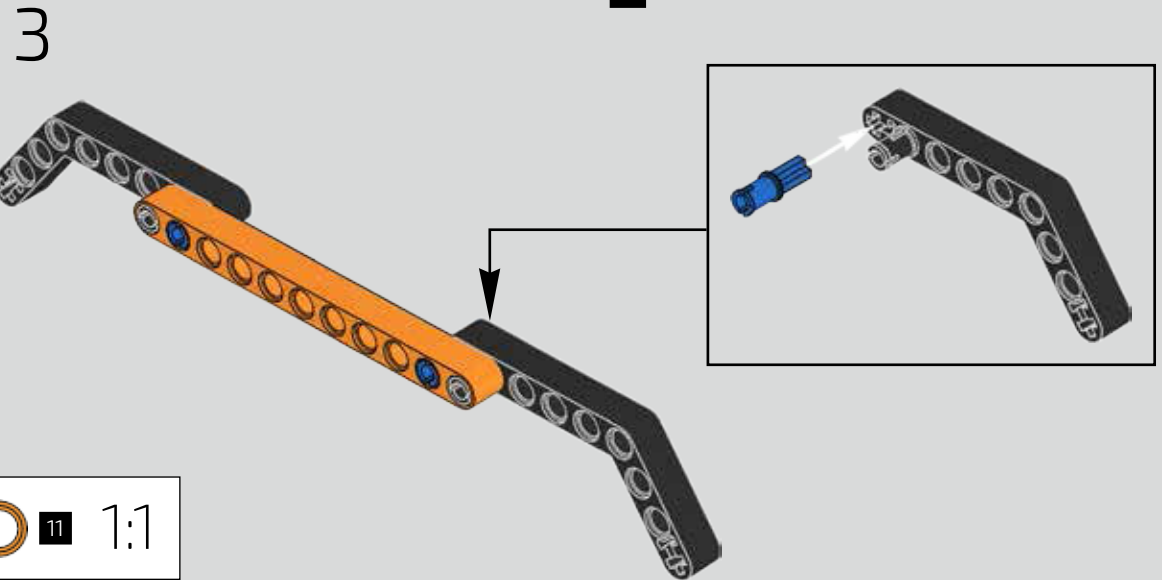
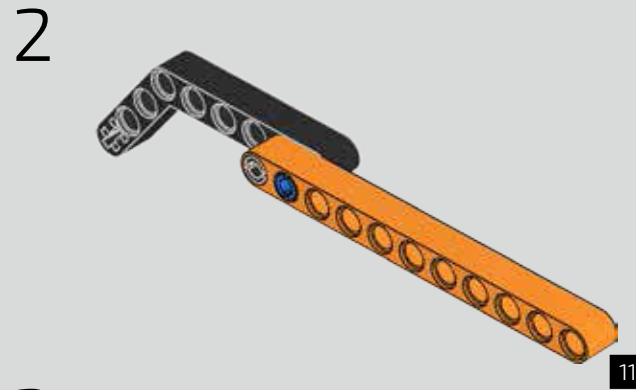

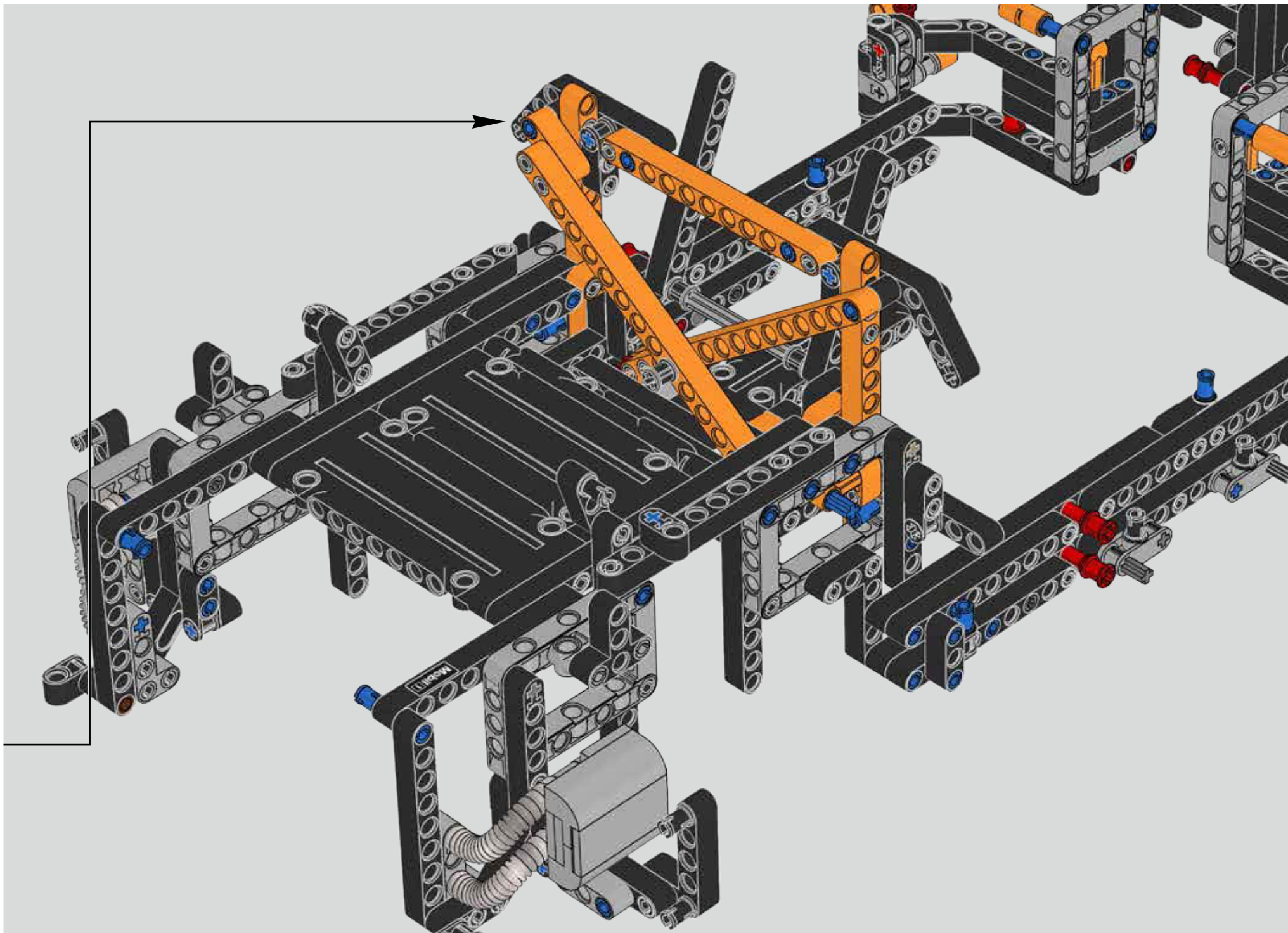

493

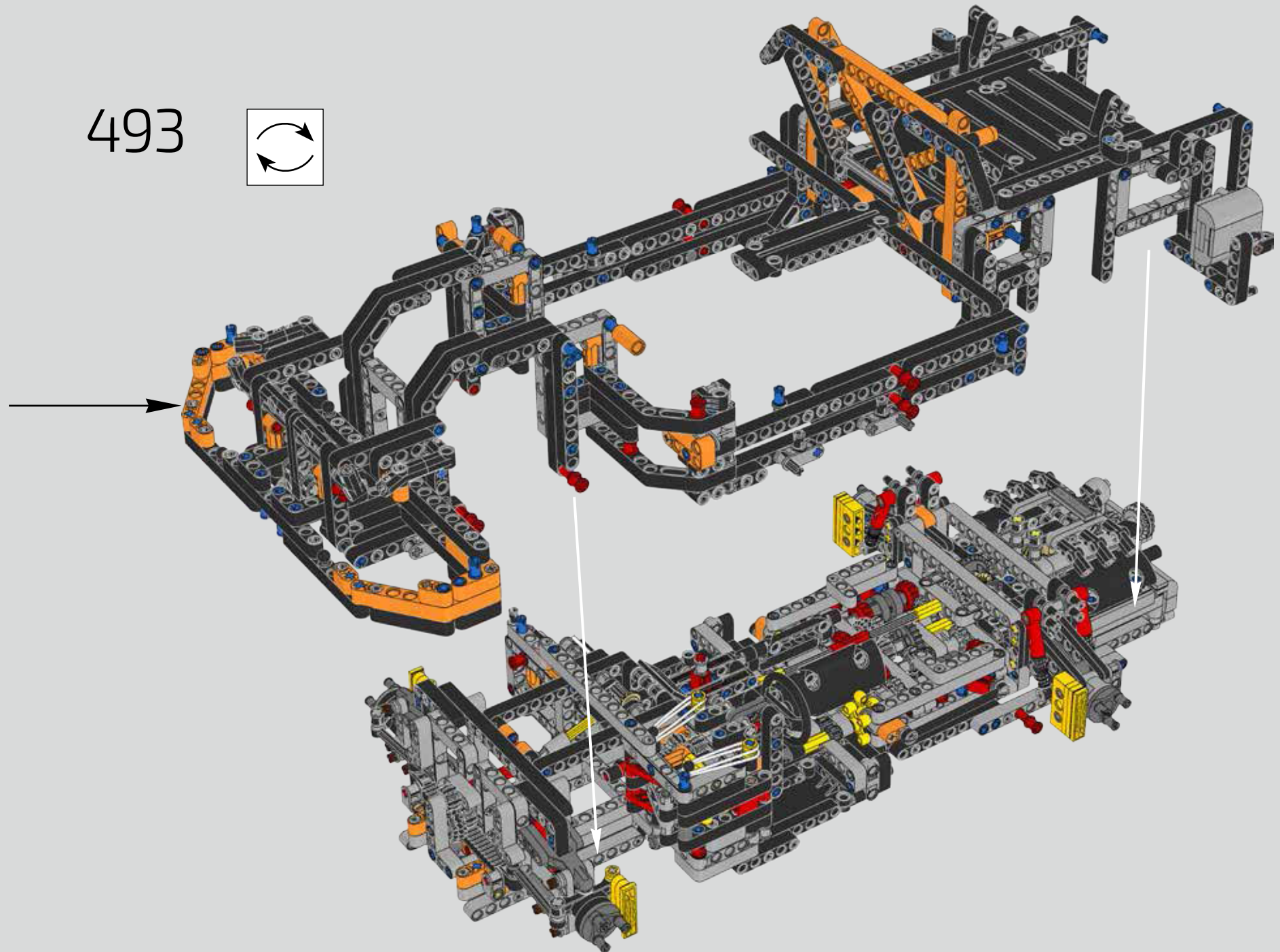
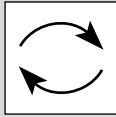

494

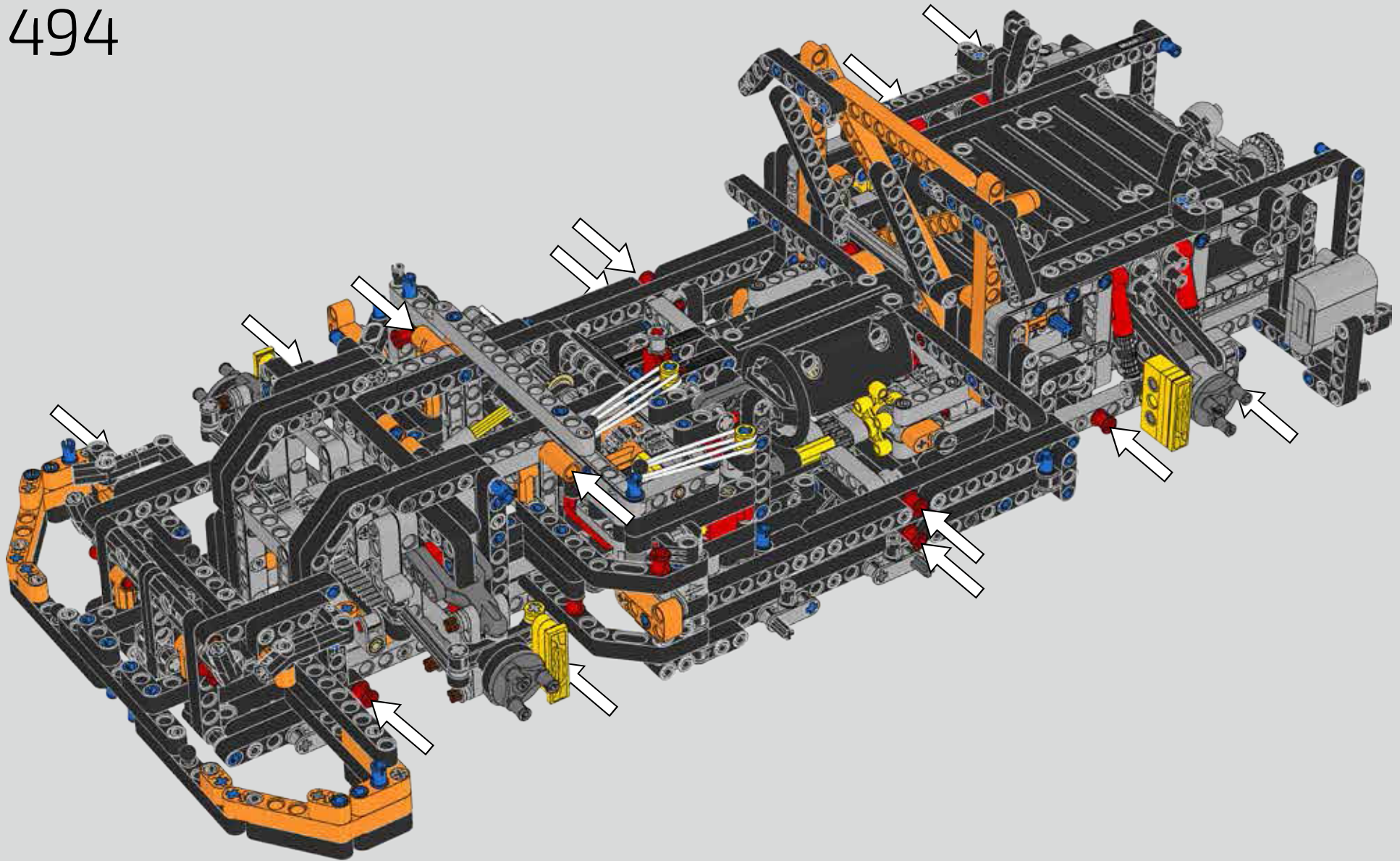

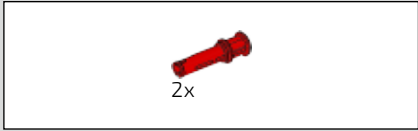

495

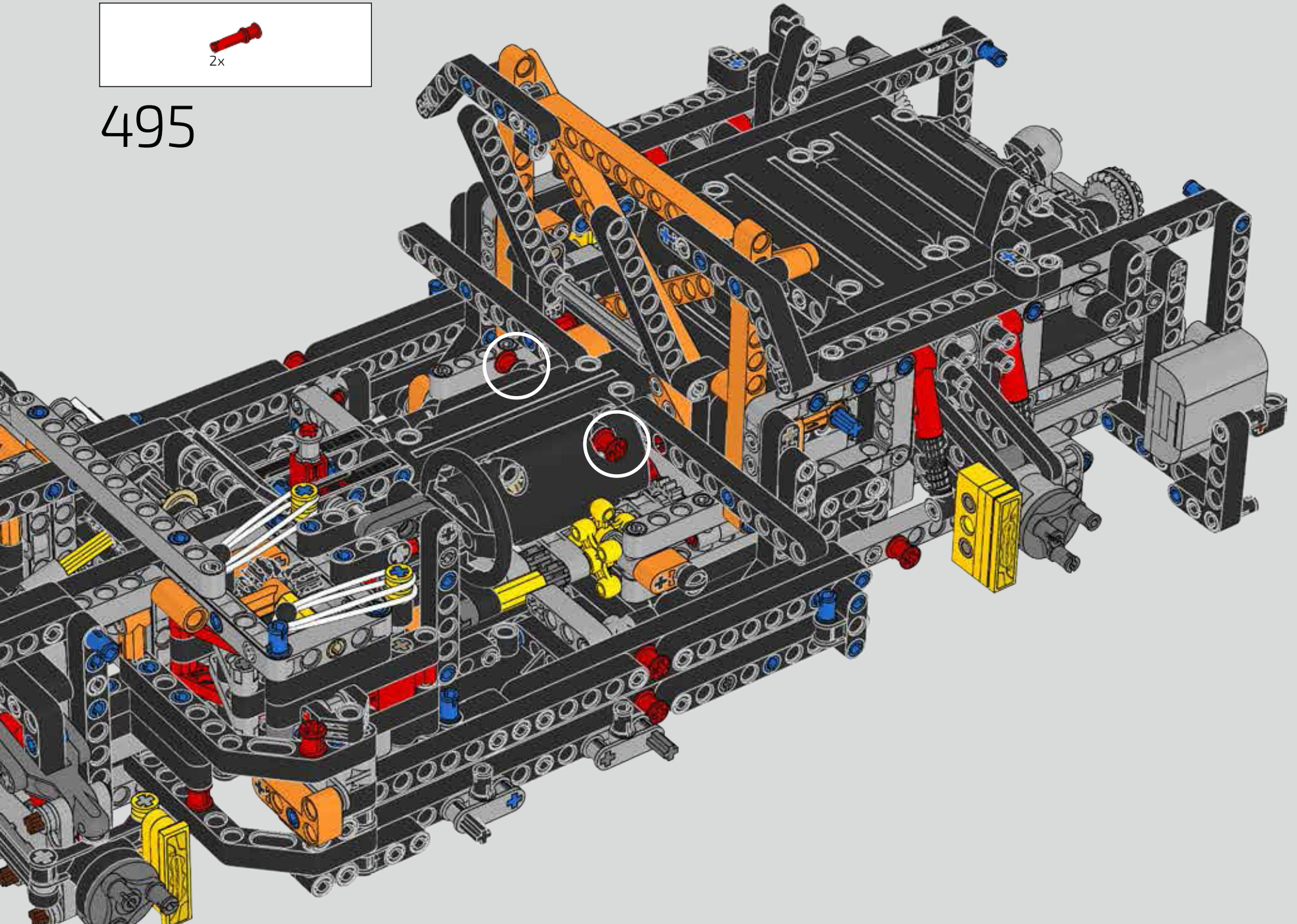

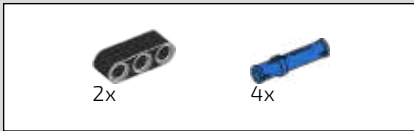

496

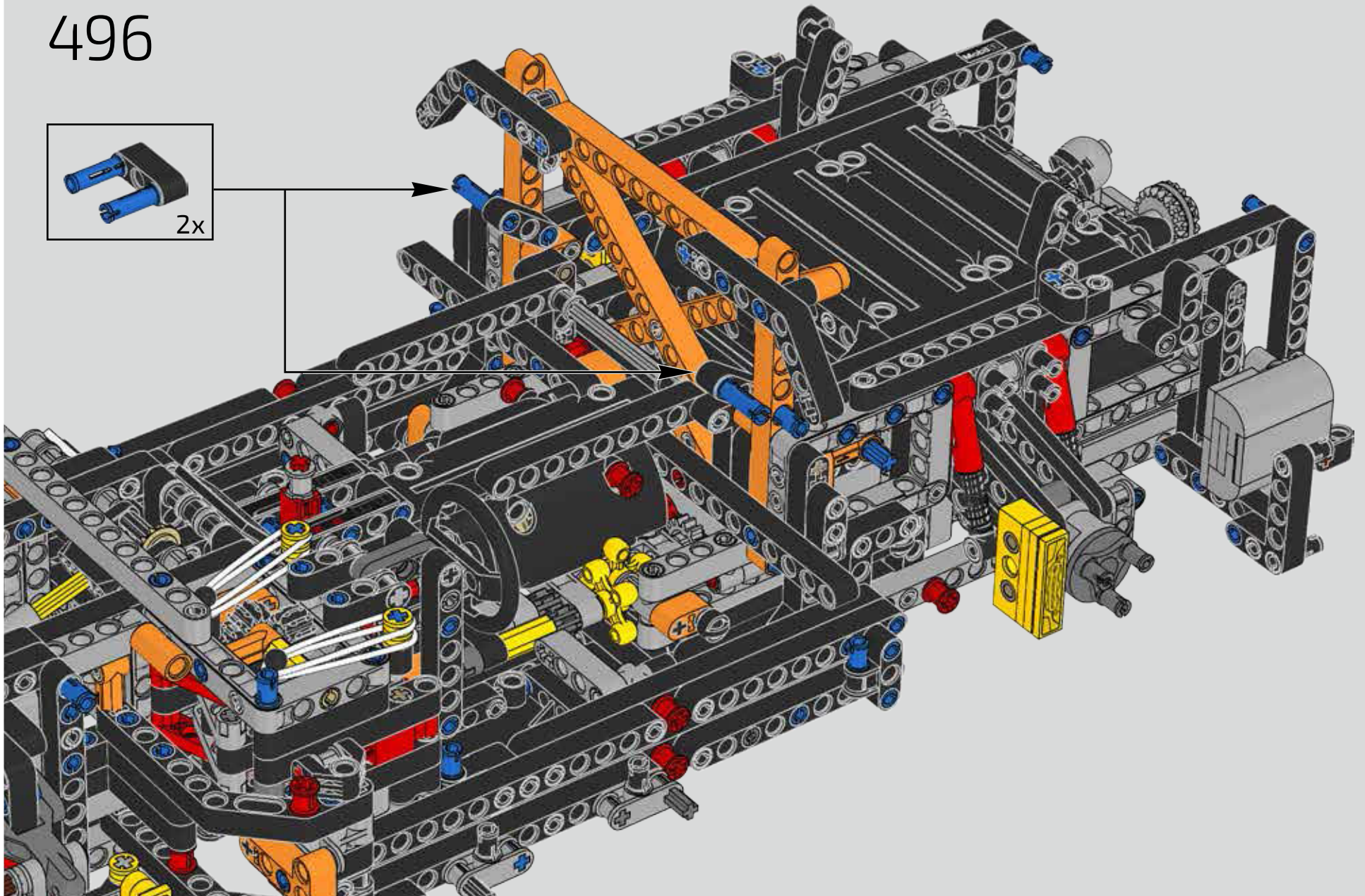
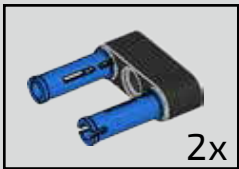

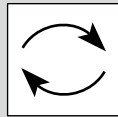
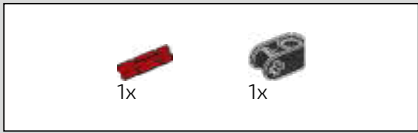

497

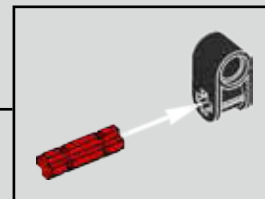
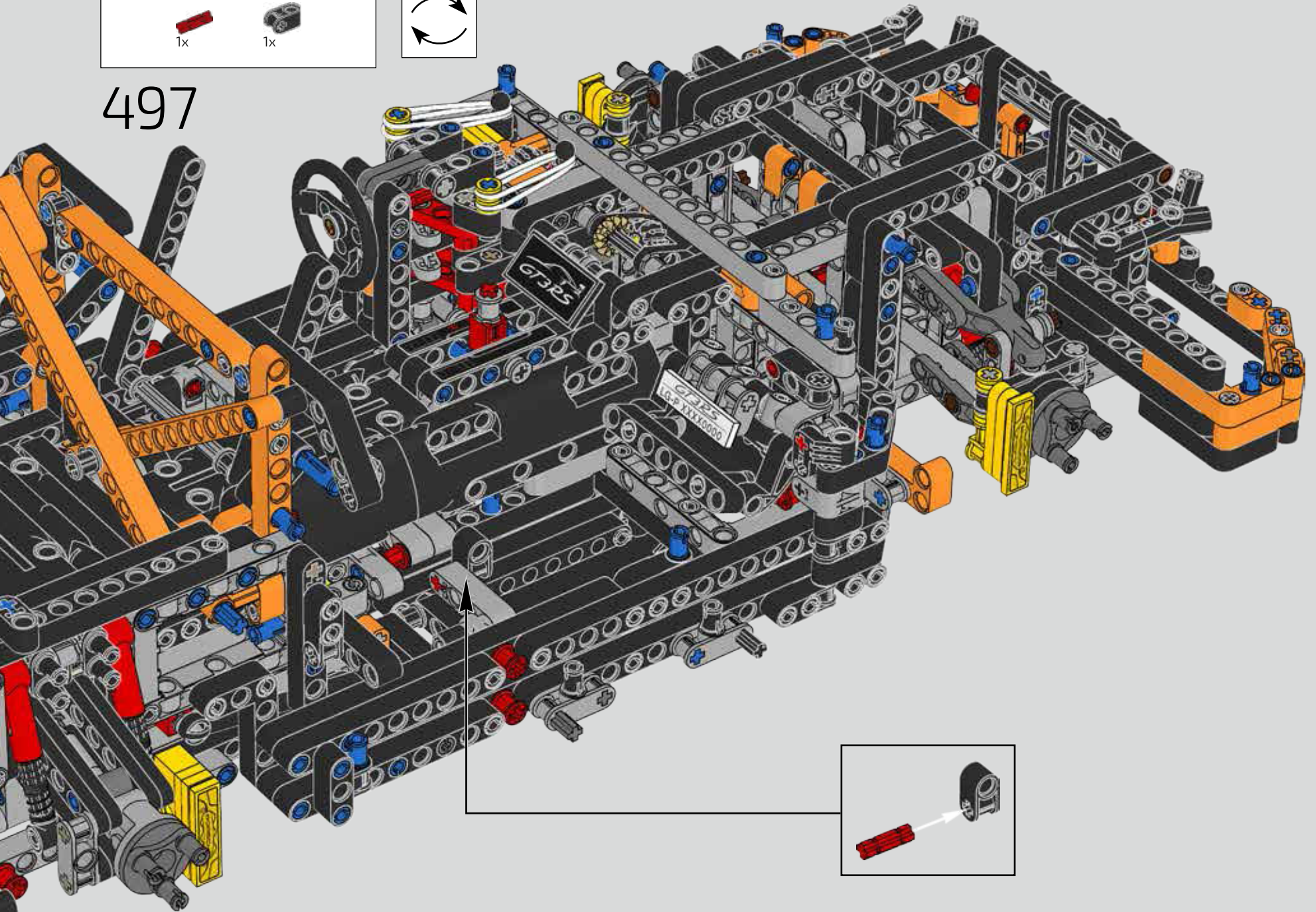

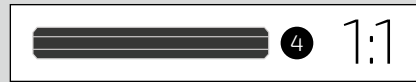
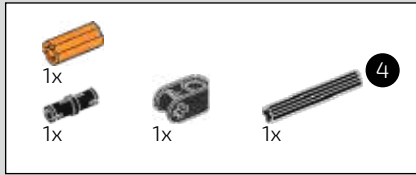

498

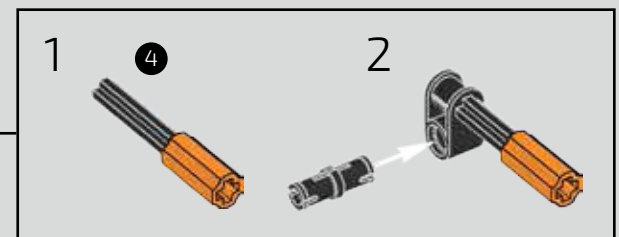
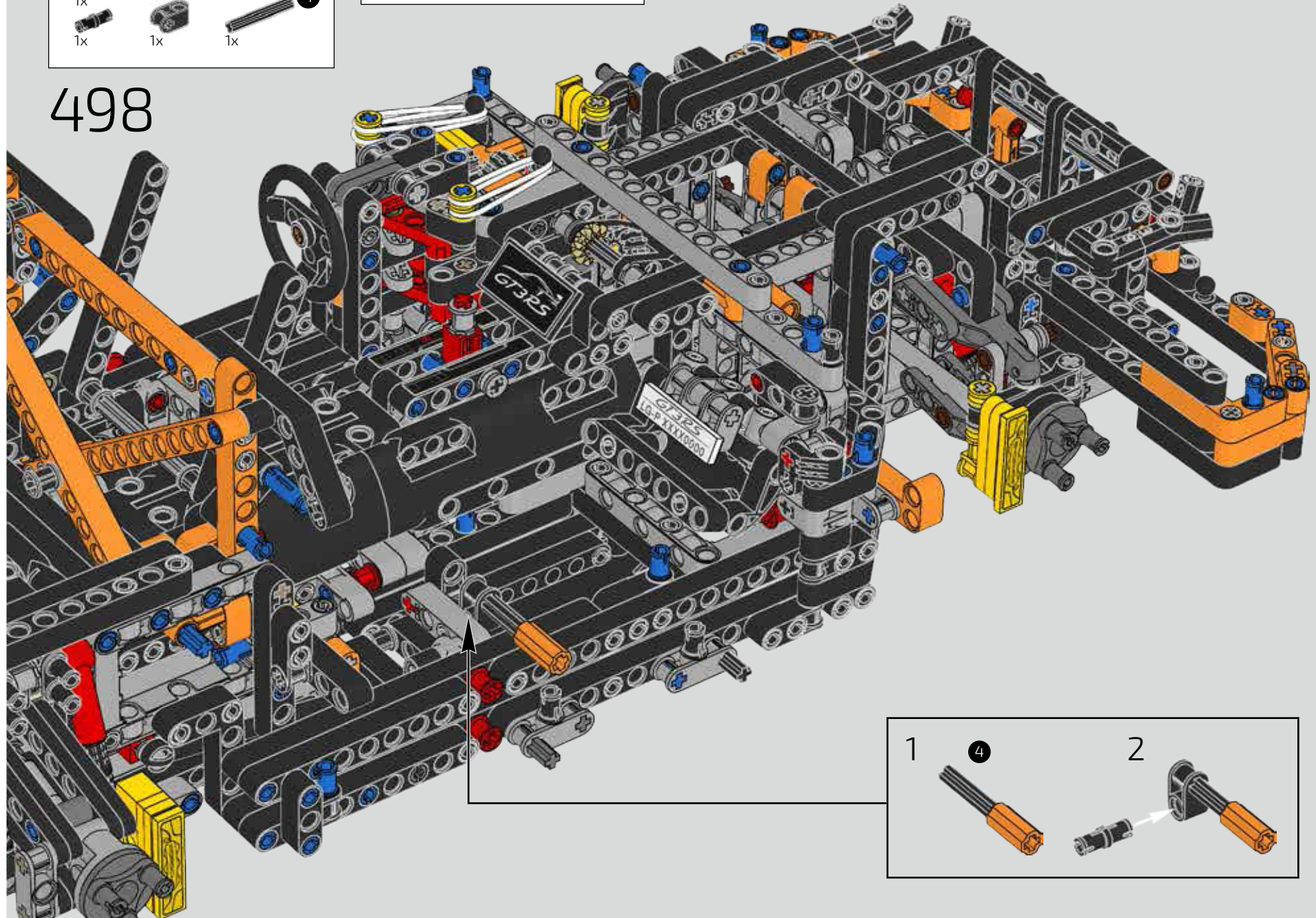

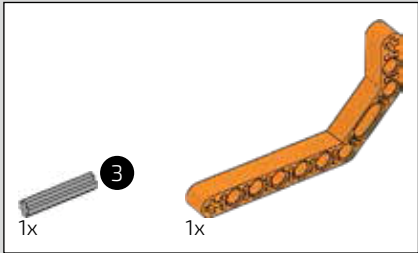

499

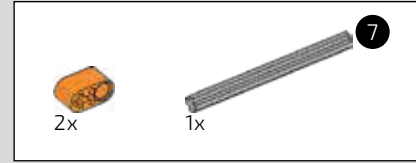

500

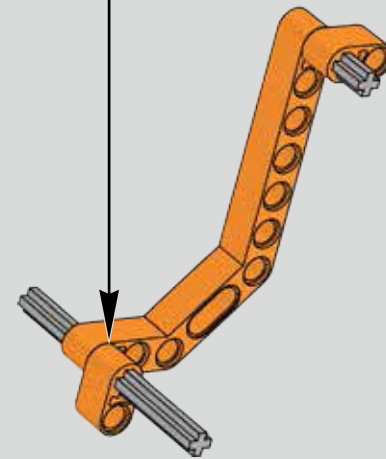
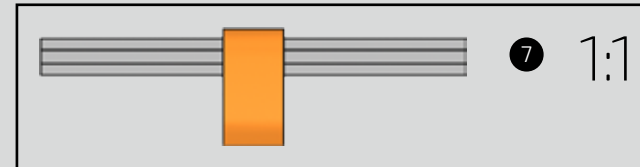

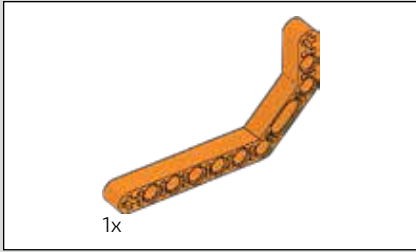

501

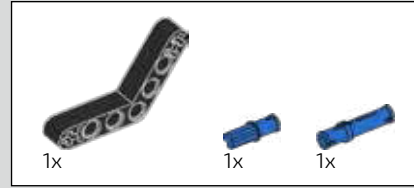
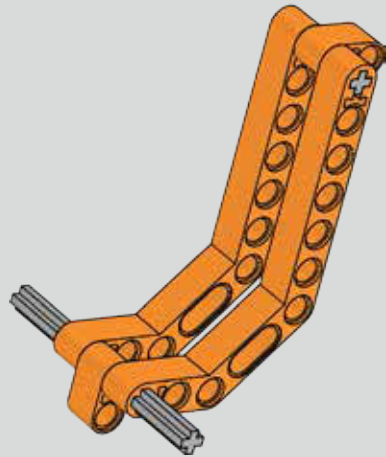

502

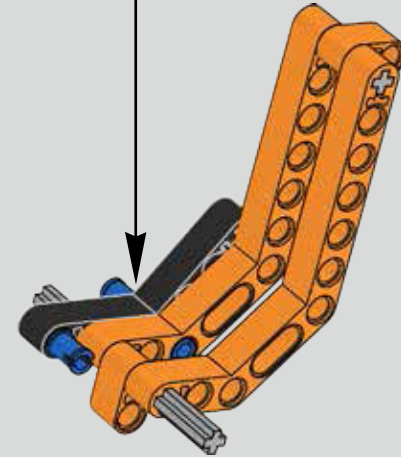
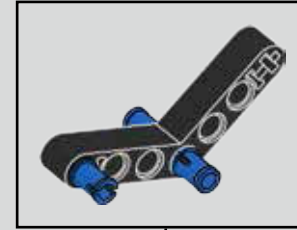

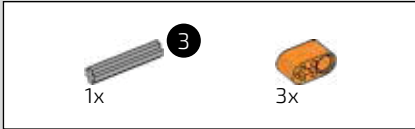

503

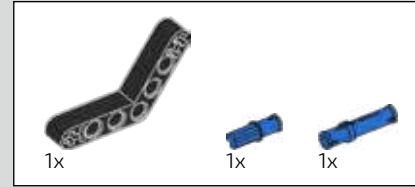
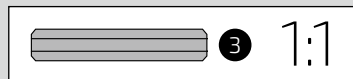
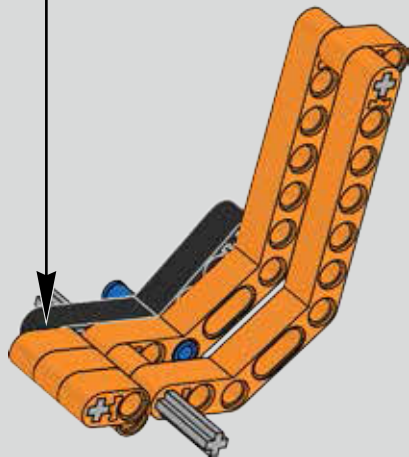

504

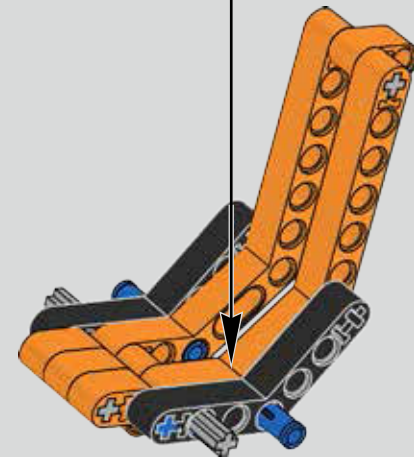
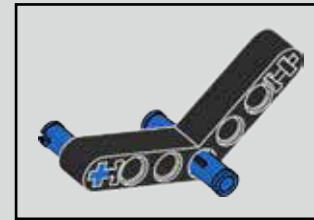

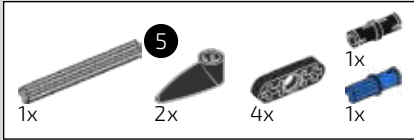

505

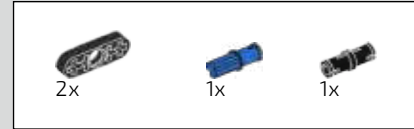
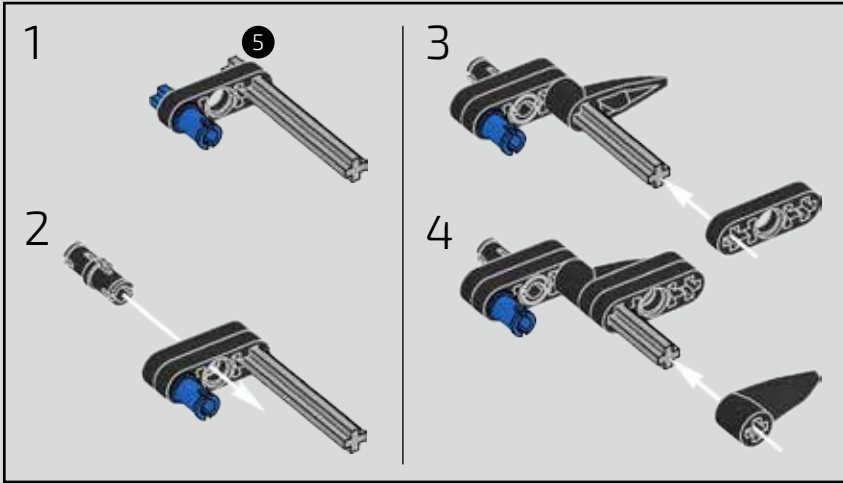

506

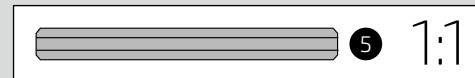
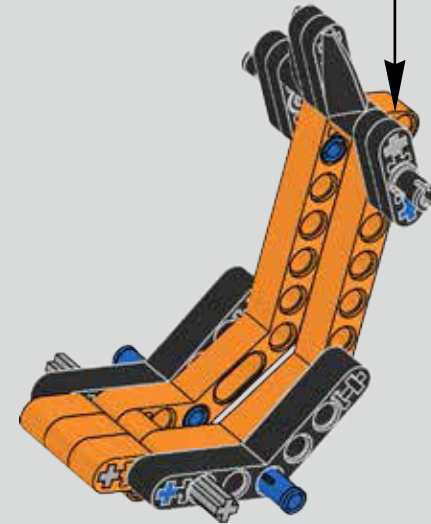
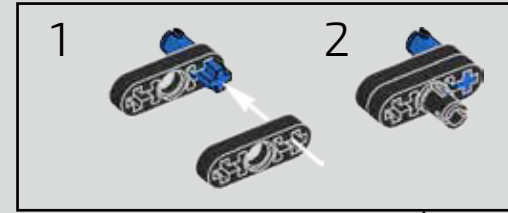

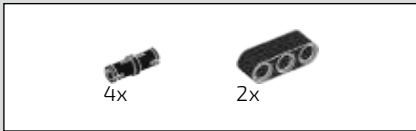

507

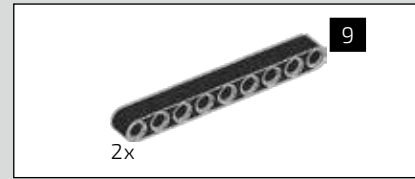
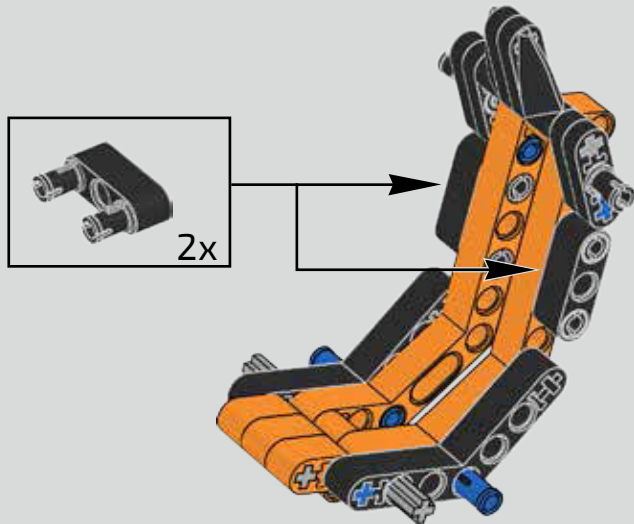

508



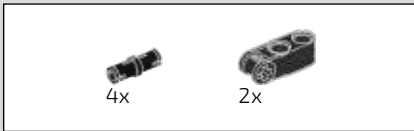

509

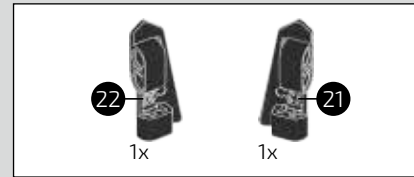
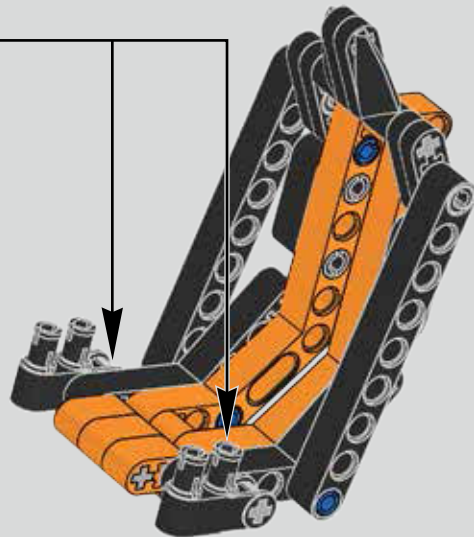
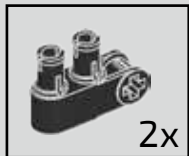

510



511

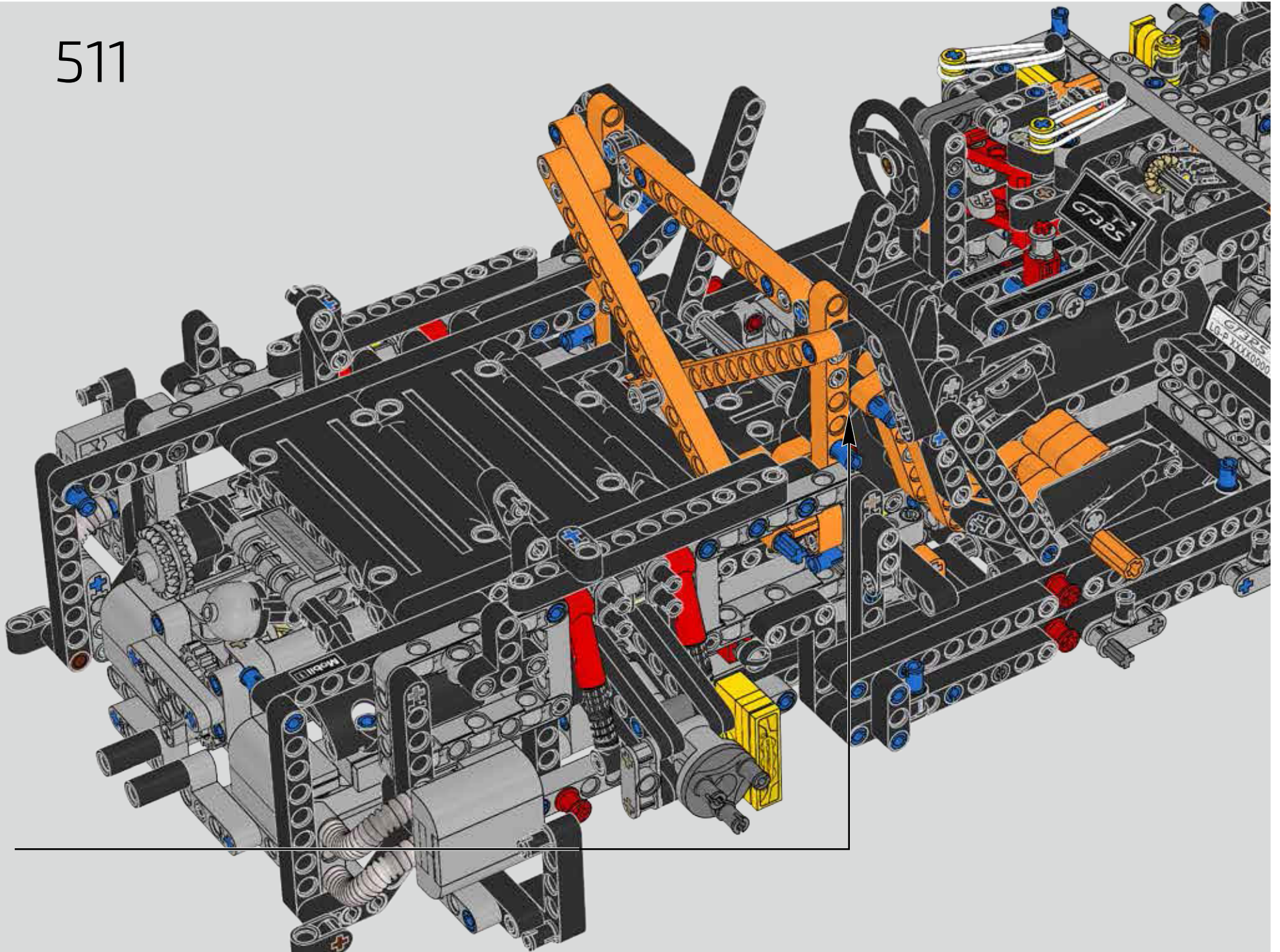



512

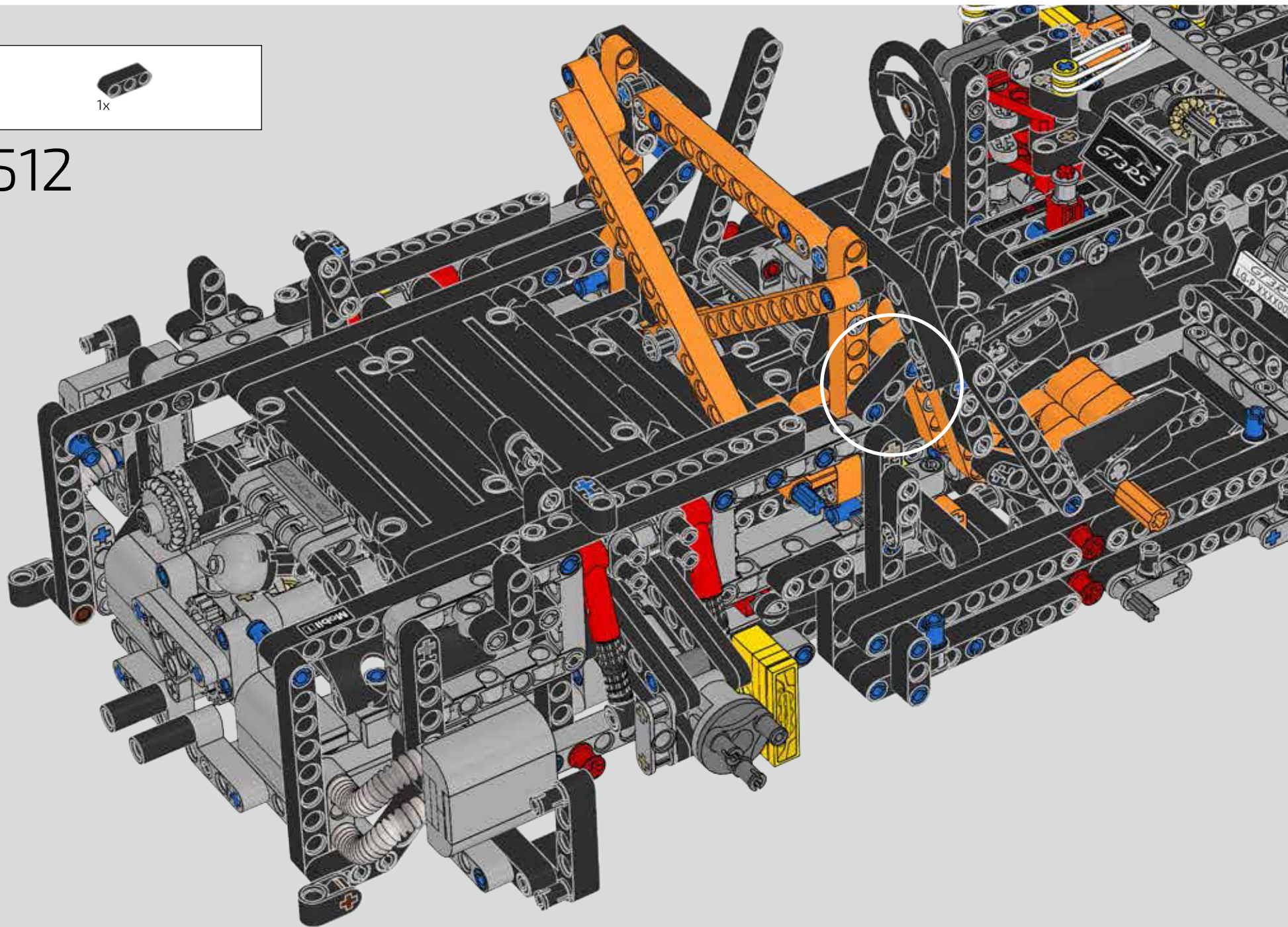

513

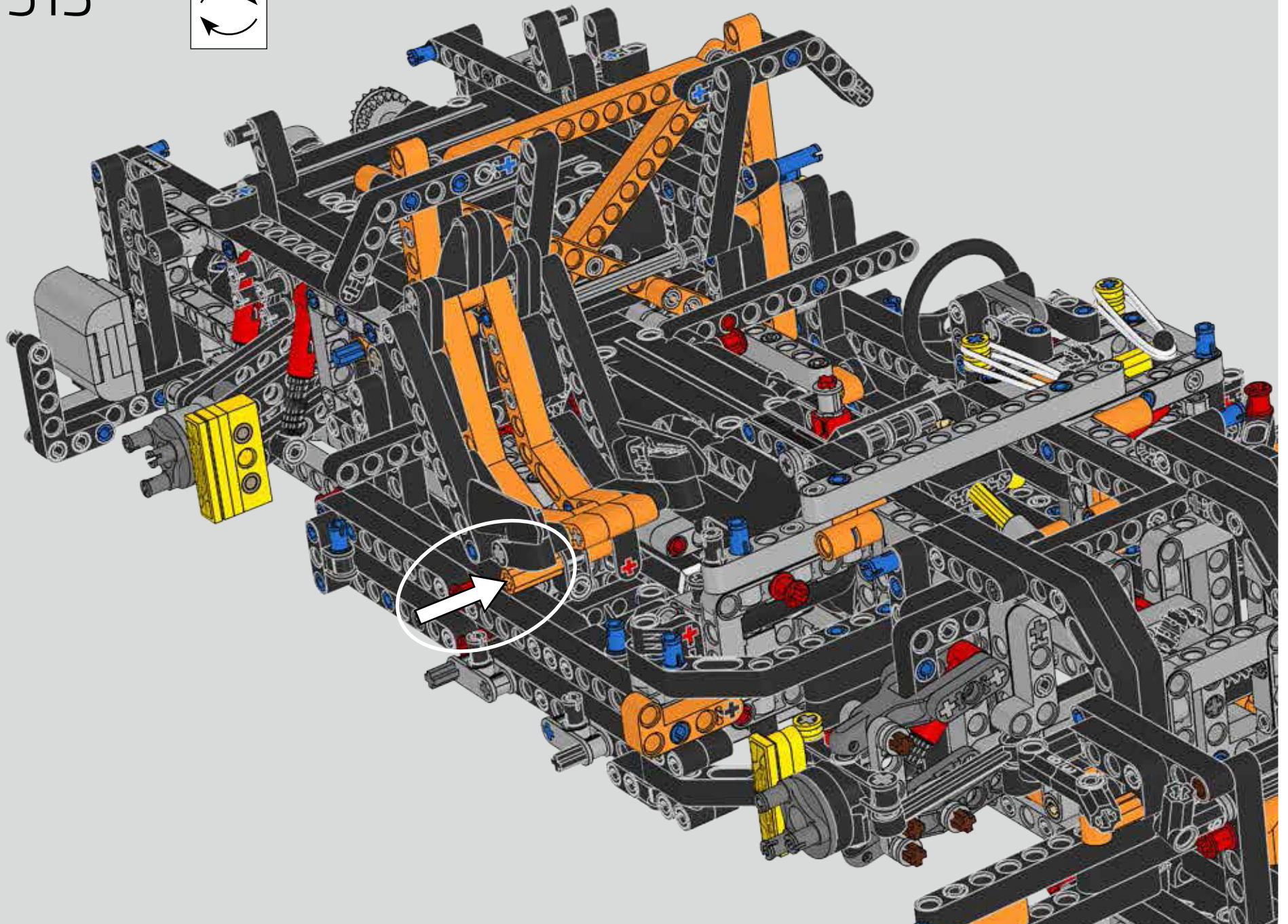
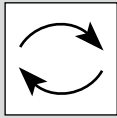

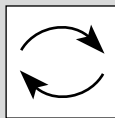

514

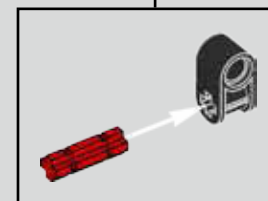
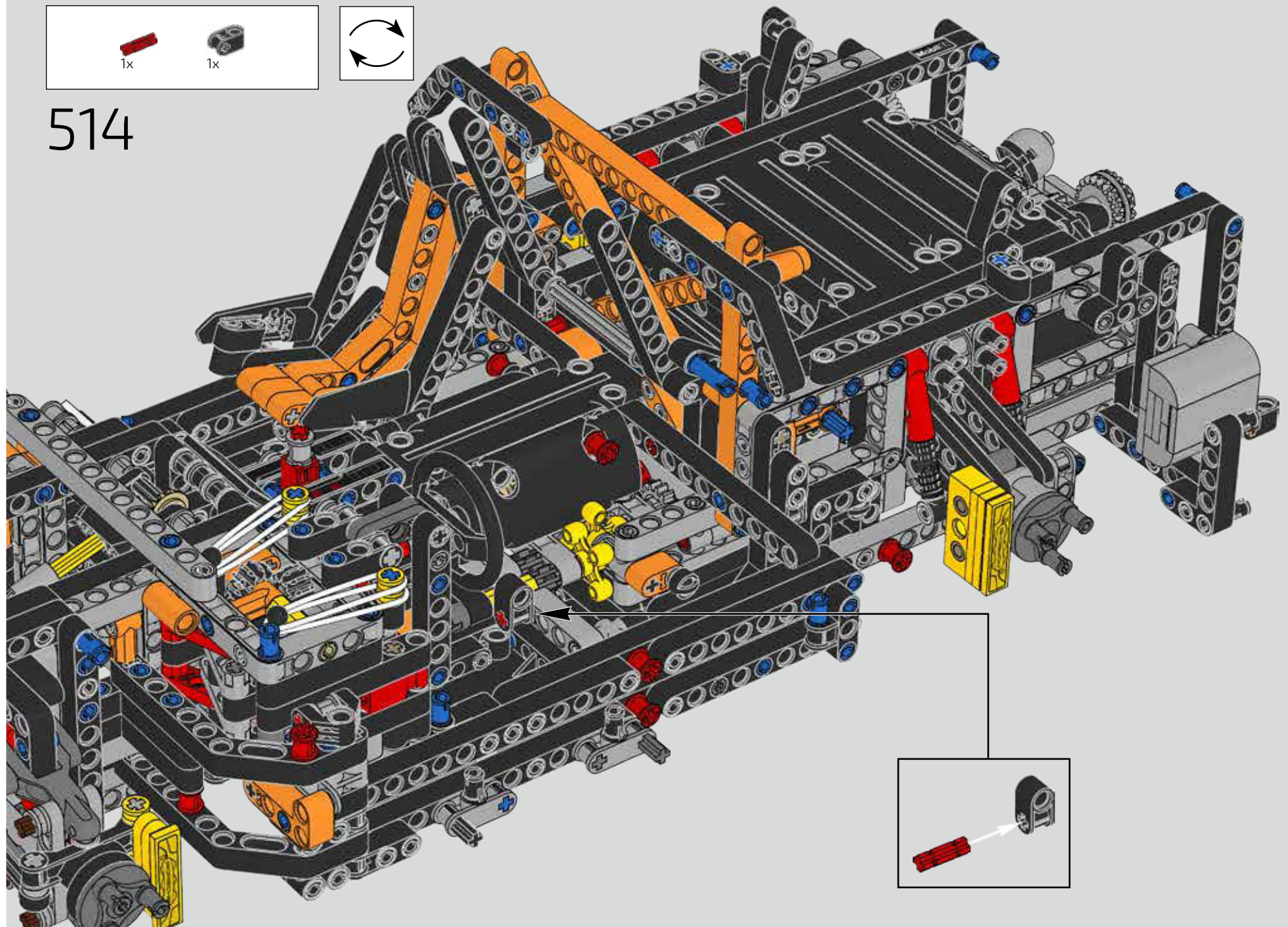

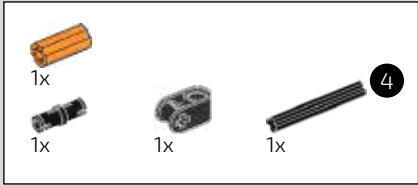

515

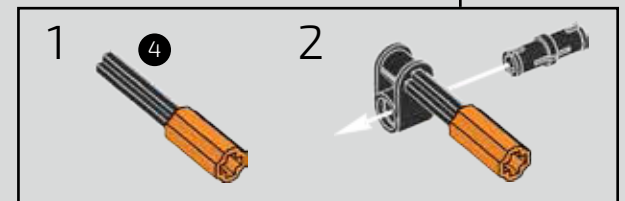
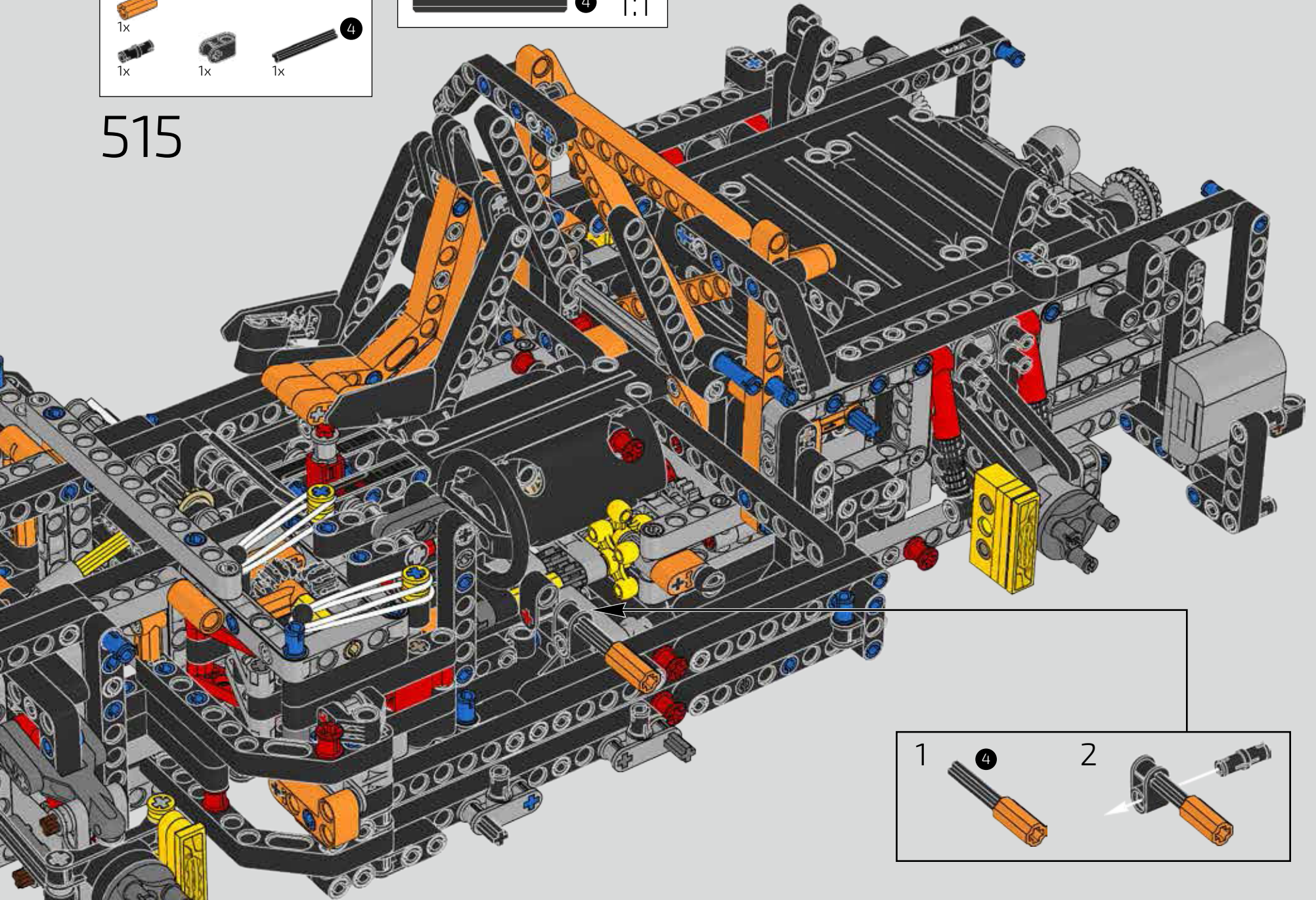

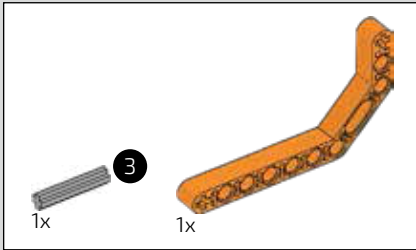

516

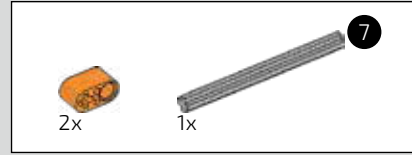
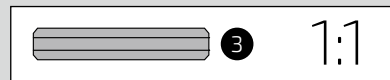

517

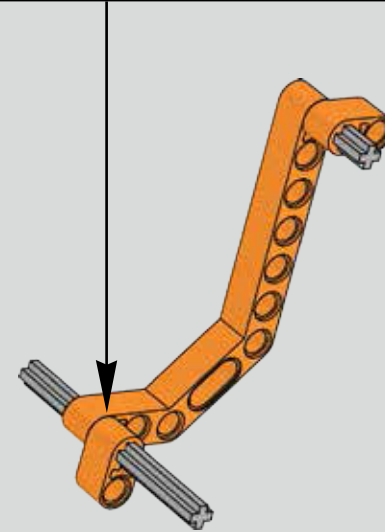
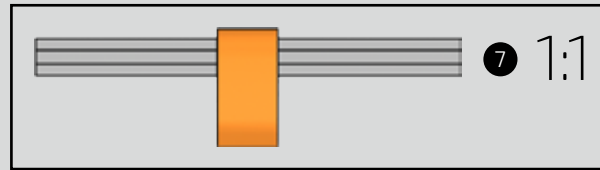

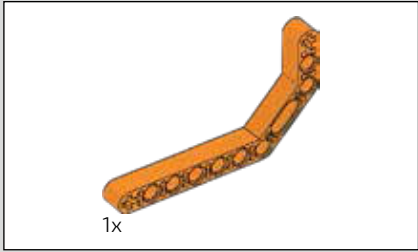

518

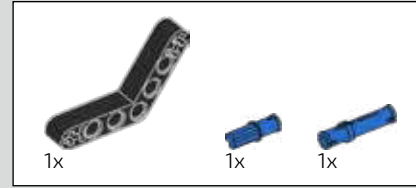
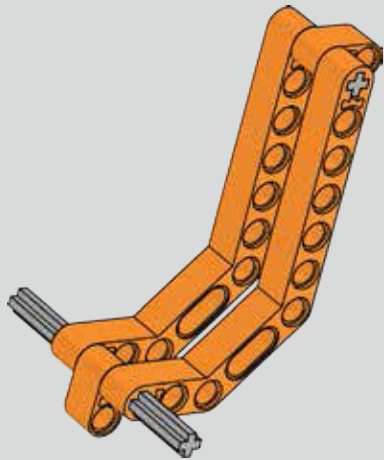

519

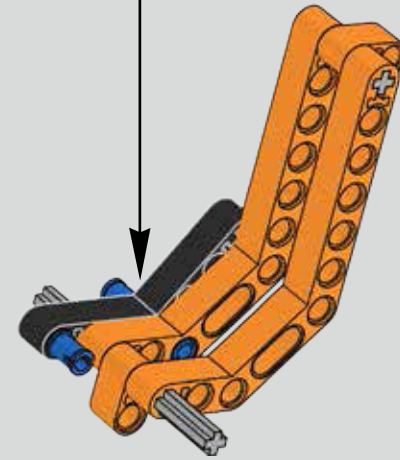
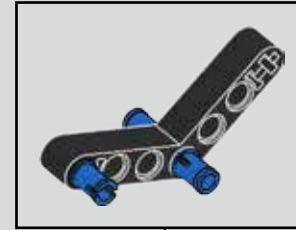

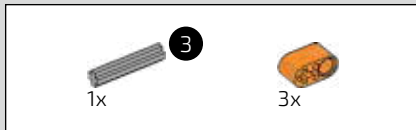

520

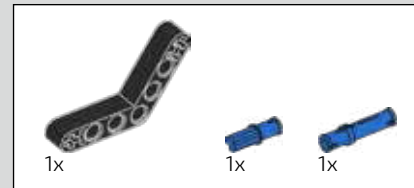
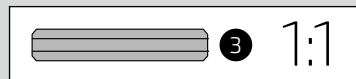
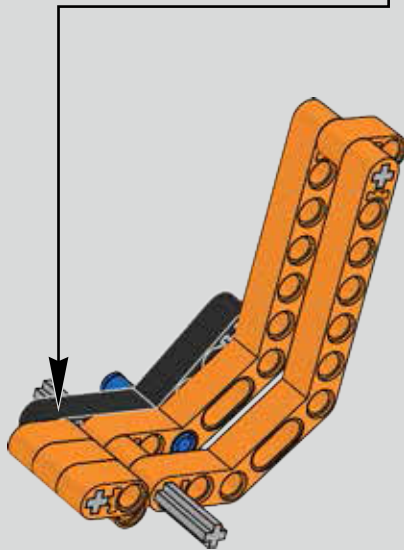

521

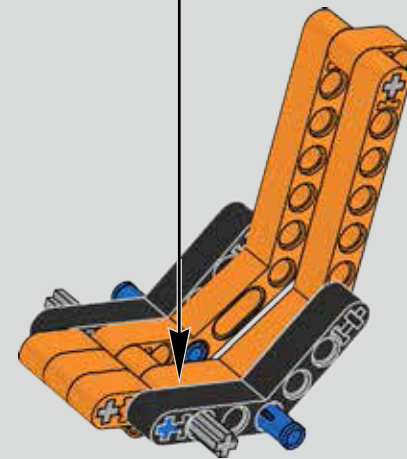
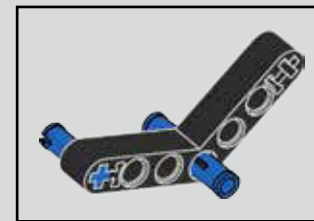

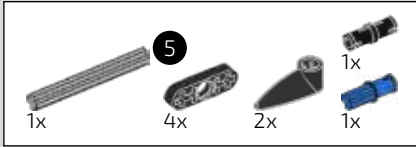

522

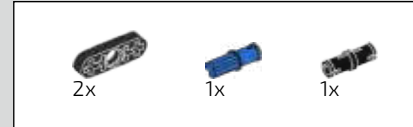
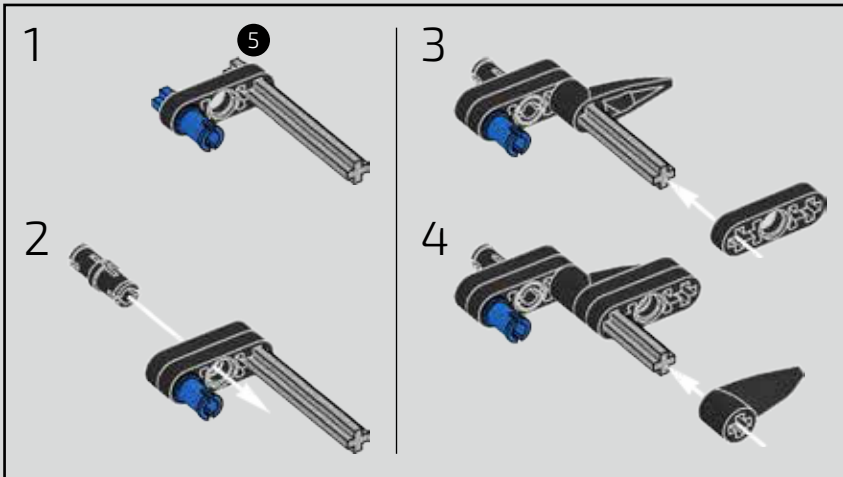

523

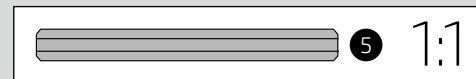
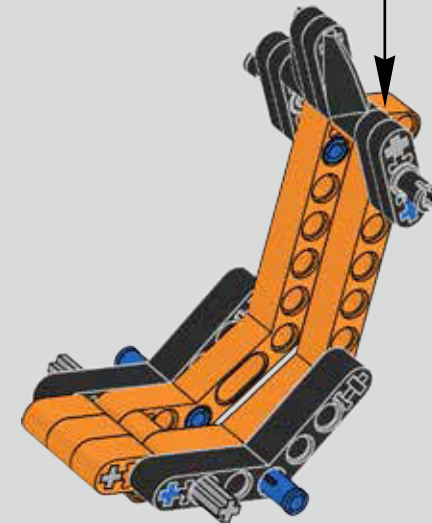
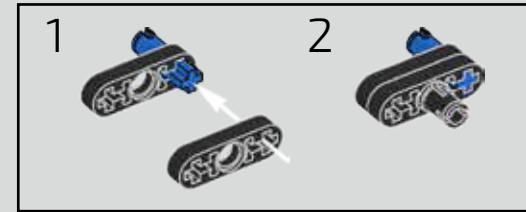

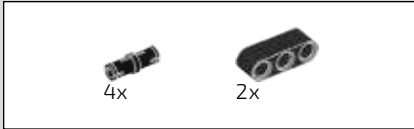

524

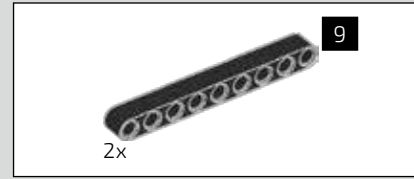
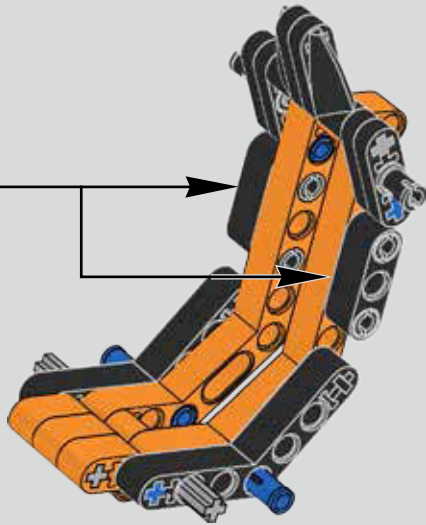
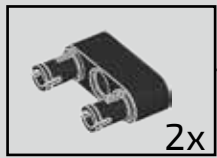

525



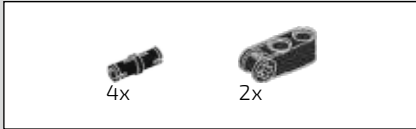

526

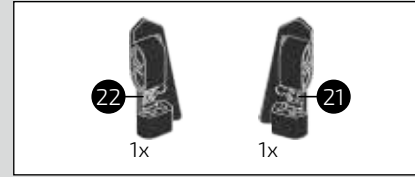
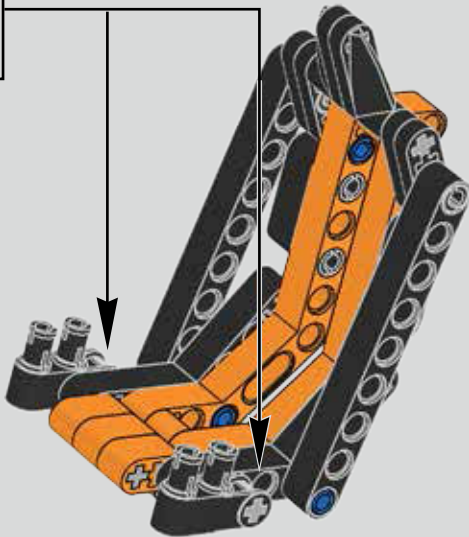
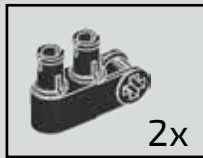

527



528

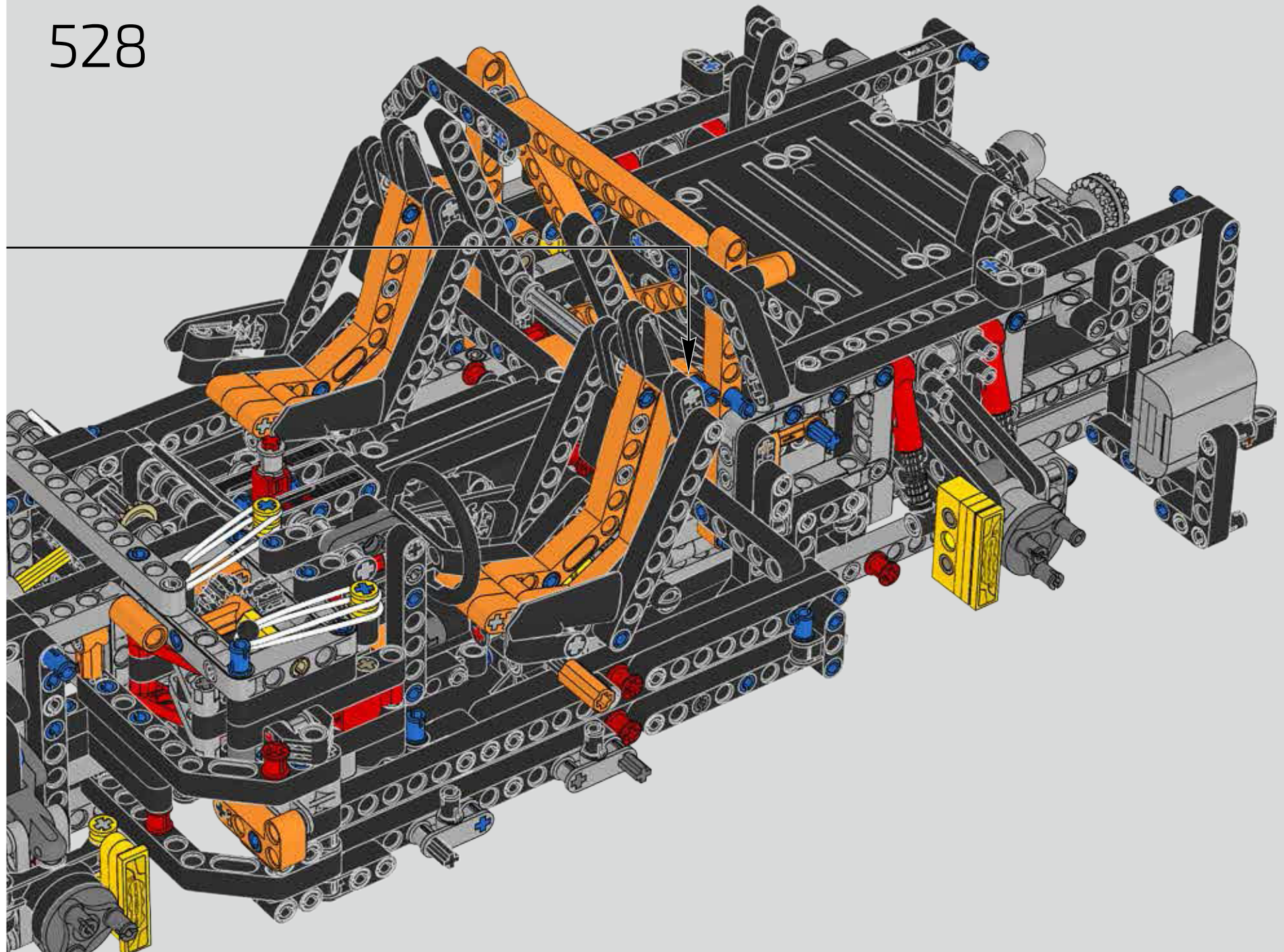



529

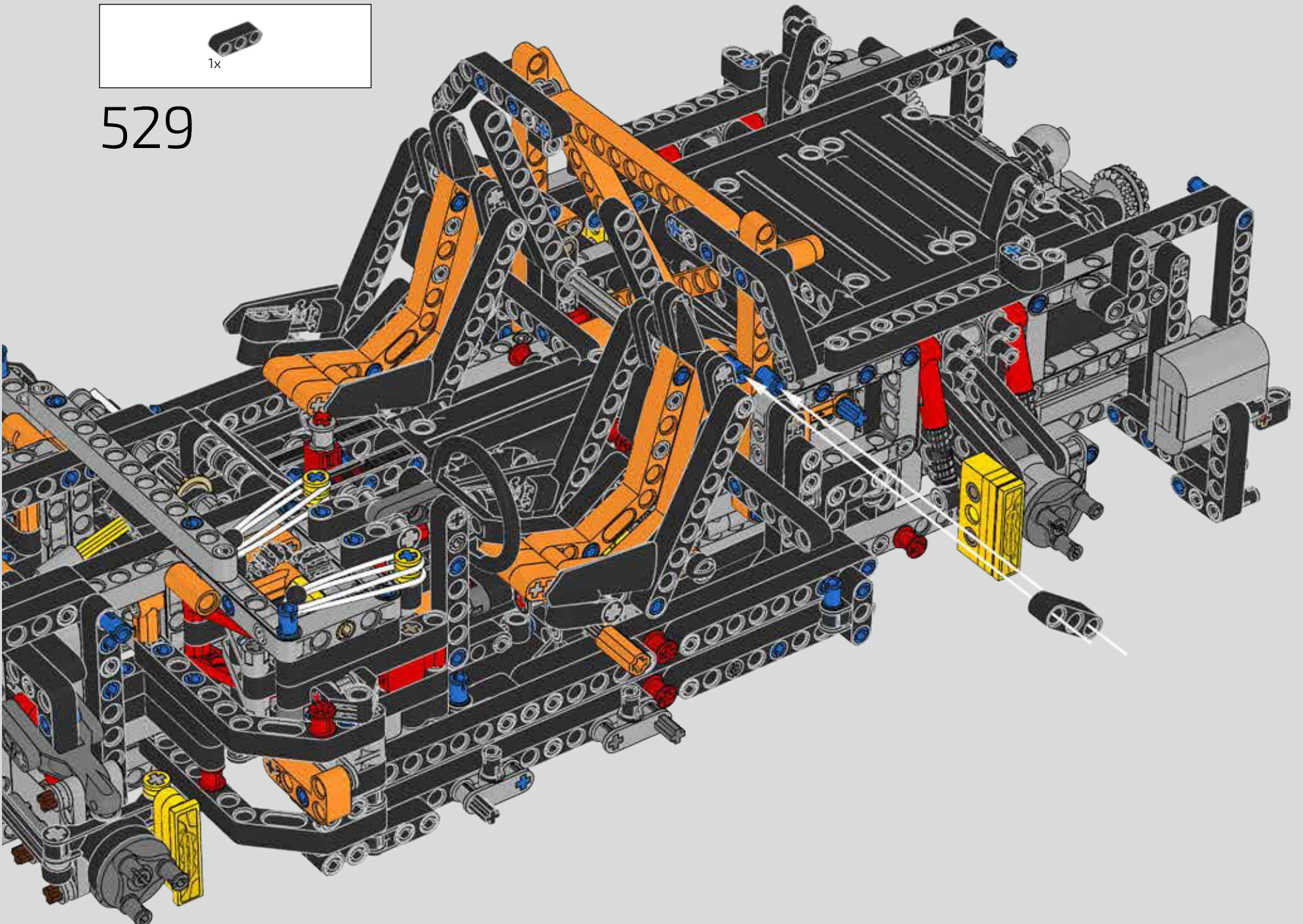

530

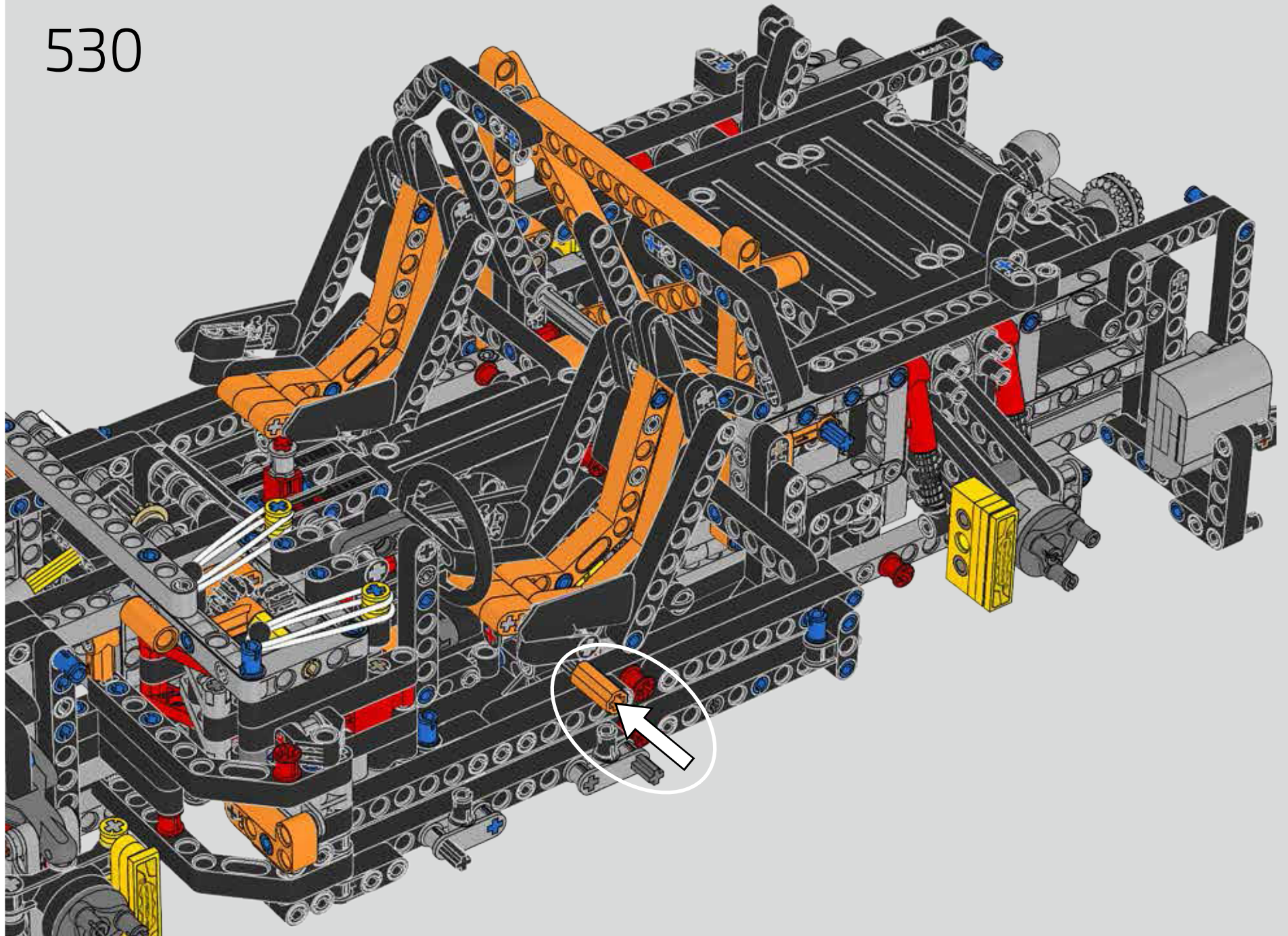

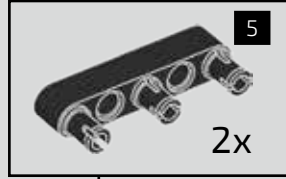
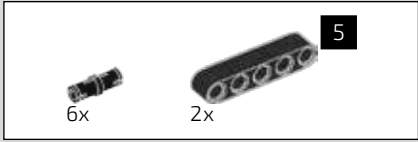

531

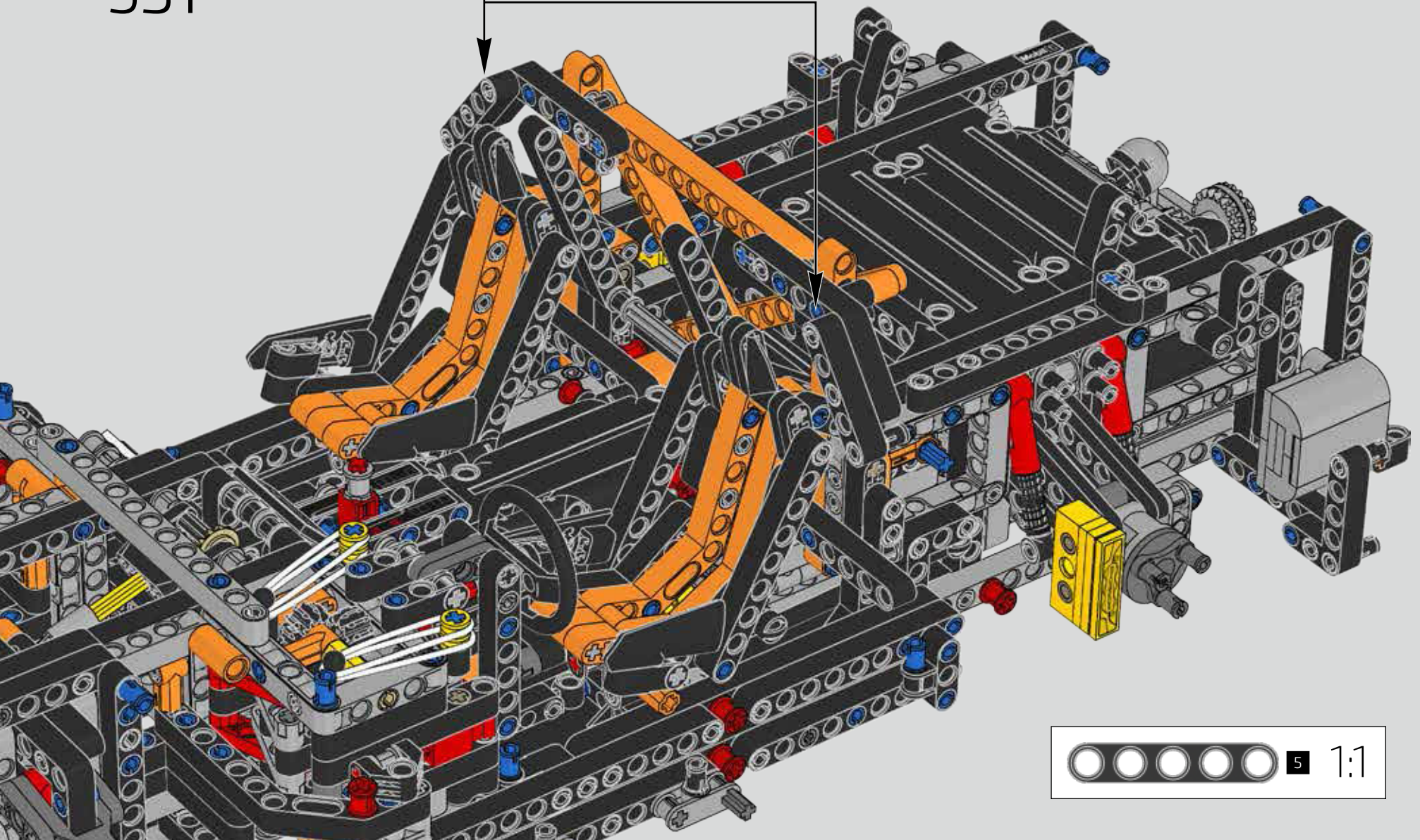



3

In box 3 you start to assemble the body of your 911 GT3 RS. Starting with the rear of the car and then onto the build of the iconic hood, now with distinctive shaping. Then it's the roof, again with distinctive shaping indicating the lightweight magnesium design only found on the newest 911 GT3 RS.

Dans la boîte 3, vous commencez à assembler la carrosserie de la 911 GT3 RS. En commençant avec l'arrière de la voiture, puis en construisant le célèbre capot, maintenant avec une forme caractéristique. Puis c'est ensuite le toit, également doté d'une forme distinctive reproduisant le design en magnésium léger présent uniquement sur la nouvelle 911 GT3 RS.



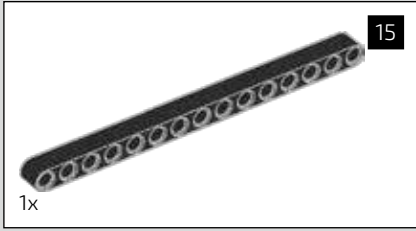

532

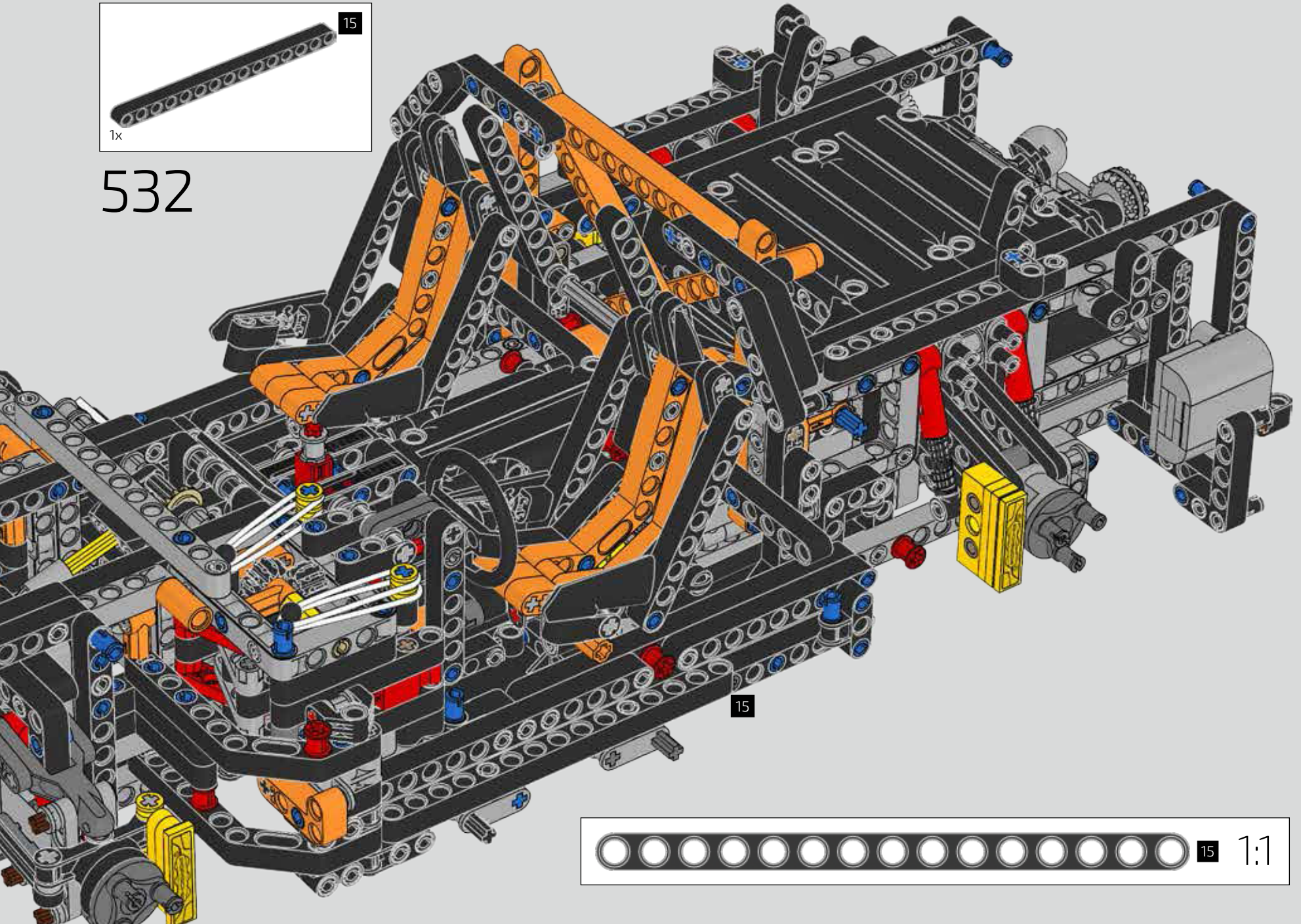

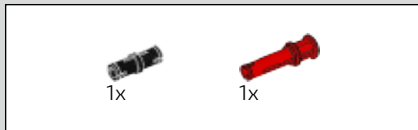

533

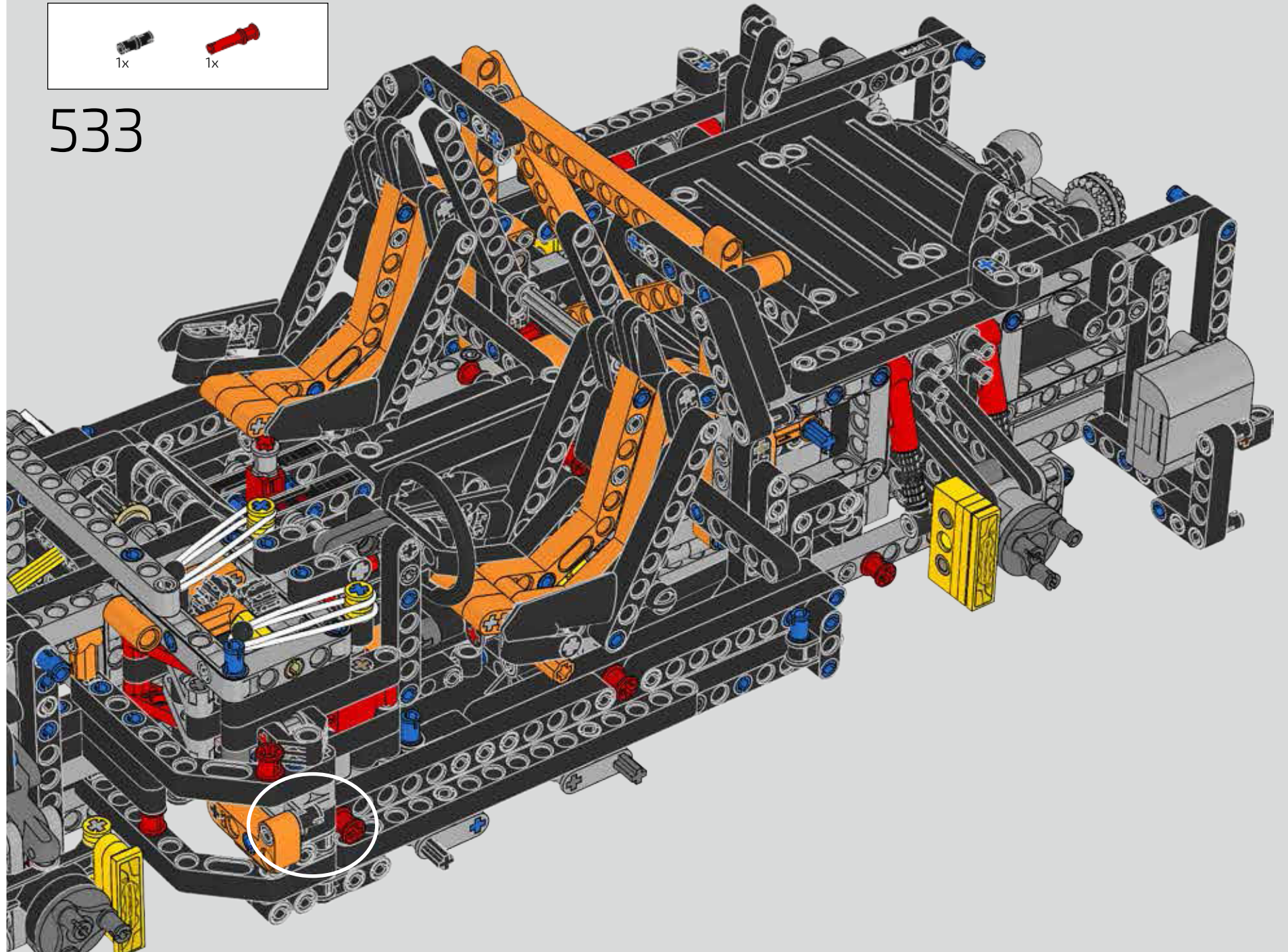

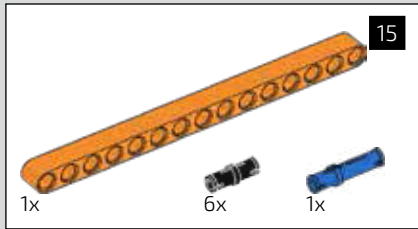
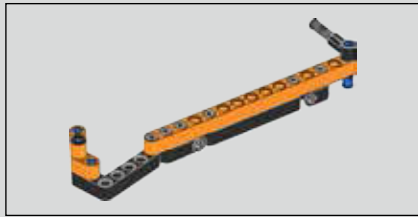

534

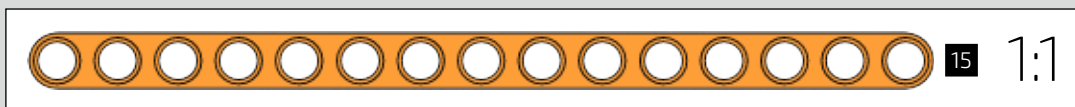
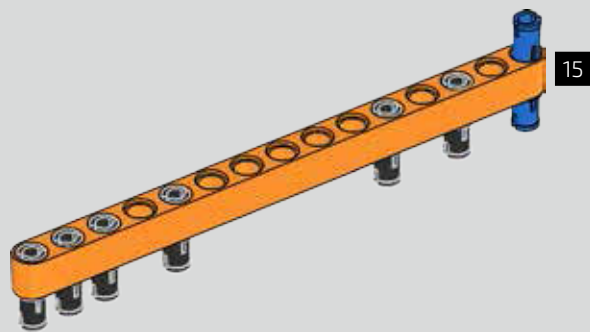

535

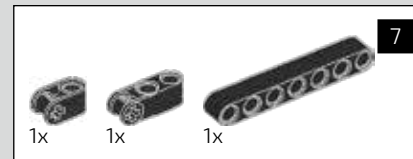
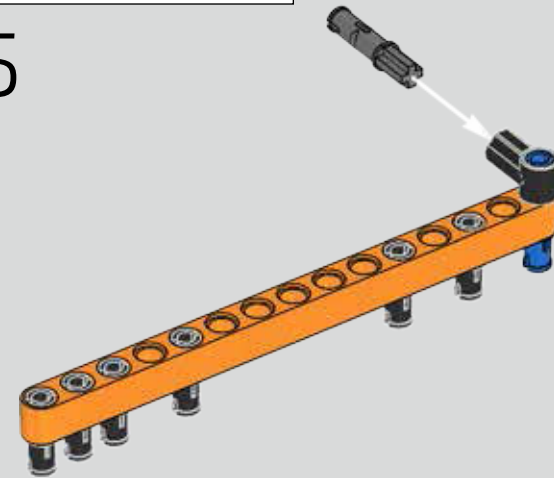

536

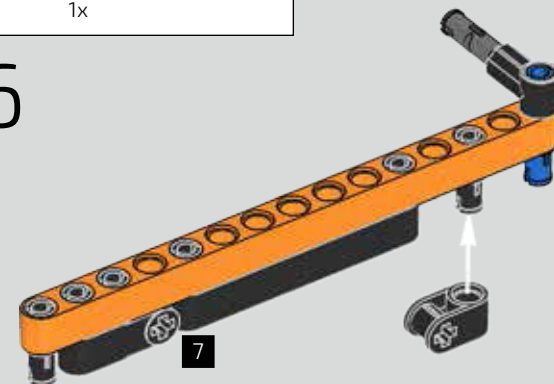

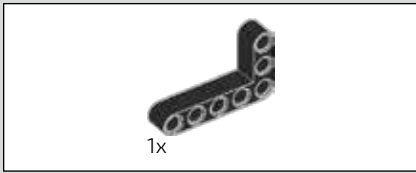

537

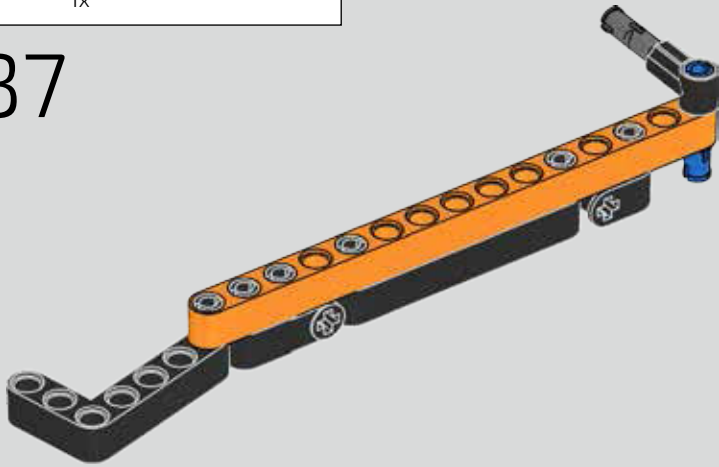

538

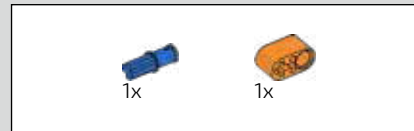
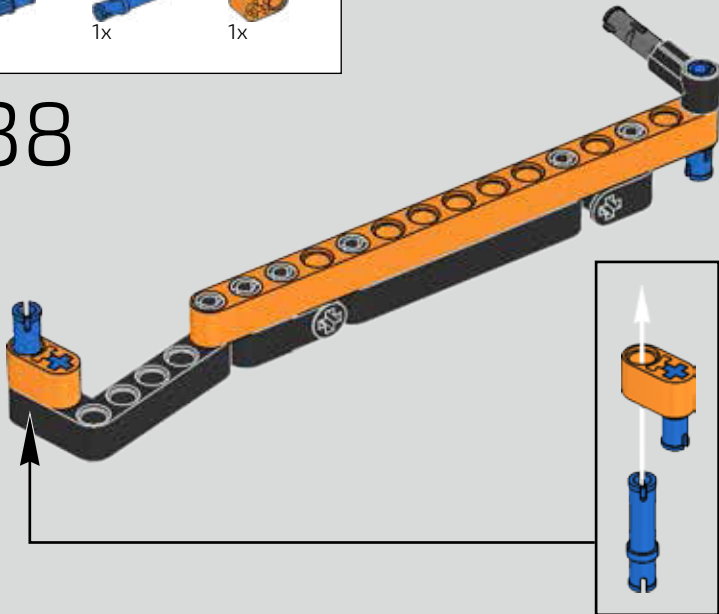

539

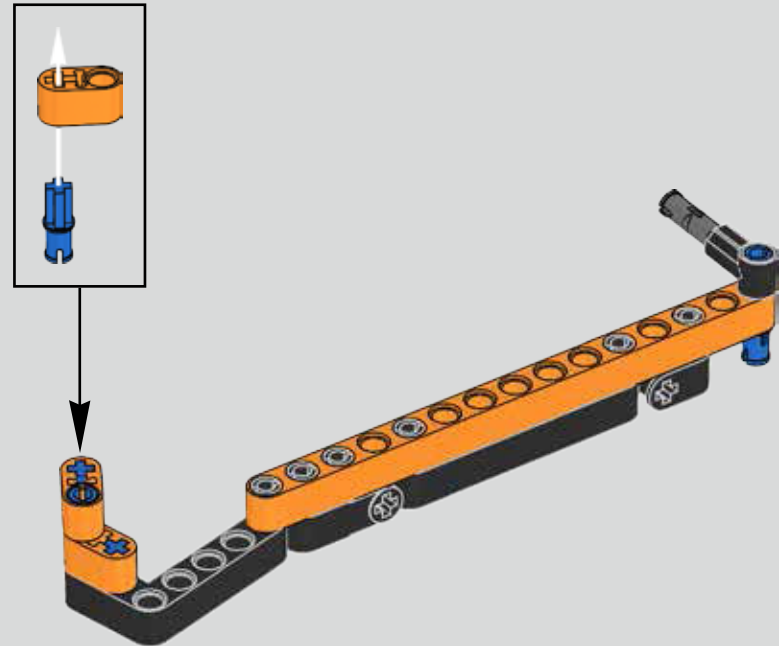

540

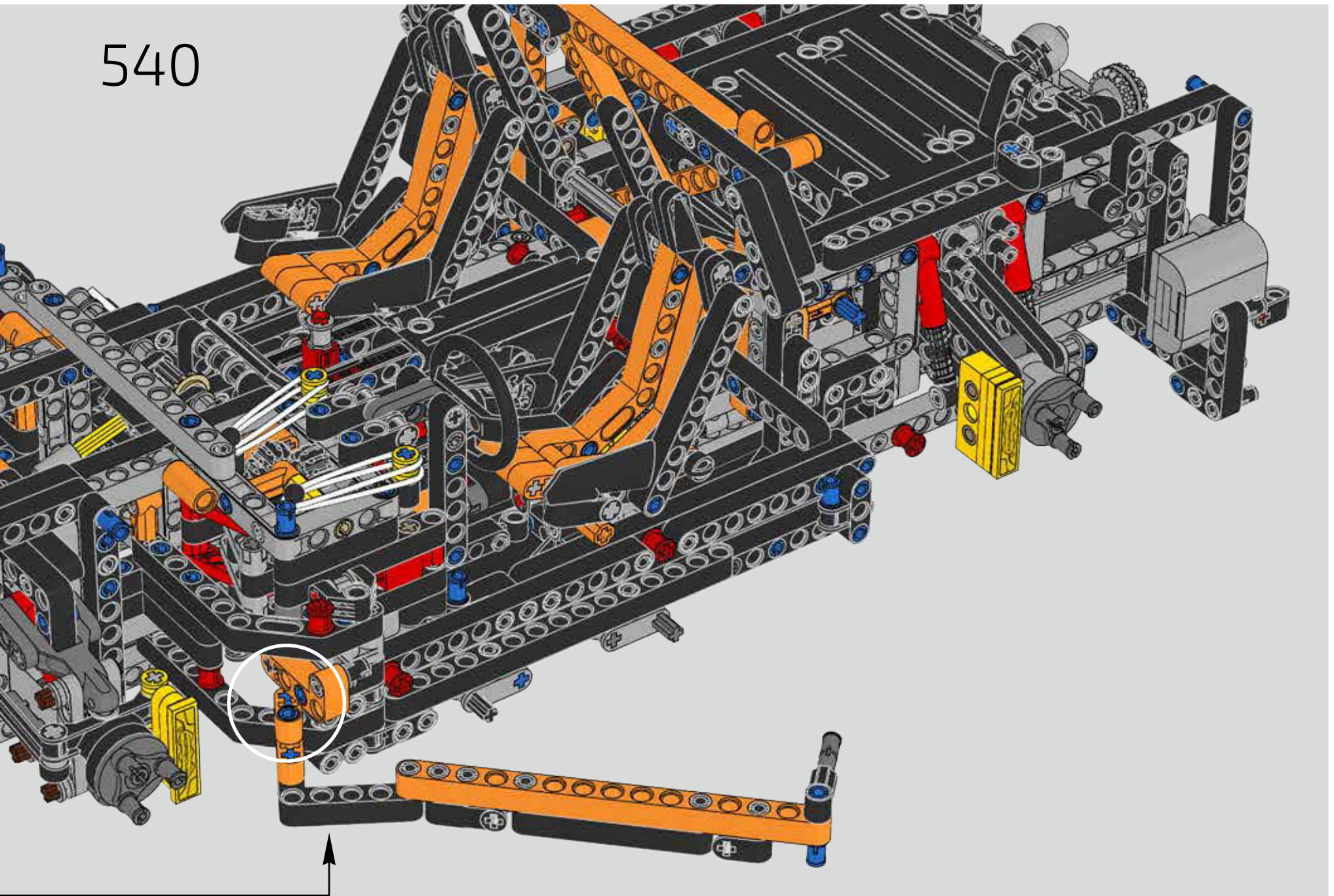

541

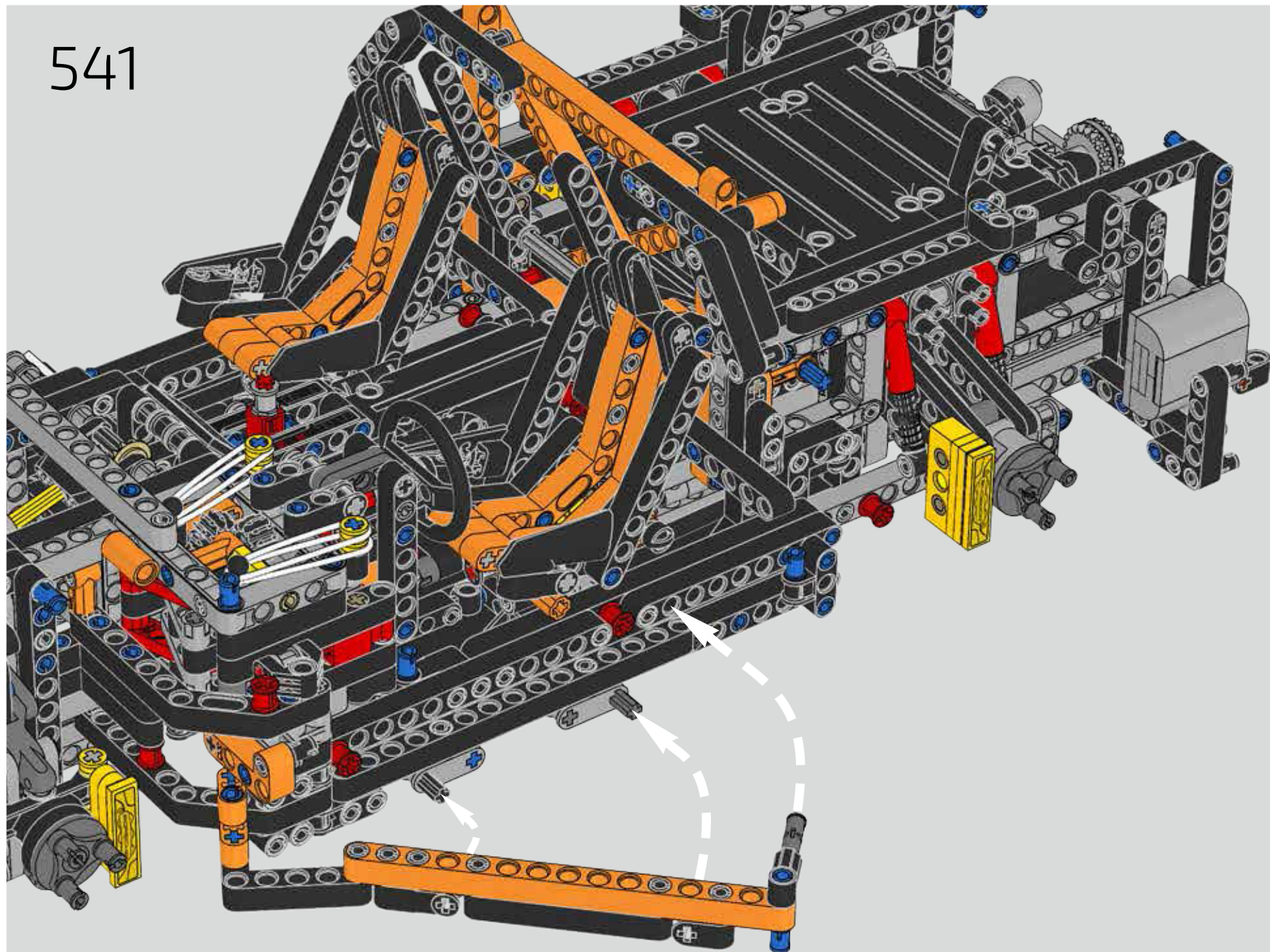

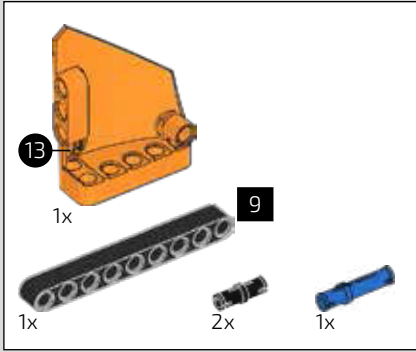

542

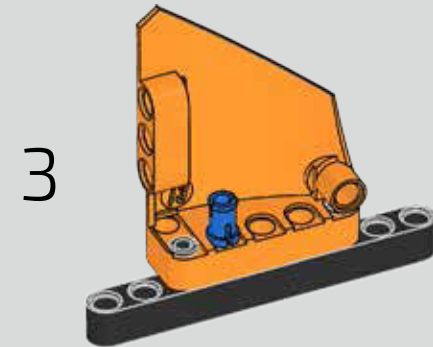
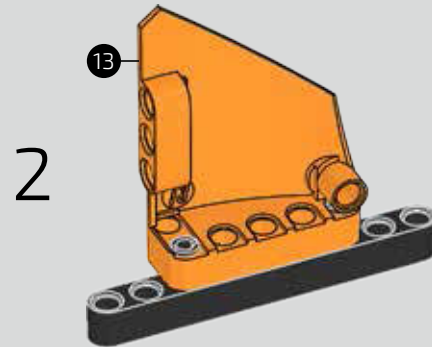
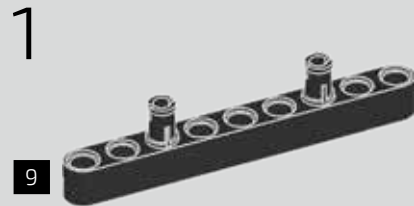

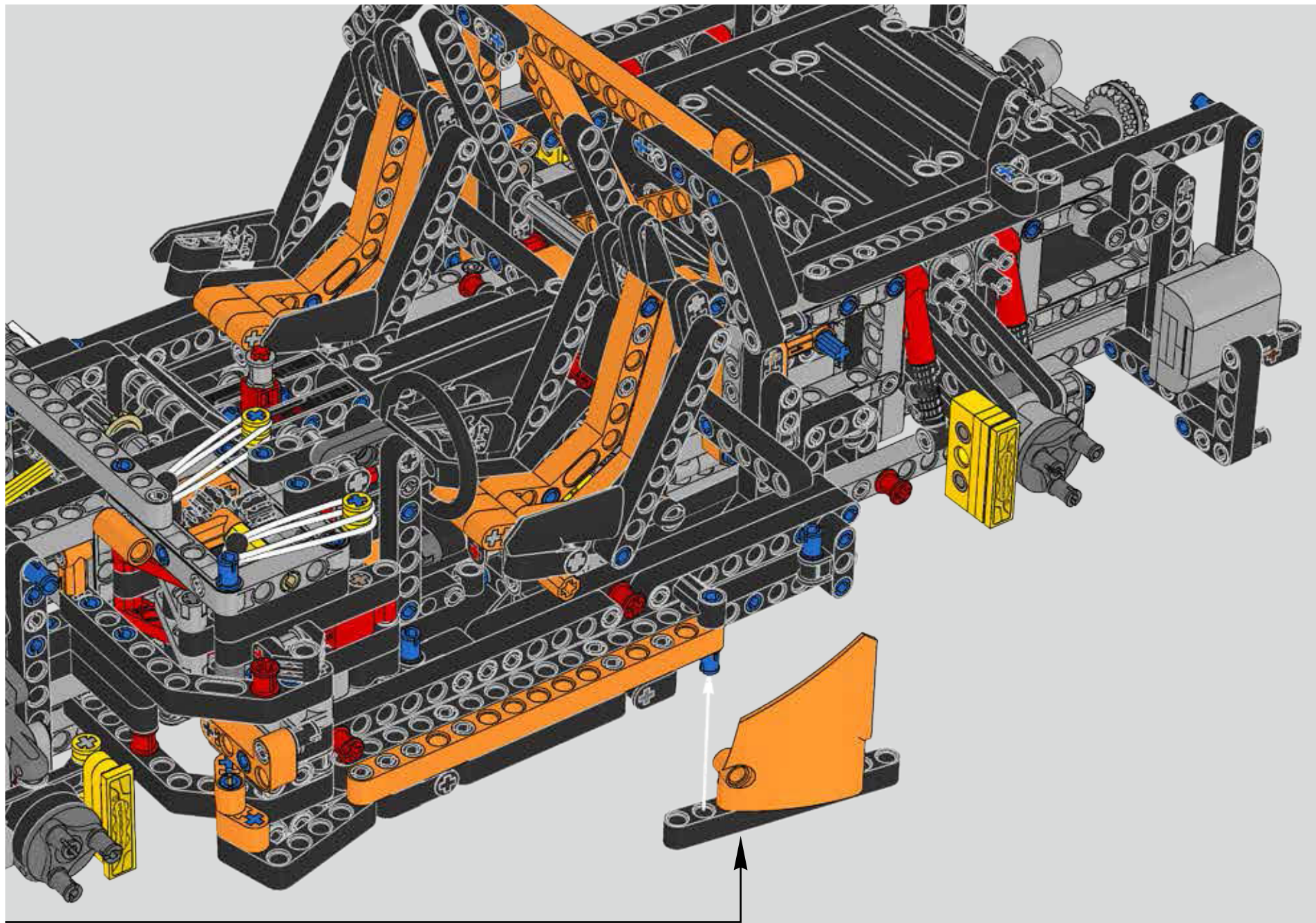

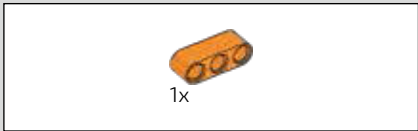

543

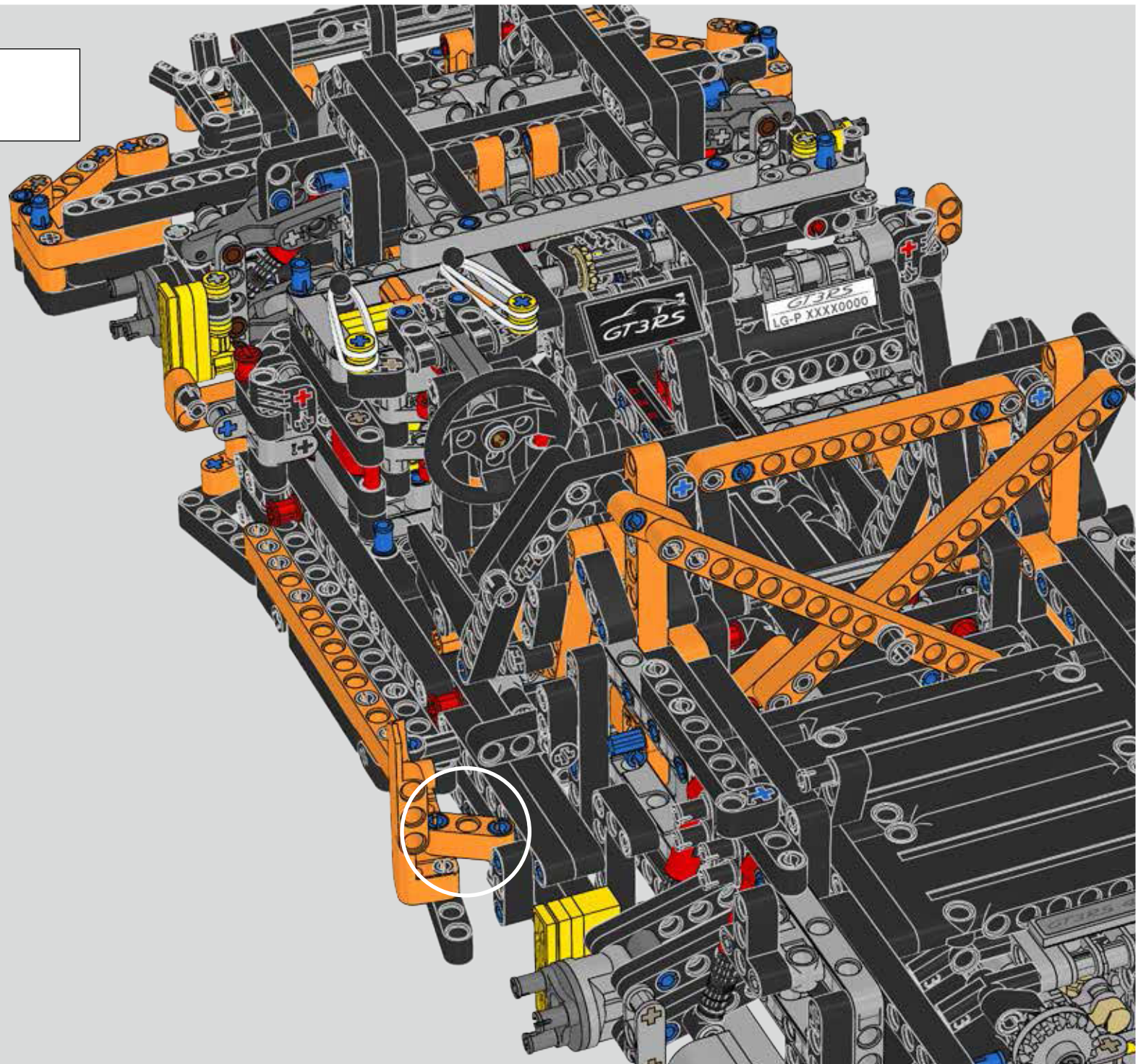
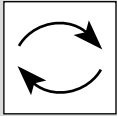



544

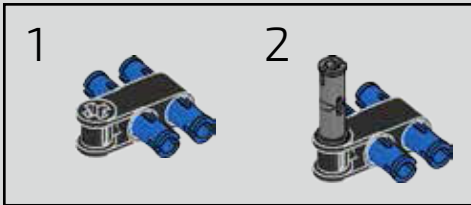
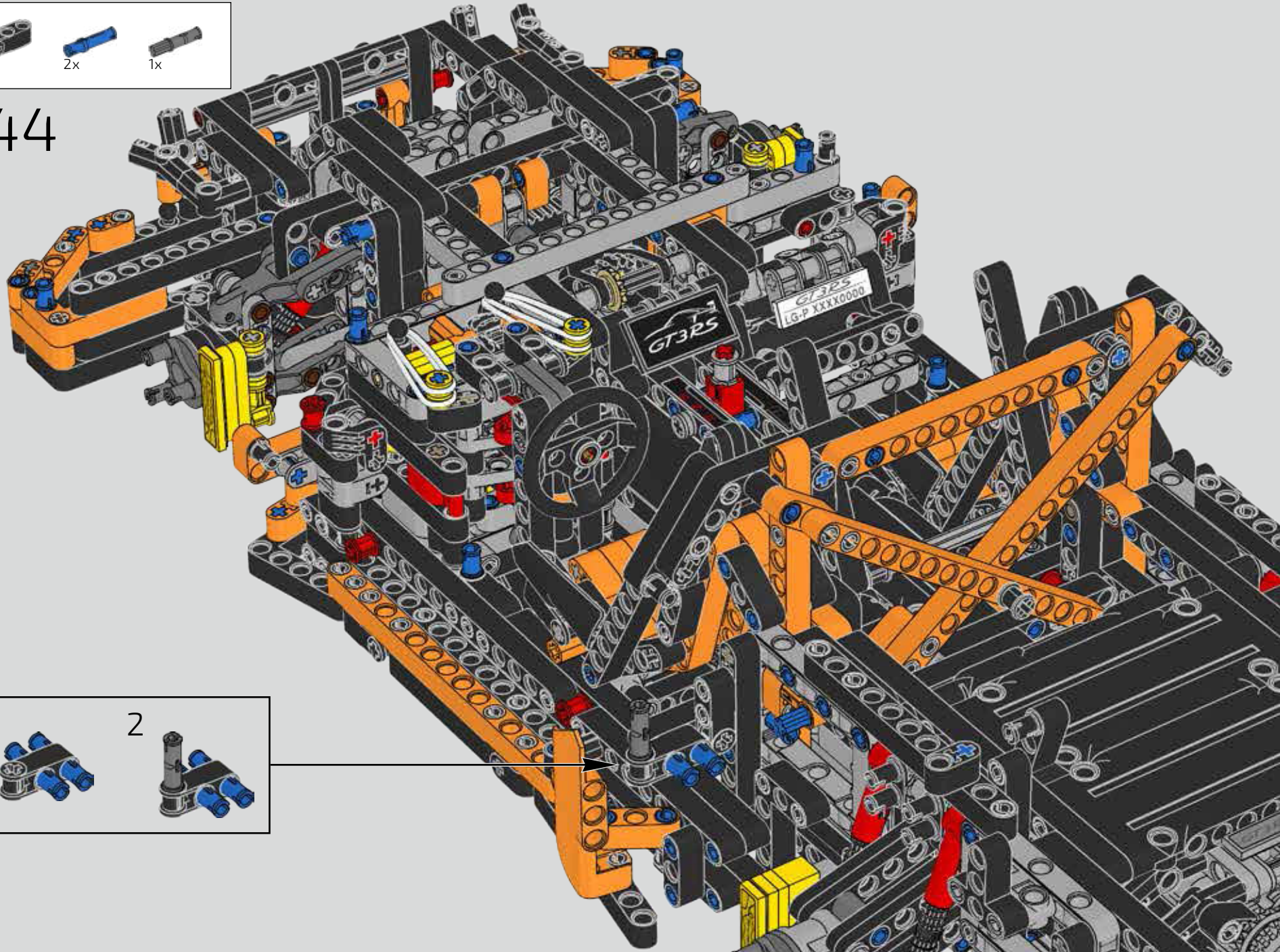

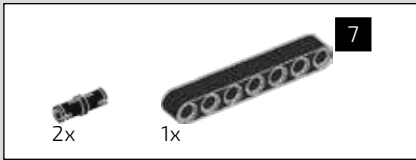

545

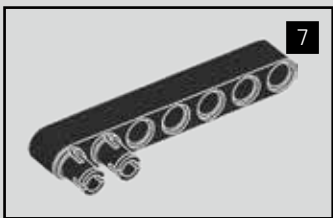
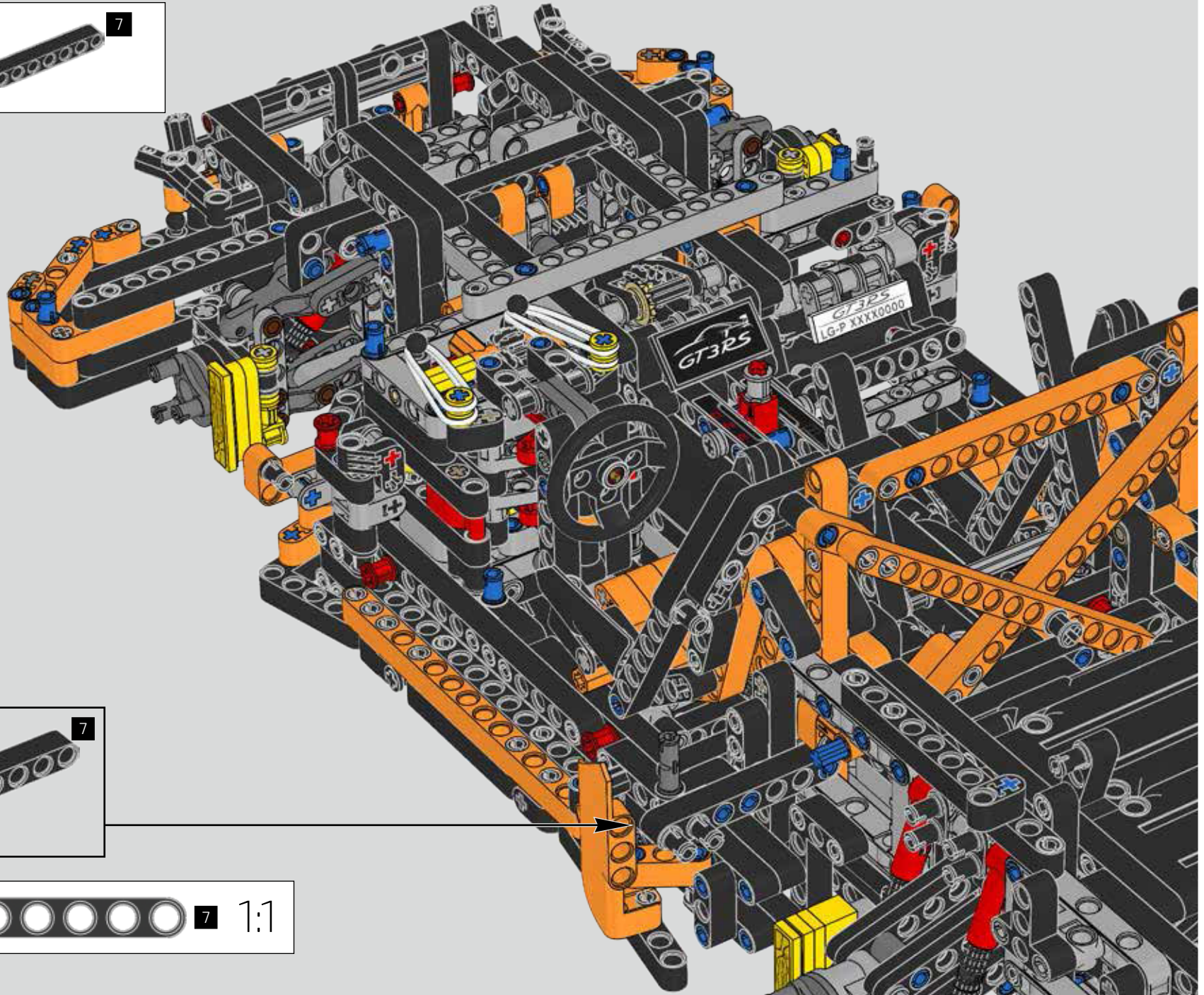

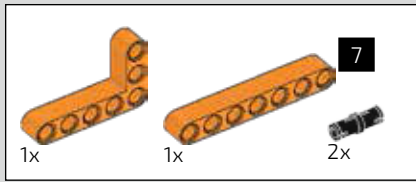

546

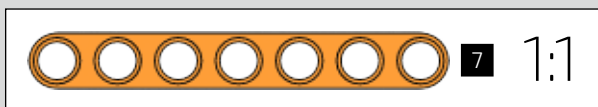
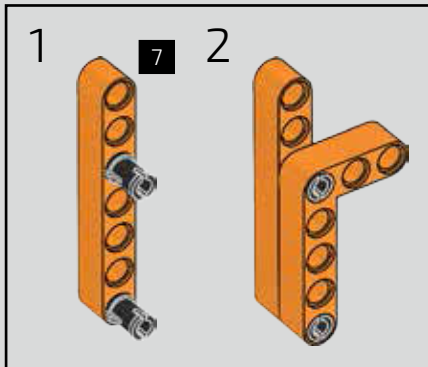
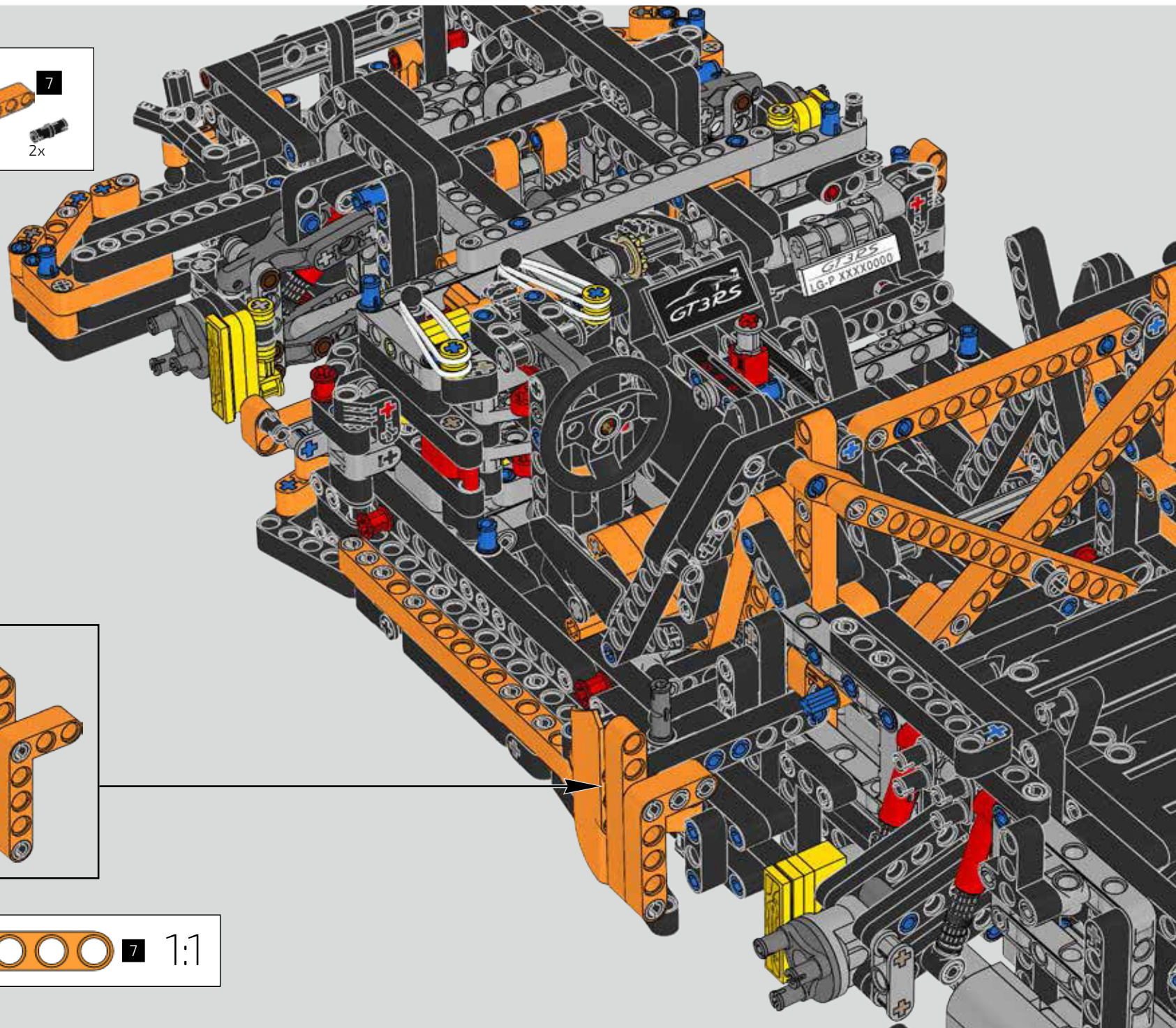

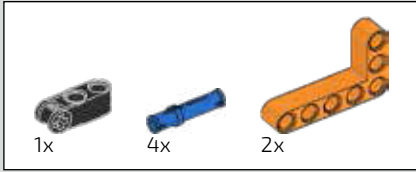

547

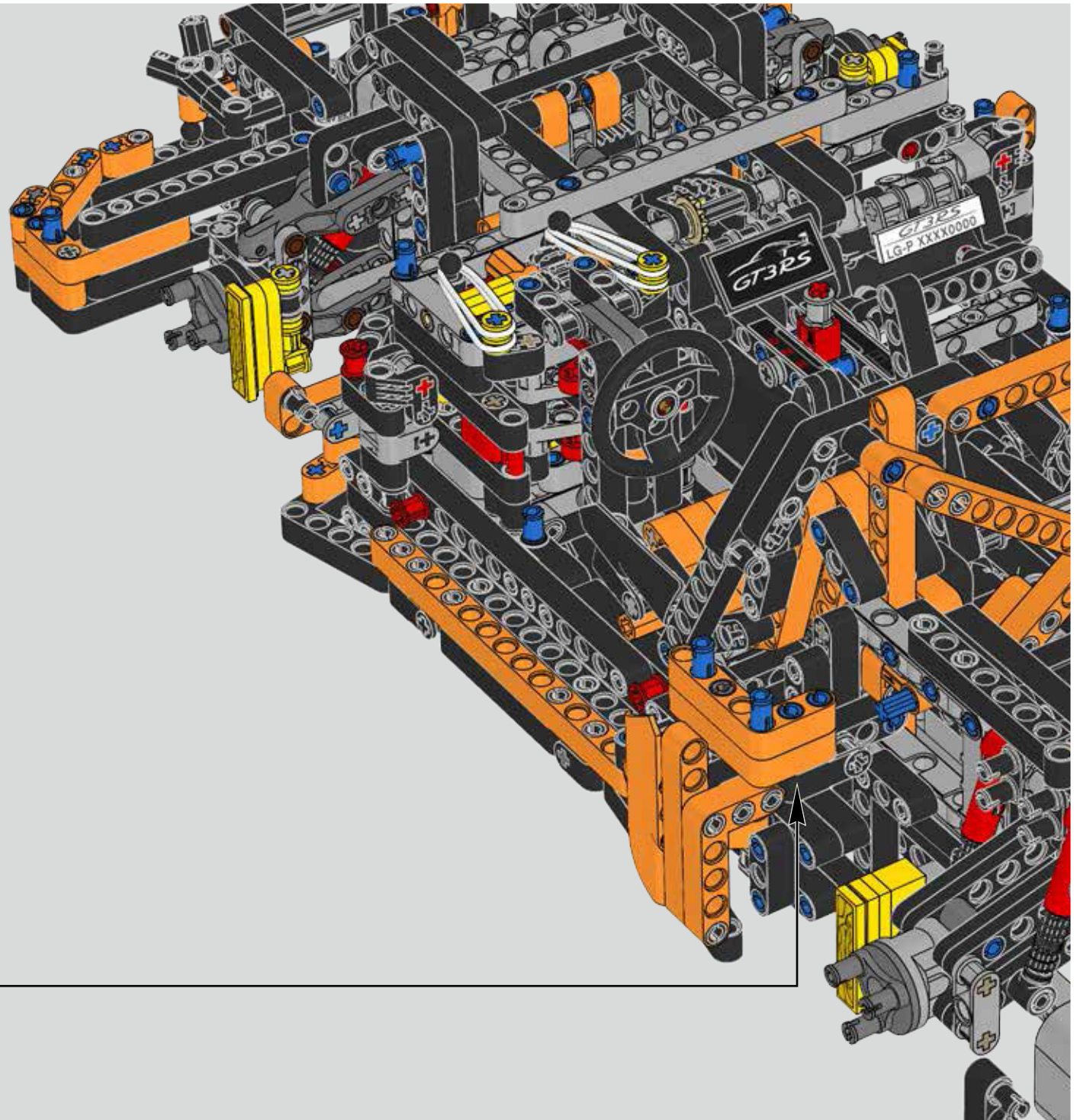
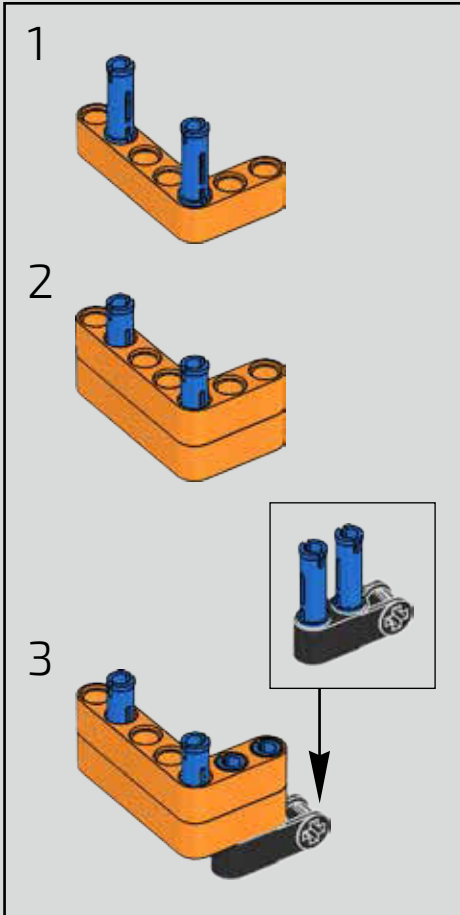

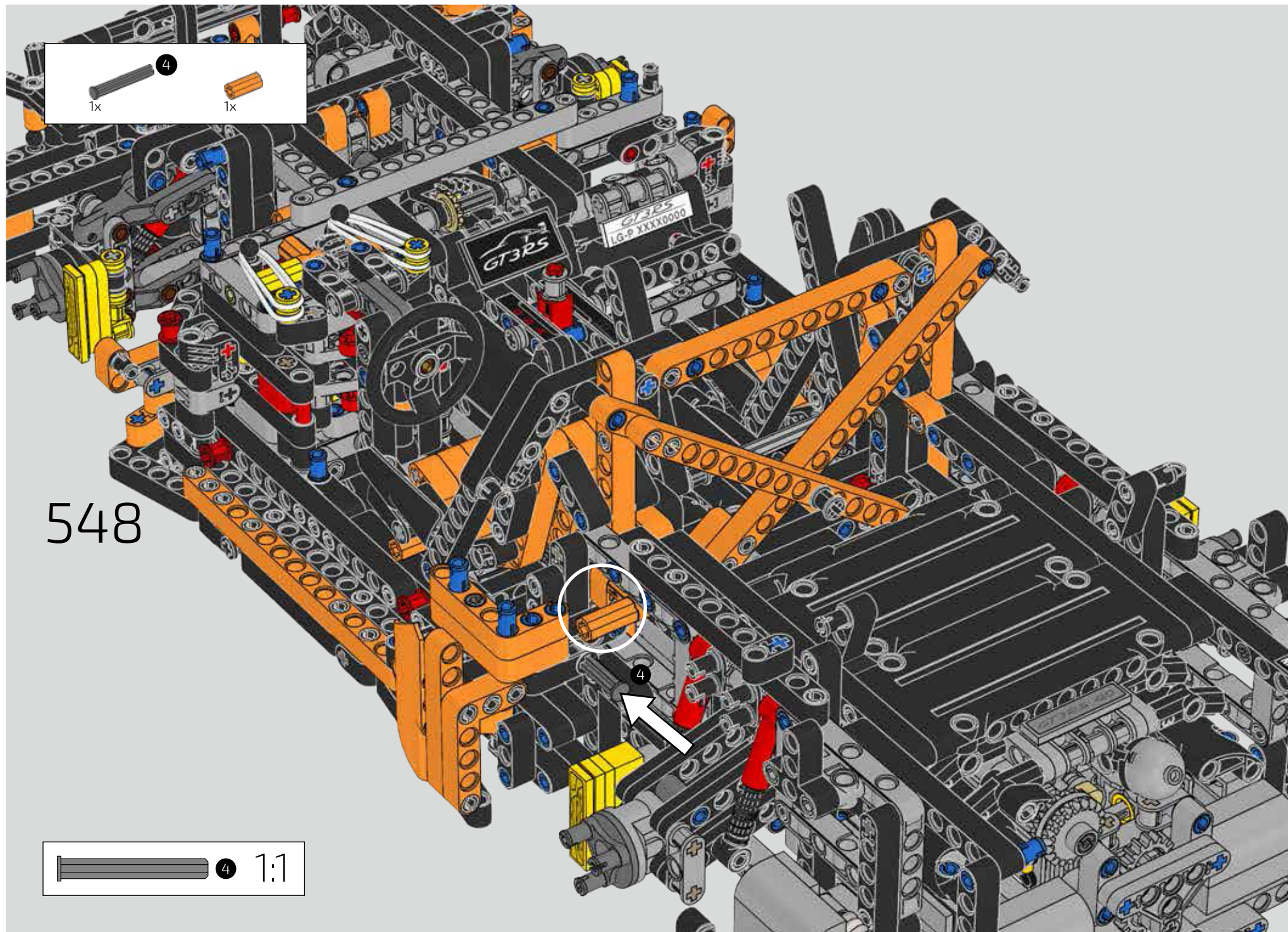

548

4 1:1

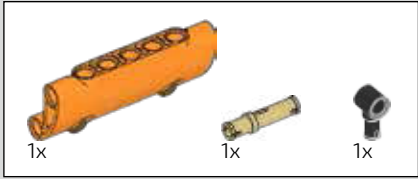

549

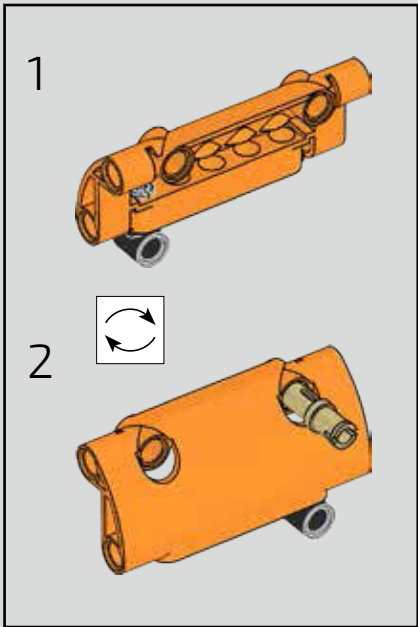
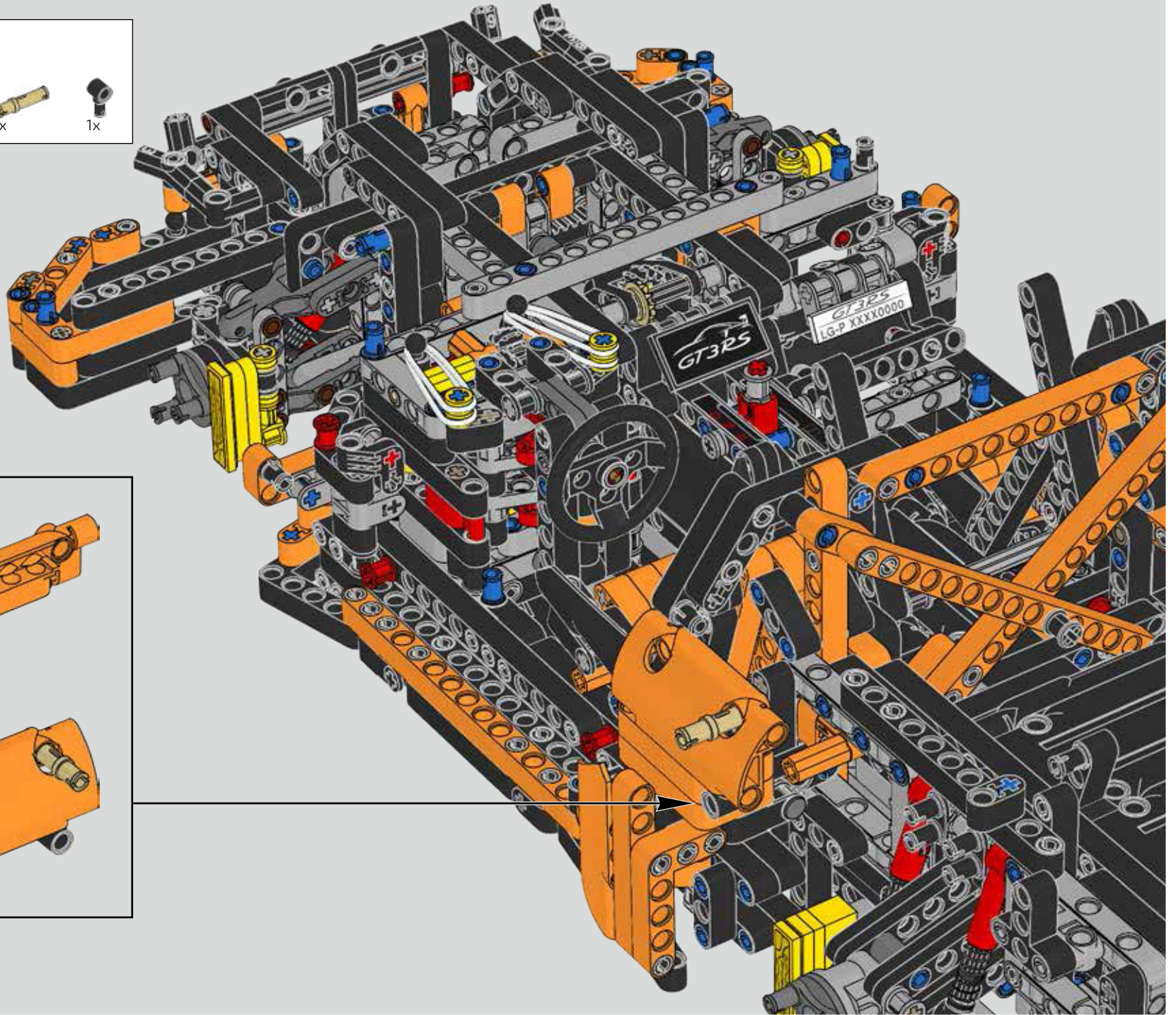

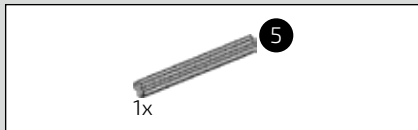

550

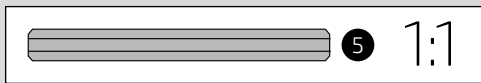
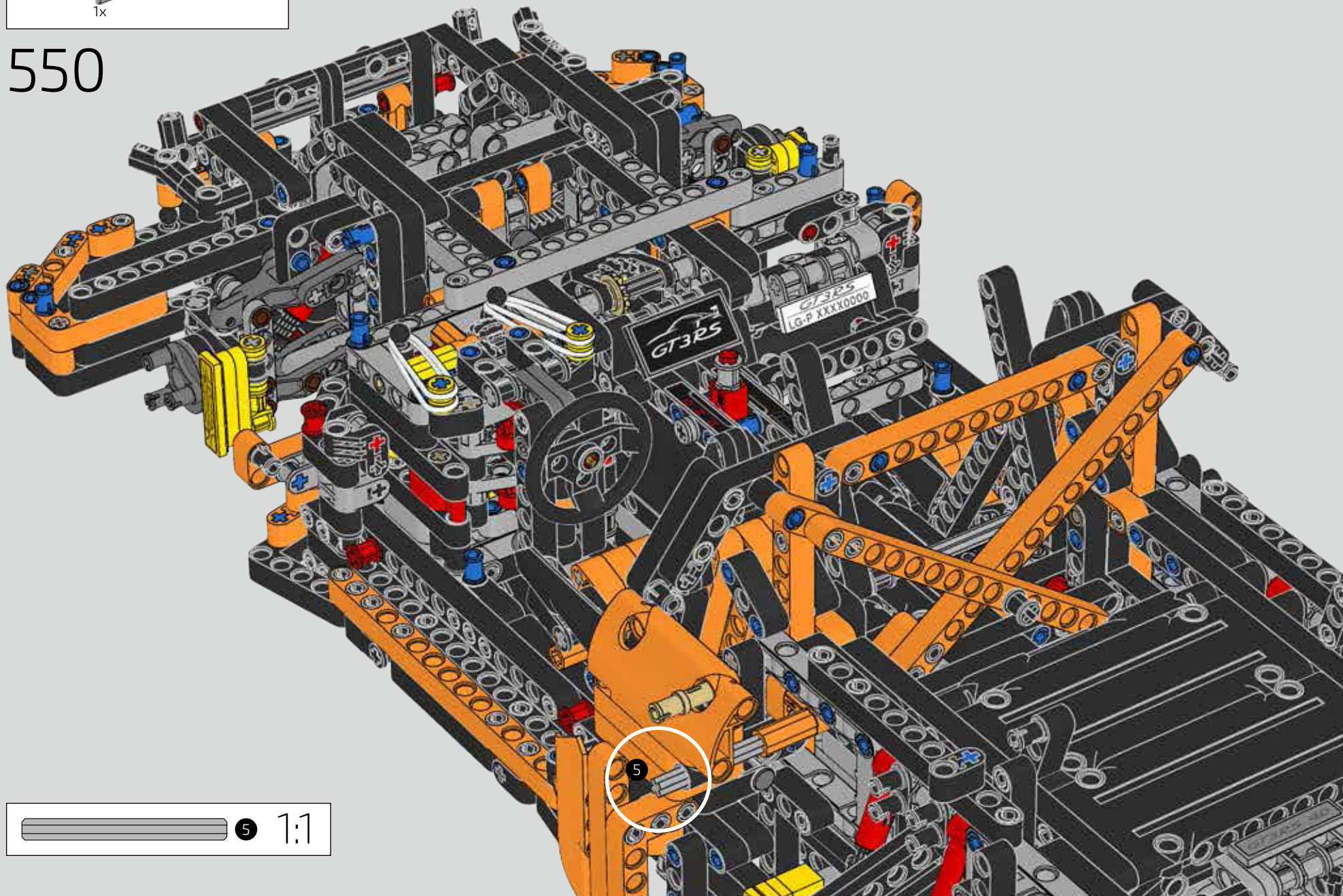



551

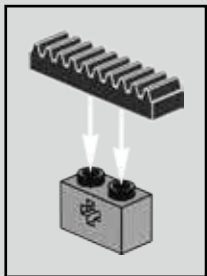
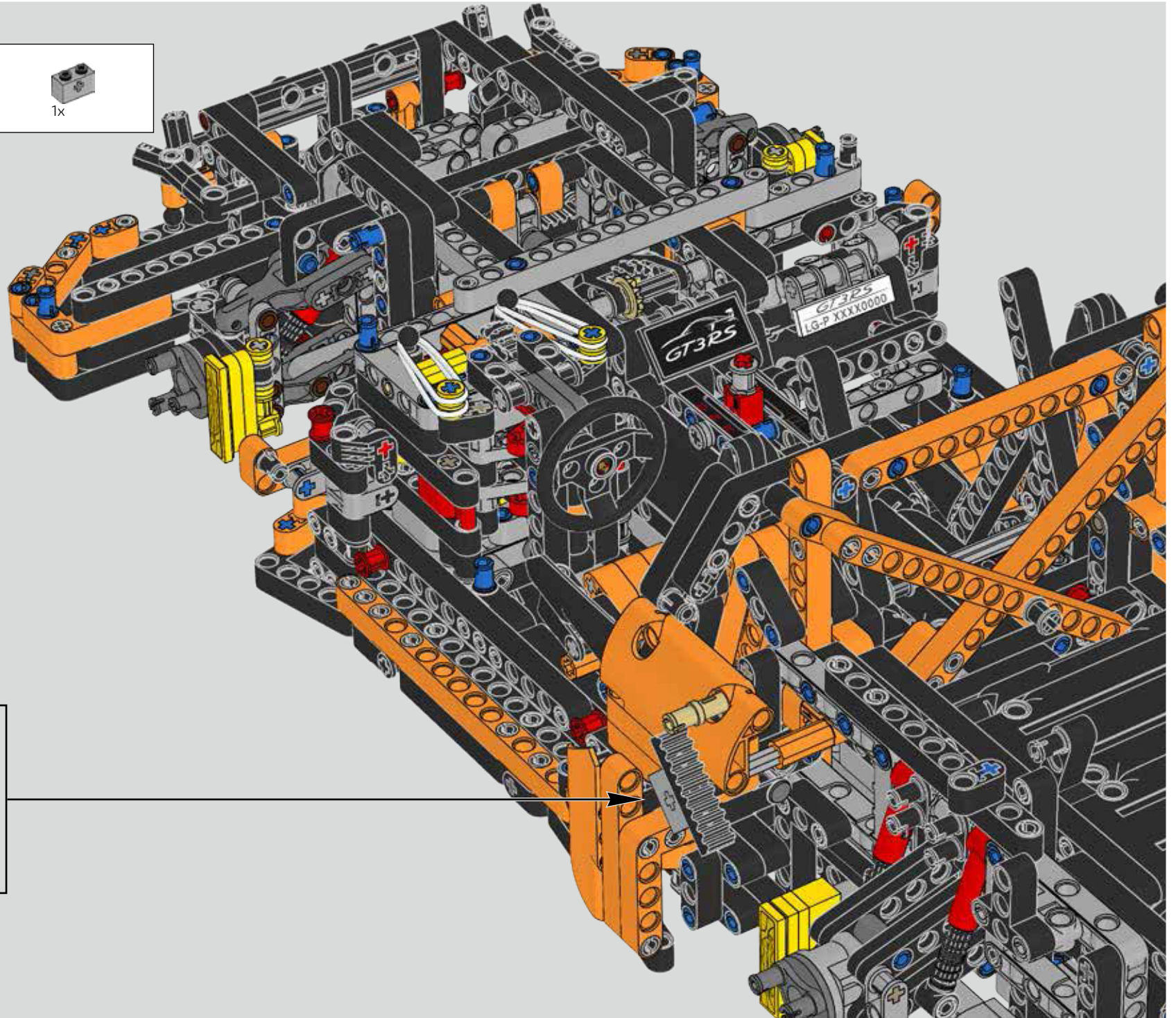

552

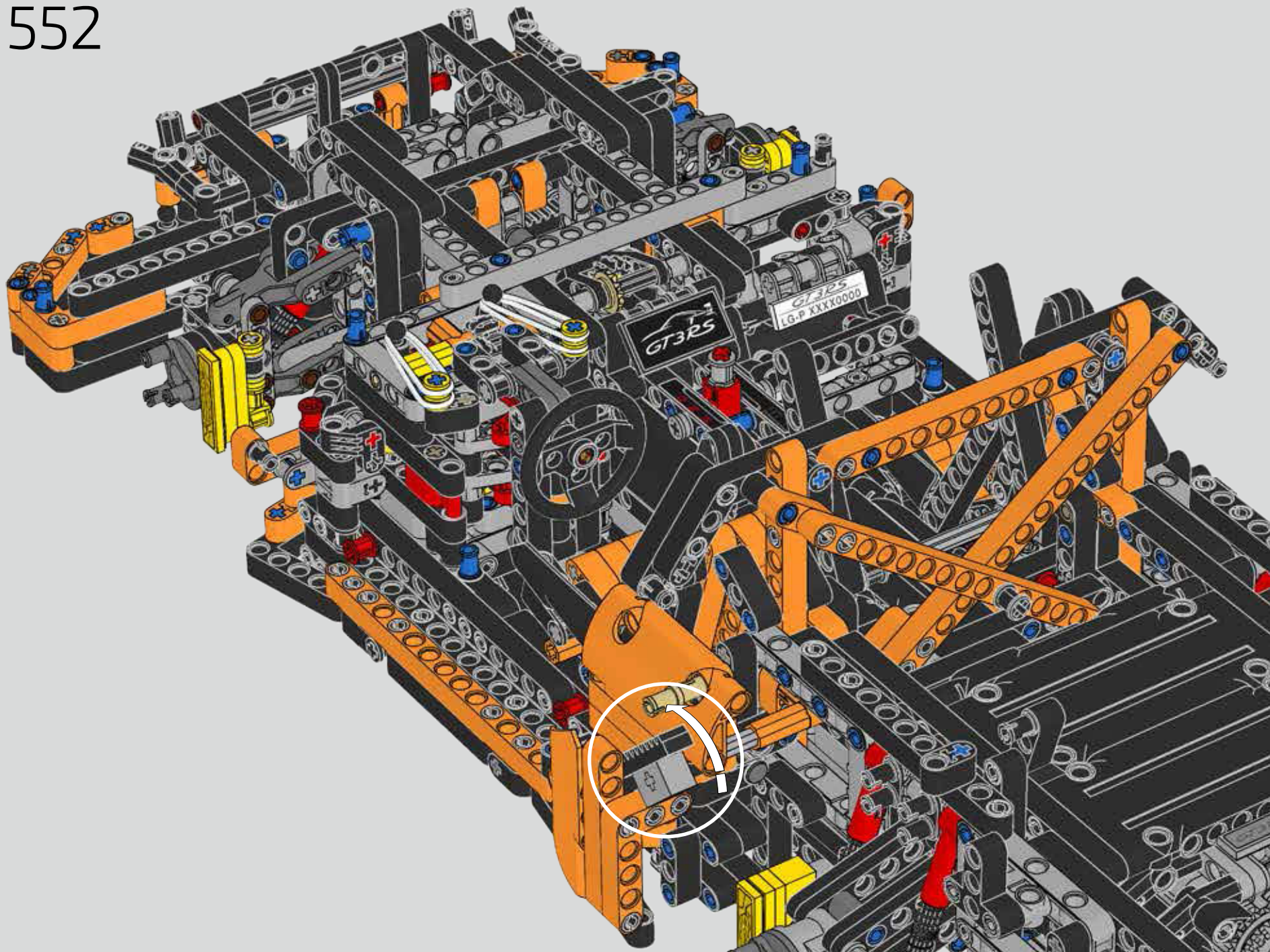

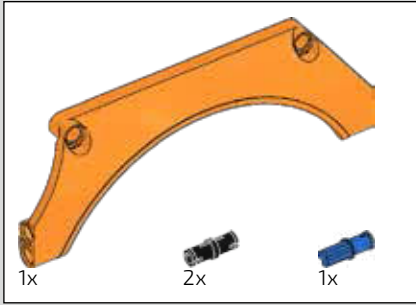

553

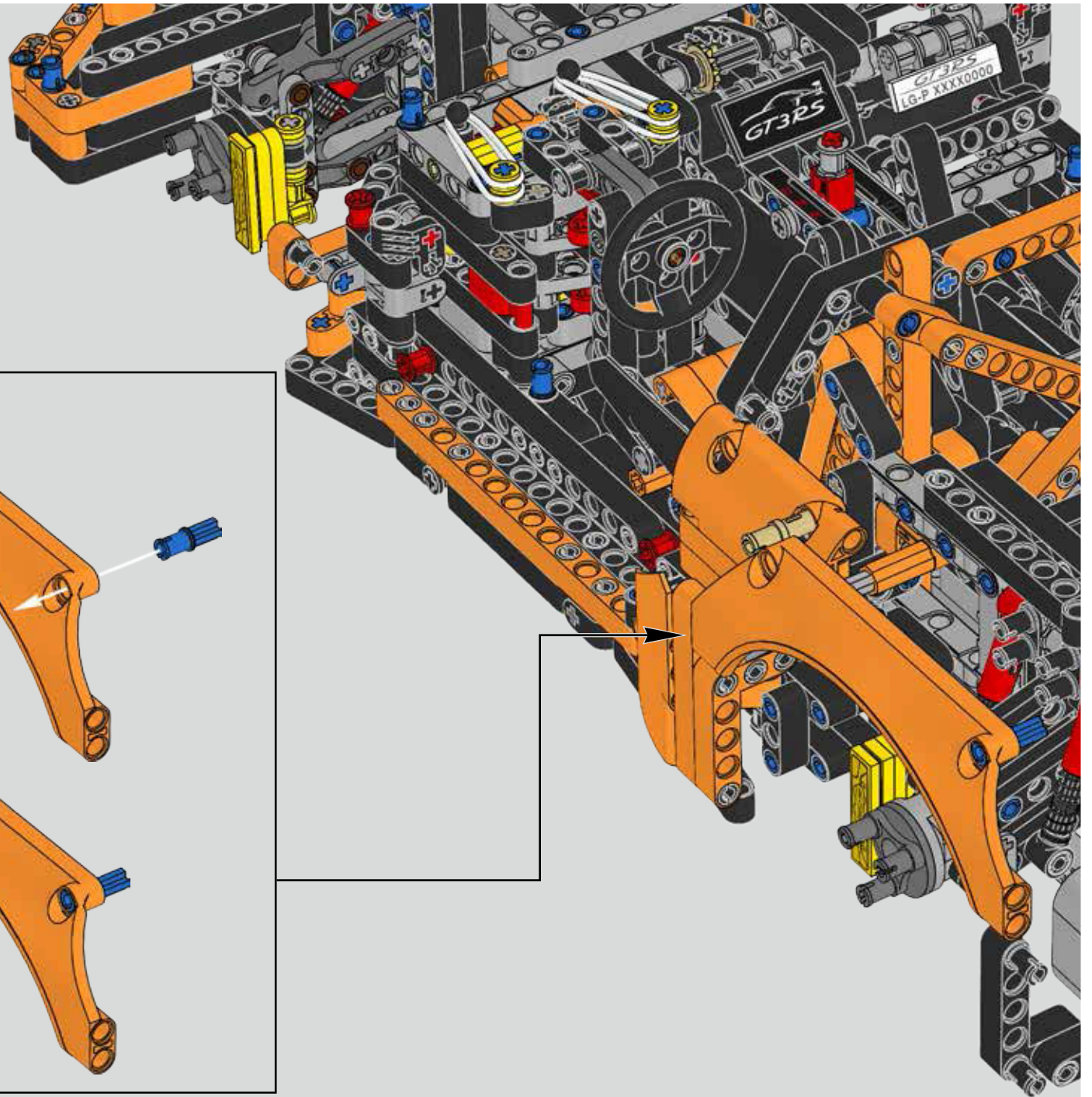
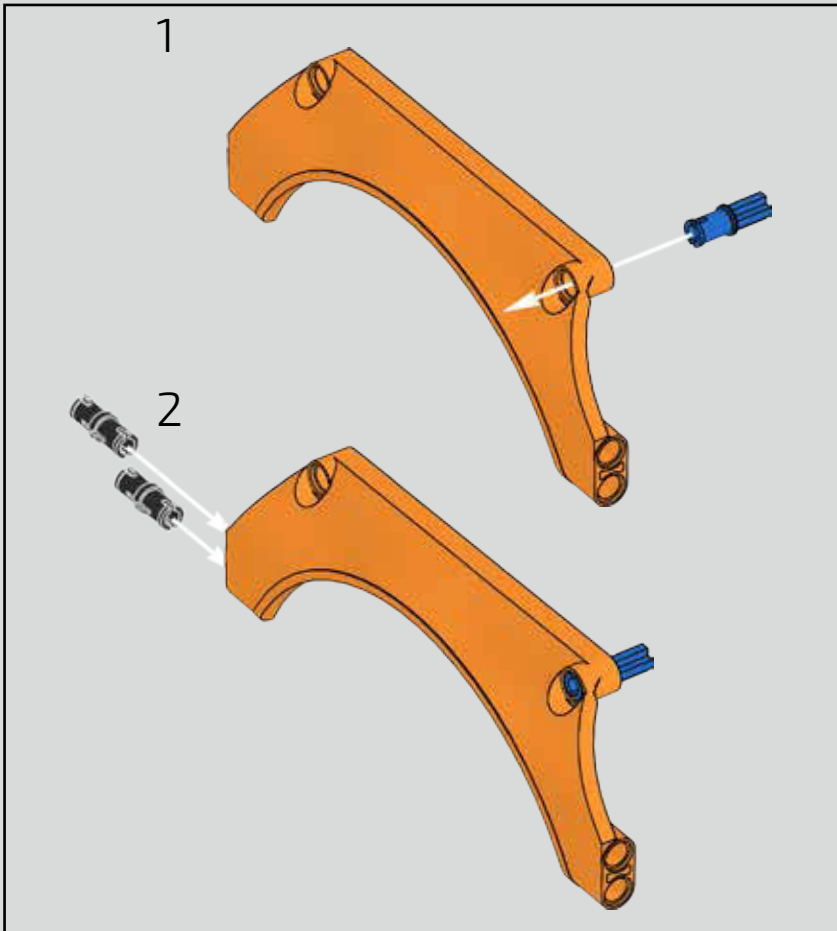

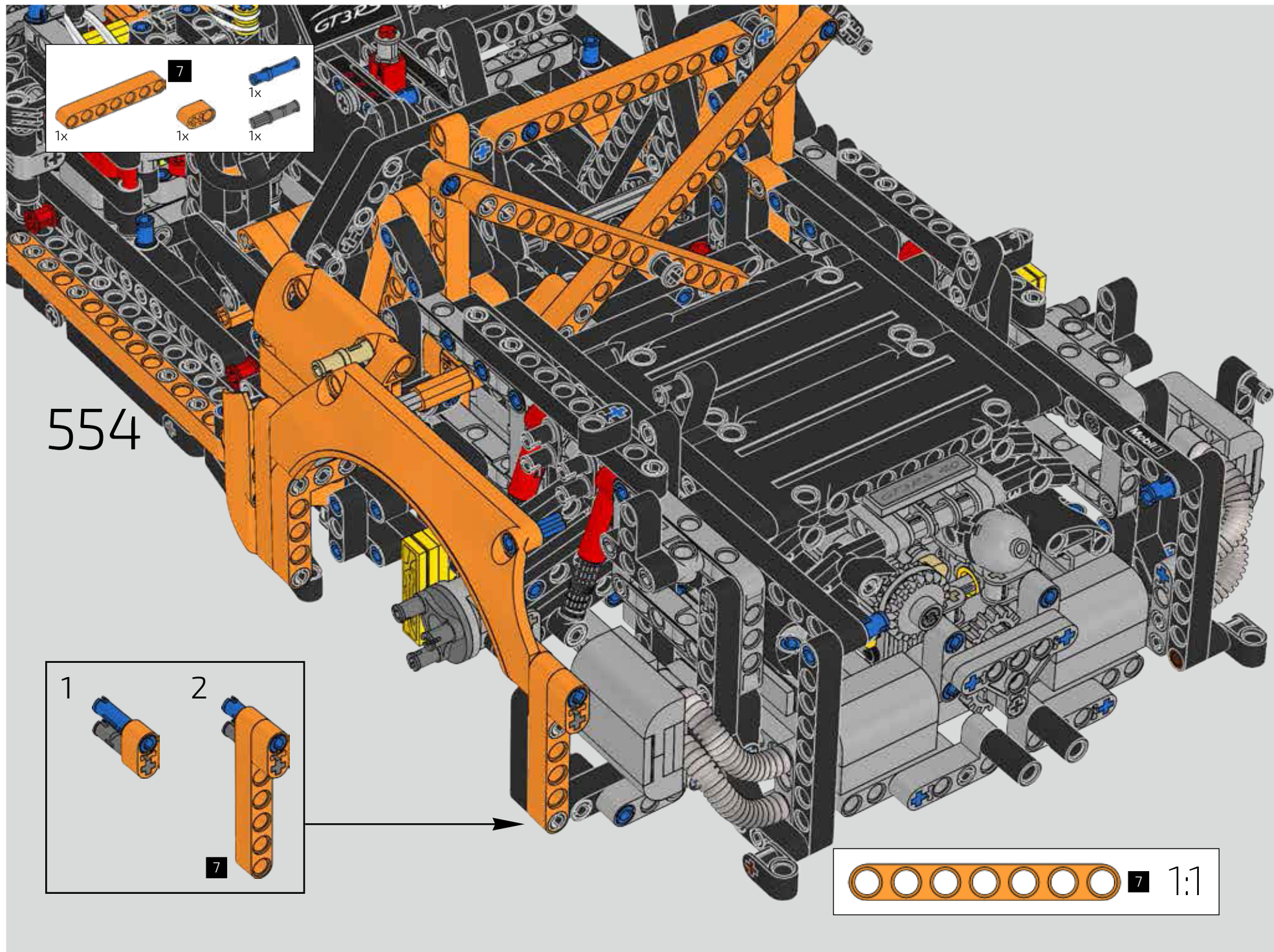

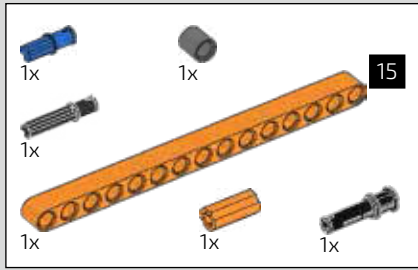

555

1

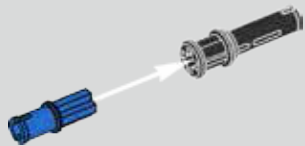

2

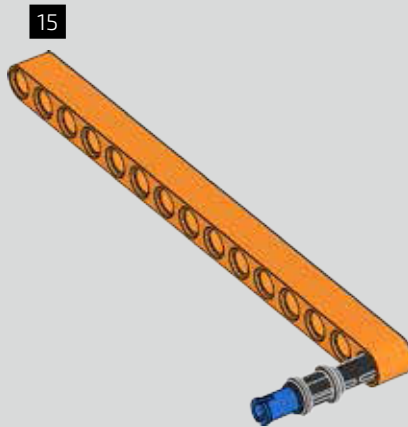

3

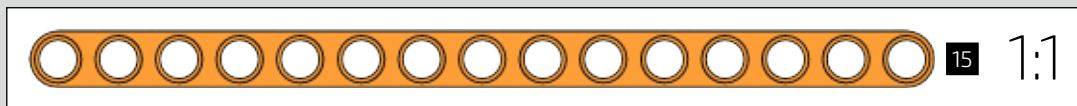
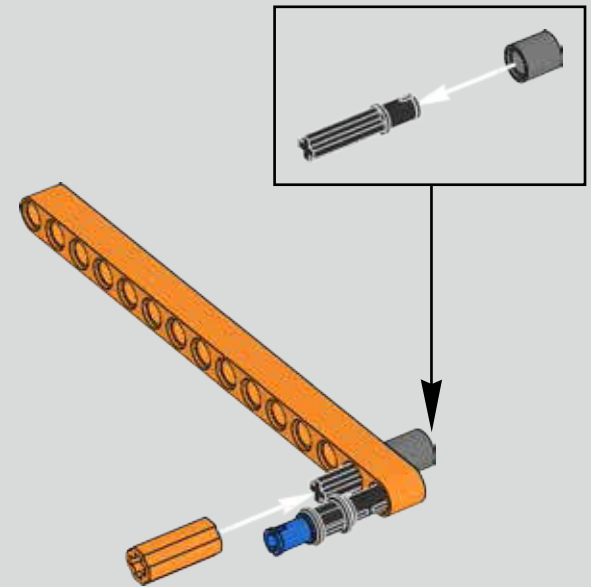

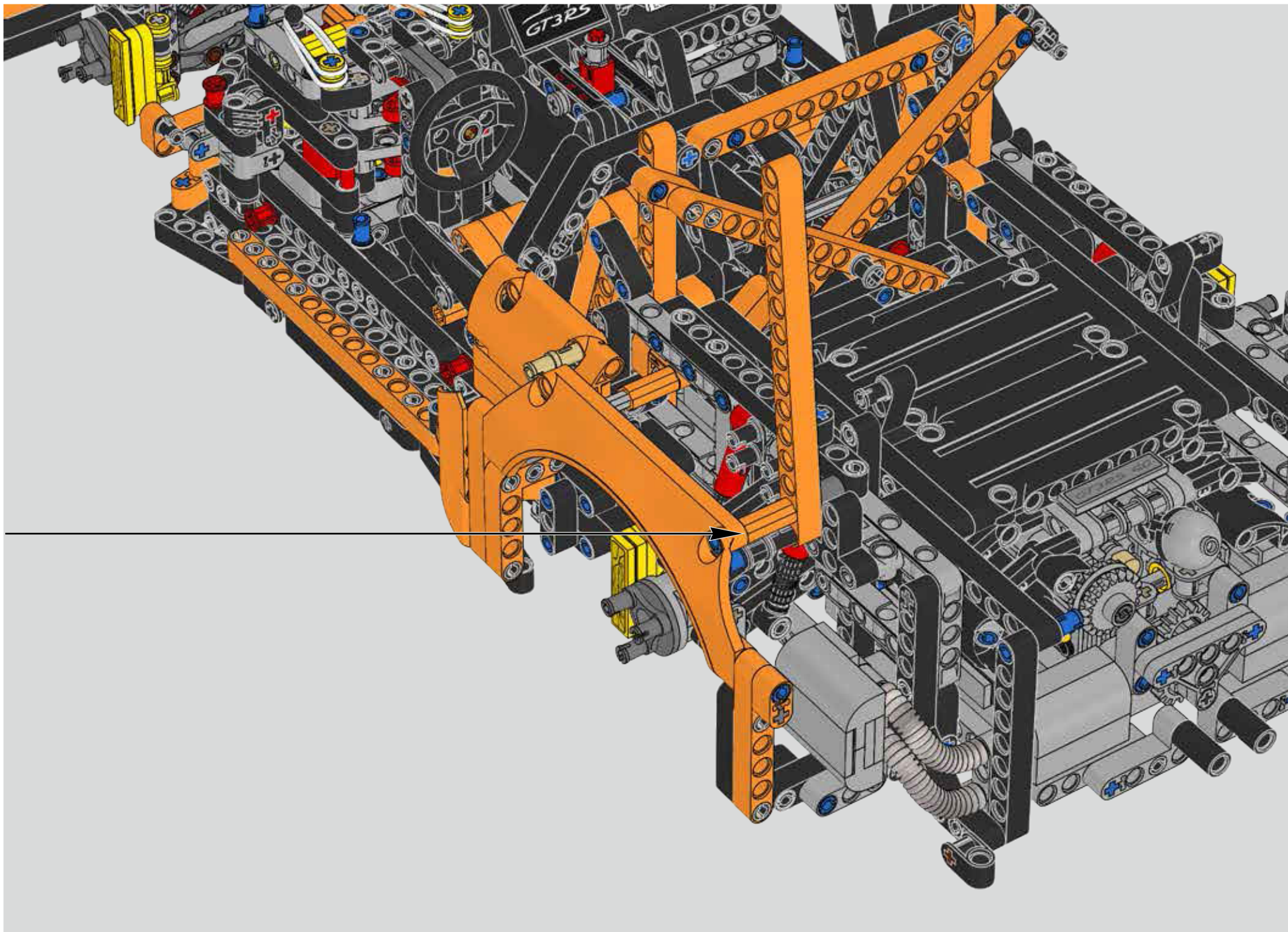

556

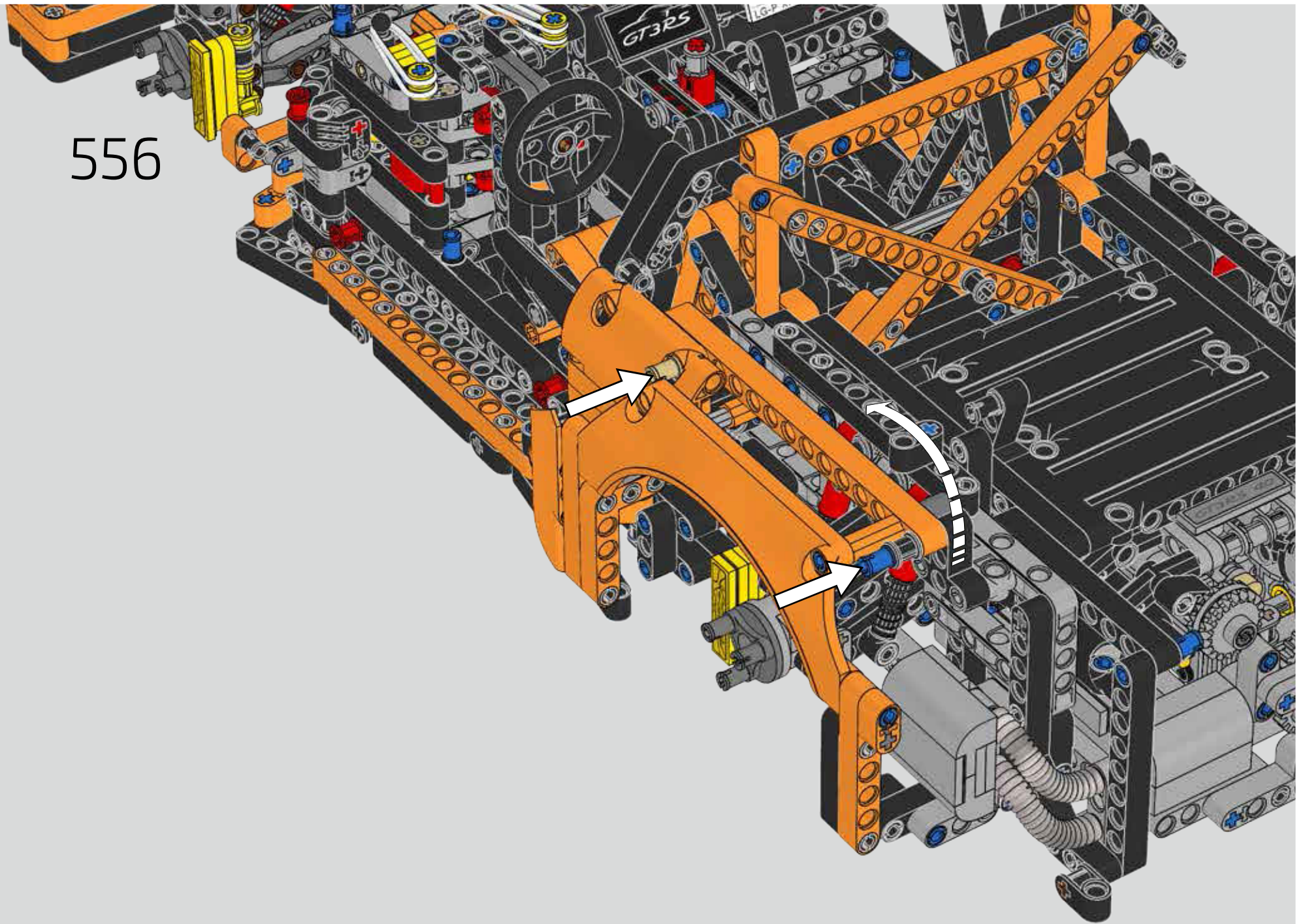

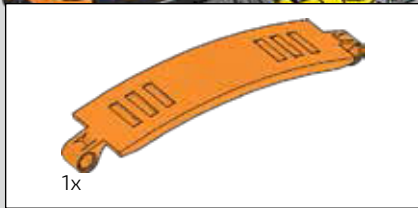

557

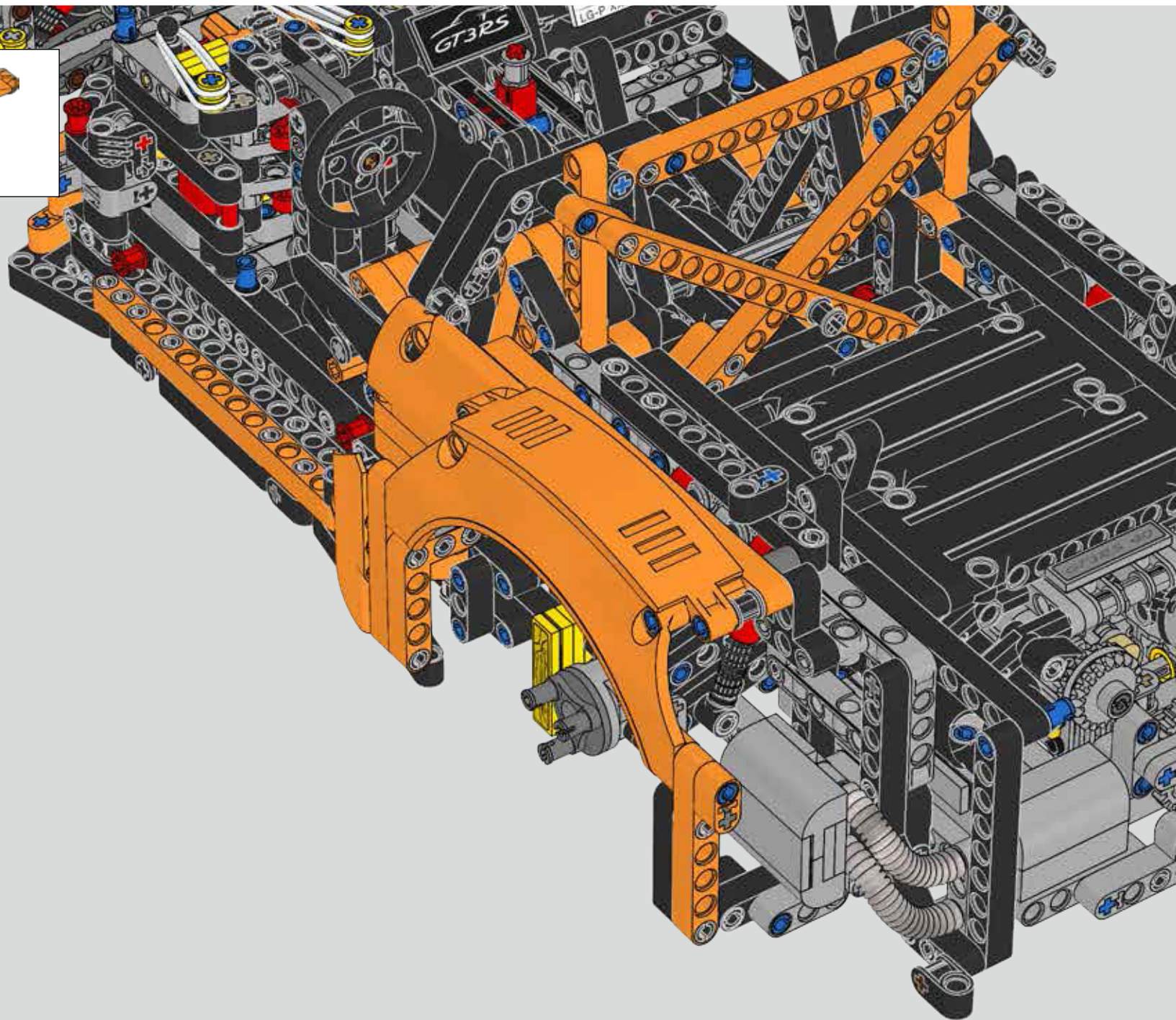

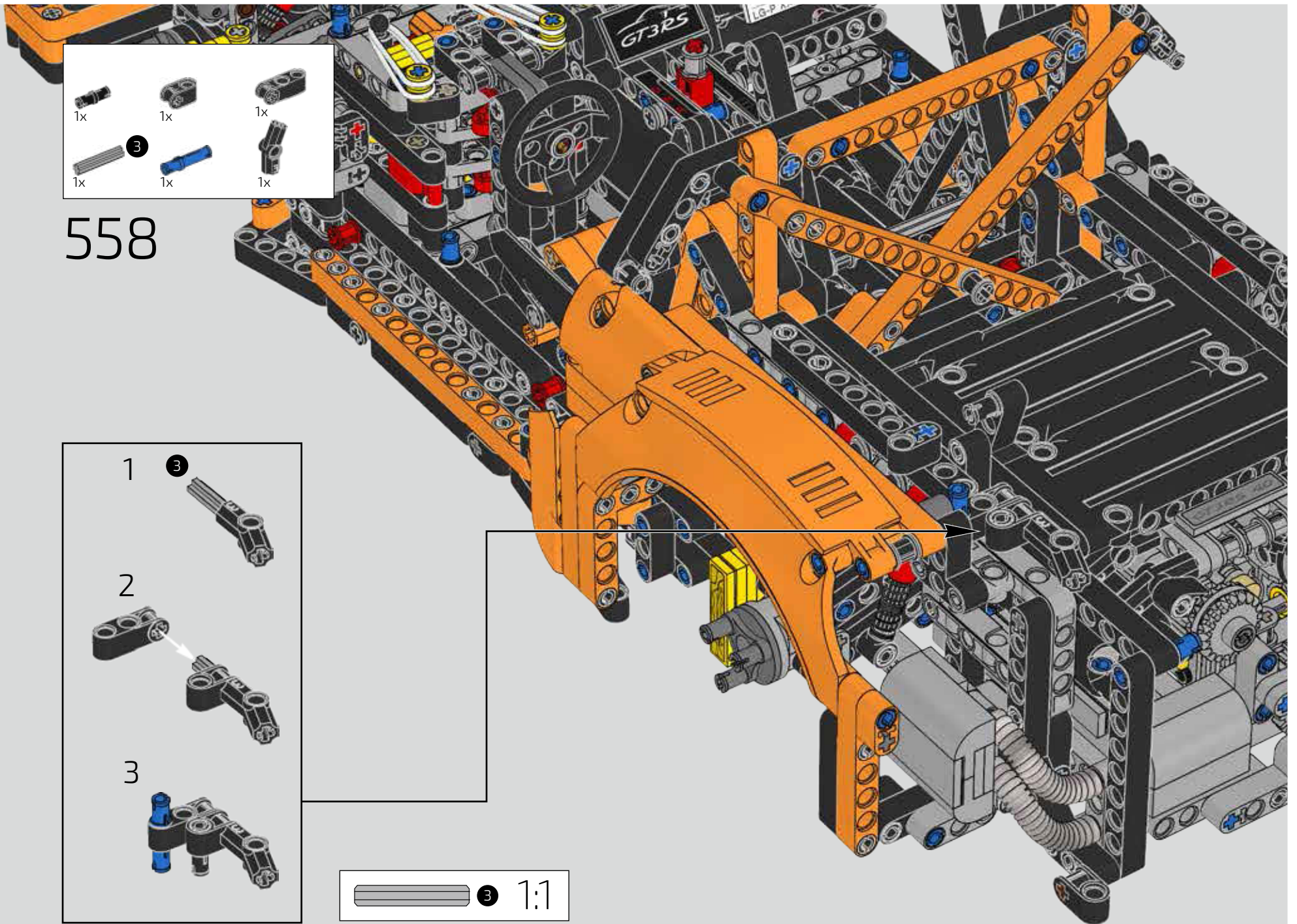

- 1x
- 1x
- 1x
- 1x
- 1x
- 1x

558

- 1 **3**
- 2
- 3

1:1

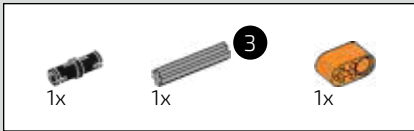

559

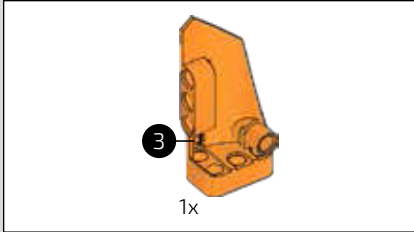
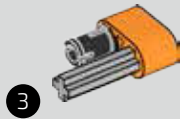

560

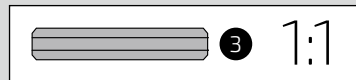
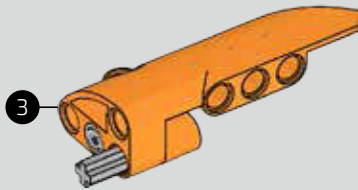

561

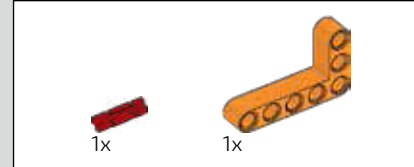
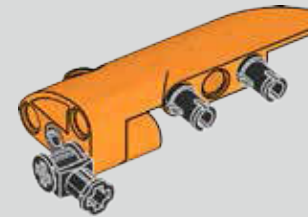

562

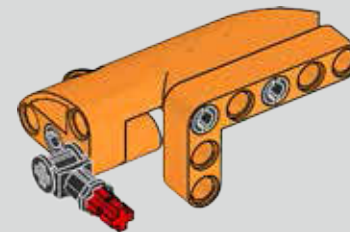

563

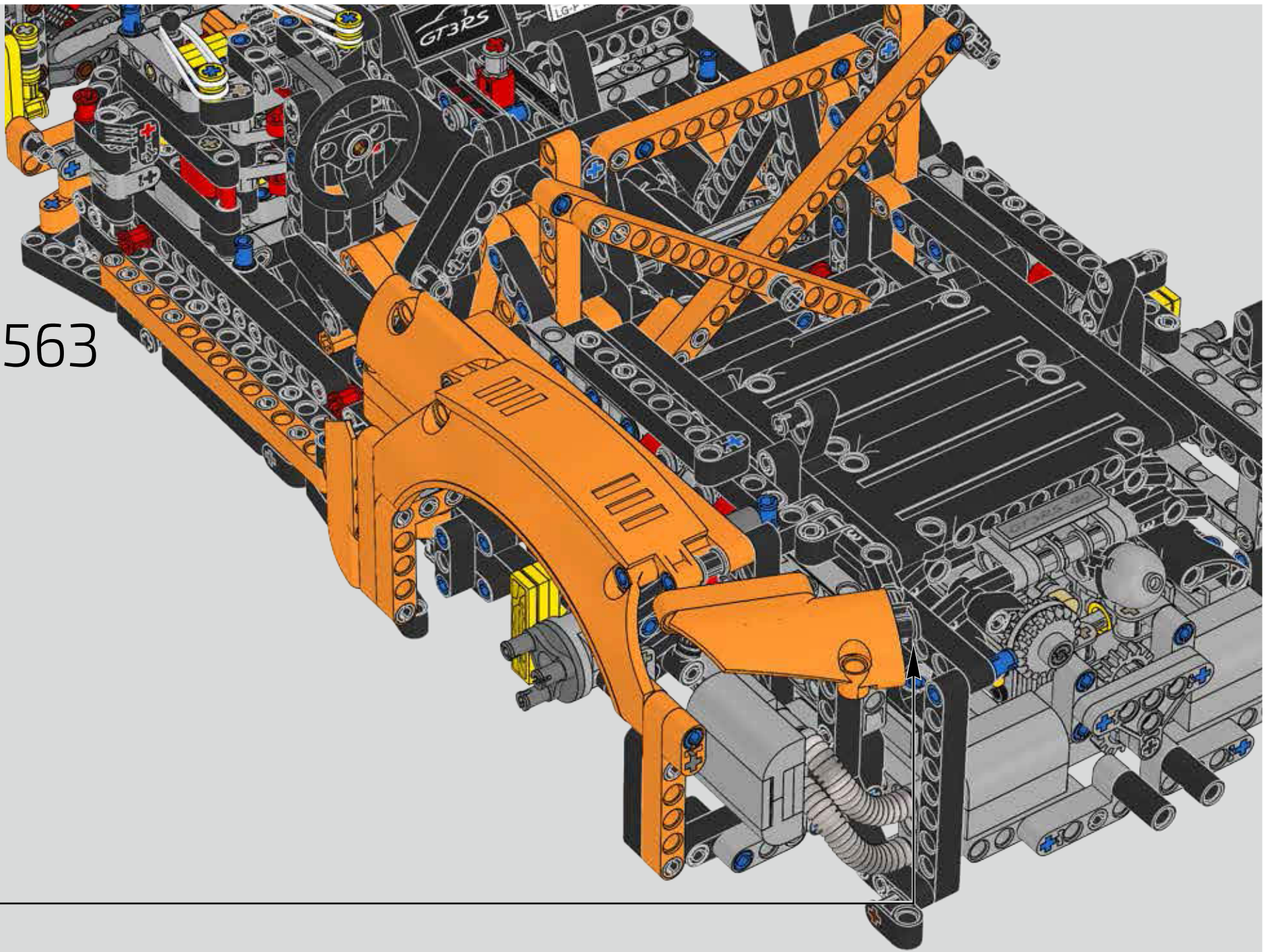

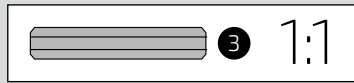
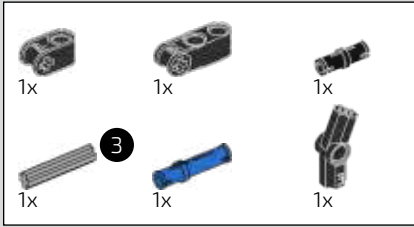

564

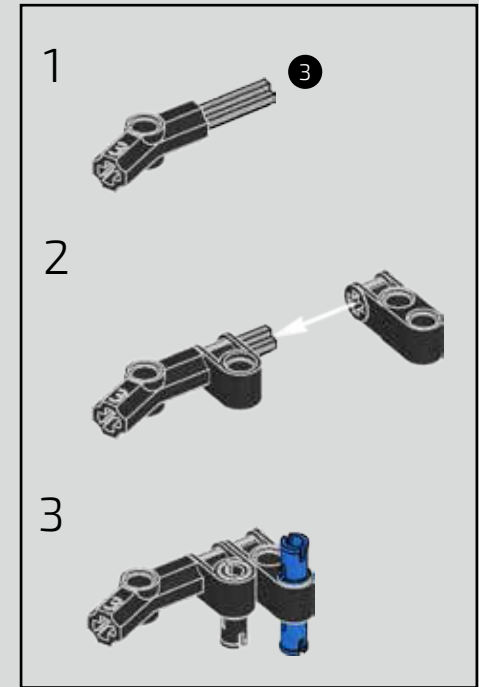
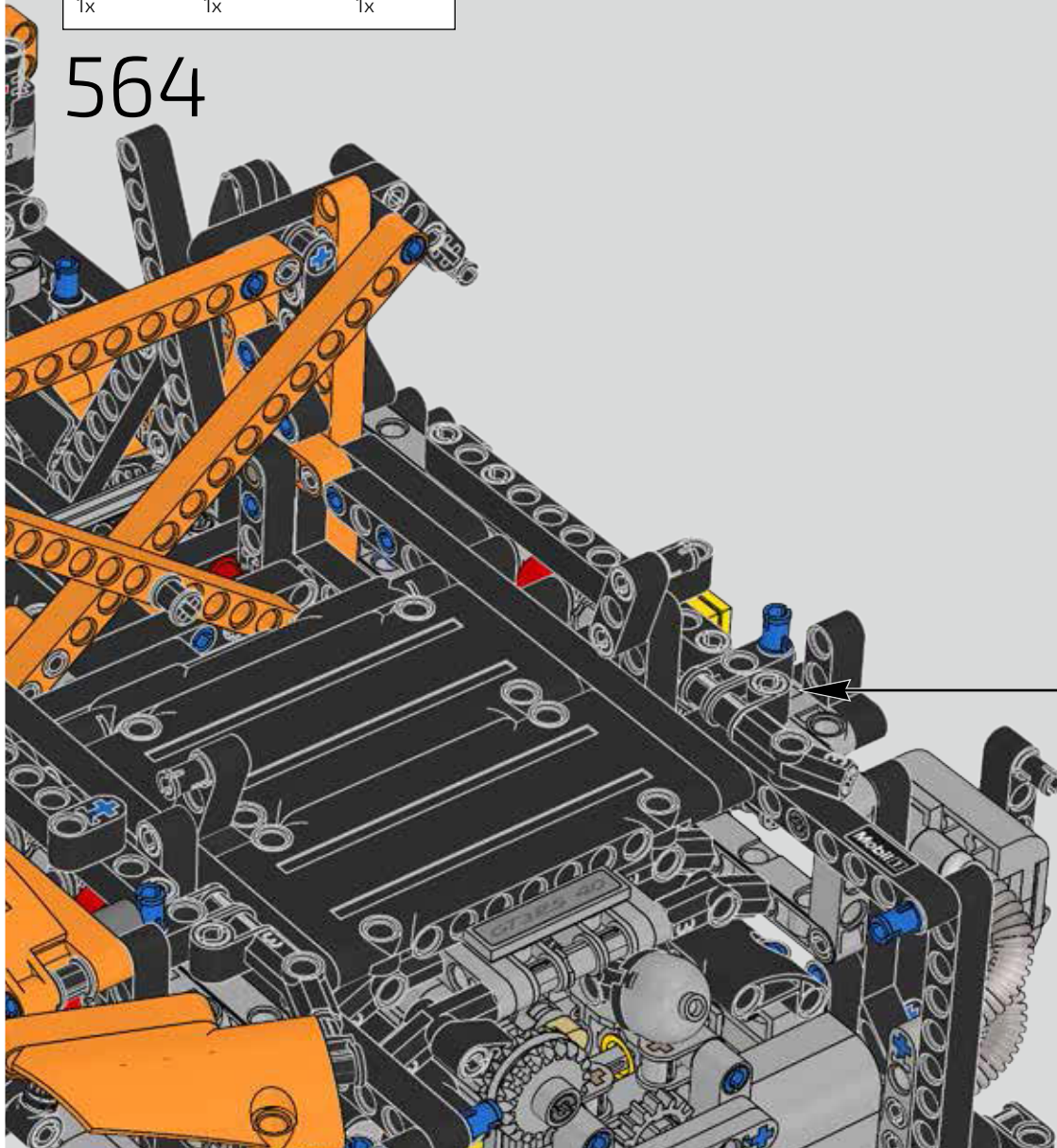

565

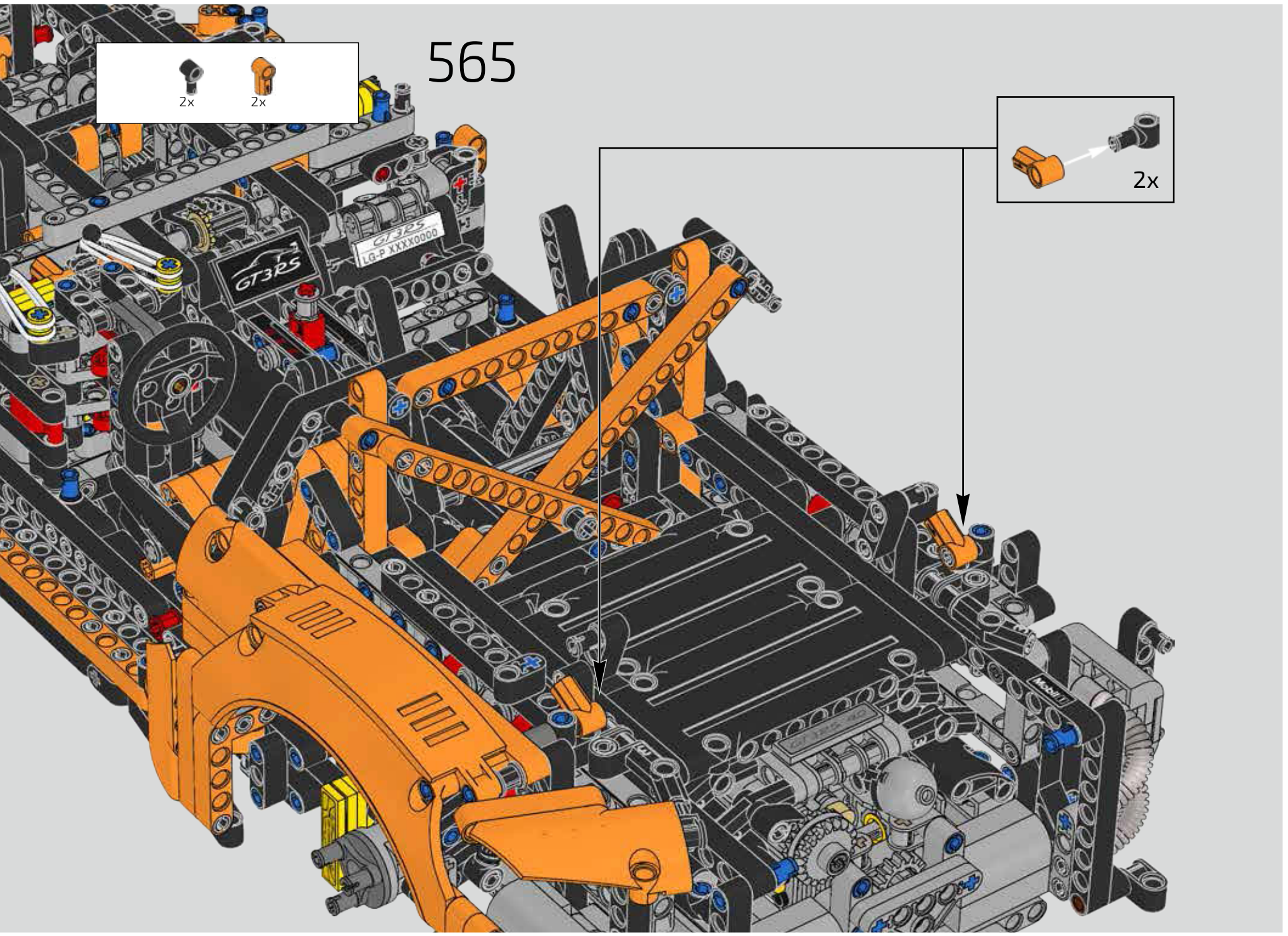
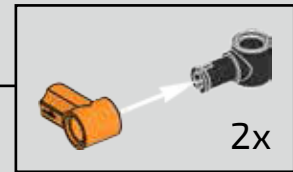
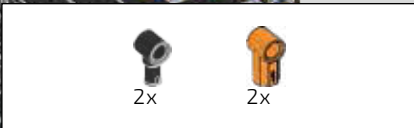

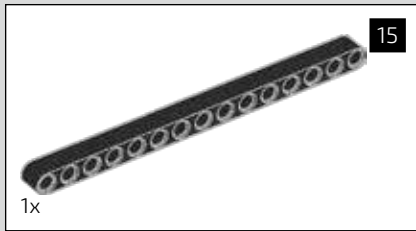

566

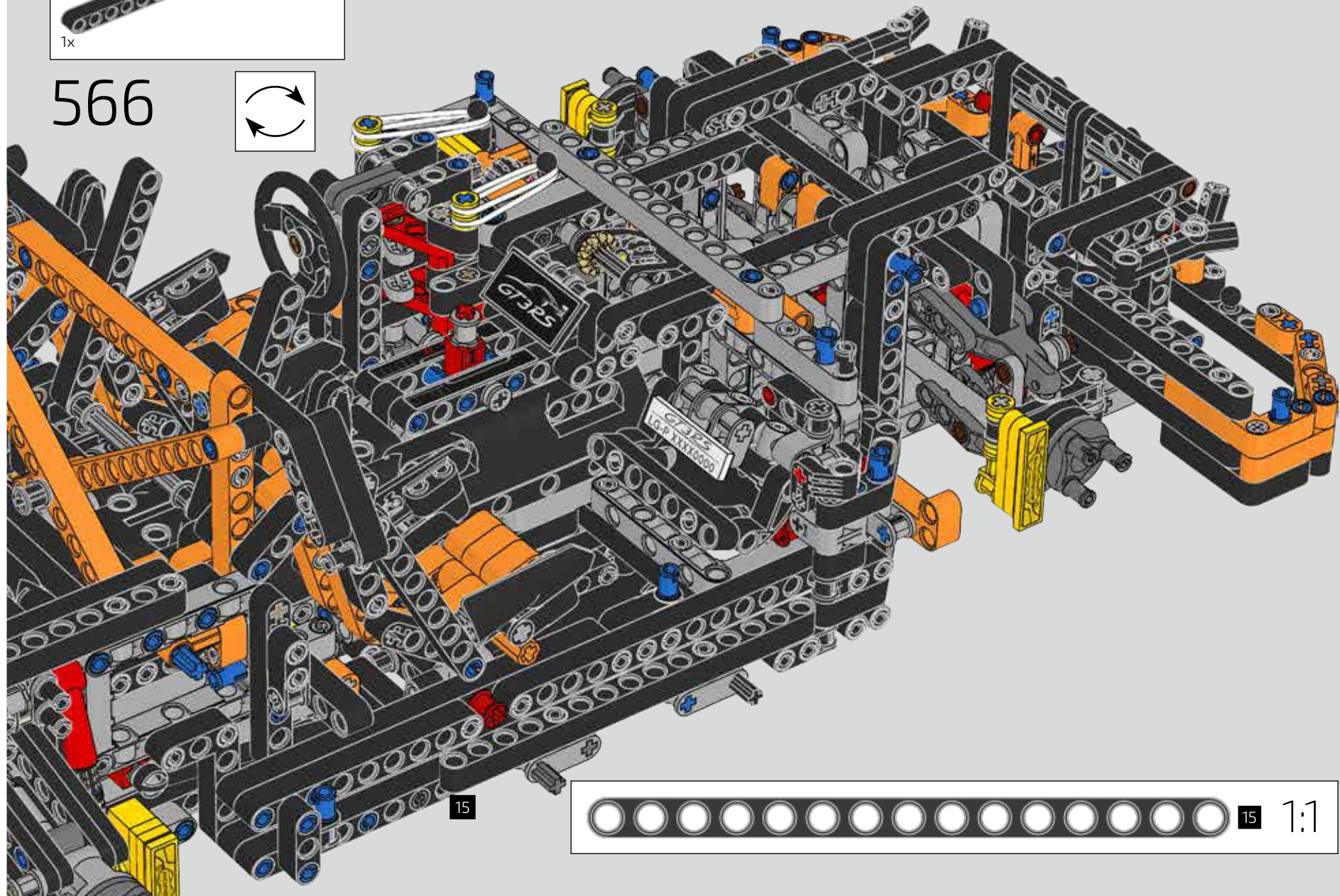
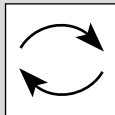

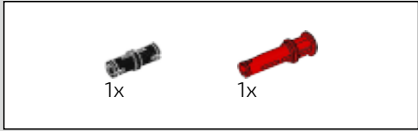

567

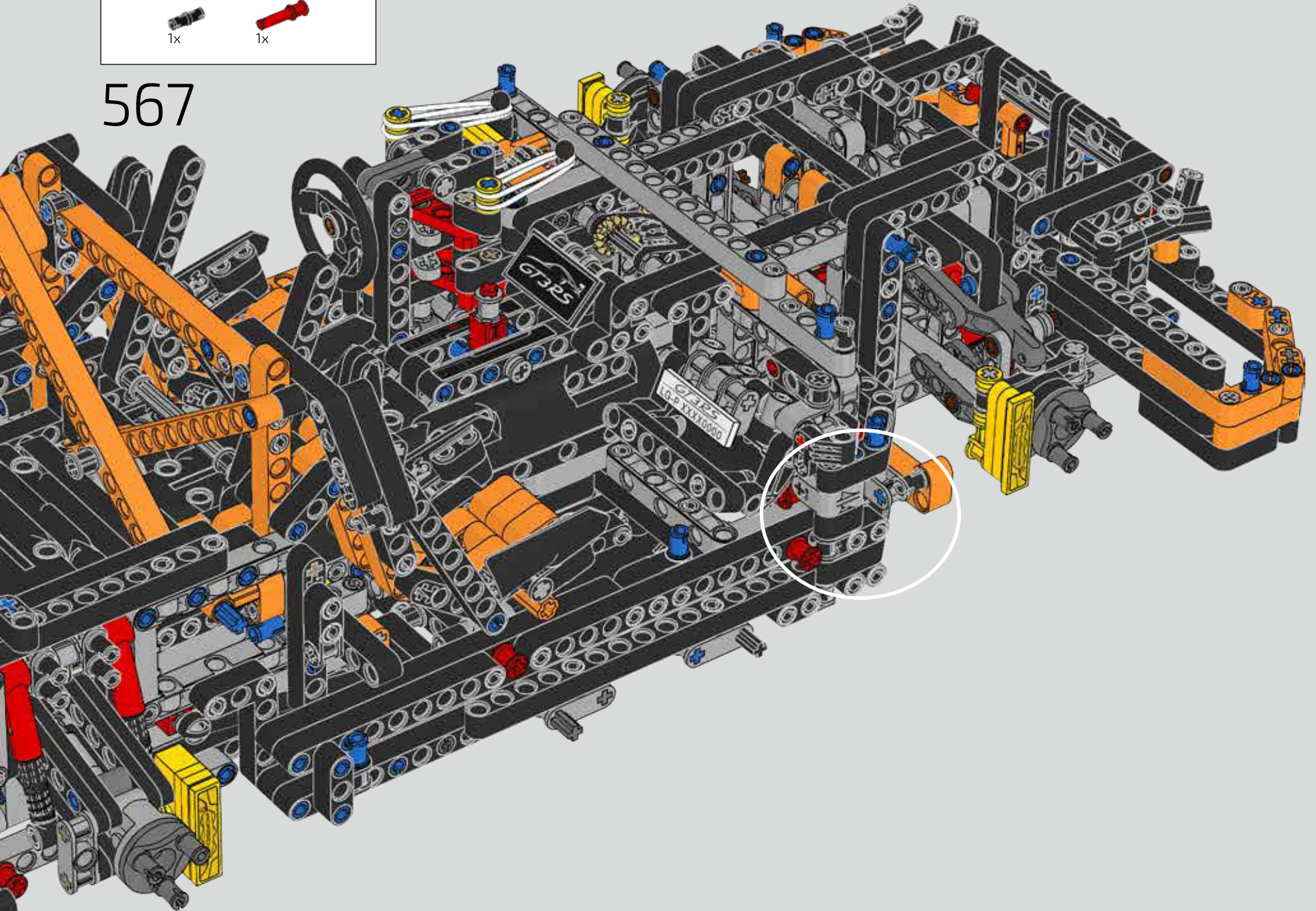

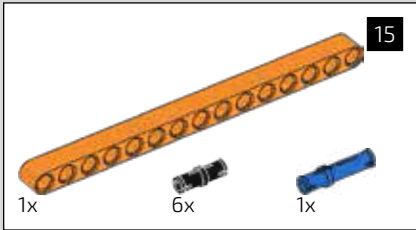
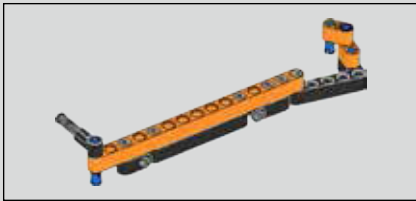

568

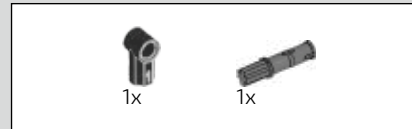
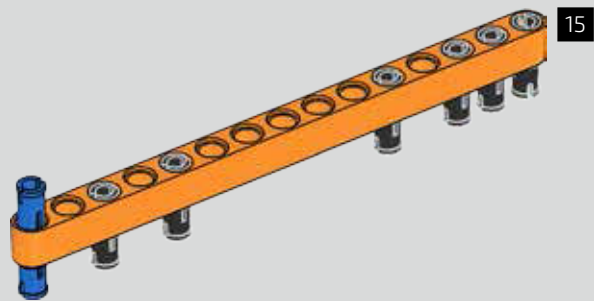

569

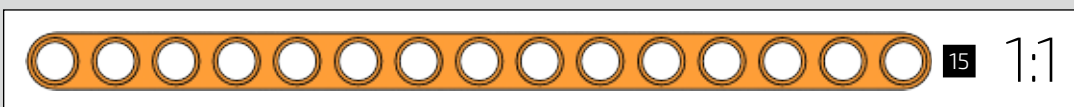
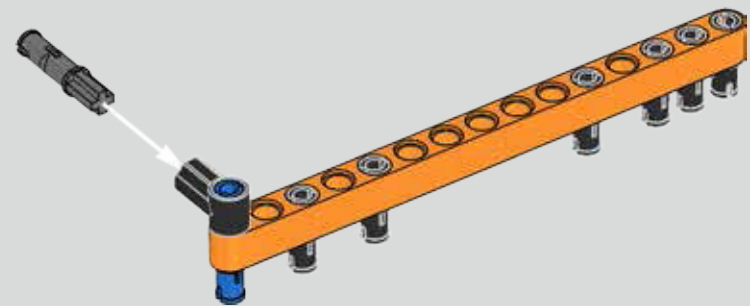

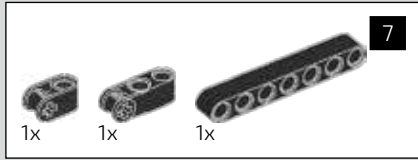

570

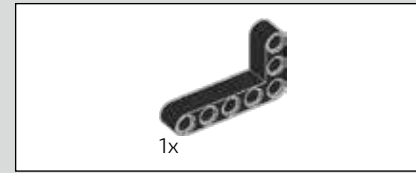
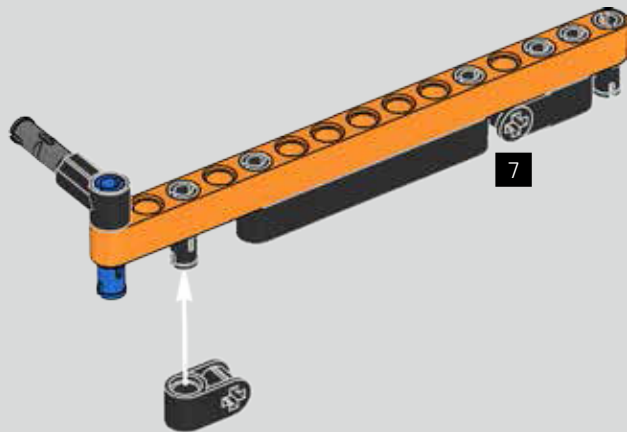

571

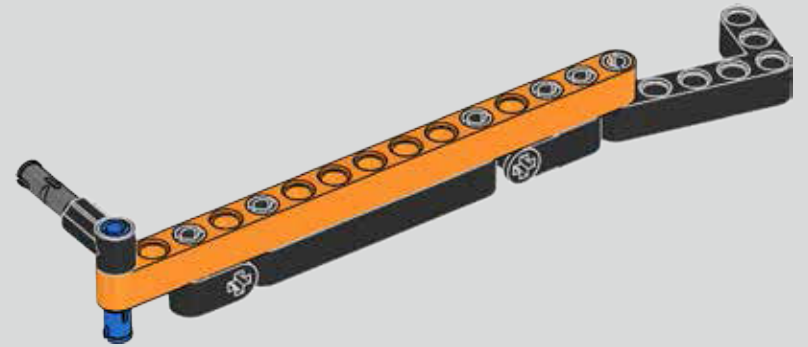



572

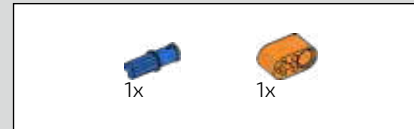
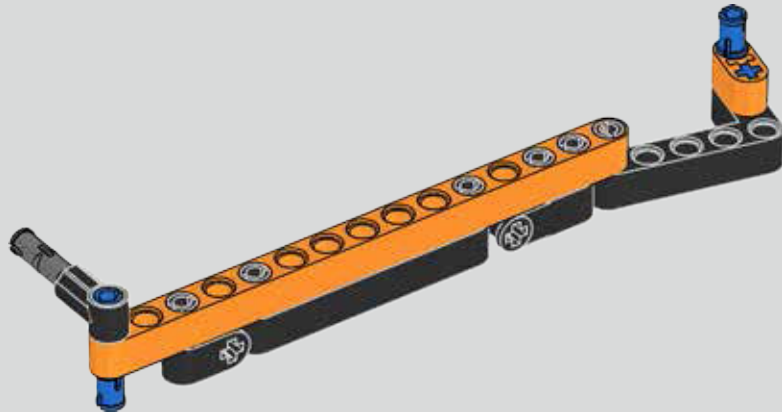
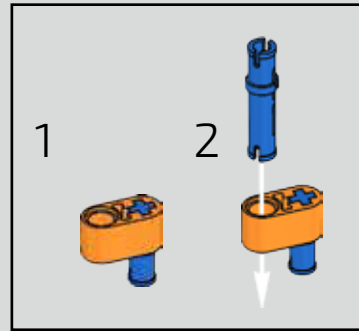

573

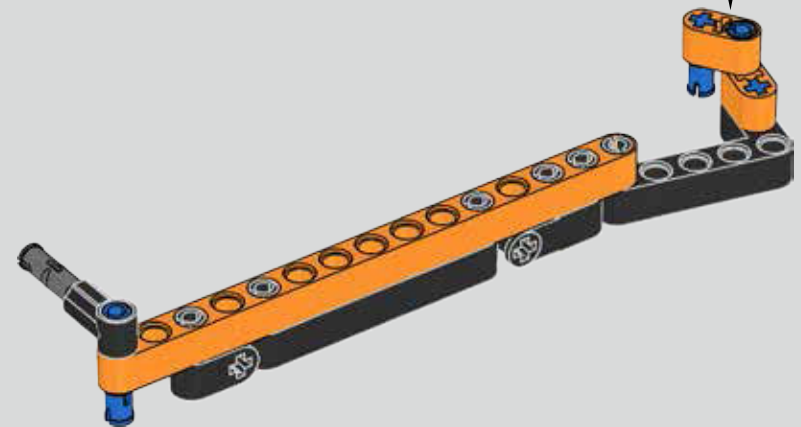
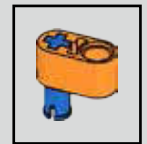

574

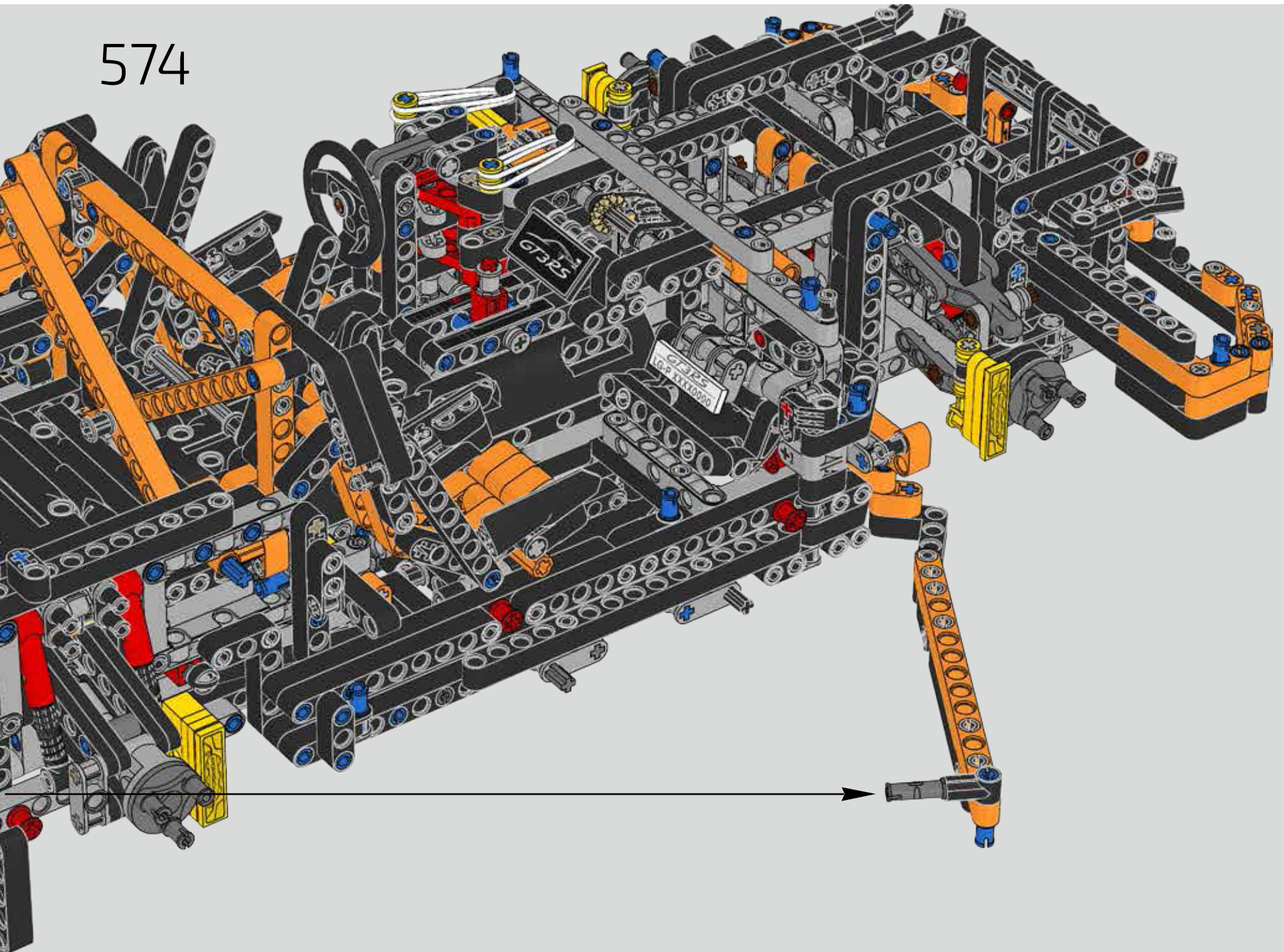

575

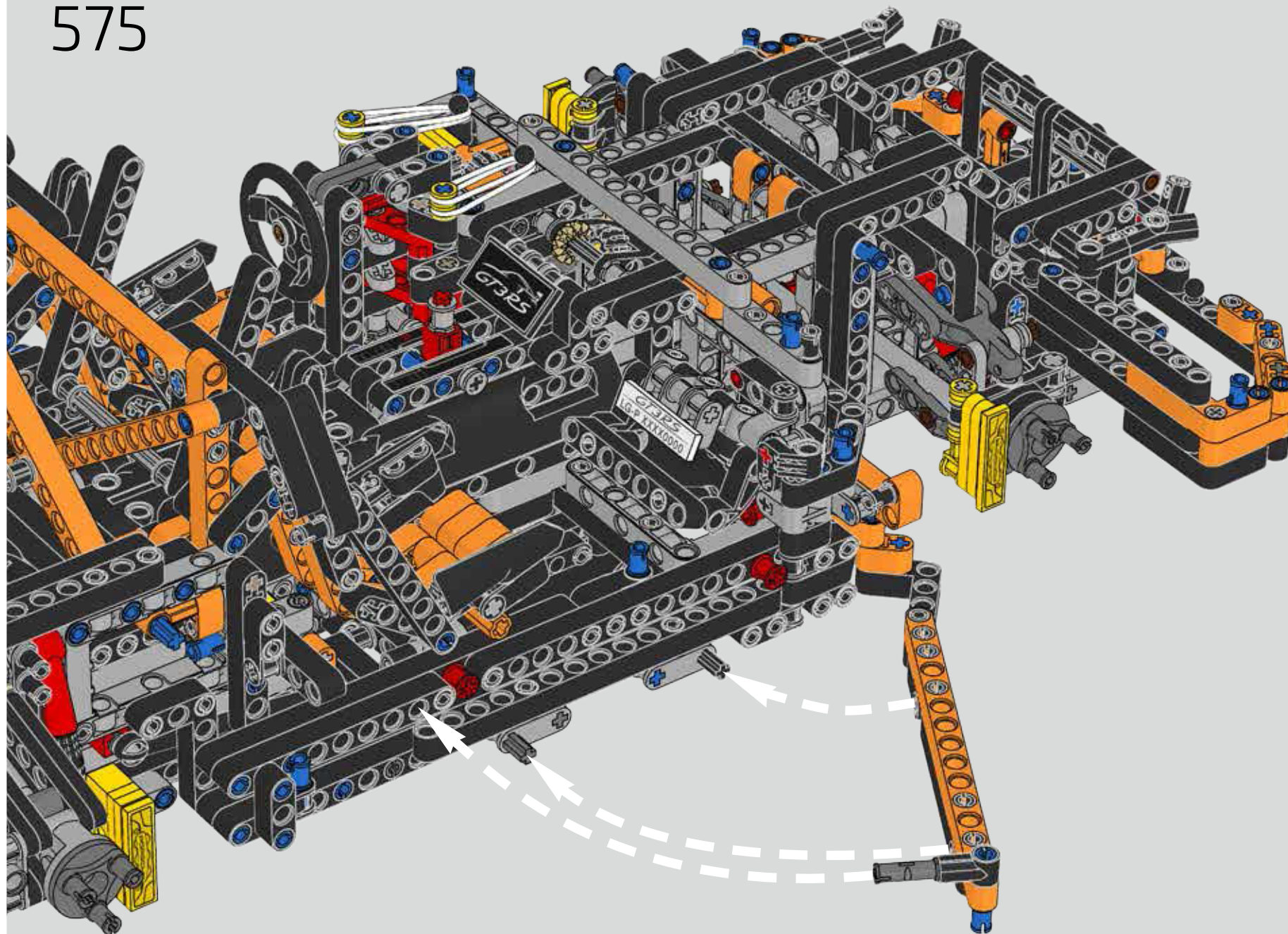

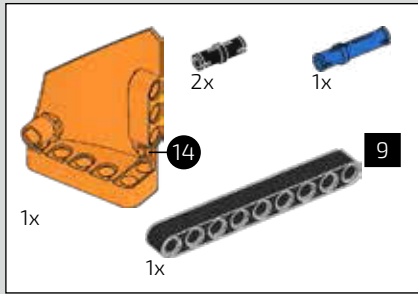

576

1

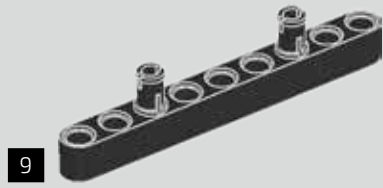

2

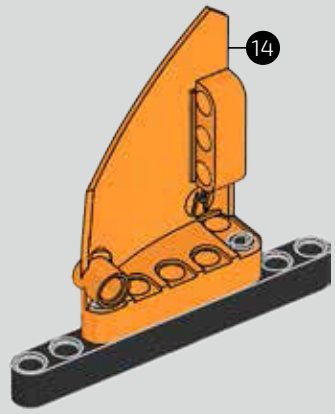

3

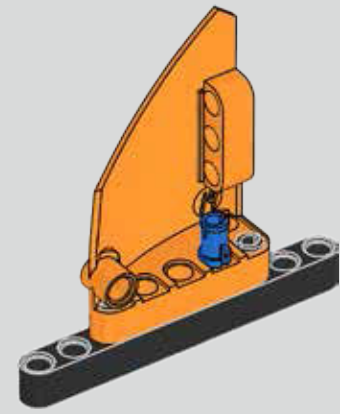

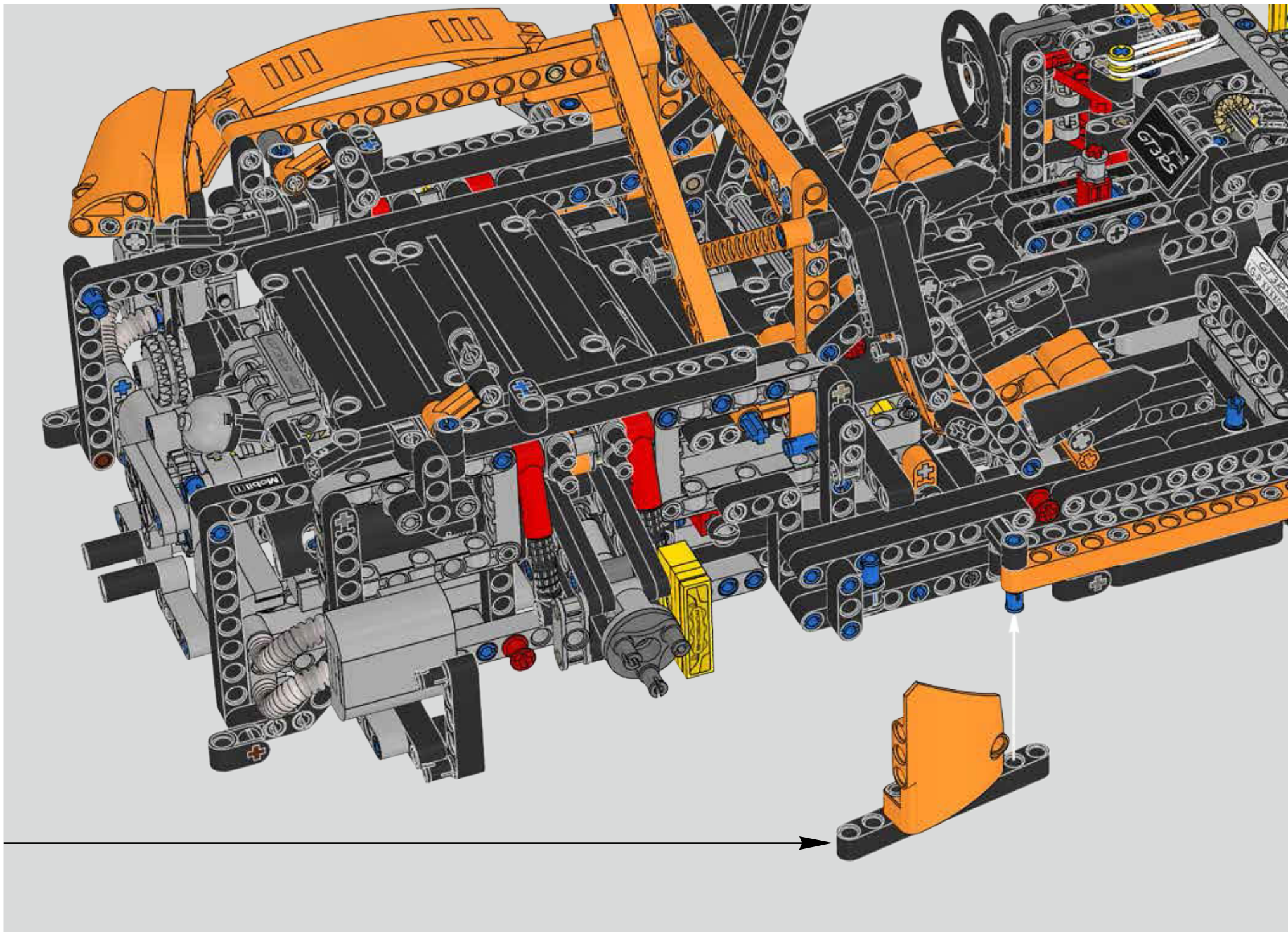

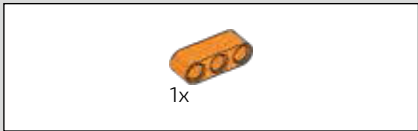

577

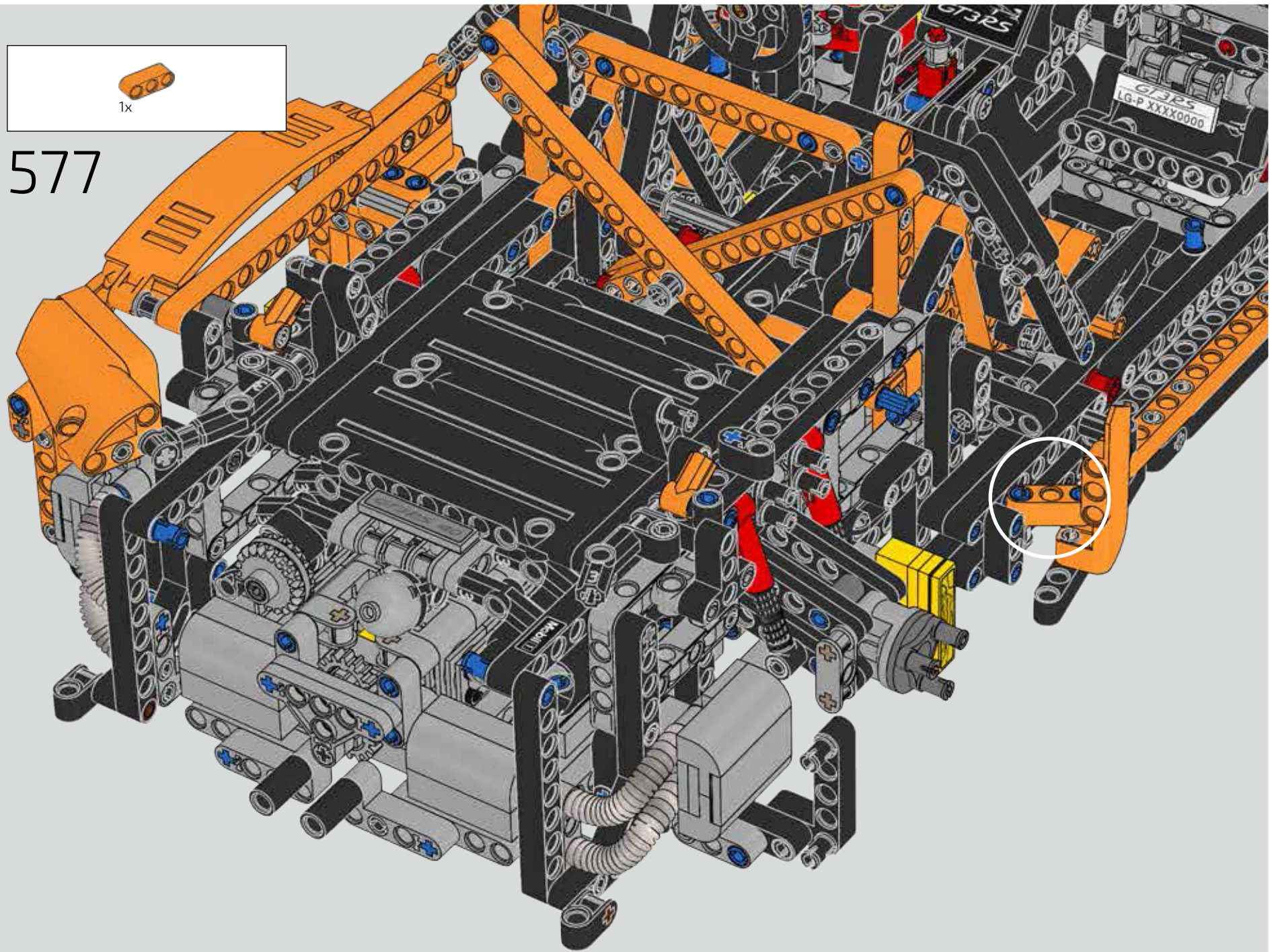



578

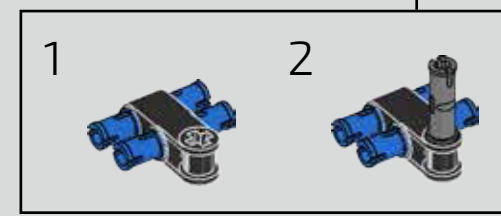
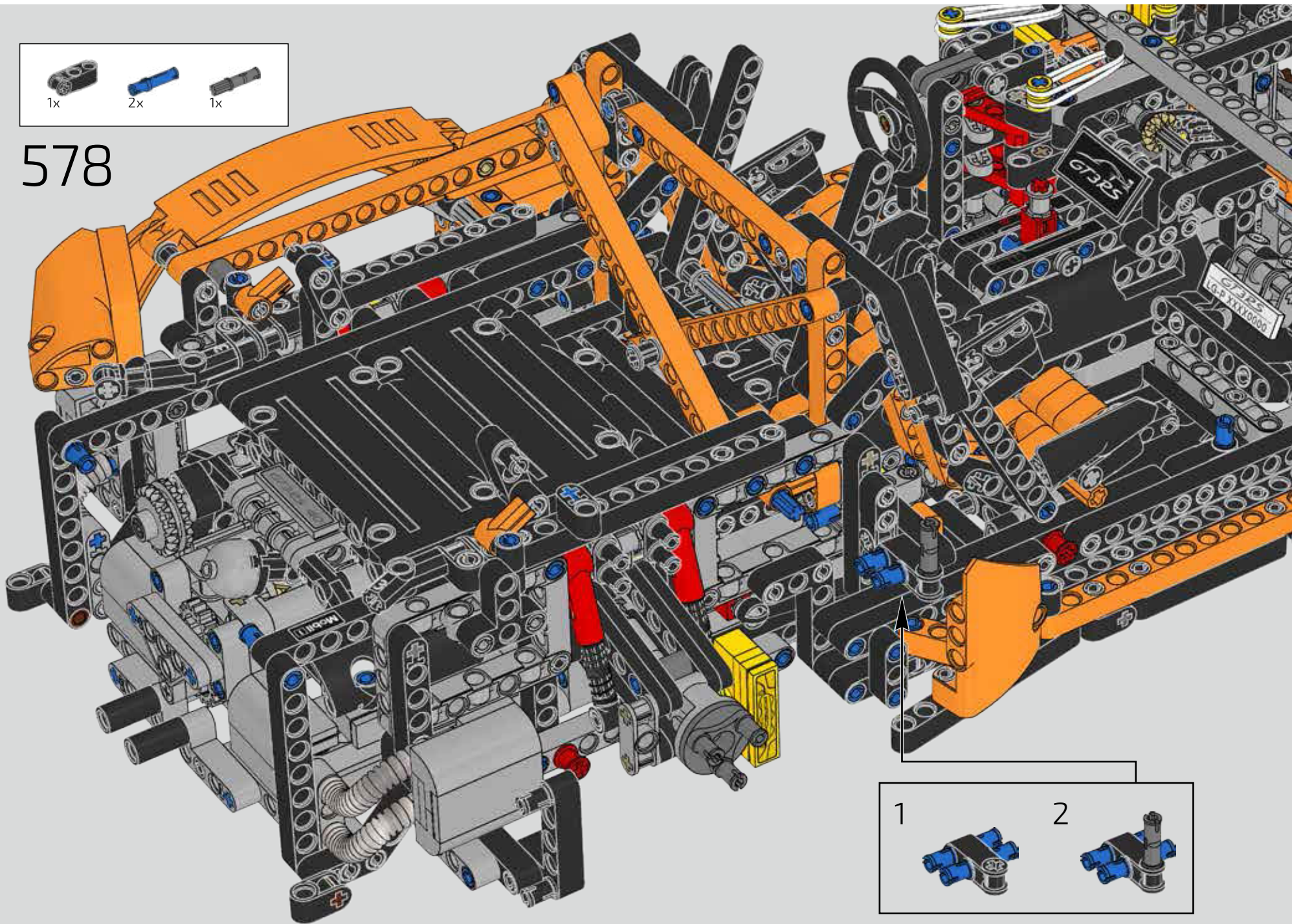

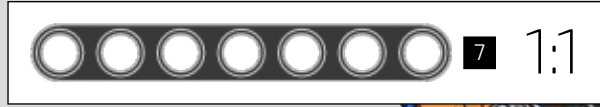
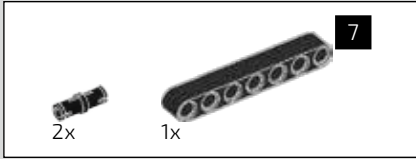

579

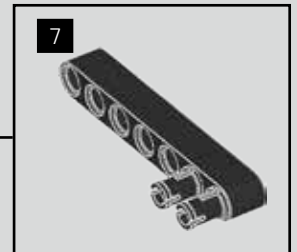
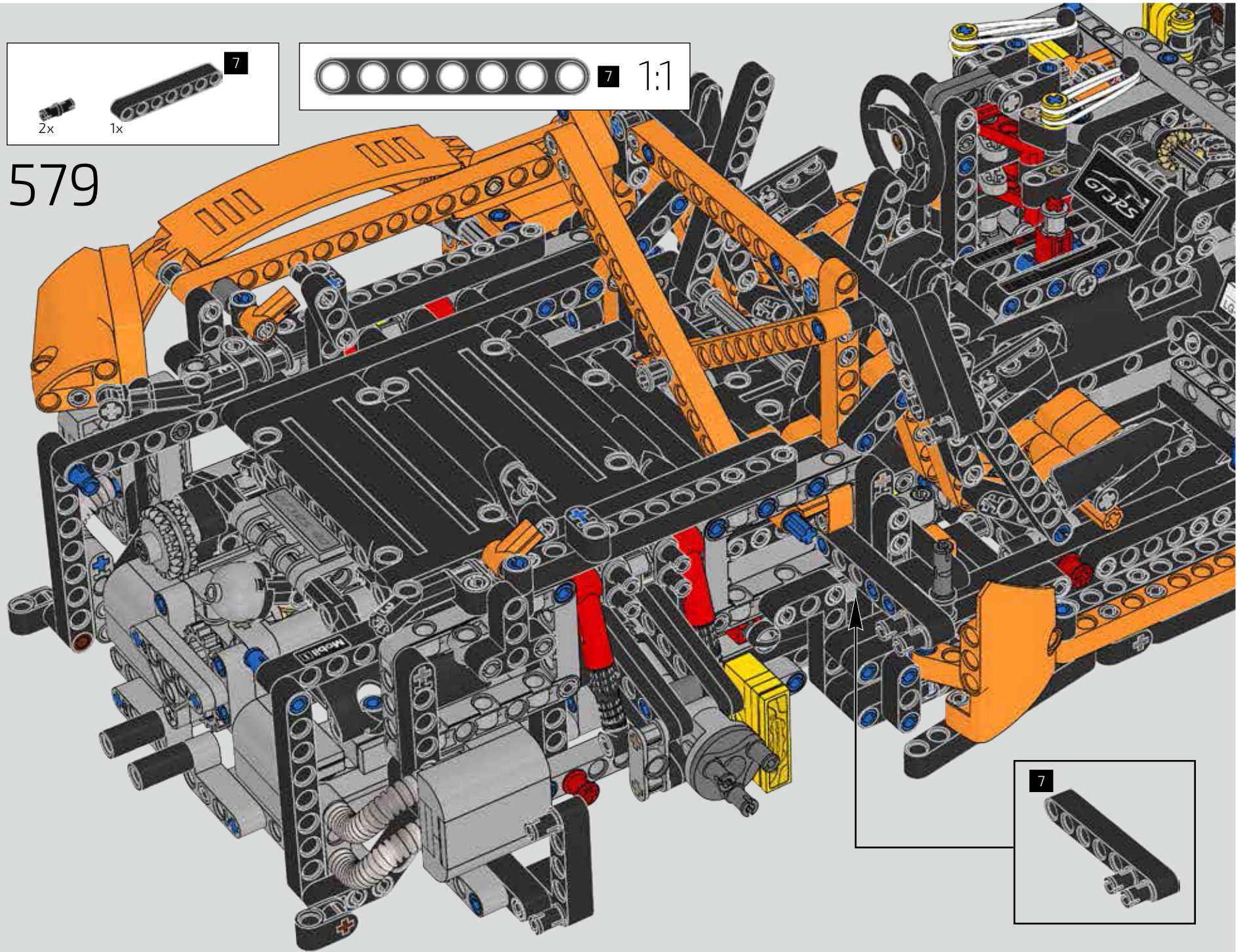

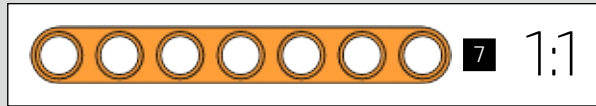
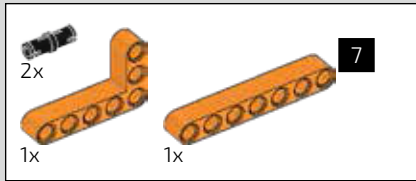

580

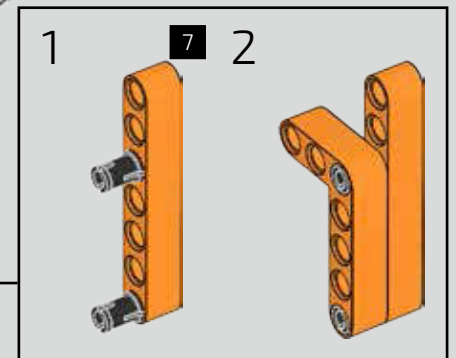
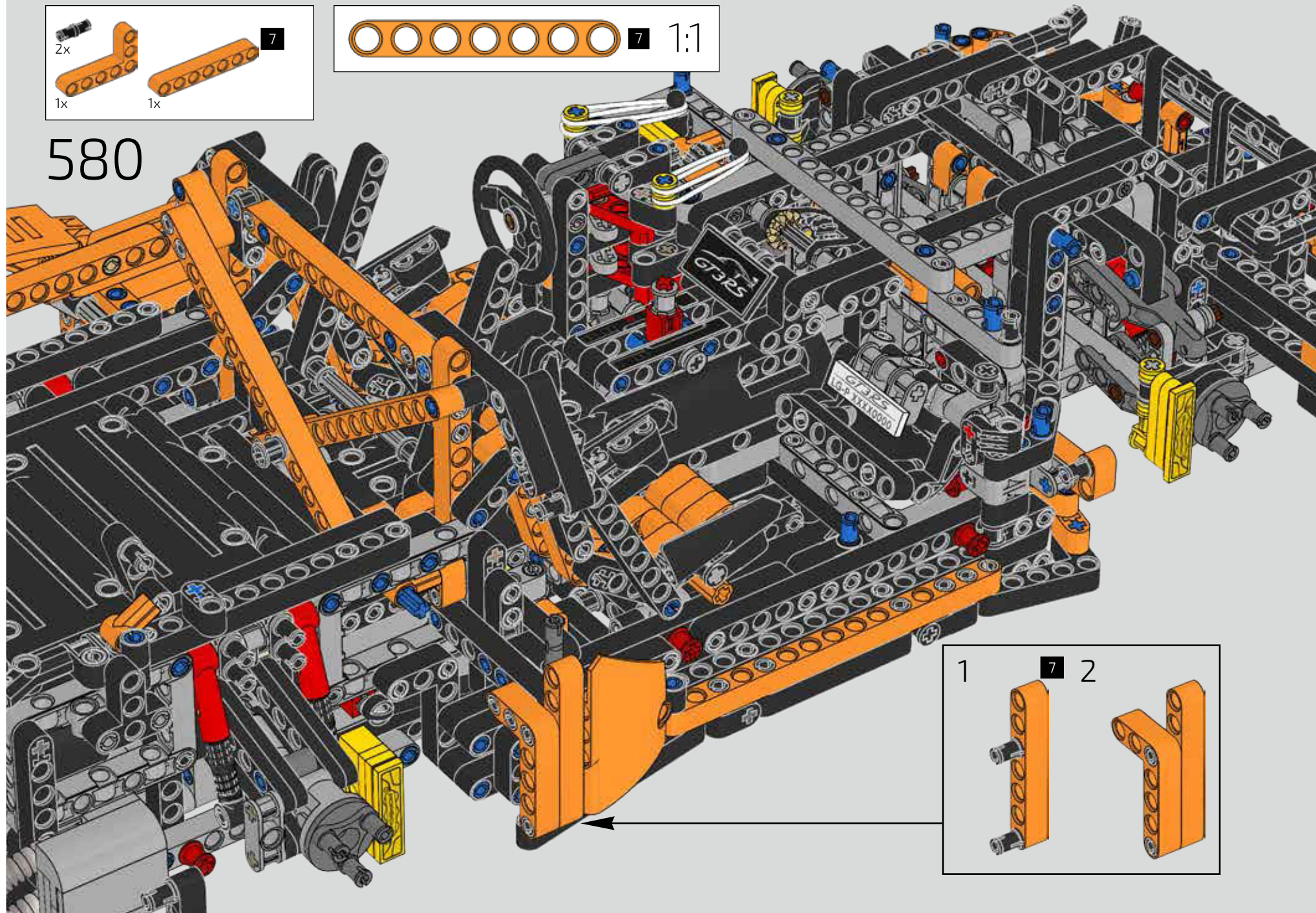

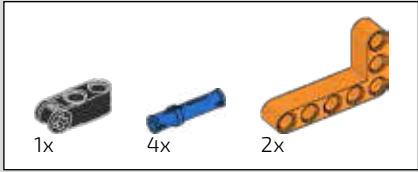

581

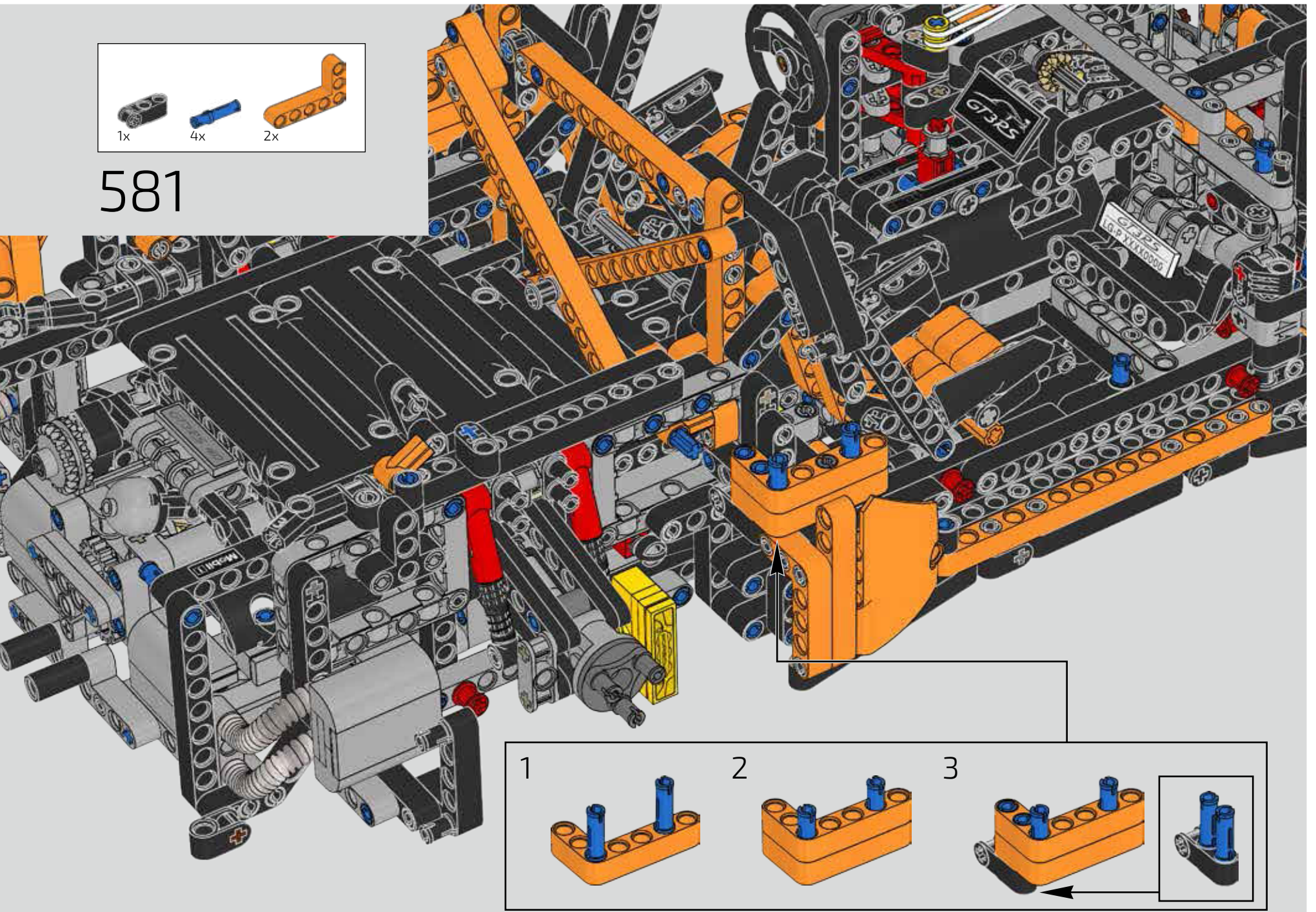

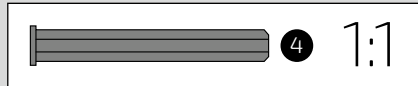
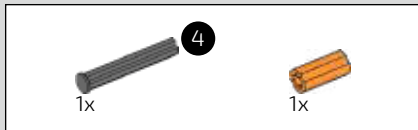

582

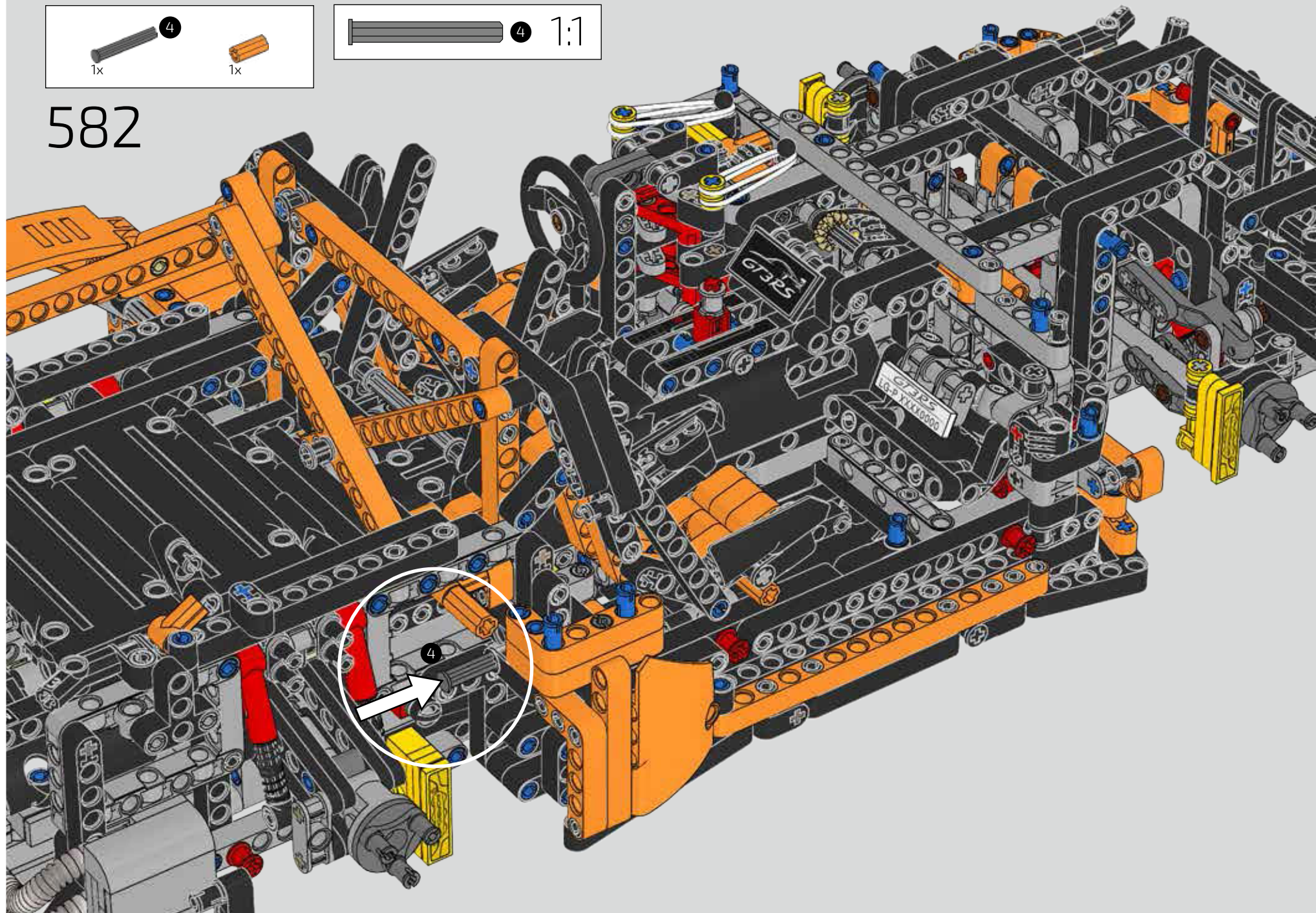

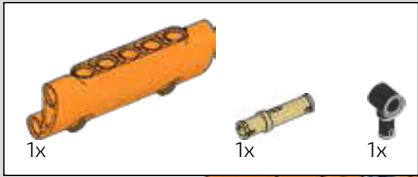

583

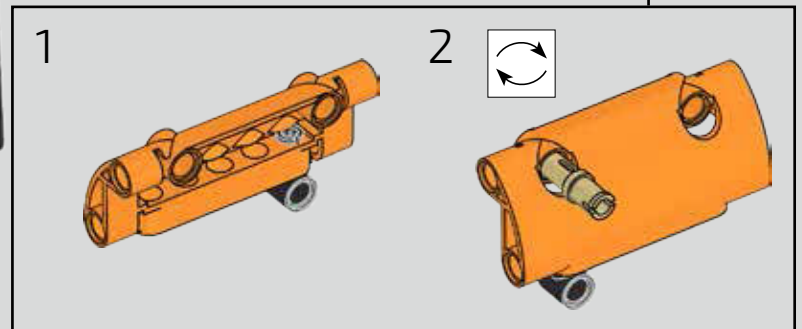
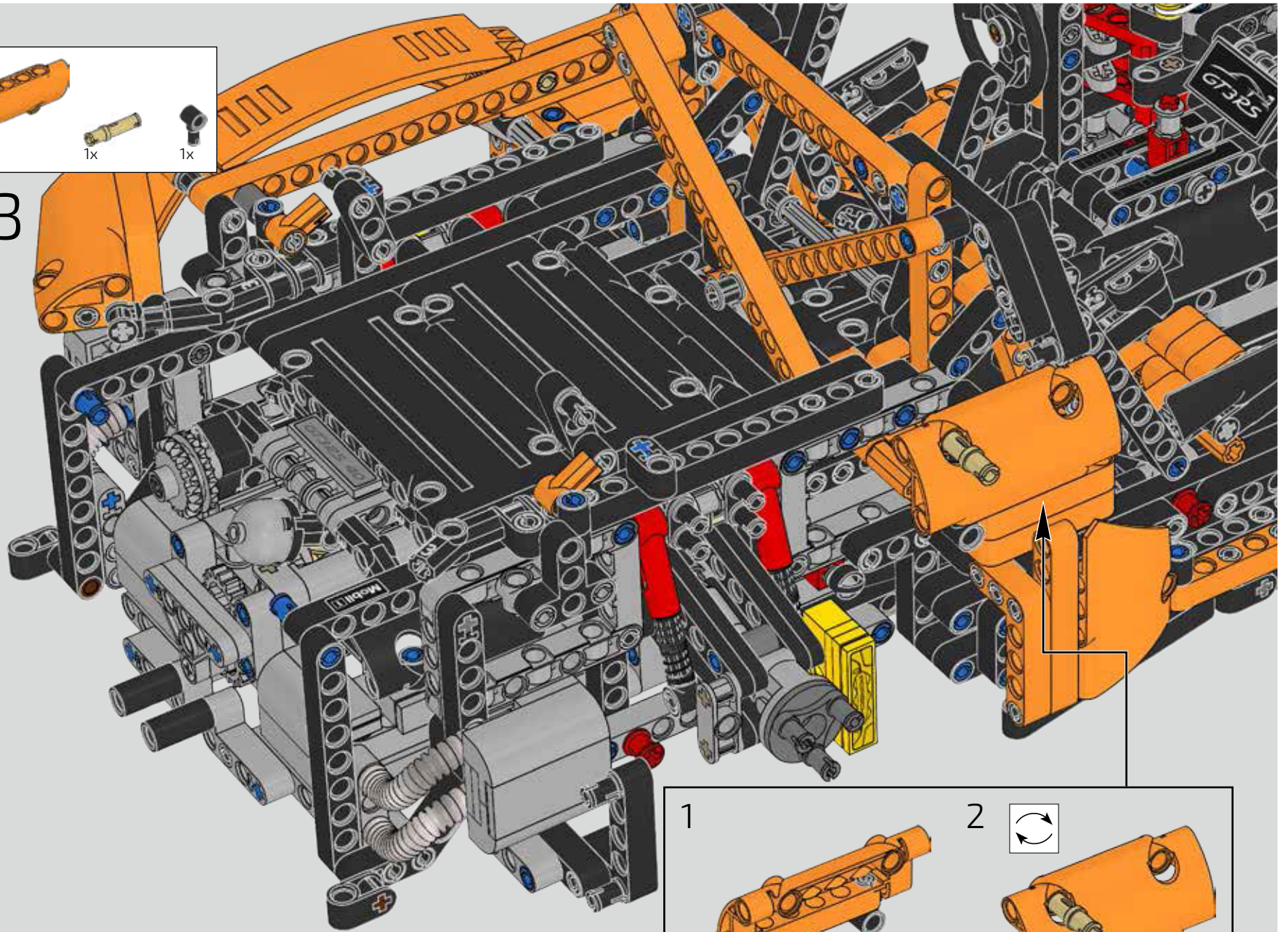

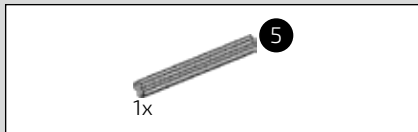

584

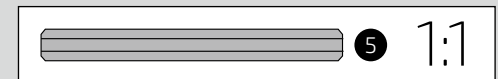
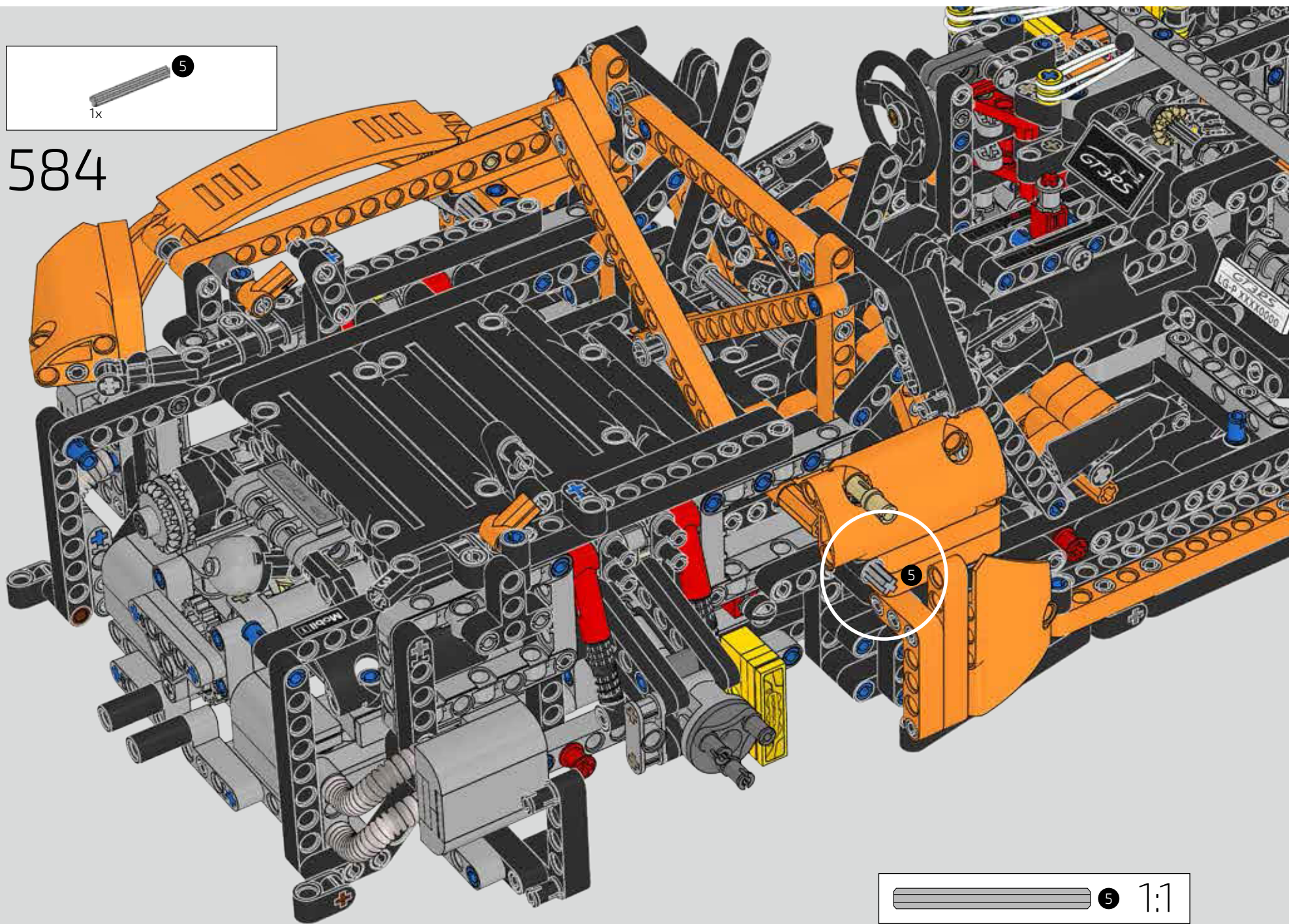

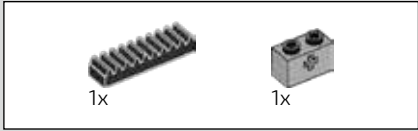

585

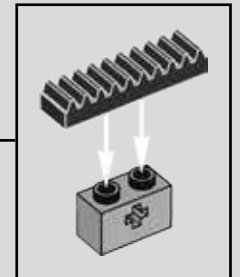
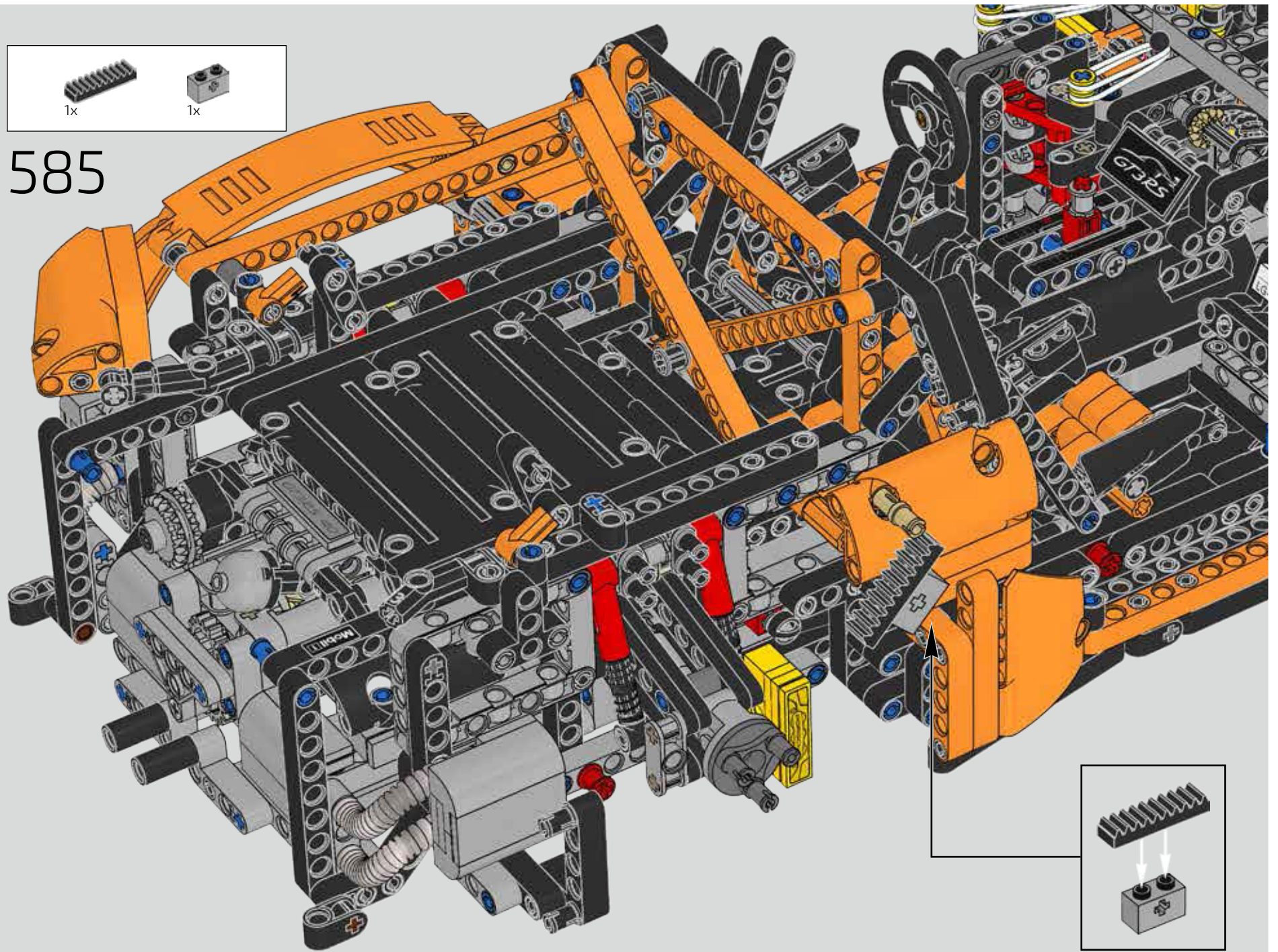

586

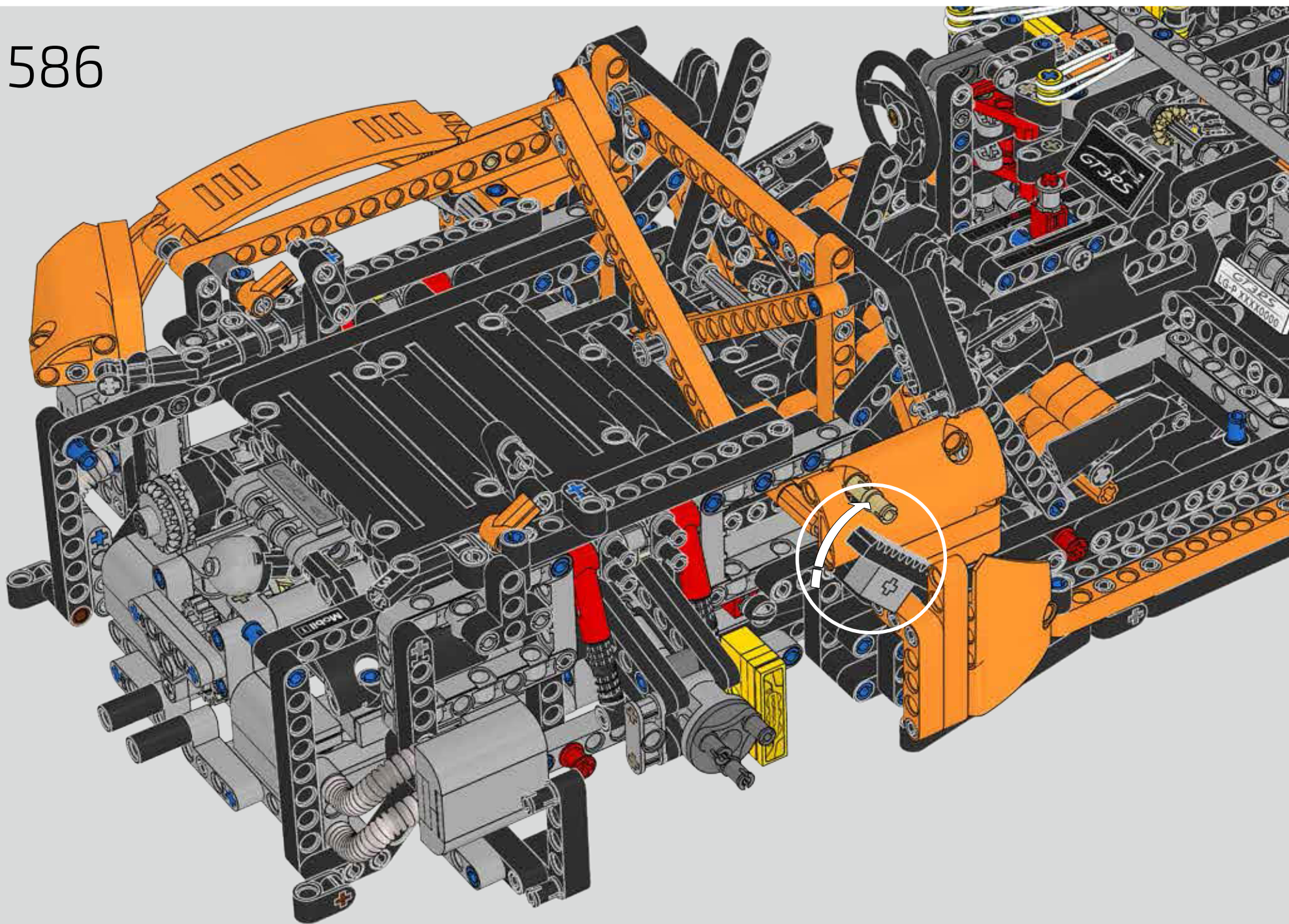

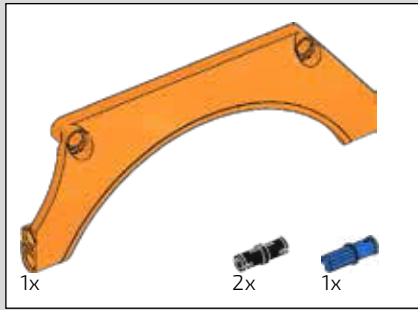

587

1

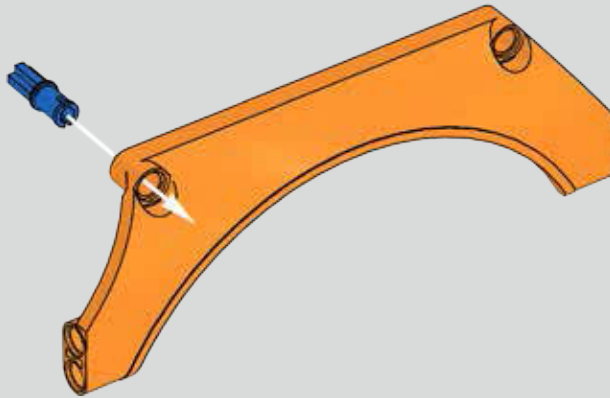

2

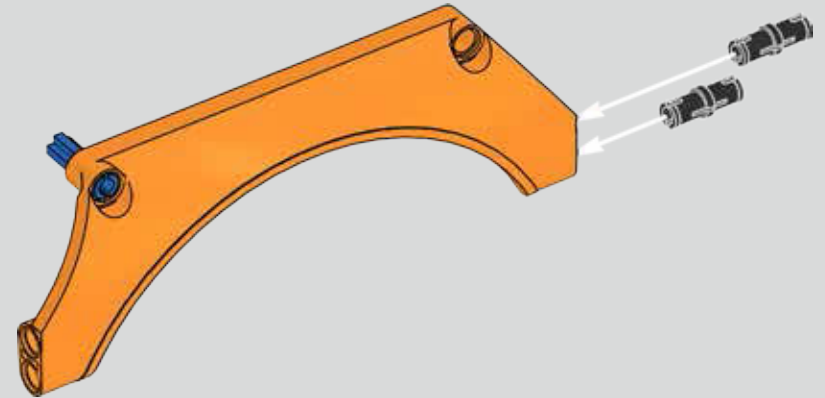

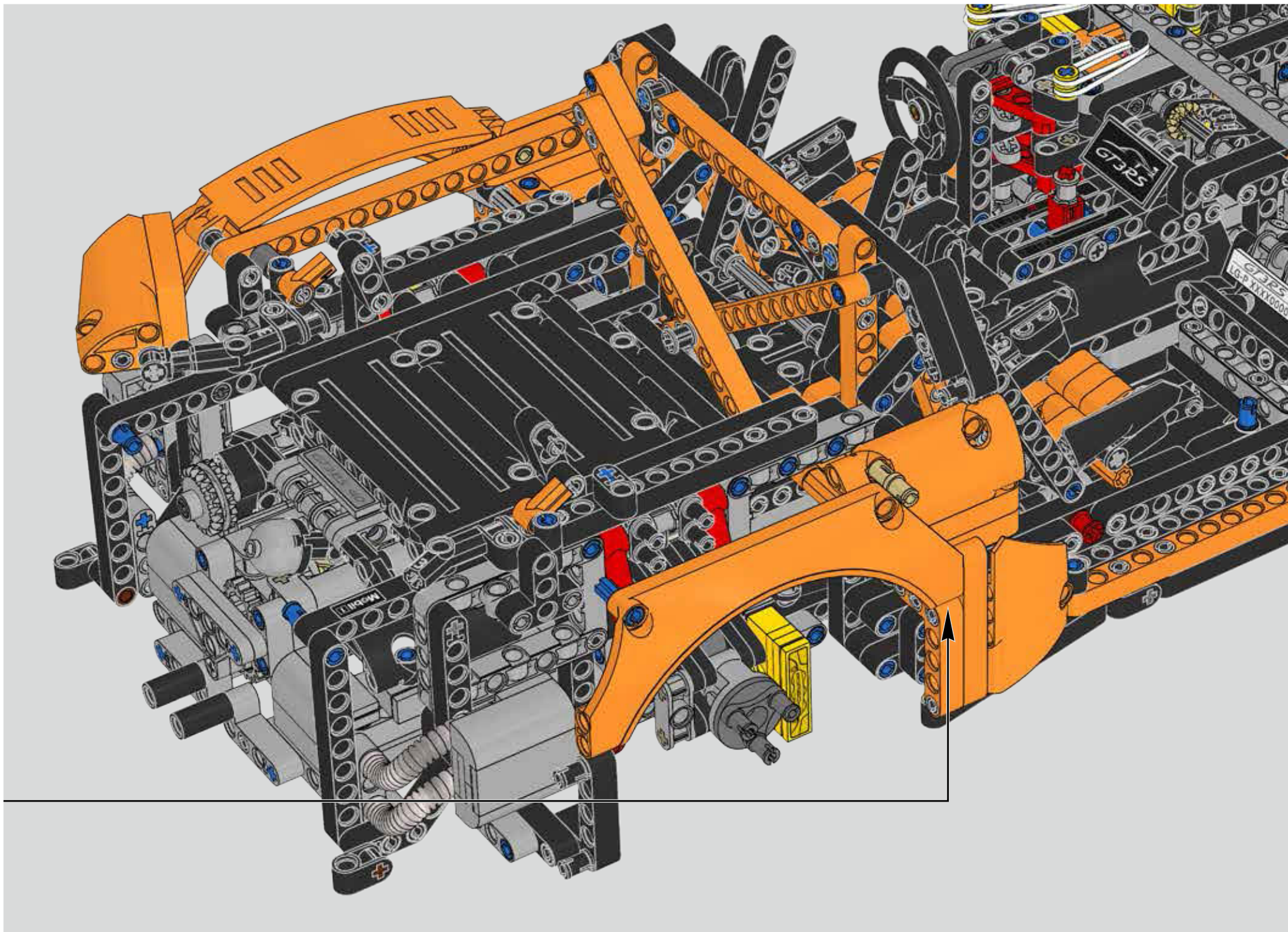

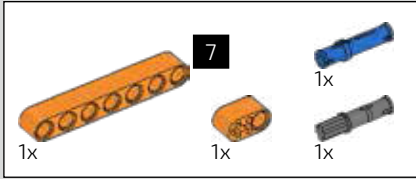

588

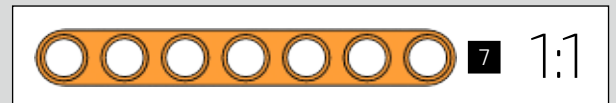
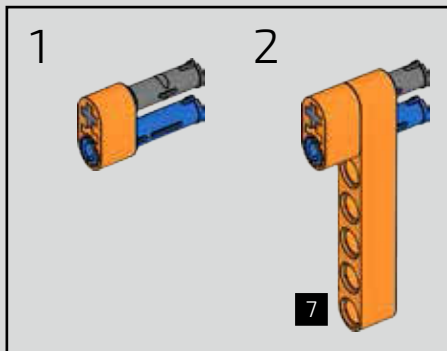
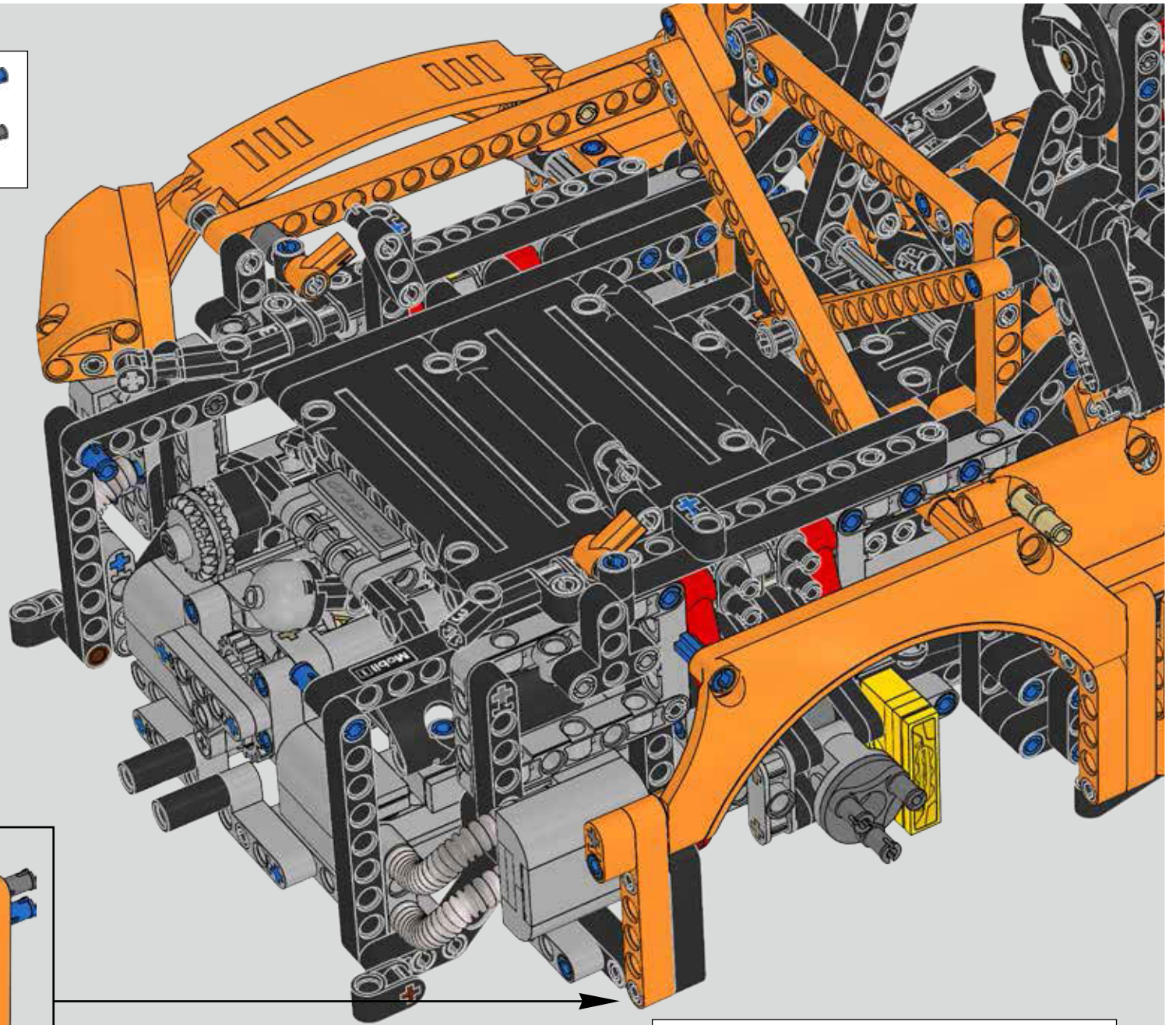

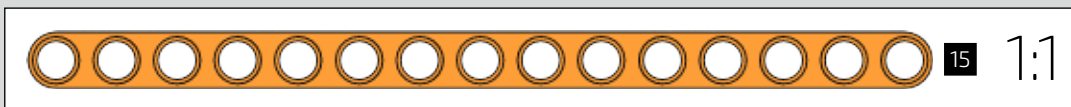
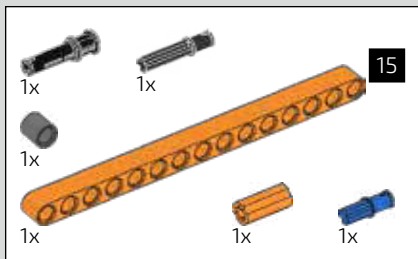

589

1

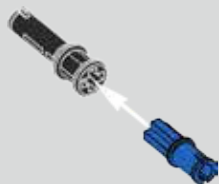

2

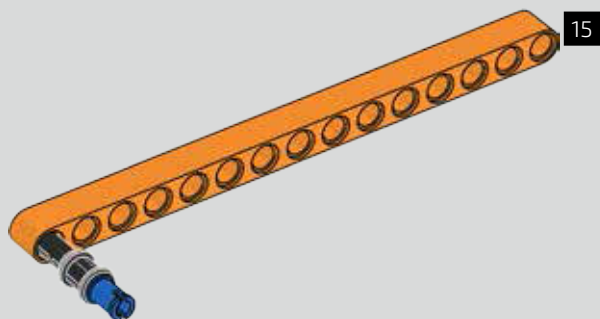

3

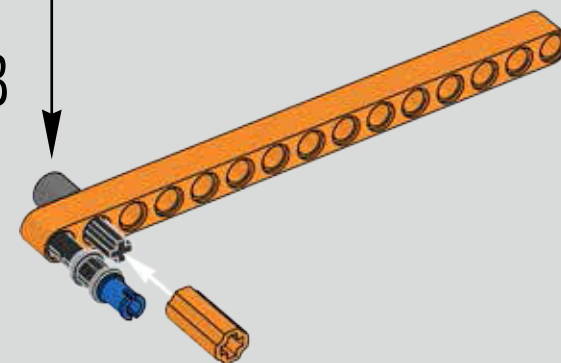
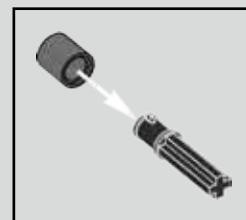

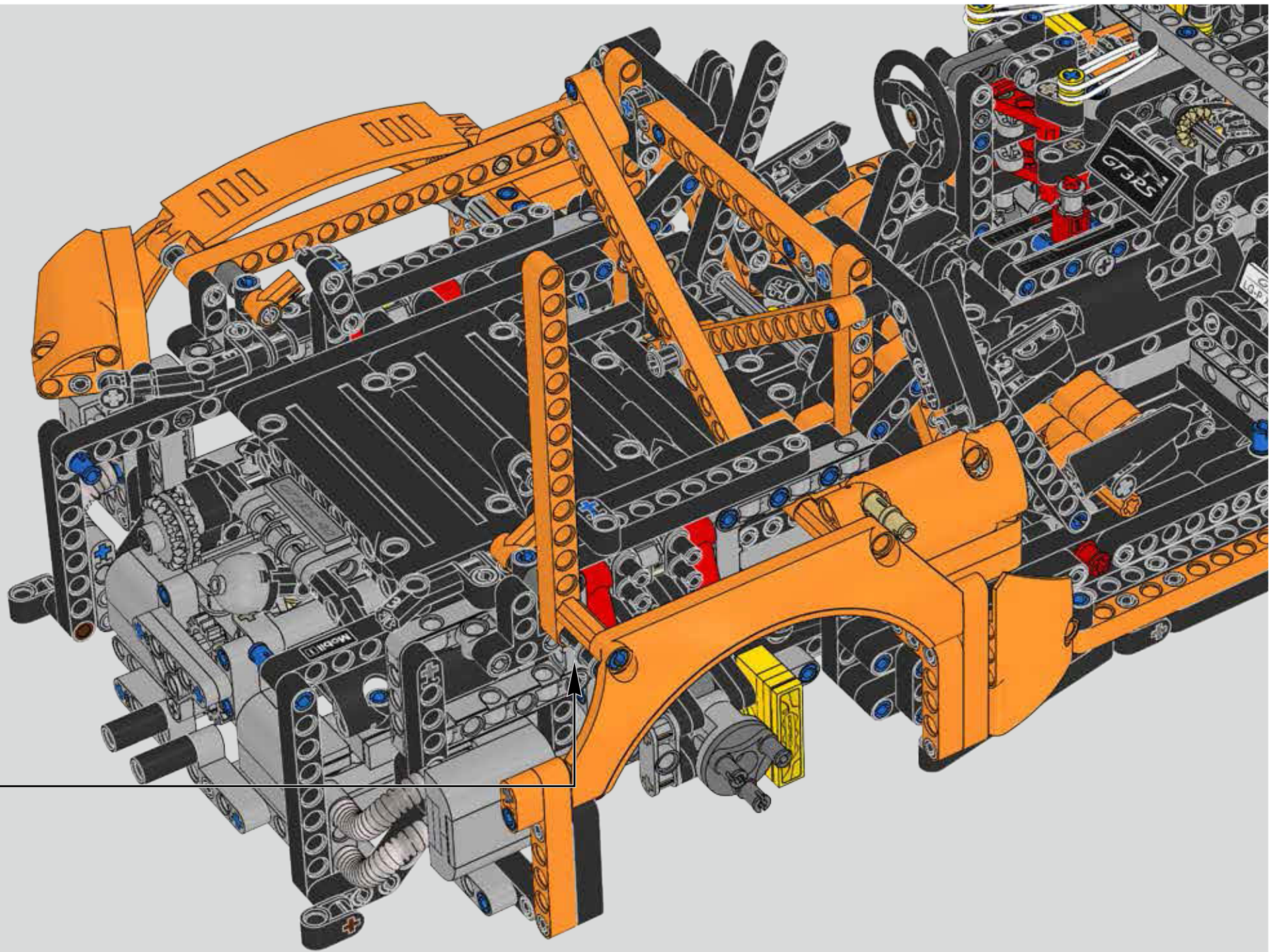

590

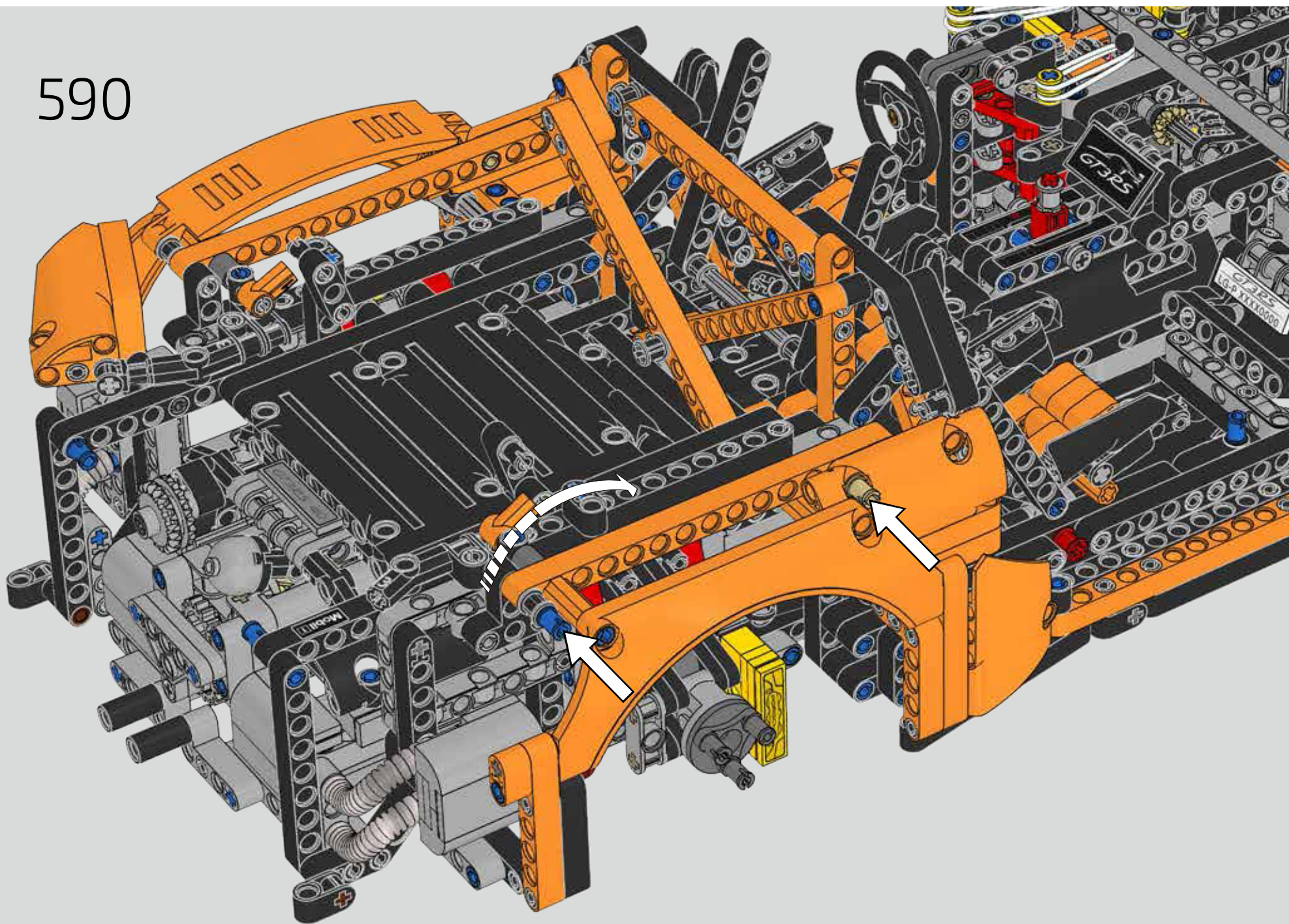

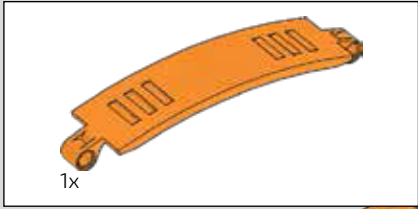

591

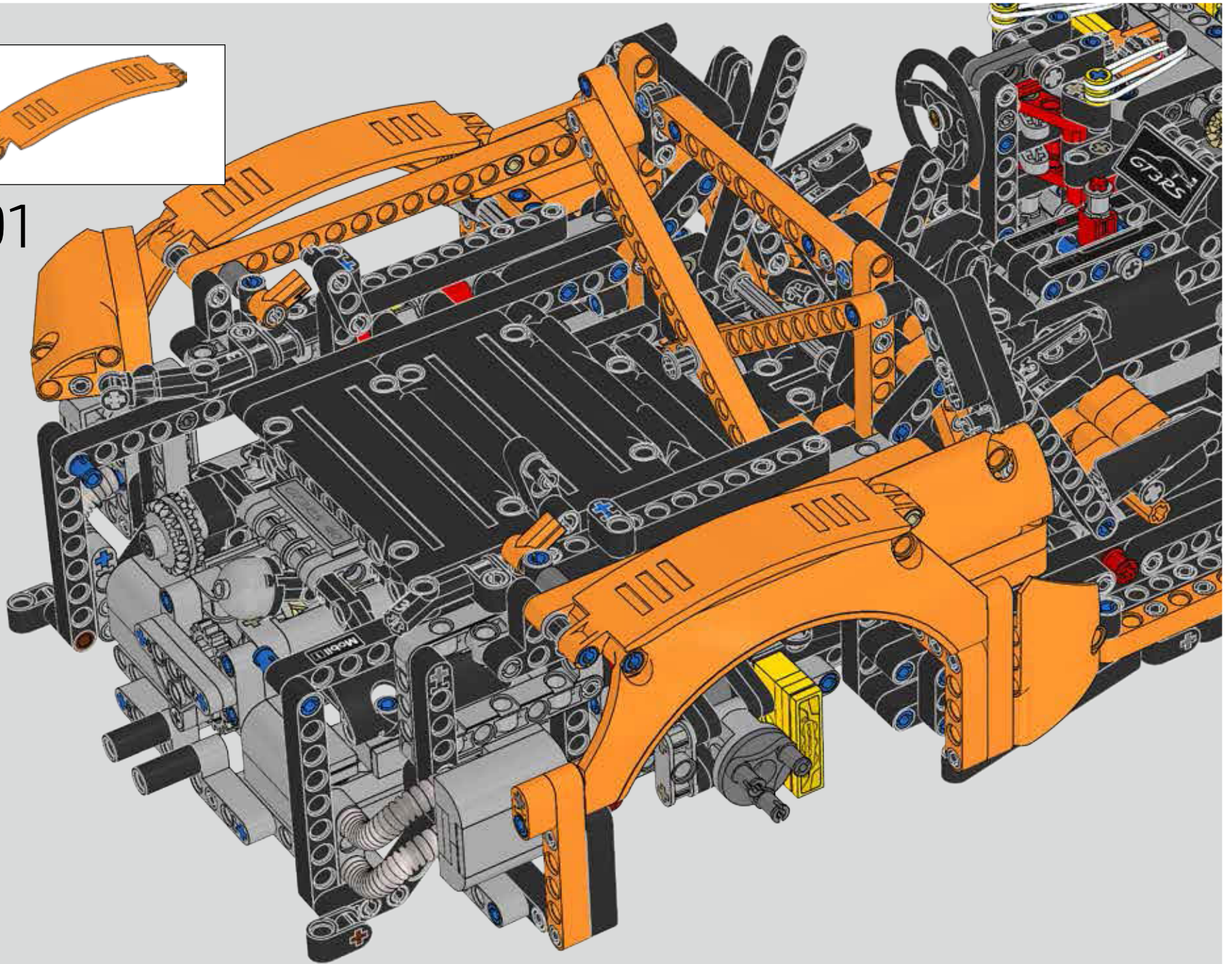

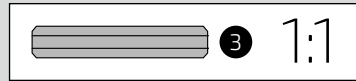
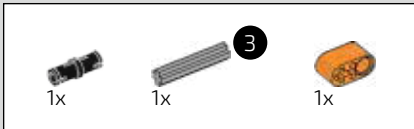

592

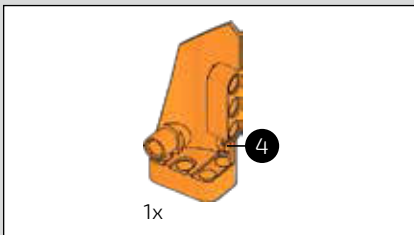
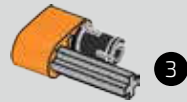

593

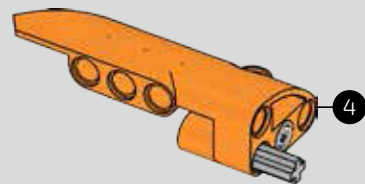

594

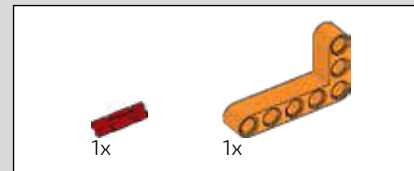
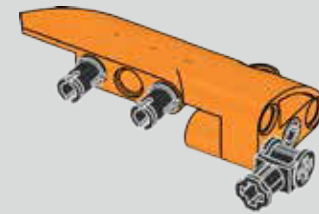

595

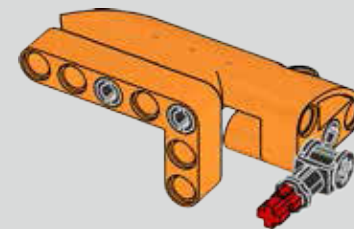

596

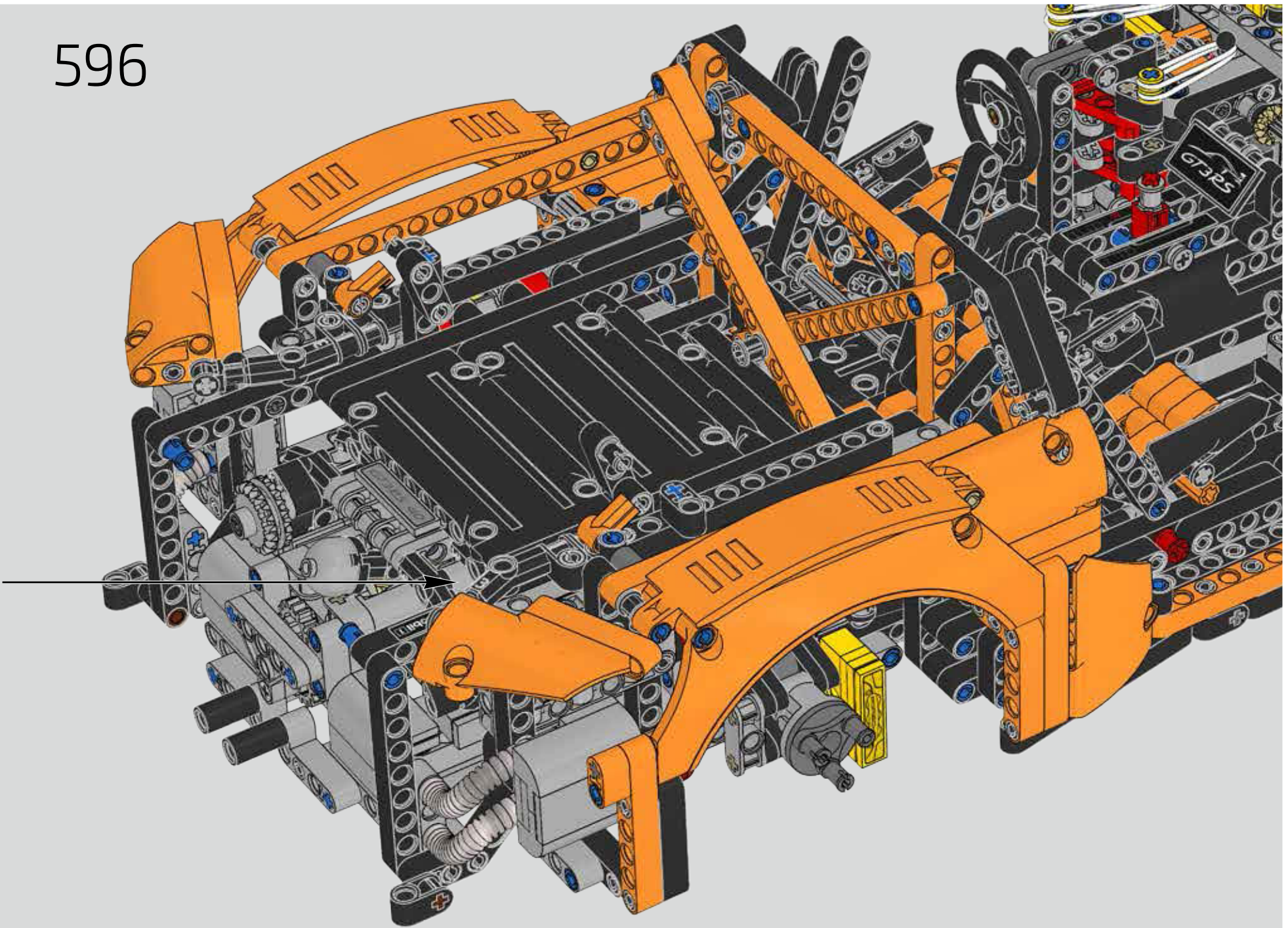

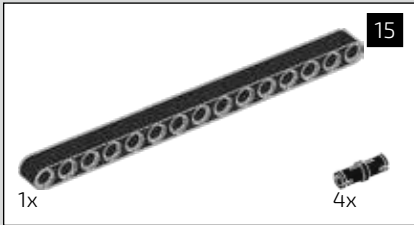
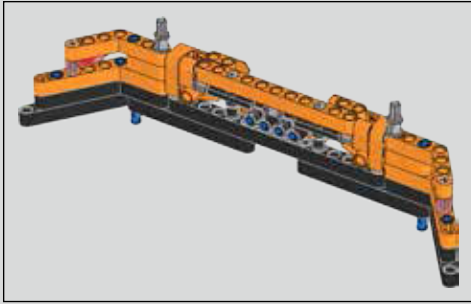

597

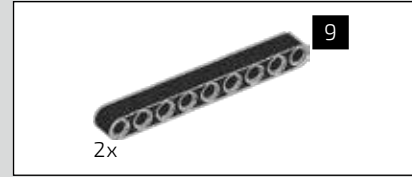

598

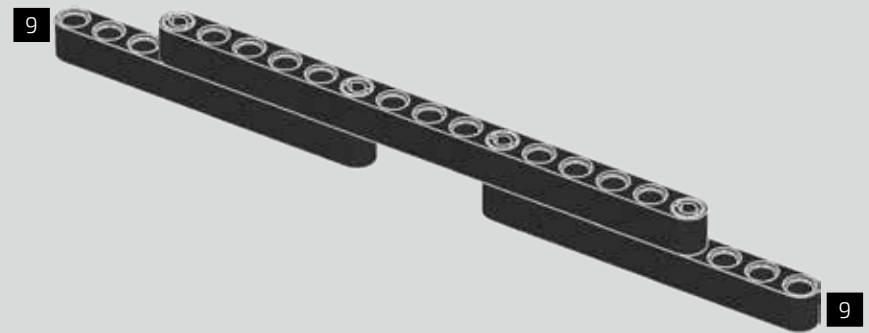

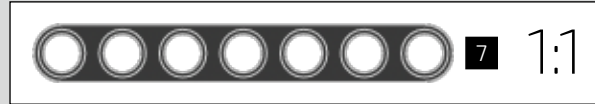
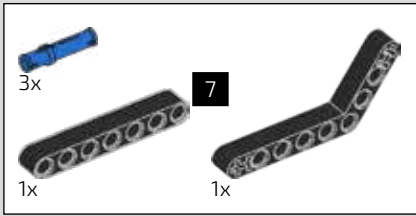

599

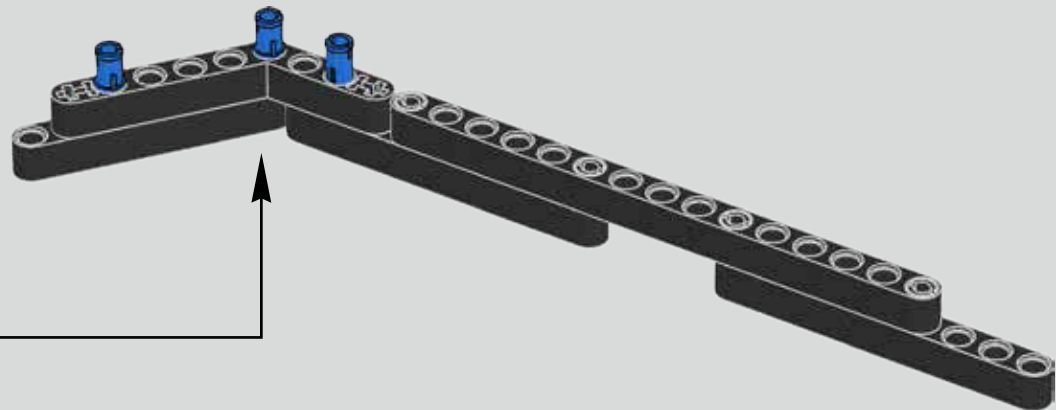
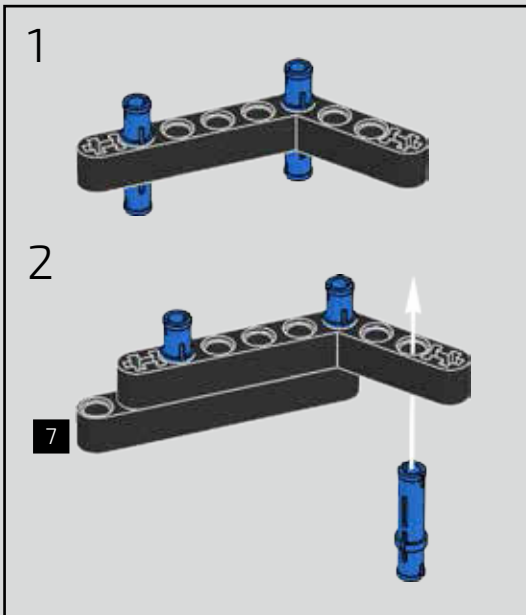

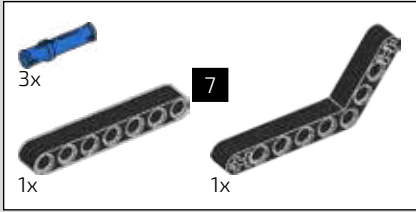

600

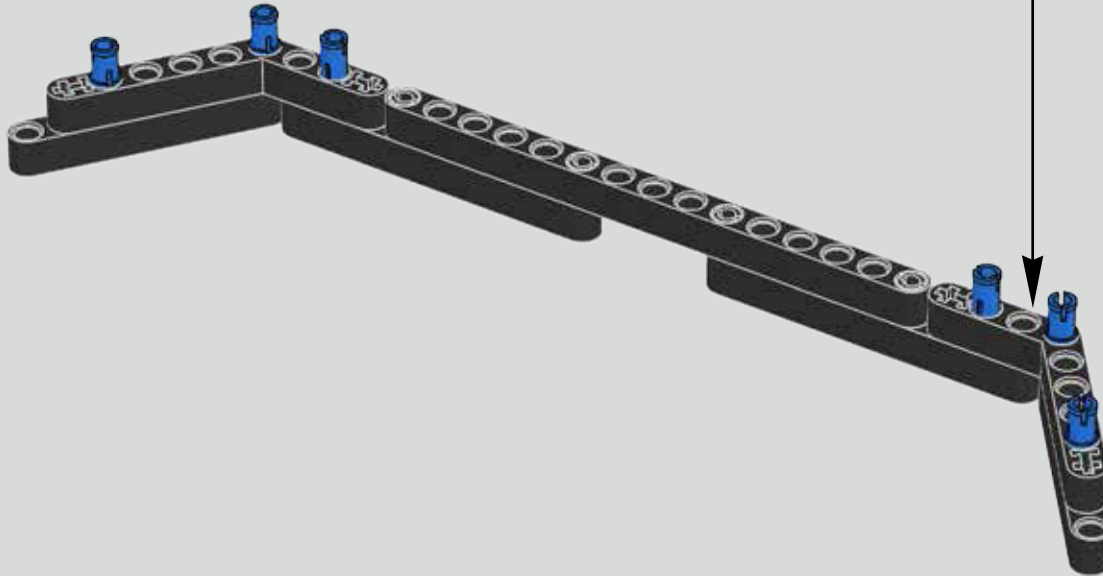
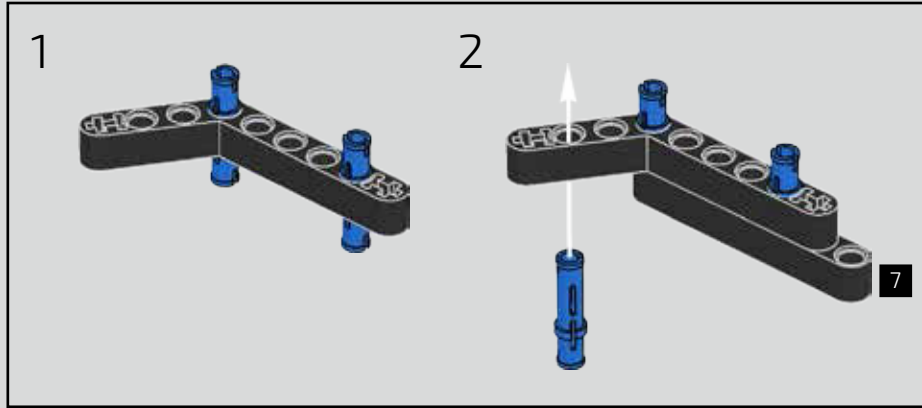

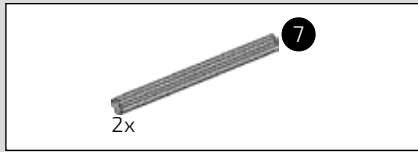

601

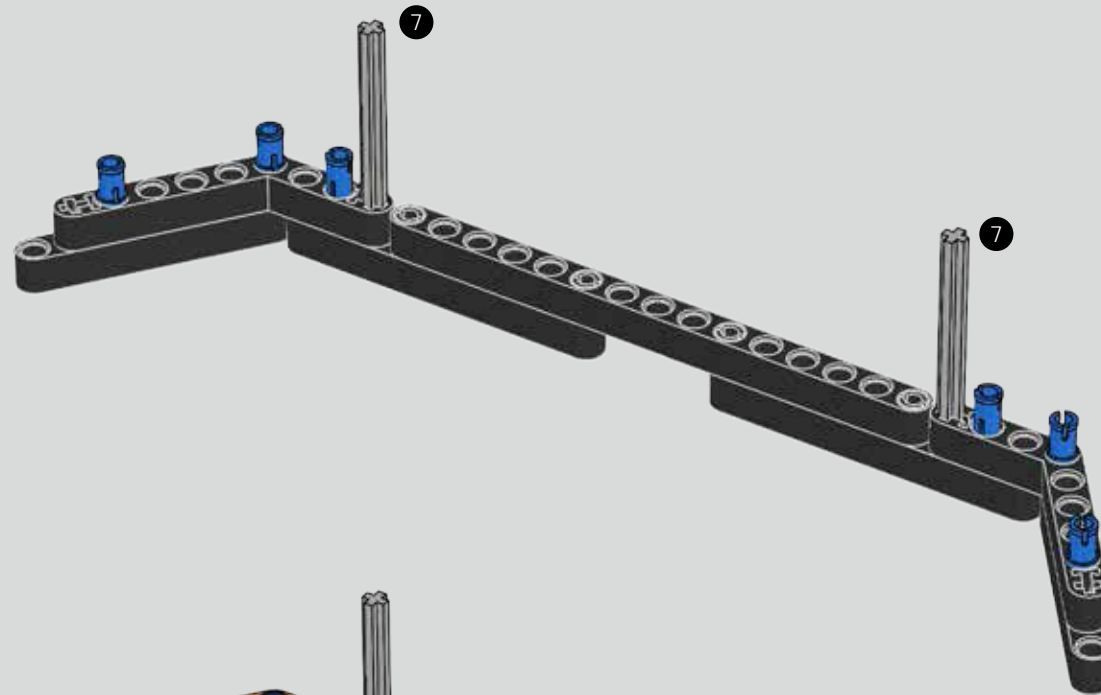

602

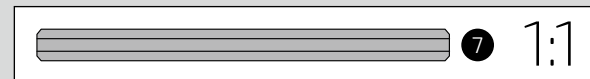
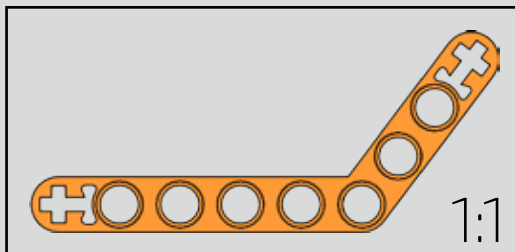
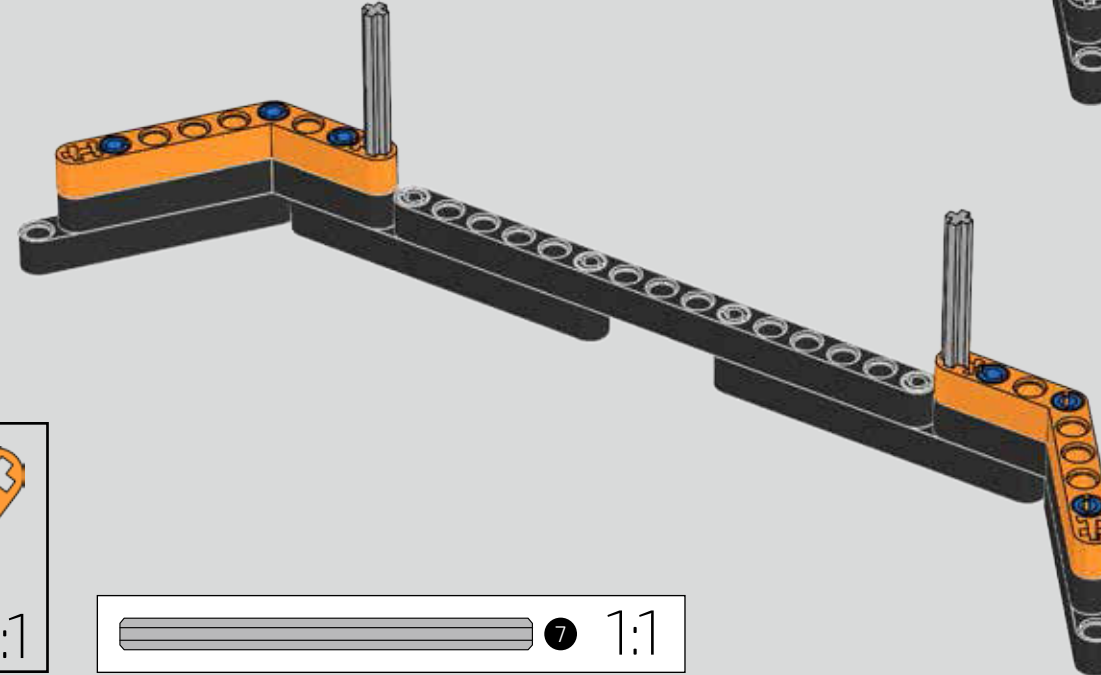



603

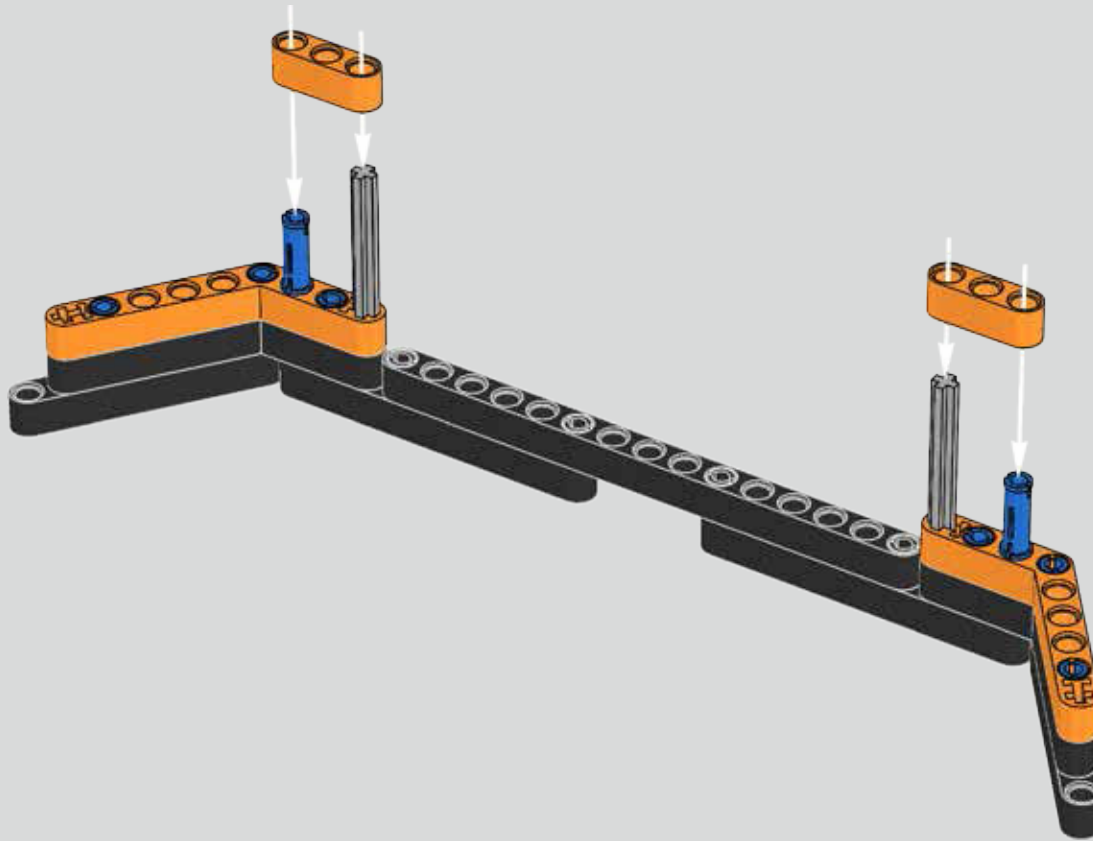

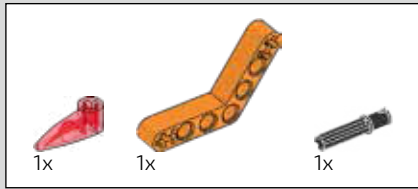

604

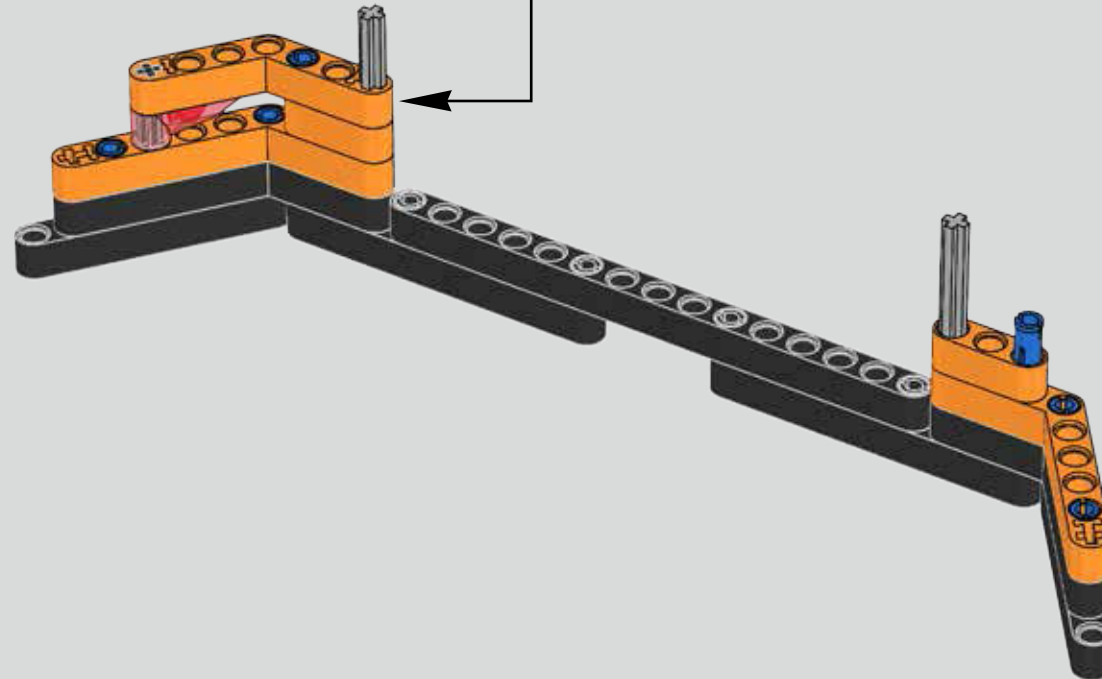
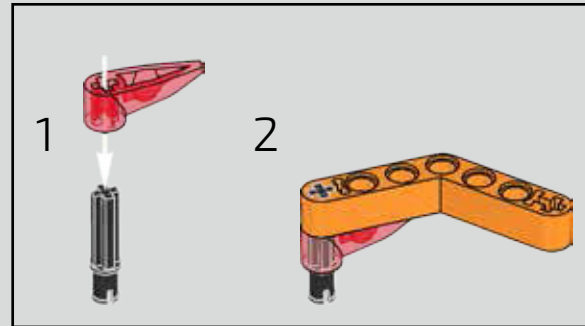

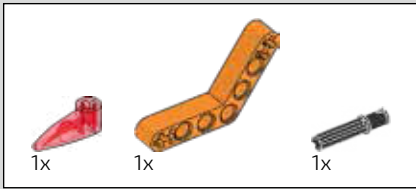

605

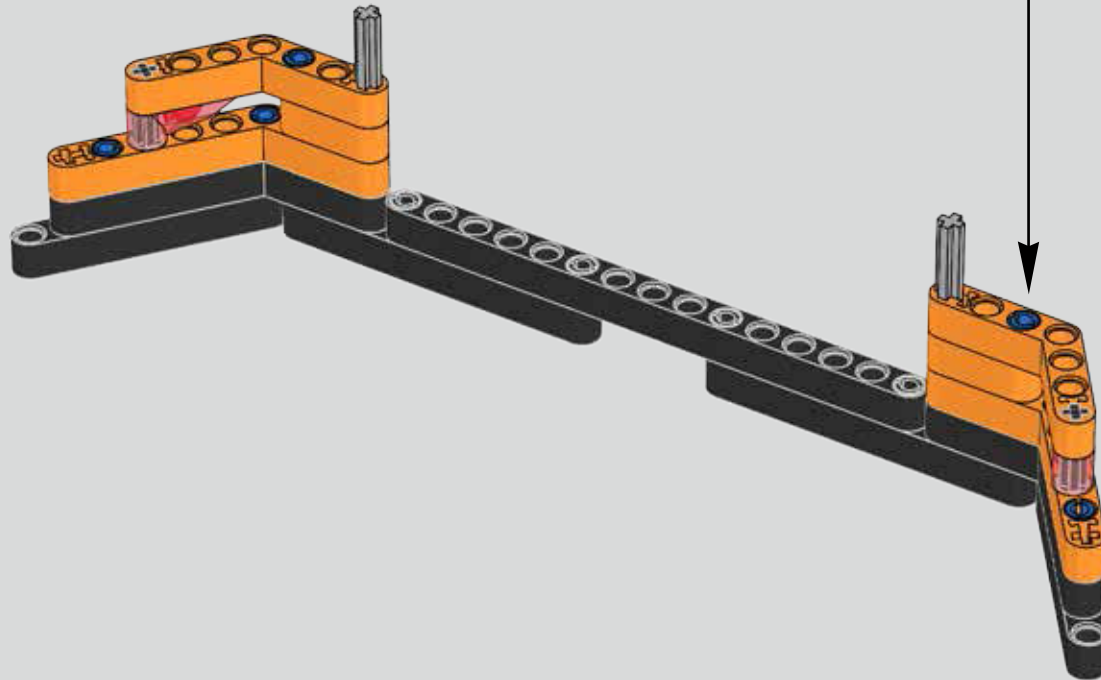
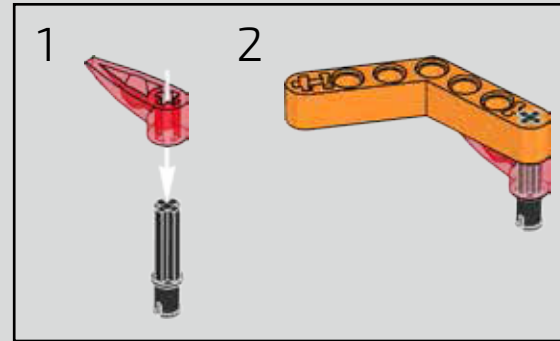

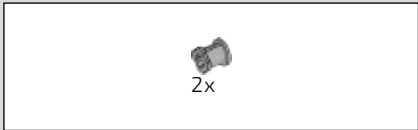

606

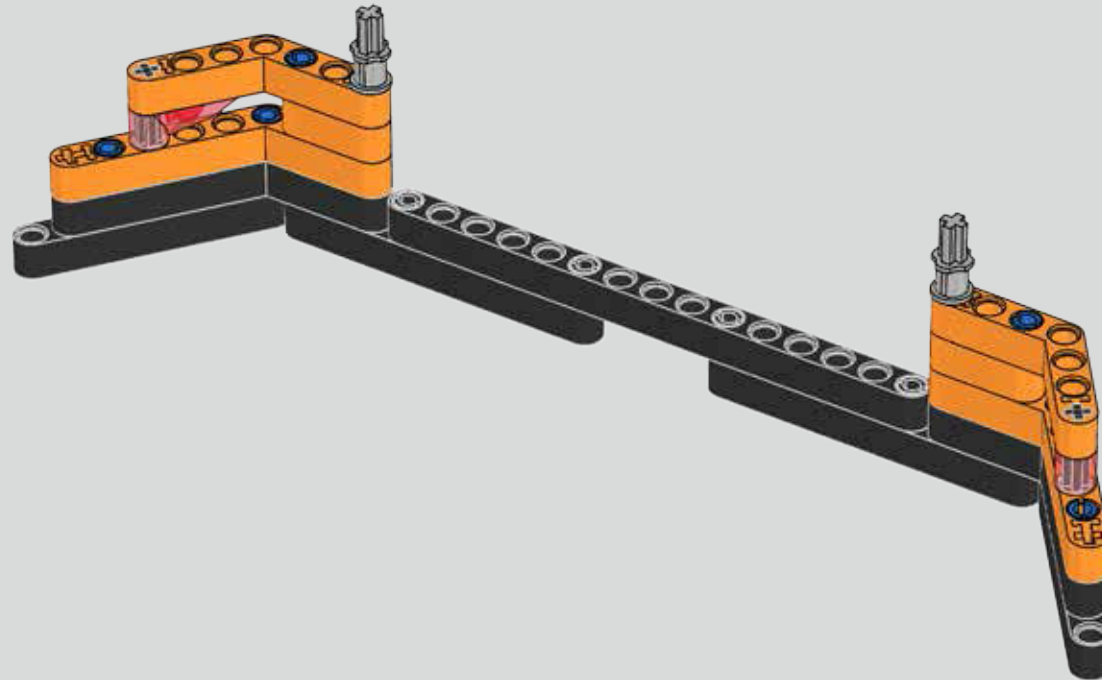

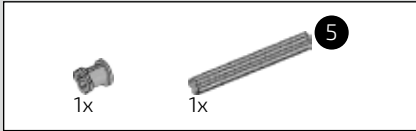
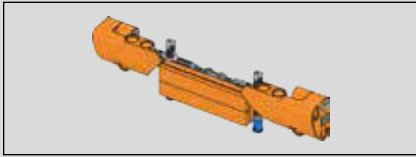

607

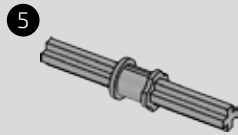

608

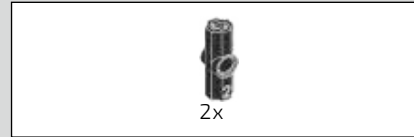
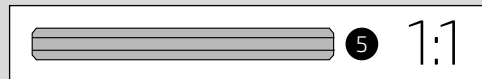

609



610

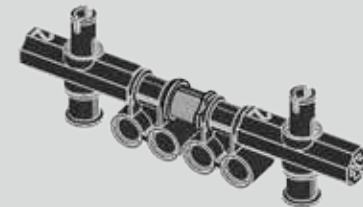

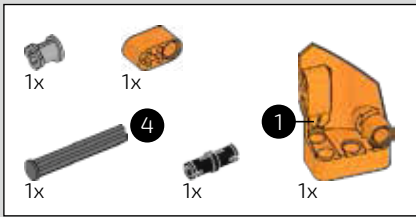

611

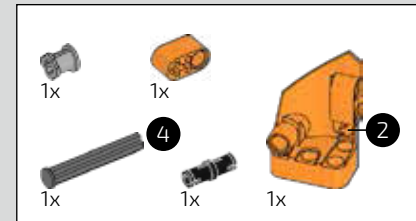
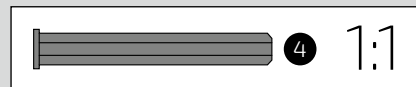
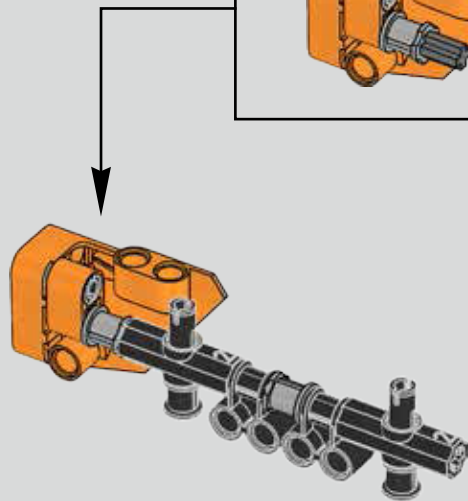
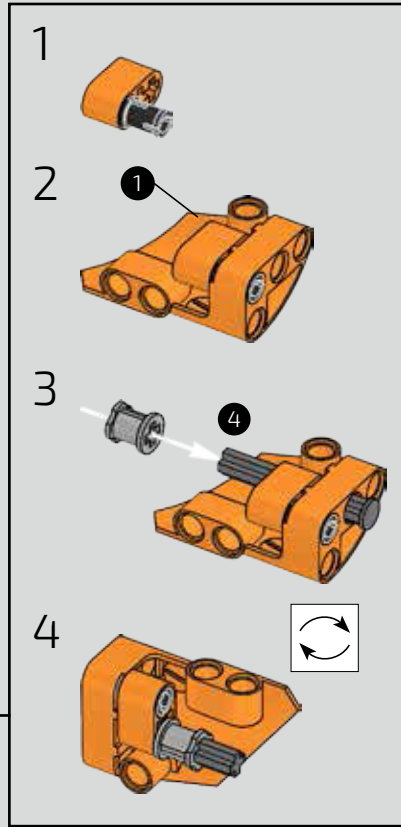

612

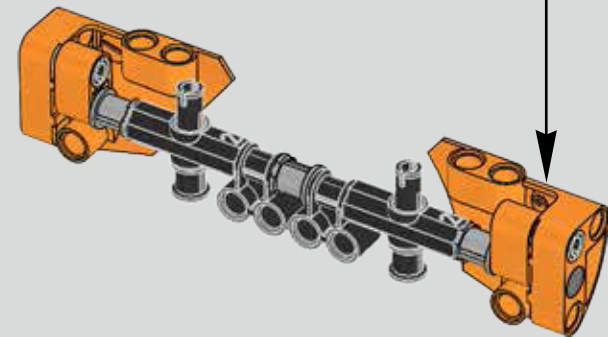
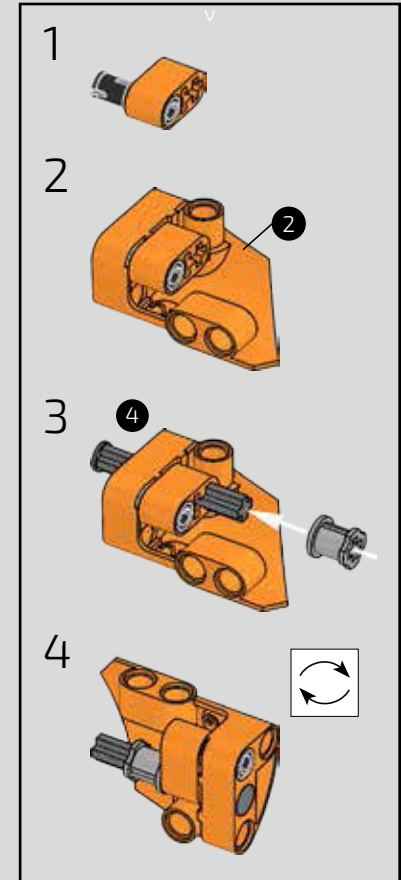



613

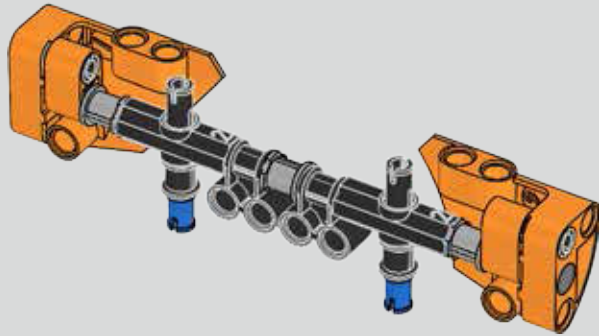

614

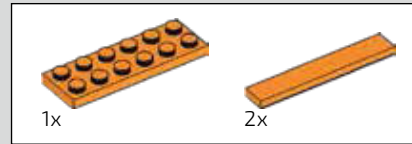
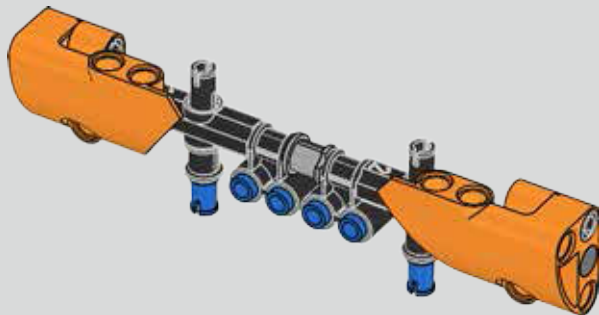
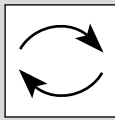

615

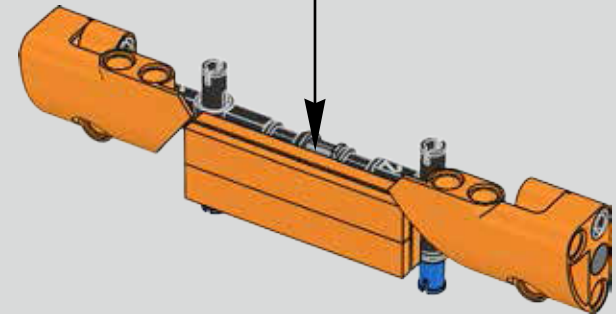
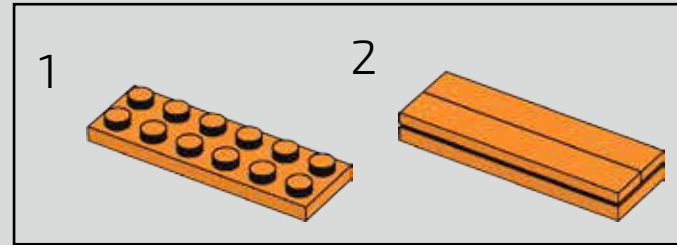

616

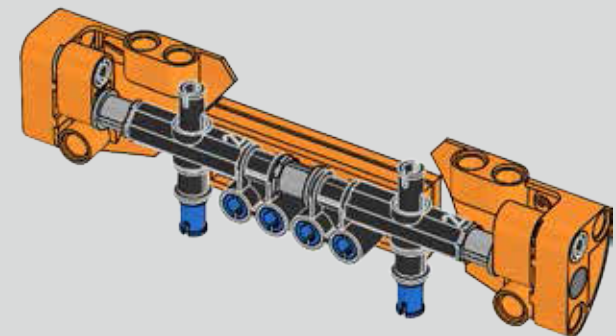
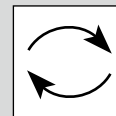

617

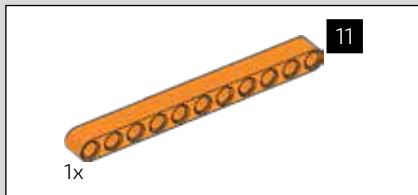
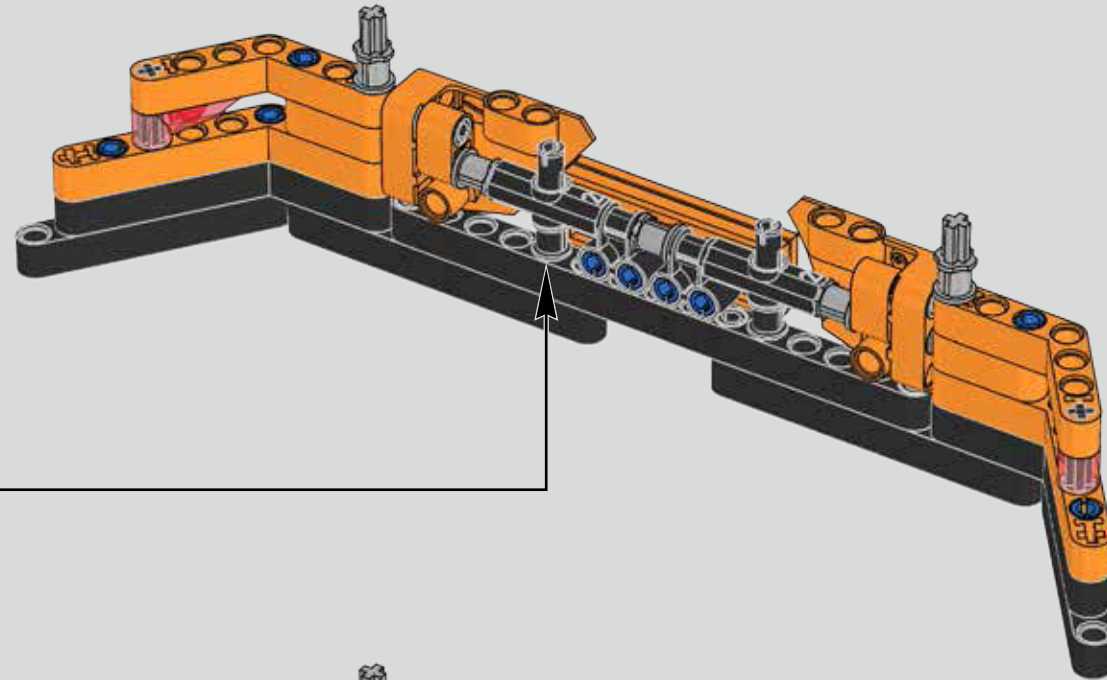

618

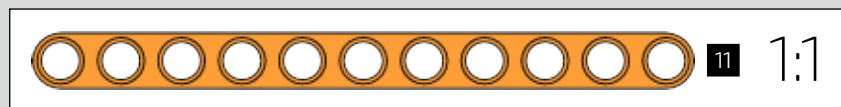
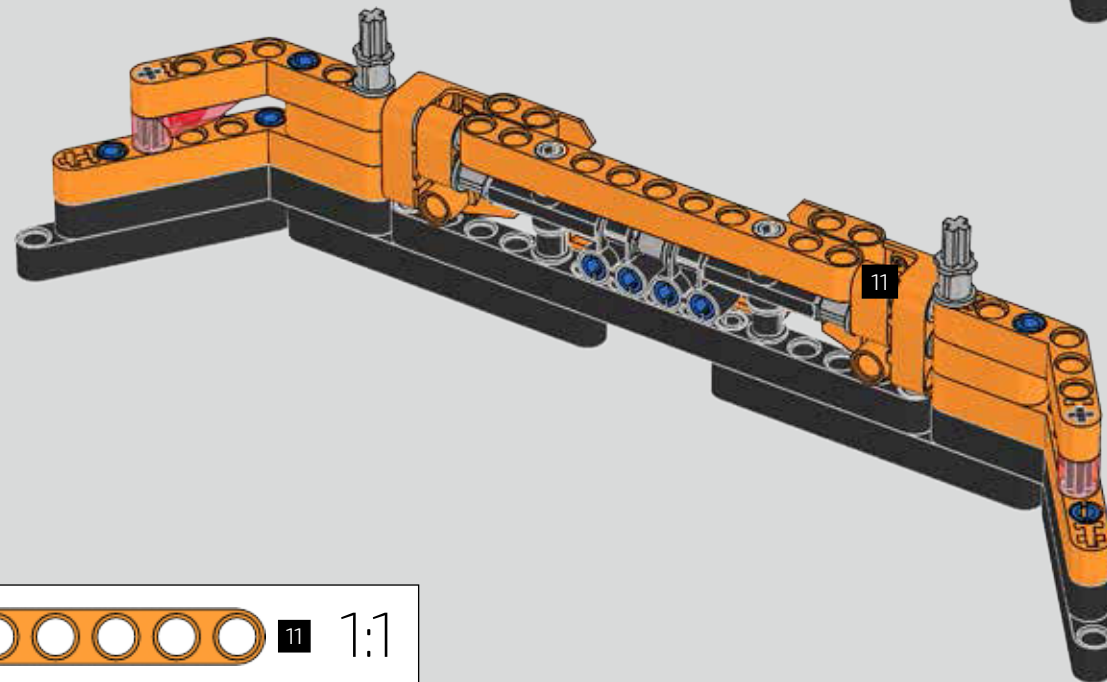



619

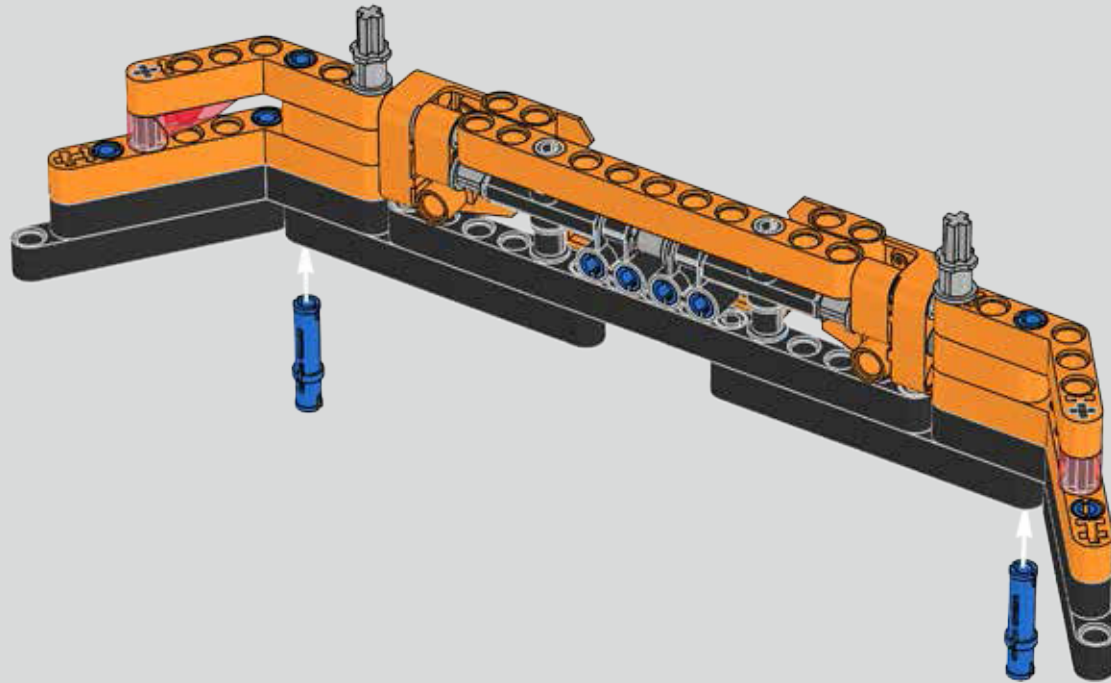

620

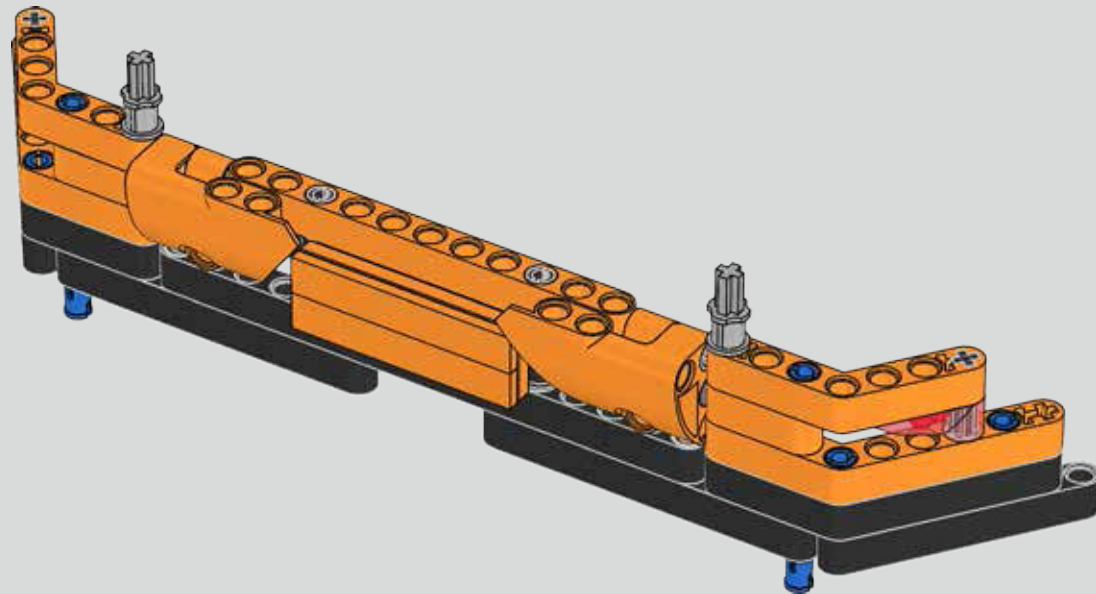
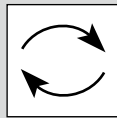

621

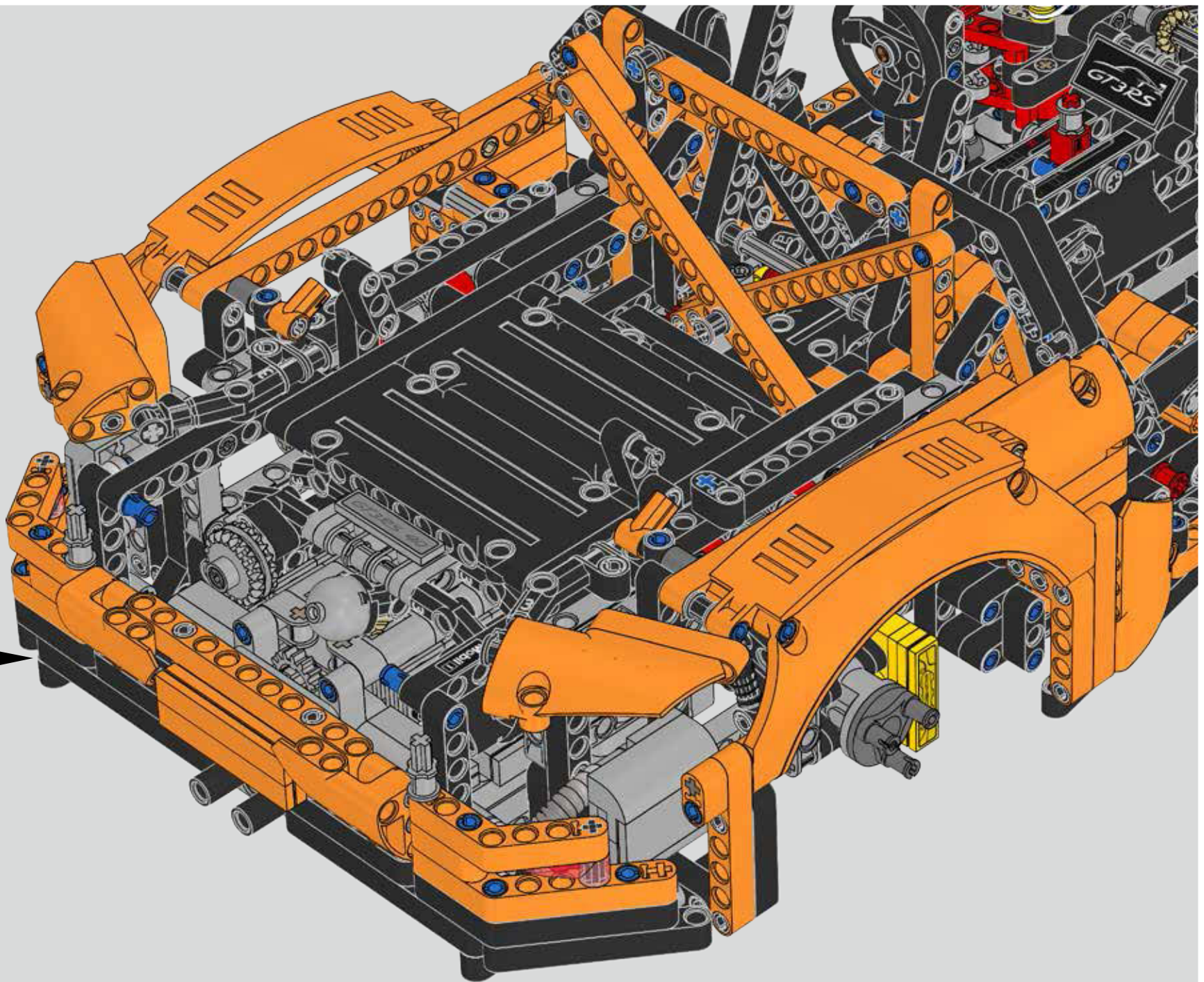

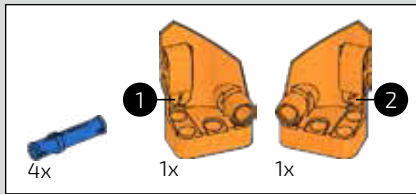

622

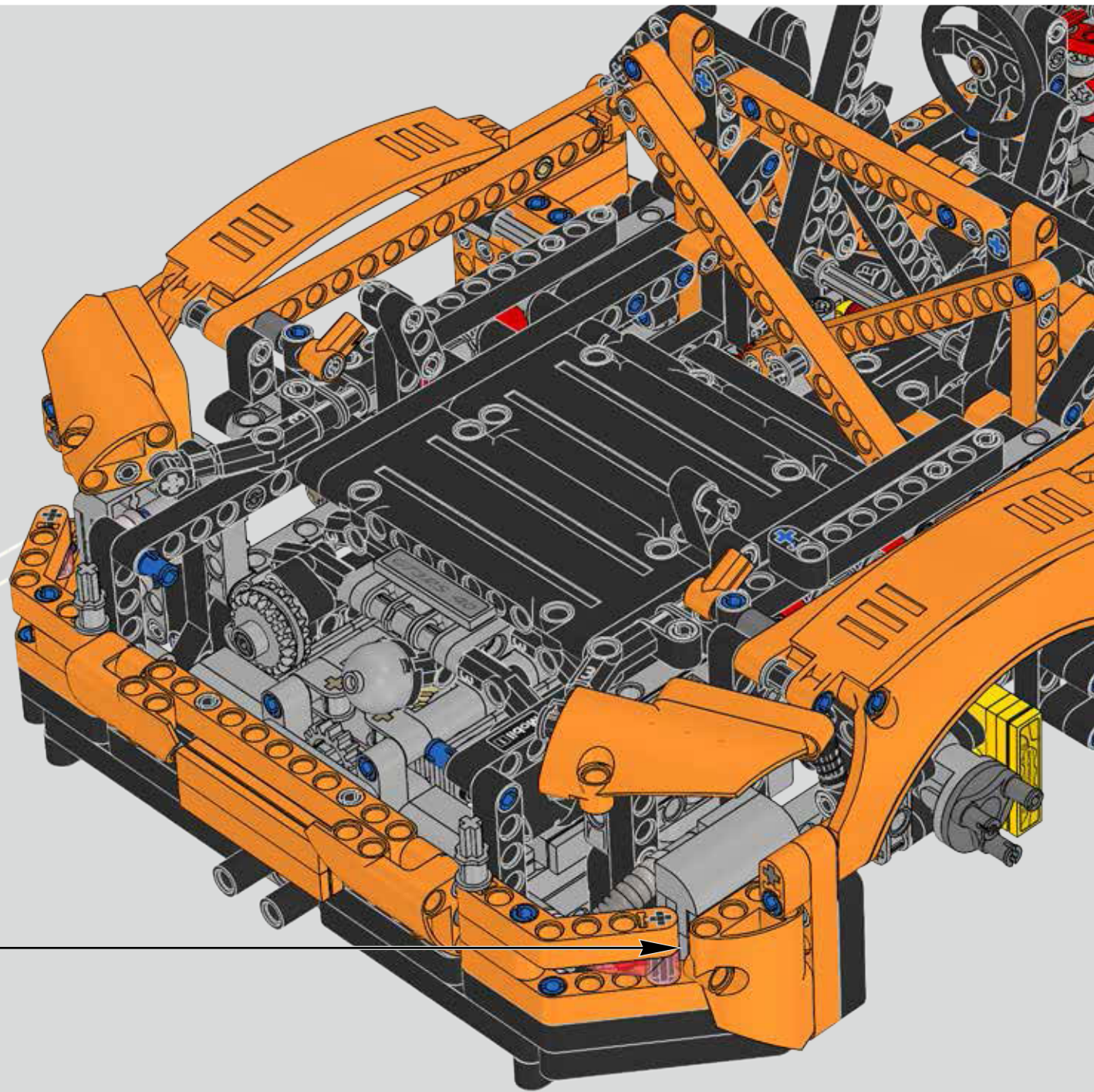
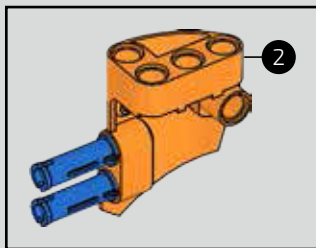
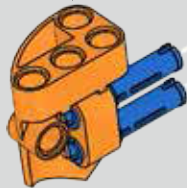
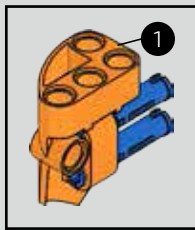

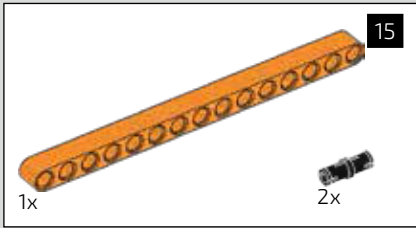
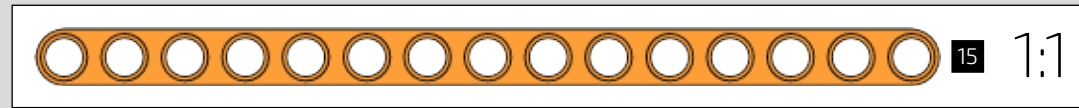
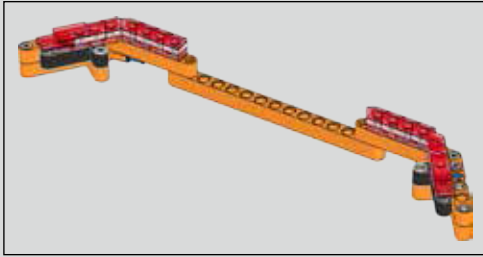

623

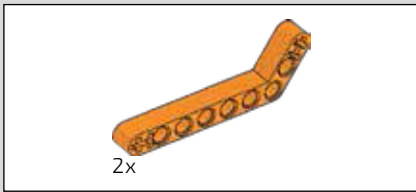
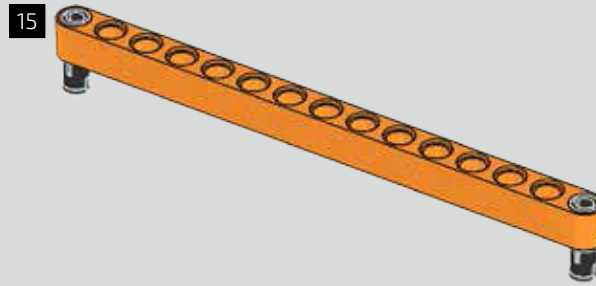

624

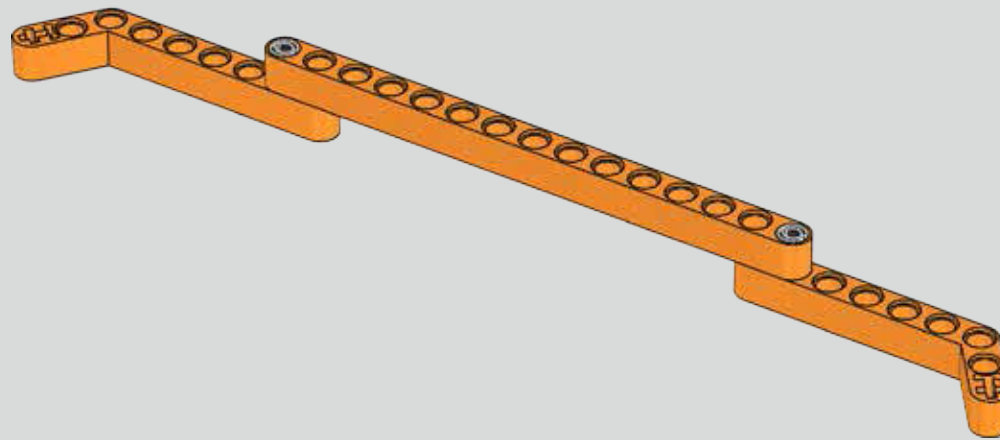



625

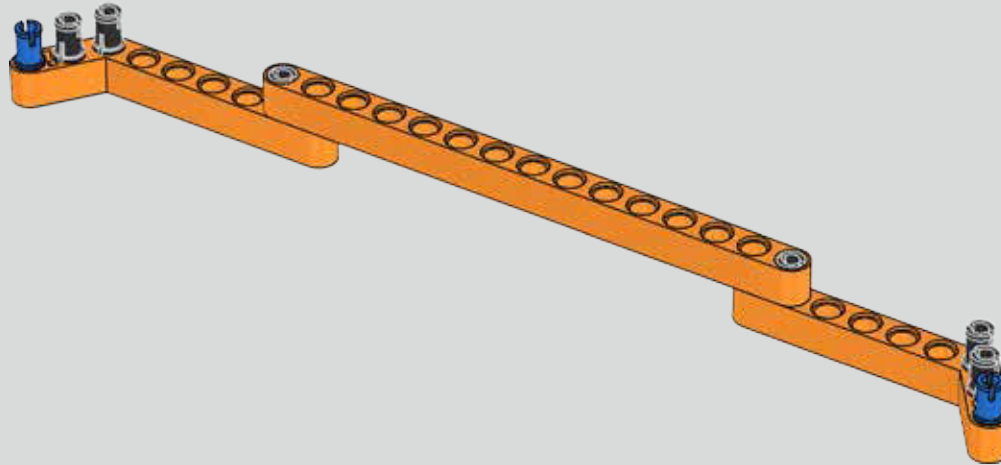

626

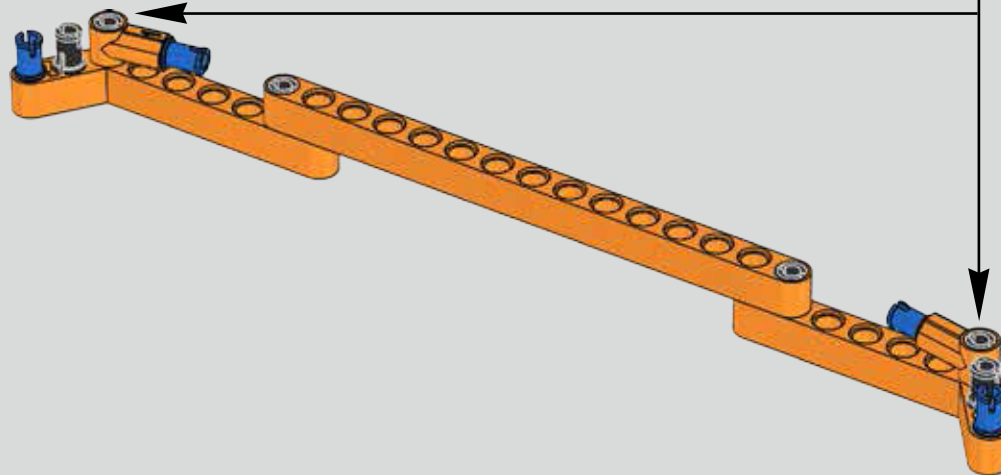
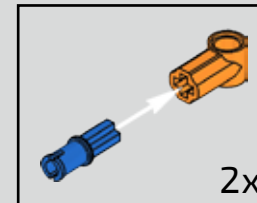

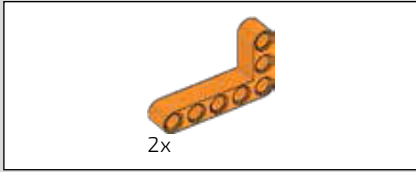

627

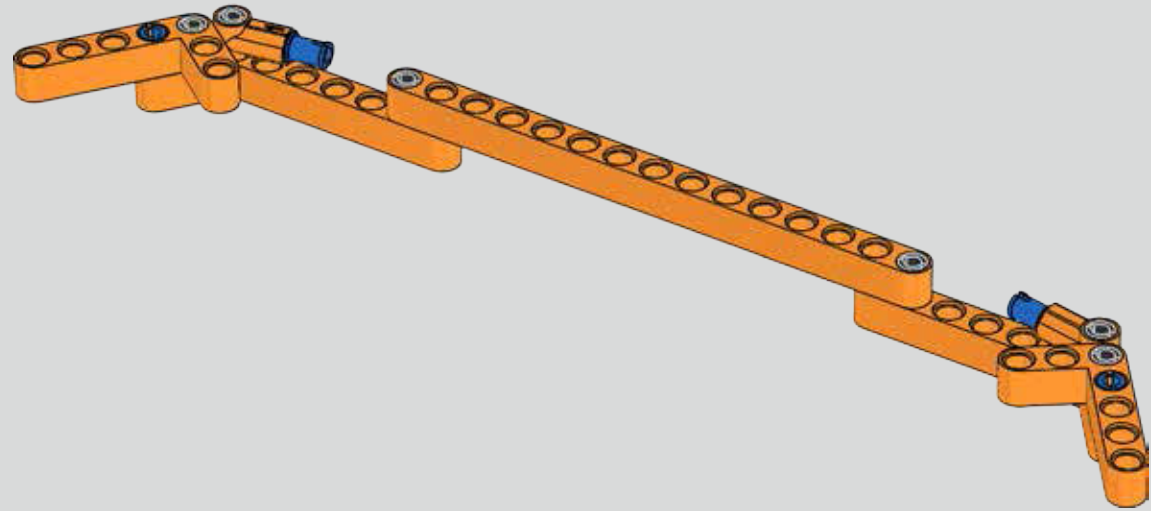

628

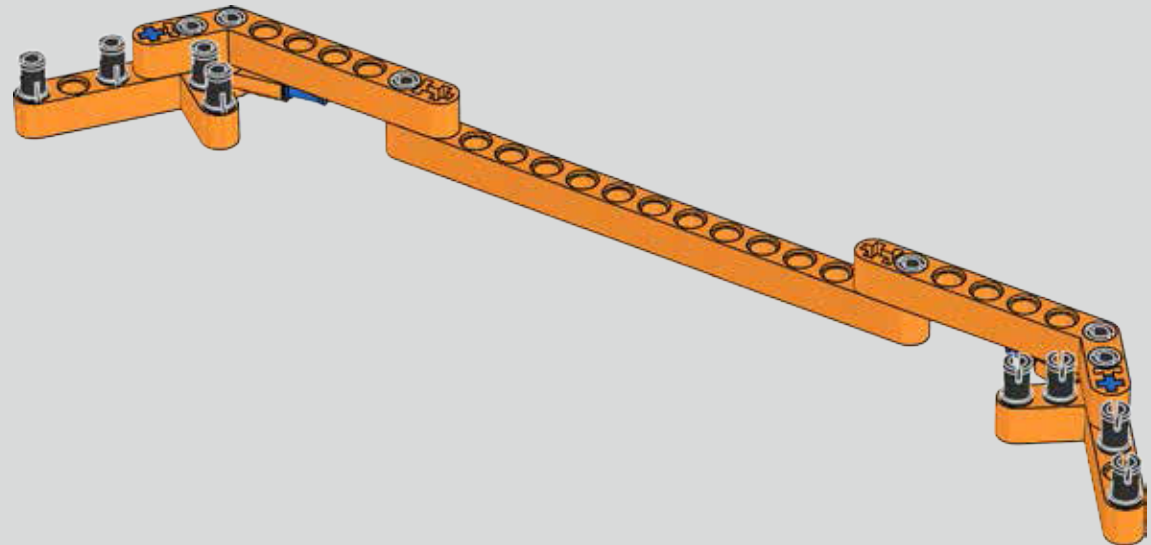
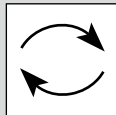

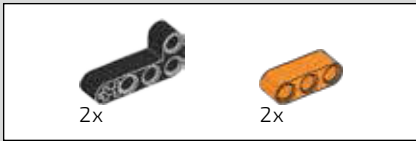

629

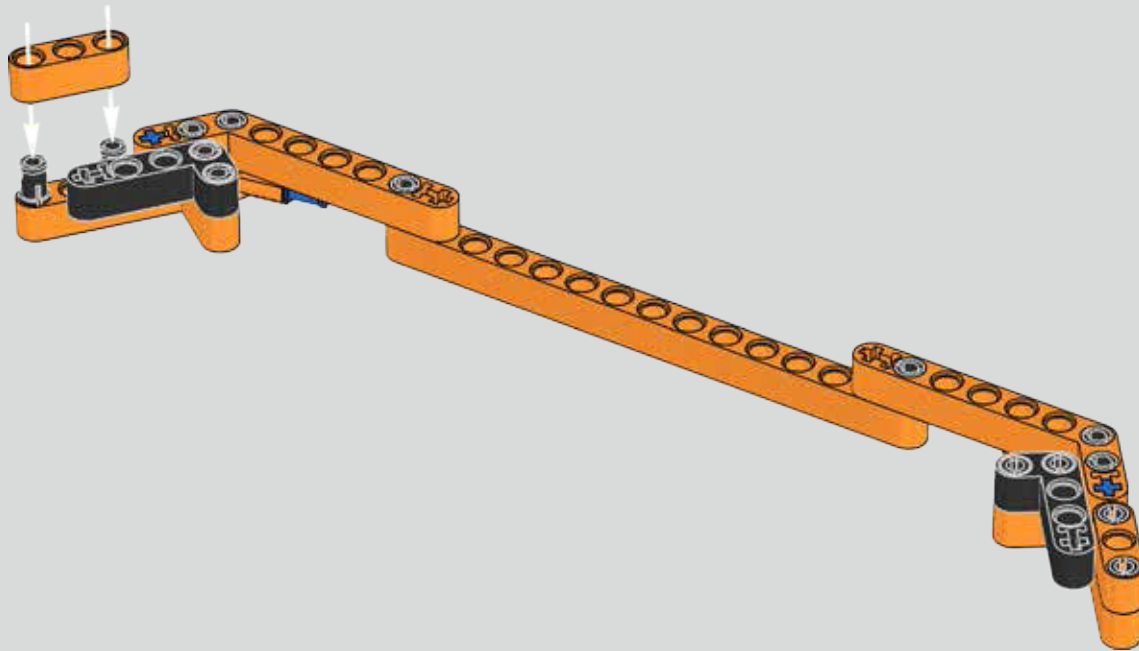

630

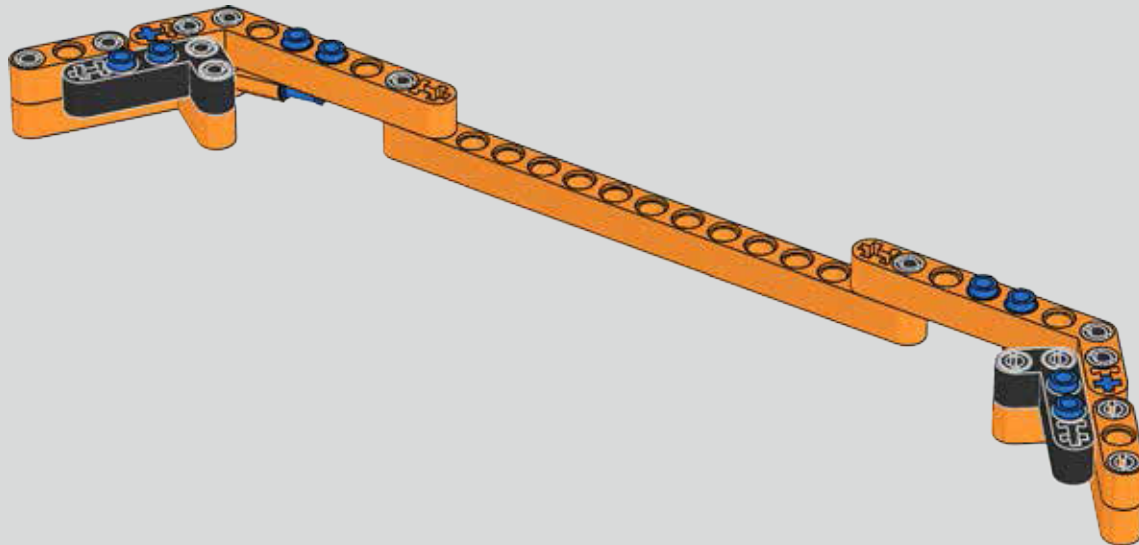

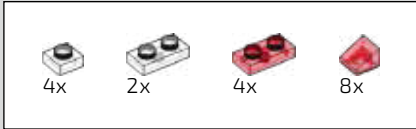

631

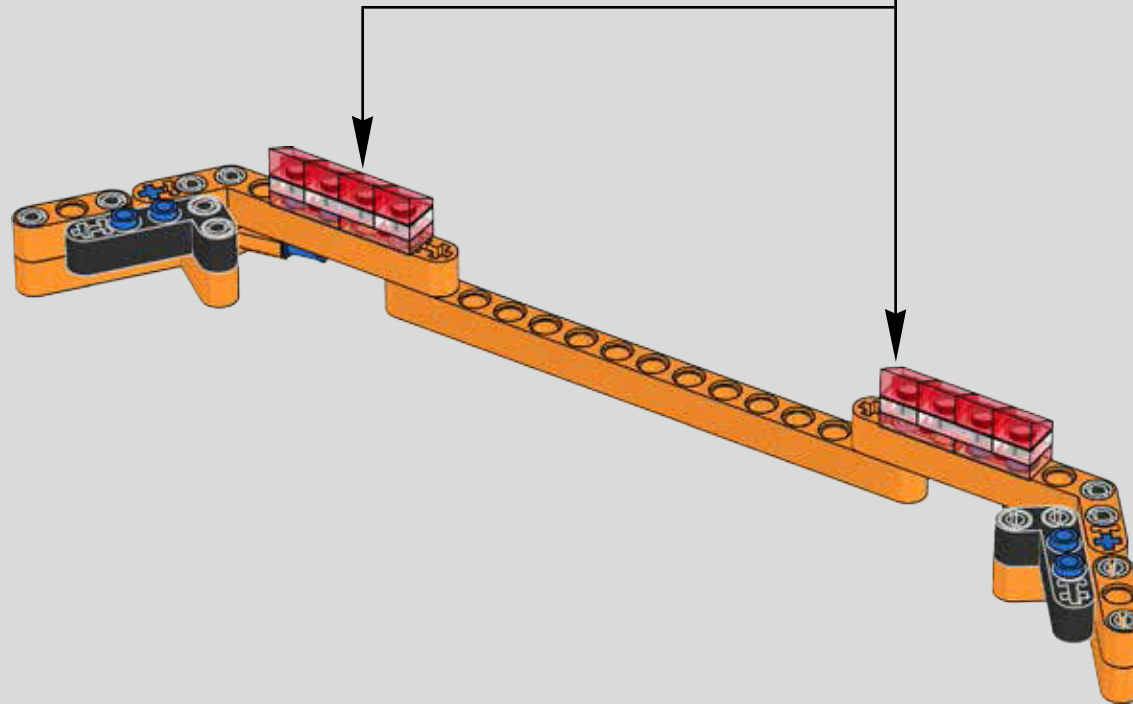
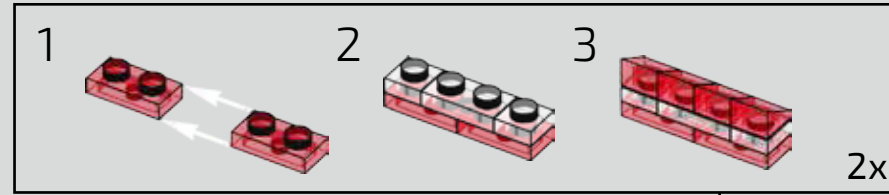

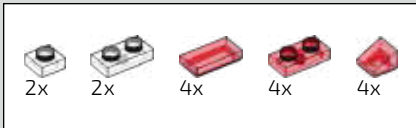

632

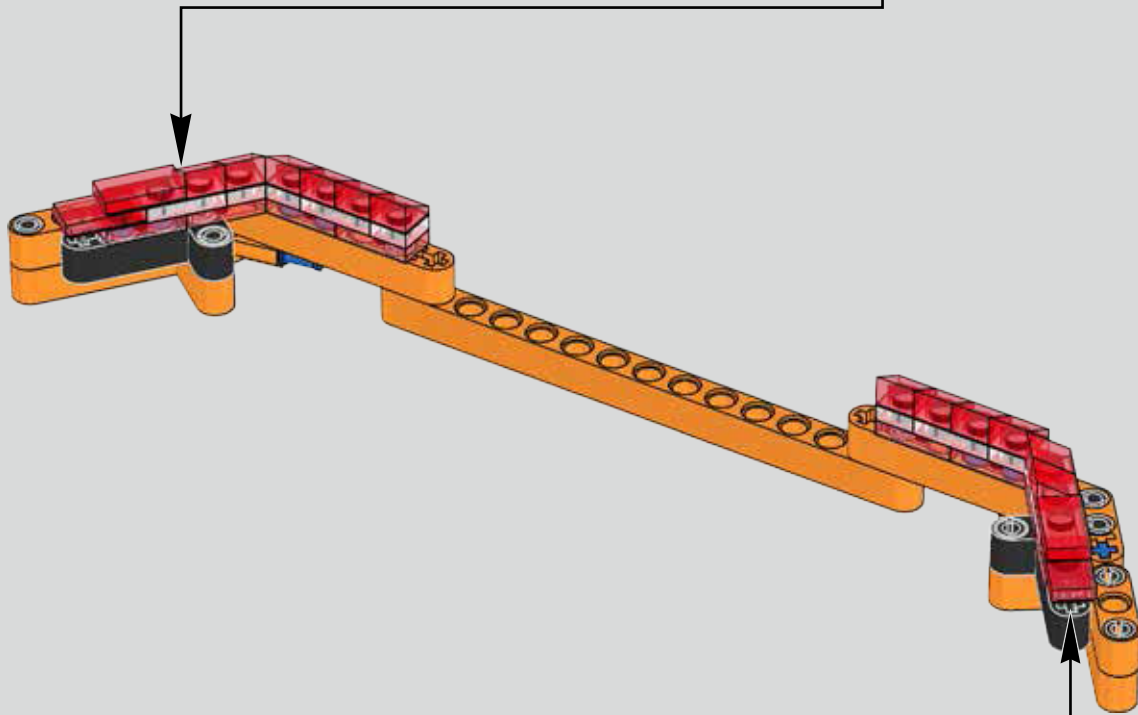
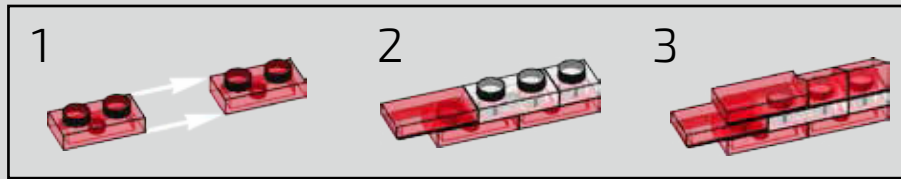

633

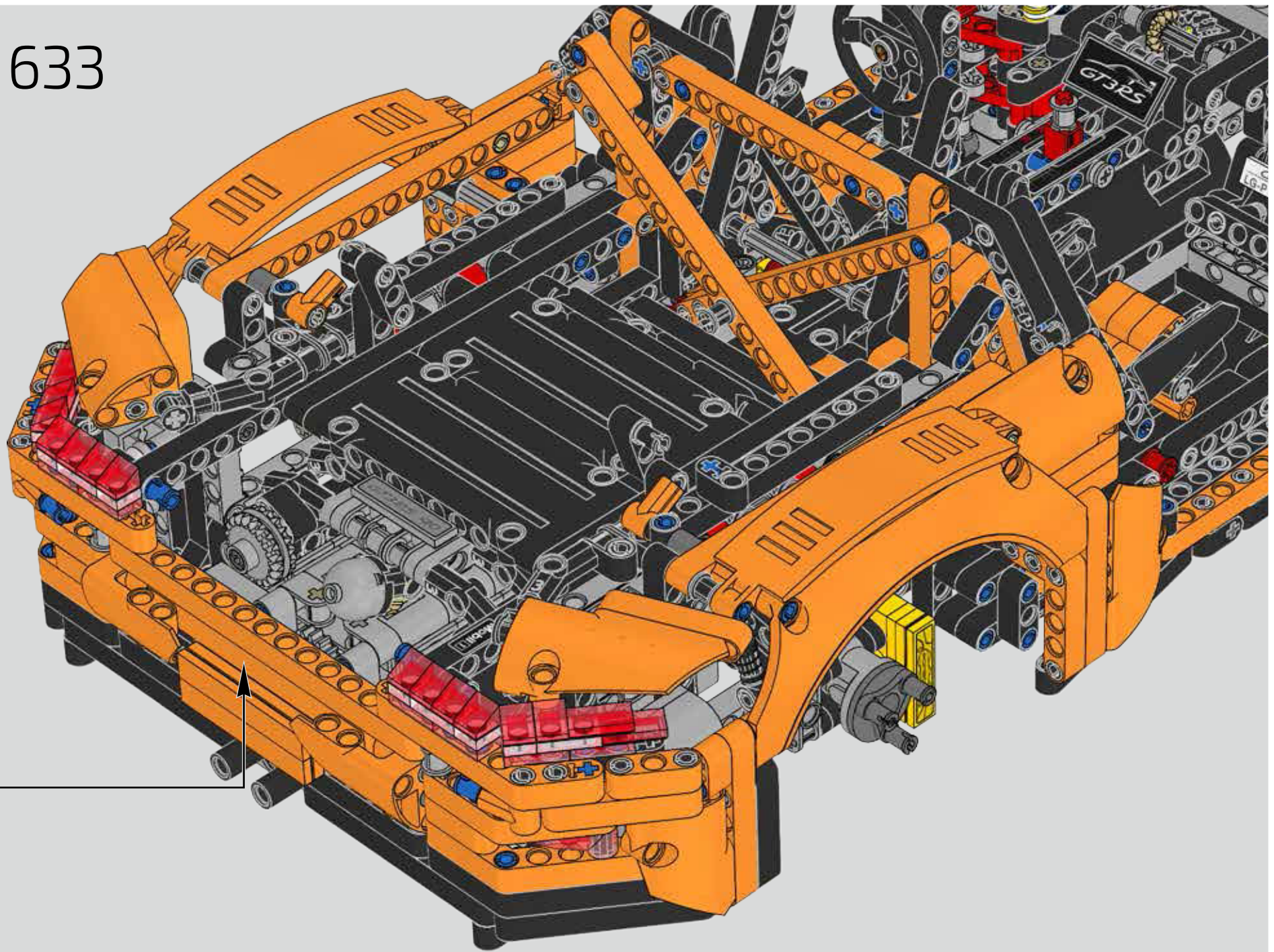



634

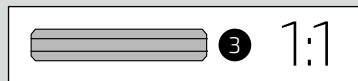
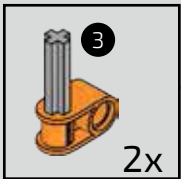
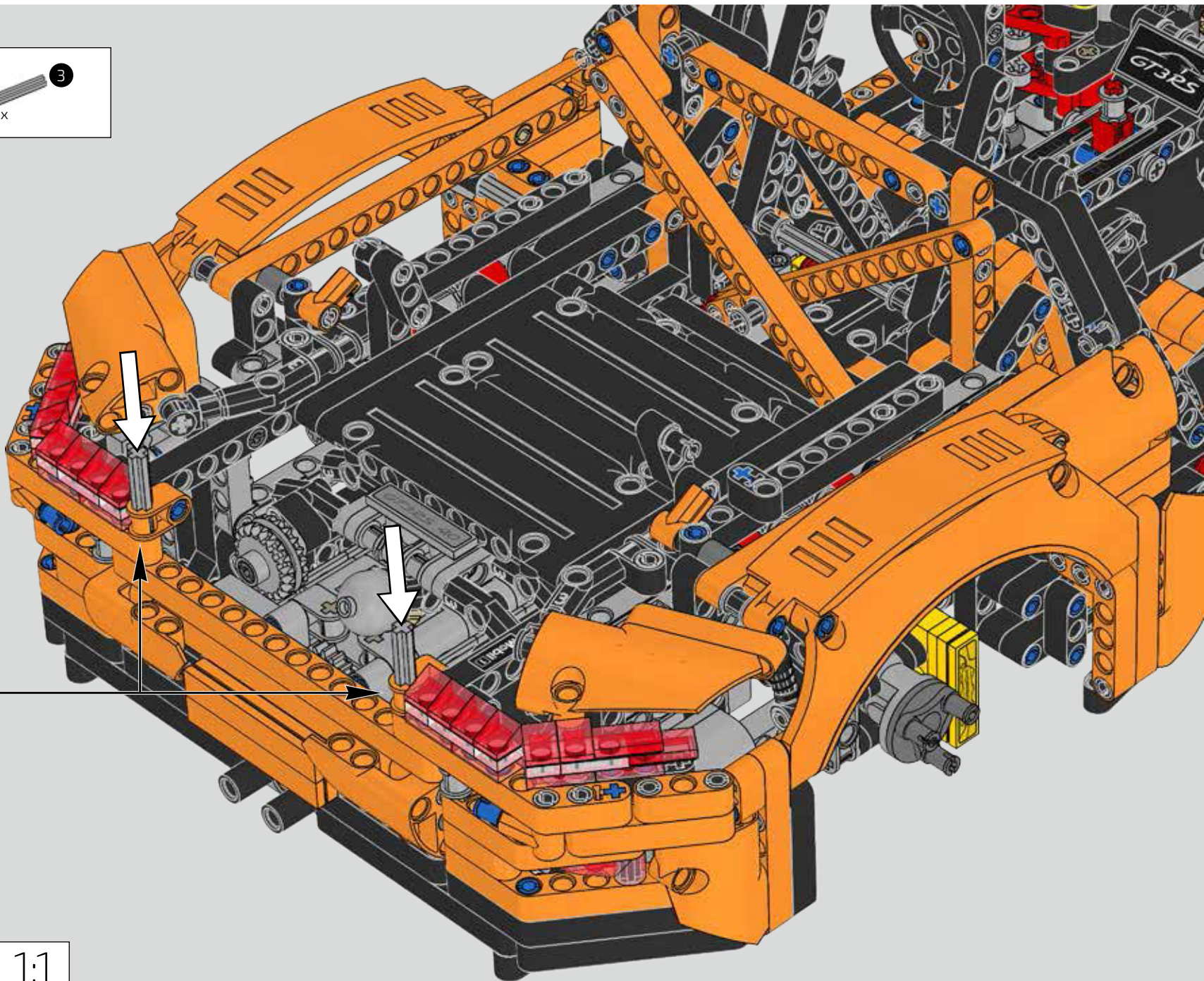

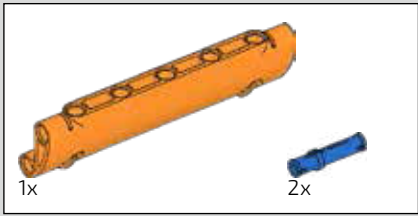

635

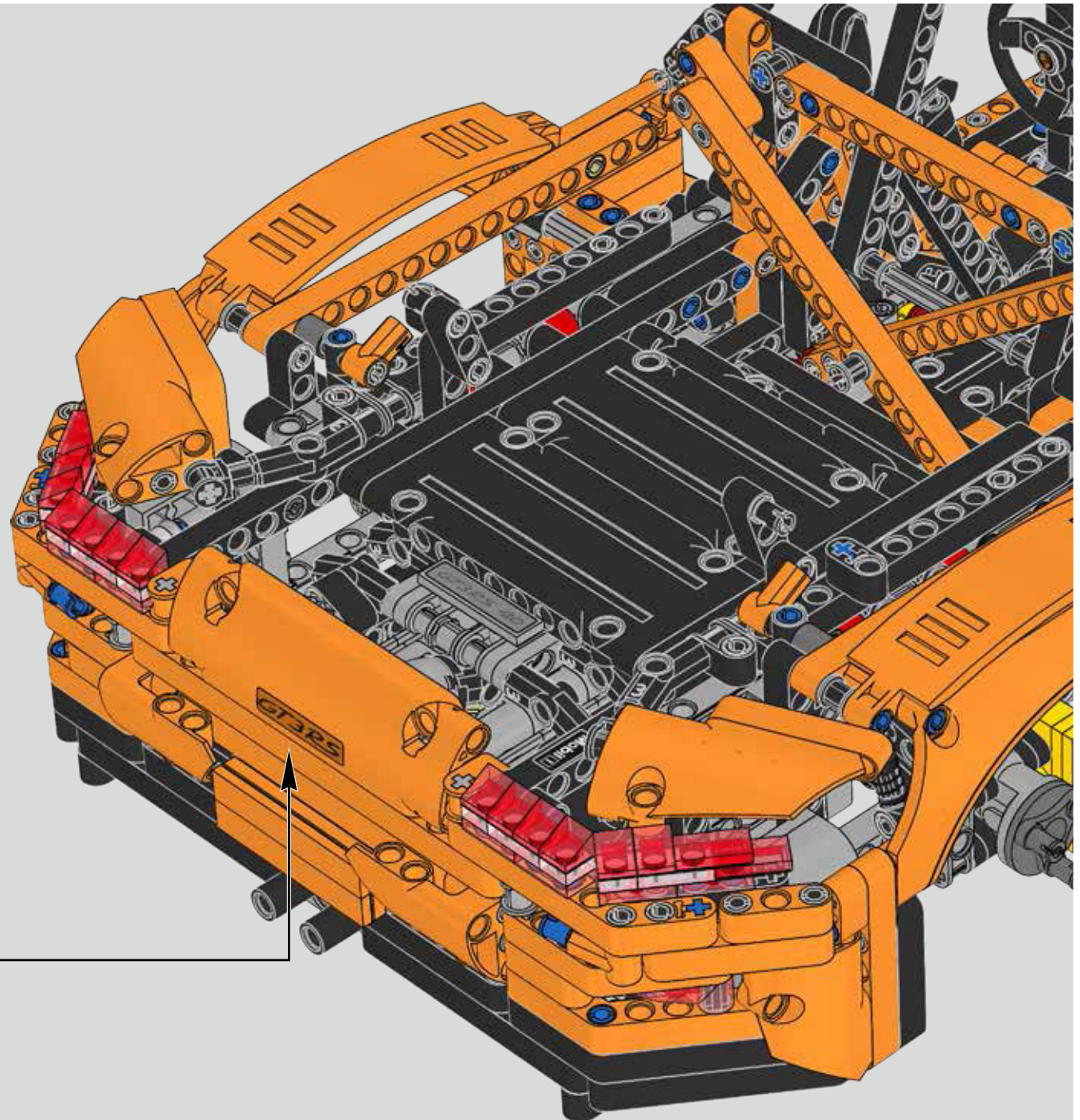
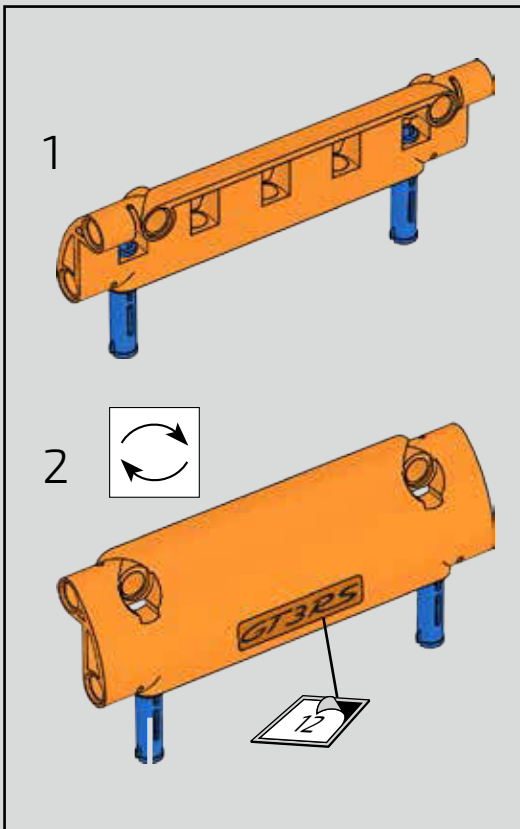

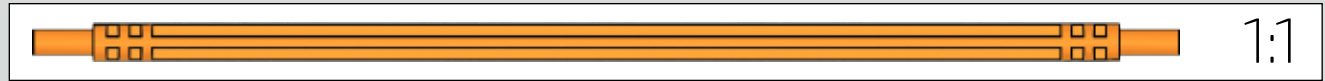
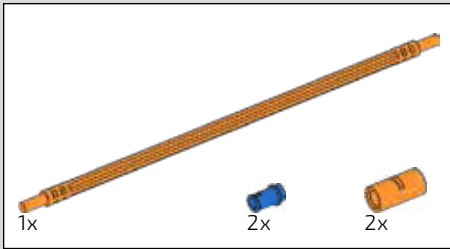

636

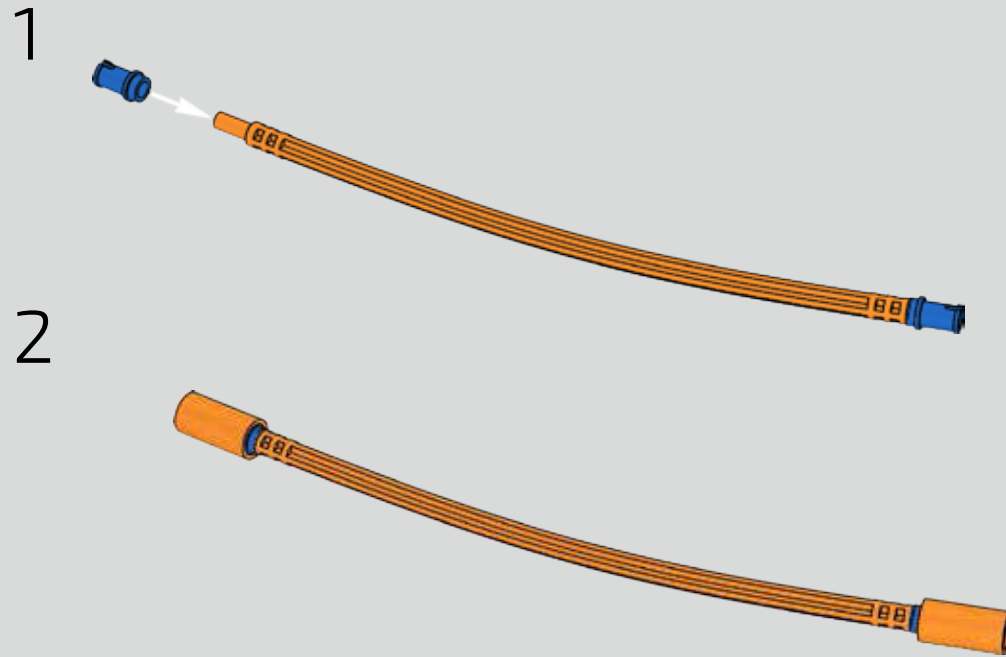

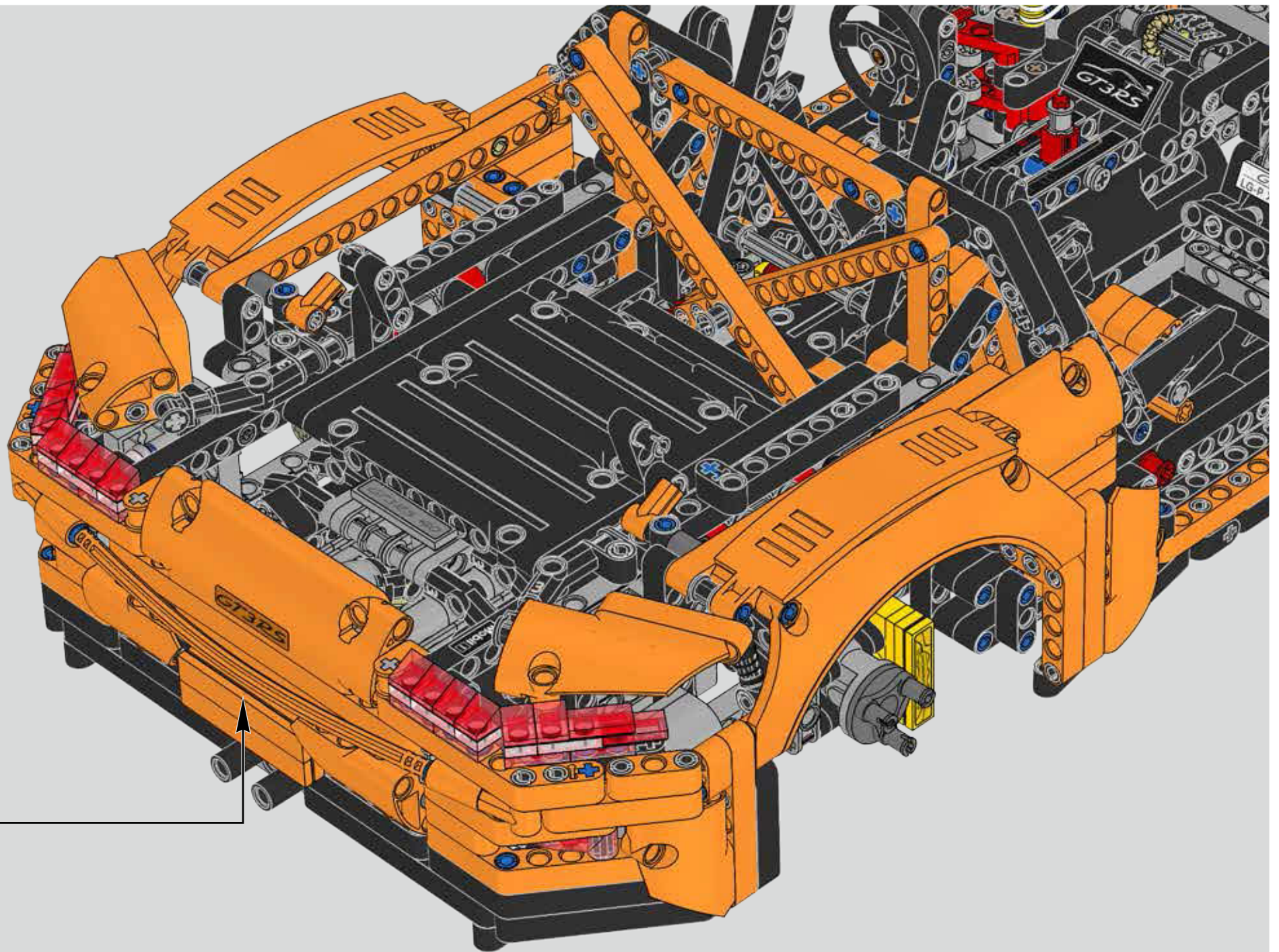

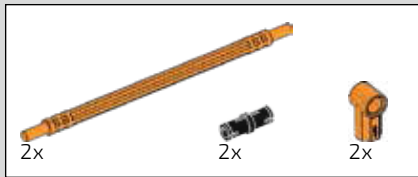

637

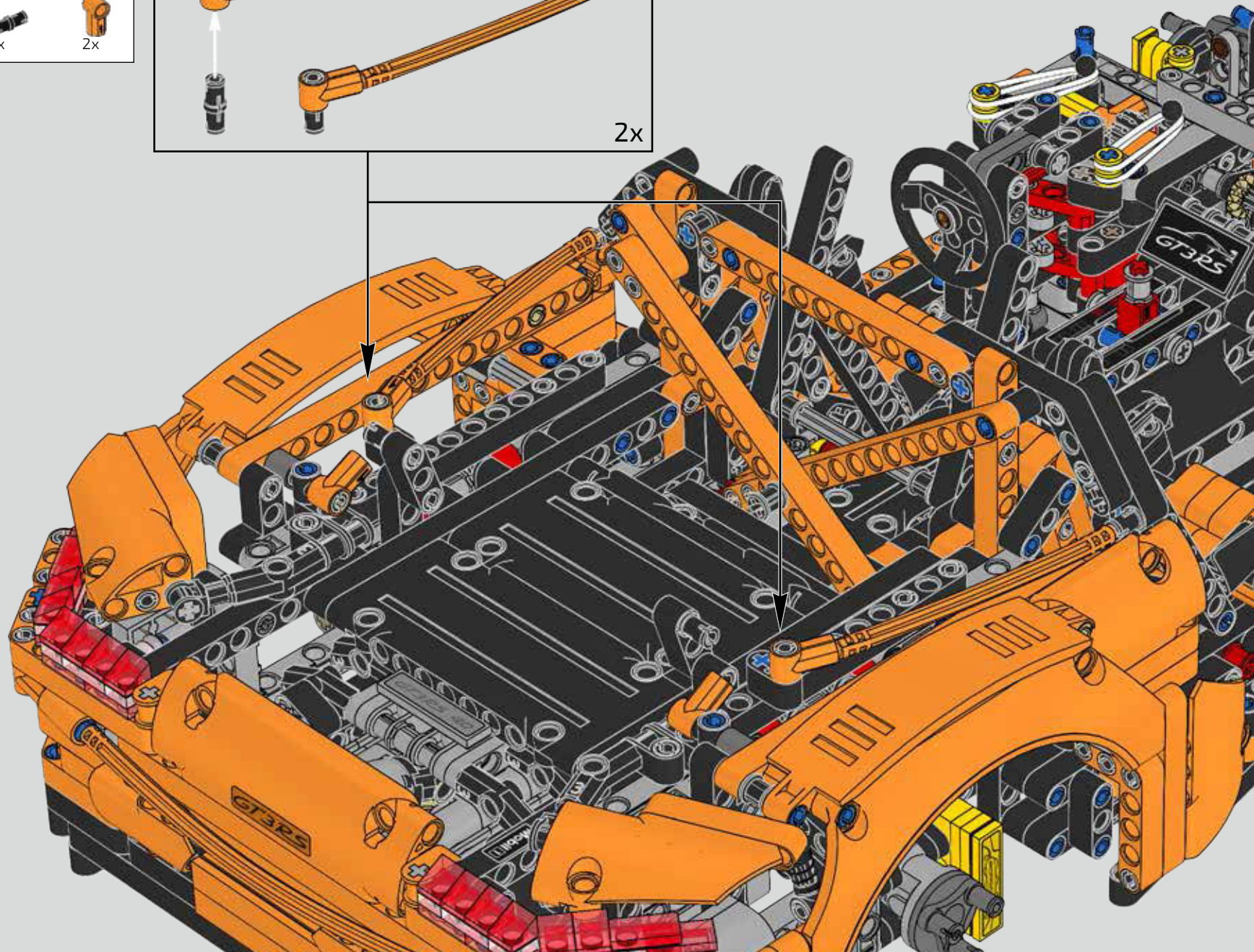
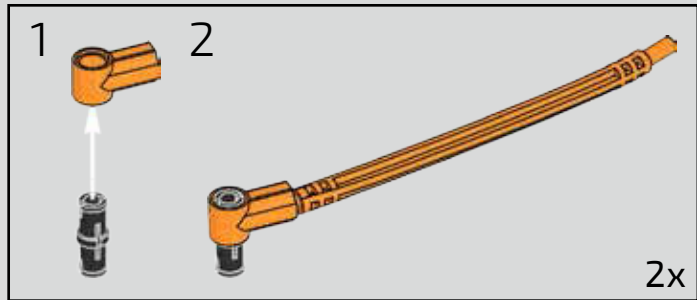

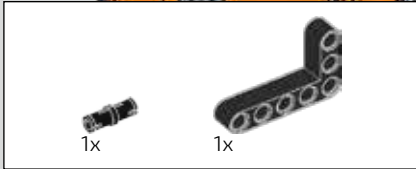

638

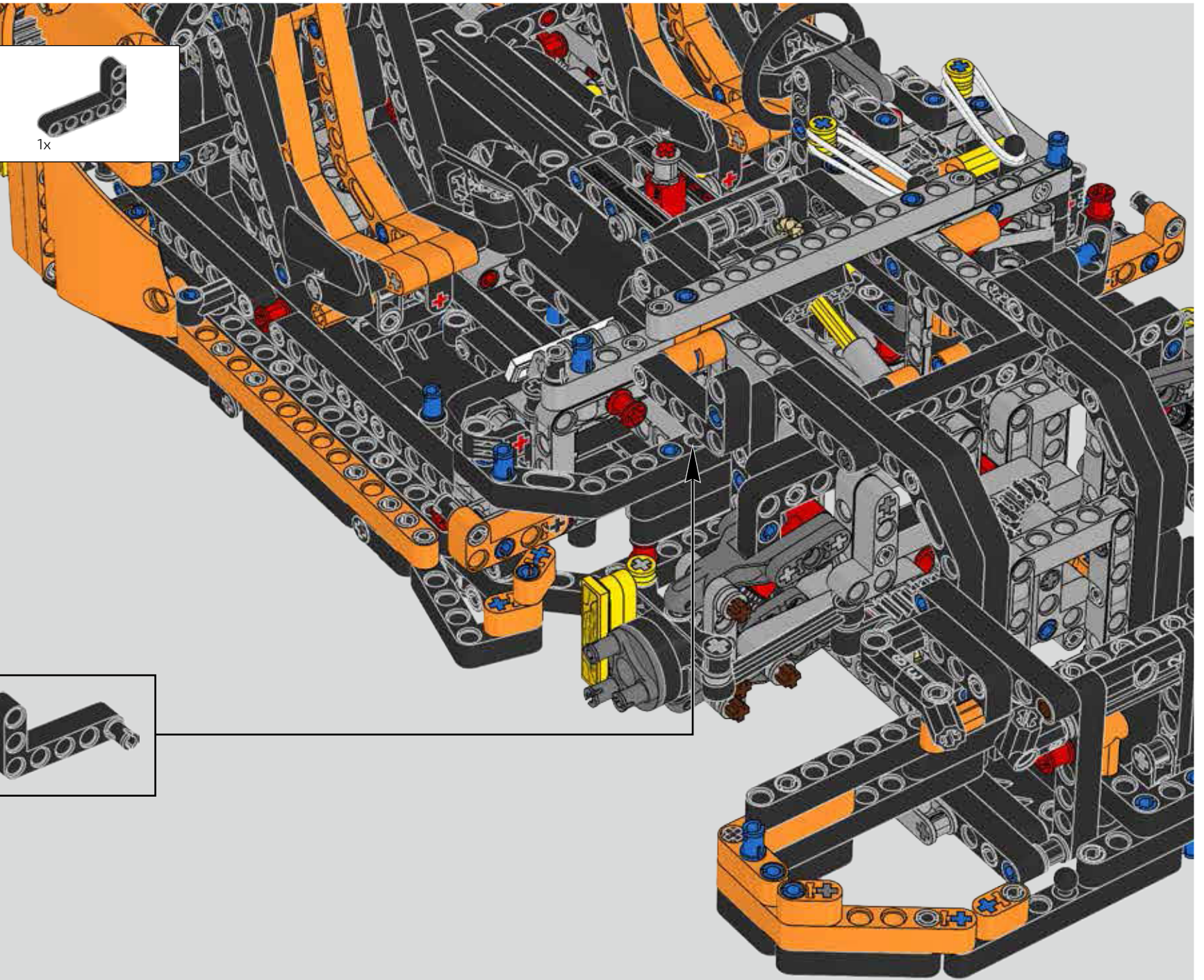
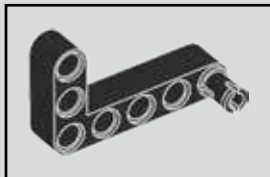
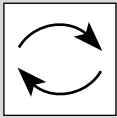

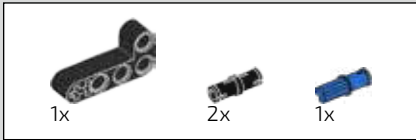

639

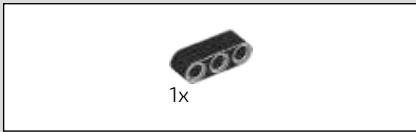

640



641

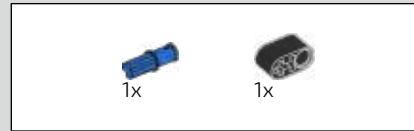

642

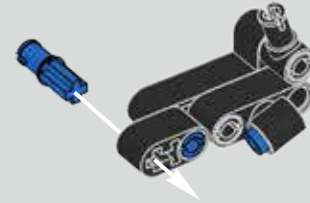

643

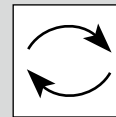

644

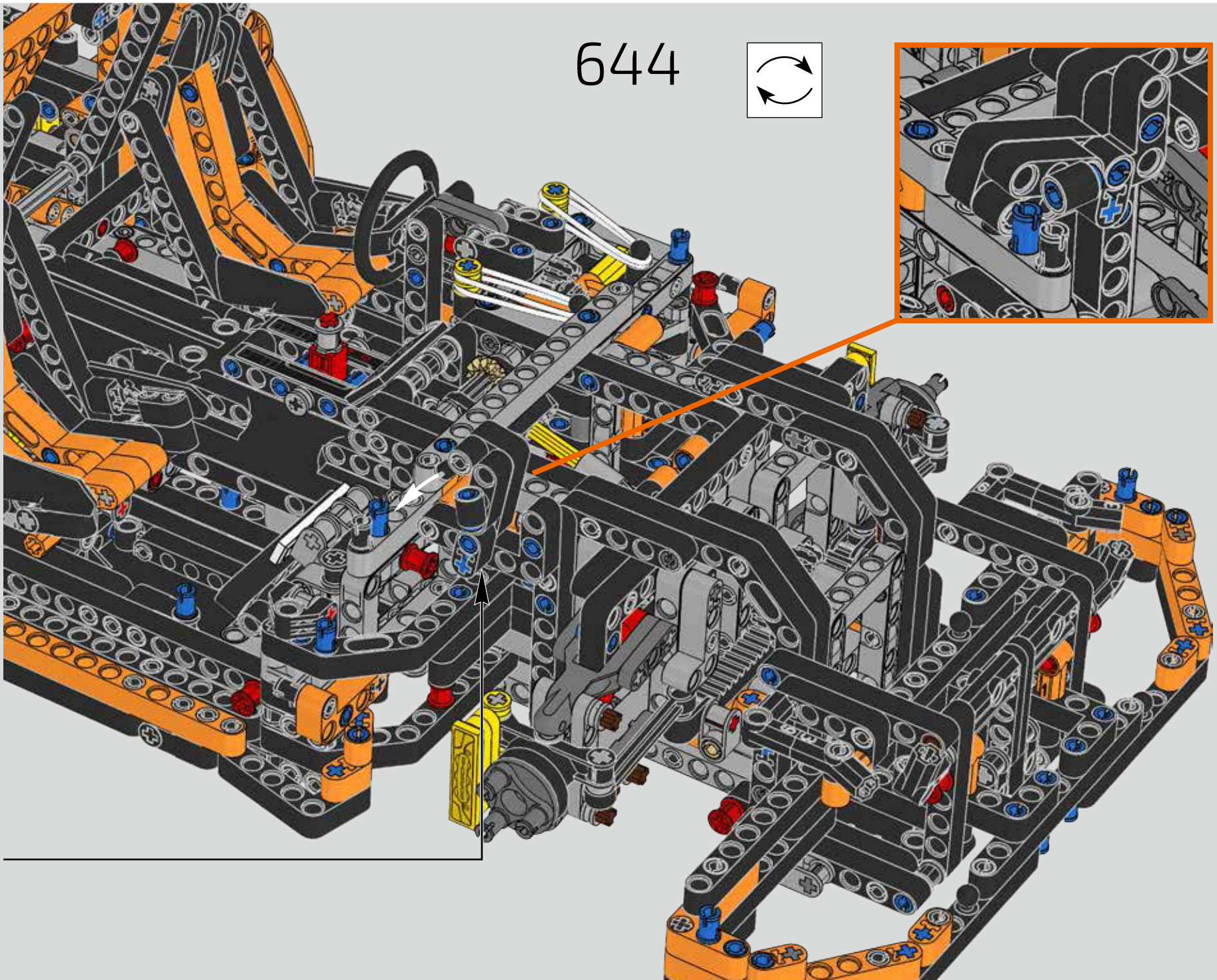
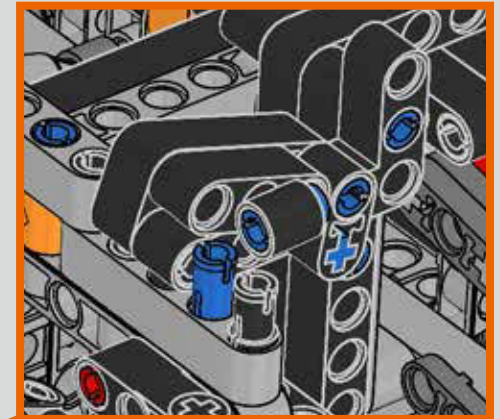
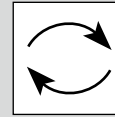

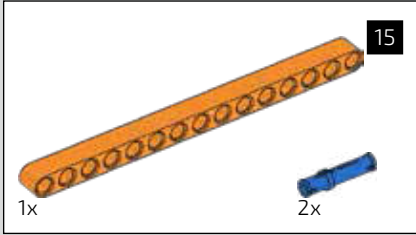
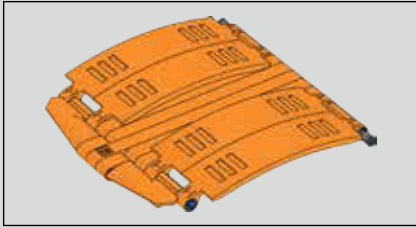

645

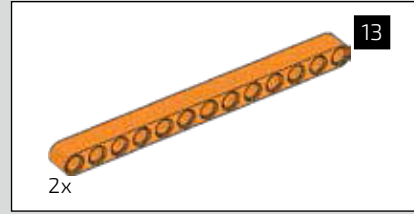
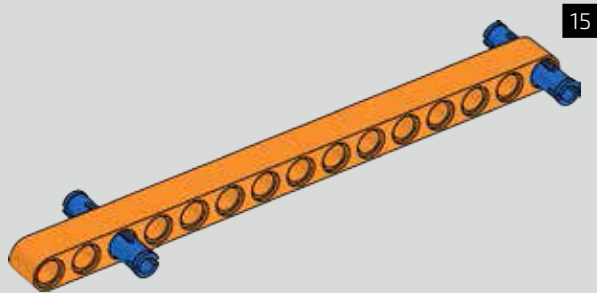

646

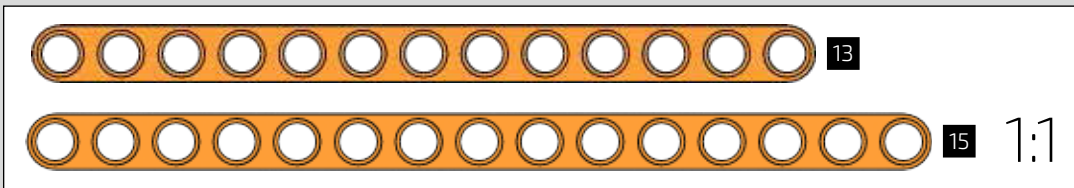
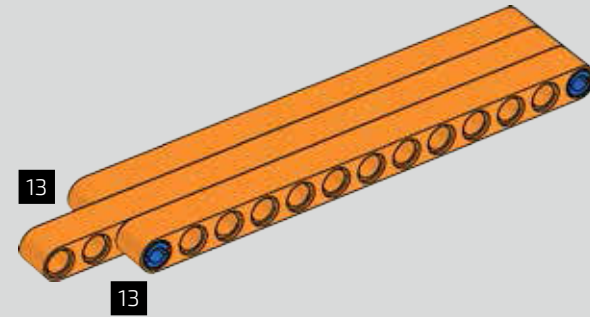



647

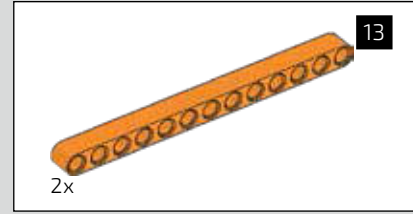
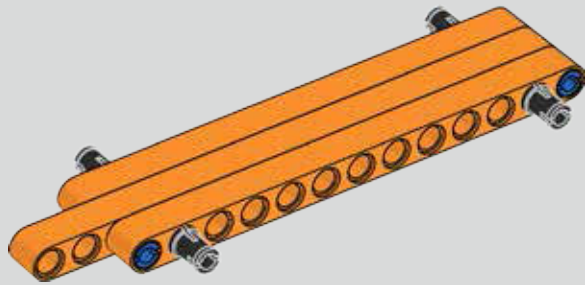

648

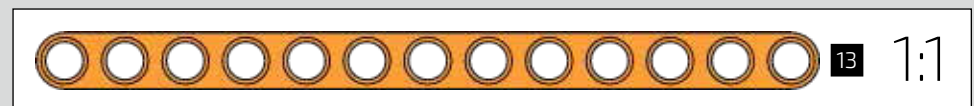
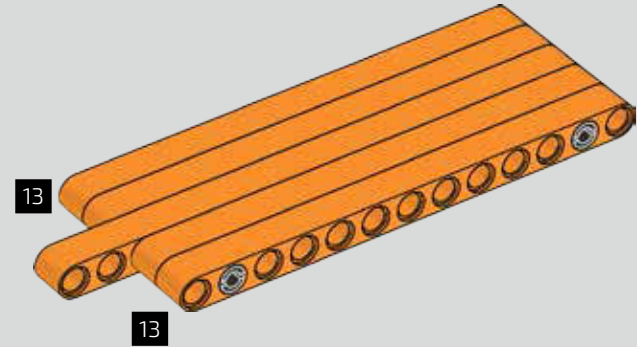

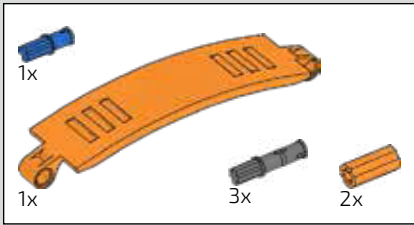

649

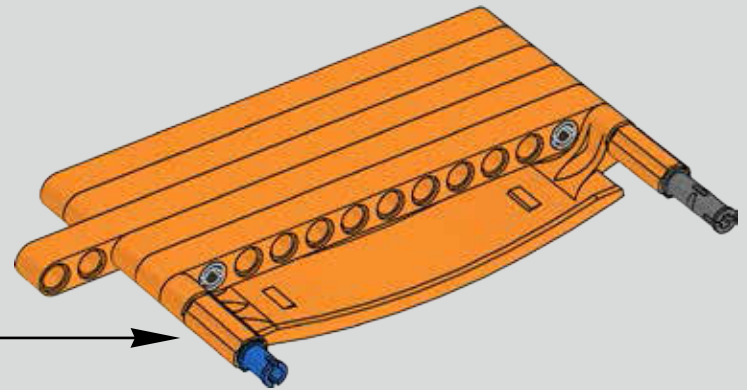
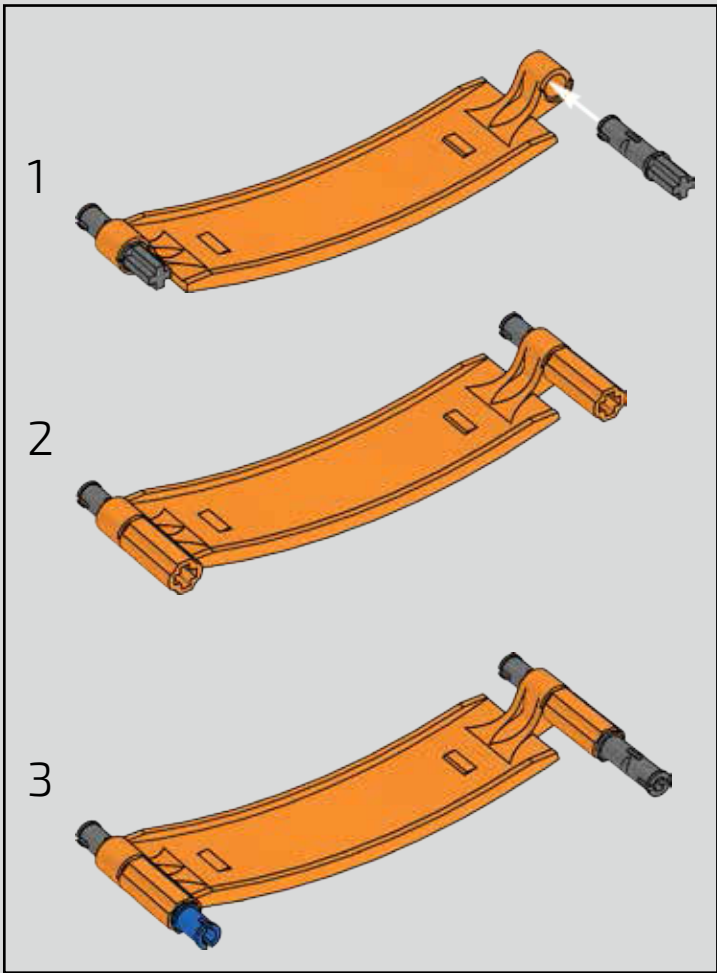

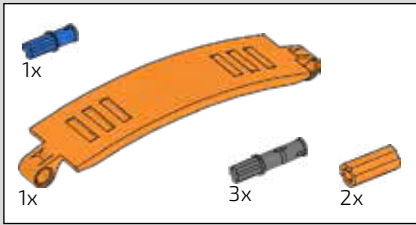

650

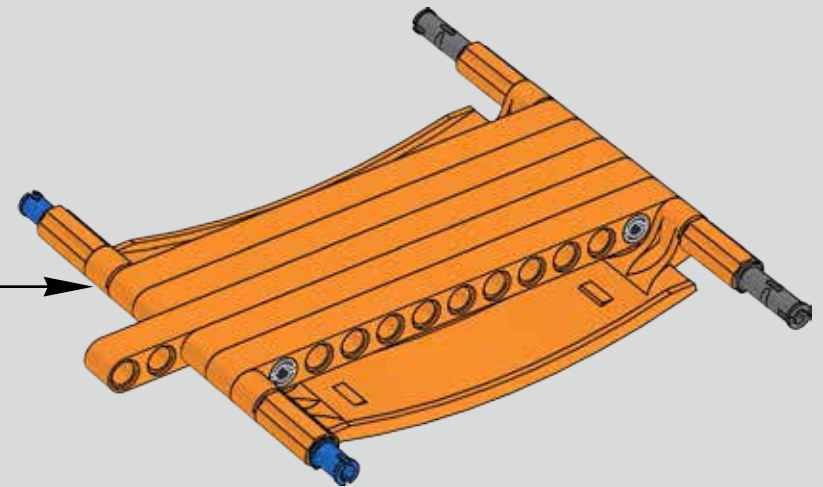
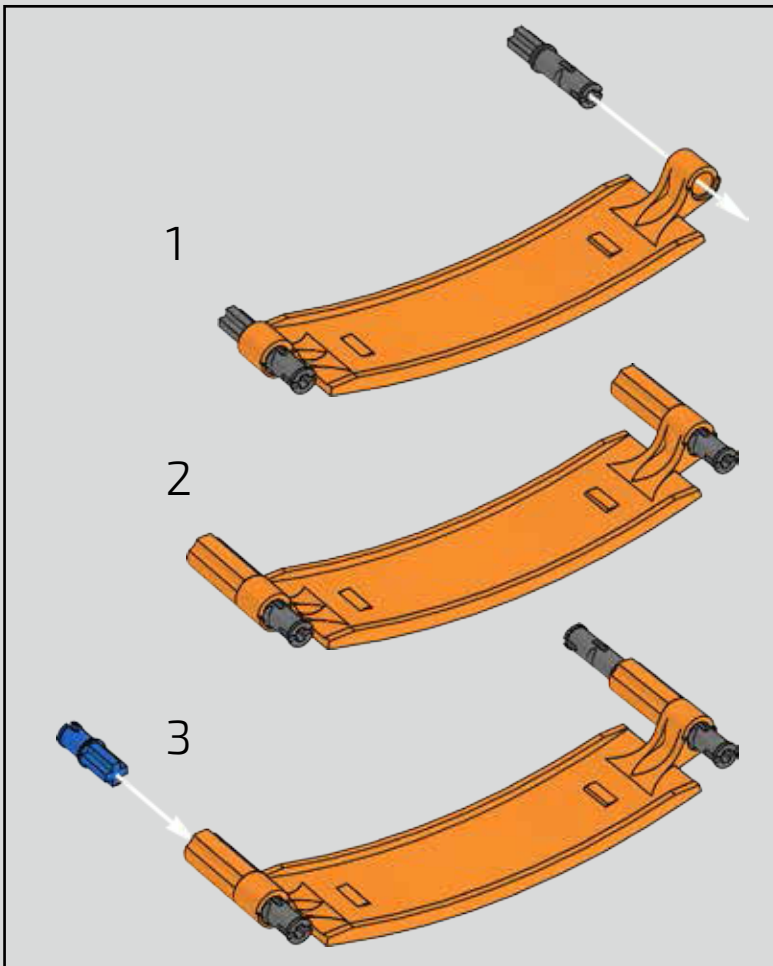

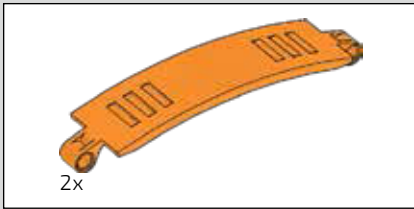

651

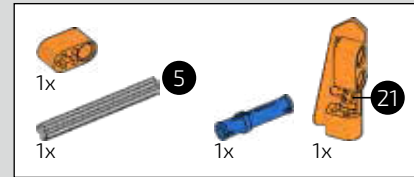
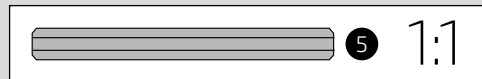
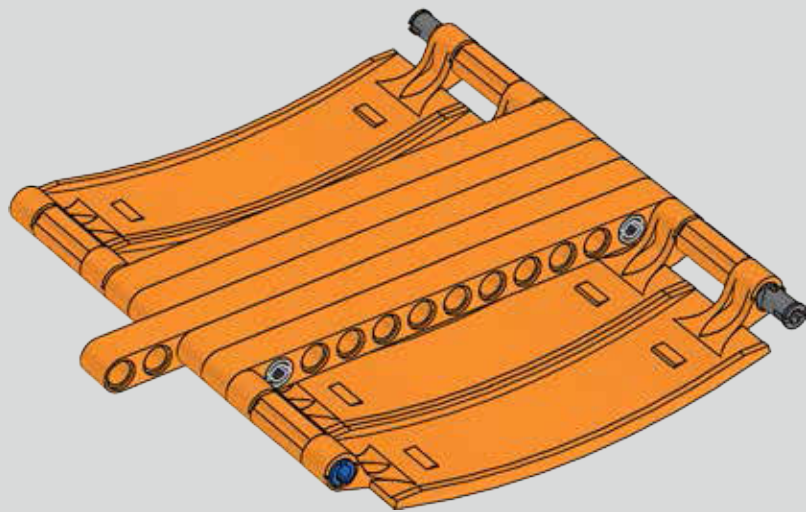

652

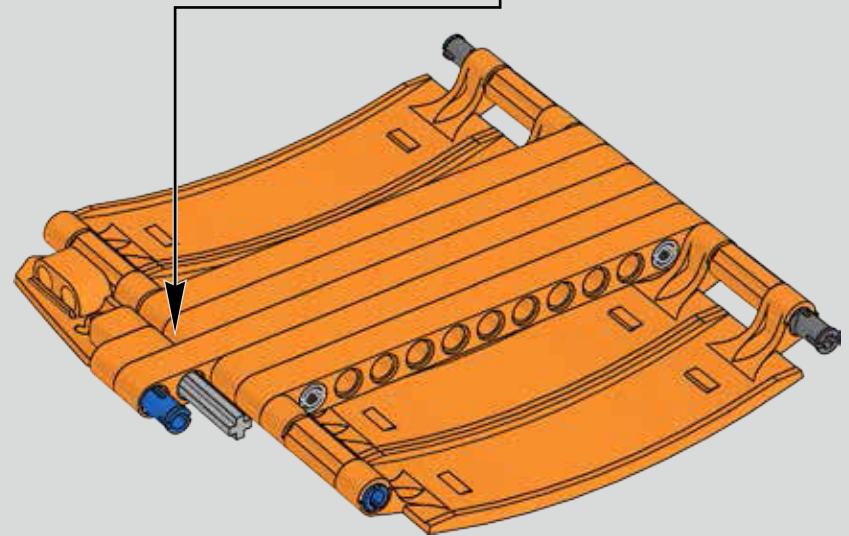
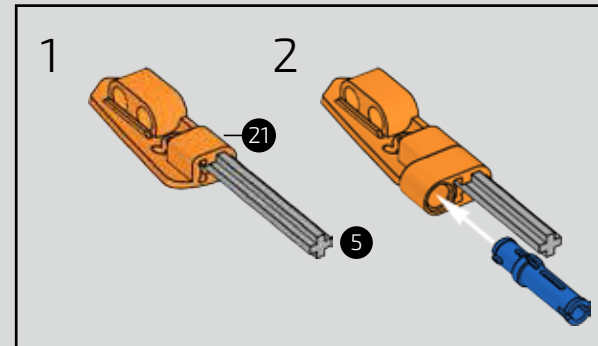

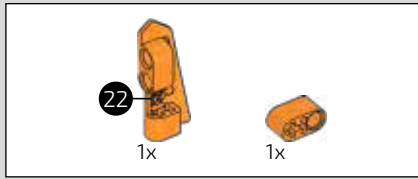

653

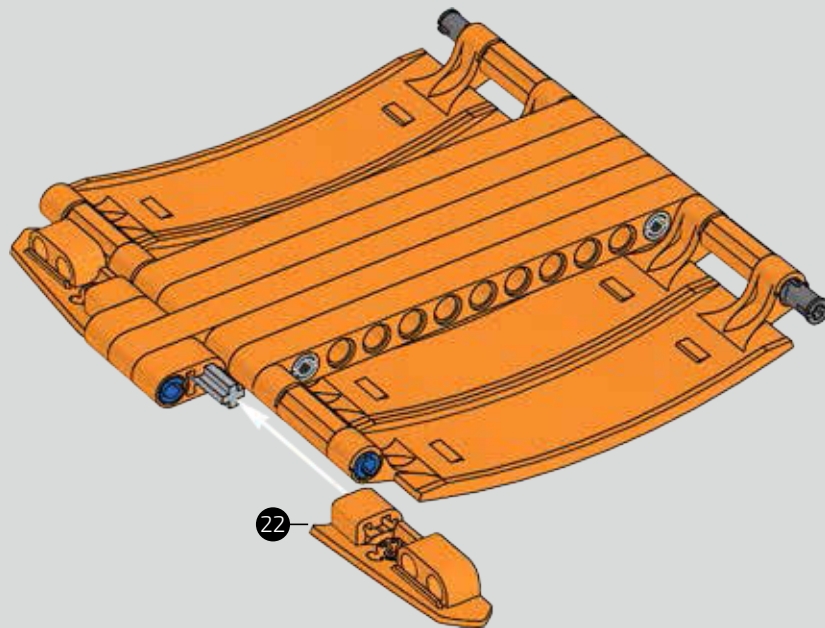

654

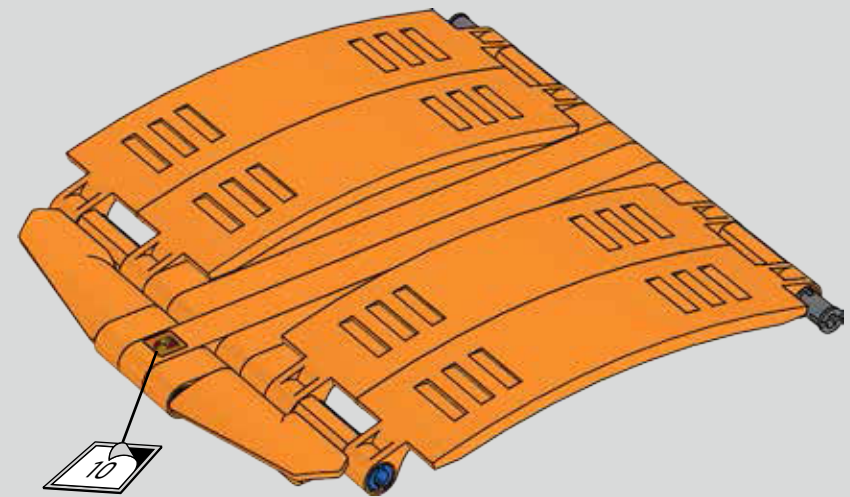
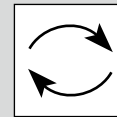

655

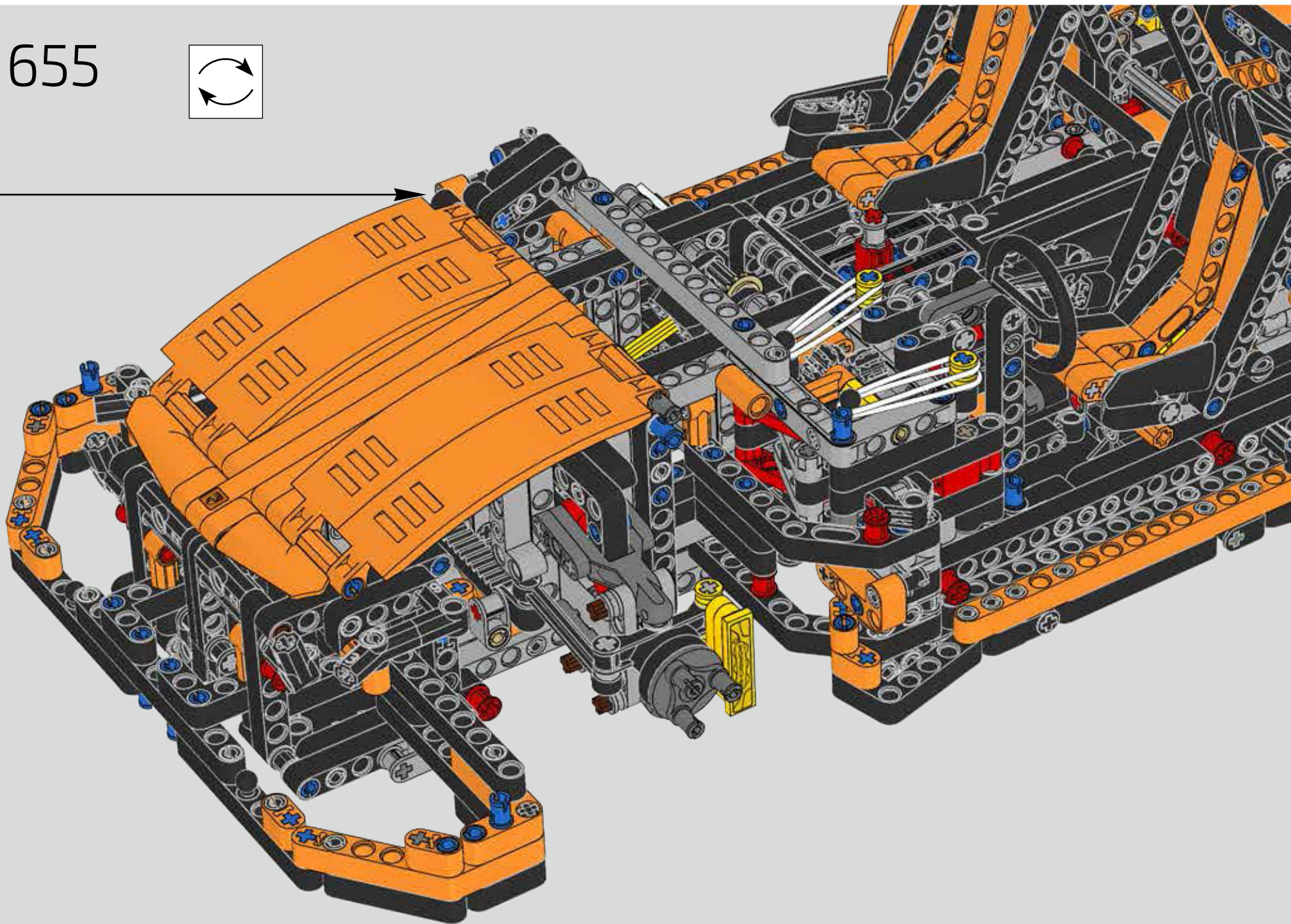
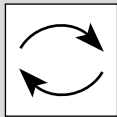

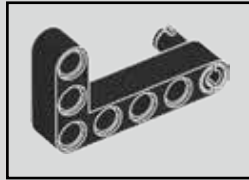
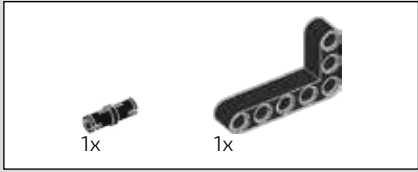

656

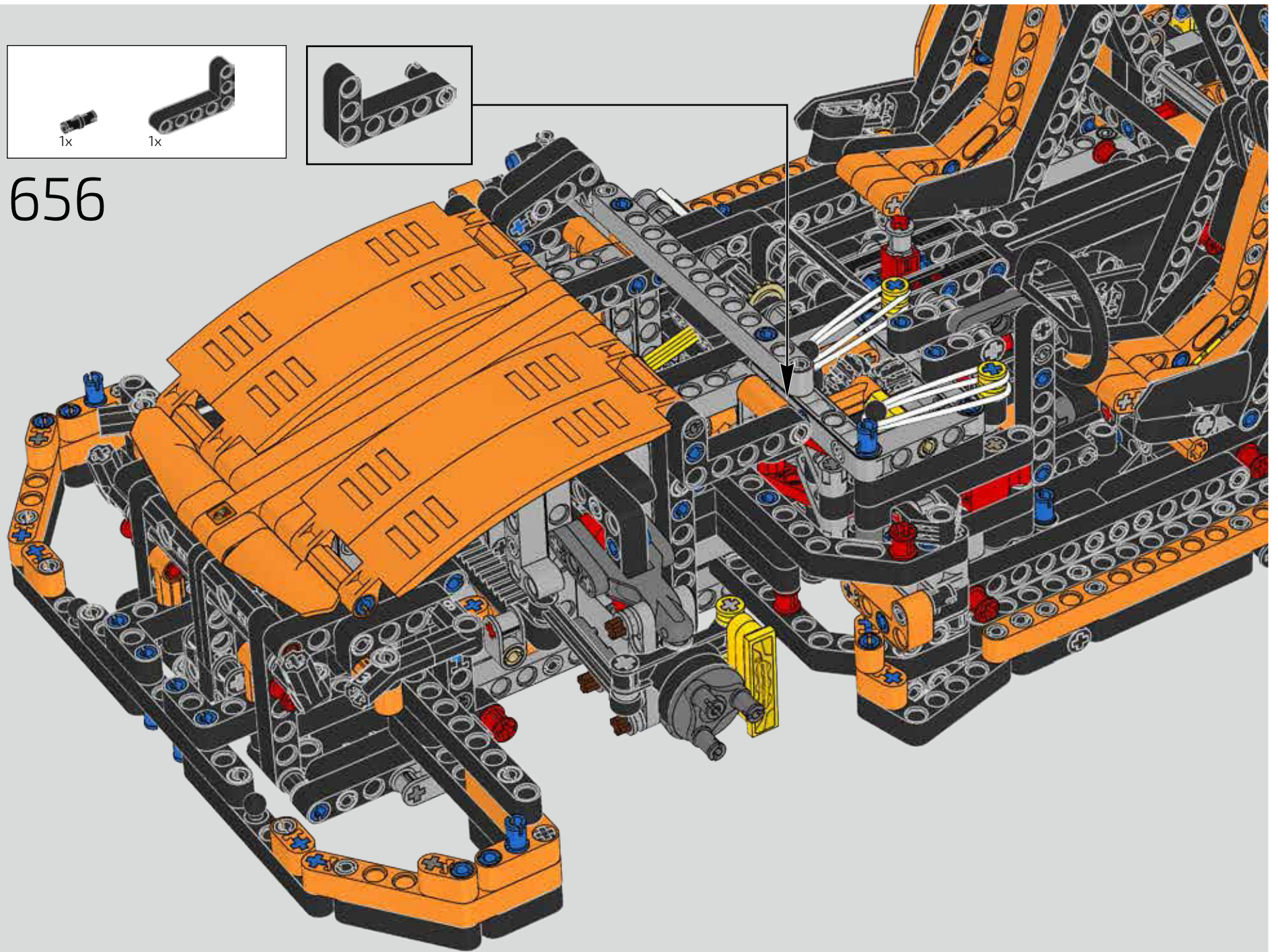

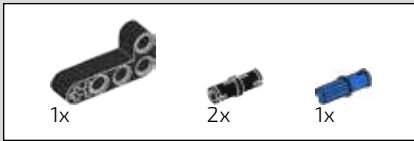

657



658

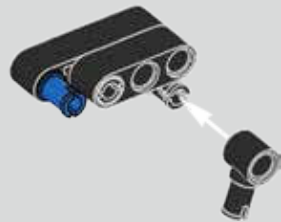

659

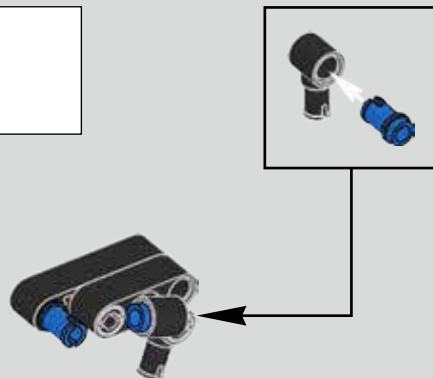

660



661

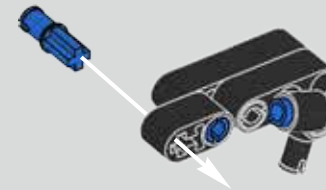

662

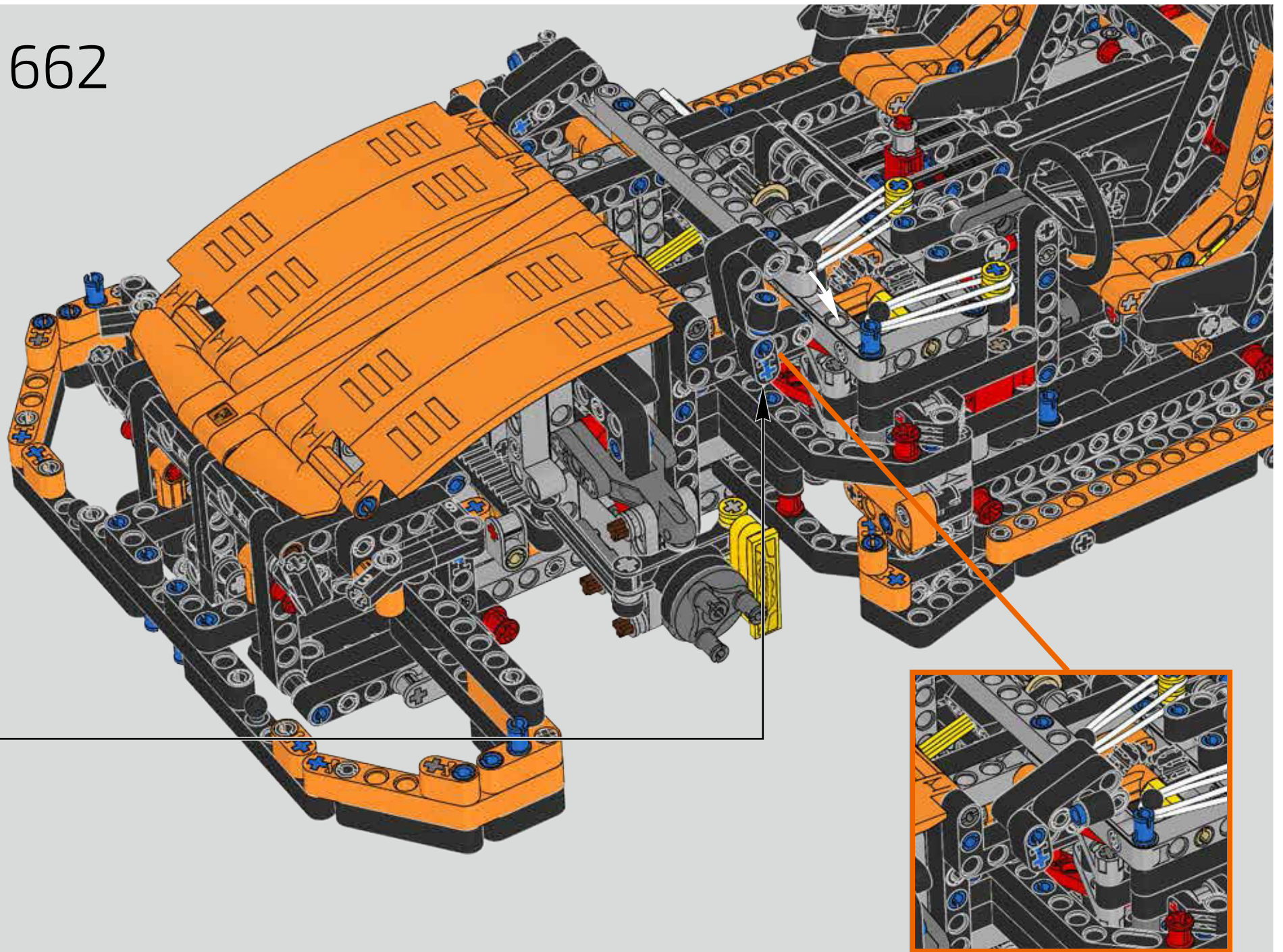

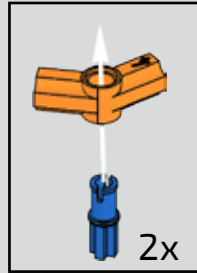

663

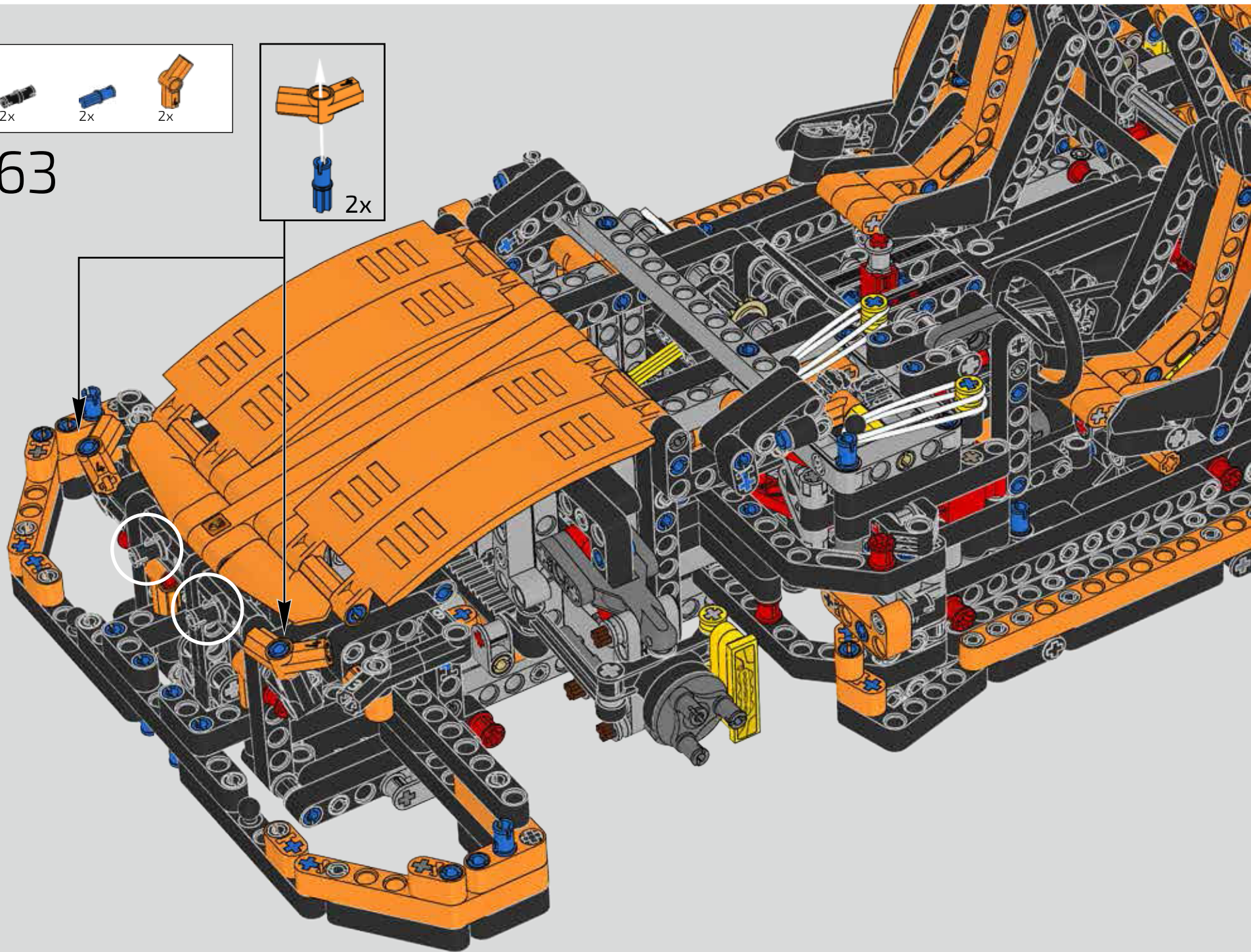

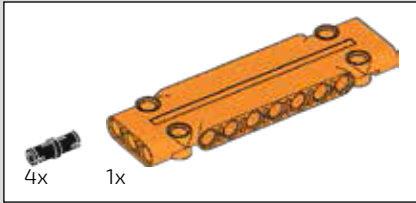
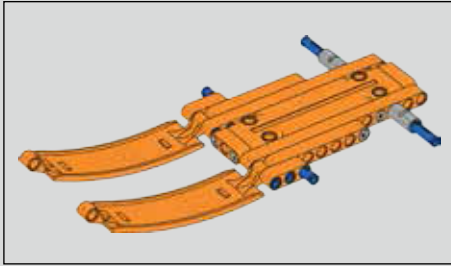

664

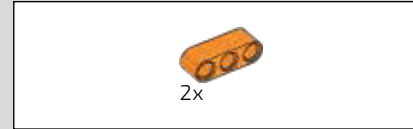
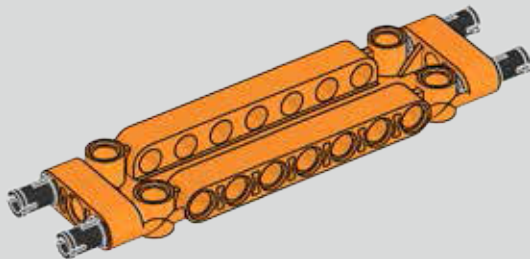

665

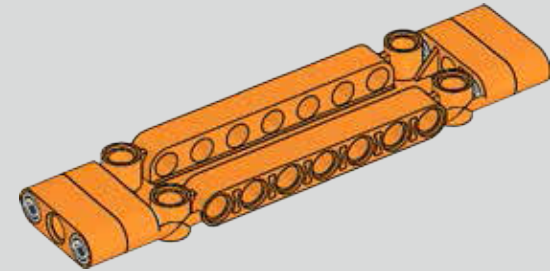

666

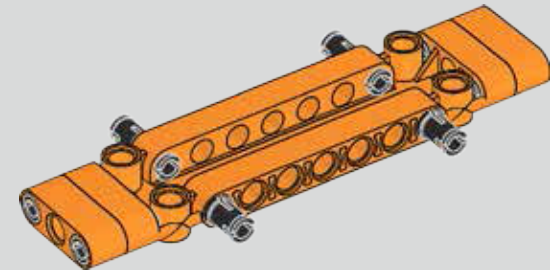

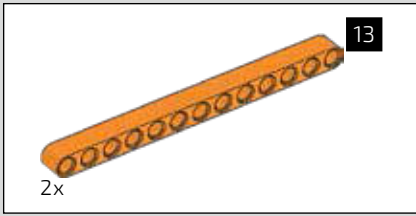

667

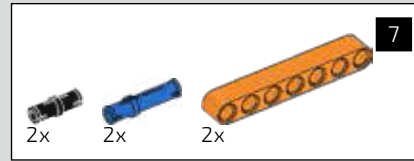
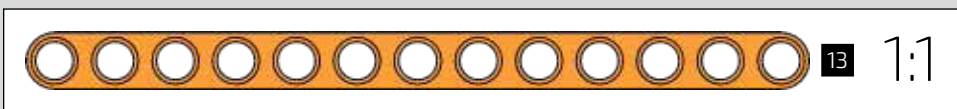
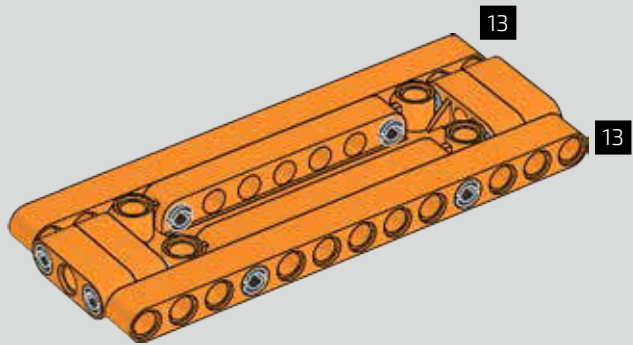

668

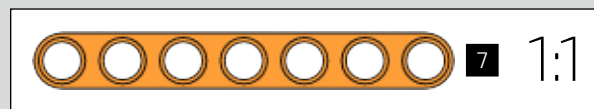
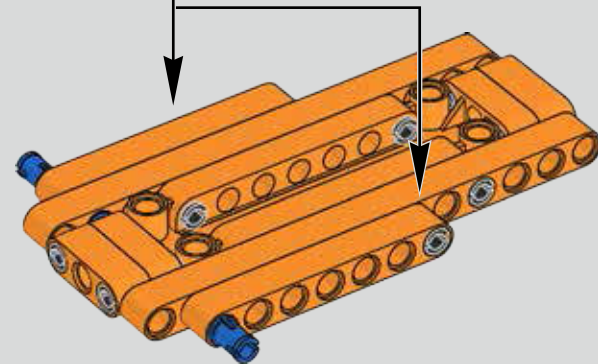
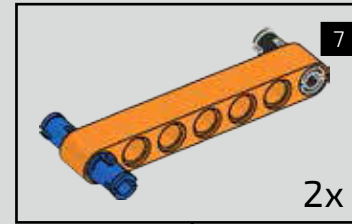

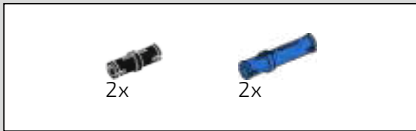

669

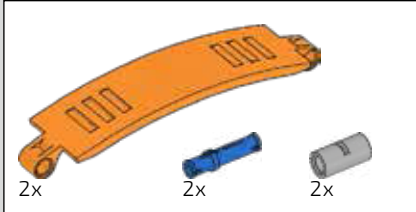
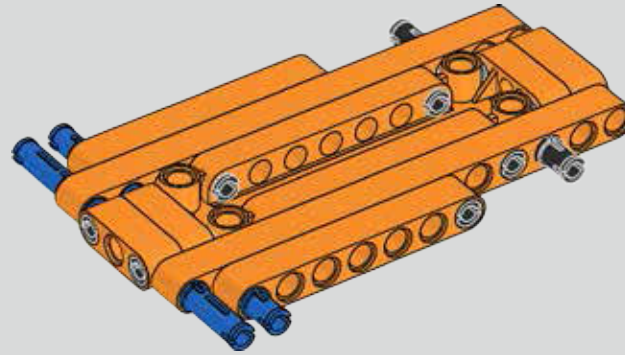

670

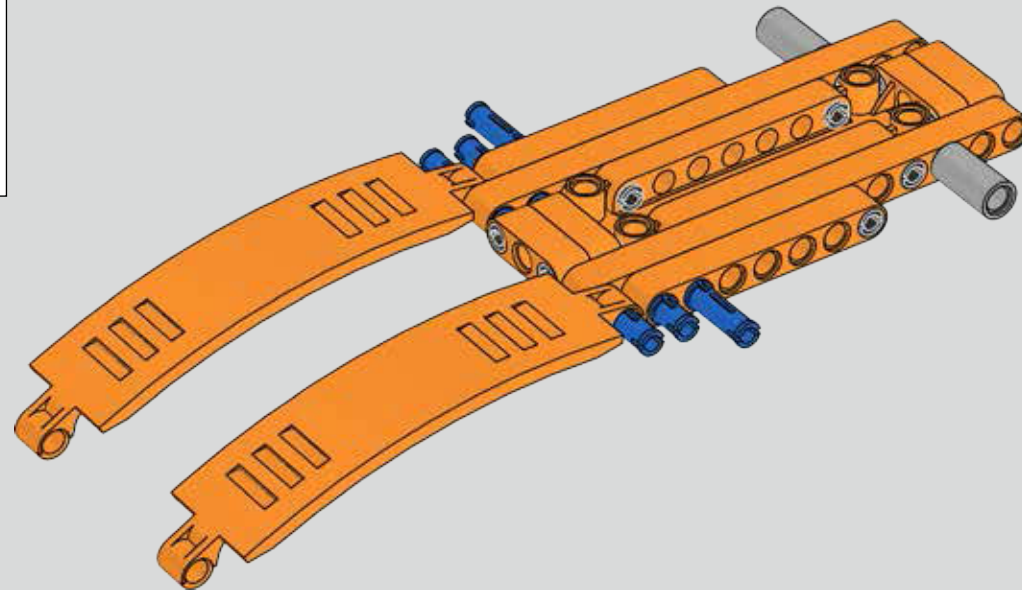

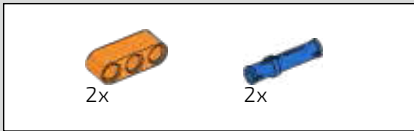

671

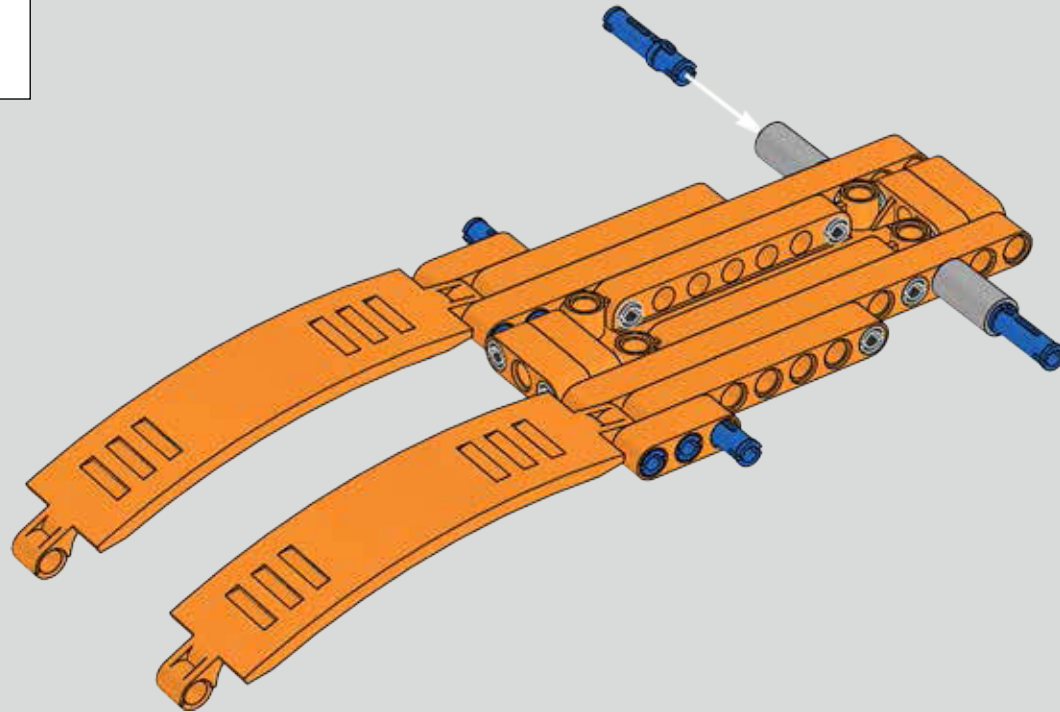

672

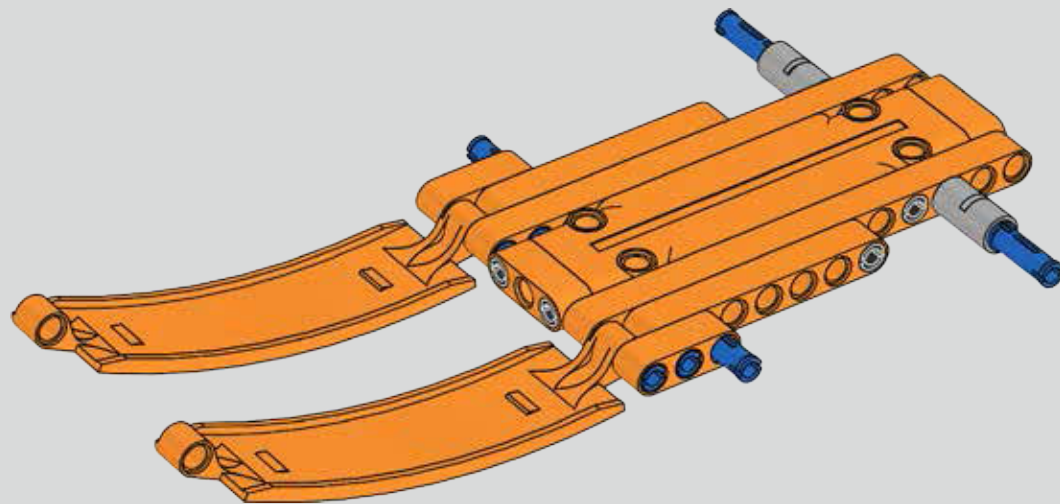
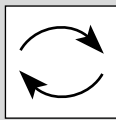



673

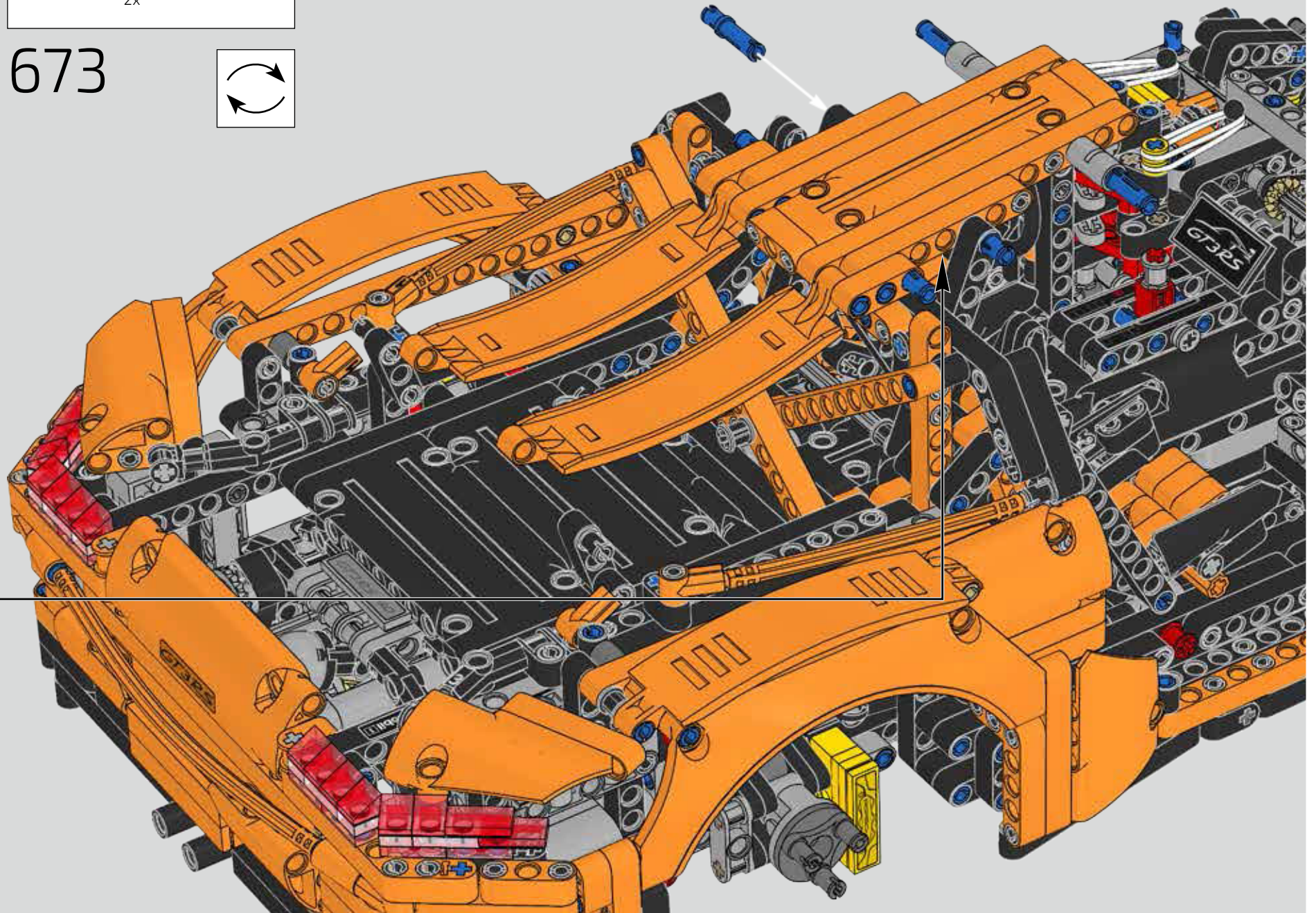
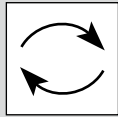



674

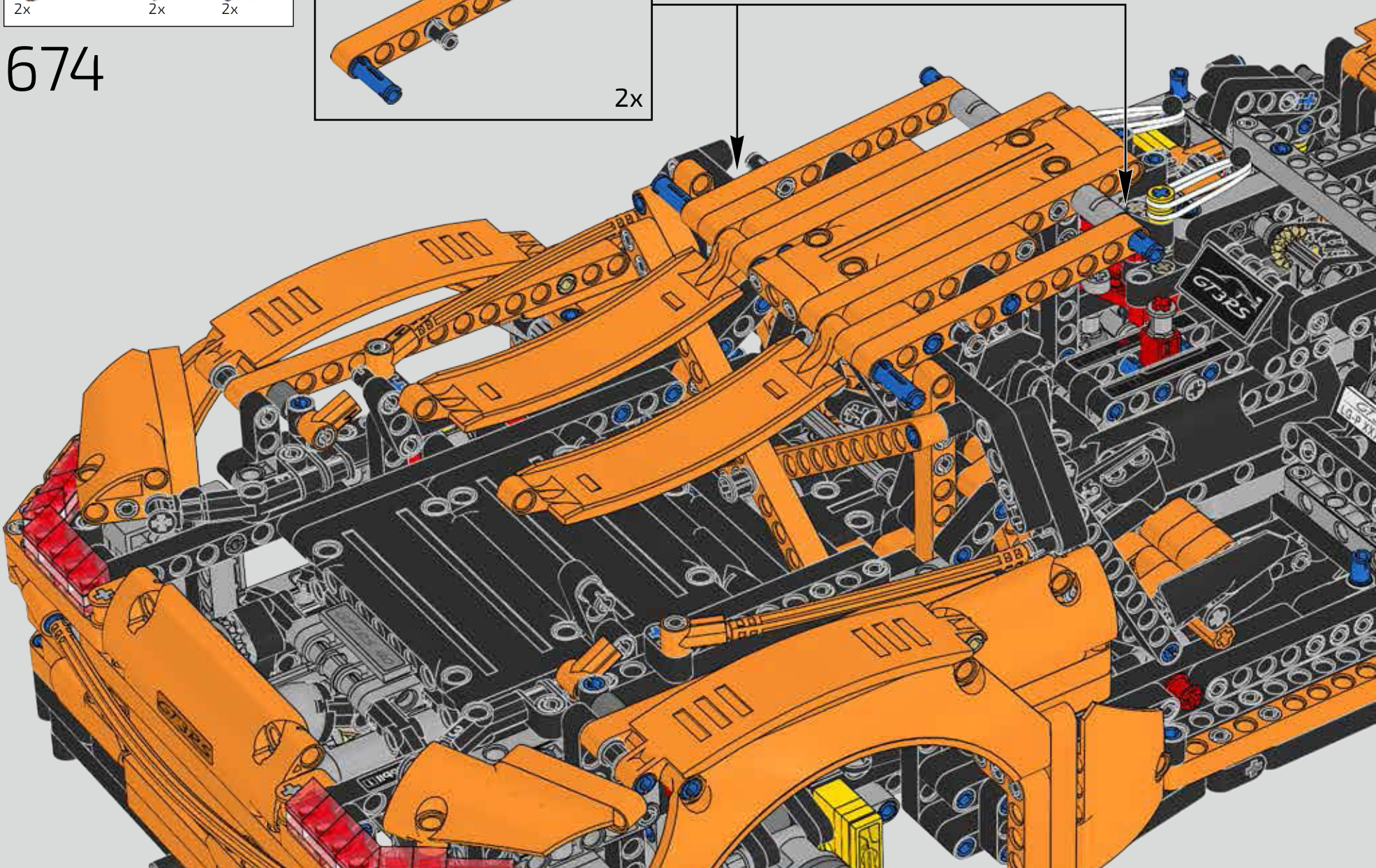
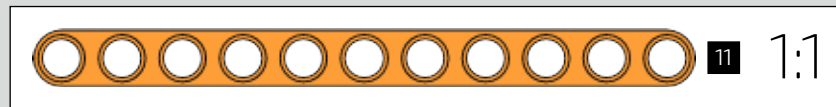
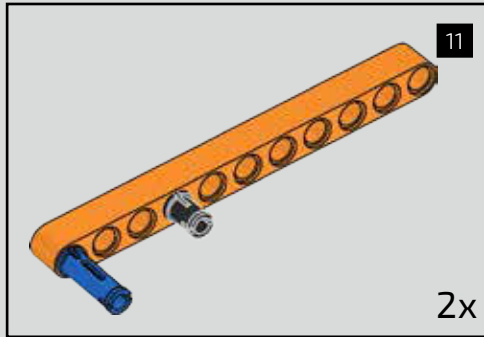

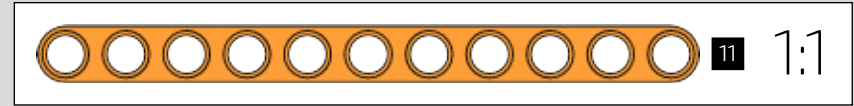
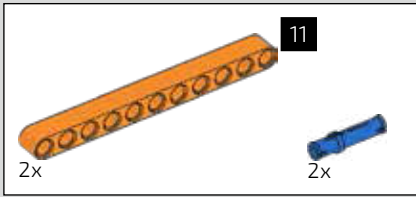

675

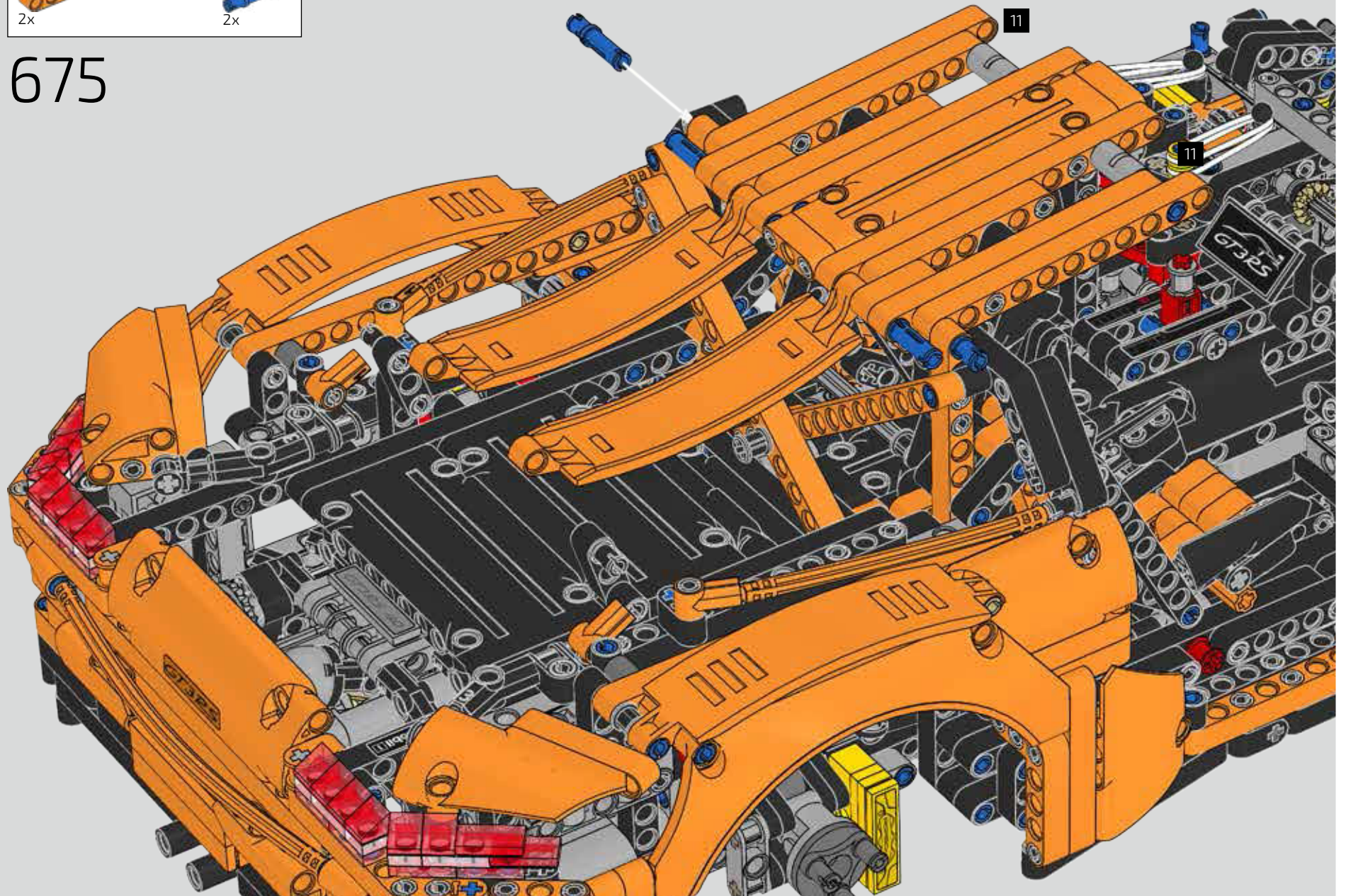



676

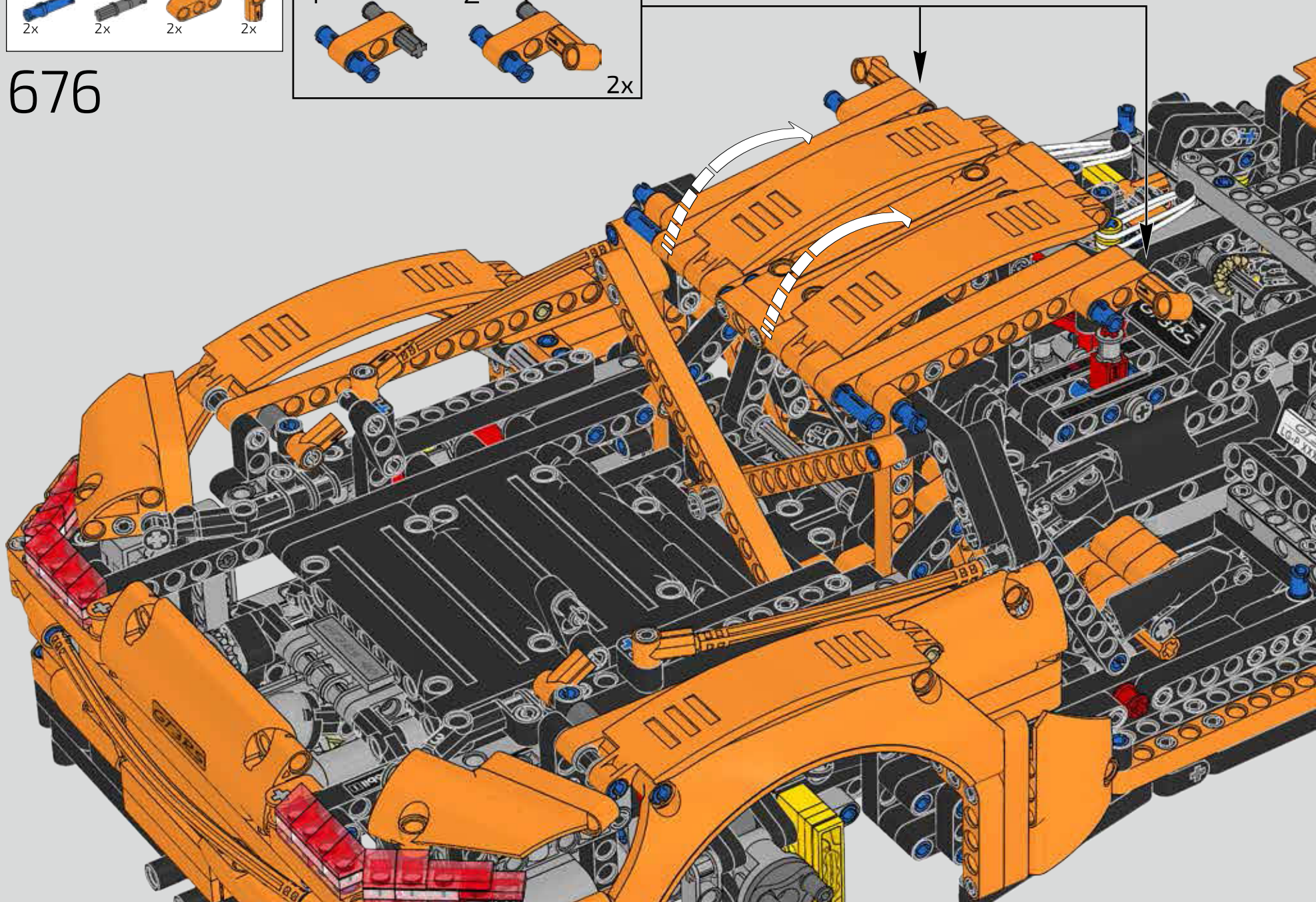
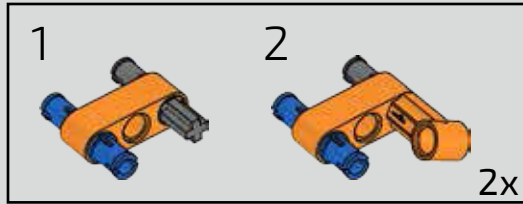

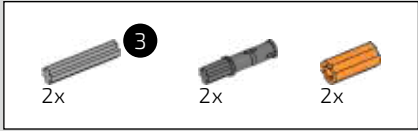

677

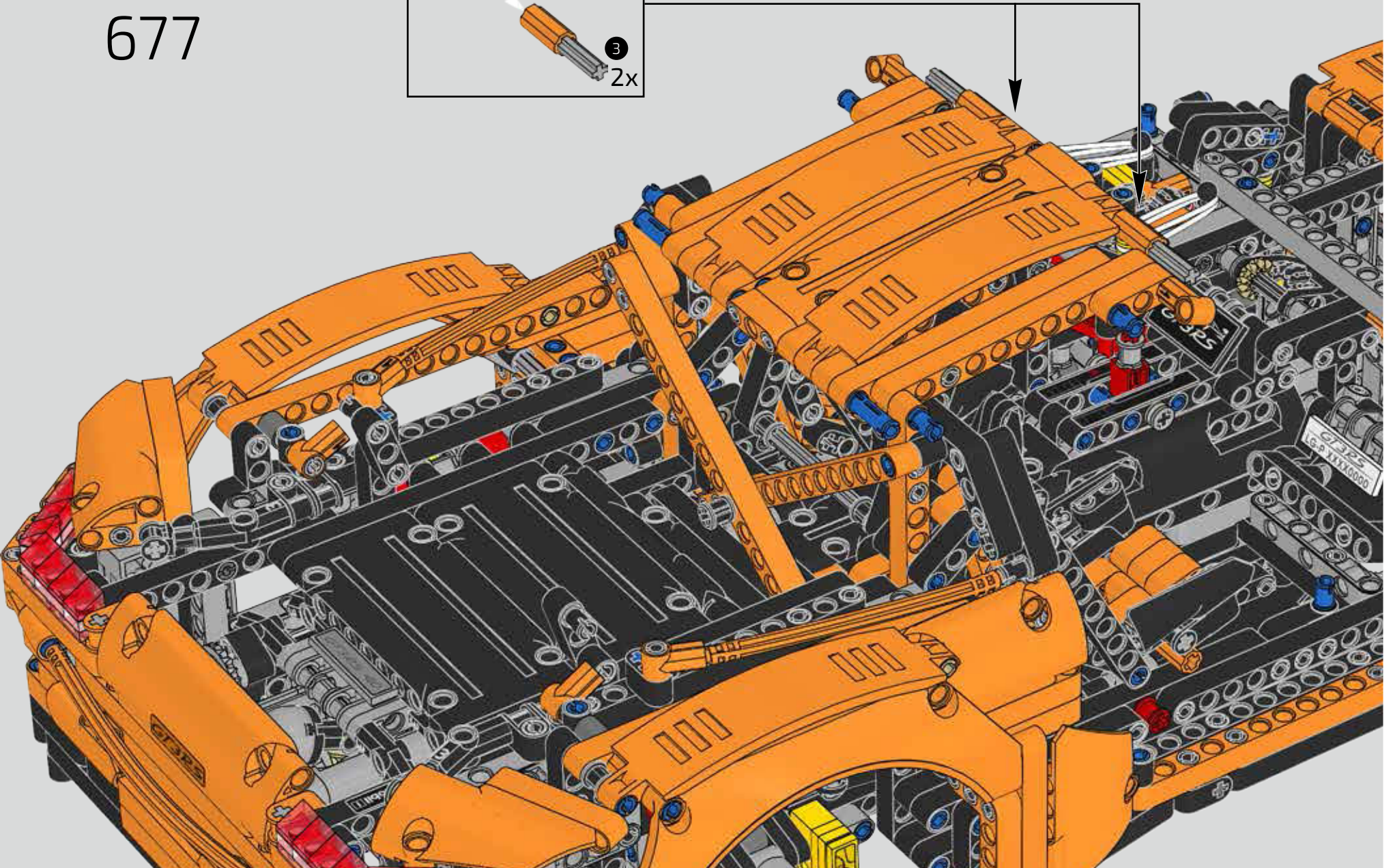
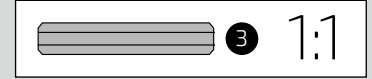
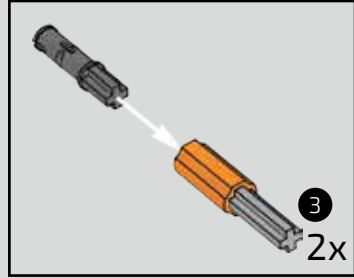

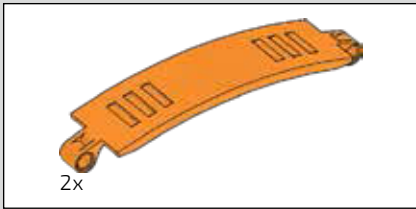

678

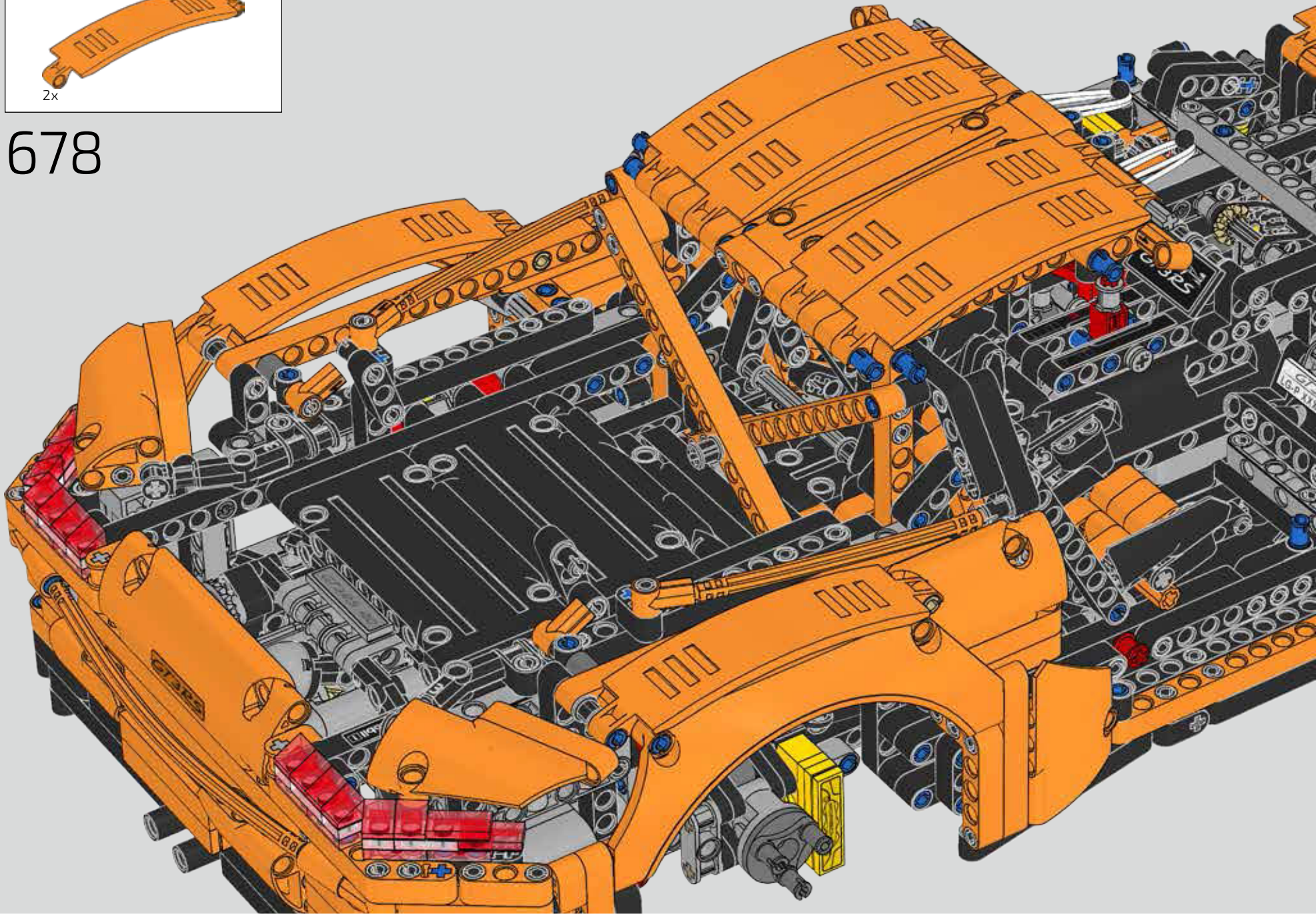

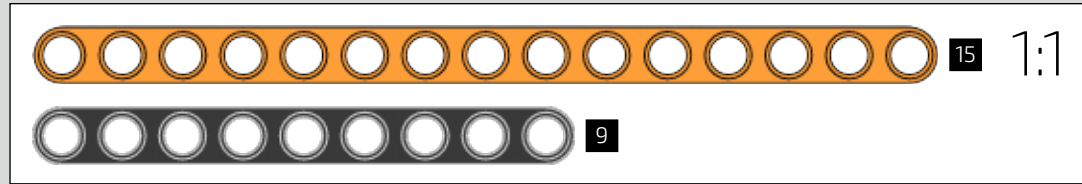
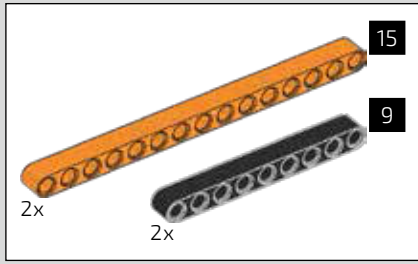

679

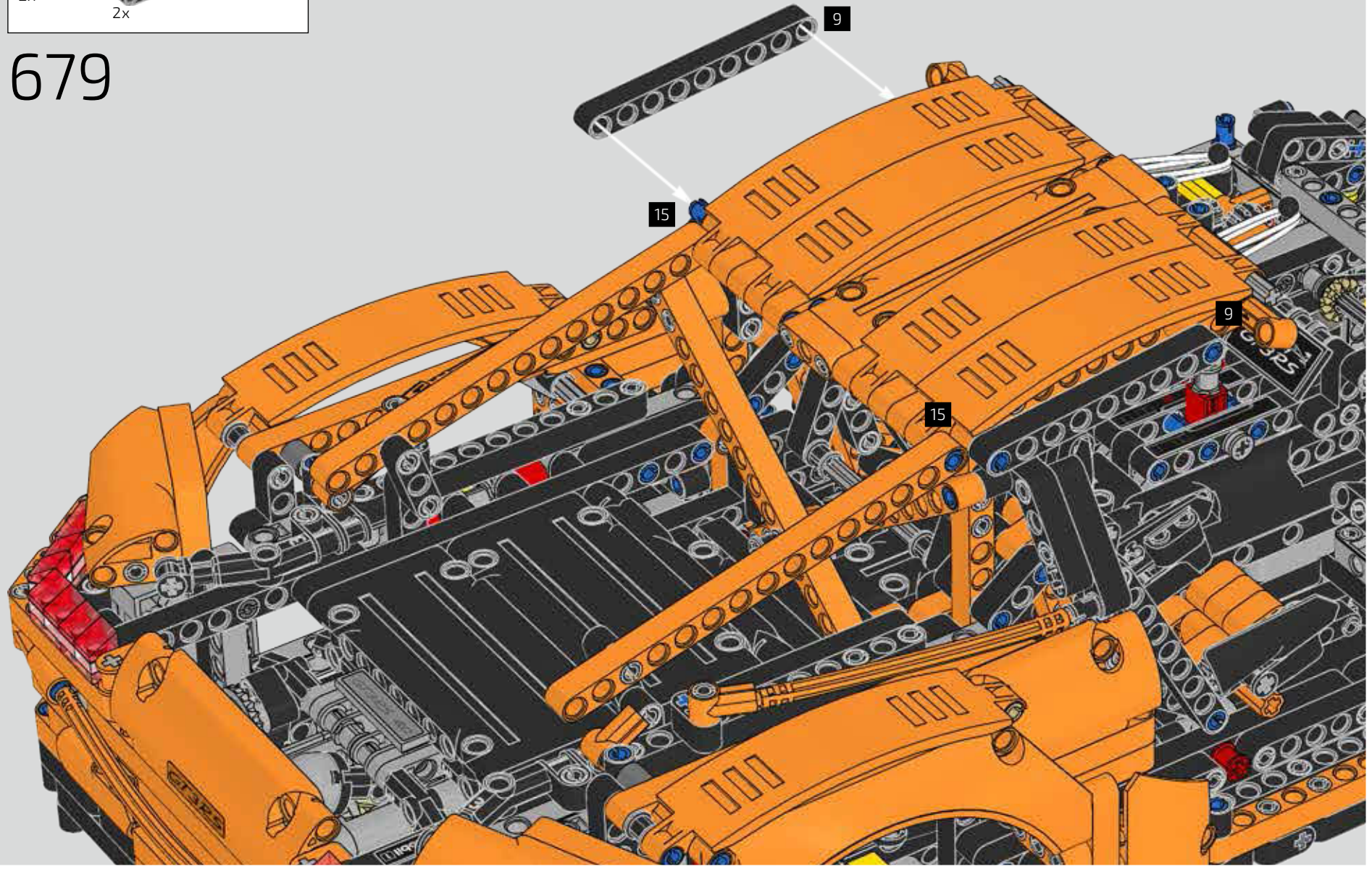



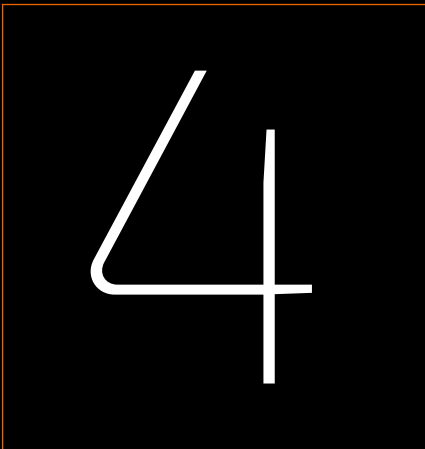

4

Now you build the front before adding the distinctive wheel arches with air outlets only found on the 911 GT3 RS. Next you add the massive, motorsport inspired, adjustable rear wing before finishing off your 911 GT3 RS by adding the doors and the exclusive wheels.

Vous construisez maintenant l'avant, avant d'ajouter les passages de roue caractéristiques avec des prises d'air présentes uniquement sur la 911 GT3 RS. Ajoutez ensuite l'aile arrière énorme et ajustable d'inspiration sportive avant de terminer votre 911 GT3 RS en ajoutant les portes et les roues exclusives.



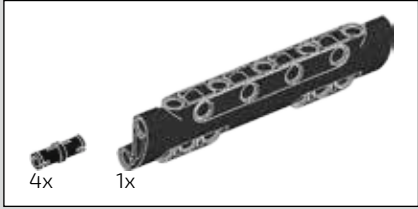
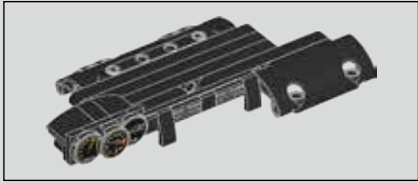

680

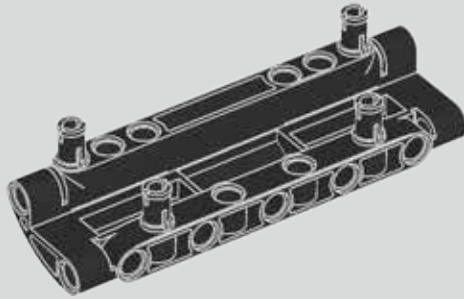

681

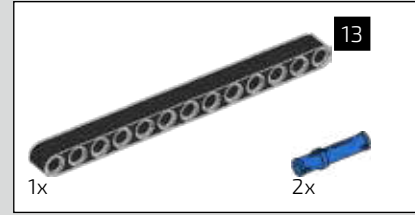
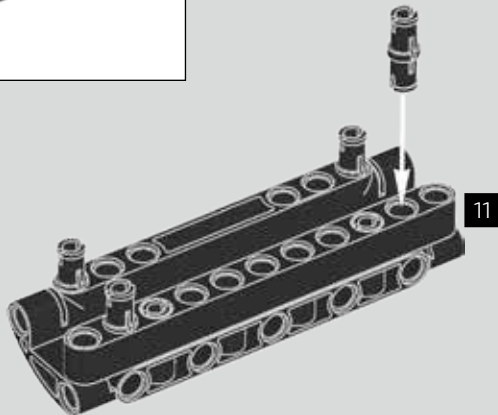

682

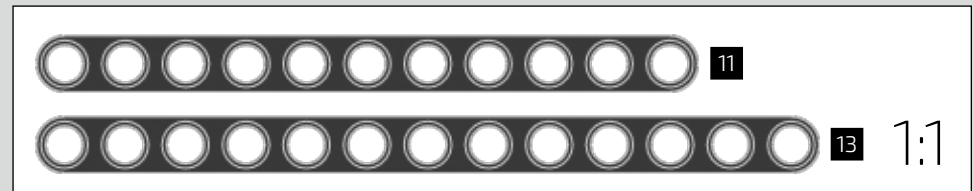
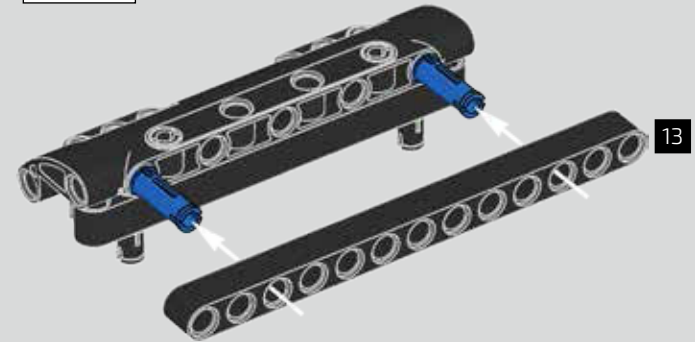
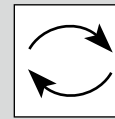

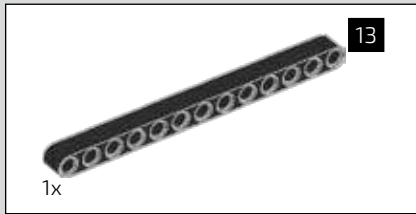

683

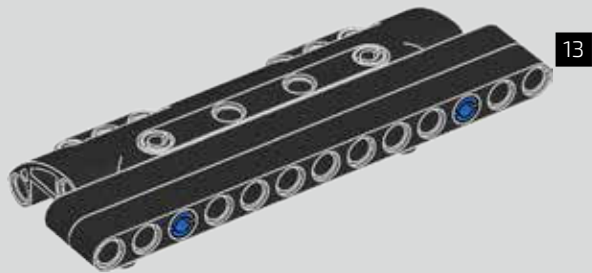

684

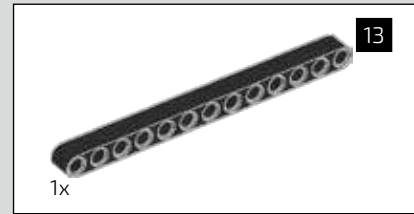
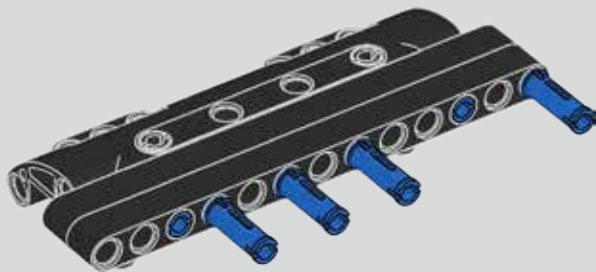

685

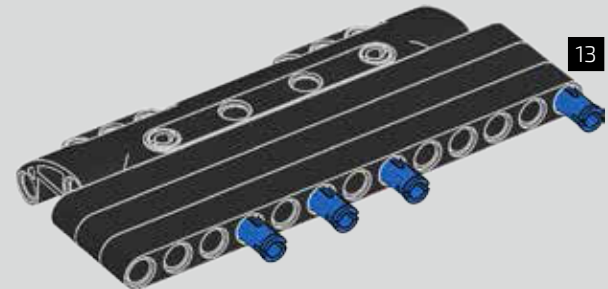

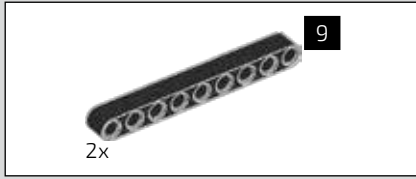

686

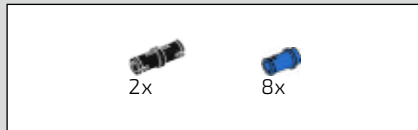
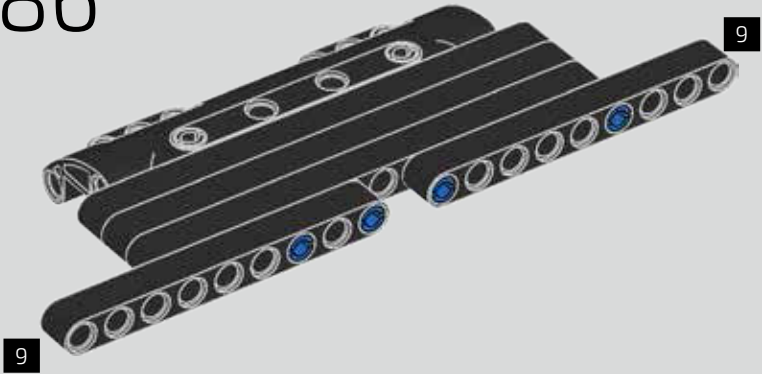

687

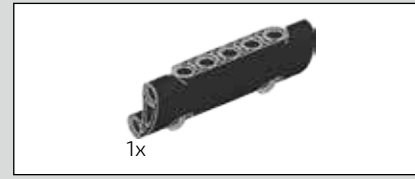
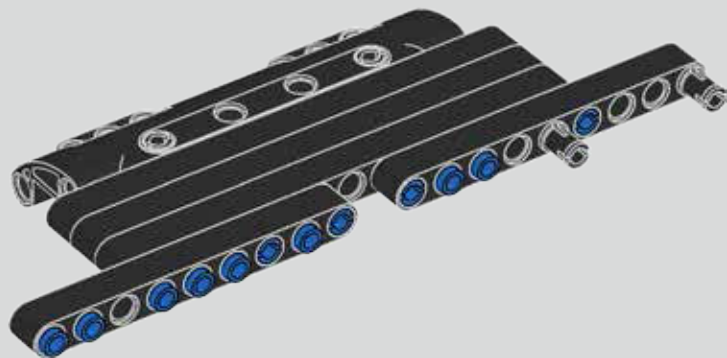

688

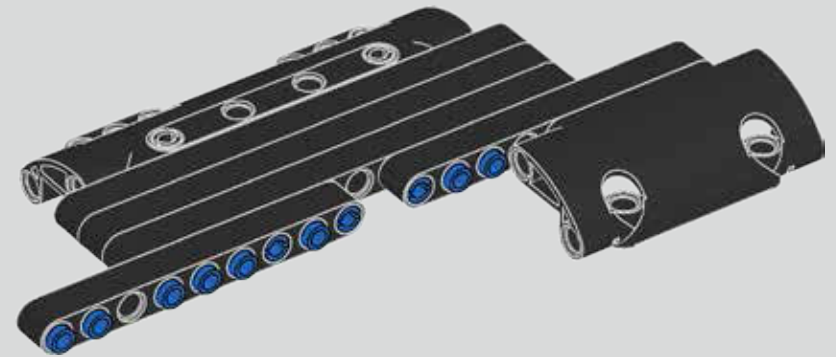

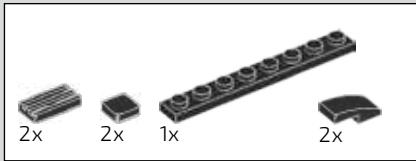

689

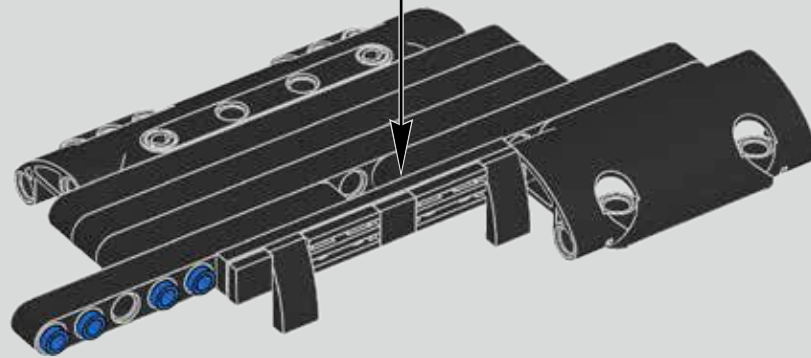
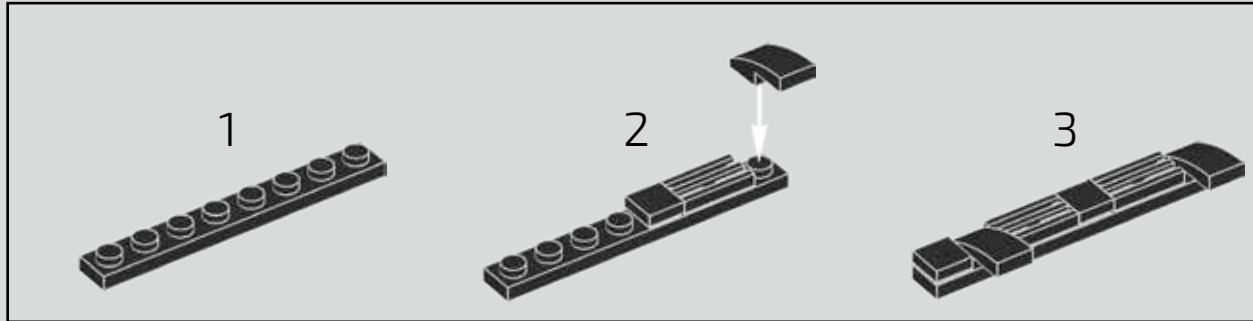

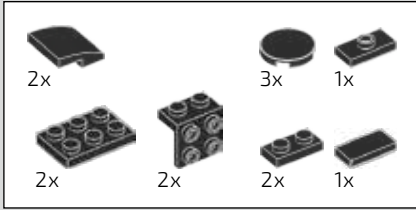

690

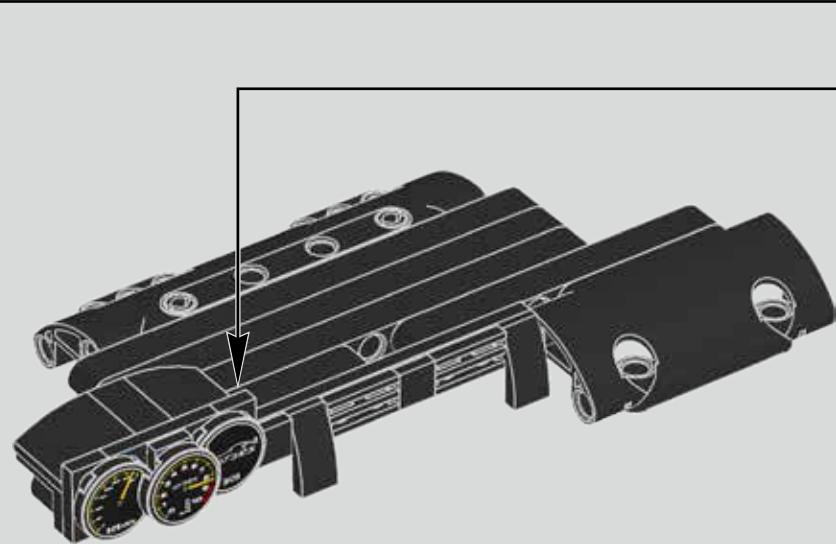
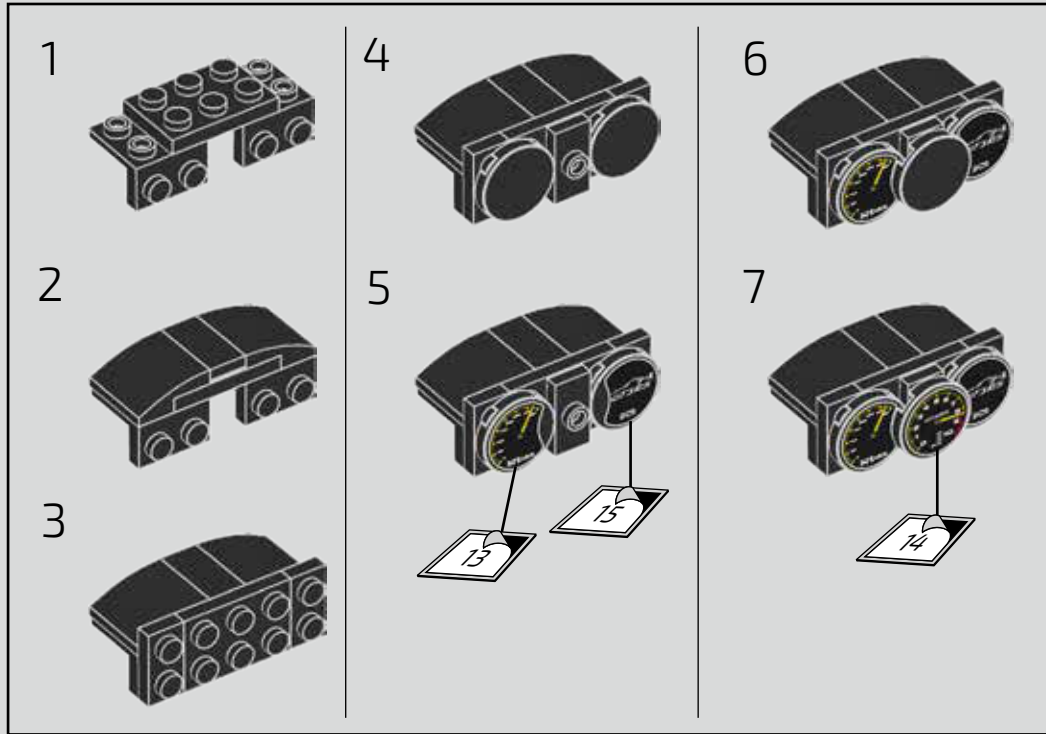

691

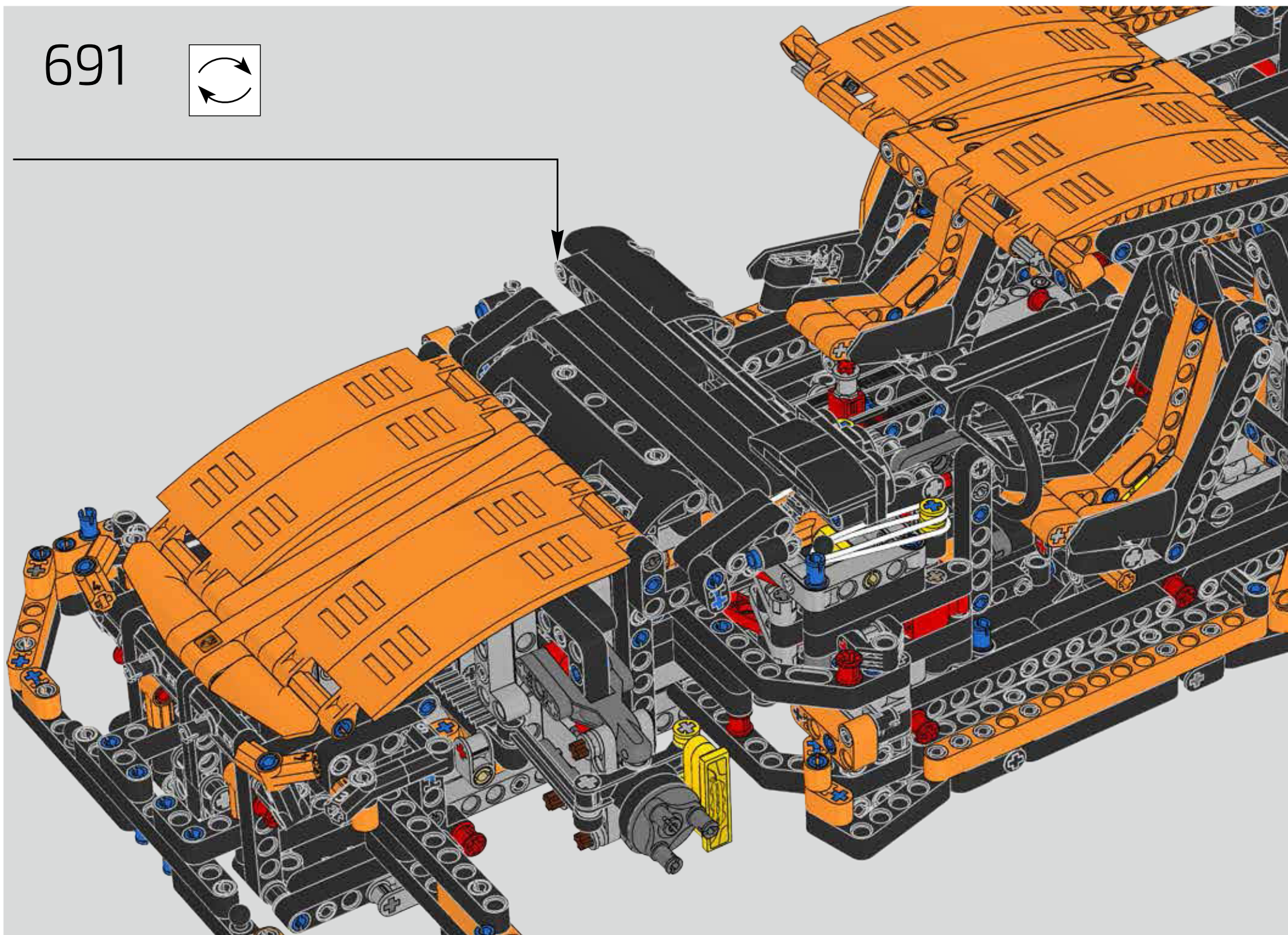
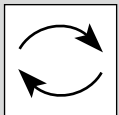

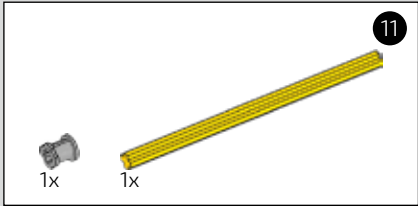
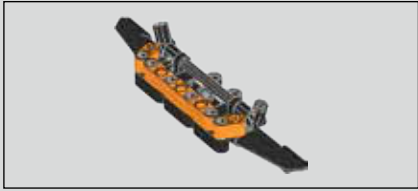

692

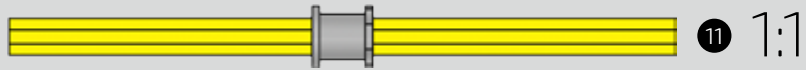

693

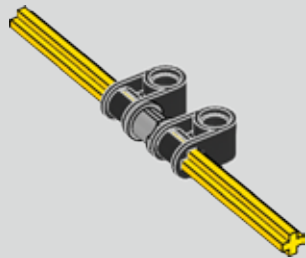

694

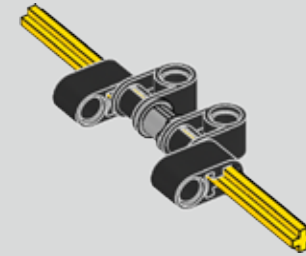

695

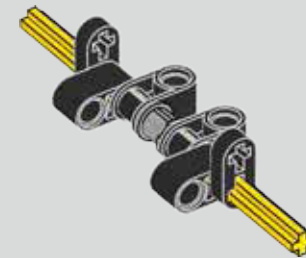



696

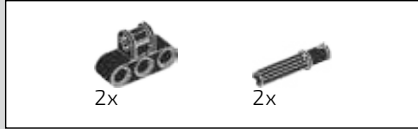
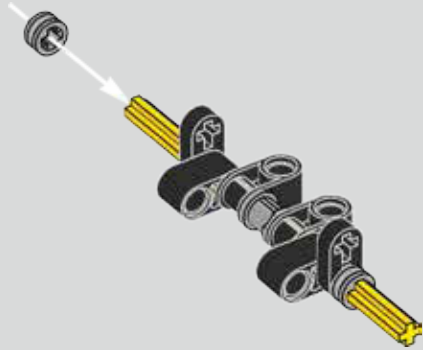

697

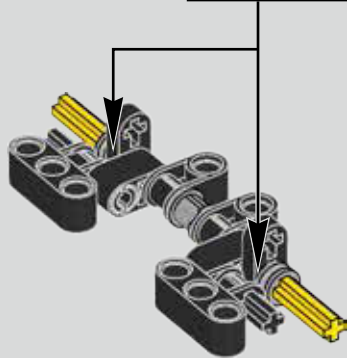
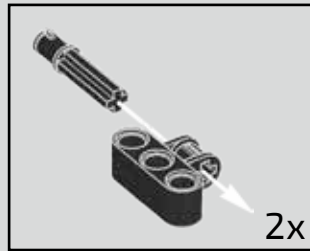

698

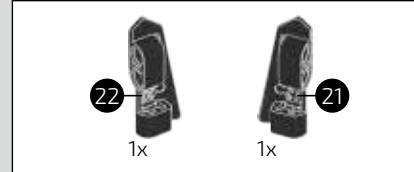
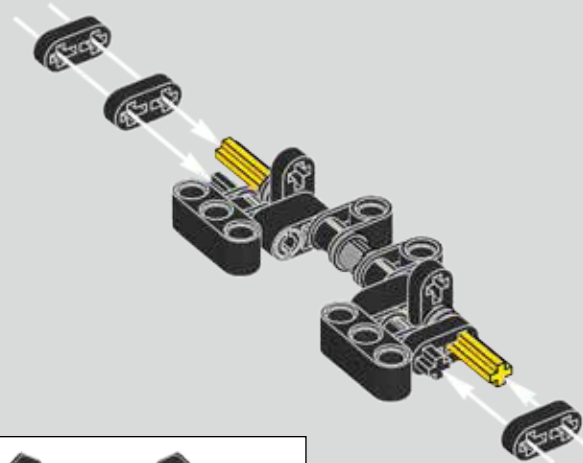

699

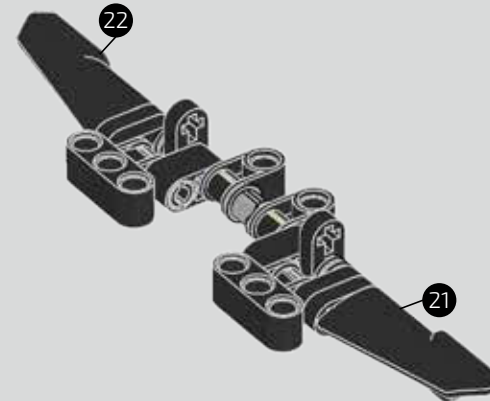

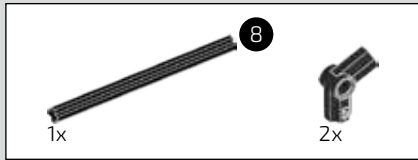

700

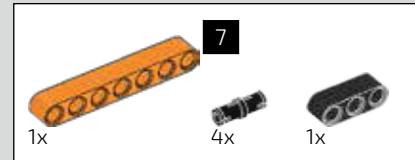
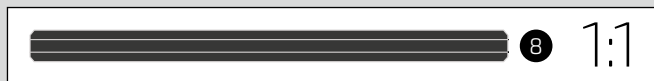
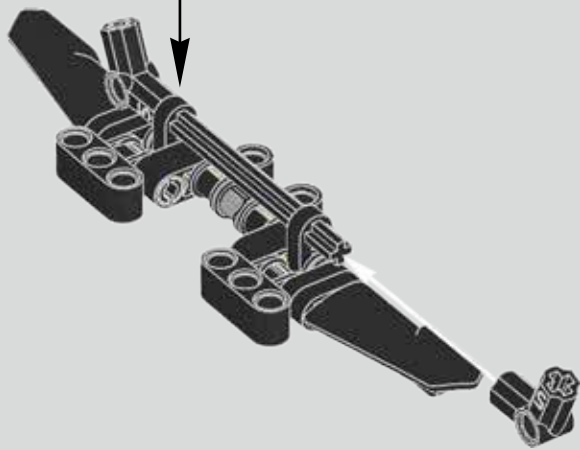
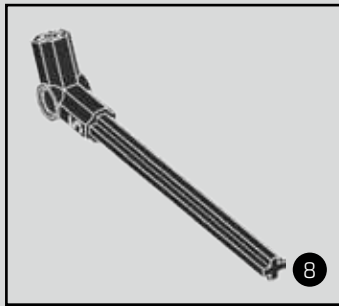

701

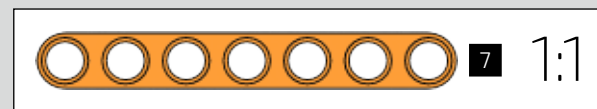
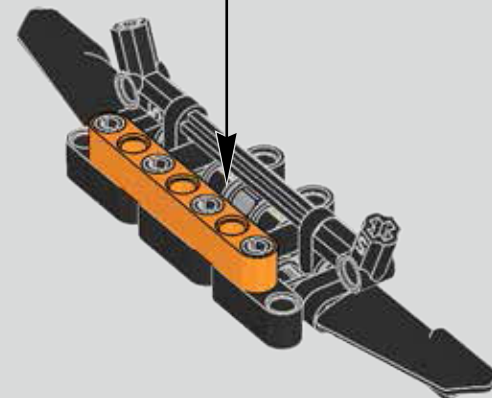
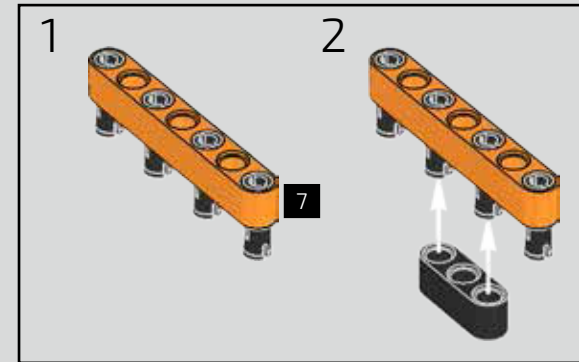



702

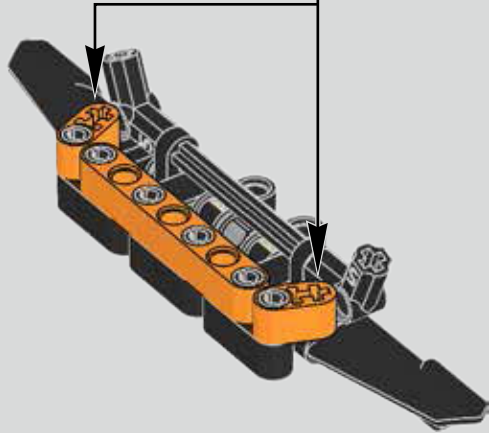
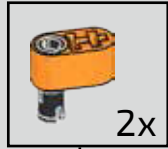

703

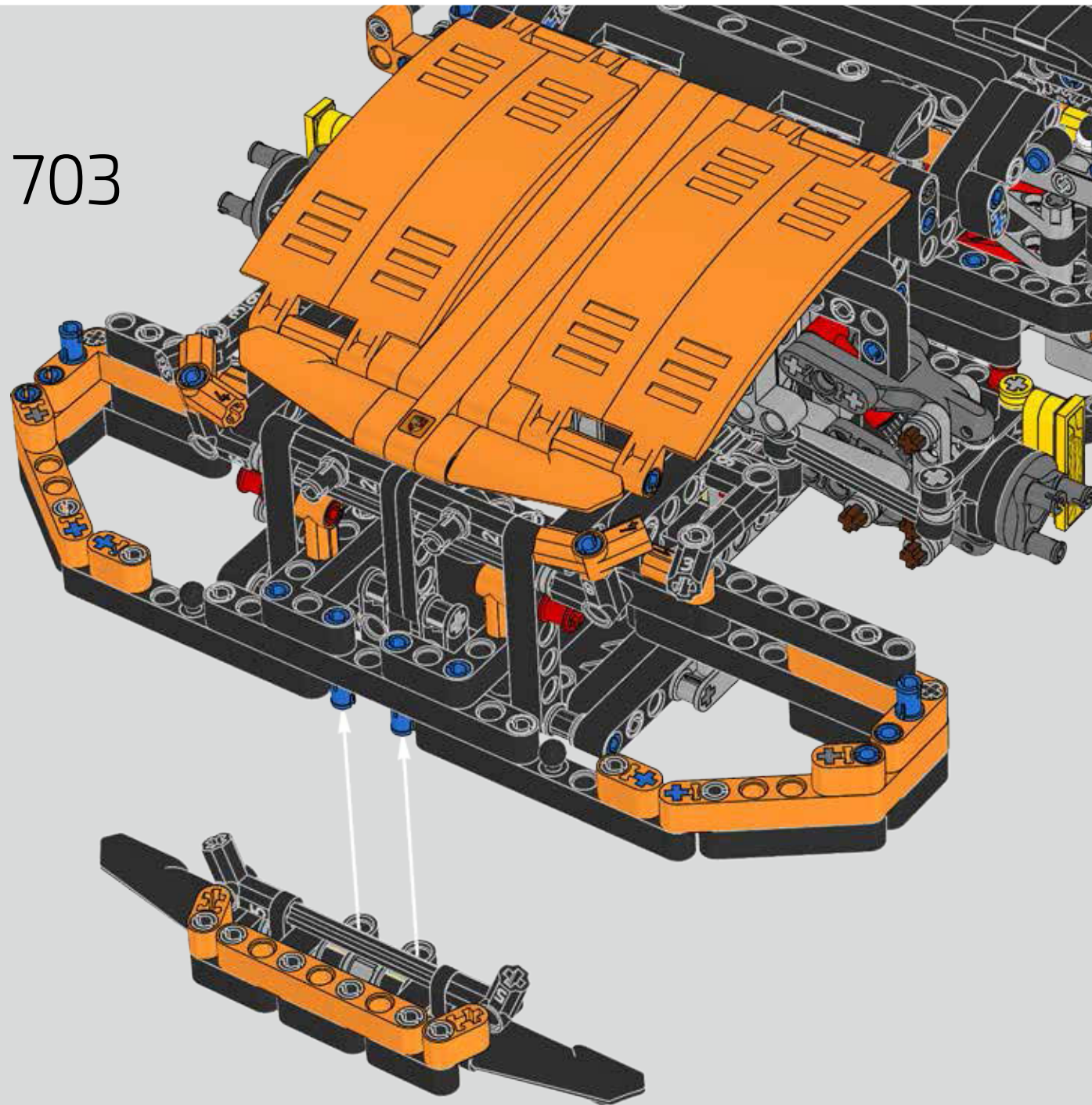

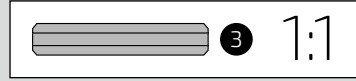
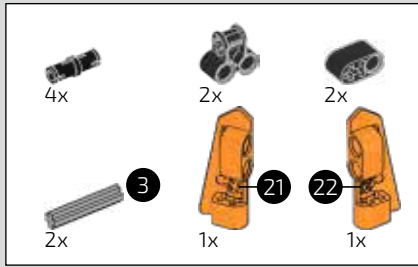

704

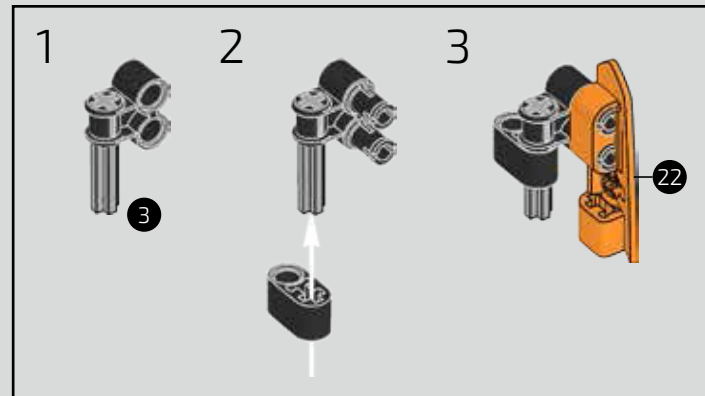
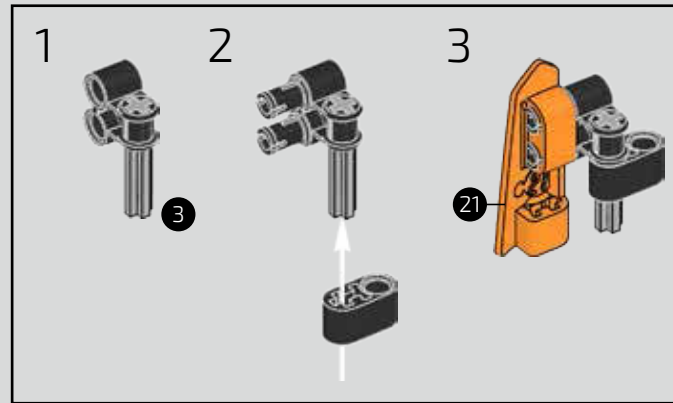

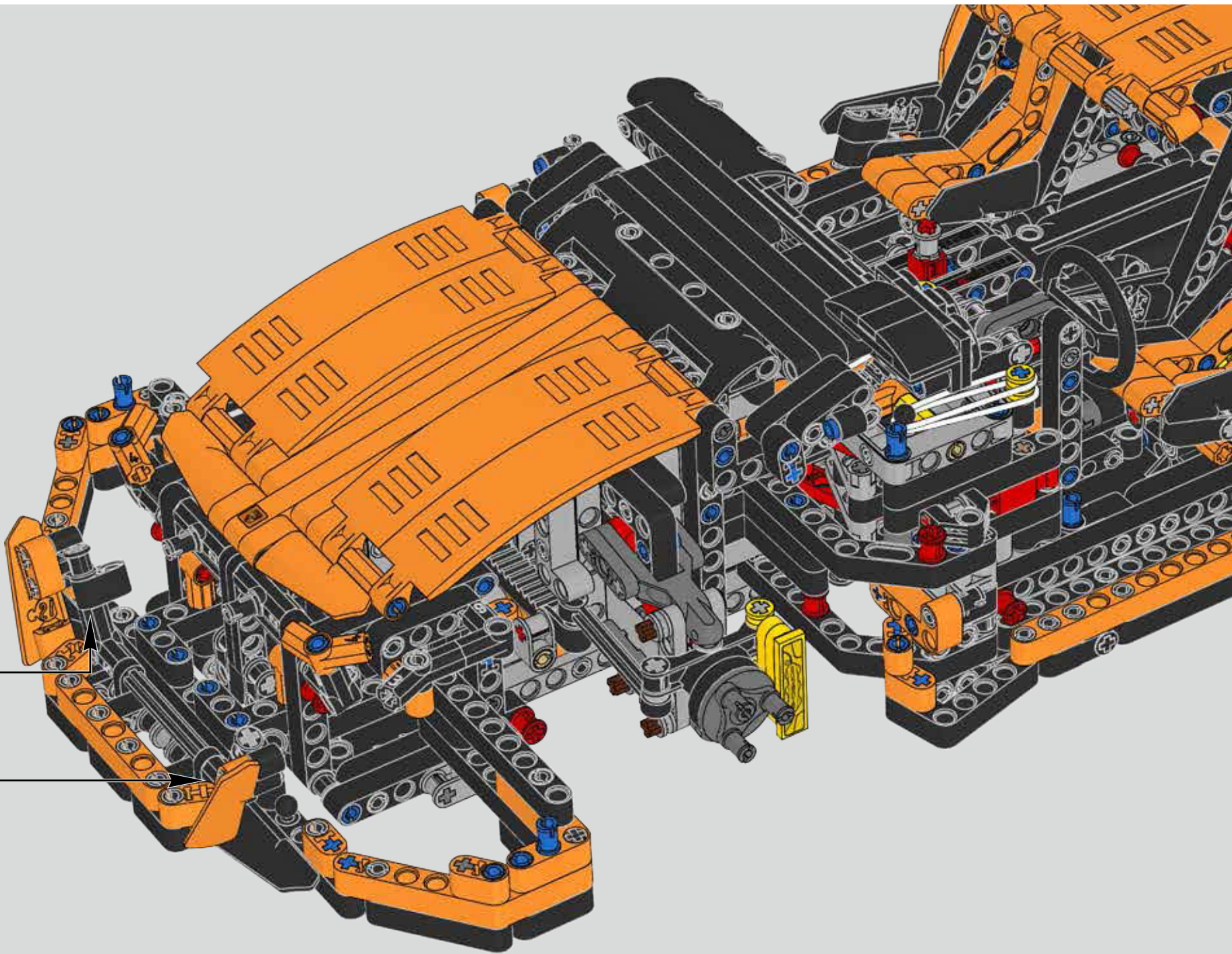

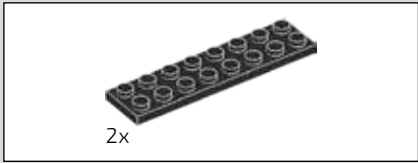
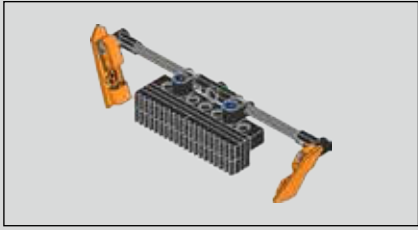

2x

705

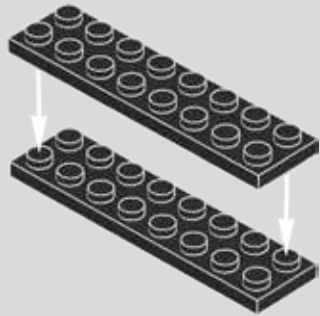

4x

706

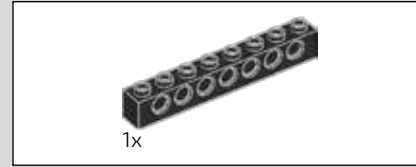
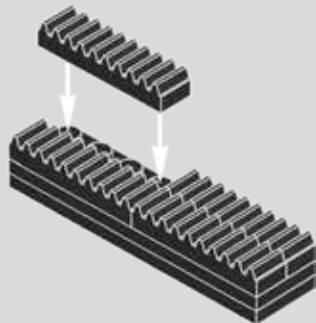

1x

707

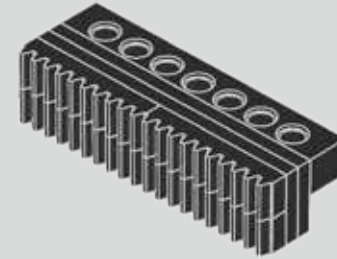
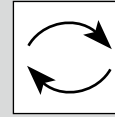

2x

708

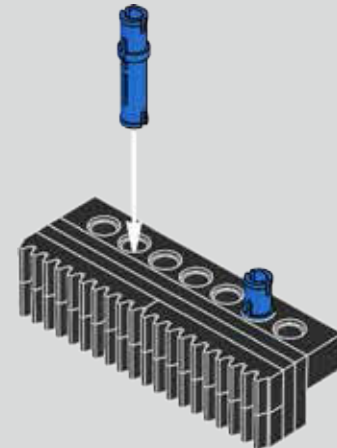

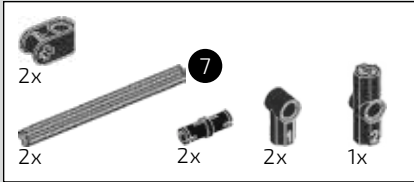

709

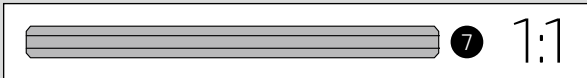
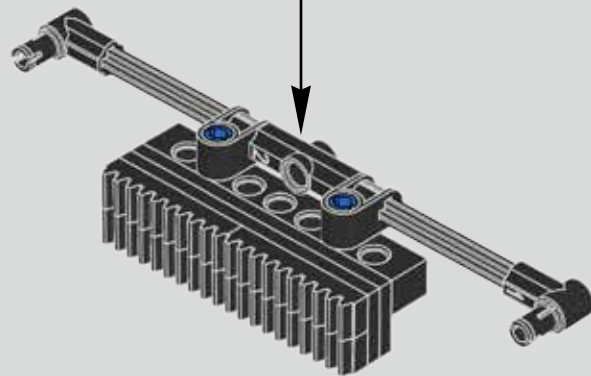
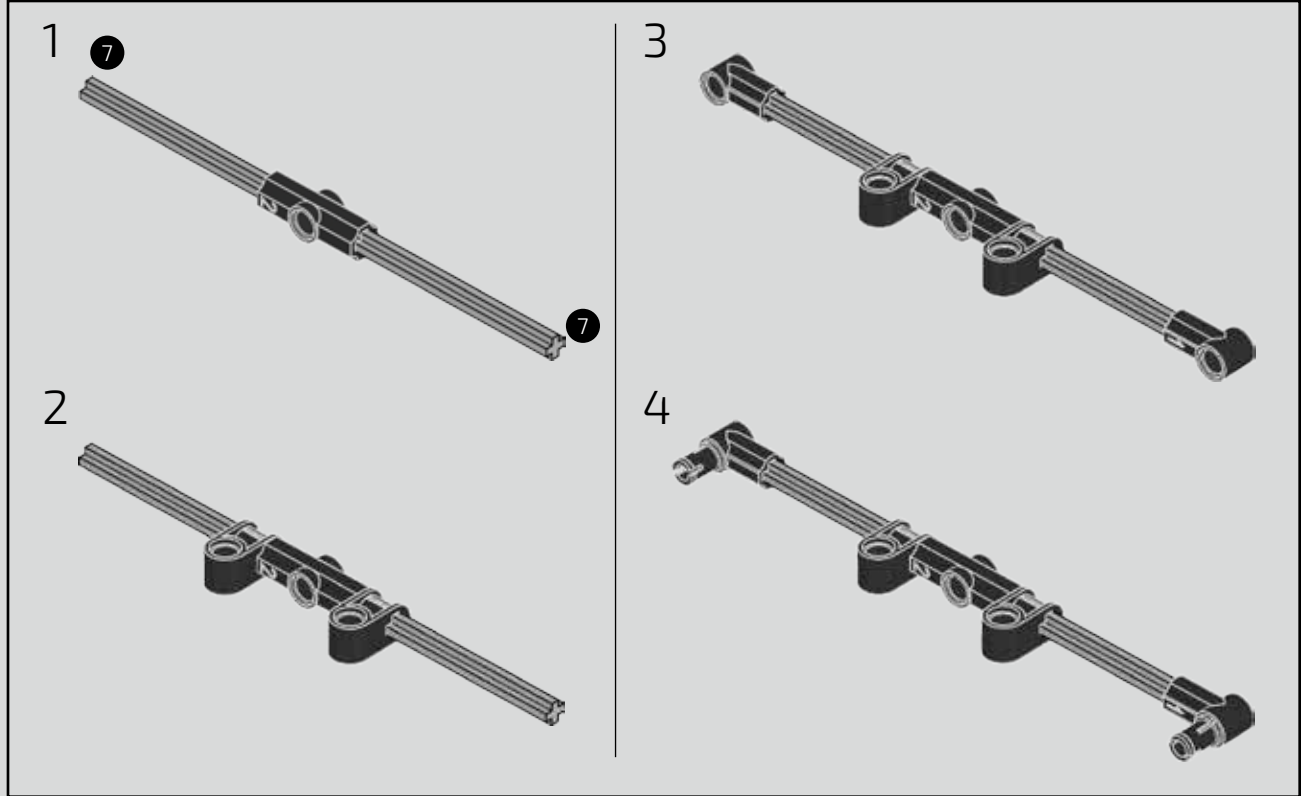

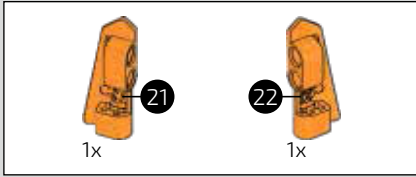

710

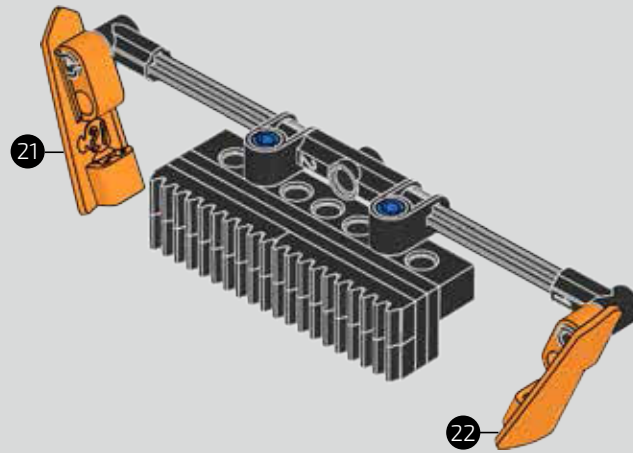

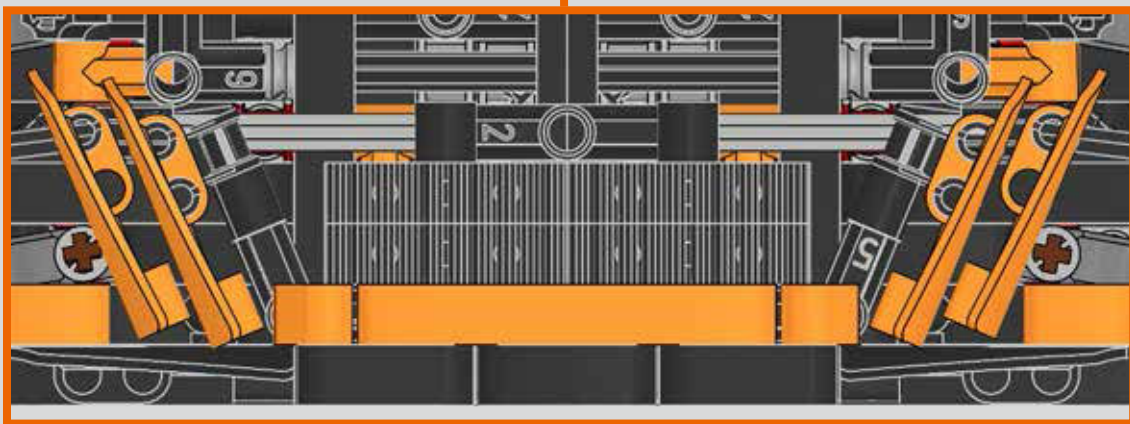
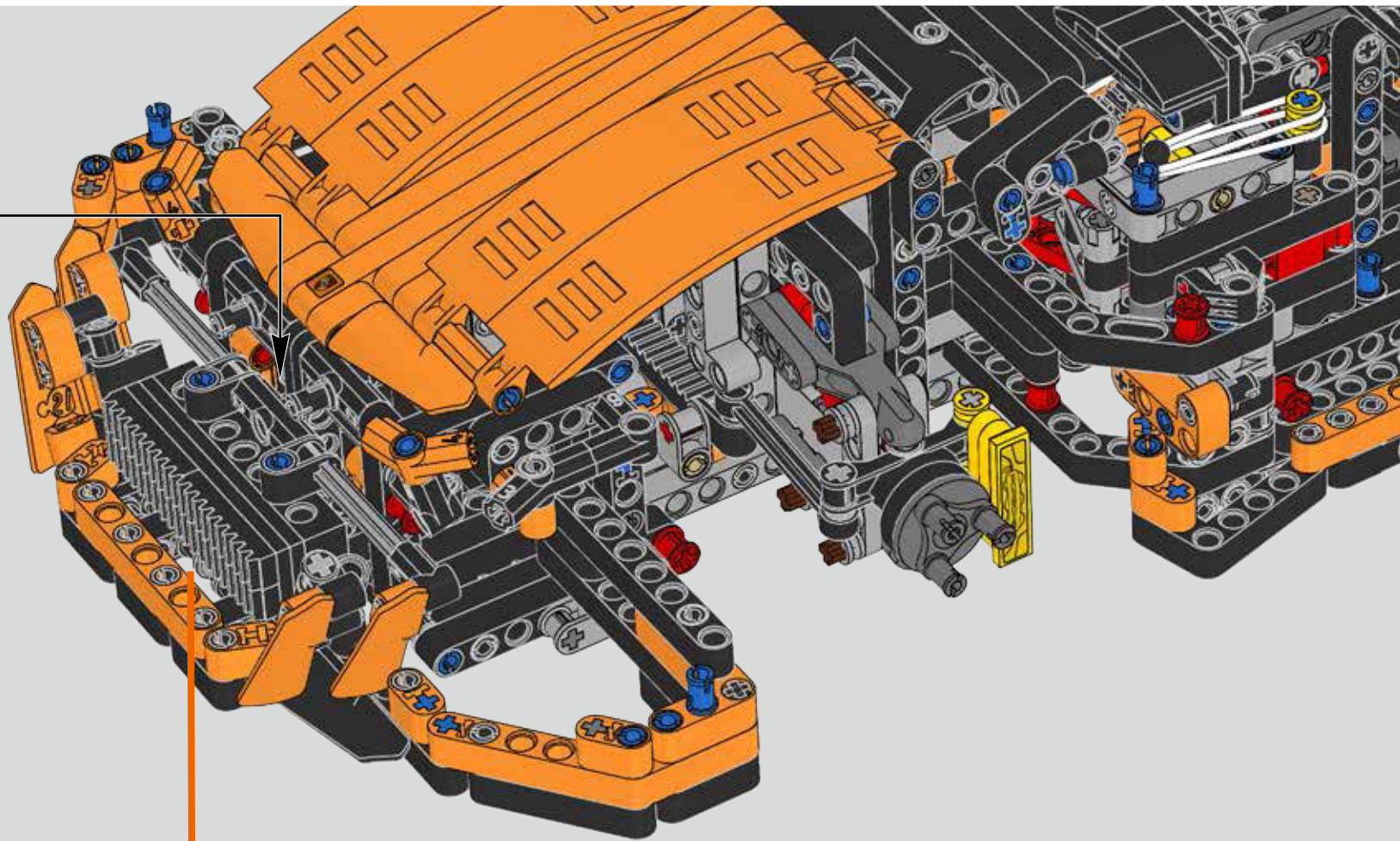

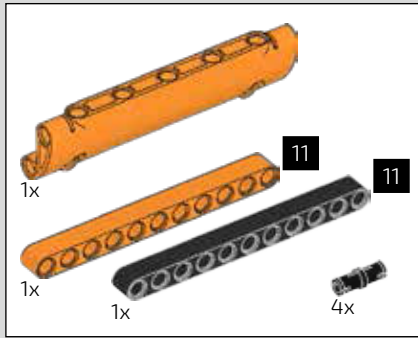

711

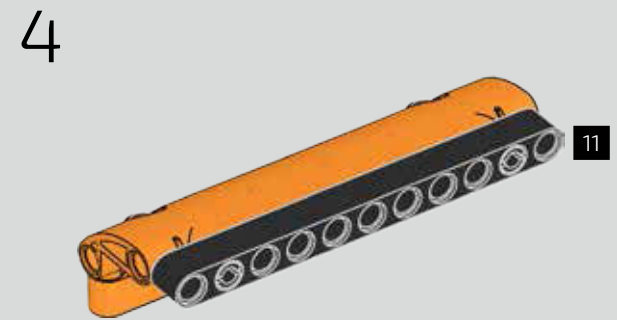
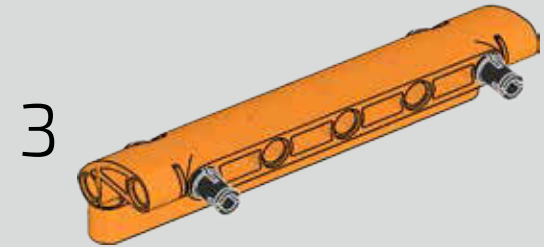
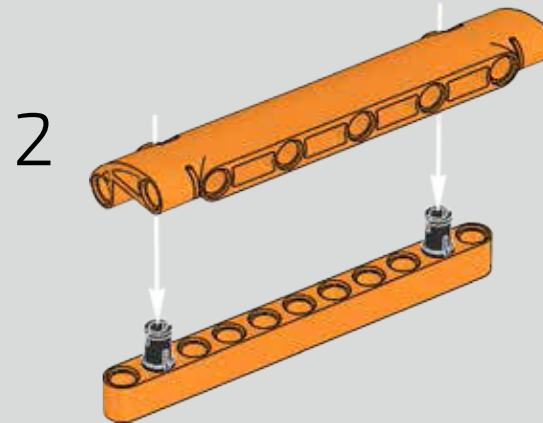
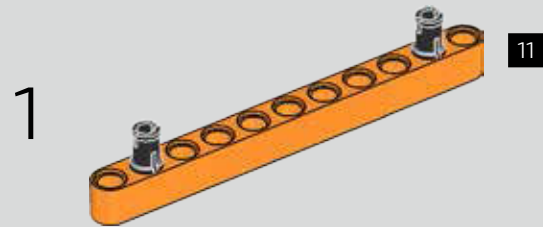
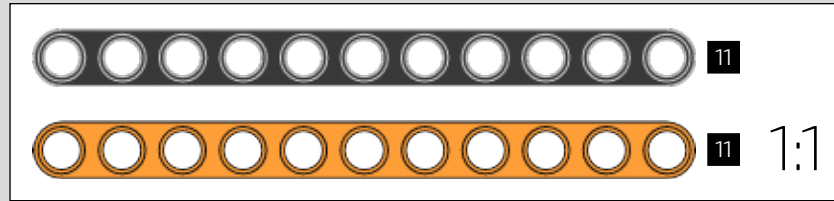

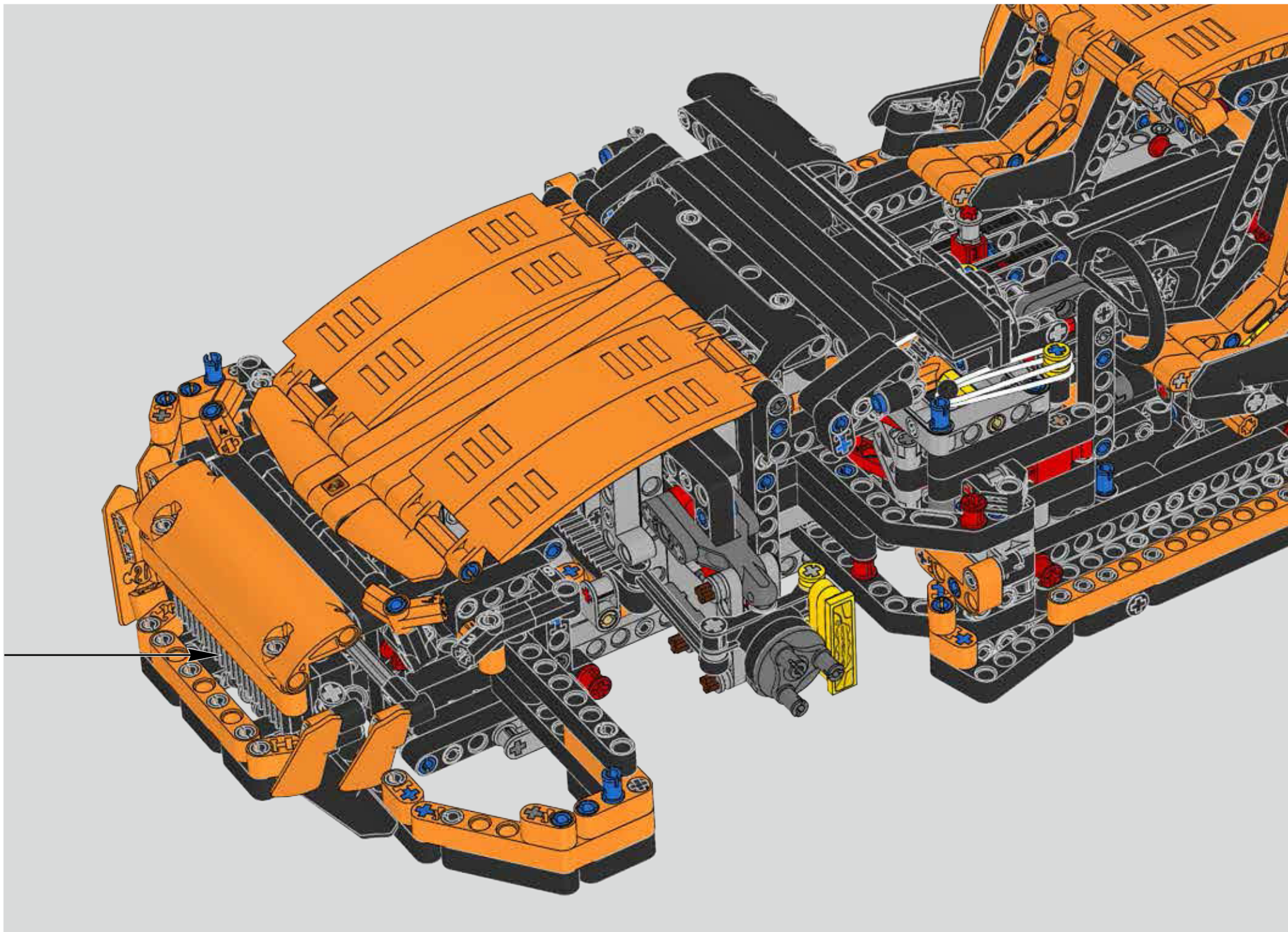

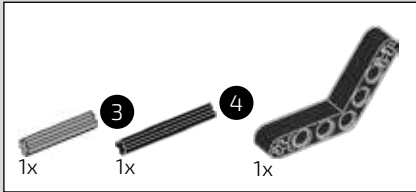

712

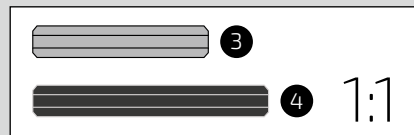
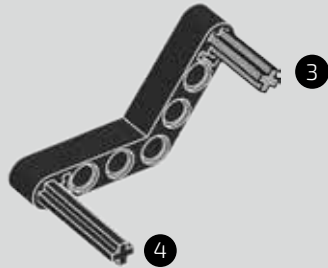

713



714



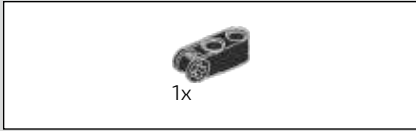

715



716

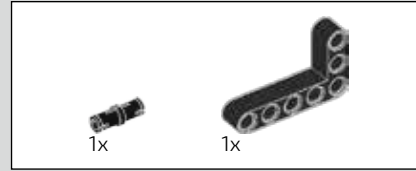
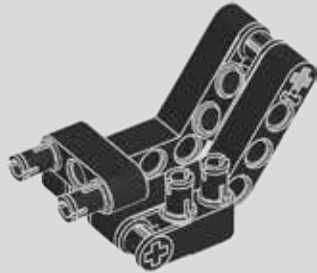

717

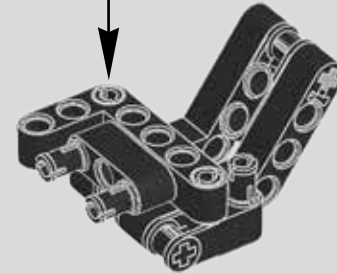

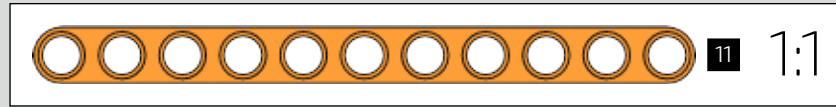
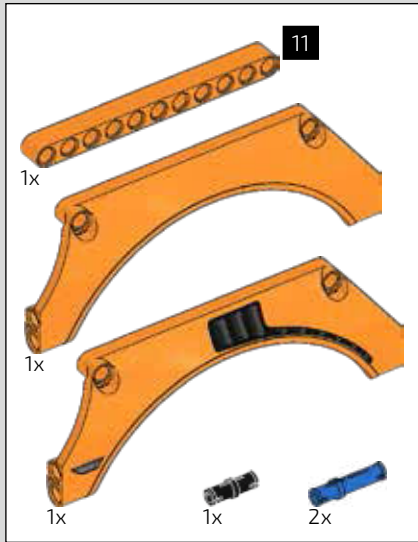

718

1

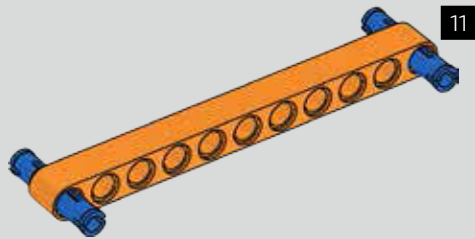

2

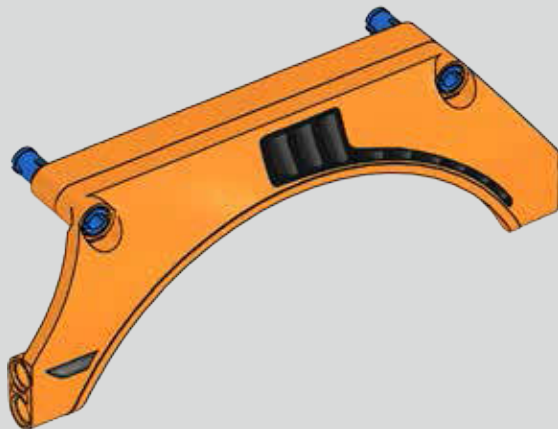

3

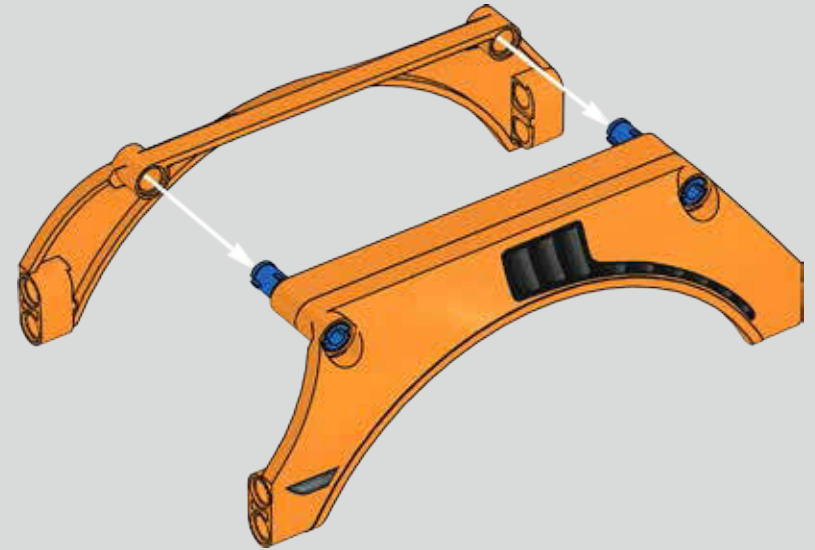

4

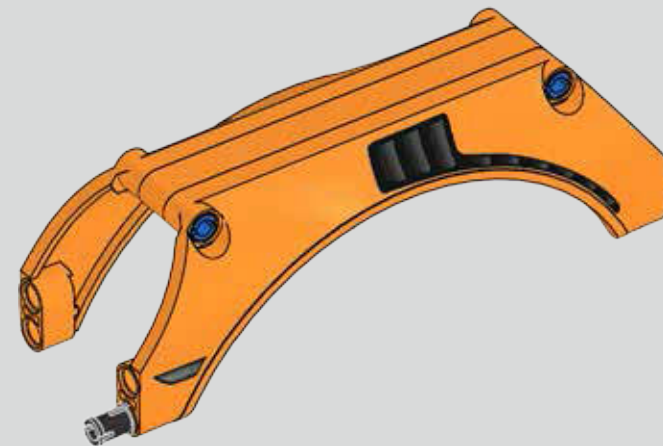

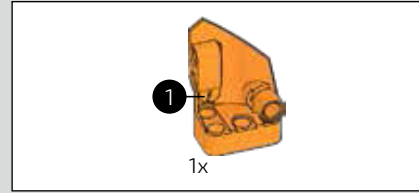
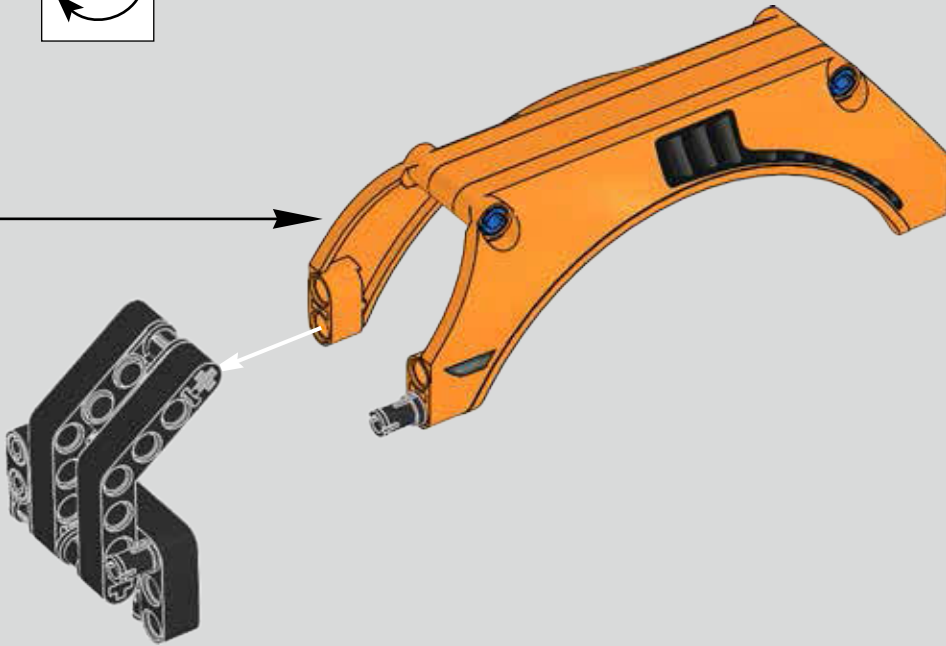
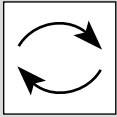

719

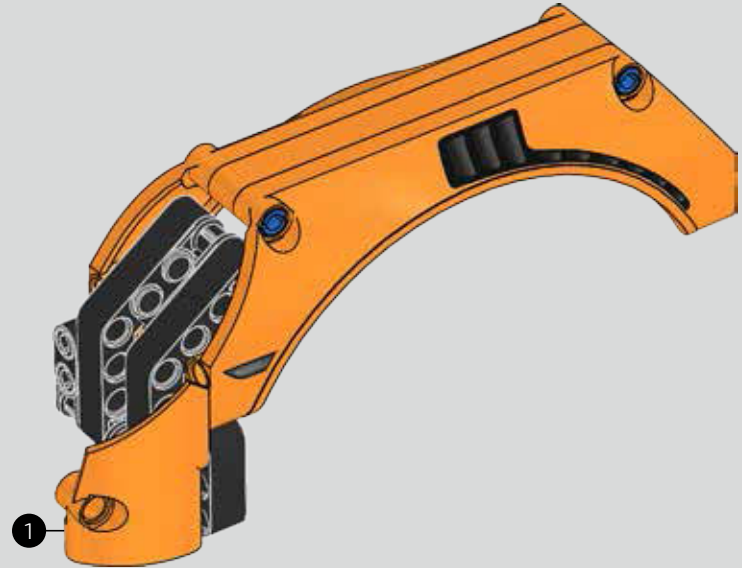

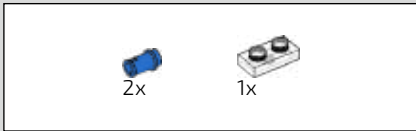

720

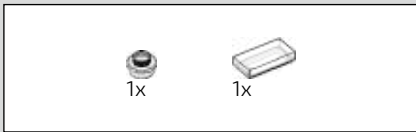
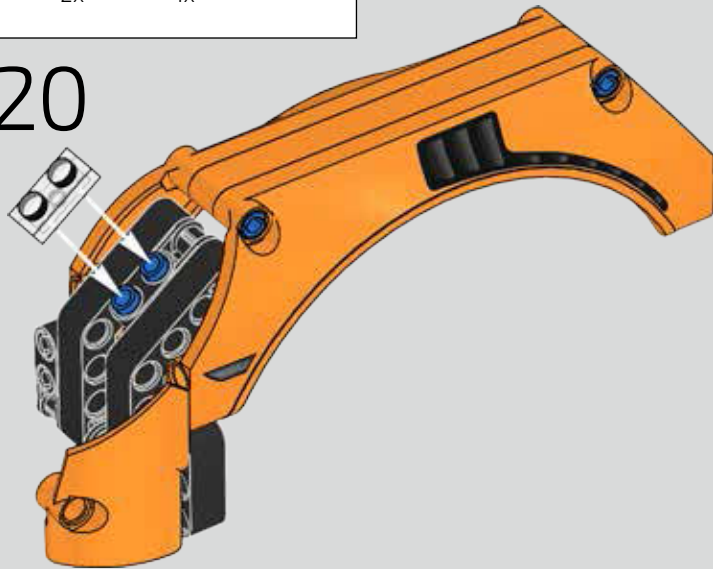

721

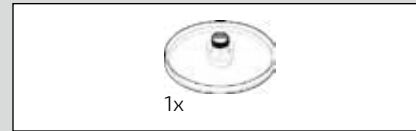
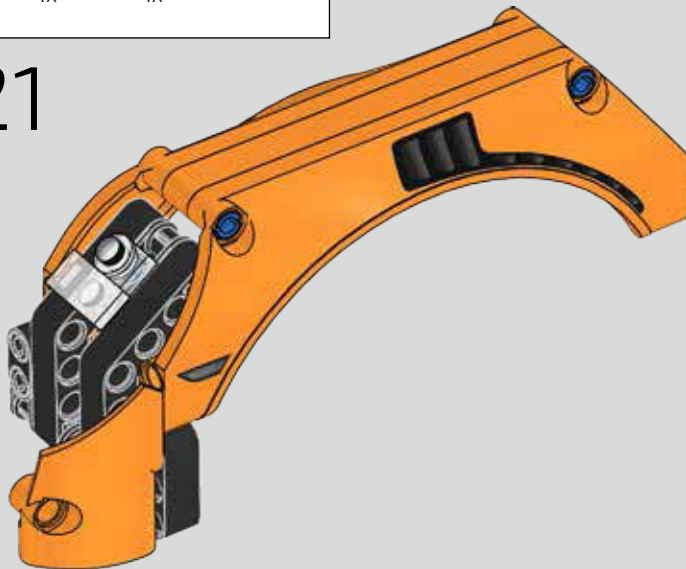

722

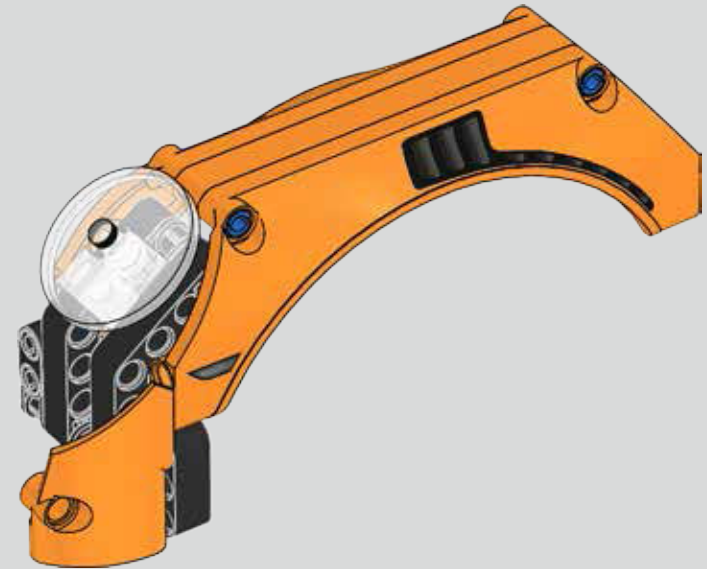

723

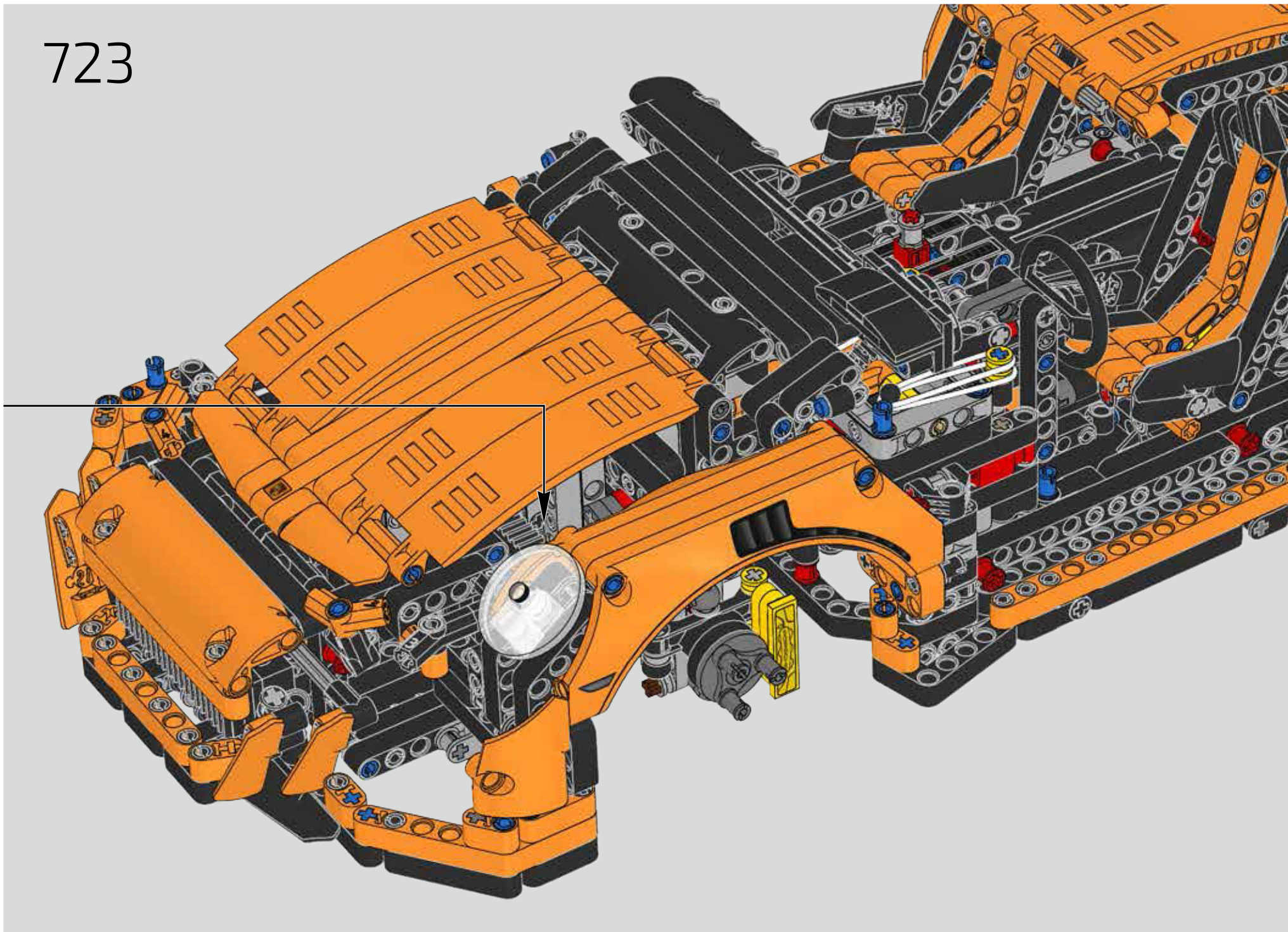

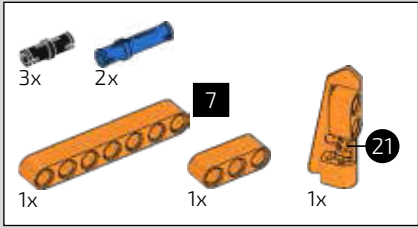

724

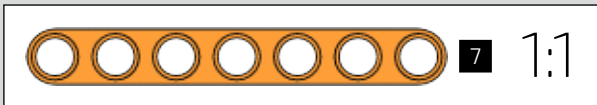
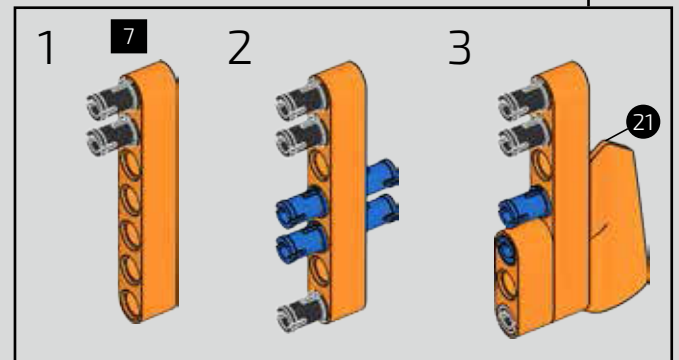
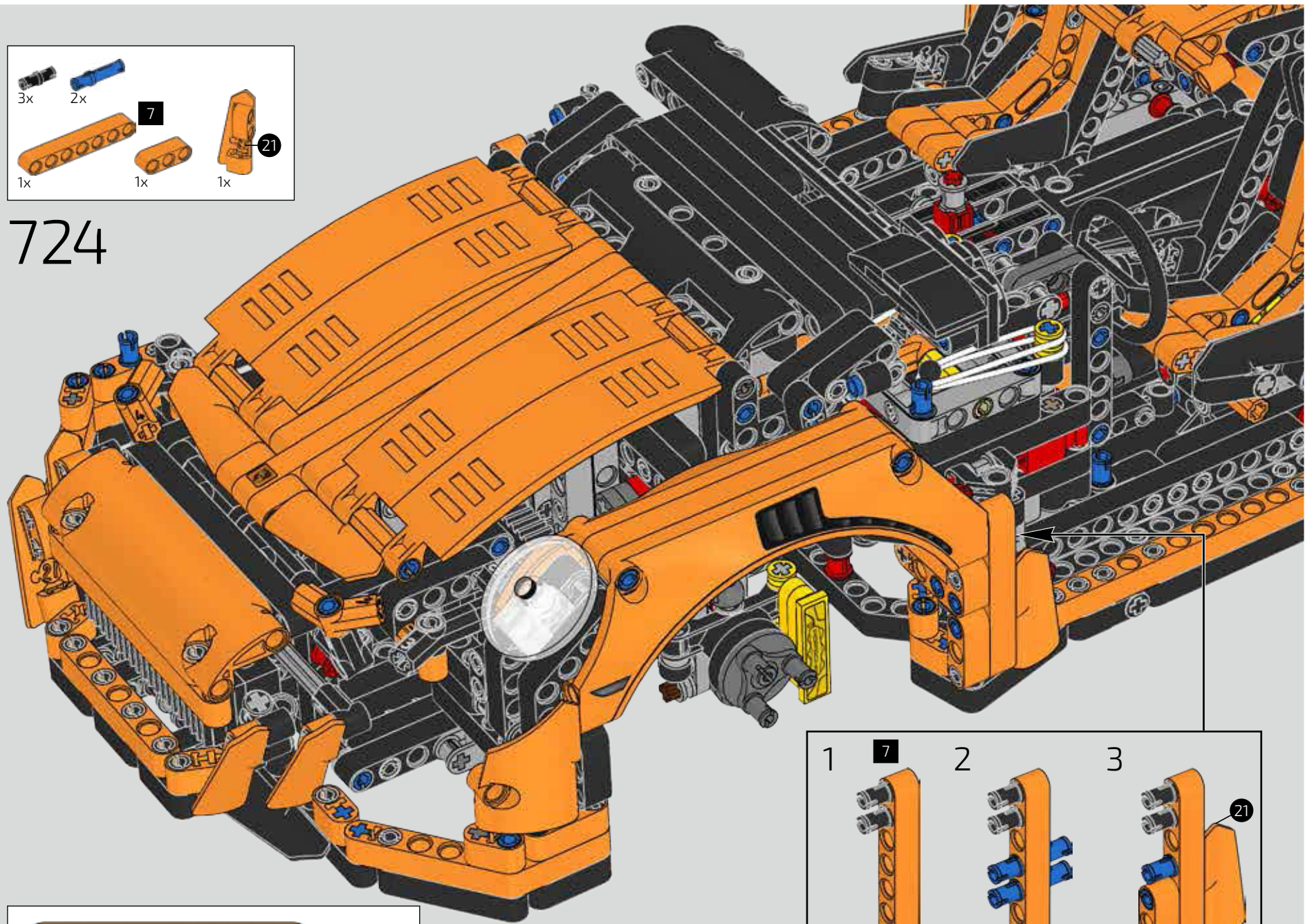

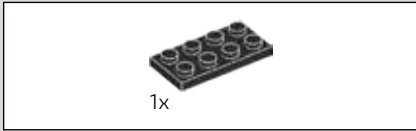
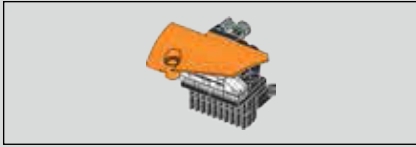

1x

725

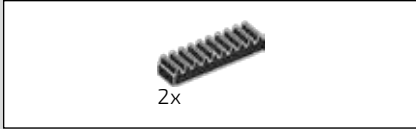
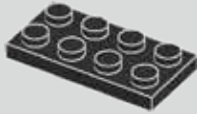

2x

726

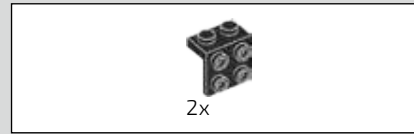
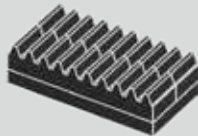

2x

727

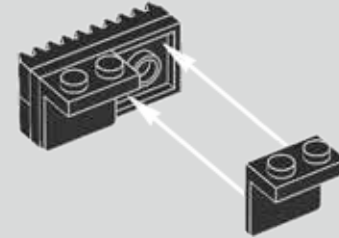

2x

728



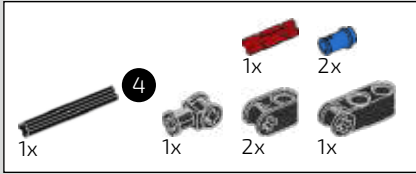

729

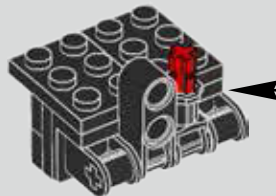
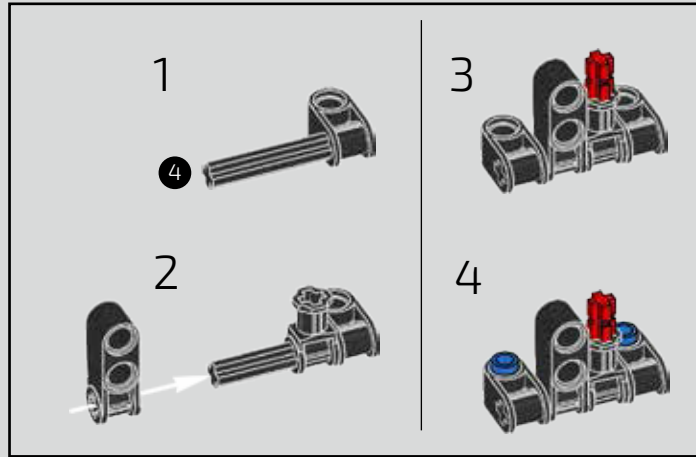

730

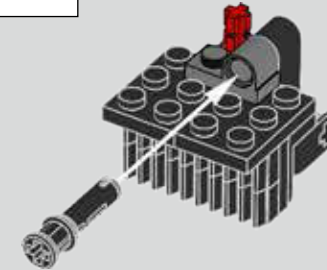
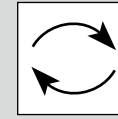

731

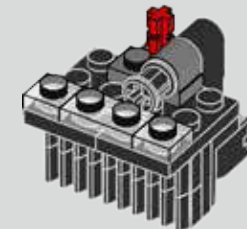

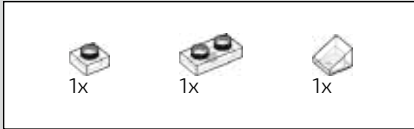

732

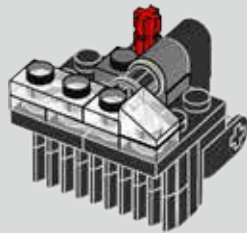

733

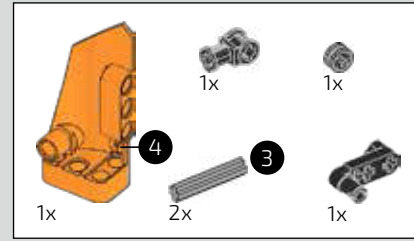
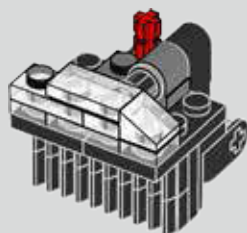

734

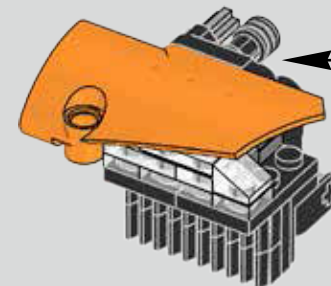
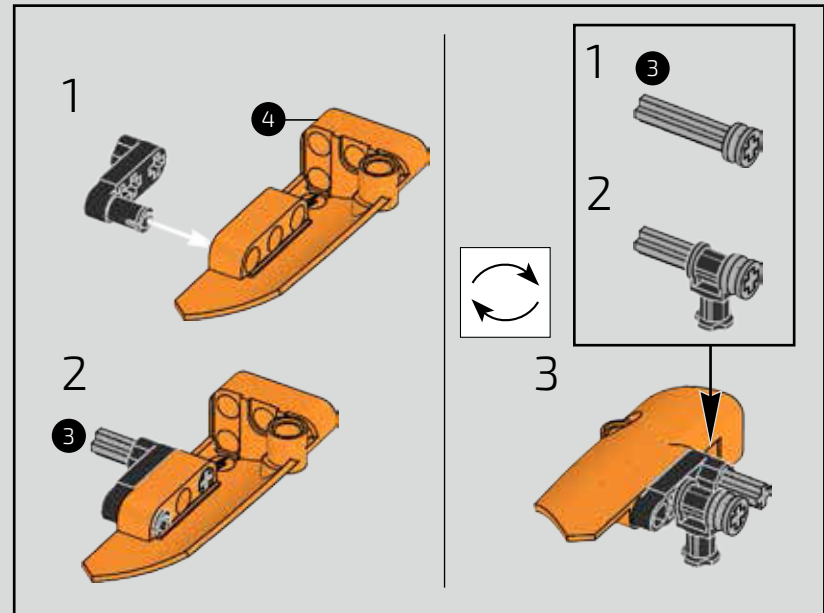
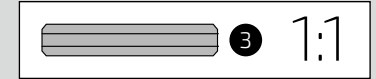

735

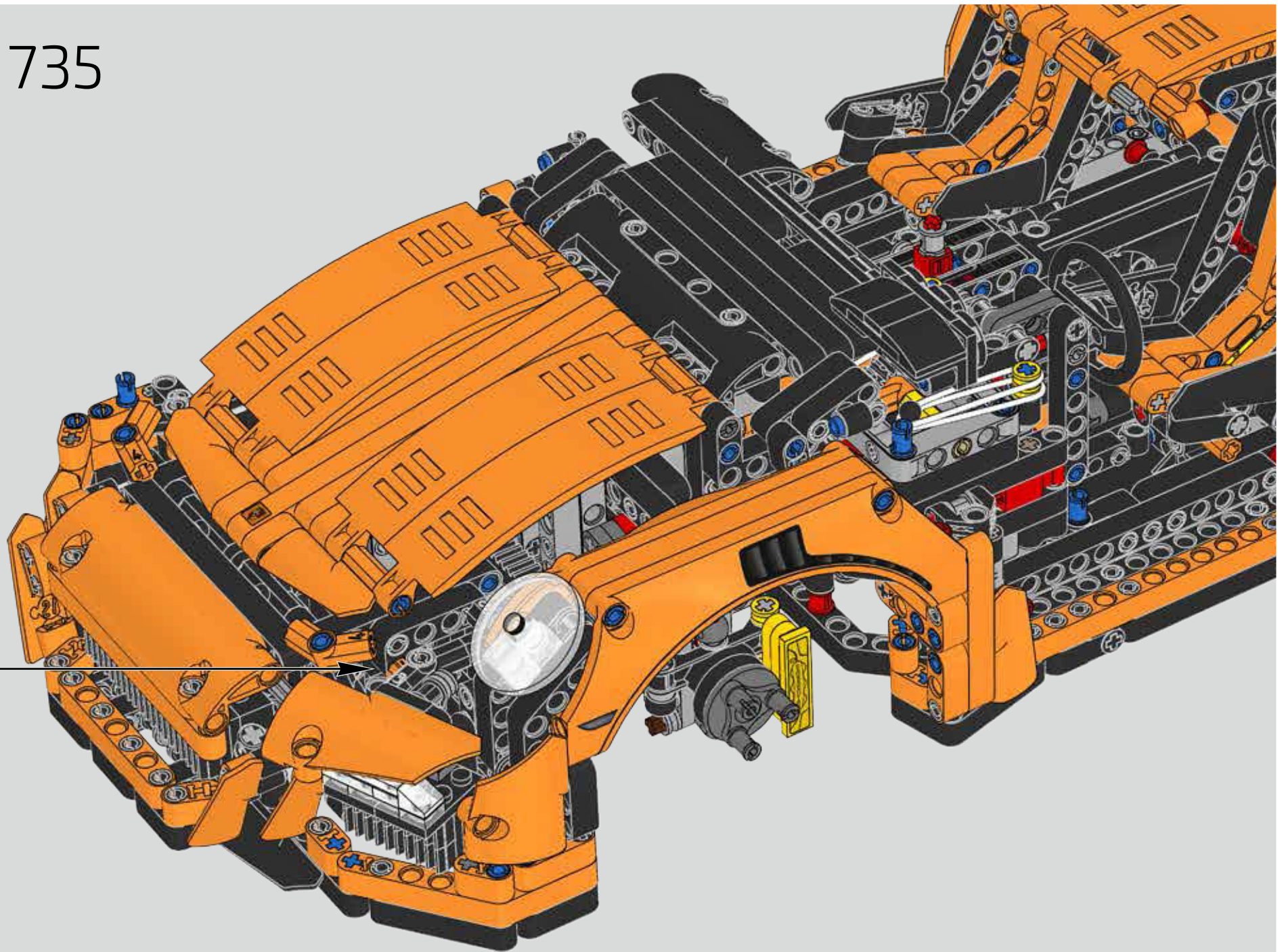

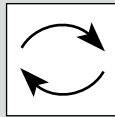
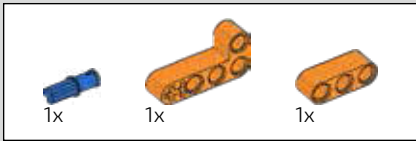

736

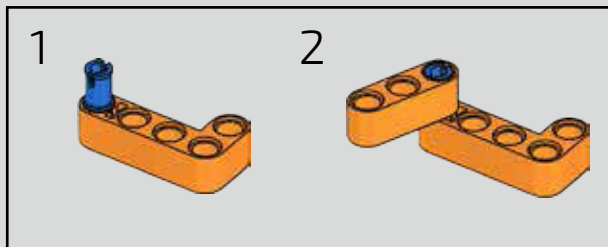
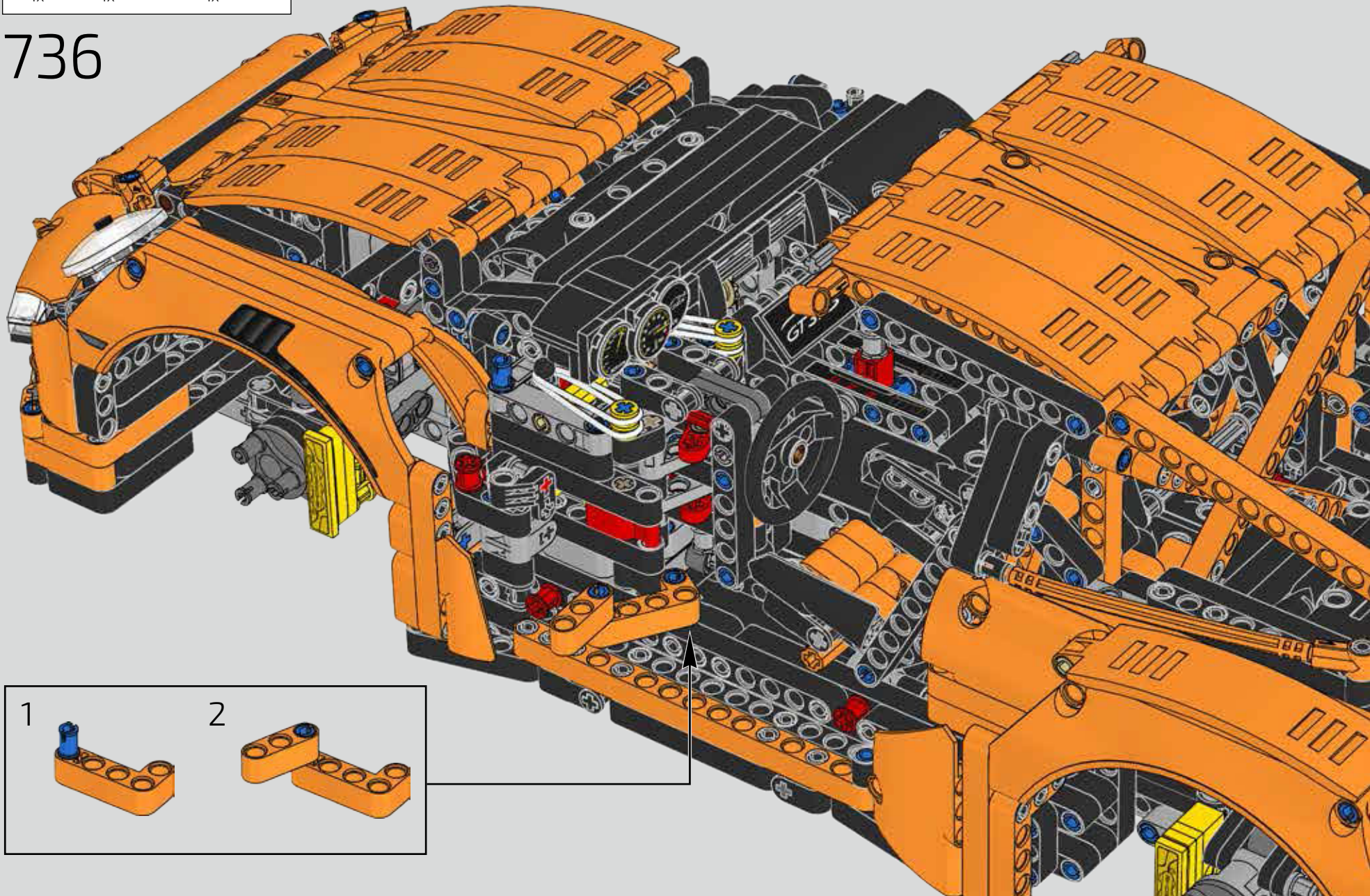

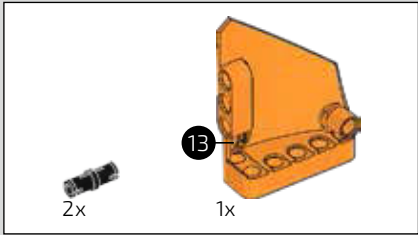
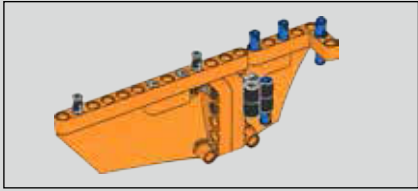

737

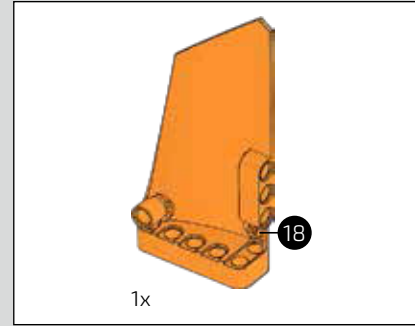
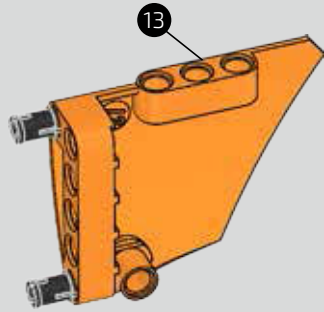

738

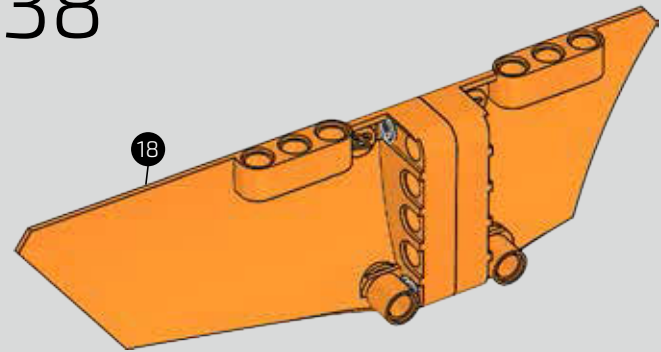

739

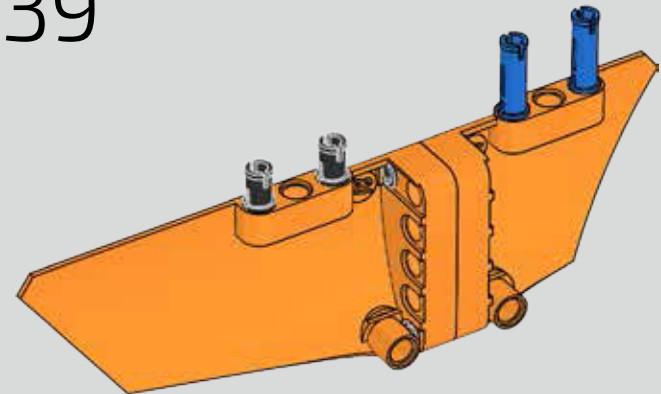

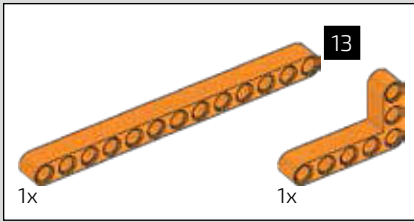

740

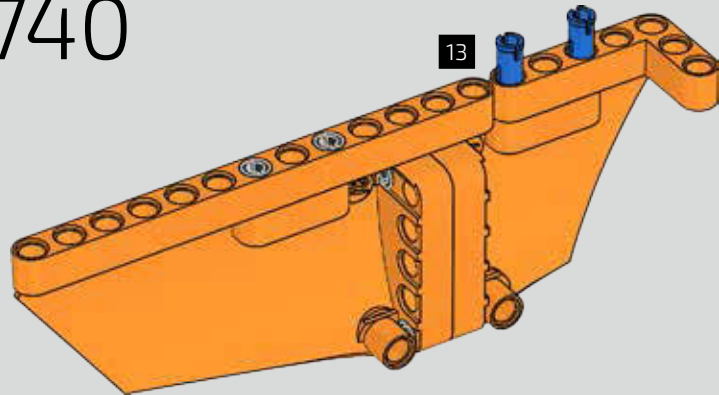

741

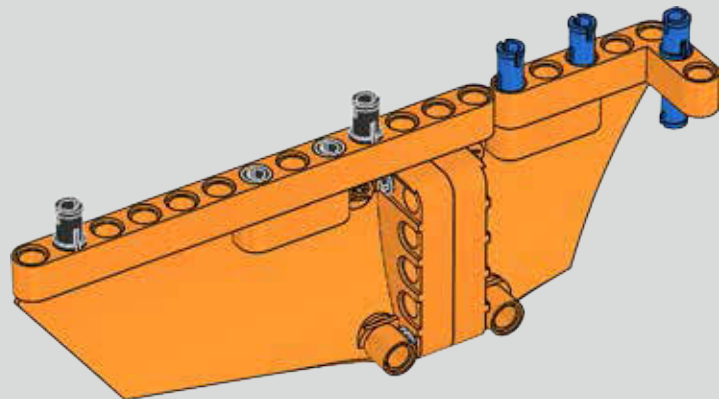

742

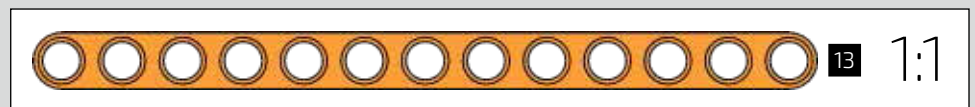
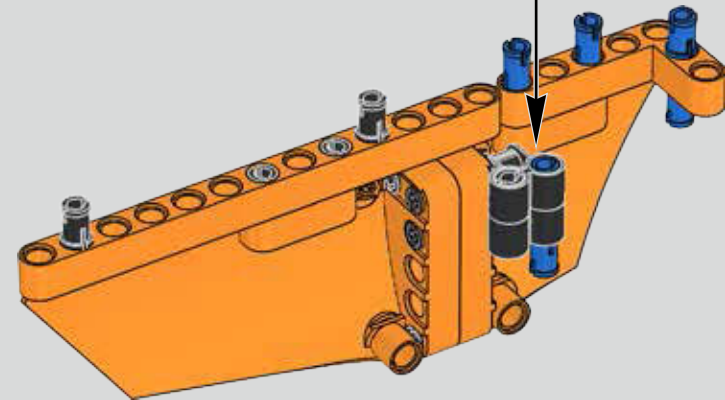
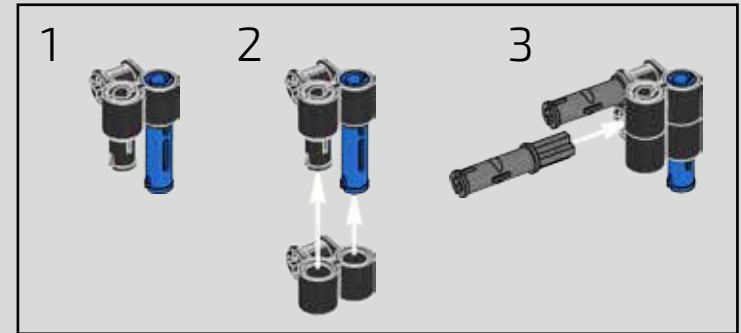

743

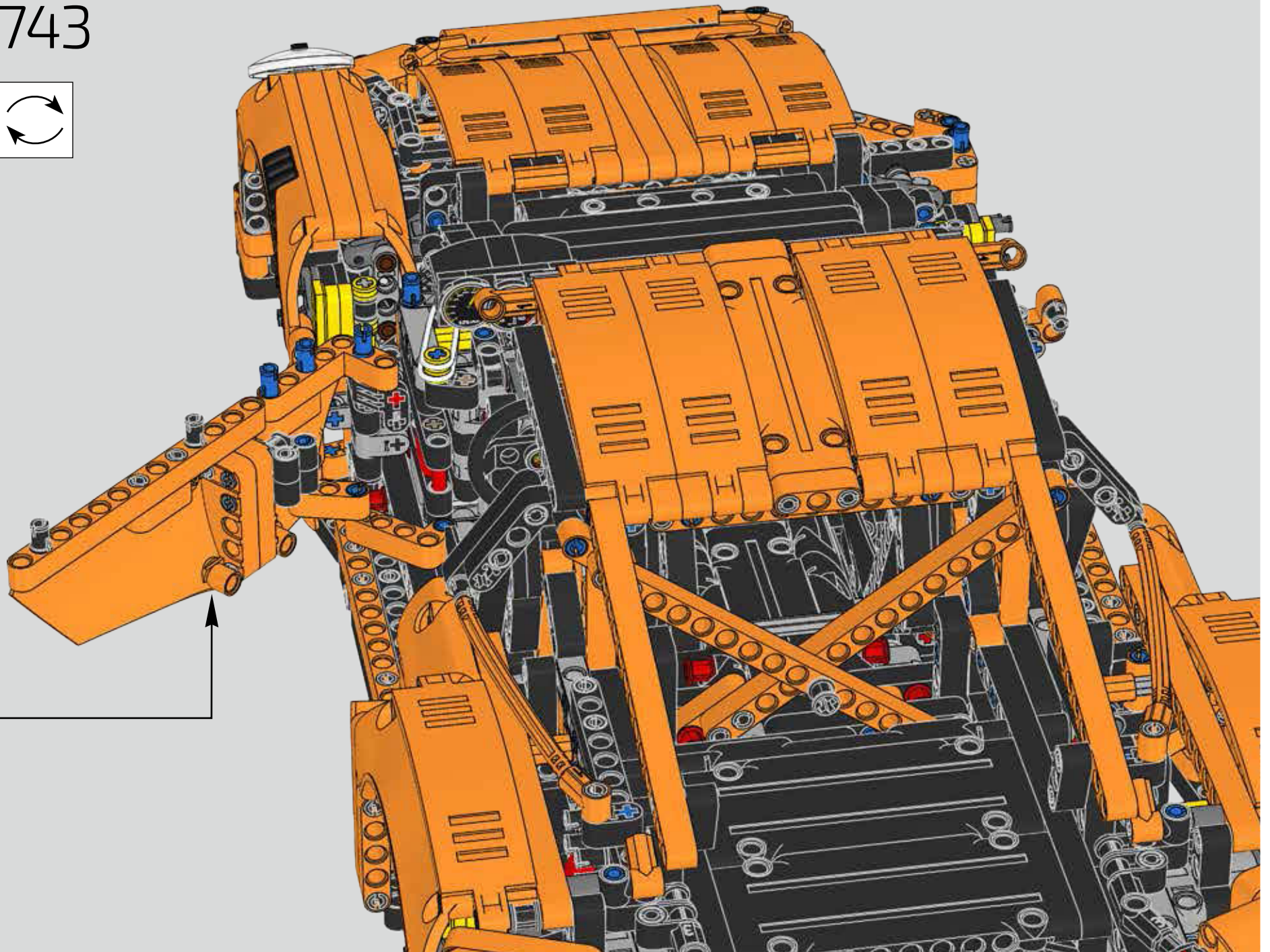
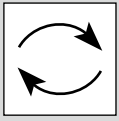

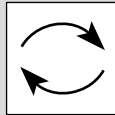
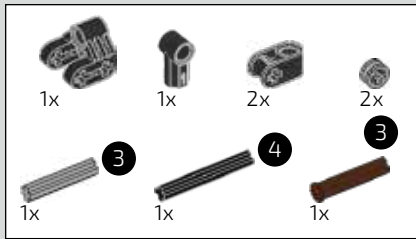

744

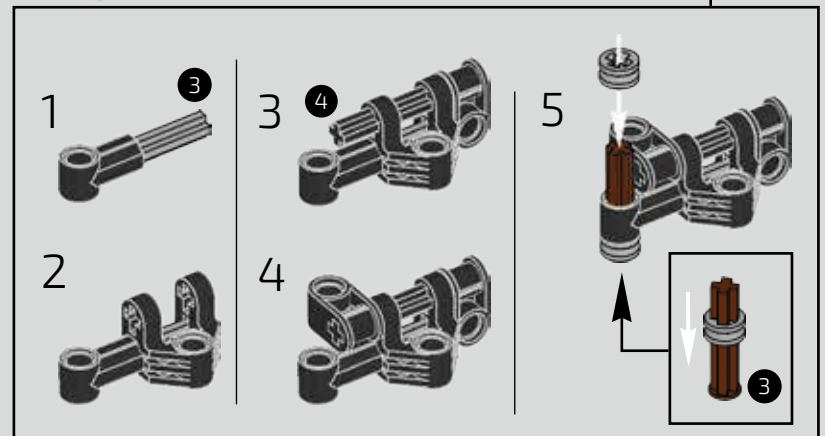
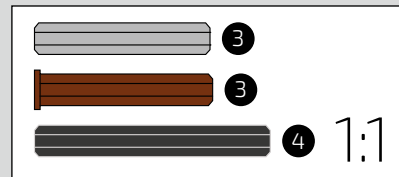
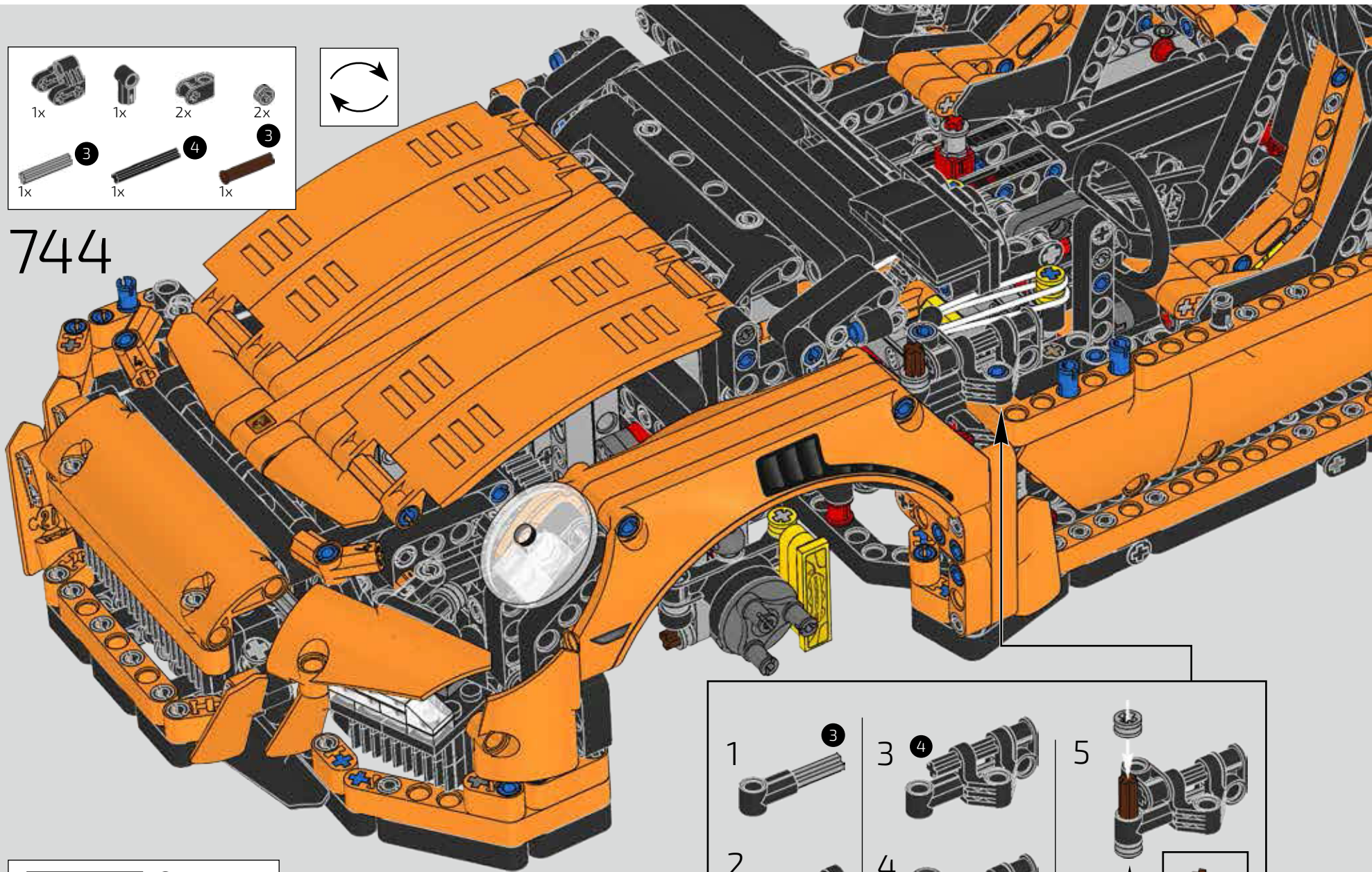

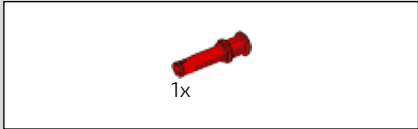

745

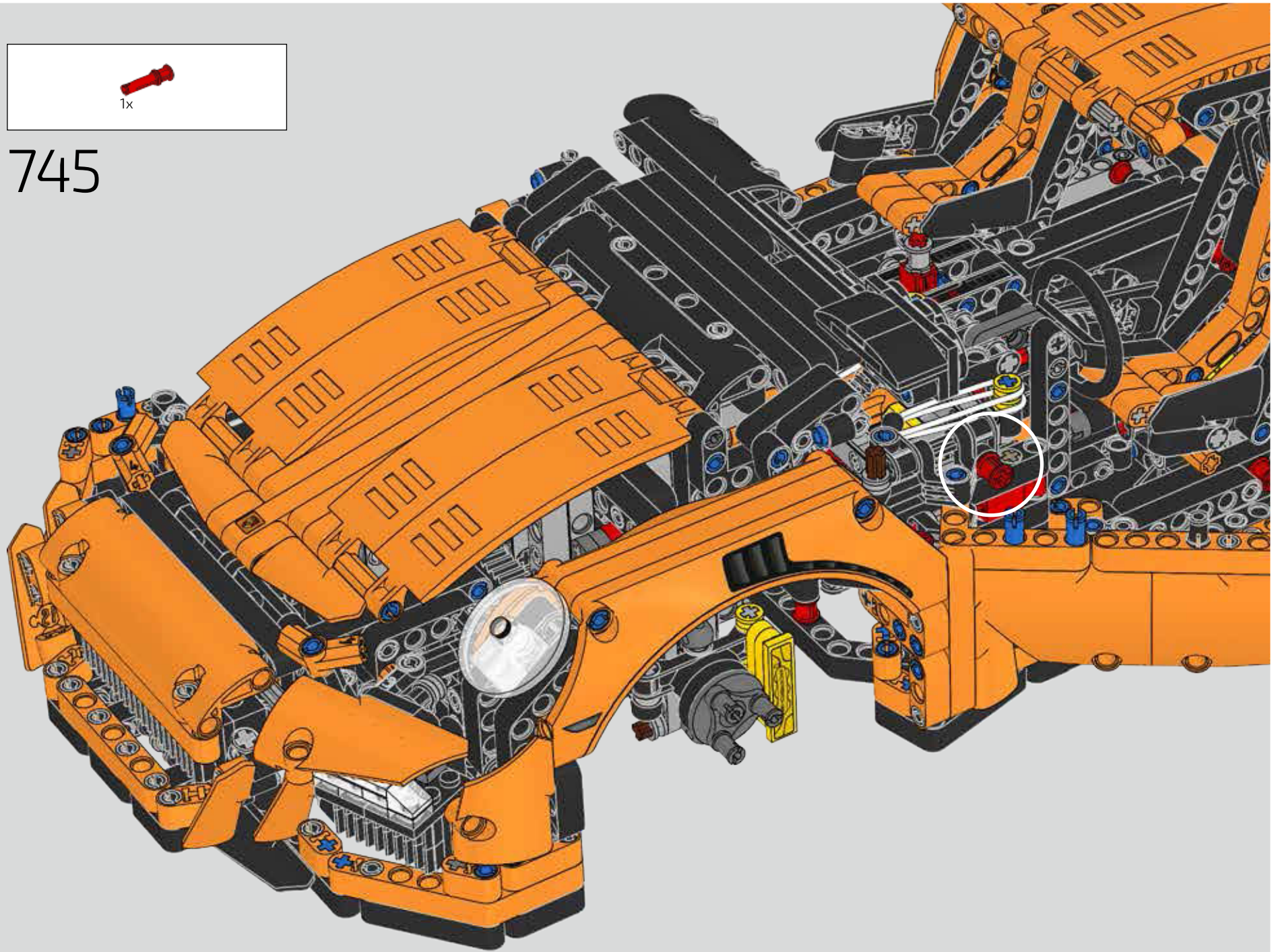

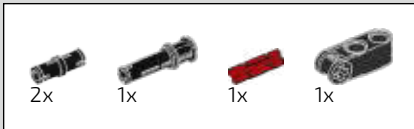

746

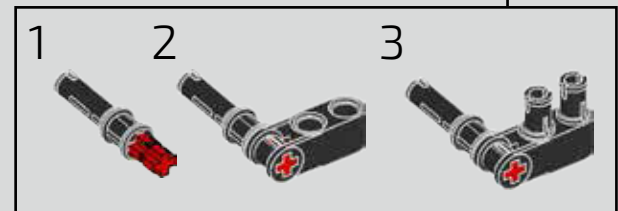
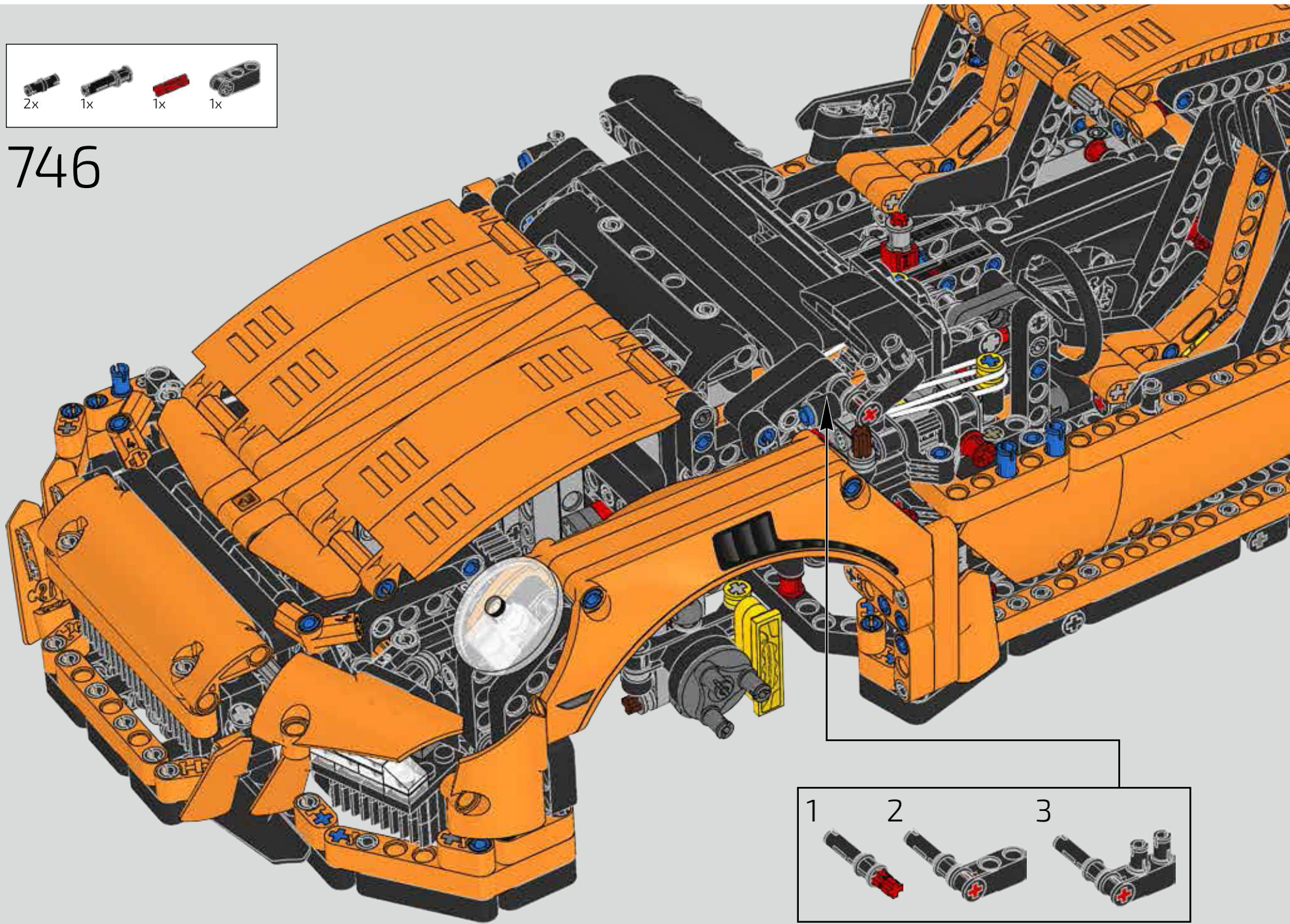



747

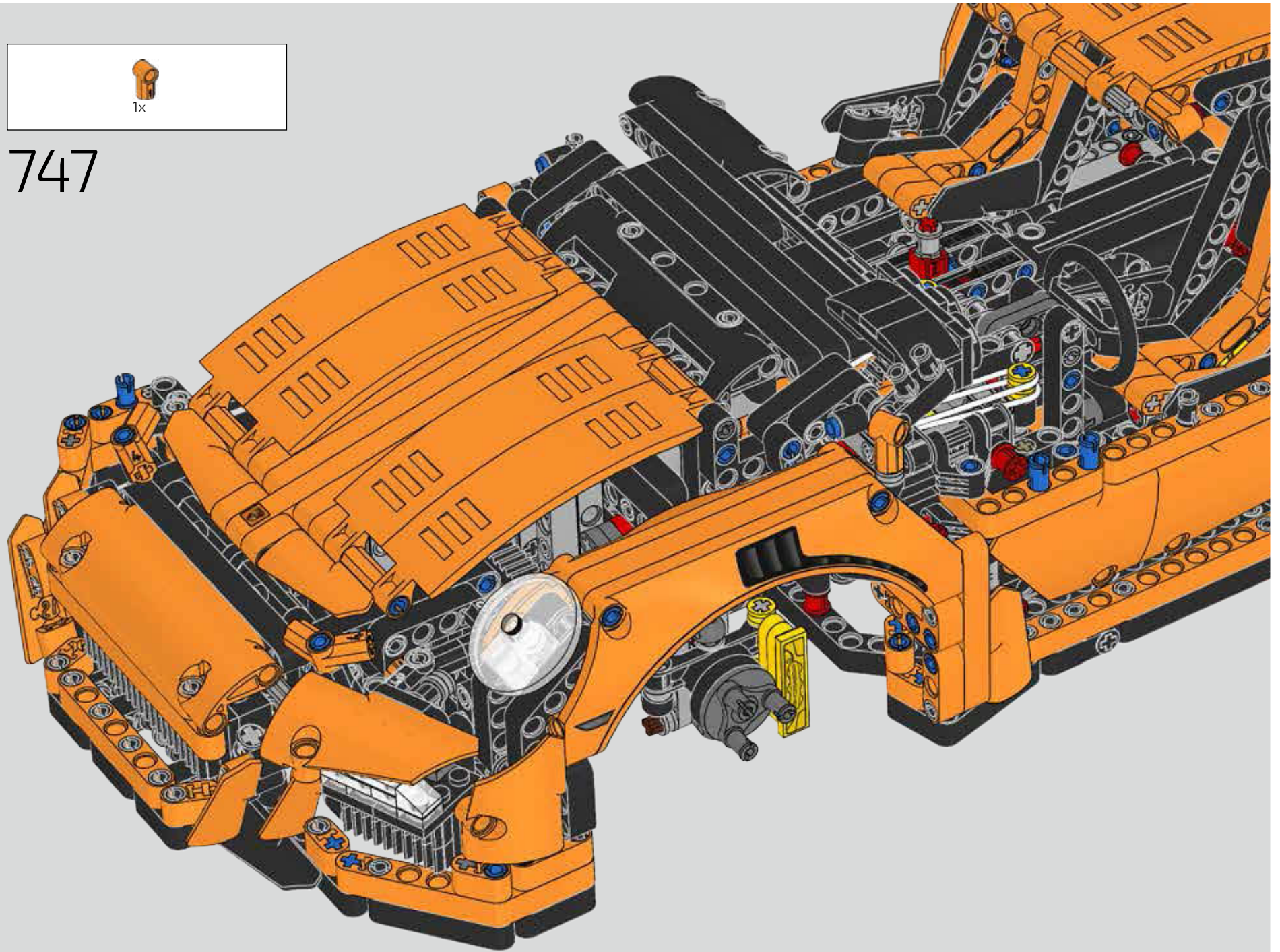

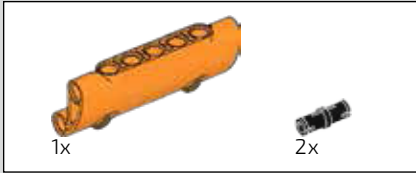
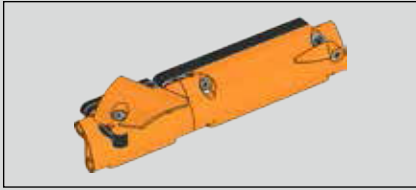

748

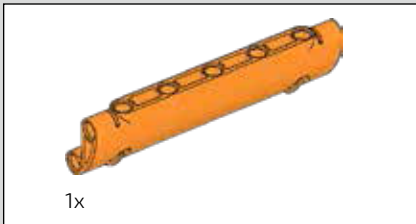
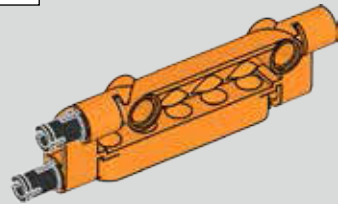

749

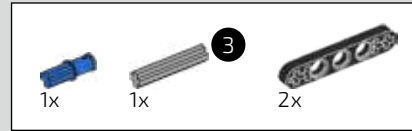
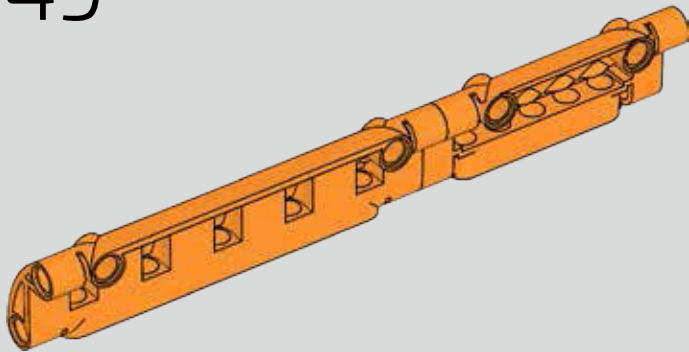

750

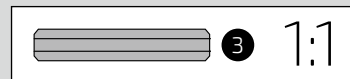
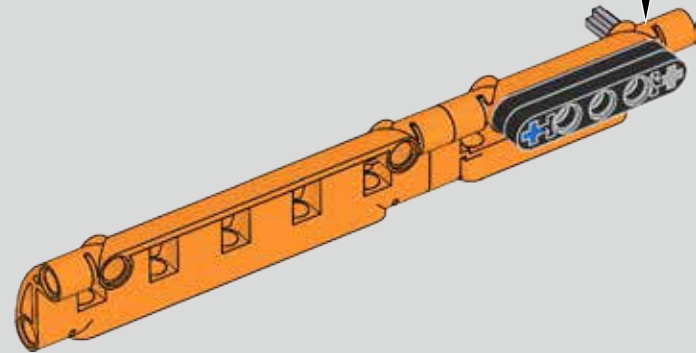
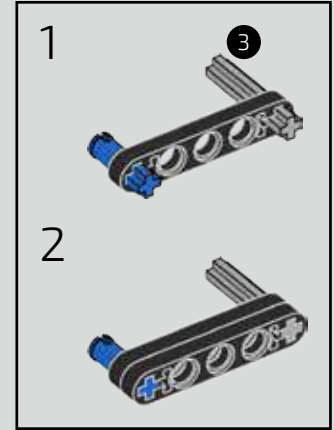

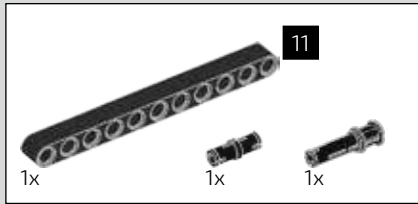

751

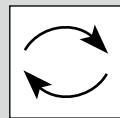
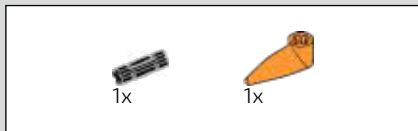
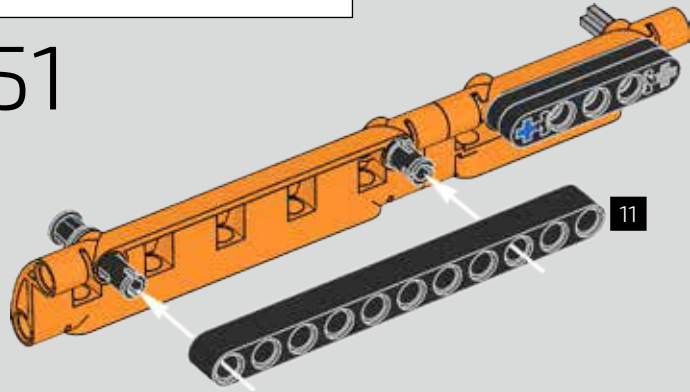

752

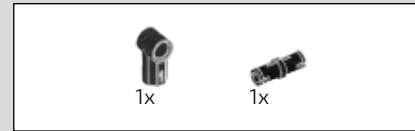
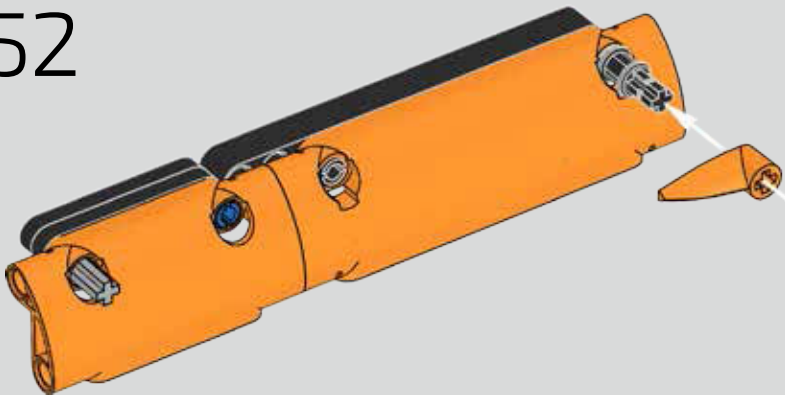

753

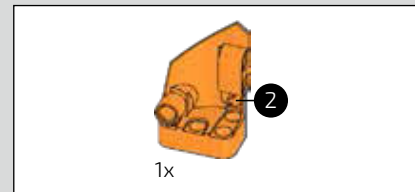
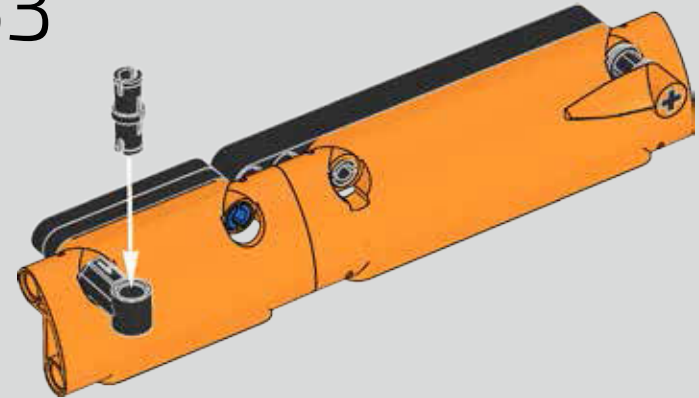

754

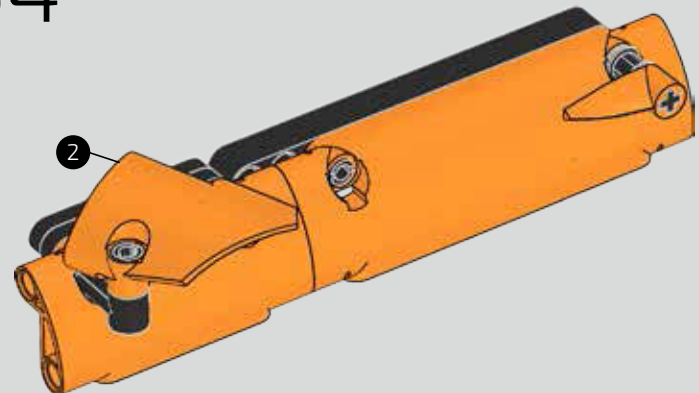

755

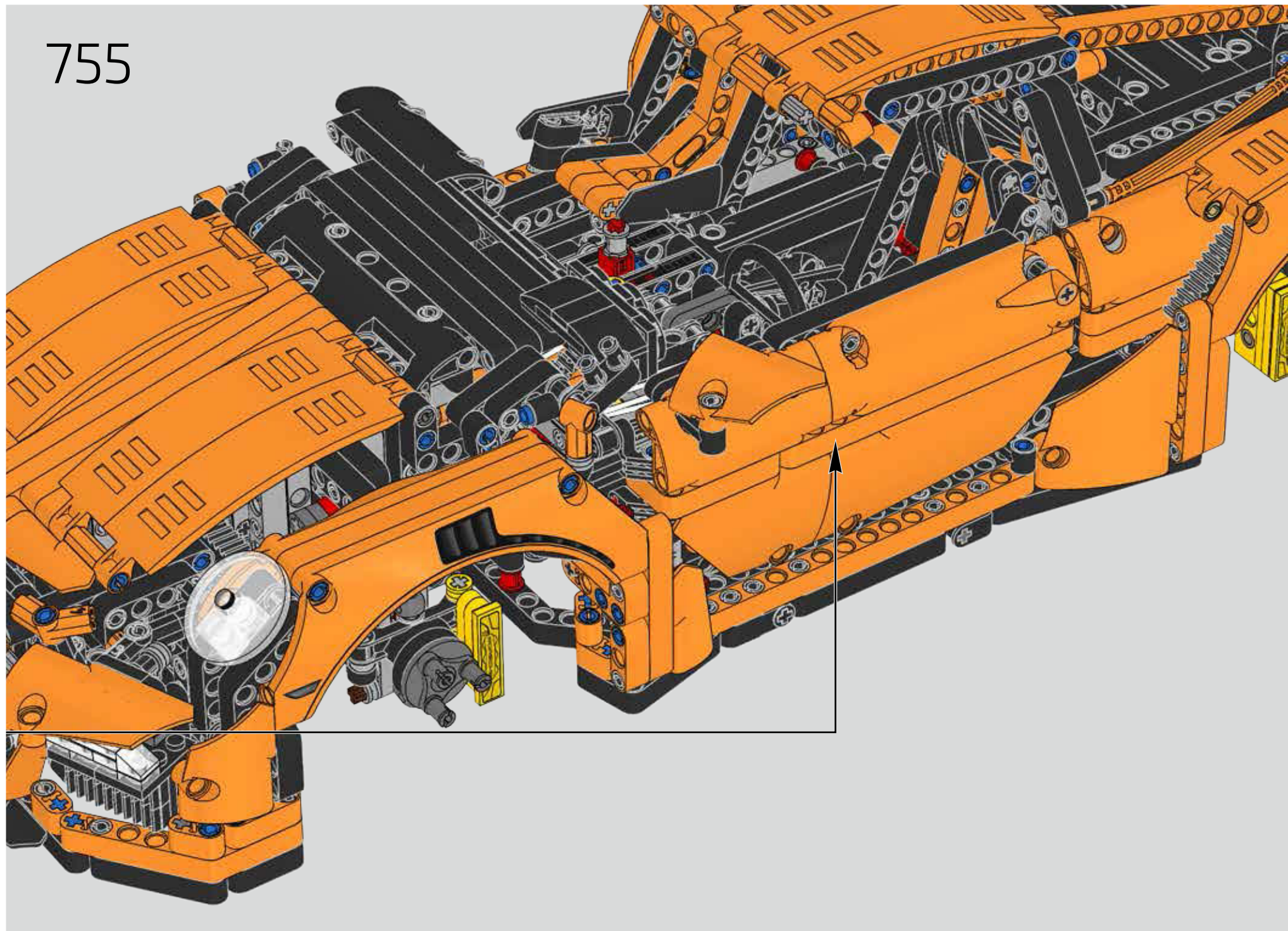

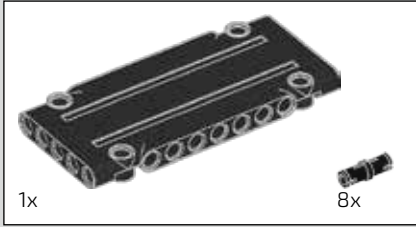
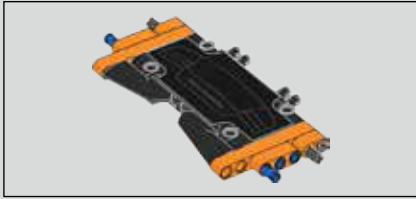

756

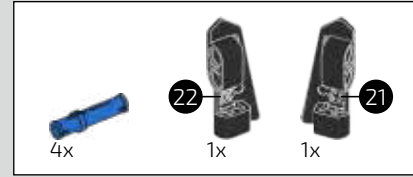
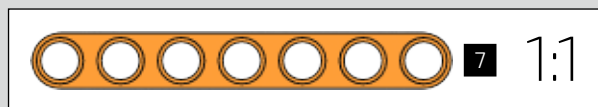
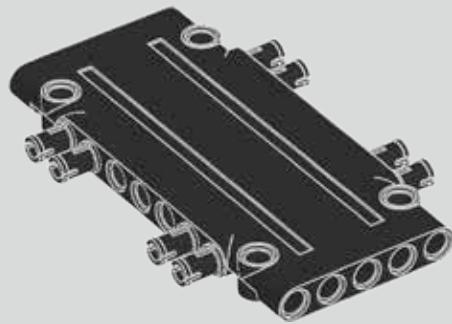

757

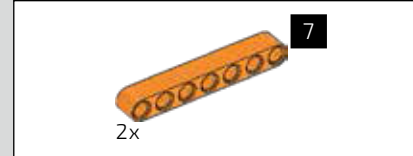
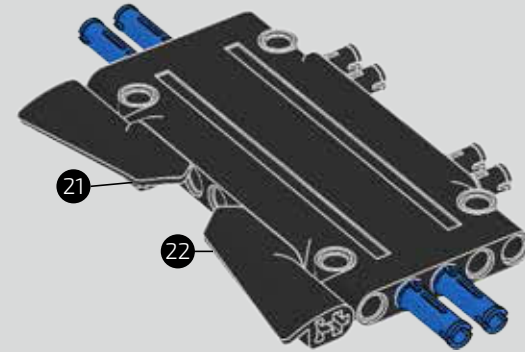

758

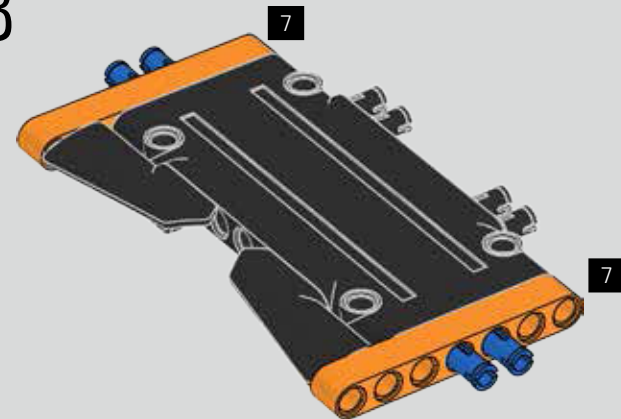

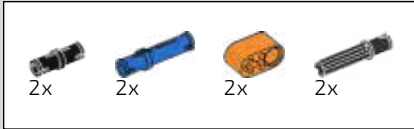

759

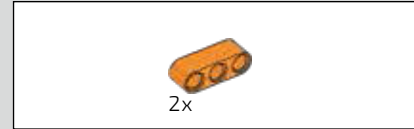
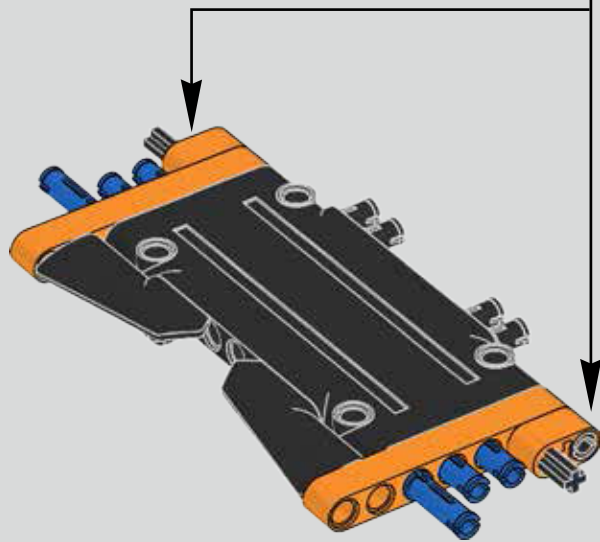

760

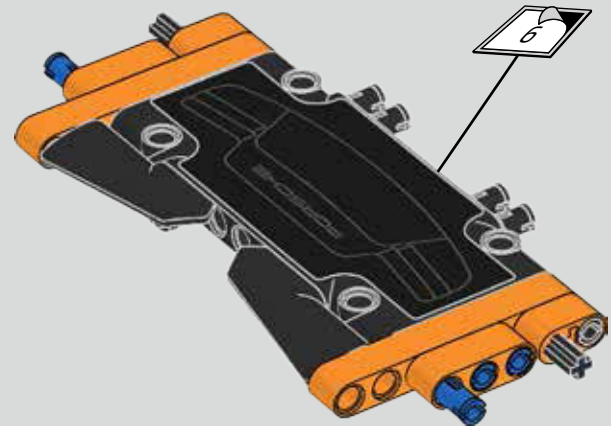

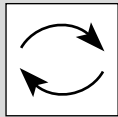

761

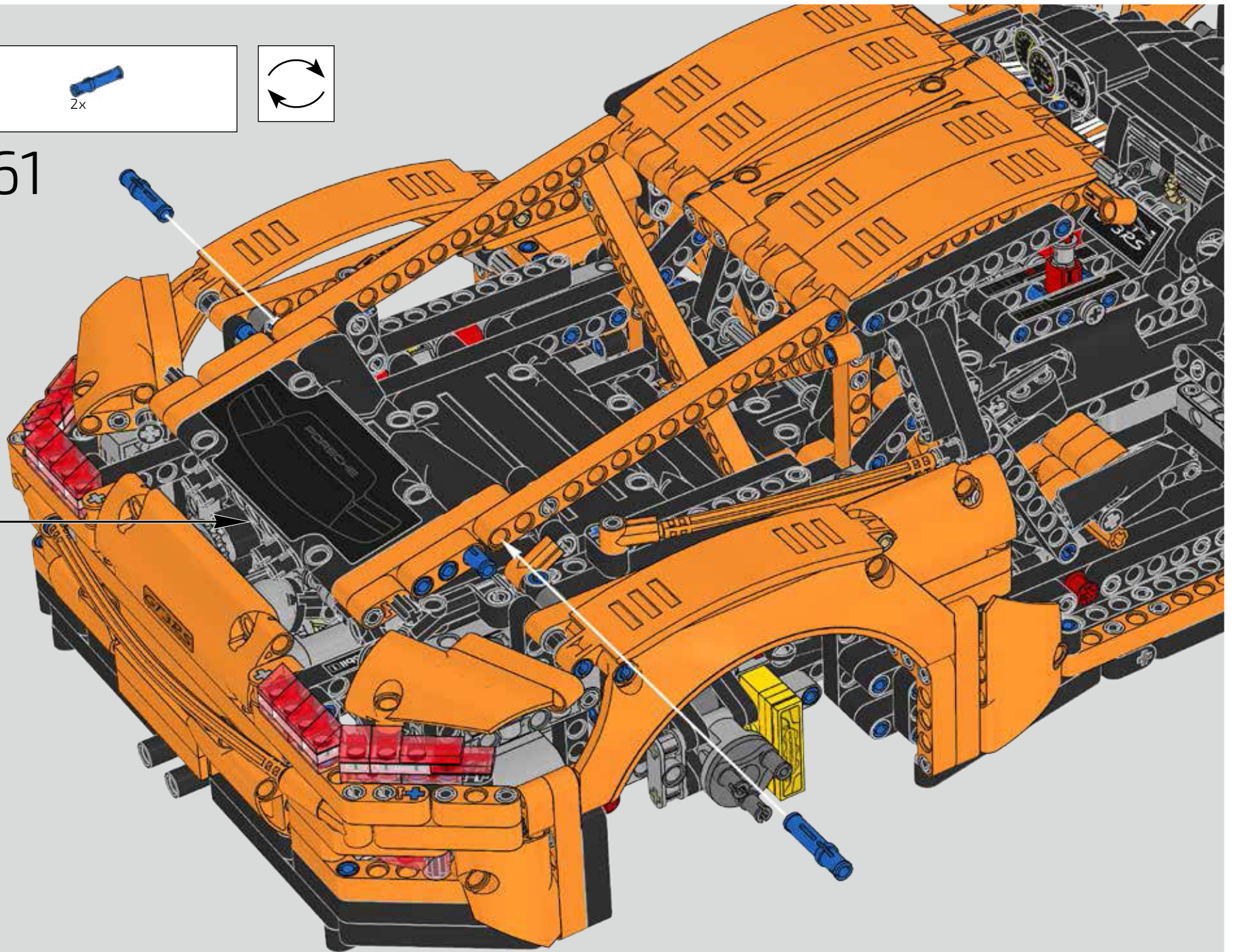

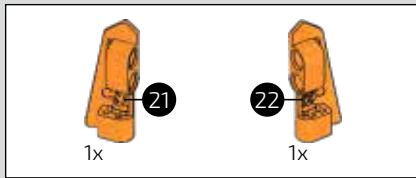

762

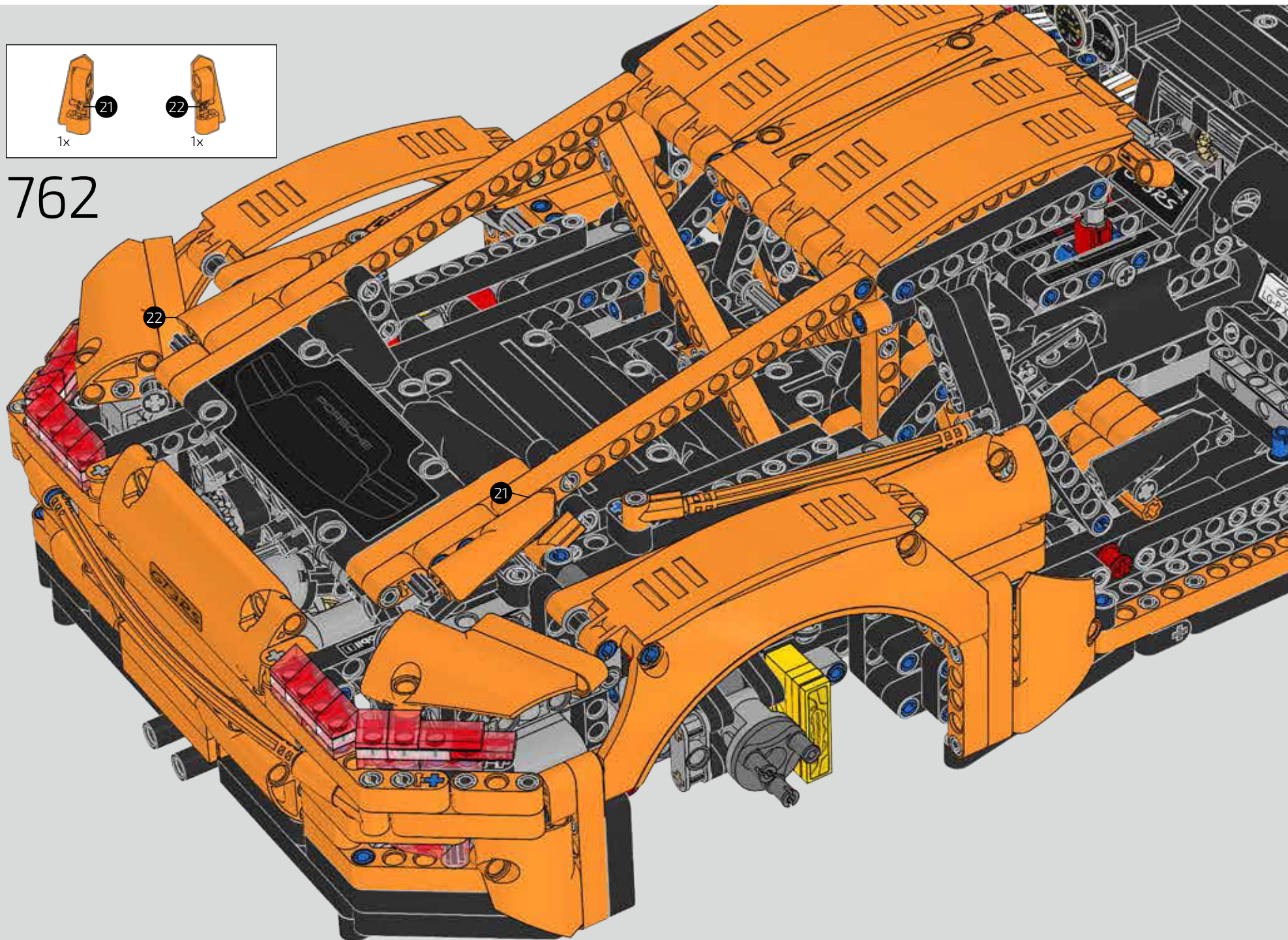

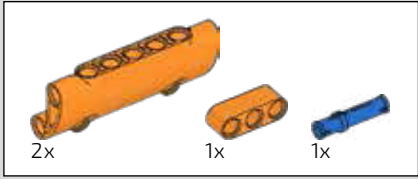

763

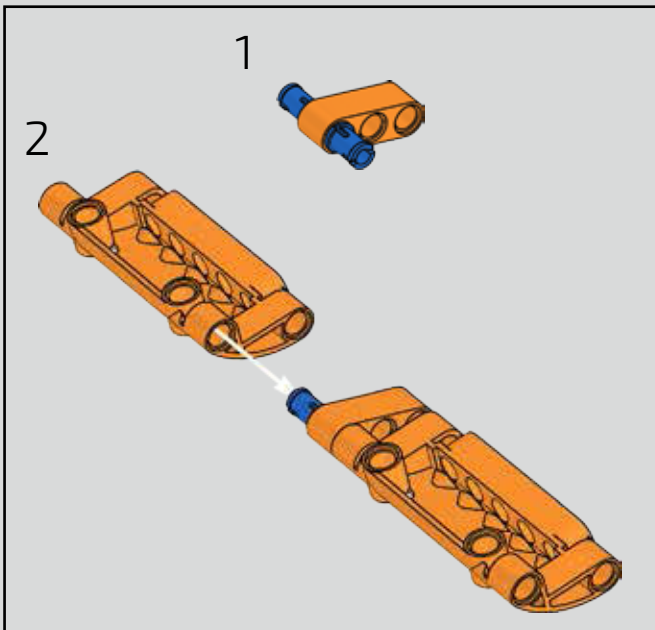
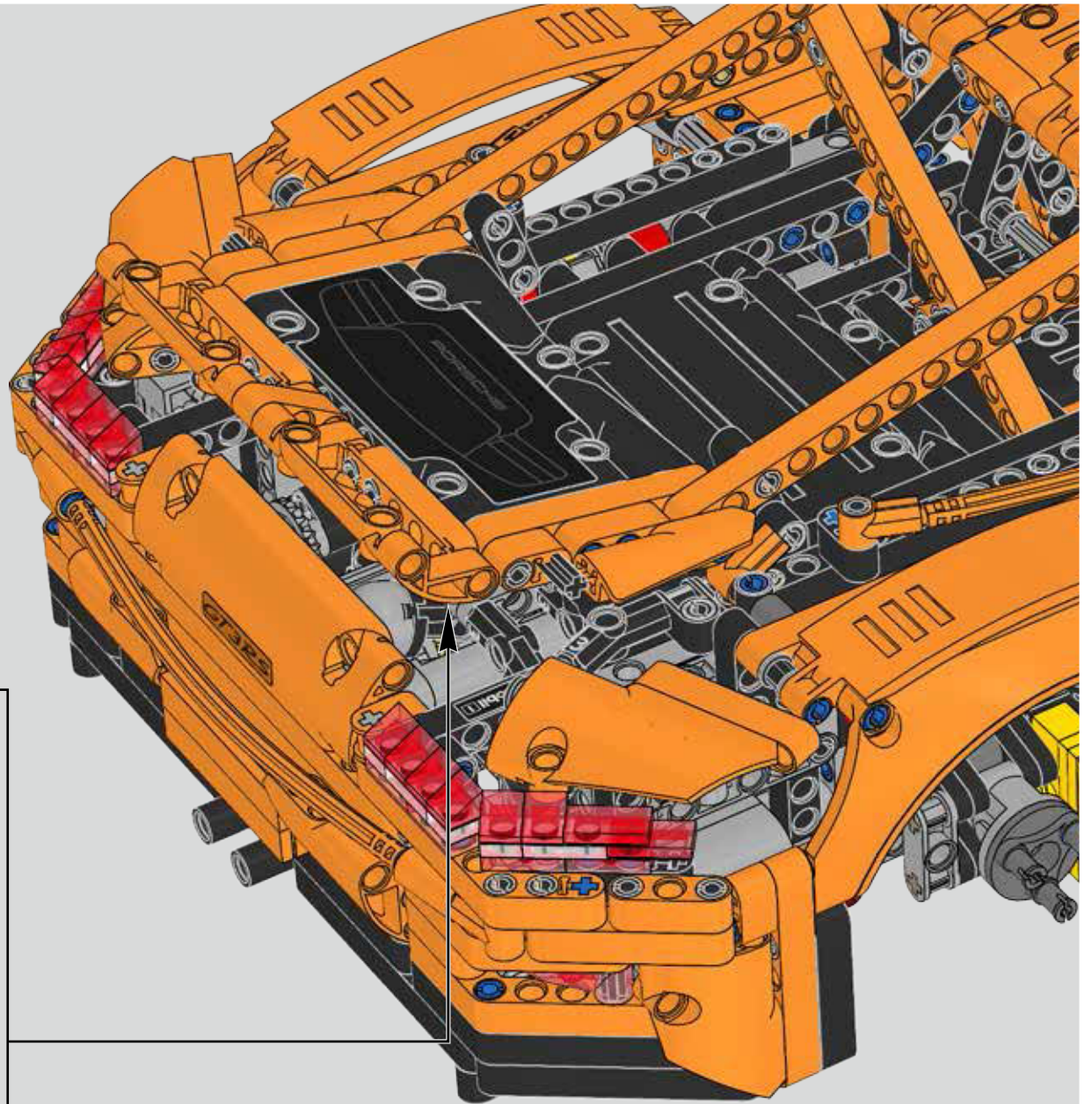

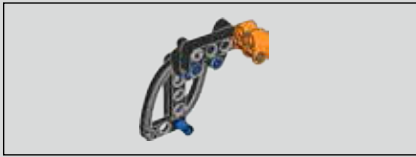

764

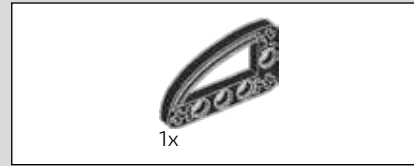
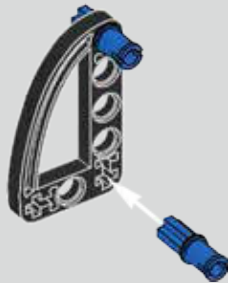

765



766

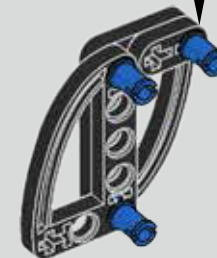

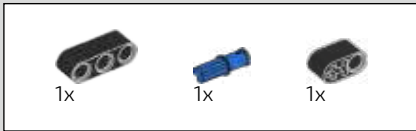

767

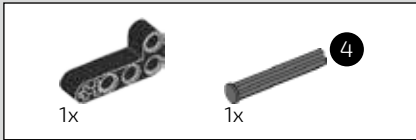
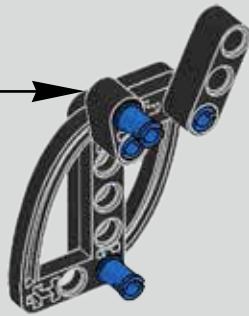
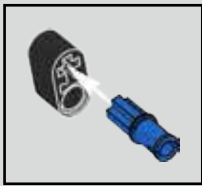

768

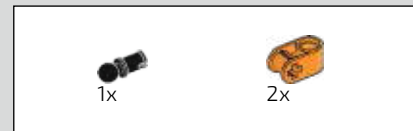
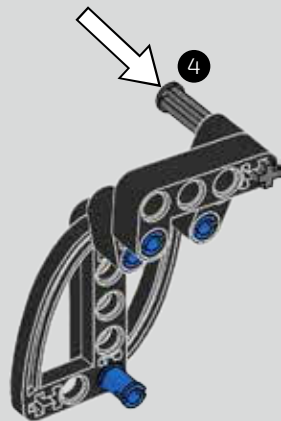

769

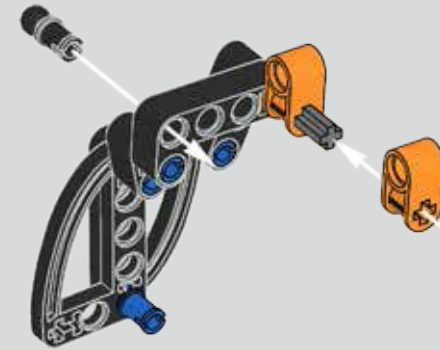

770

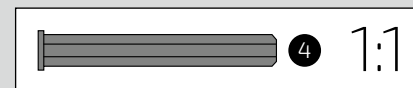
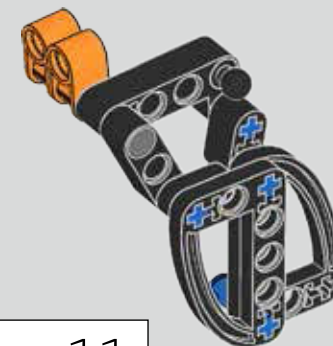
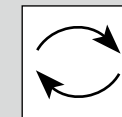

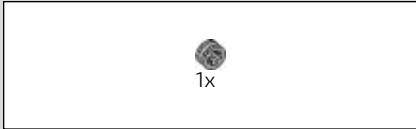

771

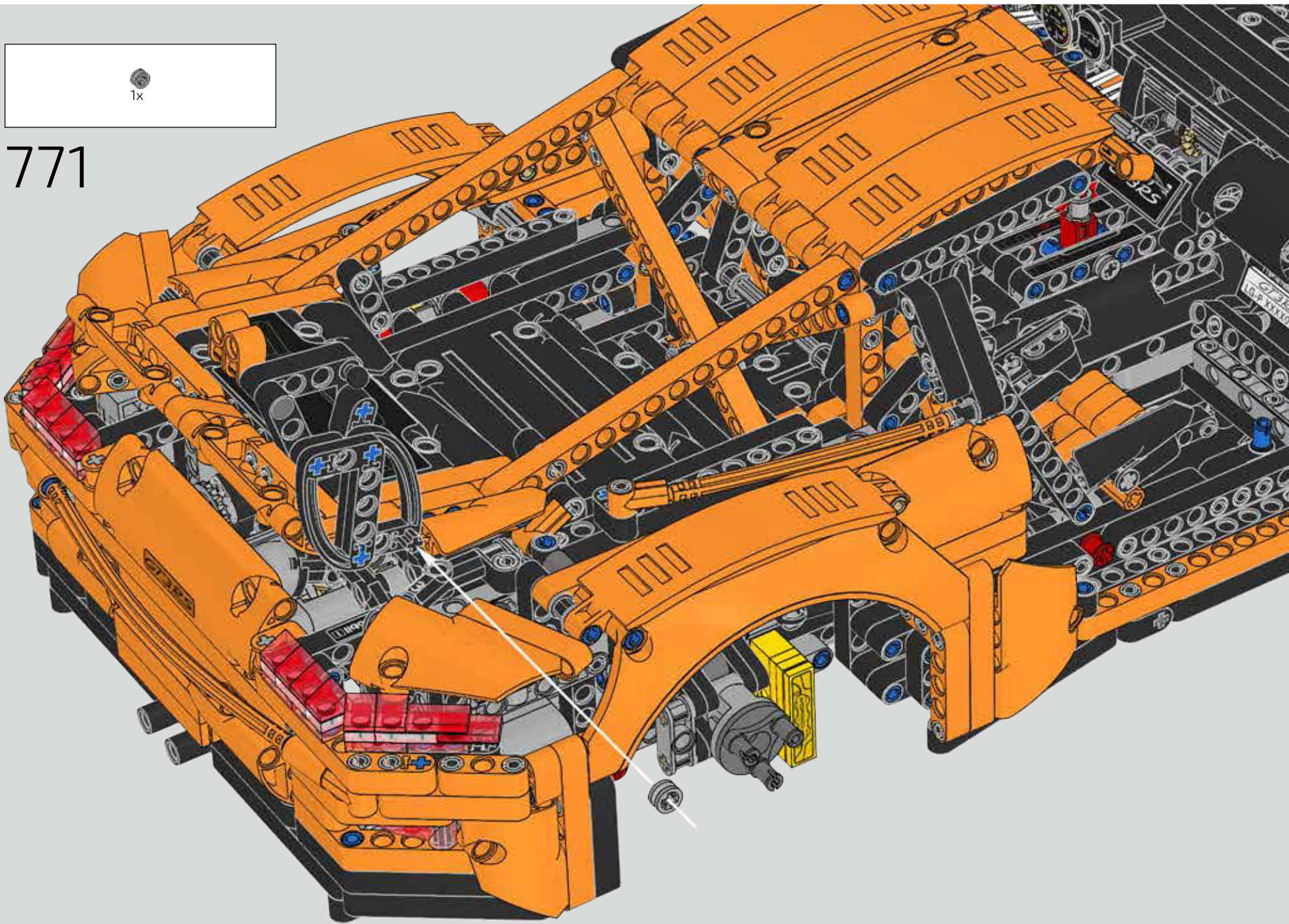

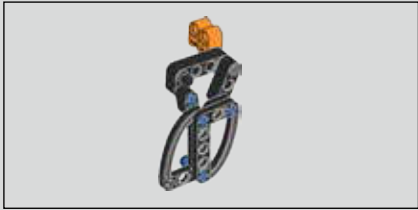

772

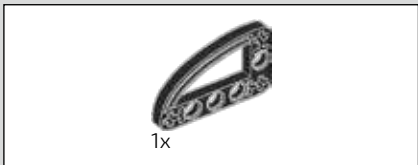
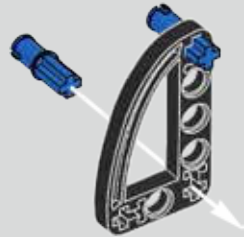

773

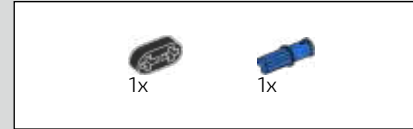

774



775



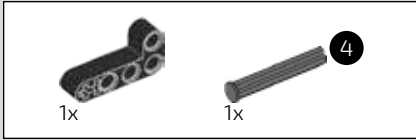

776

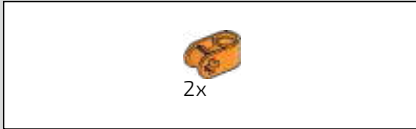
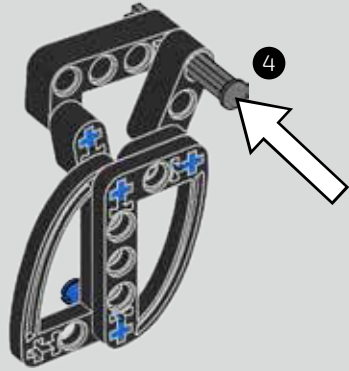

777

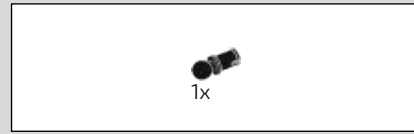

778



779

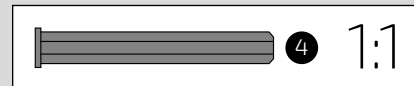
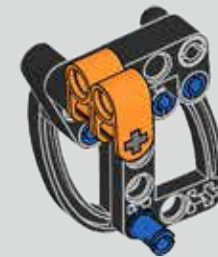
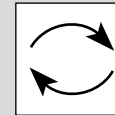



780

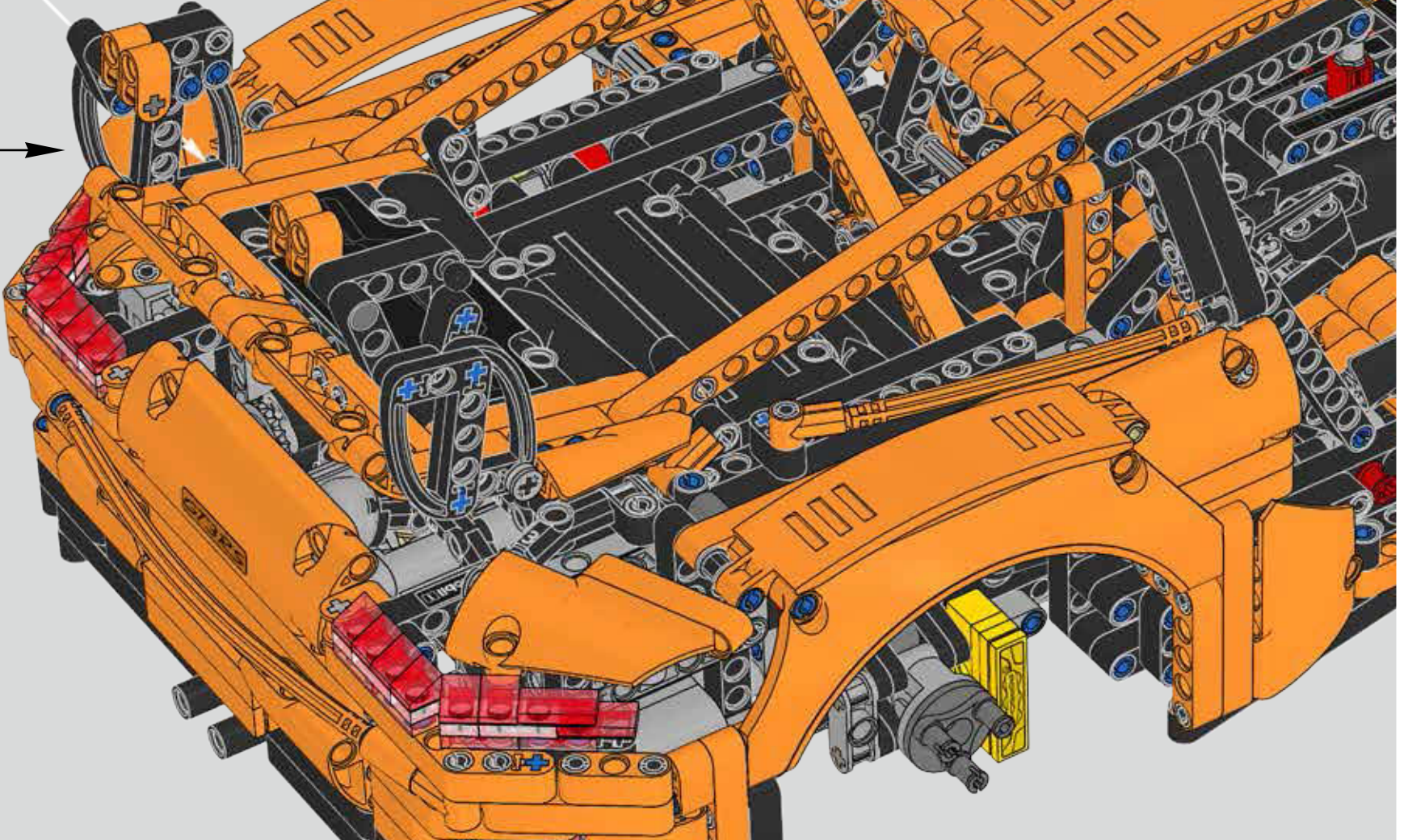

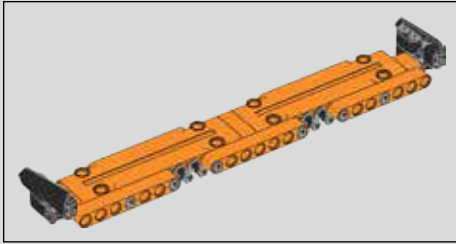

781

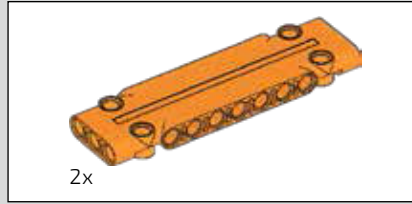
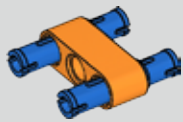

2x

782

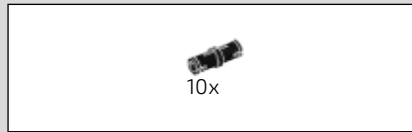
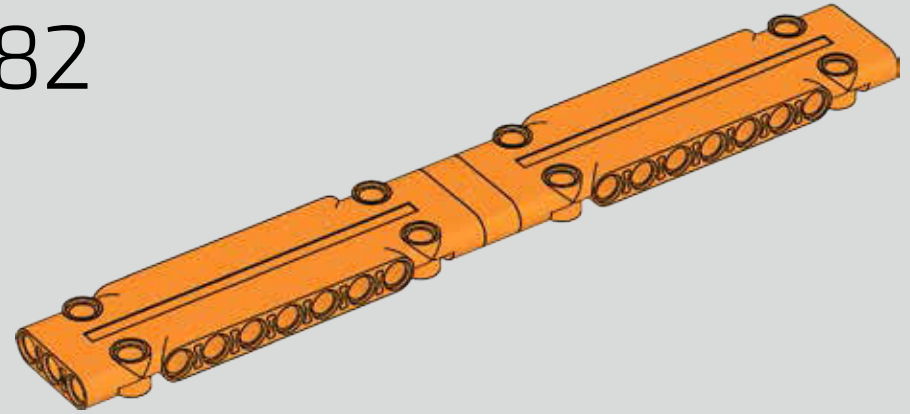

10x

783

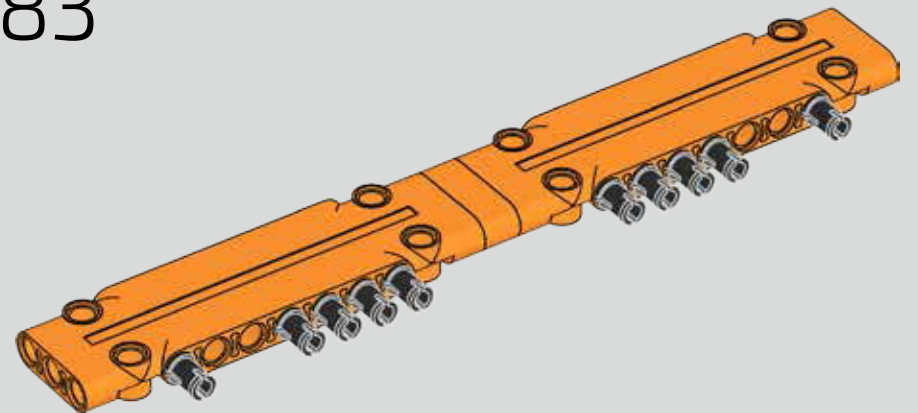

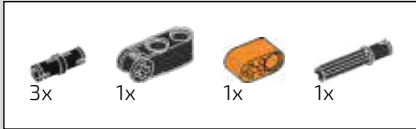

784

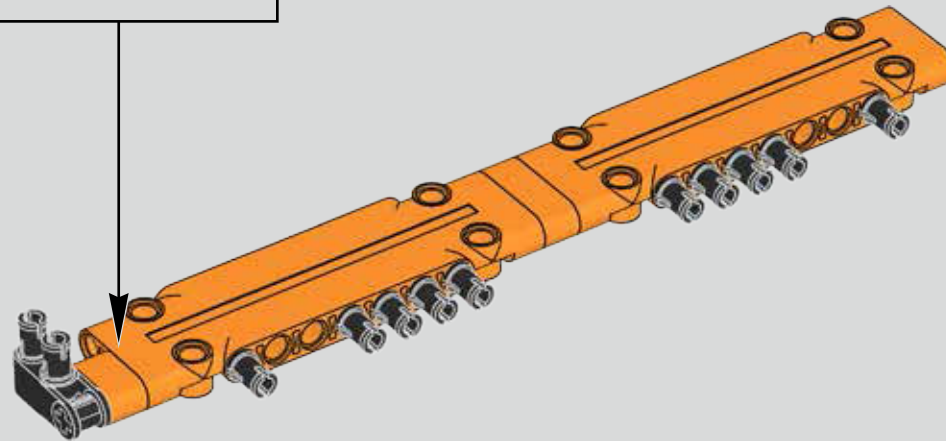
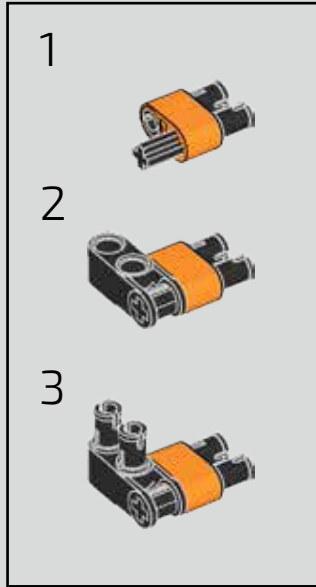

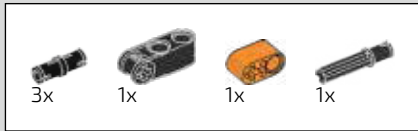

785

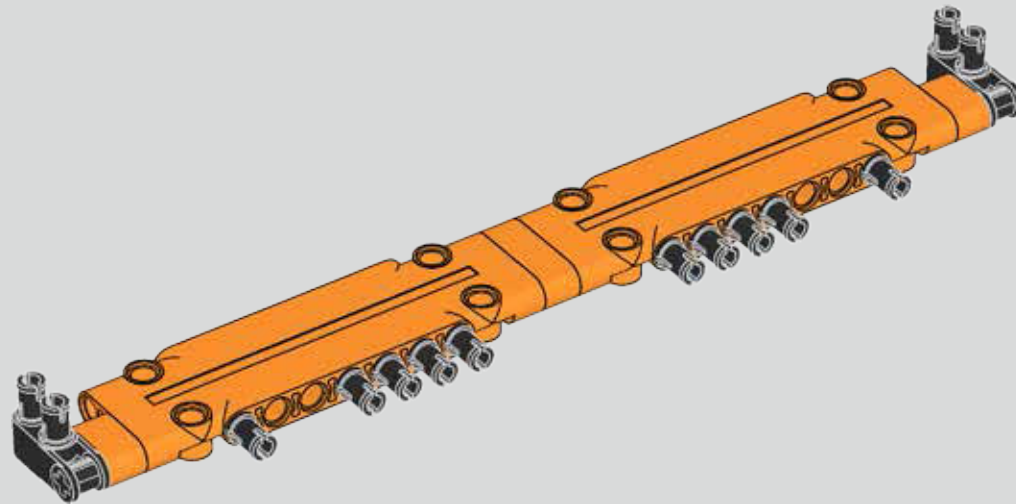
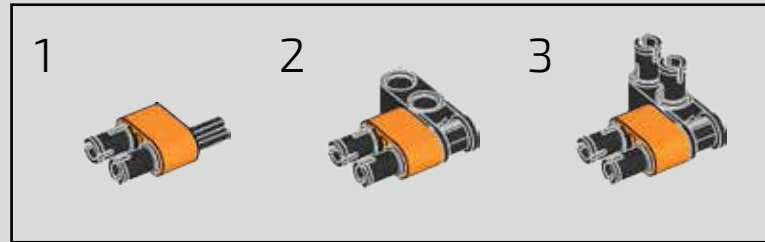

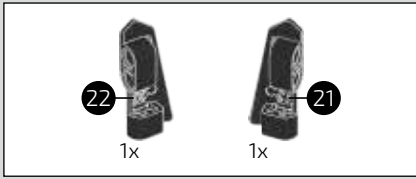

786

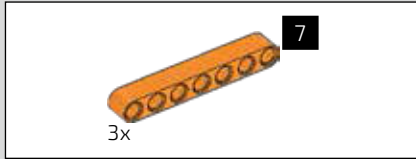
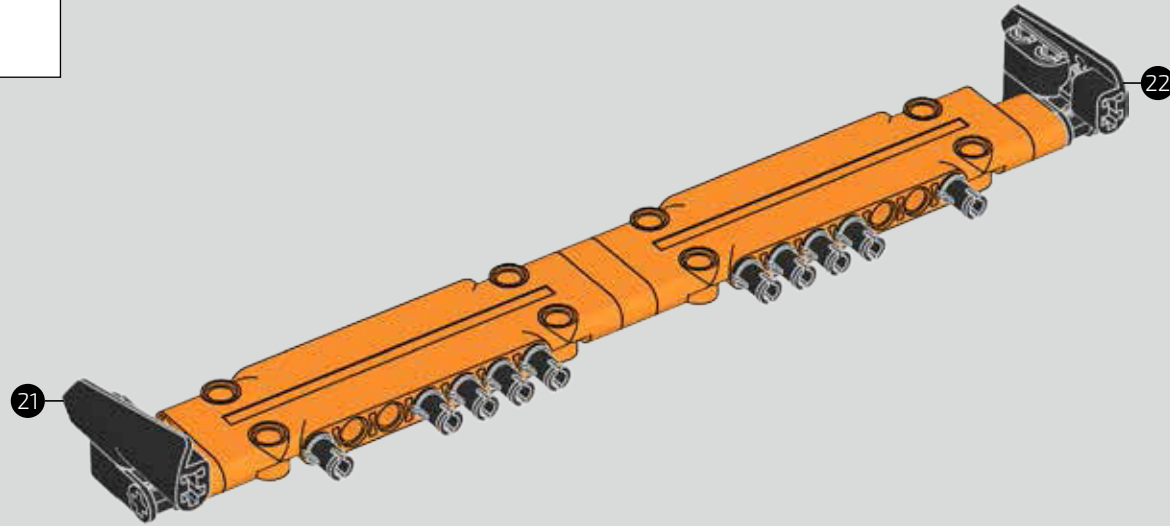

787

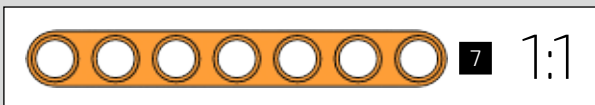
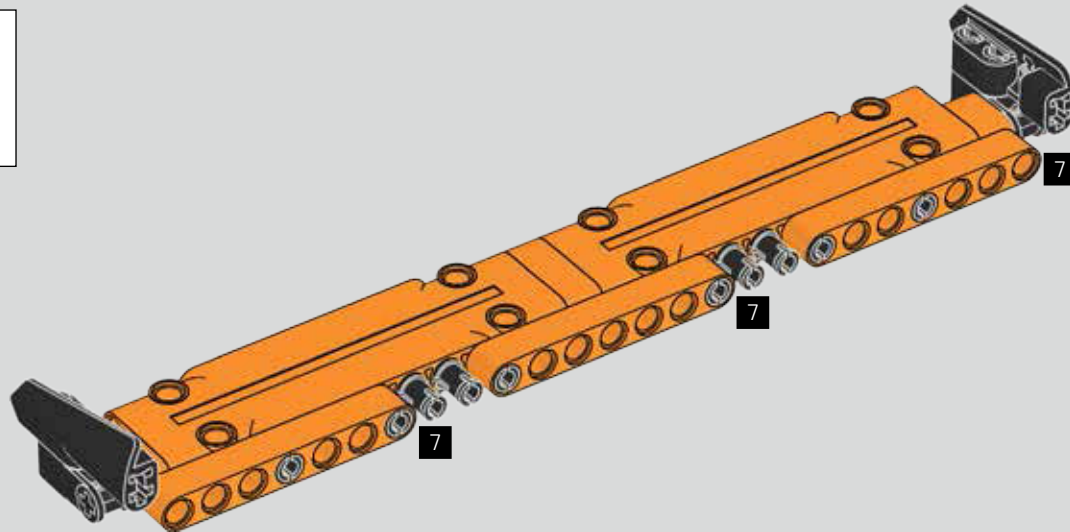

788

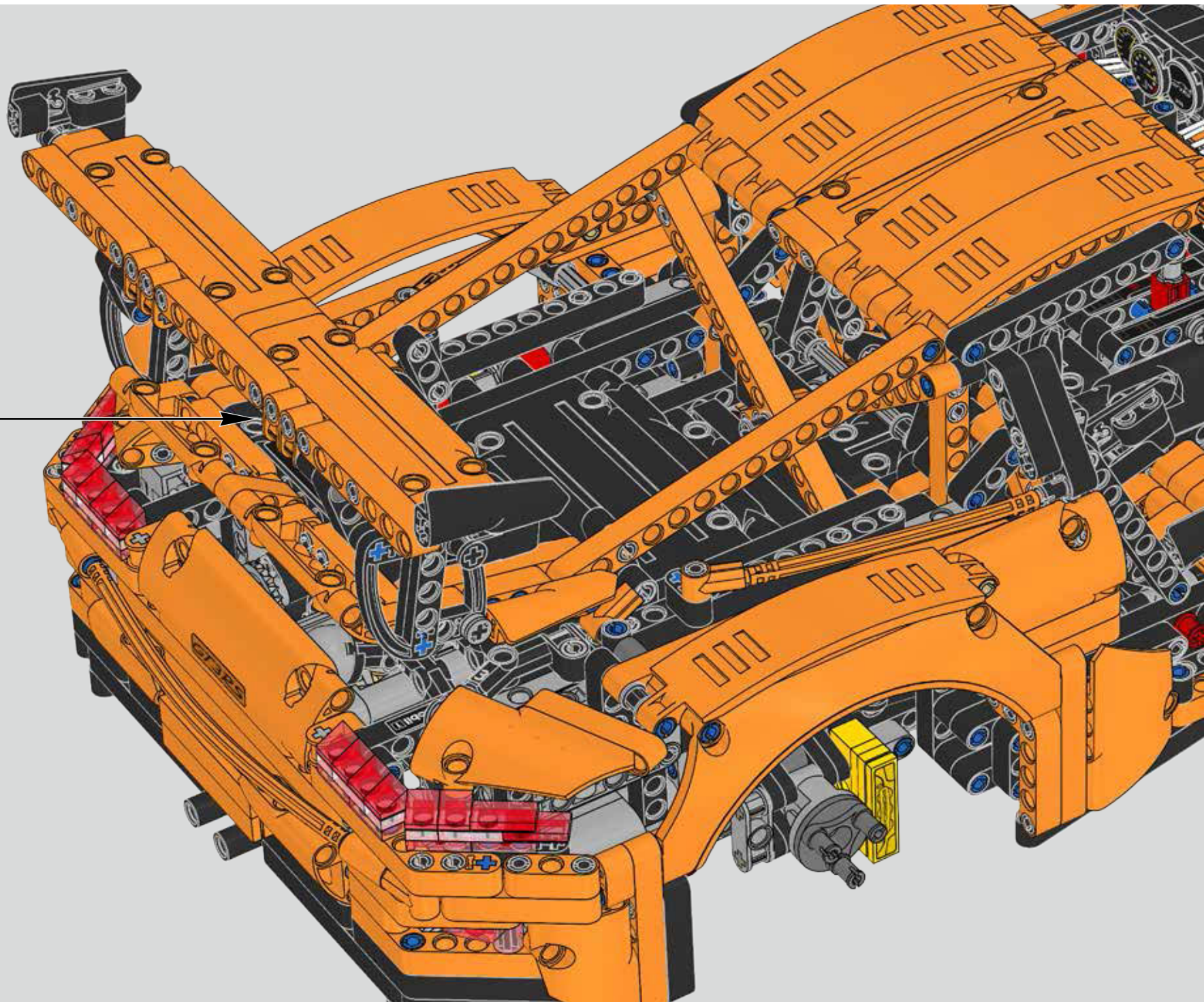

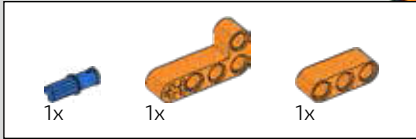

789

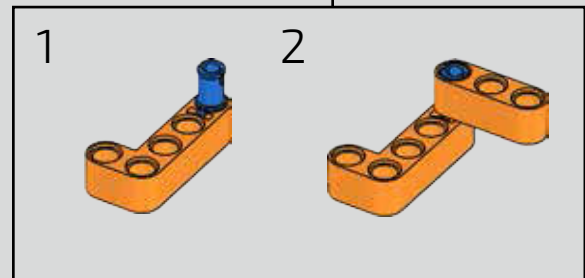
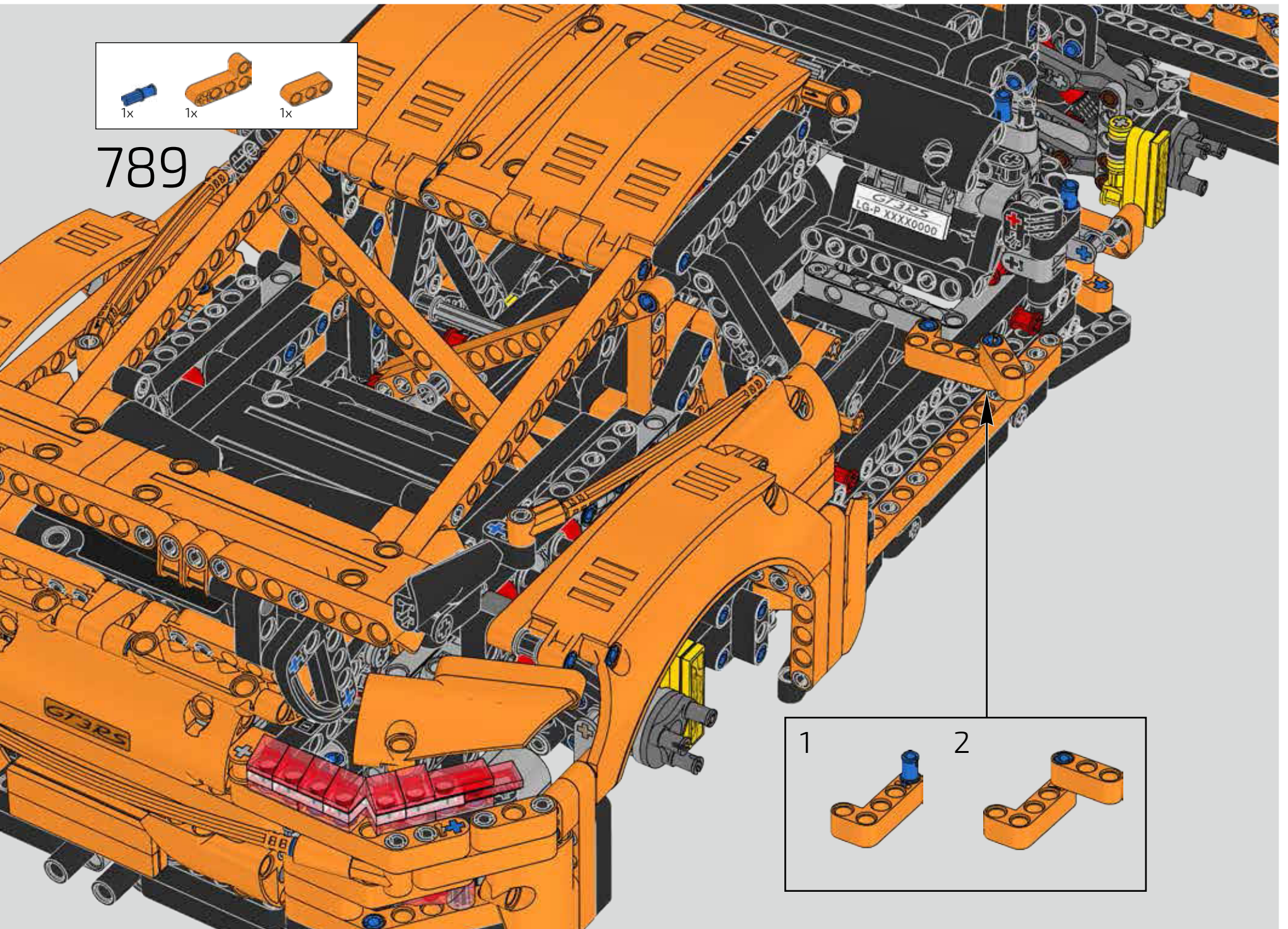

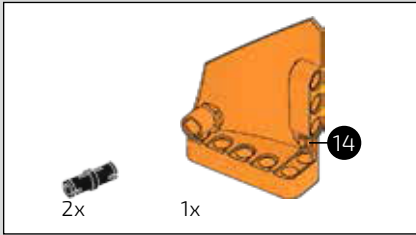
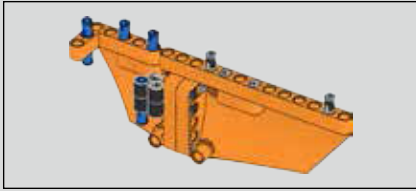

790

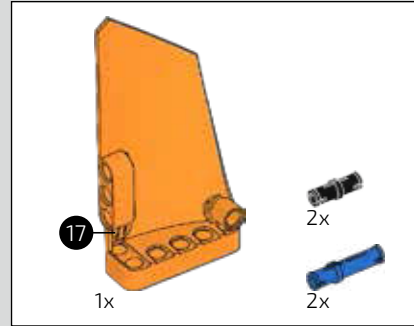
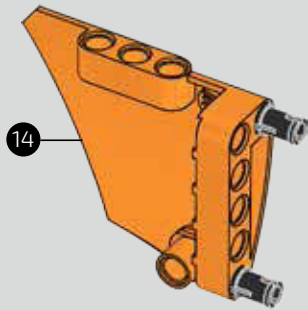

791

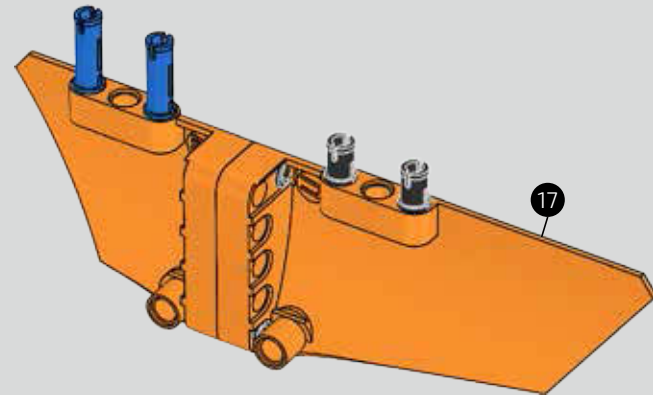

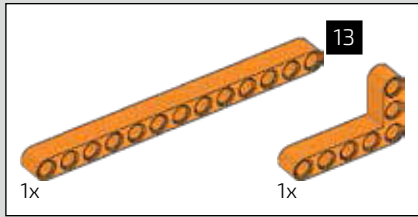

792

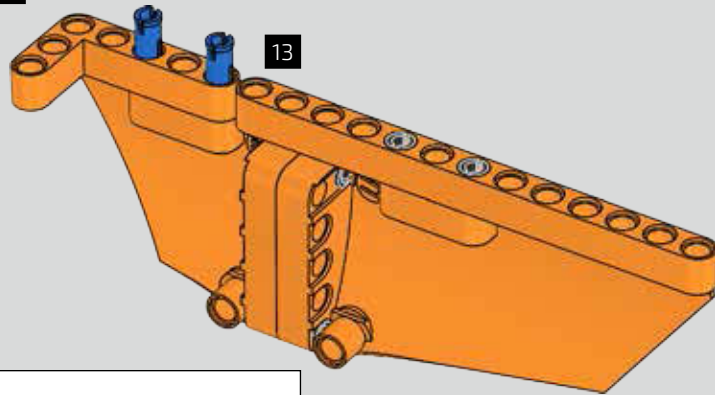

793

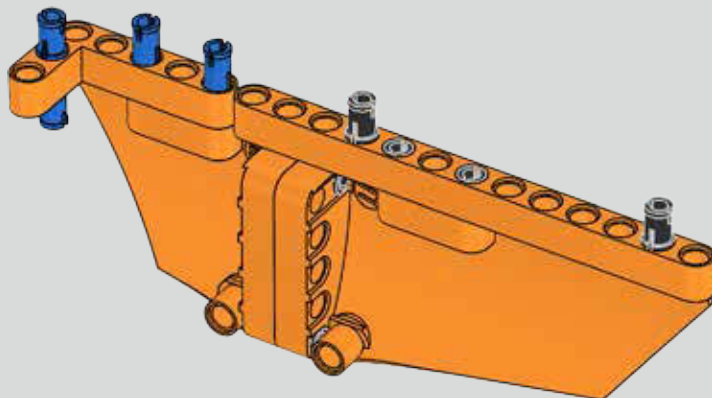

794

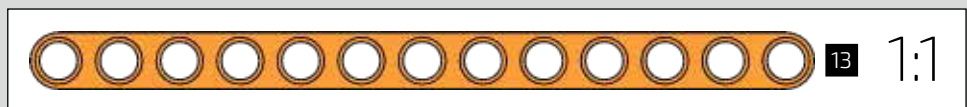
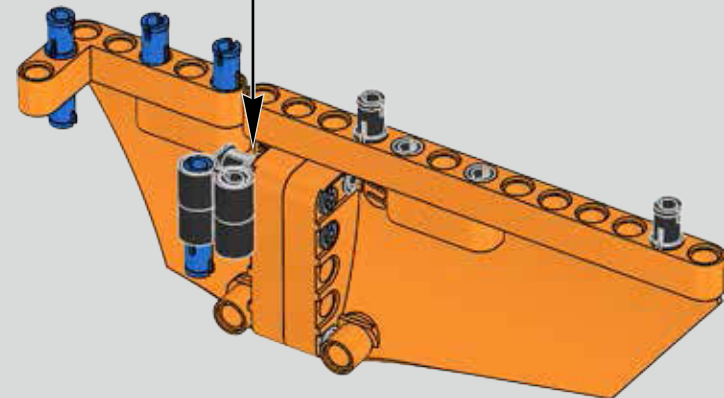
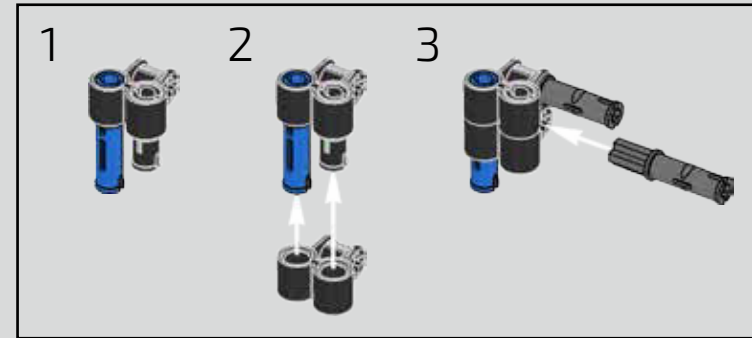

795

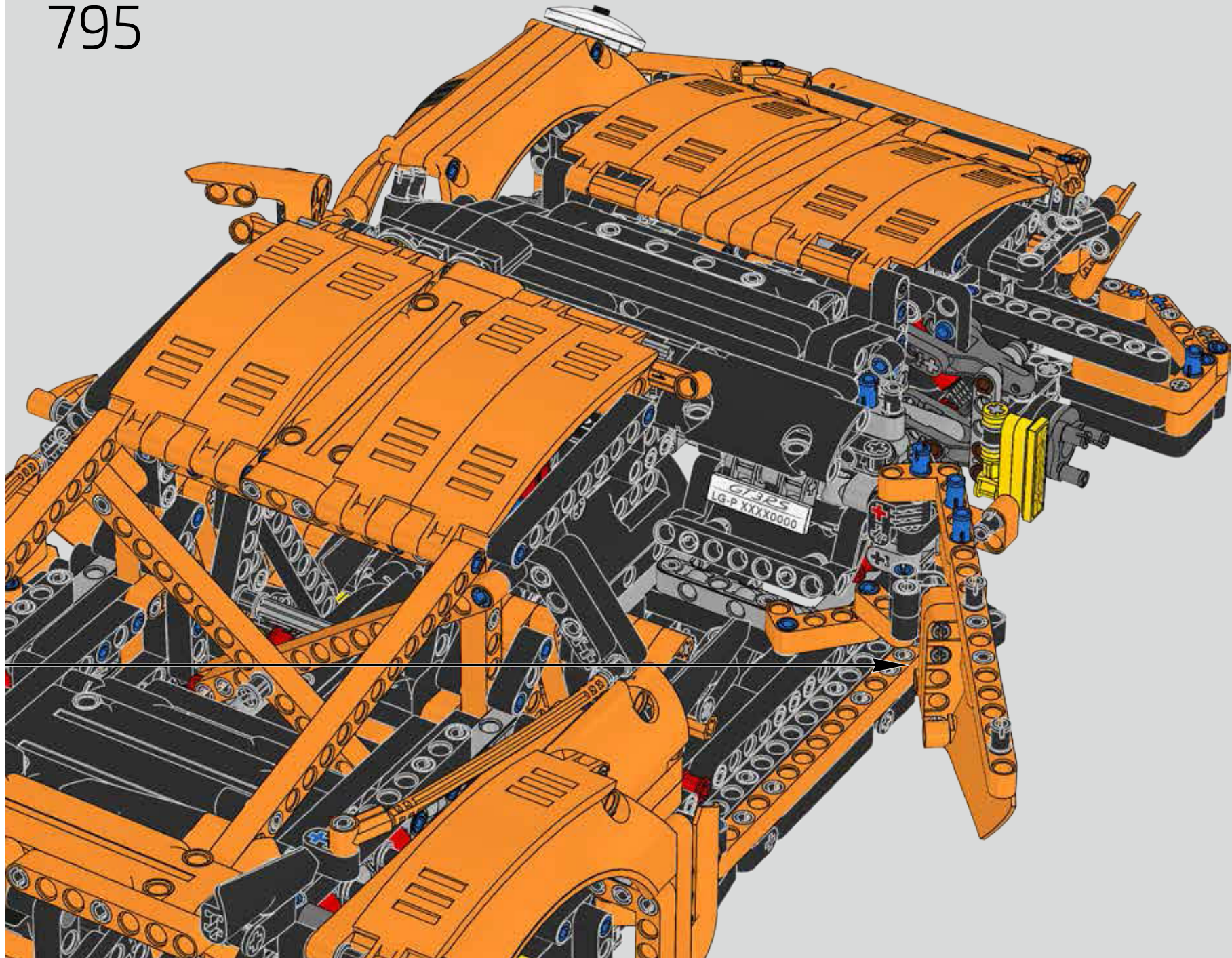

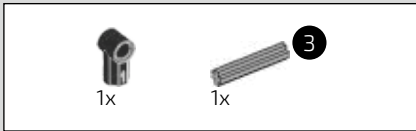

796



797

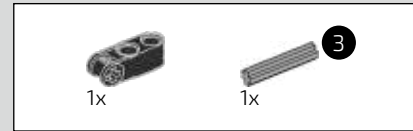
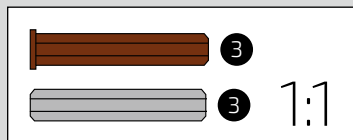

798

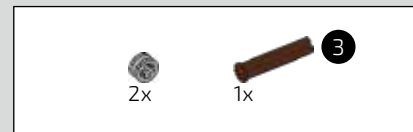
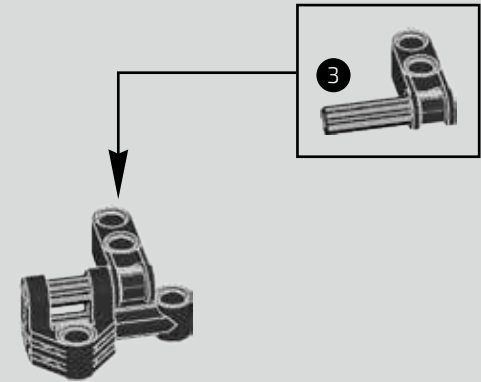

799

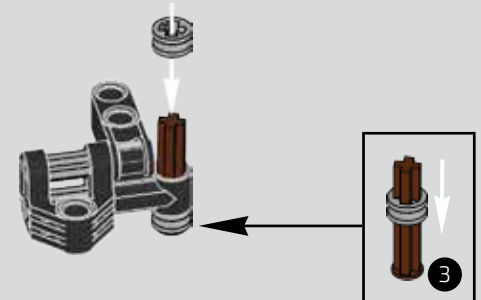

800

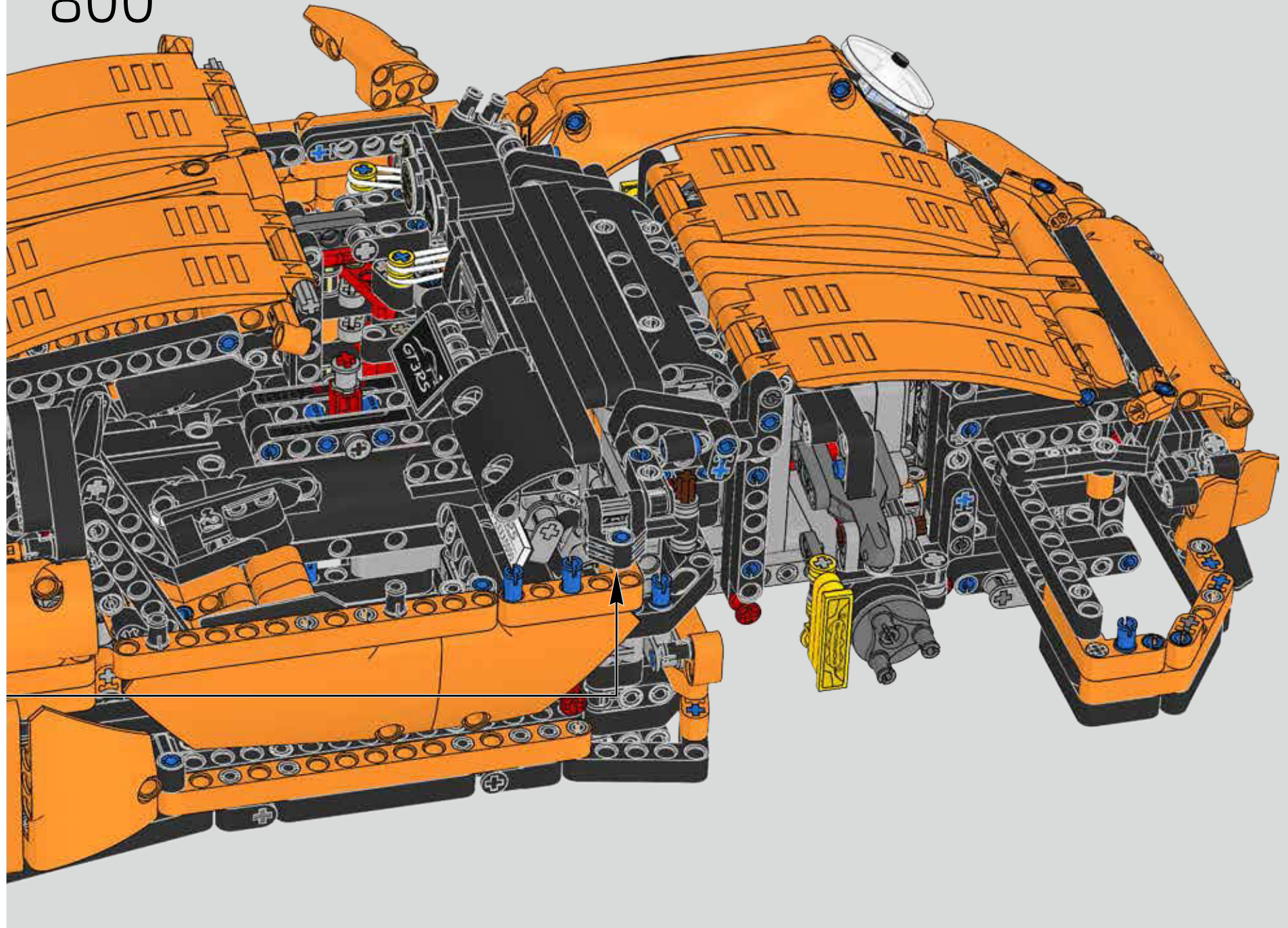

801

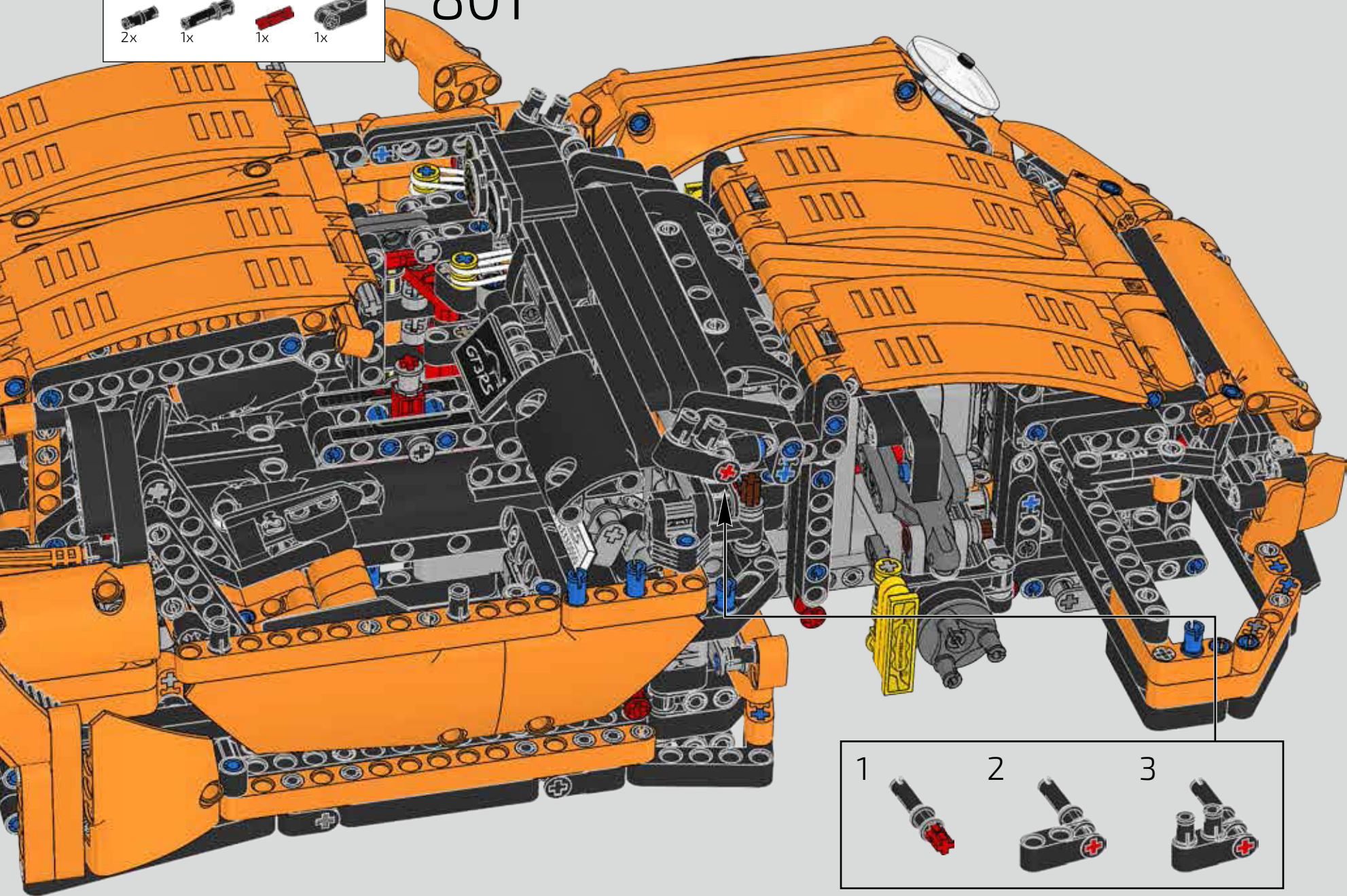
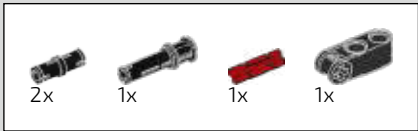



802

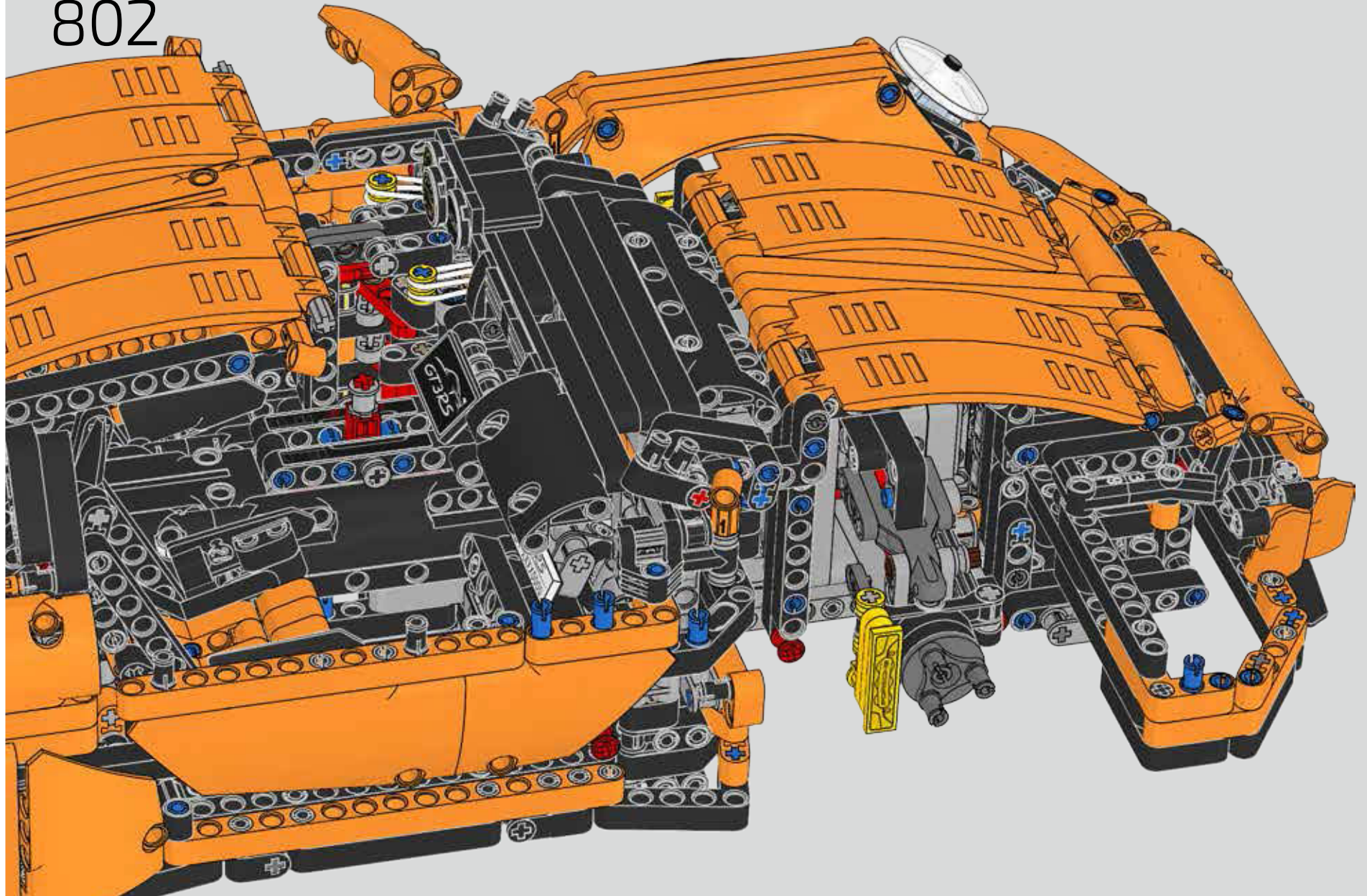

803

- 2x 
- 1x 
- 2x 
- 1x 
- 1x 

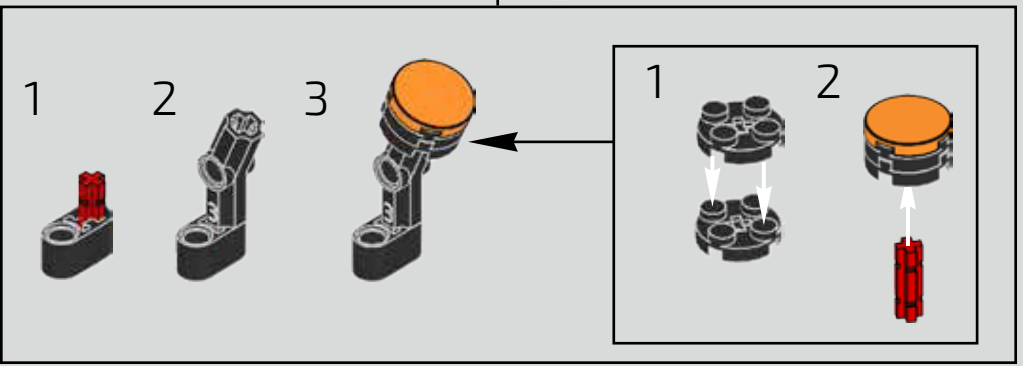
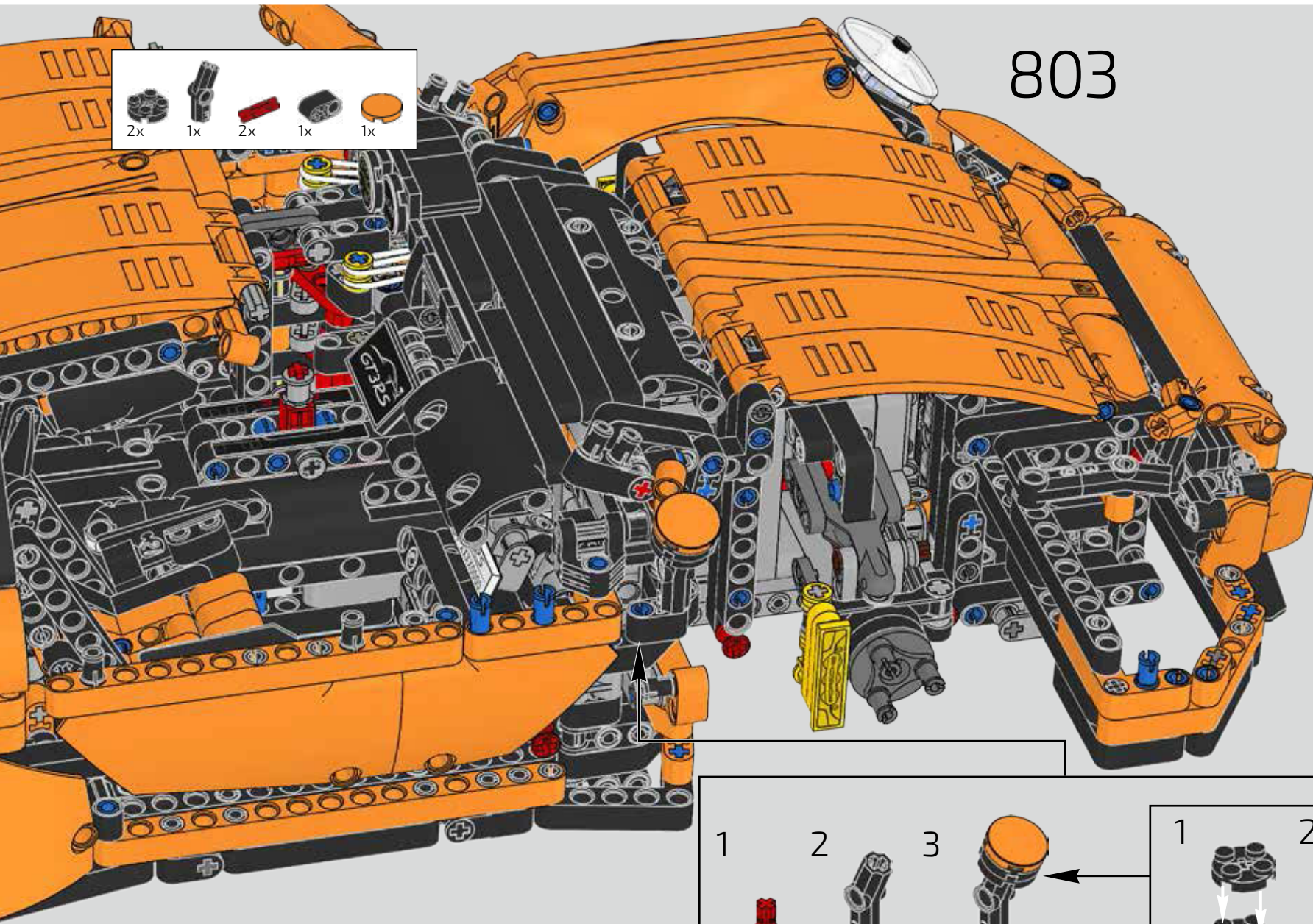

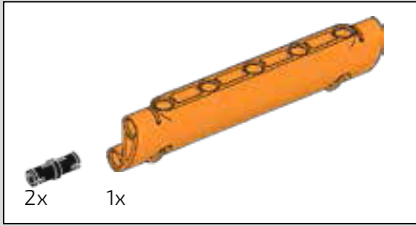
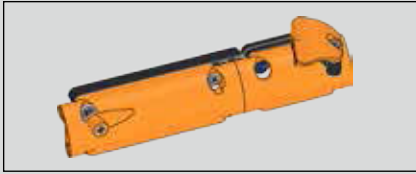

804

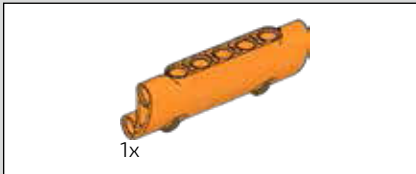
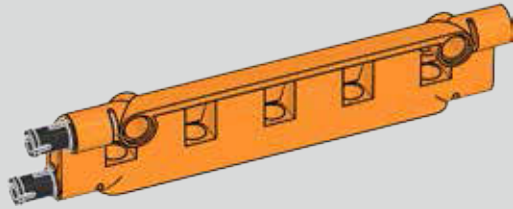

805

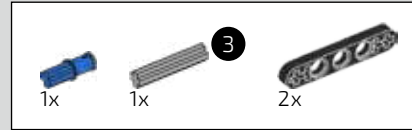
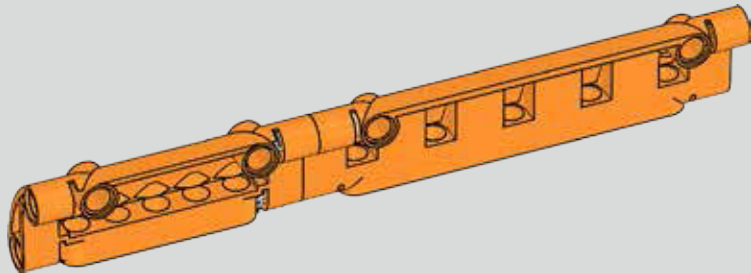

806

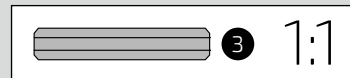
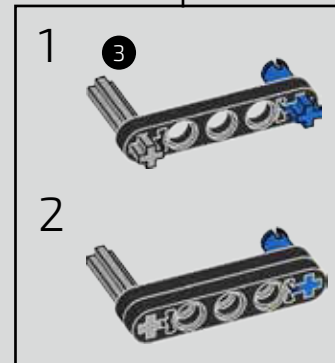
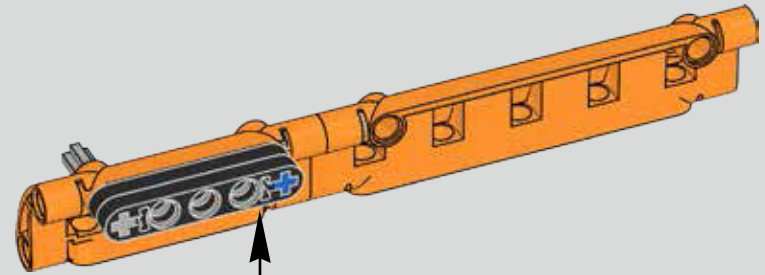

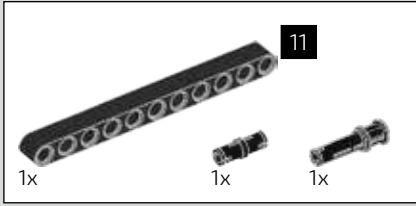

807

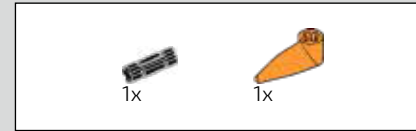
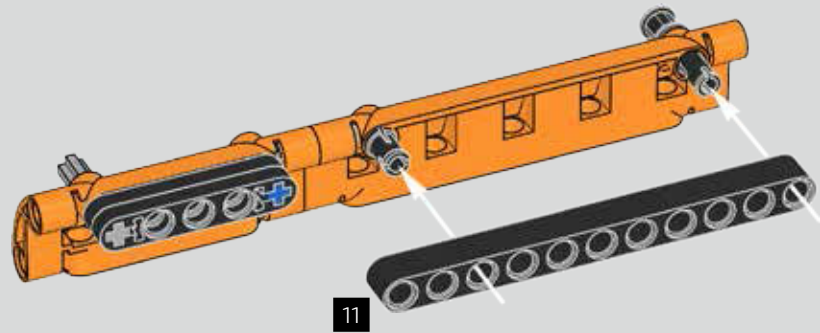

808

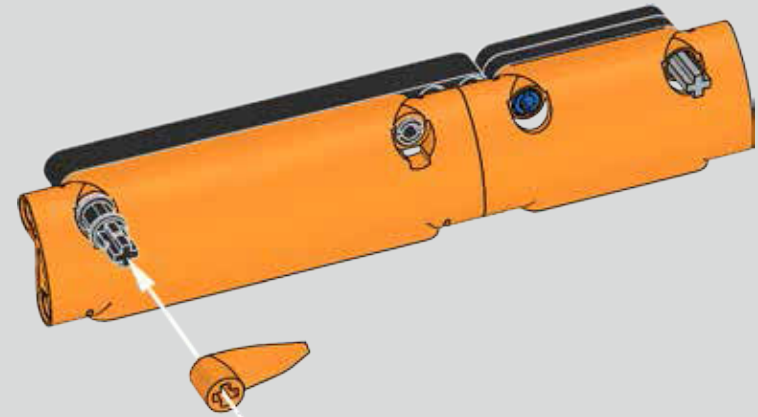
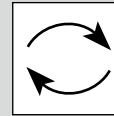

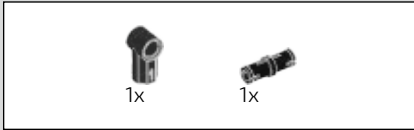

809

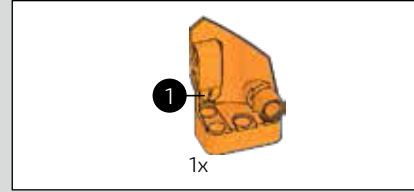
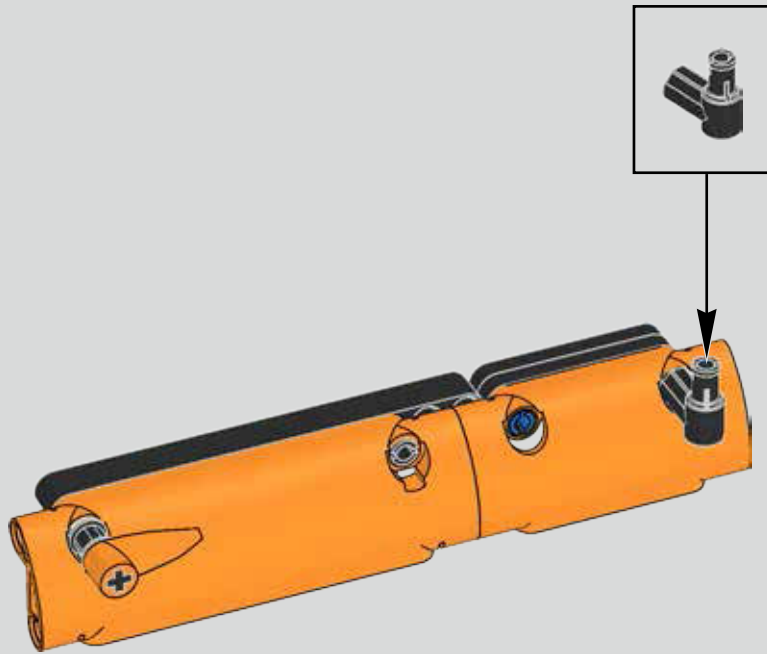

810

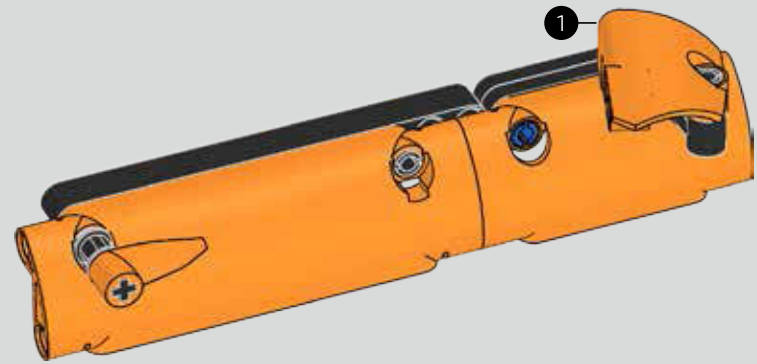

811

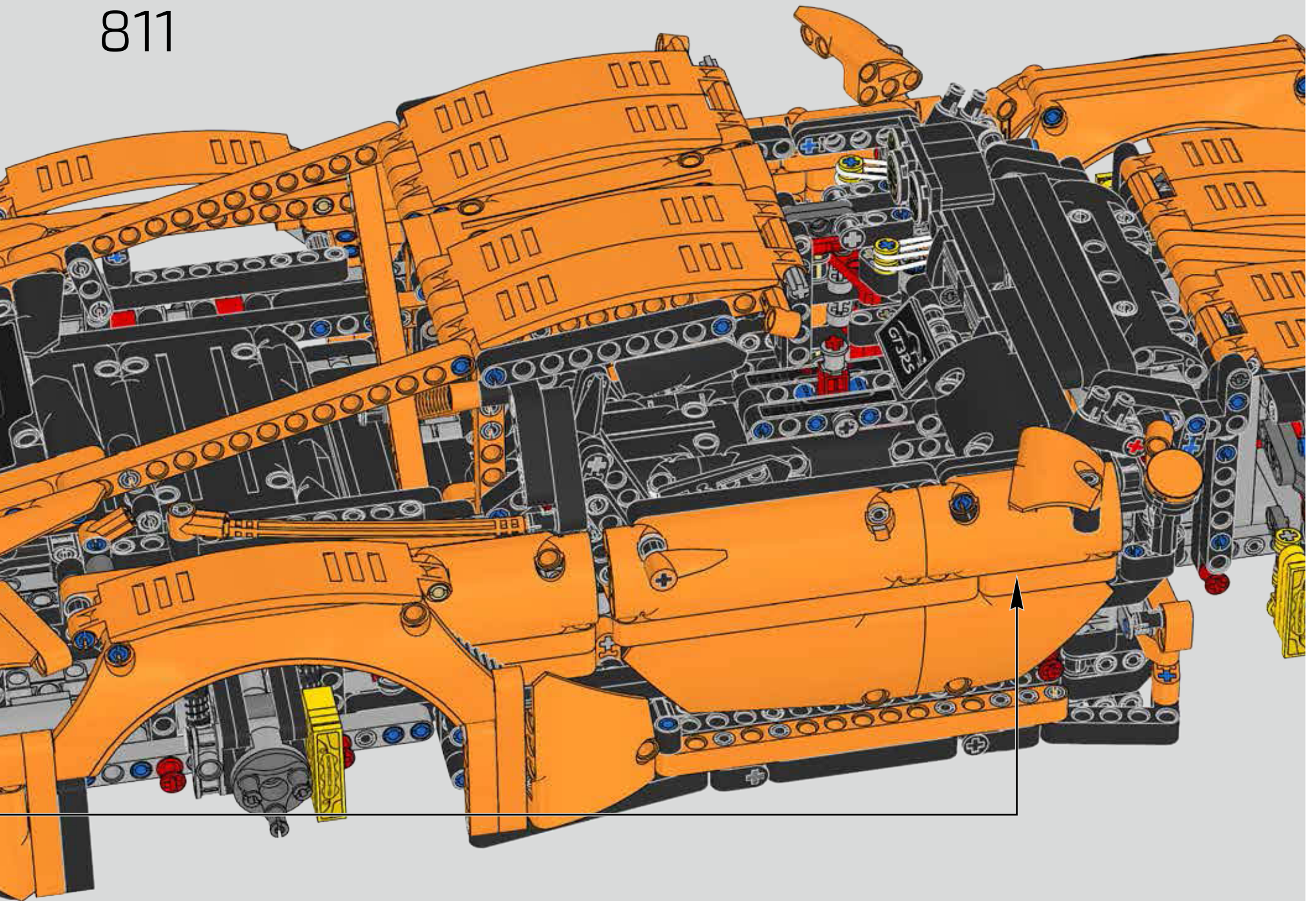

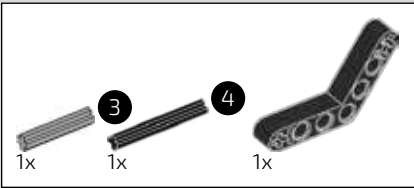

812

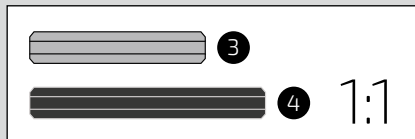
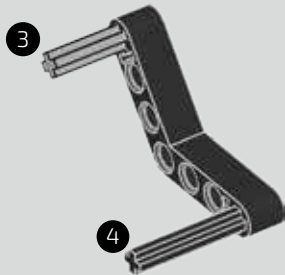

813

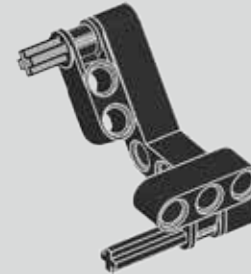

814



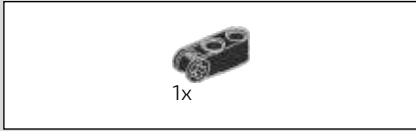

815



816

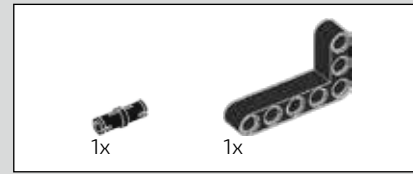

817

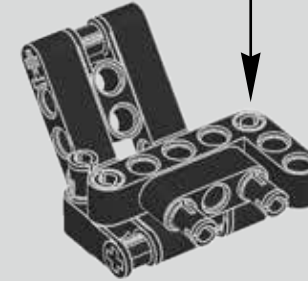
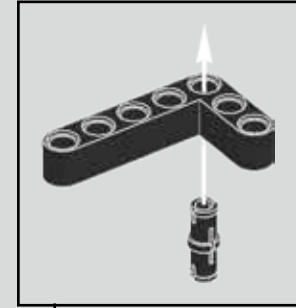

818

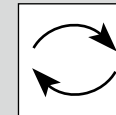

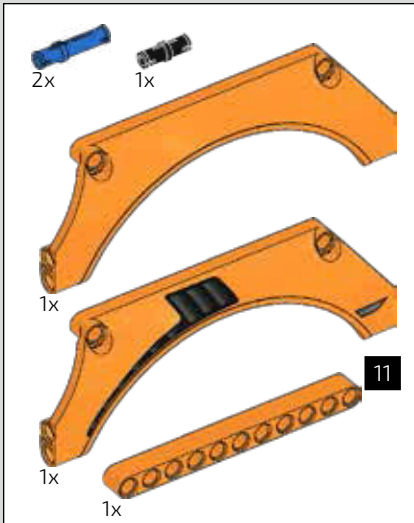

819

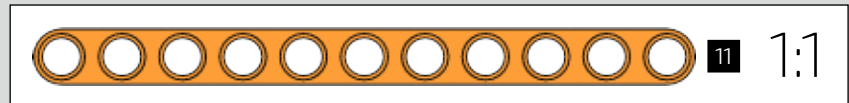
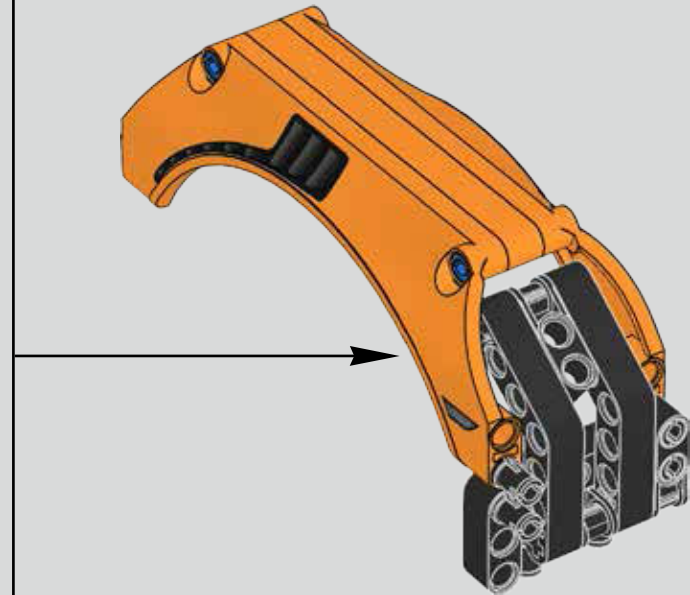
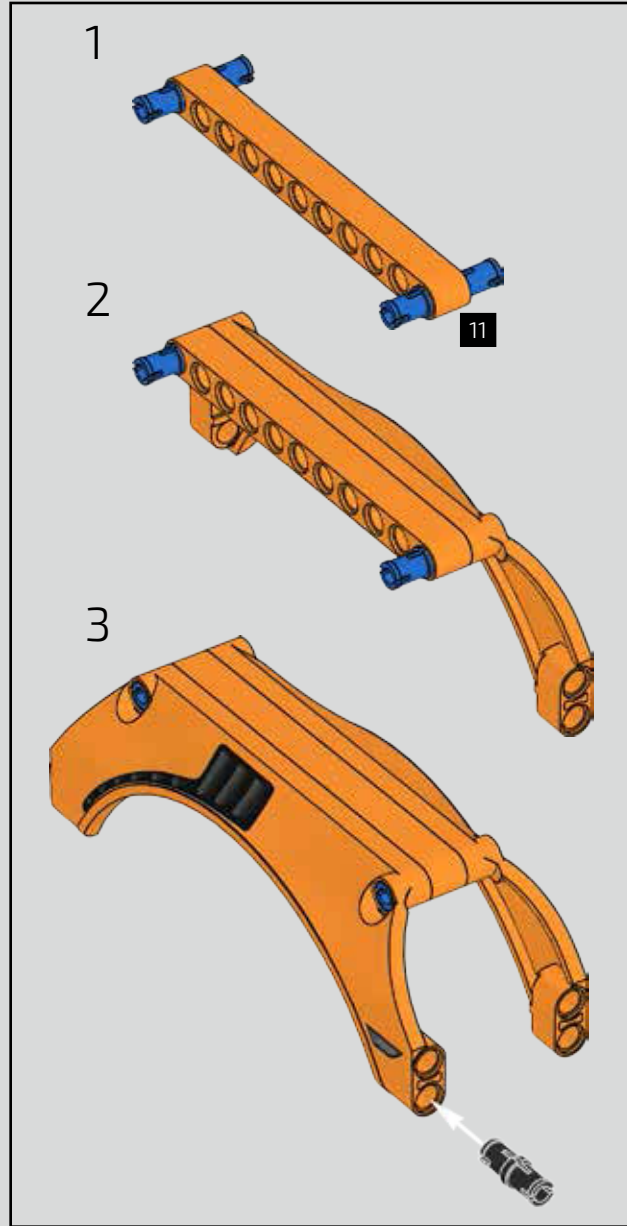

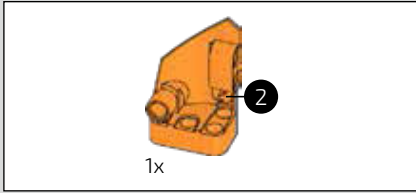

820

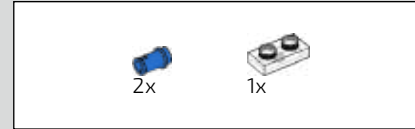

821



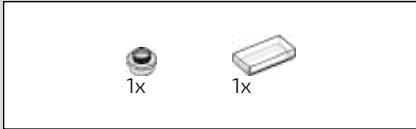

822

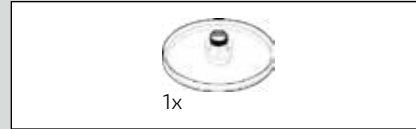
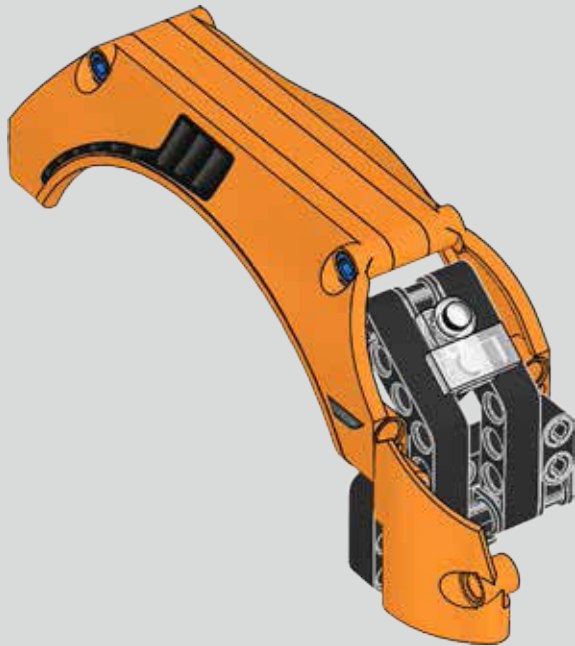

823



824

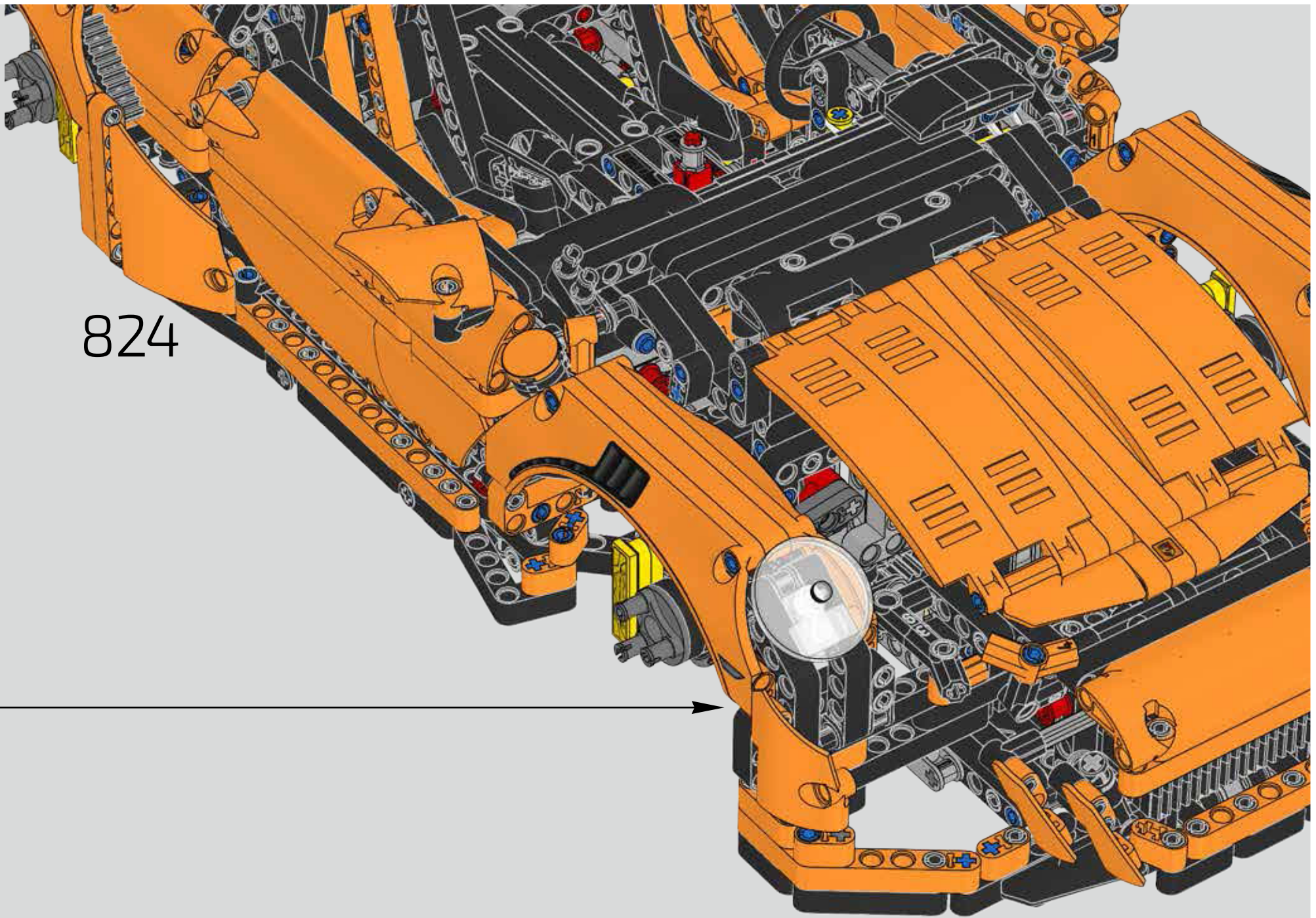

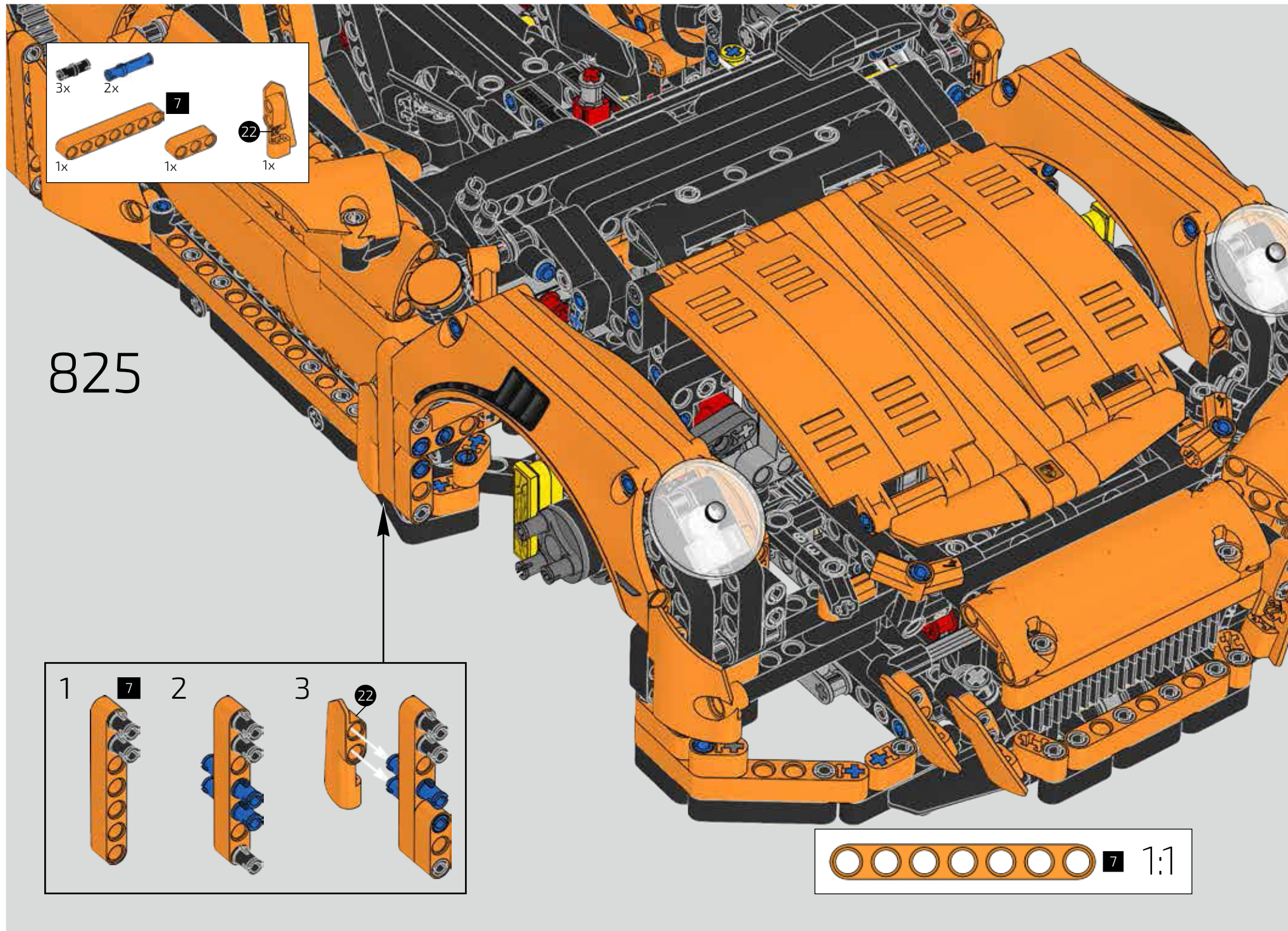

- 3x [grey pin]
- 2x [blue pin]
- 7 [orange 7-hole beam]
- 22 [orange 3-hole beam]
- 1x [orange 7-hole beam]
- 1x [orange 3-hole beam]
- 1x [orange Technic connector]

825

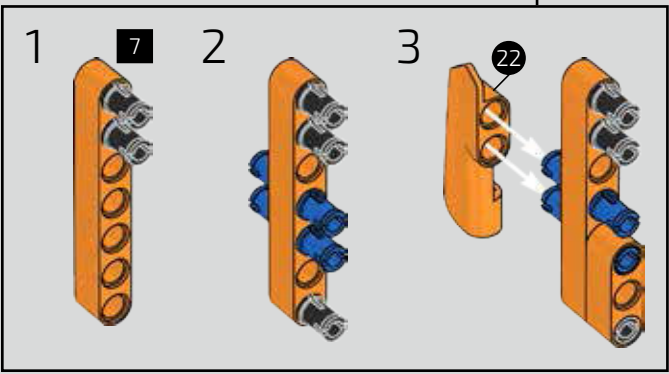

[orange 7-hole beam] 7 1:1

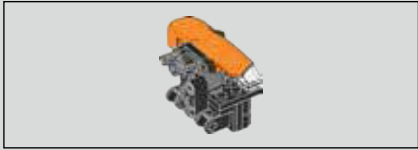

826

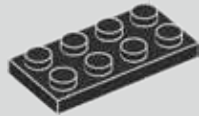

827

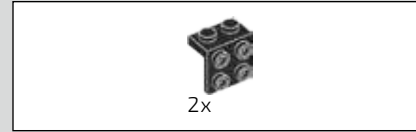
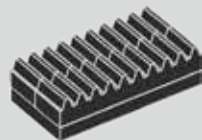

828

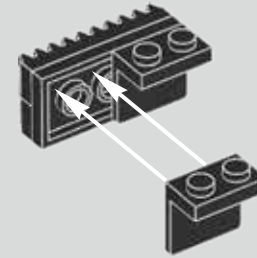
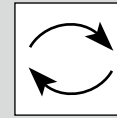

829



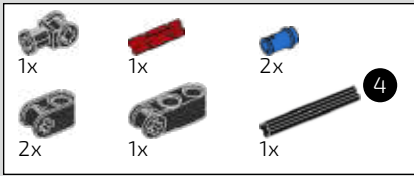

830

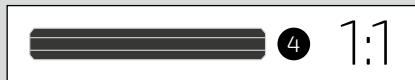
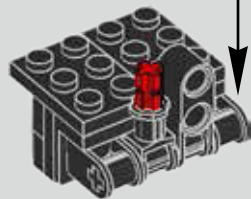
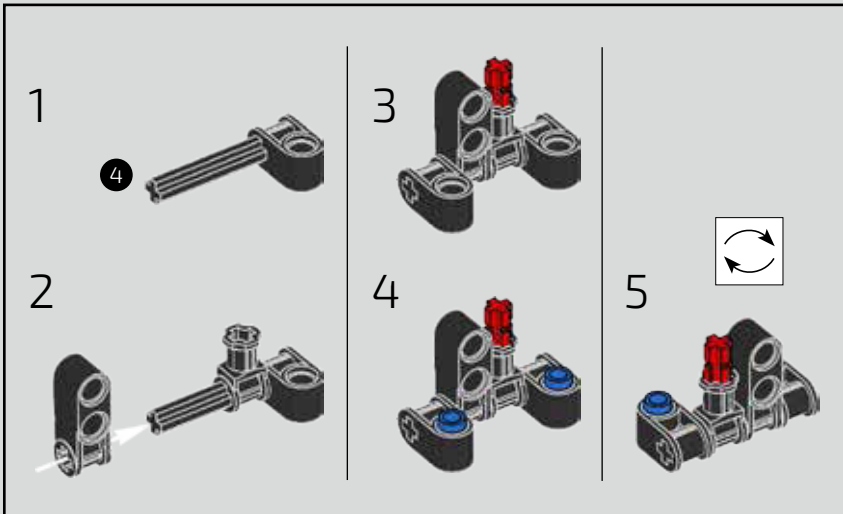

831

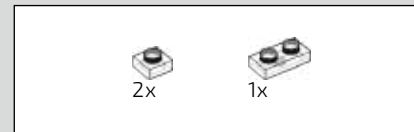
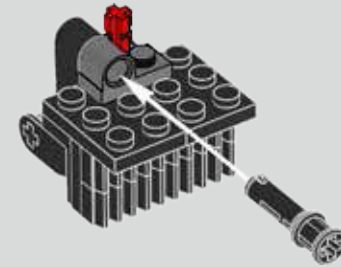
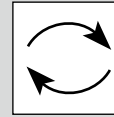

832

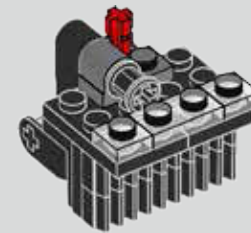

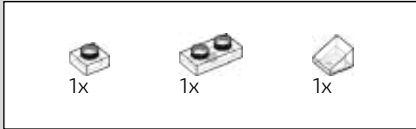

833

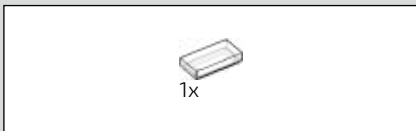
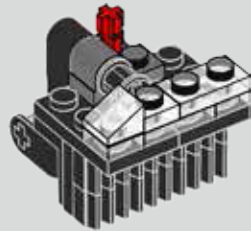

834

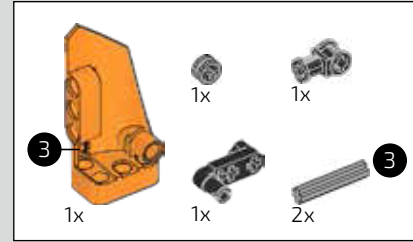
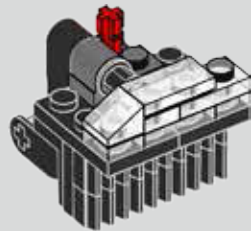

835

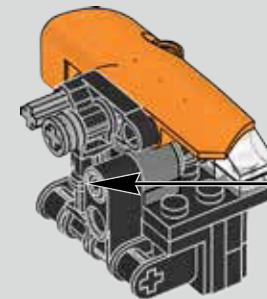
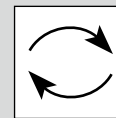
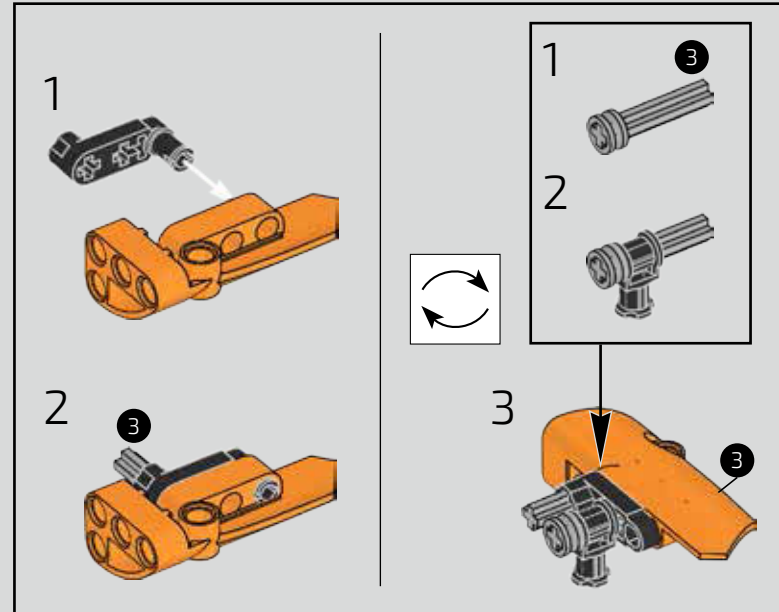
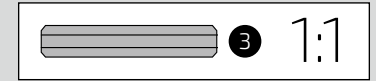

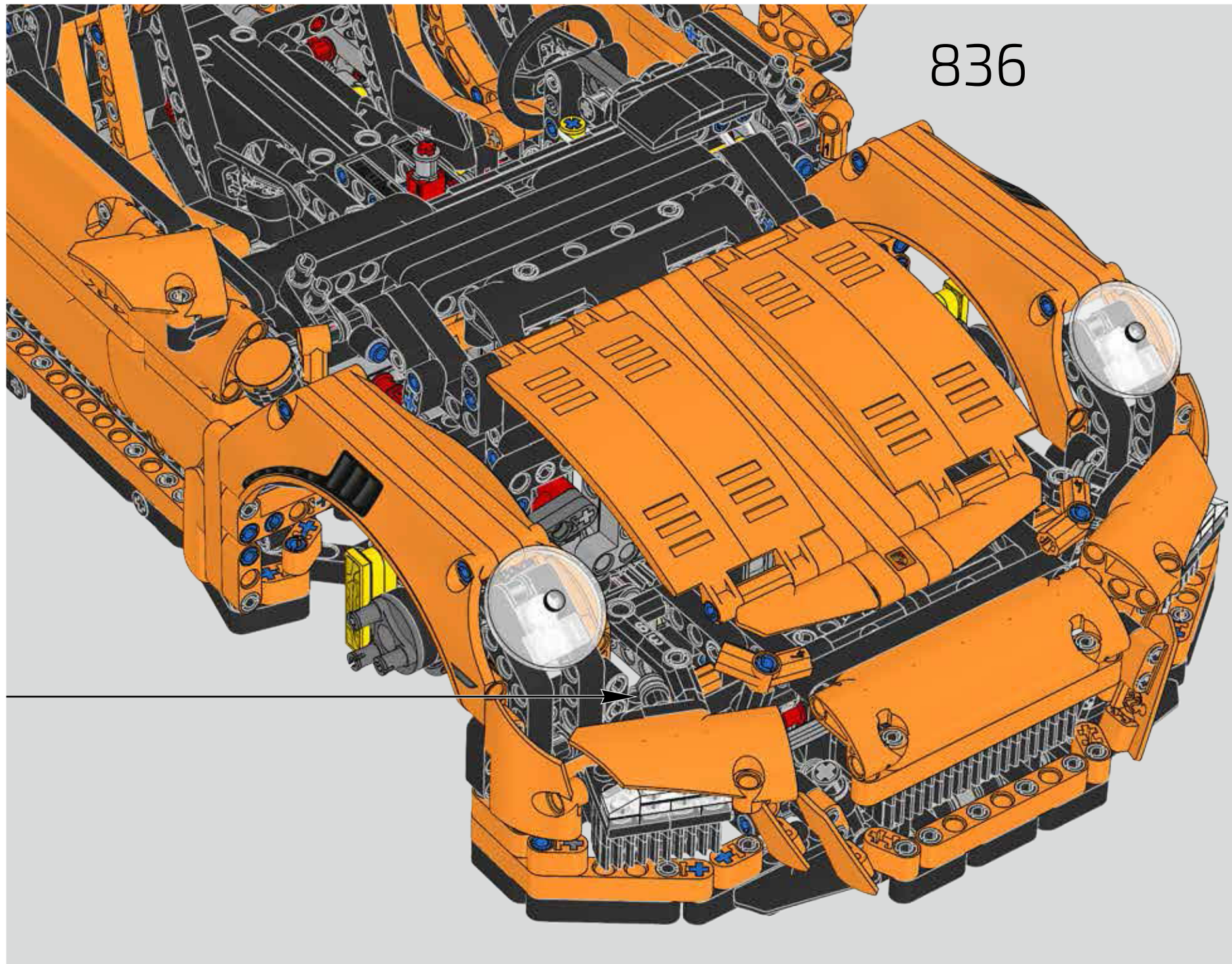

836

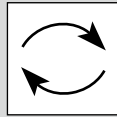
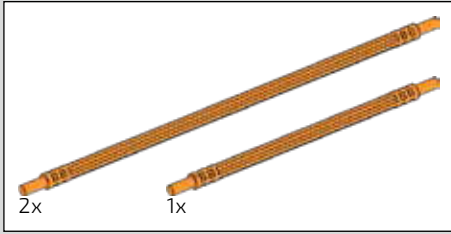

837

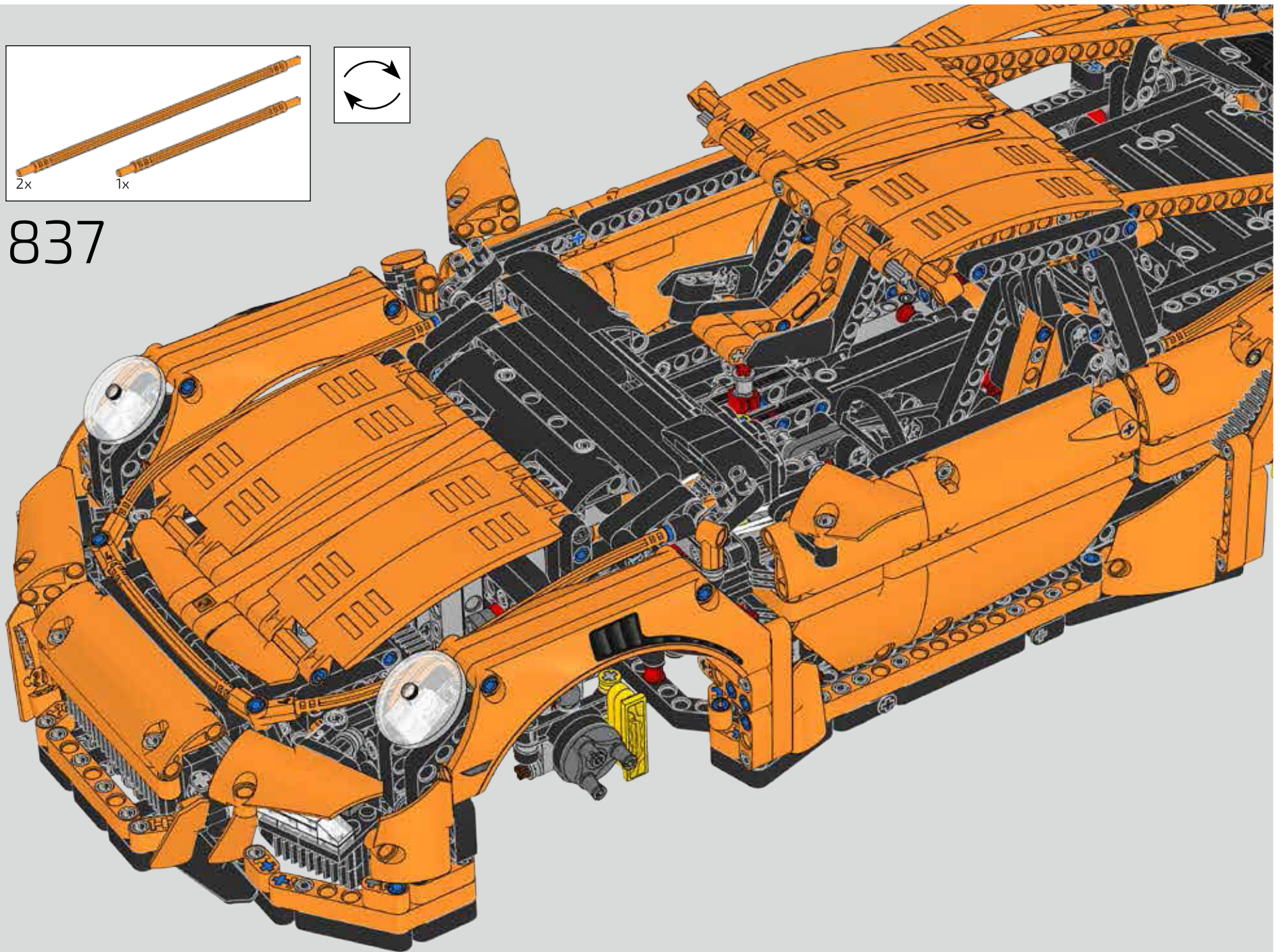

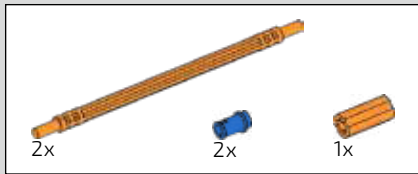

838

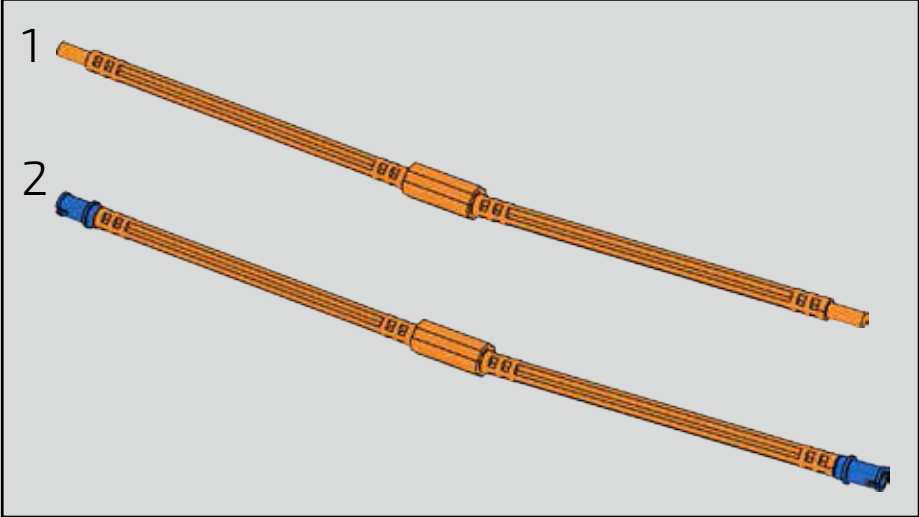
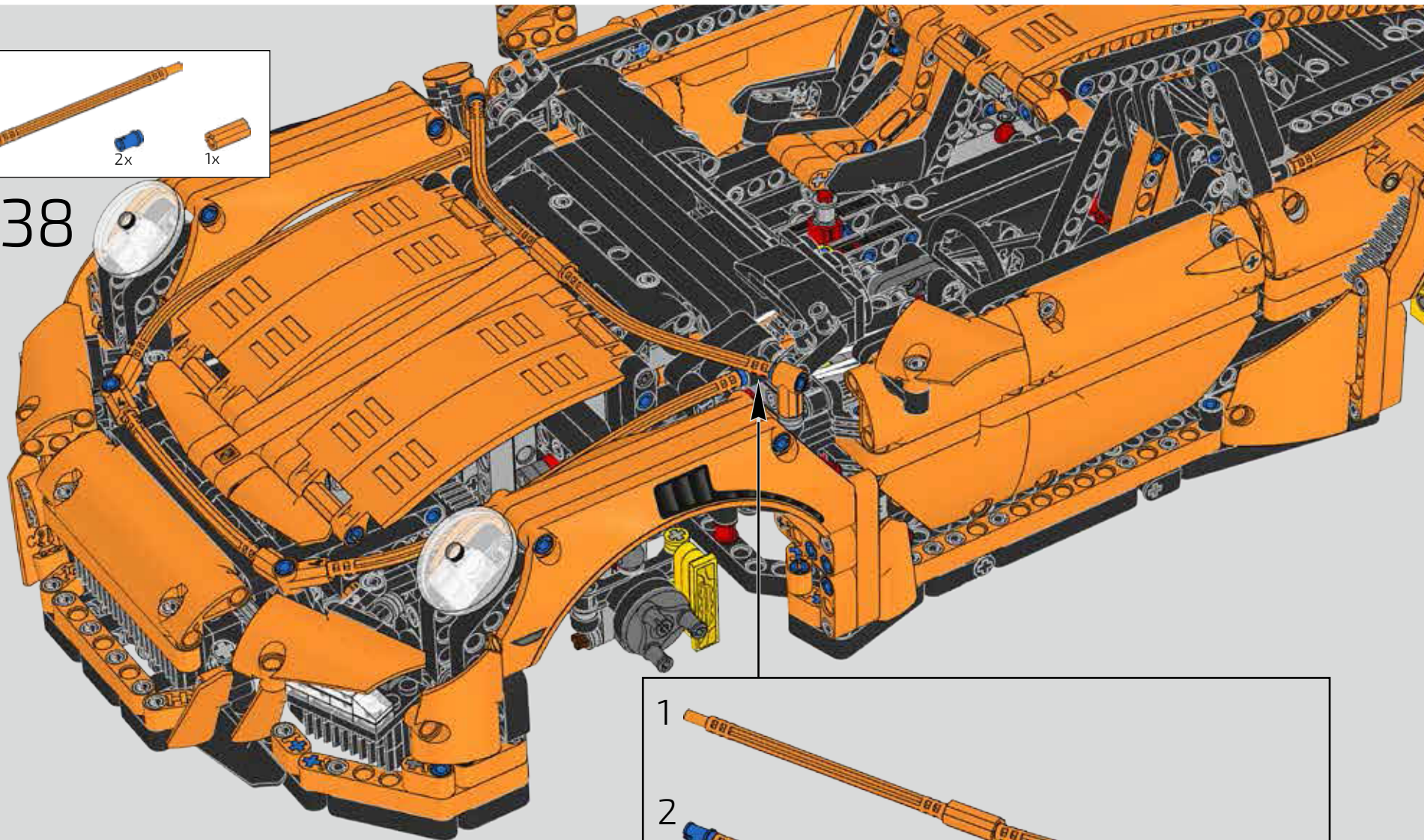

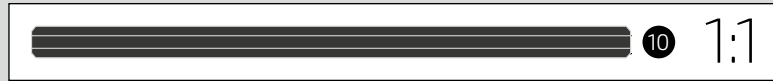
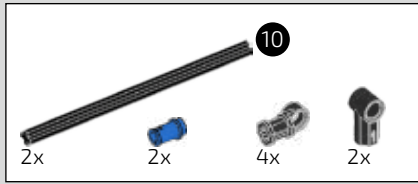

839

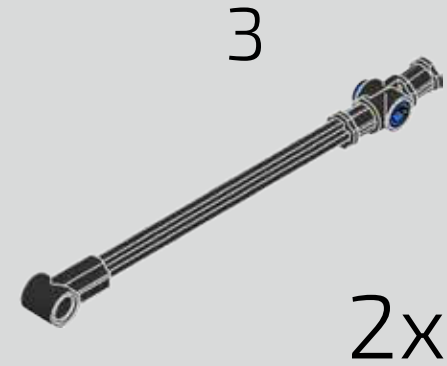
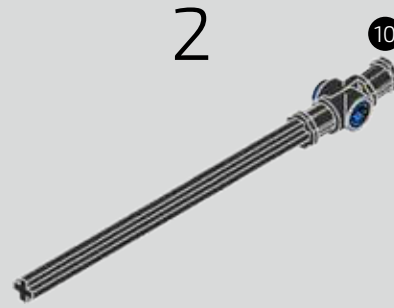
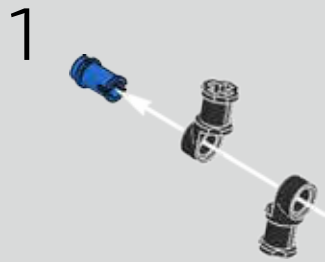

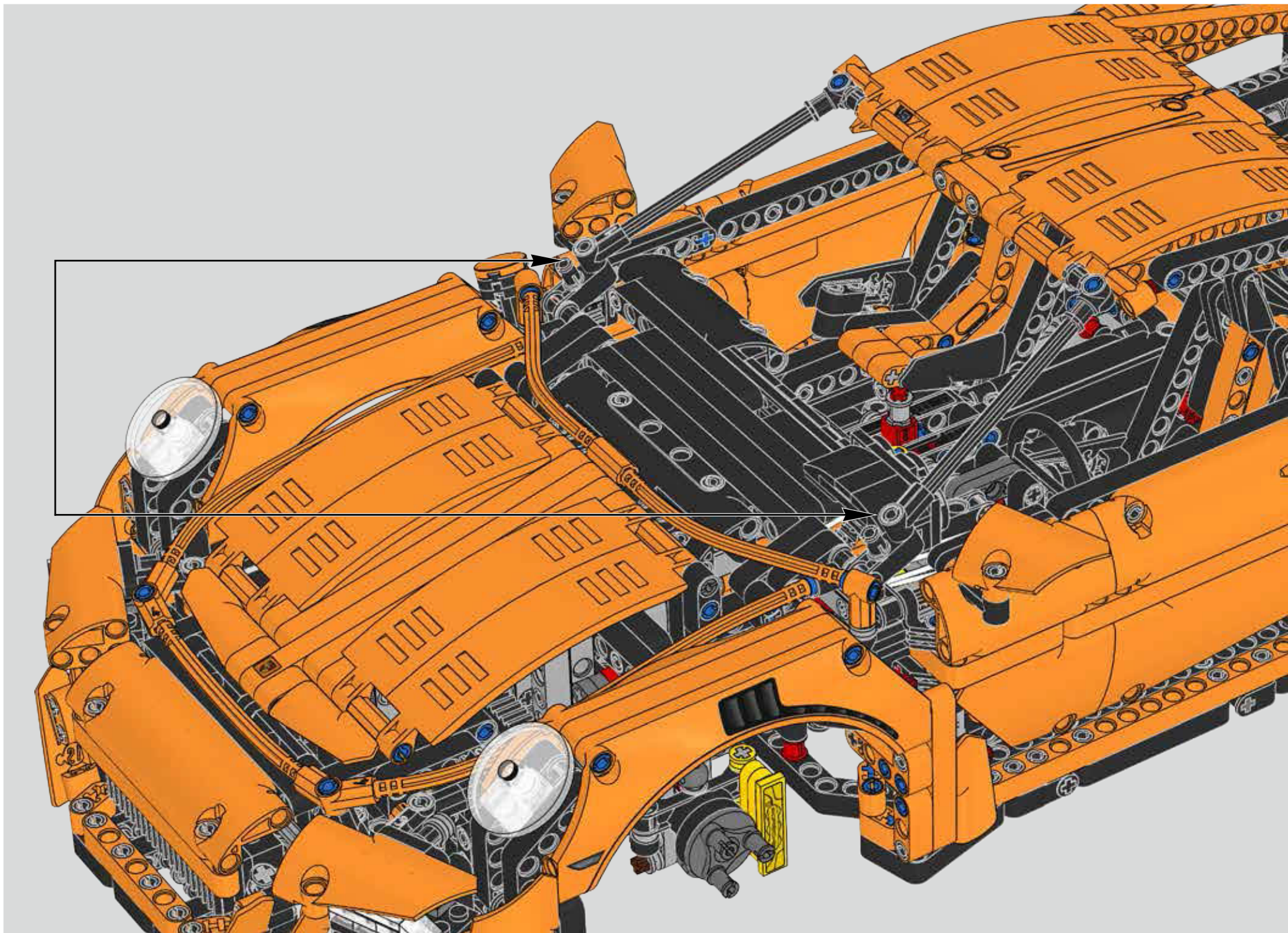

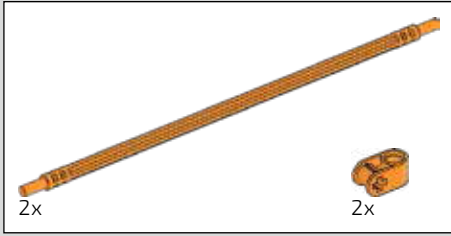

840

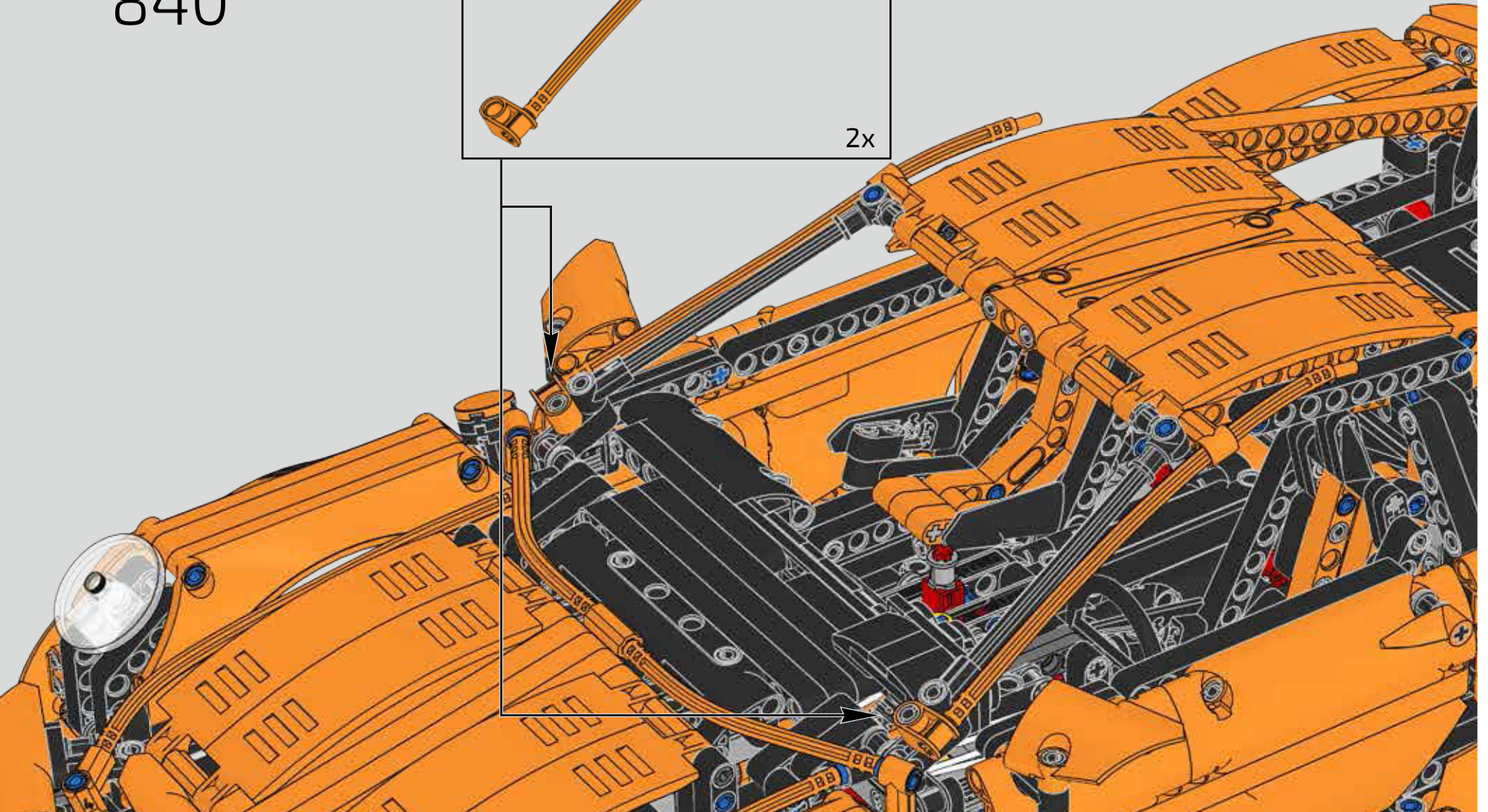
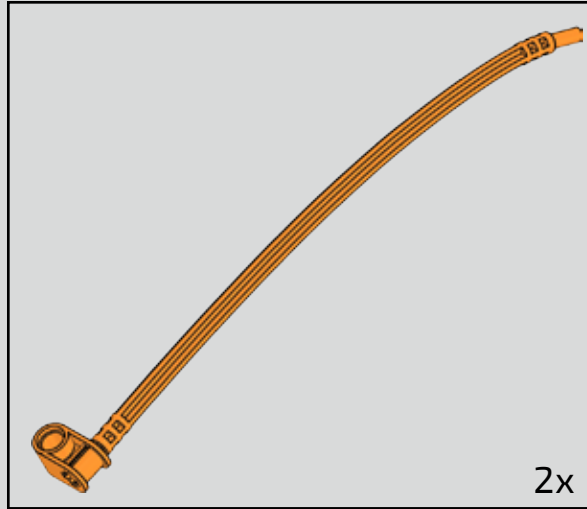

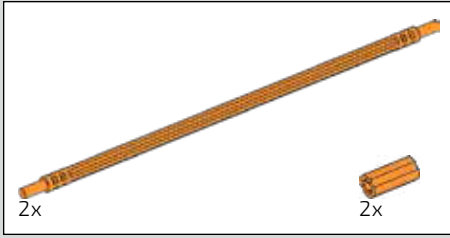

841

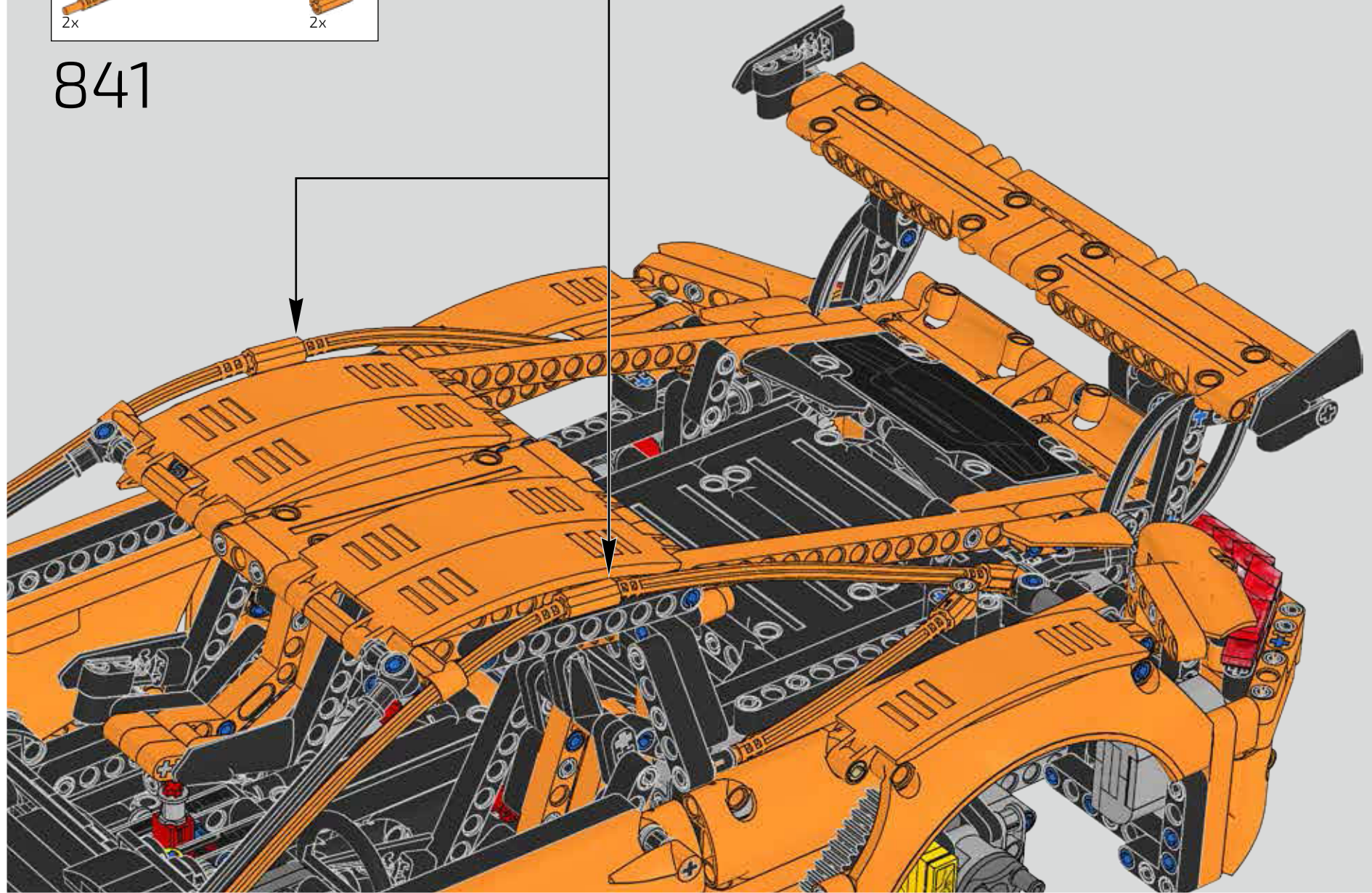

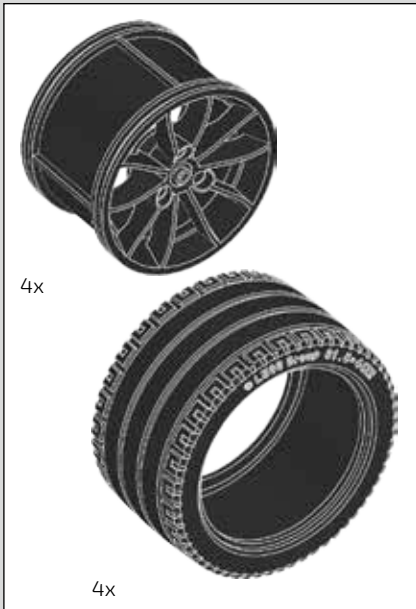

842

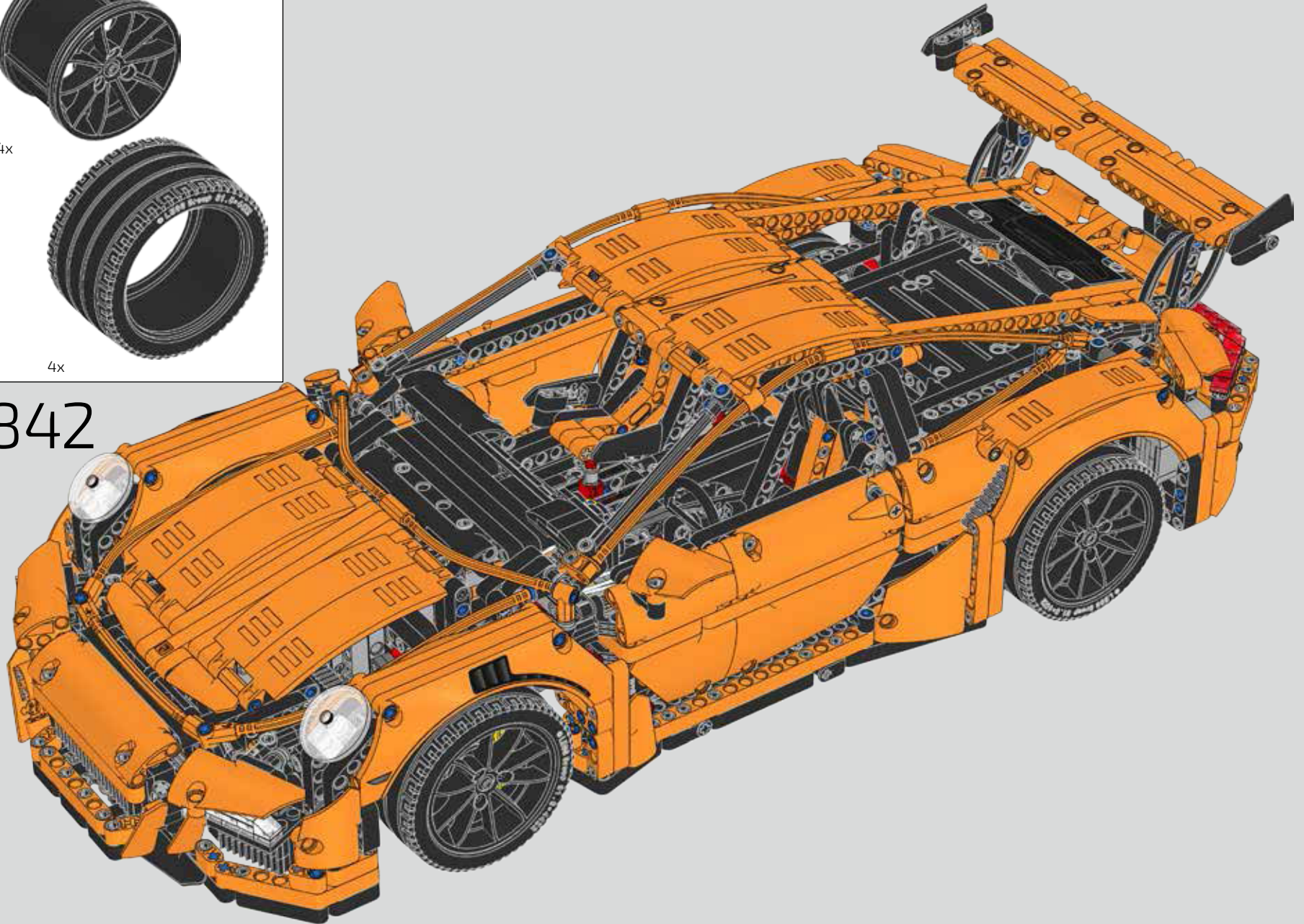

4x

843

2x

2x

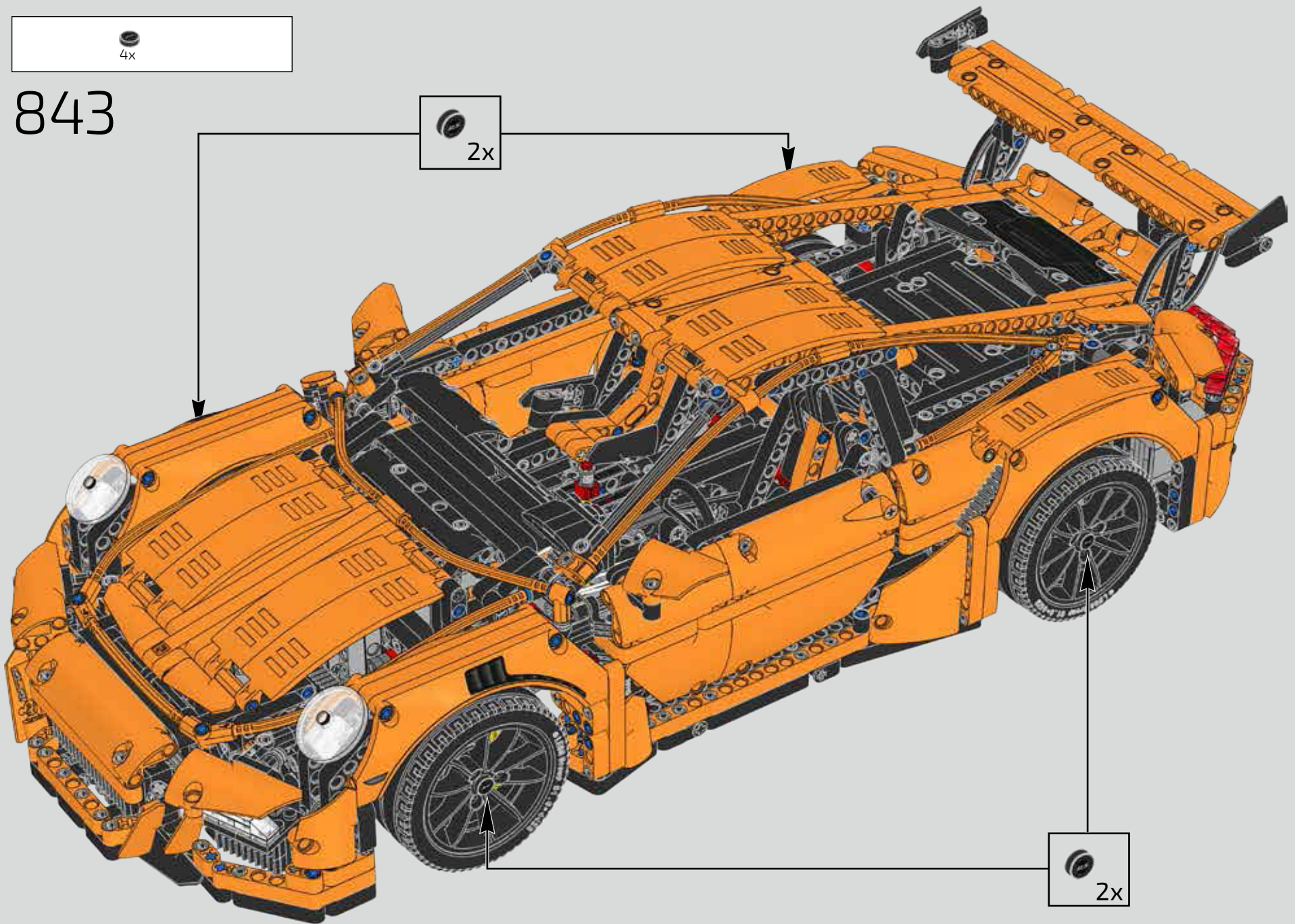

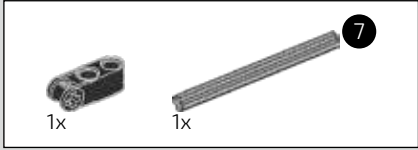
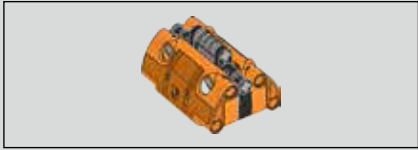

844

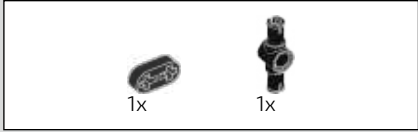
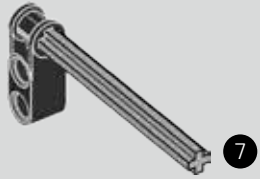

845

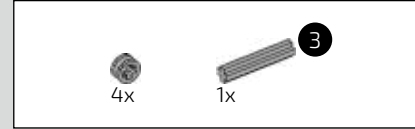
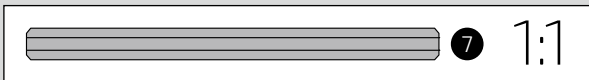
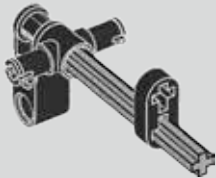

846

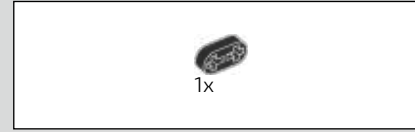
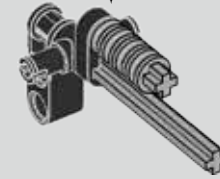
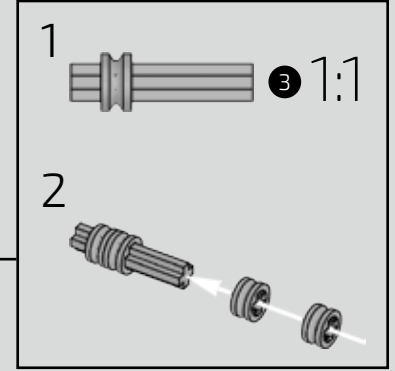

847

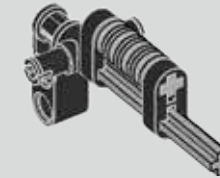



848

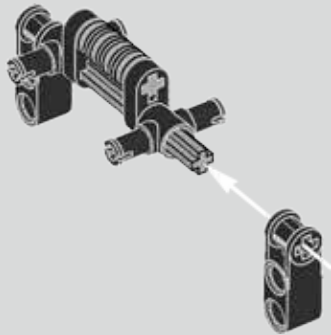

849

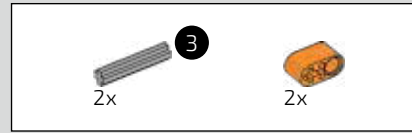
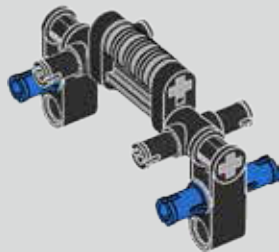

850

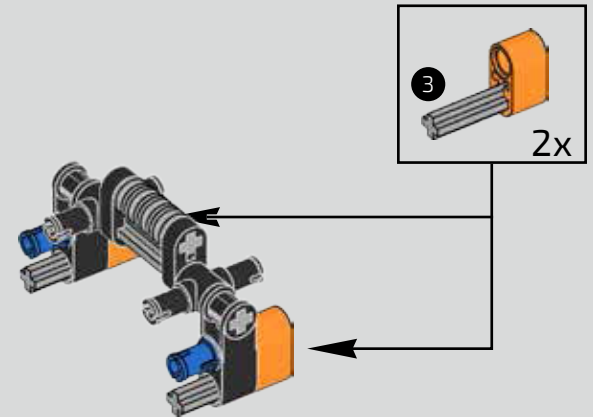

851

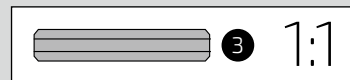
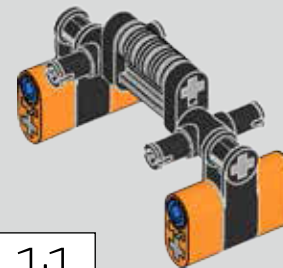

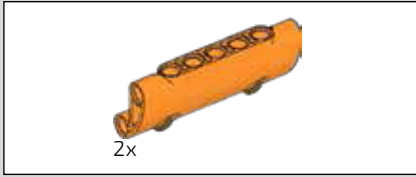

852

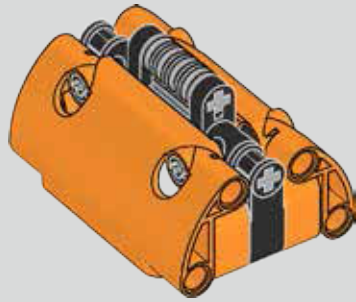

853

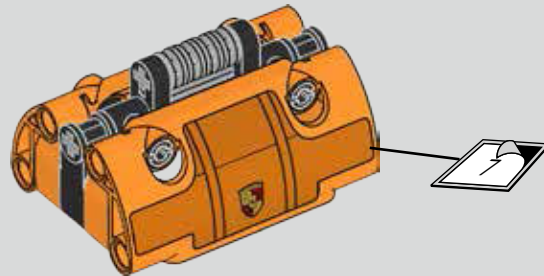
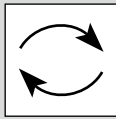

854

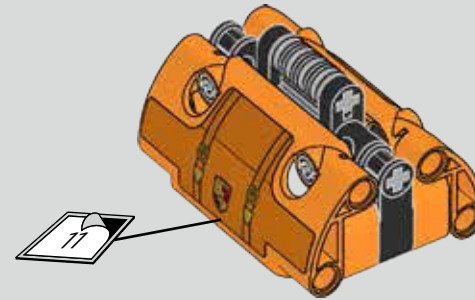
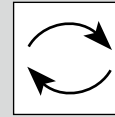

855

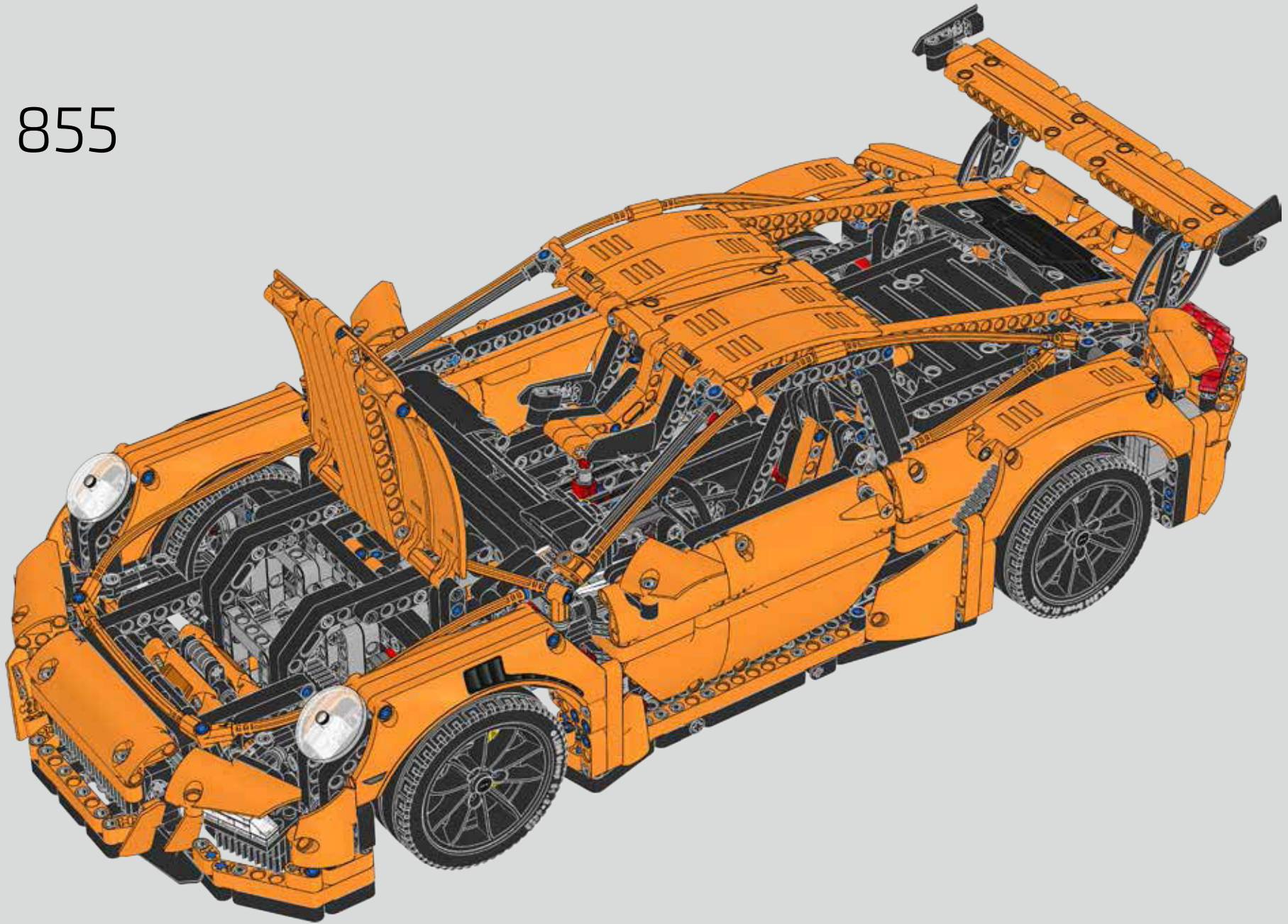

856

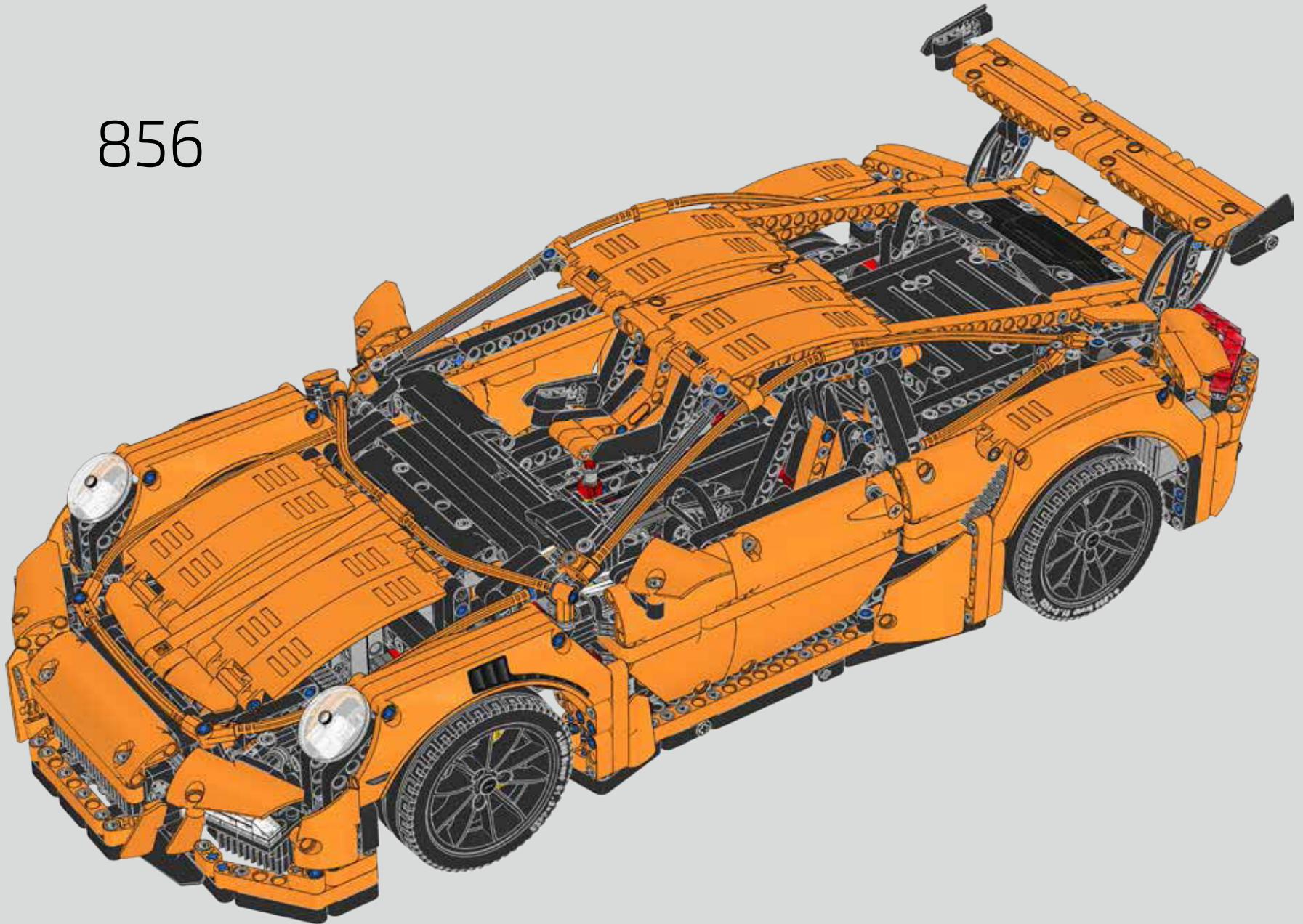

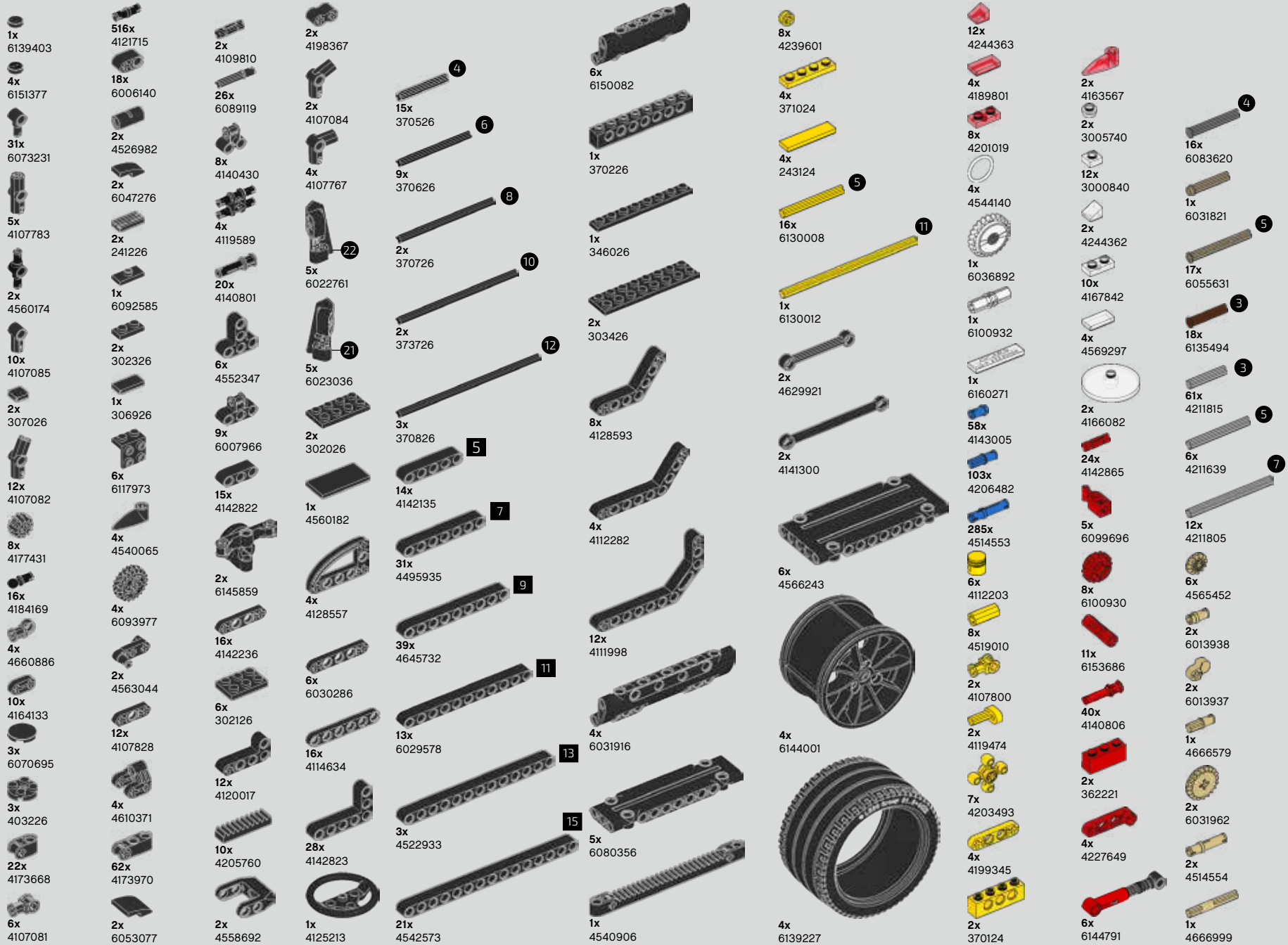

1x 6092770
 8x 6135088
 15x 6143028
 51x 6057526
 4x 4538144
 2x 4281515
 21x 6135091
 2x 6074869
 2x 4650690
 22x 6102618
 14x 6102621
 10x 6135085
 10x 4629802
 10x 6135083

2x 4657639
 4x 6097284
 4x 6093833
 5x 6022767
 4x 6132961
 2x 6103618
 2x 6103634
 2x 6143018
 2x 6143017
 1x 6135080
 1x 6135079

5x 6022768
 4x 6132960
 2x 6103634
 2x 6143017
 1x 6135079

2x 6004156
 8x 6149936
 4x 4580022
 3x 6102612
 10x 6135061
 4x 6146786
 1x 6151466
 1x 6151467
 5x 6142996
 7x 6126922

12x 6100030
 2x 6019987
 6x 4223767
 5x 4610374
 50x 6015356
 2x 6133119
 4x 4610378
 1x 4525184
 1x 4508553
 4x 6074651
 4x 4508664
 14x 6143015
 1x 4121741

5x 6012451
 3x 6100931
 4x 6083456
 6x 4234251
 8x 4211610
 8x 4211713
 2x 6055519
 2x 4211549
 2x 4211466

19x 4211621
 11x 4560175
 29x 4211622
 4x 4211375
 1x 4211637
 22x 4211775
 13x 4640536
 4x 4211889
 5x 4526985
 2x 4233493
 4x 4558690
 6x 6000018
 2x 6022949
 4x 6045988

26x 4211573
 7x 6122217
 12x 4211655
 6x 4225033
 4x 4211561
 3x 4211356
 2x 4211394
 16x 6029206
 2x 6009019
 4x 4211395
 6x 4260409
 2x 4560183

2x 4211651
 8x 4495930
 4x 6102449
 8x 4611705
 16x 4522934
 17x 4539880
 1x 4540797
 2x 4621555

Customer Service
 Kundenservice
 Service Consommateurs
 Servicio Al Consumidor
 LEGO.com/service or dial
 : 00800 5346 5555
 : 1-800-422-5346





Do you like the set?

The LEGO Group would like your opinion on the new product you have just purchased. Your feedback will help shape the future development of this LEGO set. Please visit LEGO.com/productfeedback

By completing our short feedback survey, you will be automatically entered into a draw to win a LEGO prize. Terms and conditions apply.

Aimez-vous cet ensemble ?

Le Groupe LEGO aimerait connaître votre opinion sur le produit que vous venez d'acheter. Vos commentaires nous aideront à améliorer le développement de cet ensemble LEGO. Merci de visiter LEGO.com/productfeedback

En remplissant ce court sondage sur le produit, vous serez automatiquement inscrit à un tirage au sort pour gagner un prix LEGO. Des conditions s'appliquent.

LEGO.com/productfeedback



Use your unique code on our website, LEGO.com/technic, to access a special gift!

Utilisez votre code unique sur notre site, LEGO.fr/technic, pour accéder à un cadeau spécial !





Porsche Museum, Stuttgart.
Musée Porsche, Stuttgart



Ensin
SPO



Porsche Museum, Stuttgart.
Musée Porsche, Stuttgart



LEMAUS' PORSCH E 27-025

1-2-3 LEMANS 82 27-026 ENDMIX

1-2-3 LEMANS 87 27-026 GESCHN

324 CARBERA GT/LEMAUS 80/ ENDMIX

324 CARBERA
UNWENDBAR

27-027

315

316

317

318

319

320

B15

IX DEUTSCH

HNITENES

IX DT./16.23

ARCEBA 6. / LETIANS 80
ORIGINAL + ENDPIX DEUTSCH

Formular with fields for 'Kategorie', 'Werkstoff', 'Lagerort', and 'Abt. Nr.' with a diagonal line through it.

Formular with fields for 'TE. WERKE', 'Kategorie', 'Werkstoff', 'Lagerort', and 'Abt. Nr.' with a diagonal line through it.

