

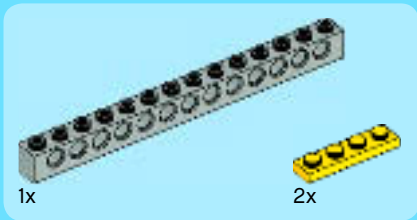

# CREATOR

5767





1

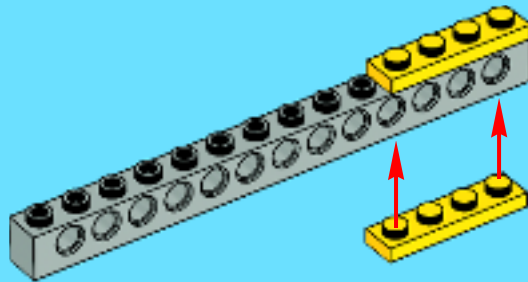

2

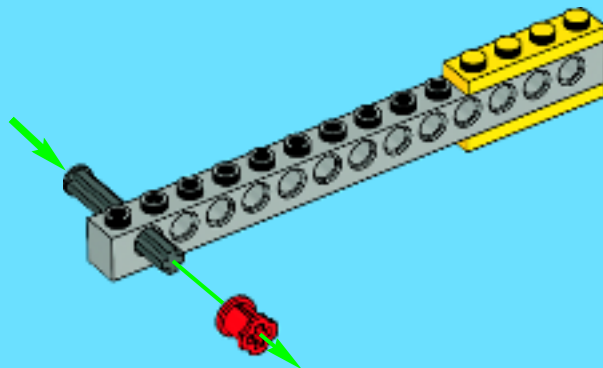



3

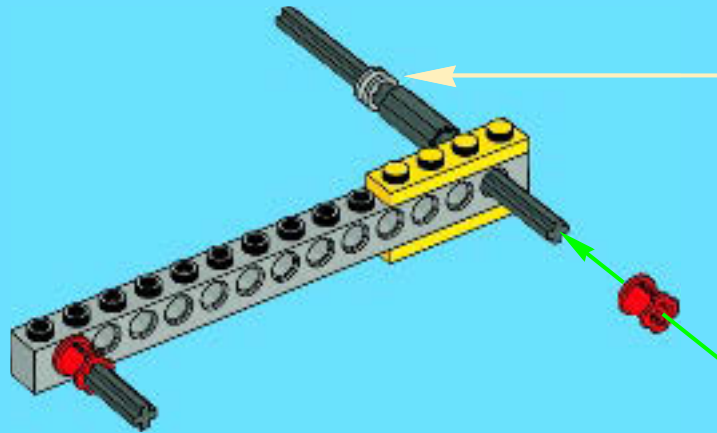
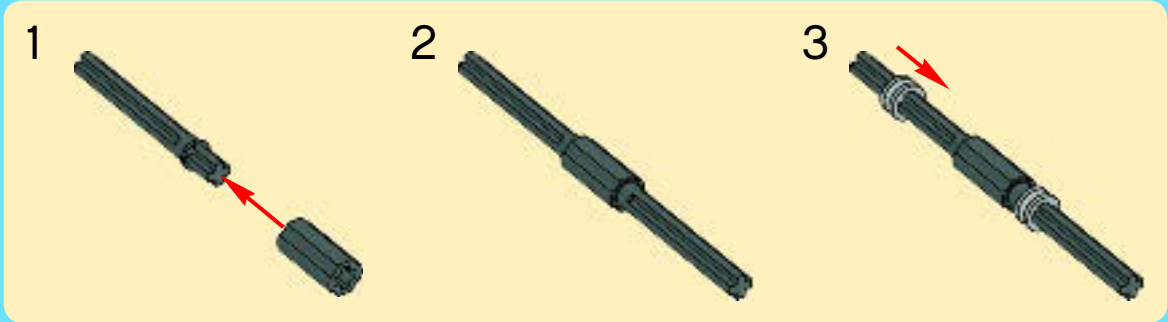

4

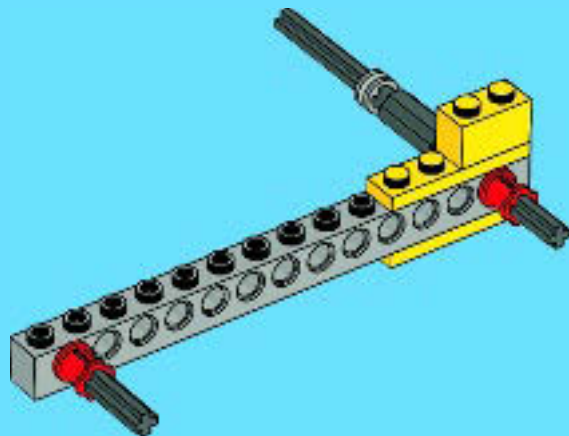



1

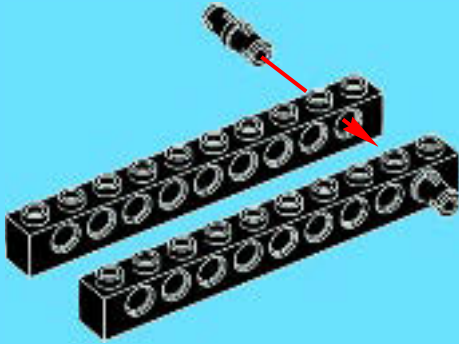

2

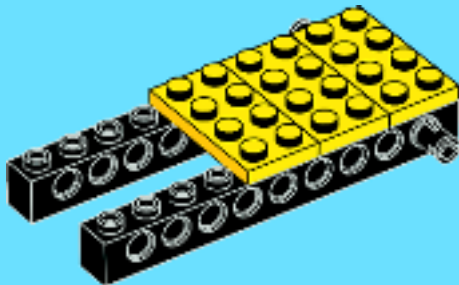

3

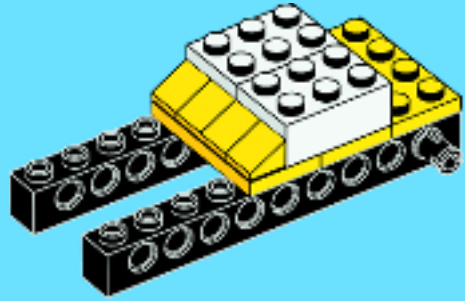

4

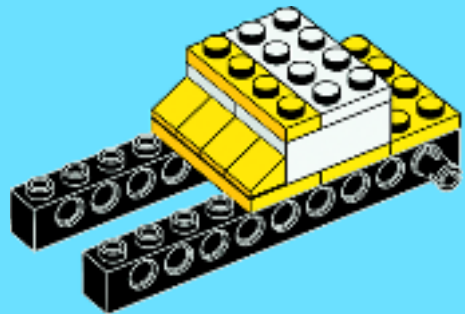



1x



1x

5

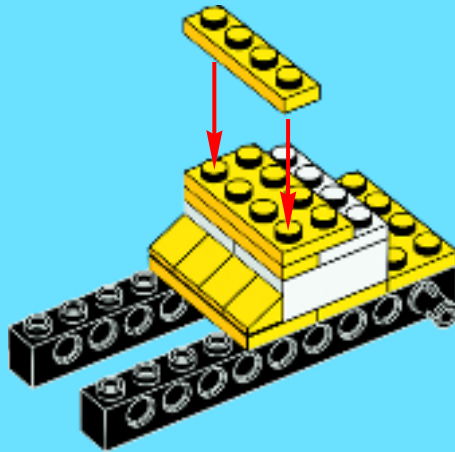

4x

6

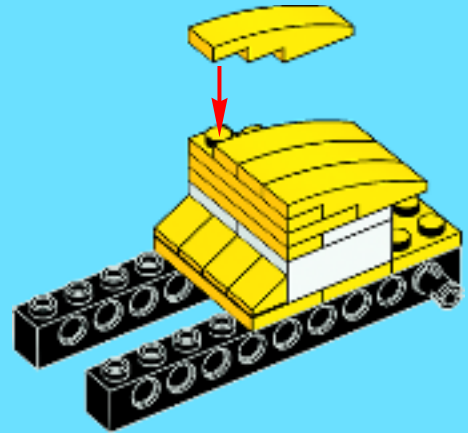

7

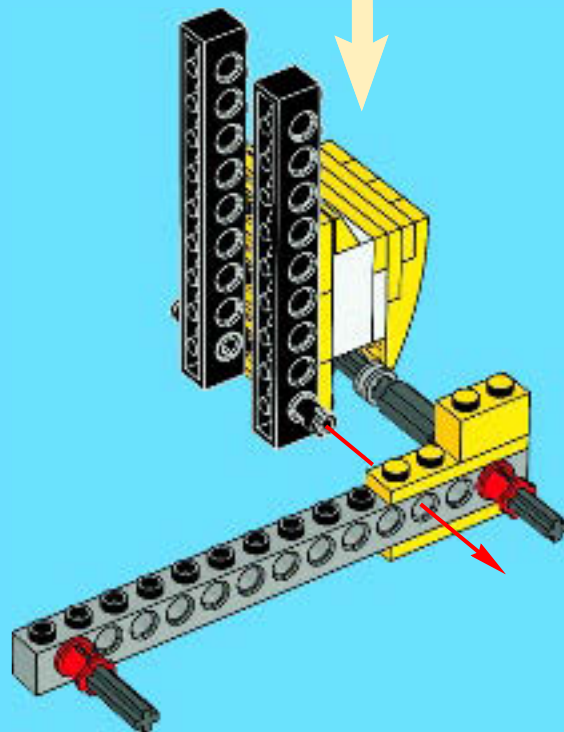

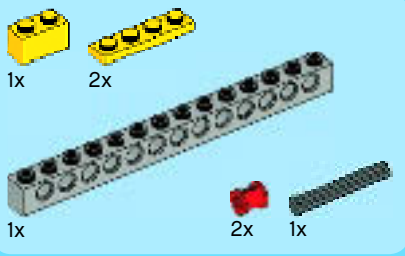

8

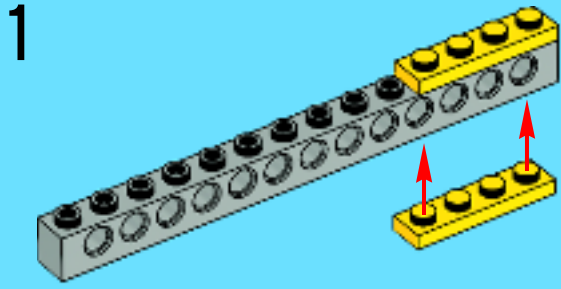

2

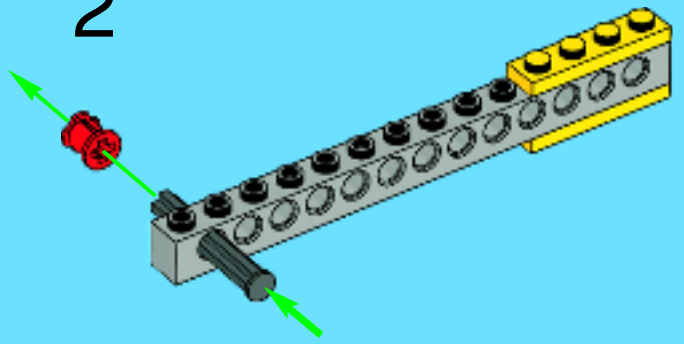

3

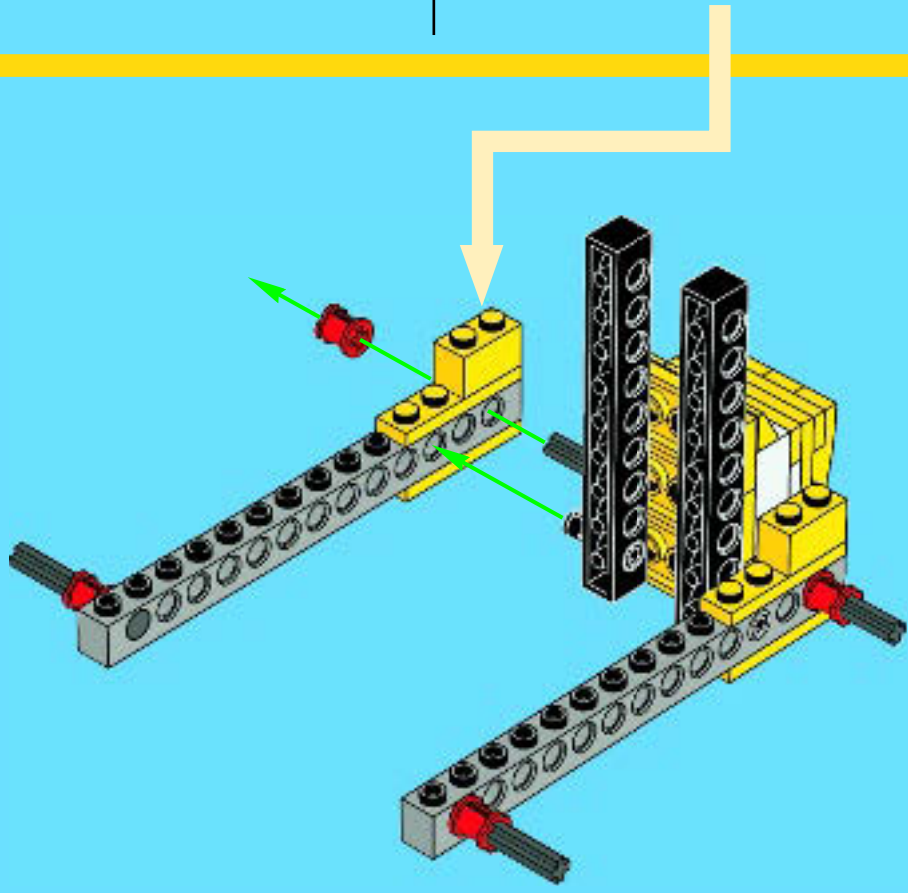
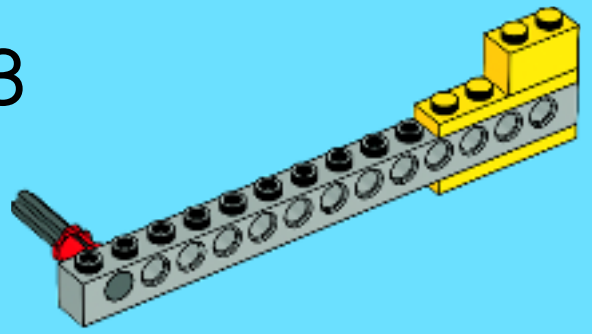



2x

# 9

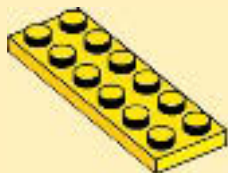

2x

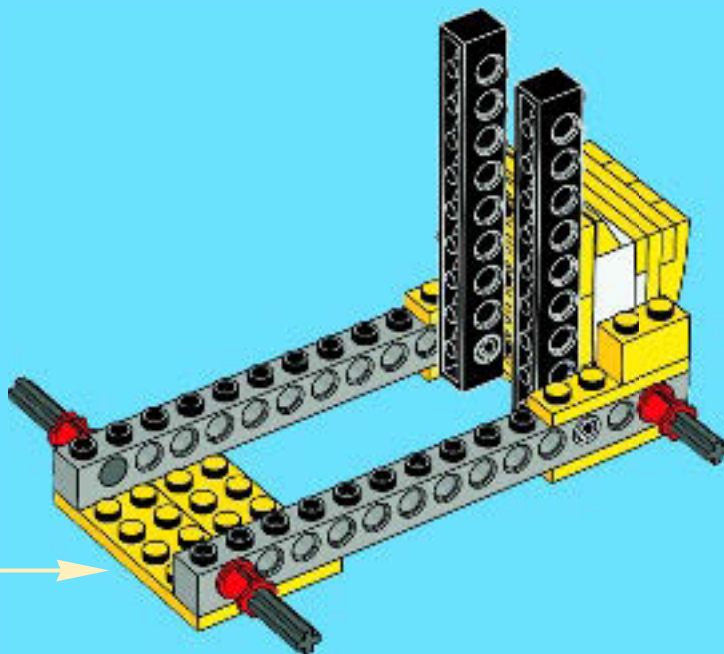

1x

# 10

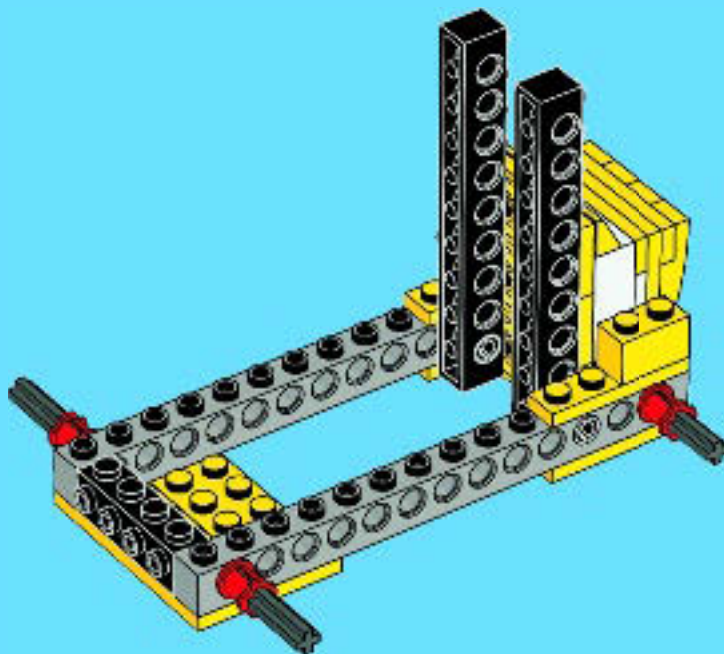



2x

6x



1x

# 11

1



2

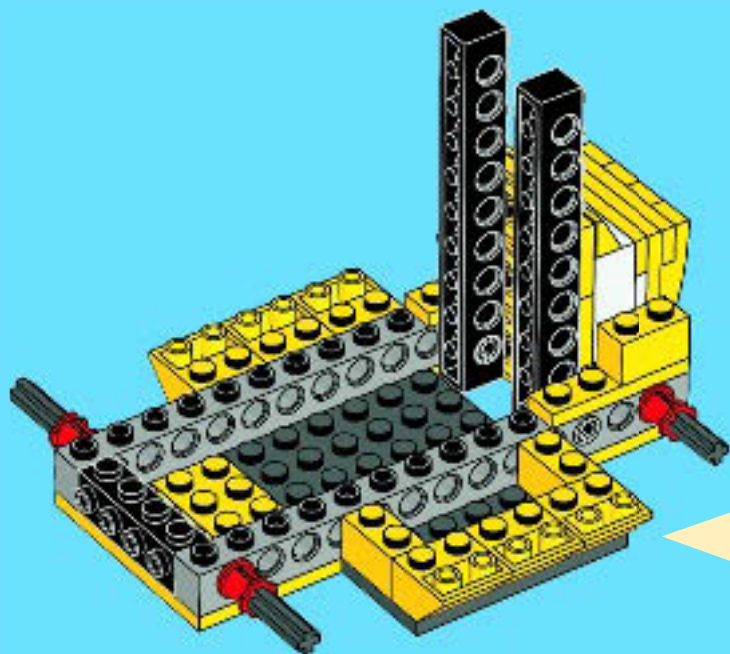
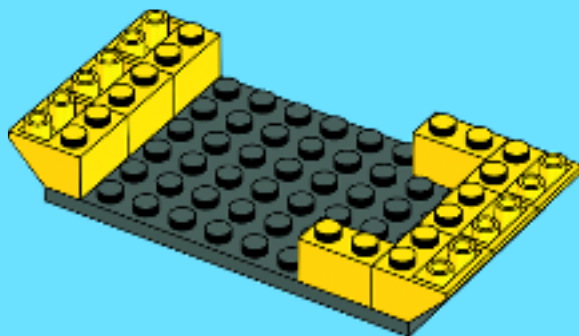



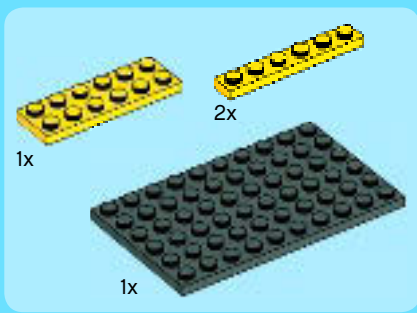

12

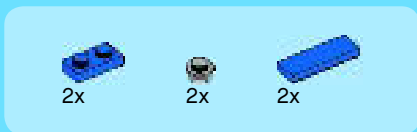
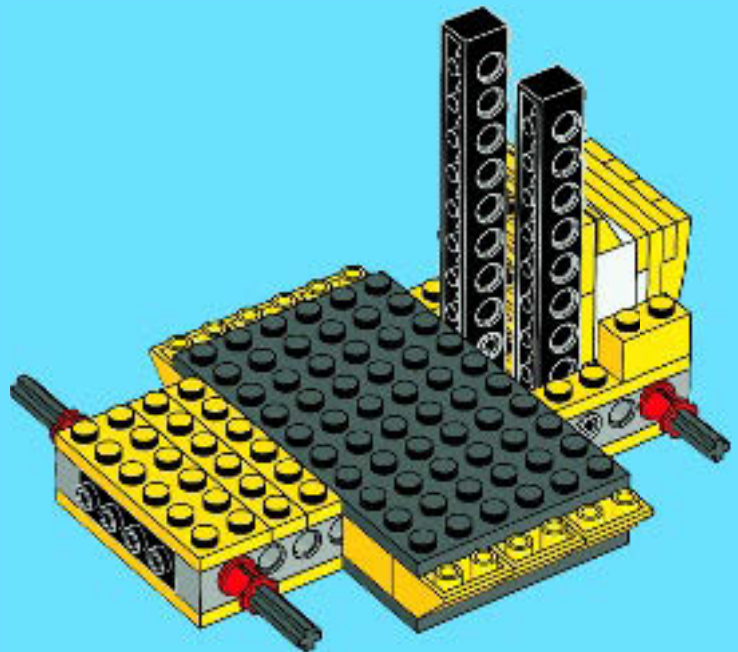

13

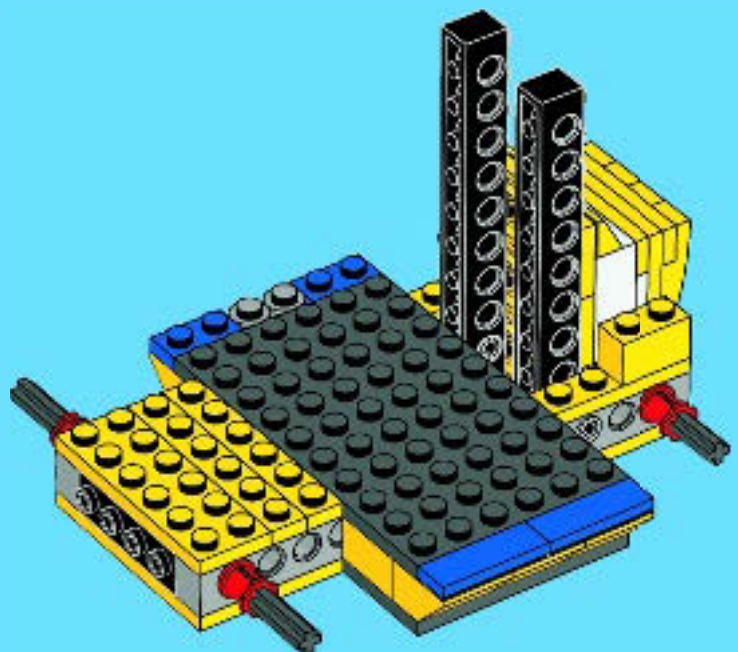



1x



1x



1x



2x



1x

# 14

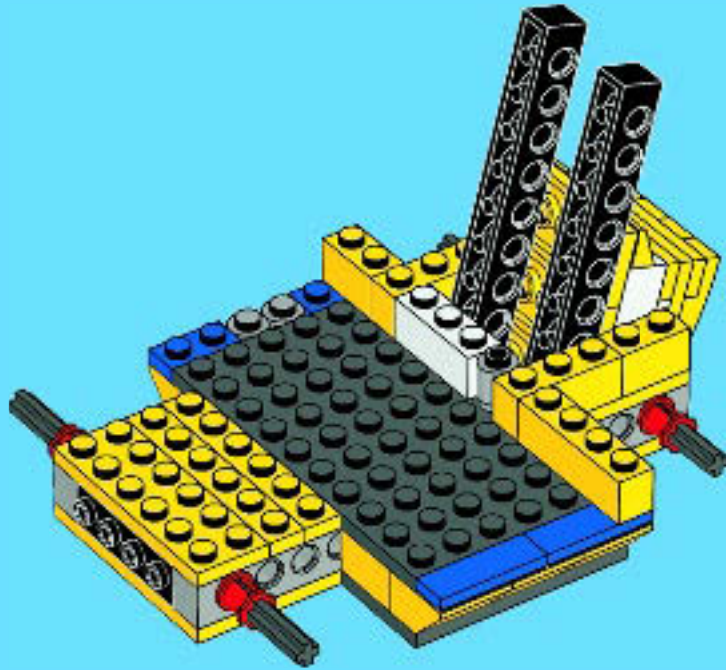

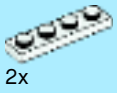

2x



2x



2x

# 15

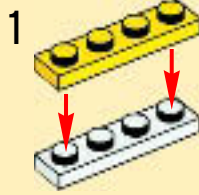

1

2

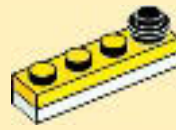

2x

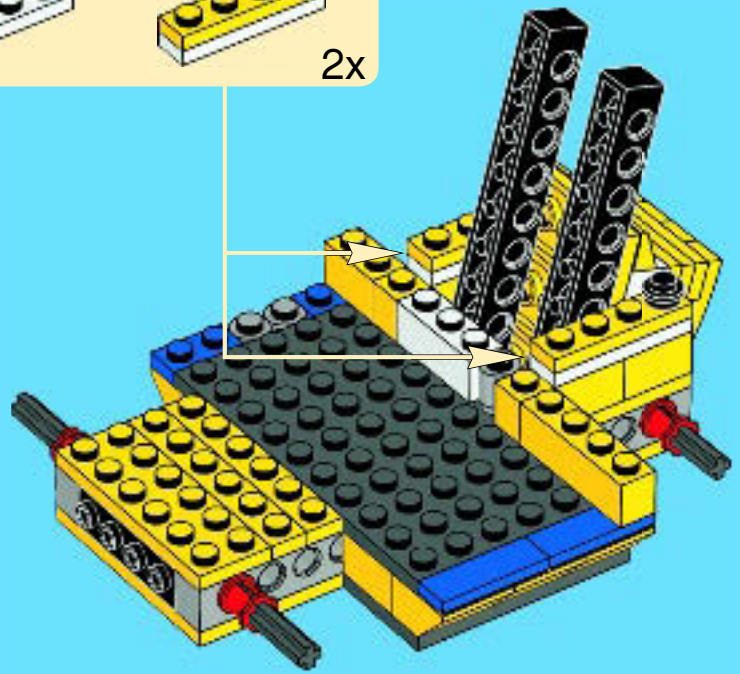

1x



1x



1x



4x

# 16

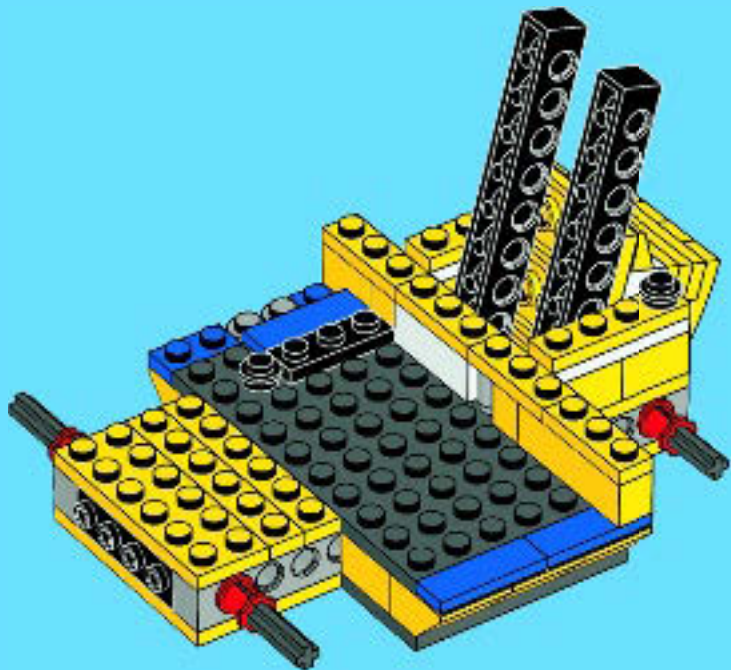

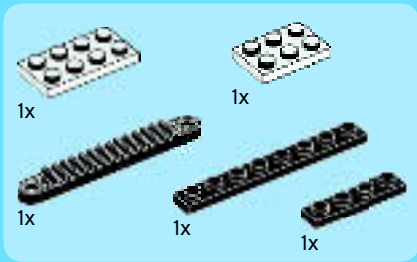

17

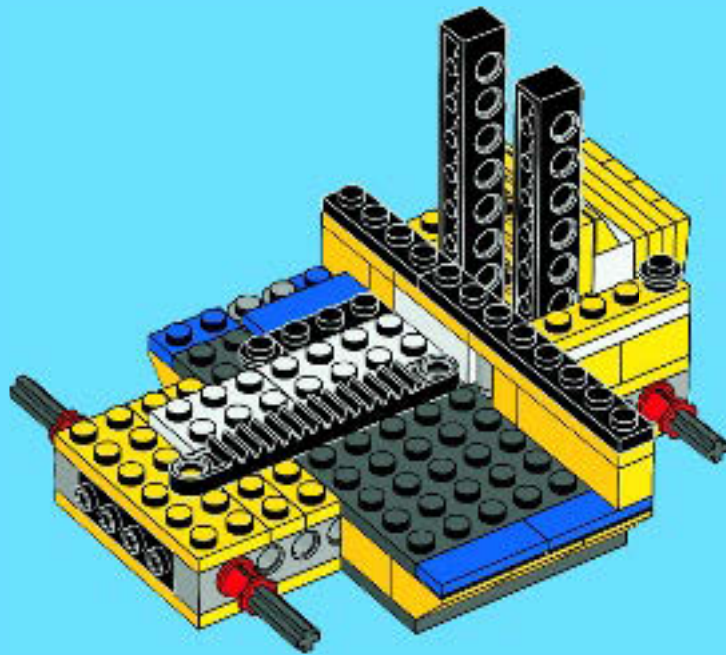



2x



1x



1x



1x

# 18

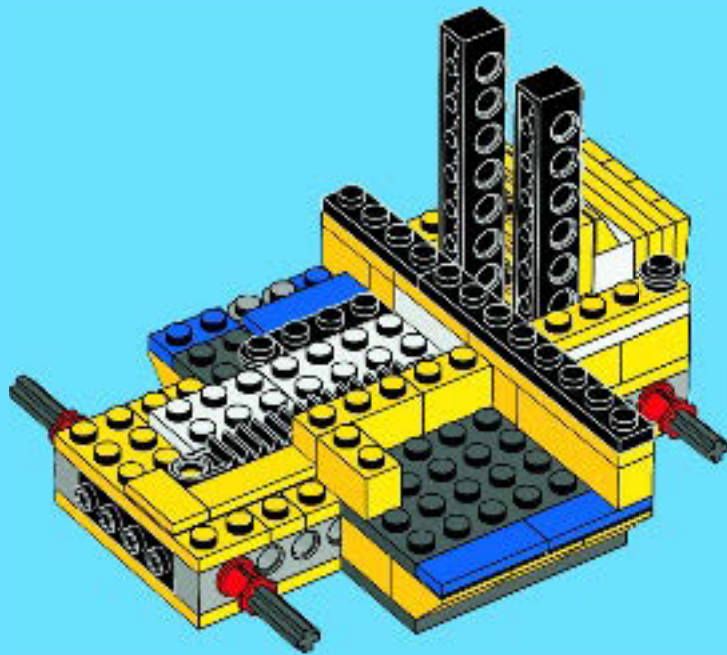



# 19

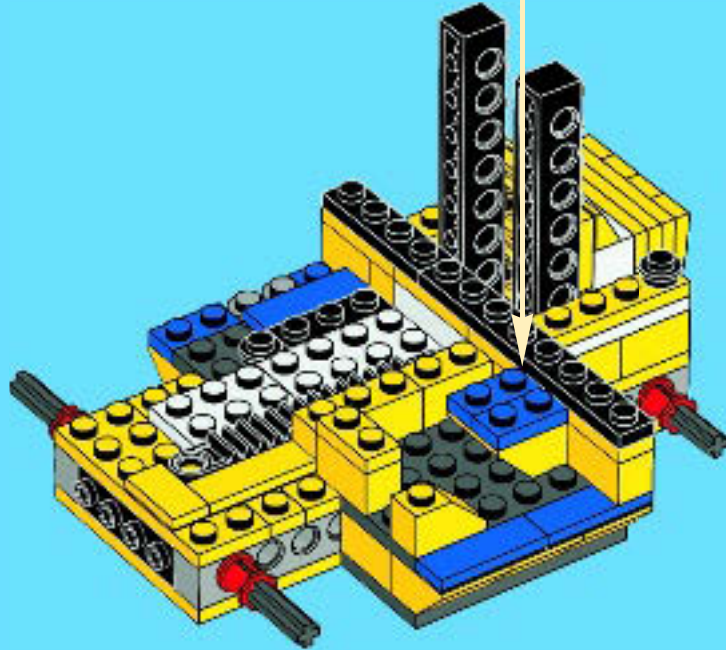



4x



1x



4x

# 20

1



2



3

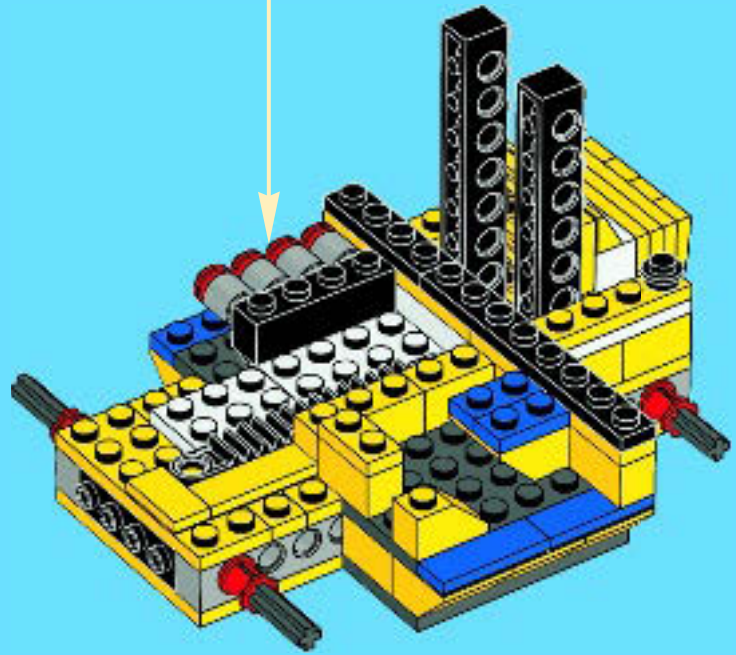



1x



2x

# 21

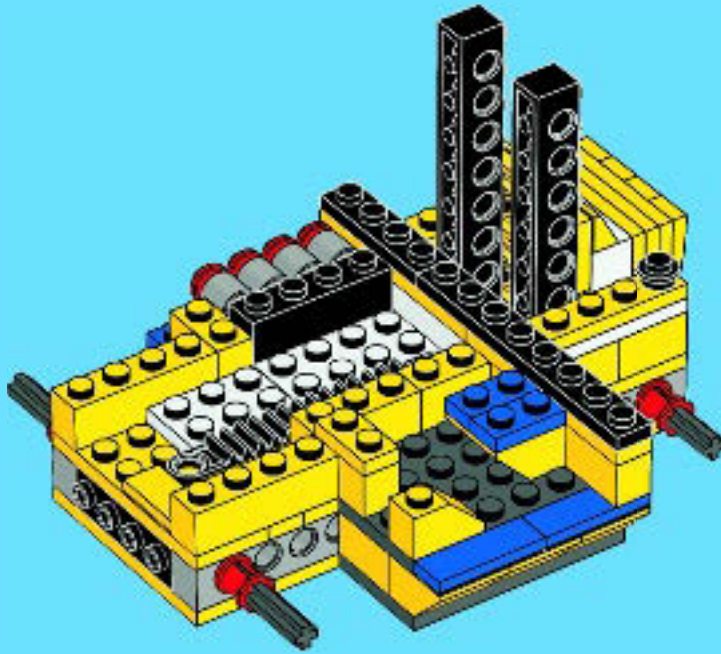

1x



2x

# 22

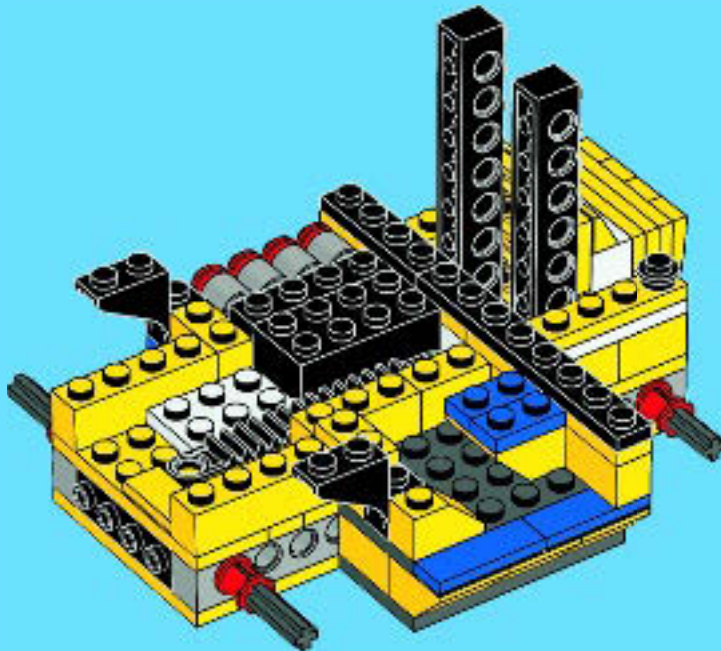





# 23

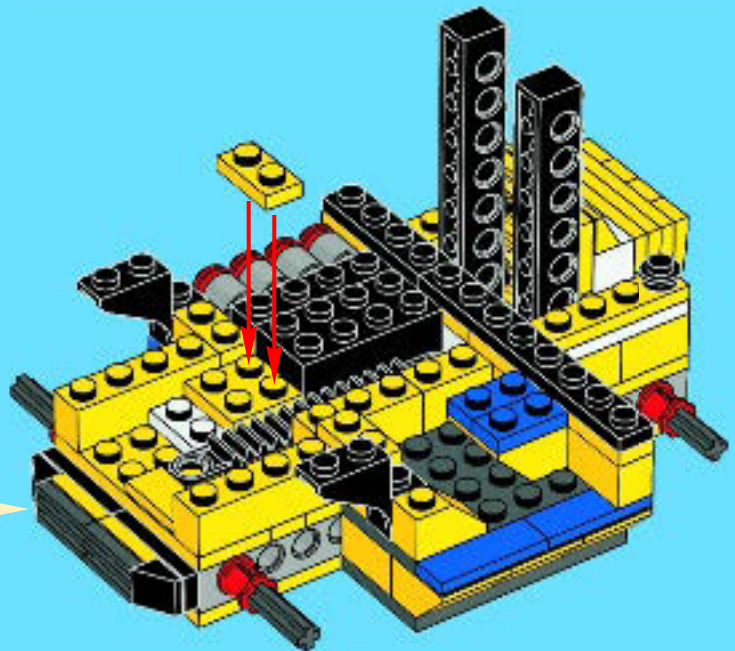
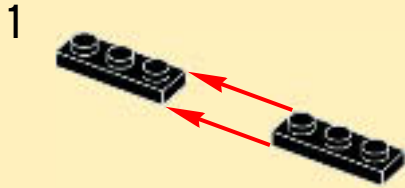



1x



1x



1x



2x

# 24

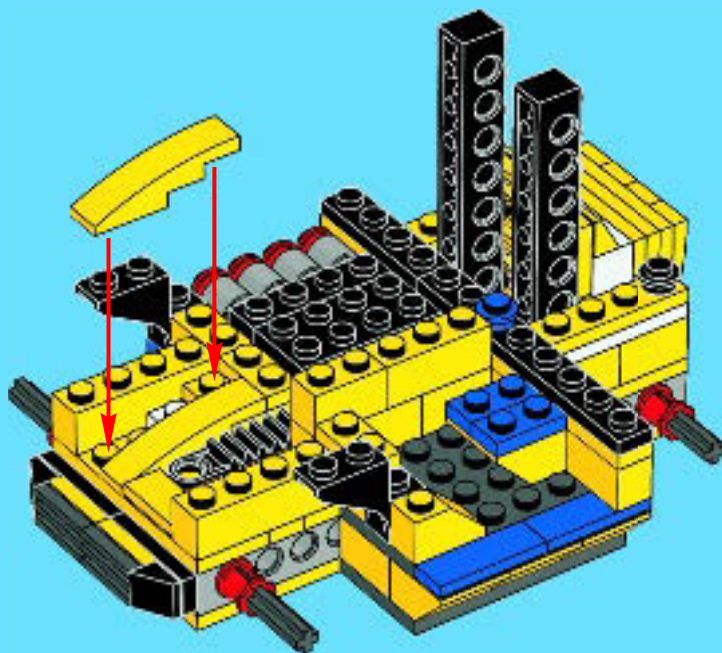



1x



1x



1x



1x

# 25

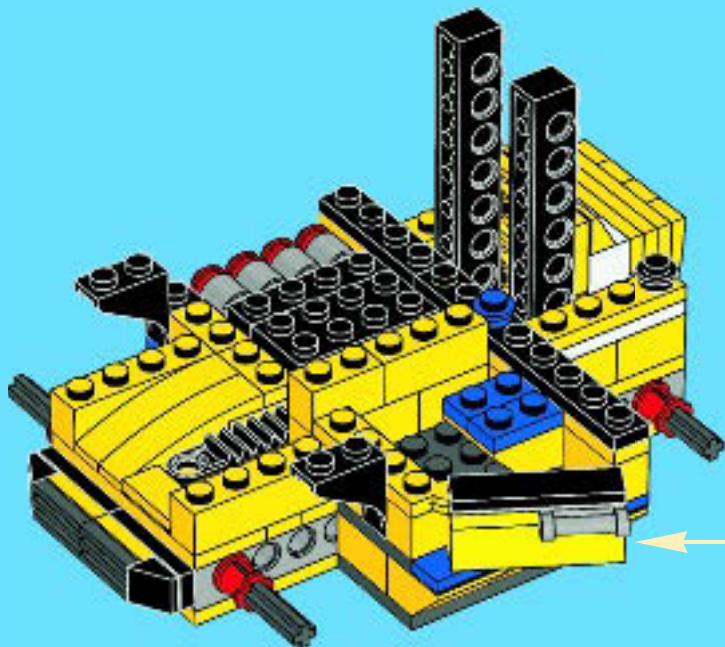

1

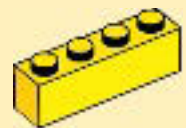

2

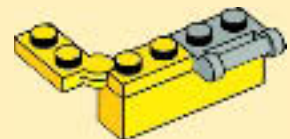

3

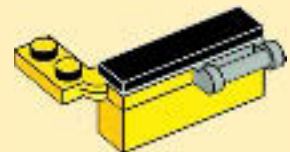



2x

# 26

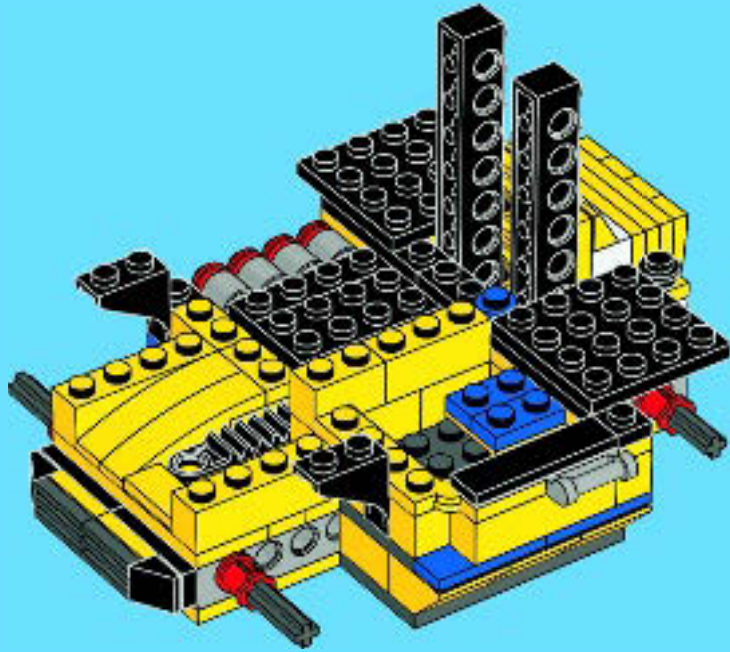

1x



1x



1x

# 27

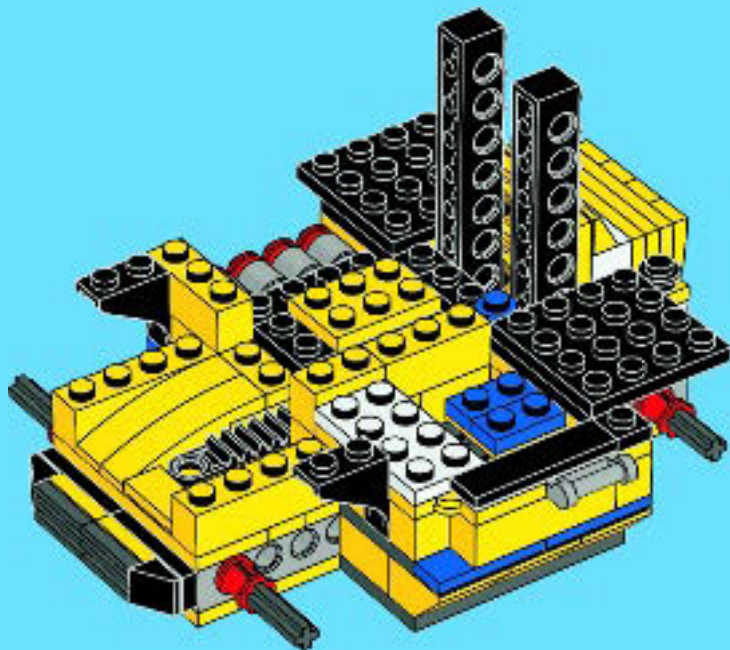



2x



2x



1x

# 28

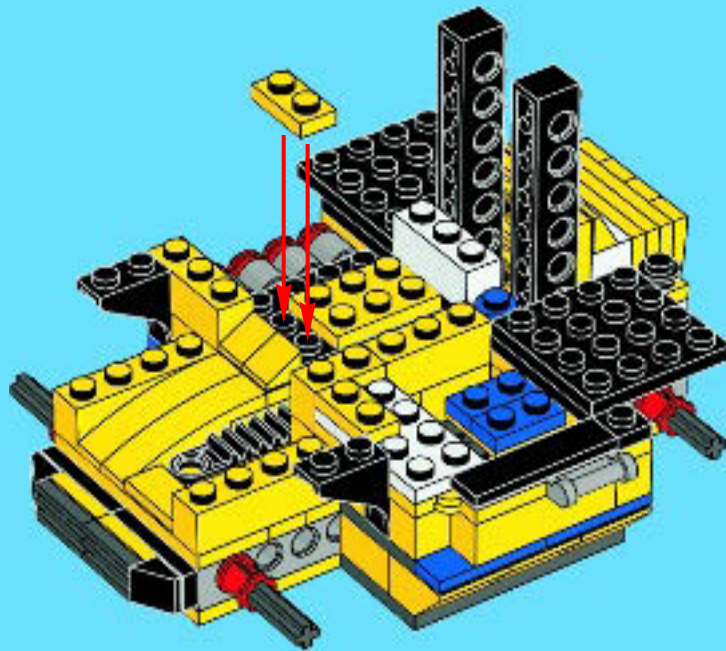



1x



4x



1x

# 29

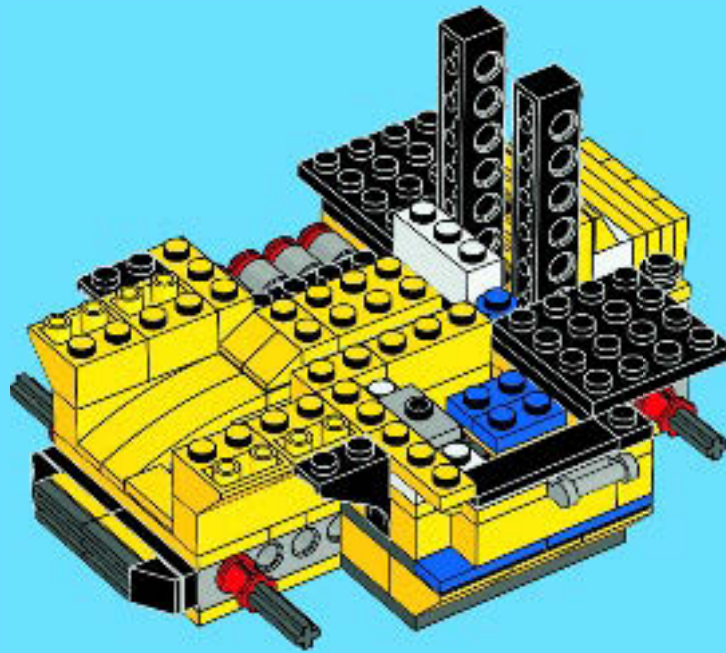



2x



2x

# 30

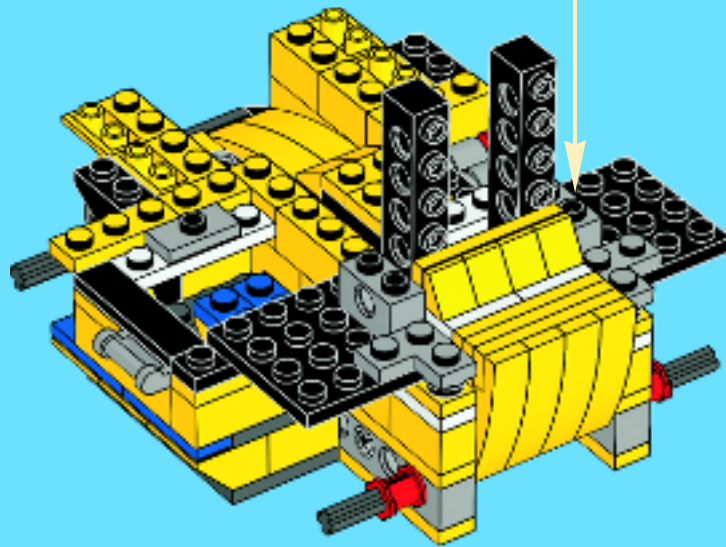



2x

# 31

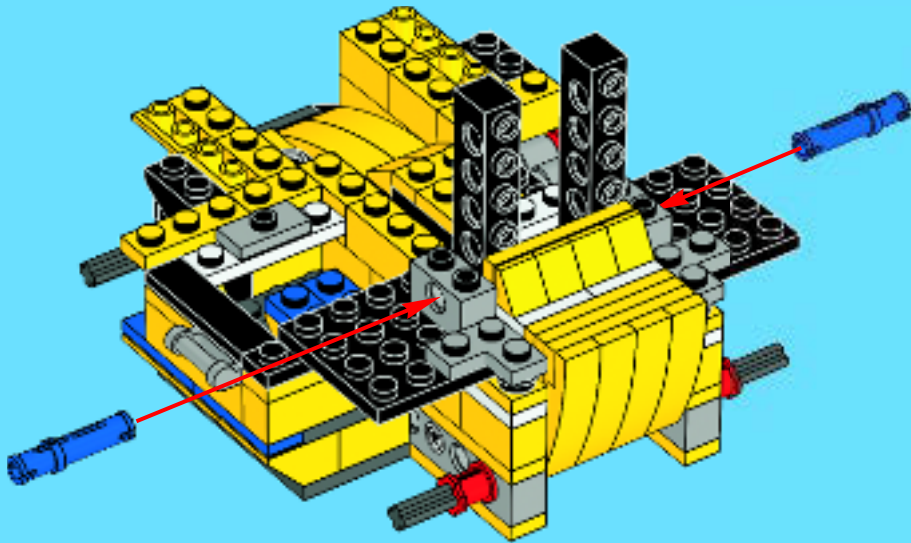





4x

# 32

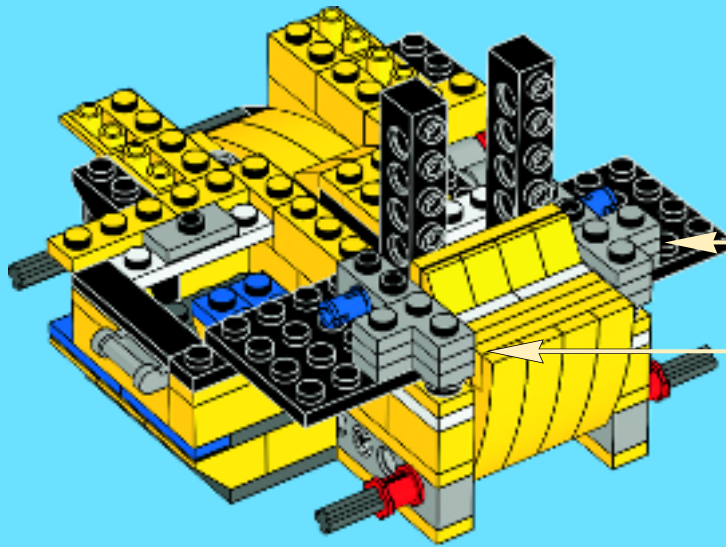
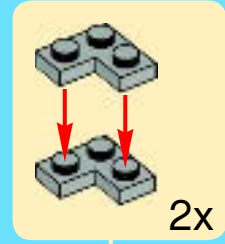



2x



2x

# 33

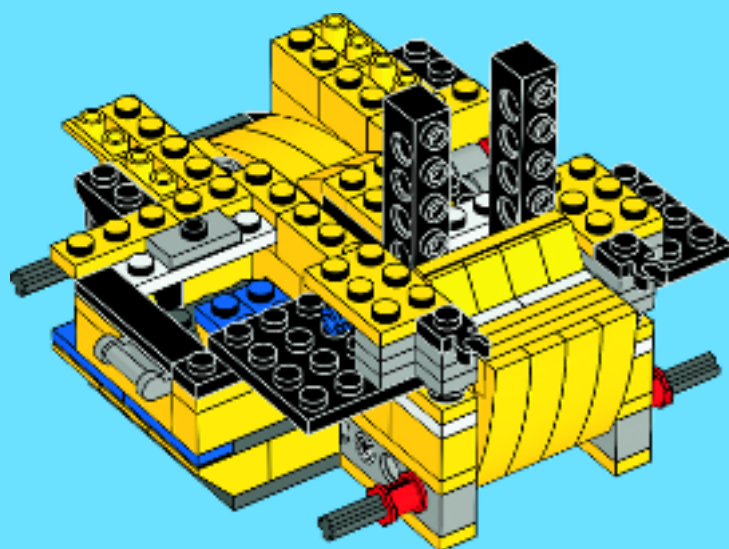



2x



2x



2x

# 34

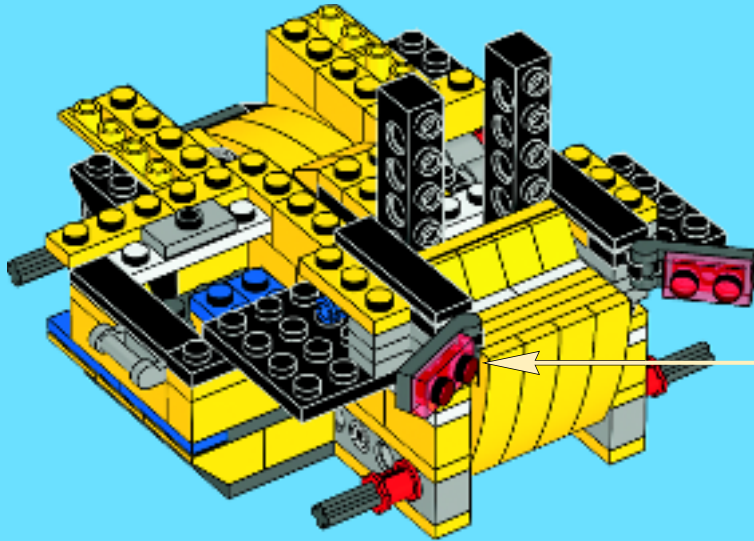
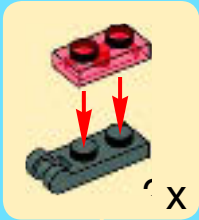



1x



1x



2x

# 35

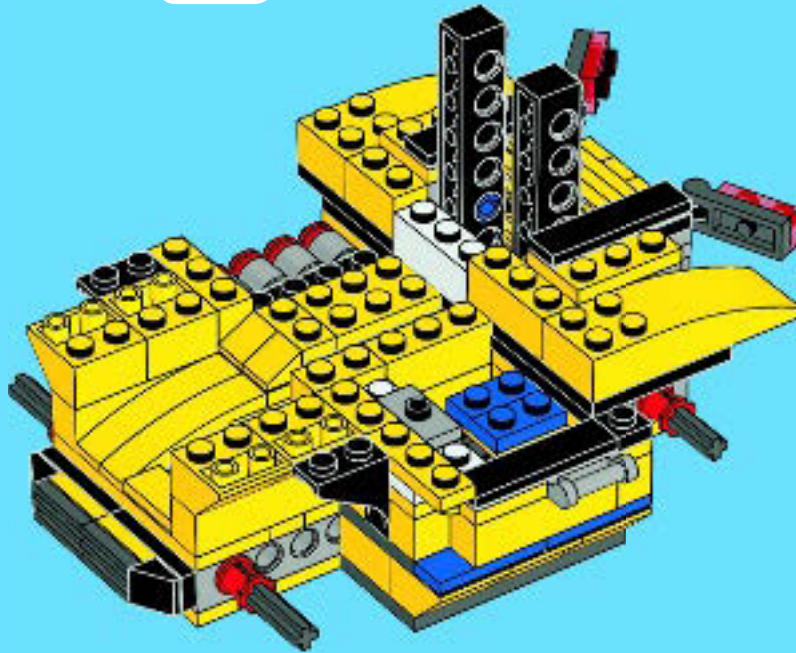



1x



1x



1x

# 36

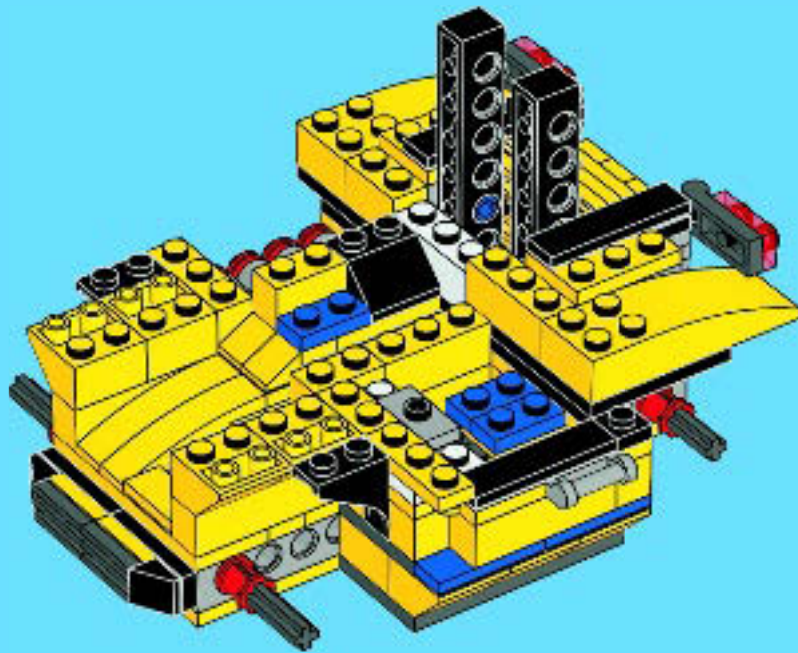



37

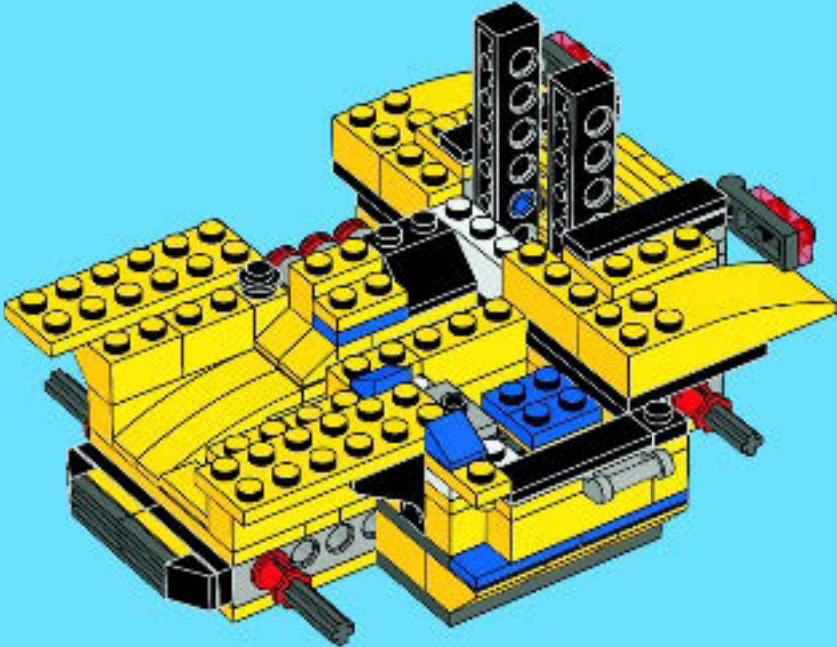



1x



1x



2x



4x

# 38

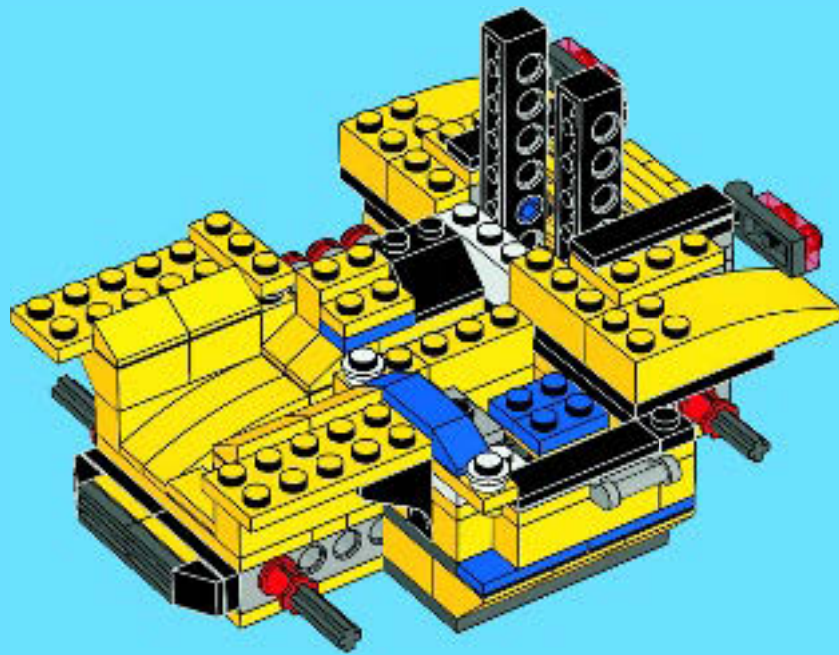



2x



1x



1x



1x

# 39

1



2

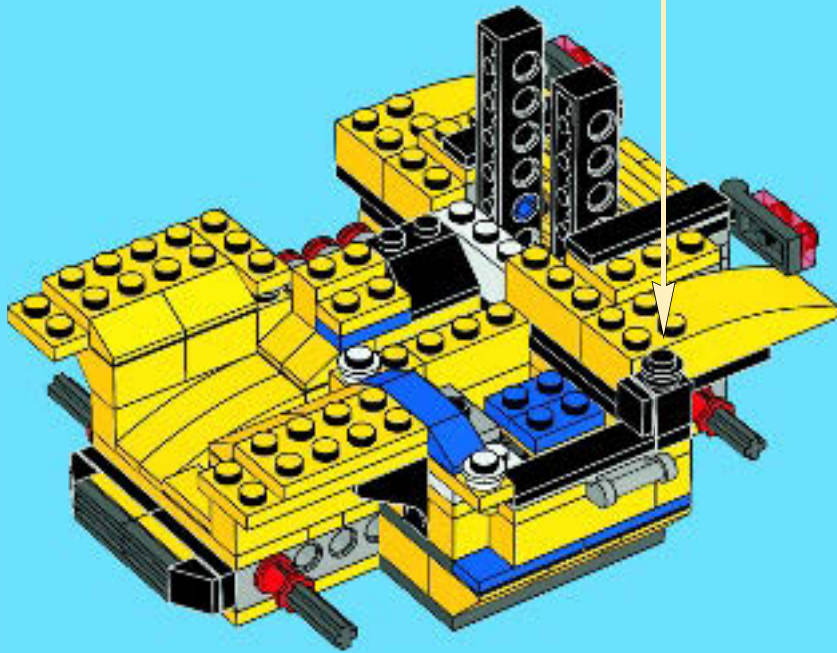





1x



2x



1x

# 40

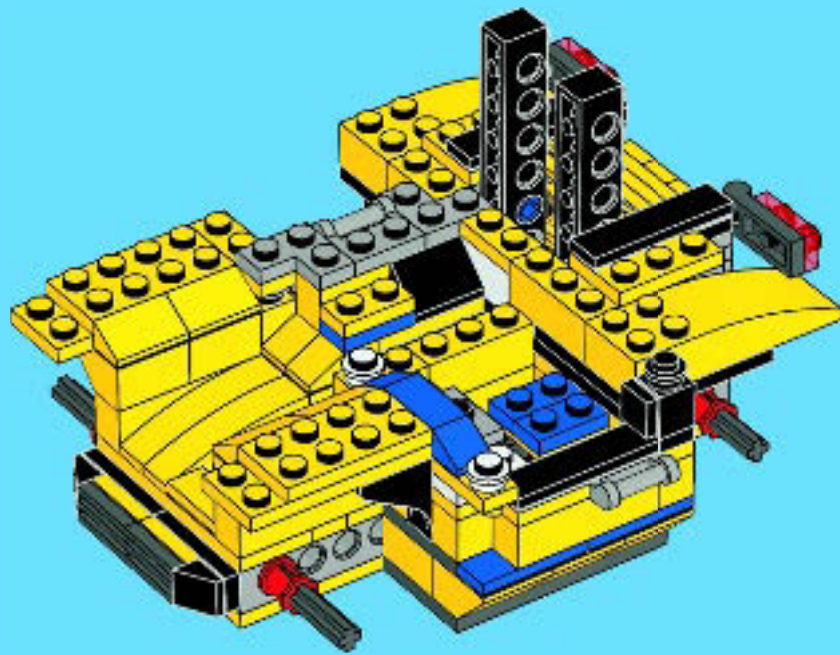



# 41

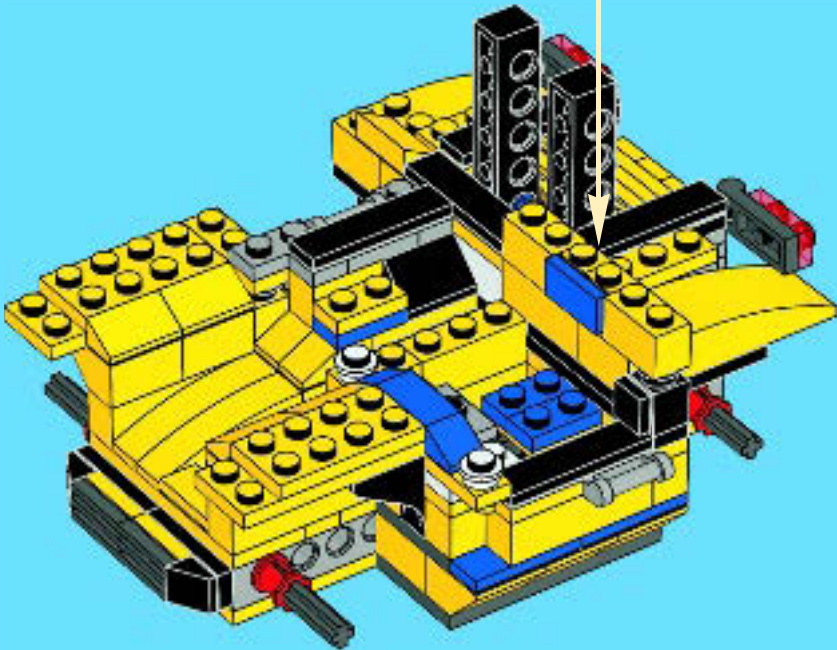
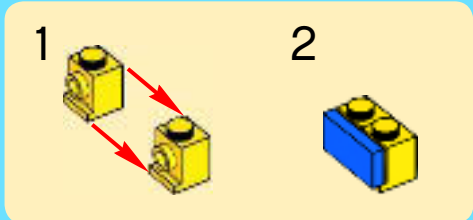



2x

1

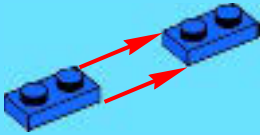

1x

2

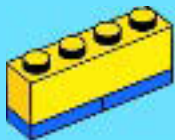

2x

3

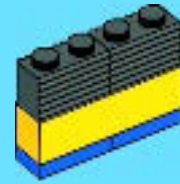

4x

4

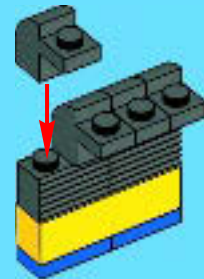

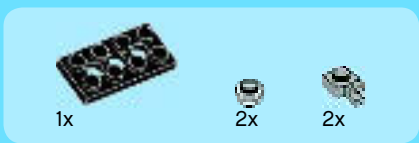

5

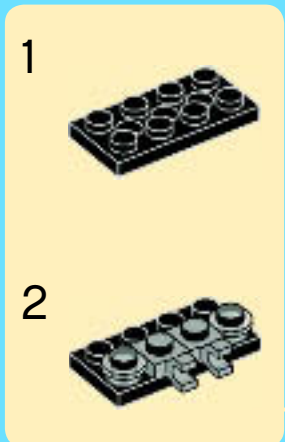

6

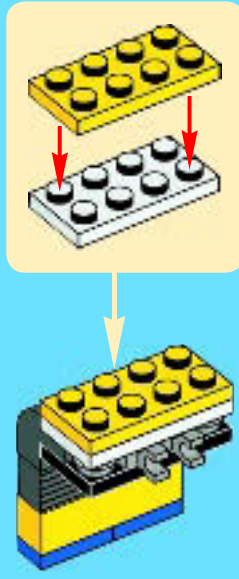

42

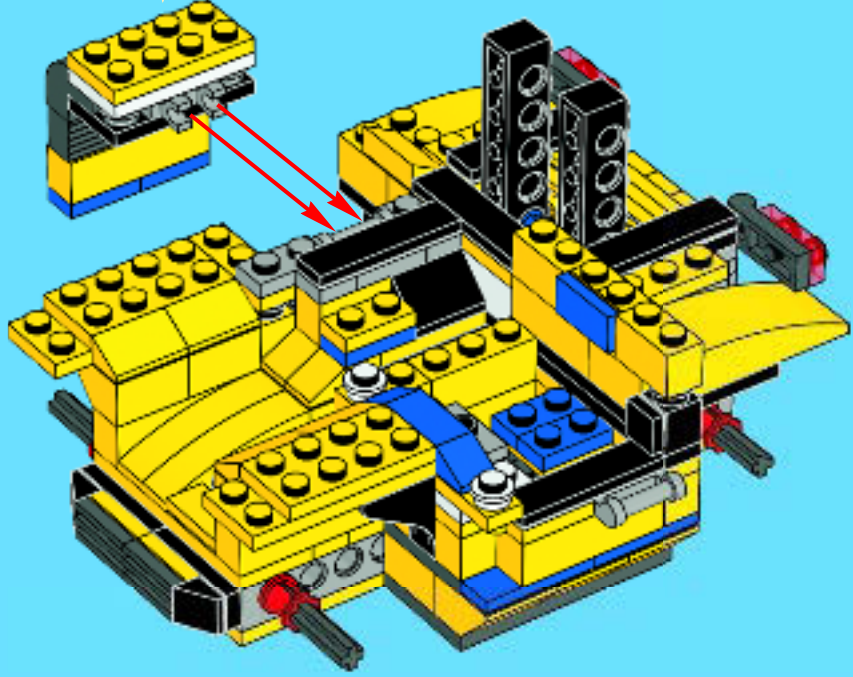



# 43

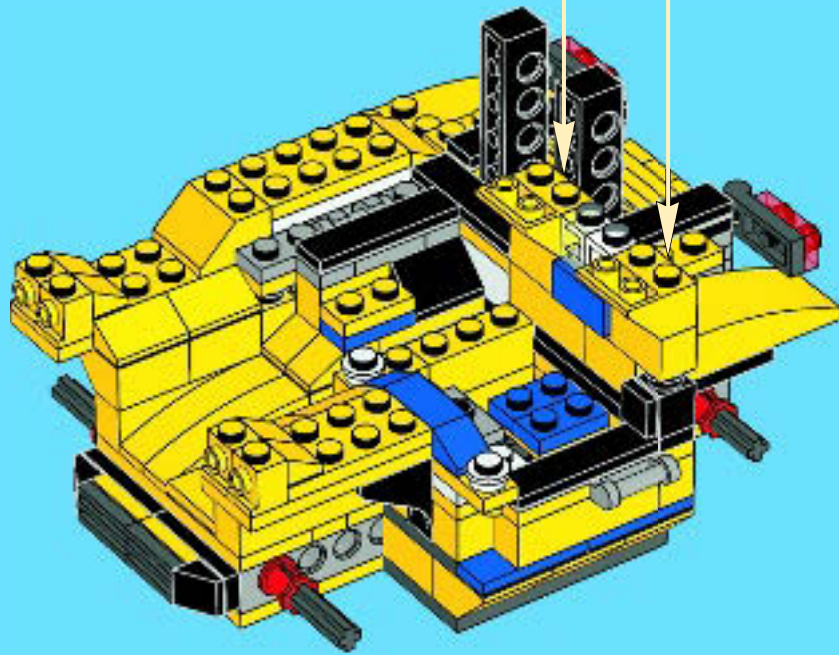
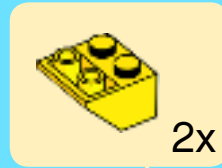



1x



2x



2x



1x

# 44

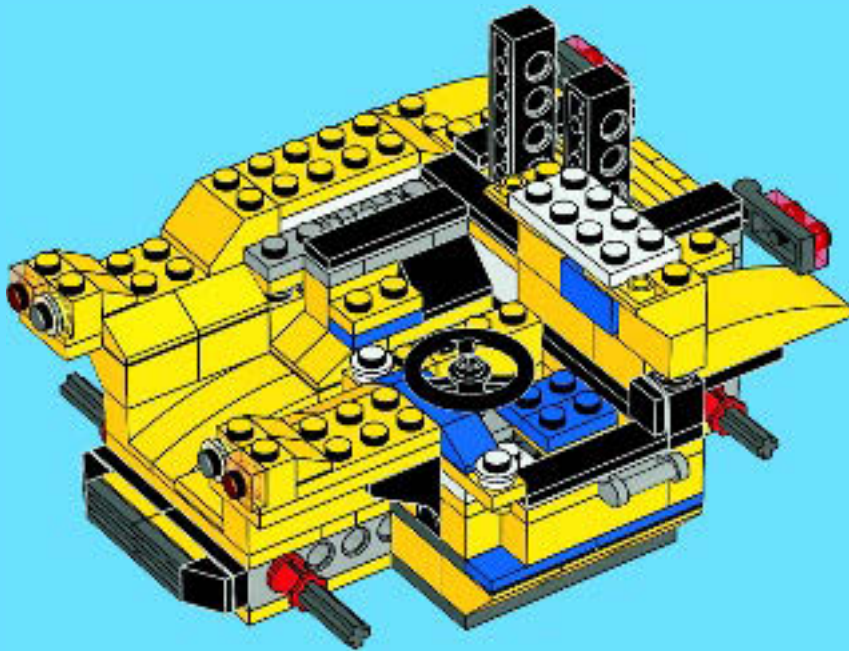

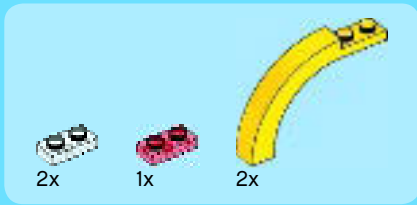

45

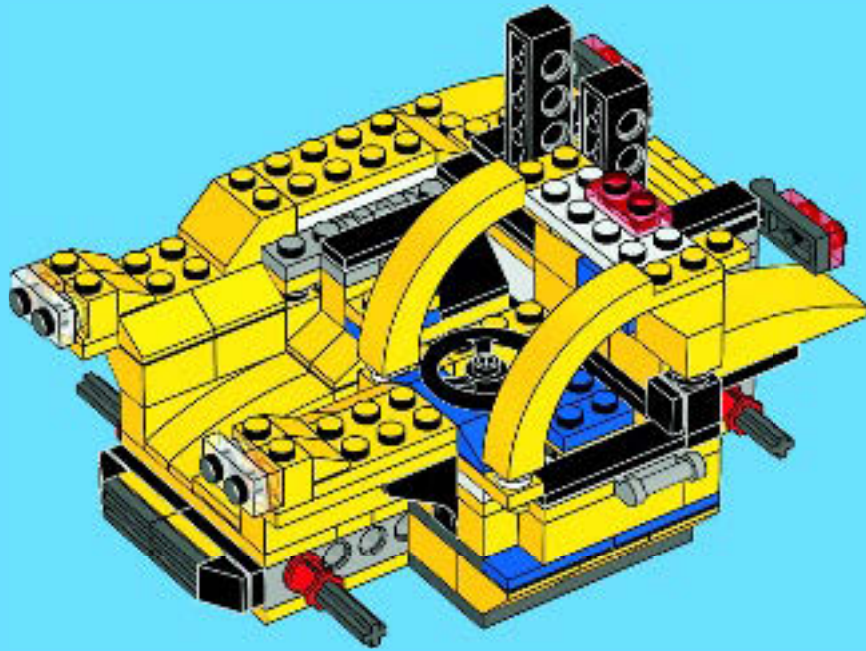



1x



4x

# 46

1



2

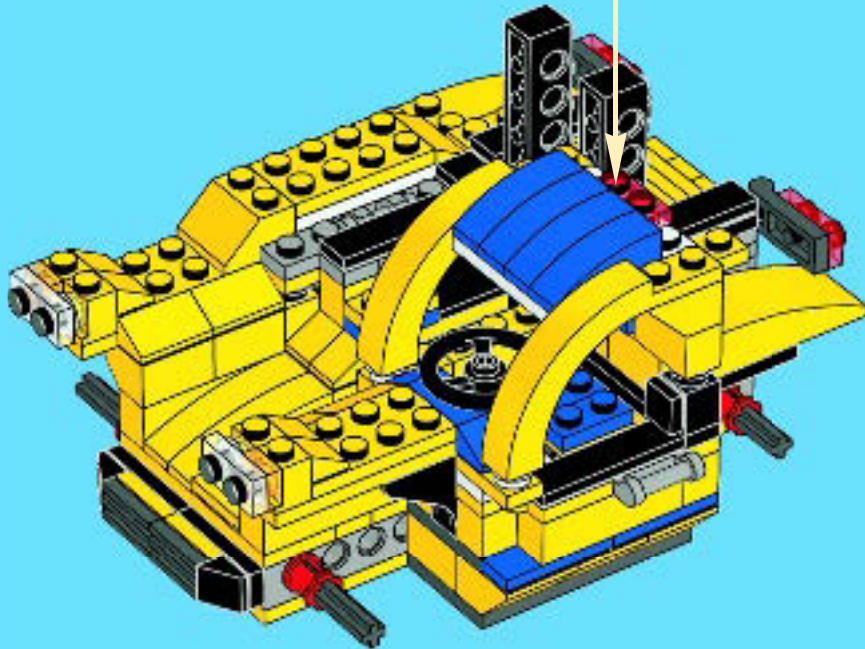
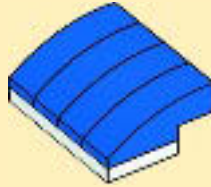





2x



2x



2x



2x

# 47

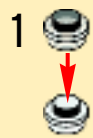

1

2



2x



2x

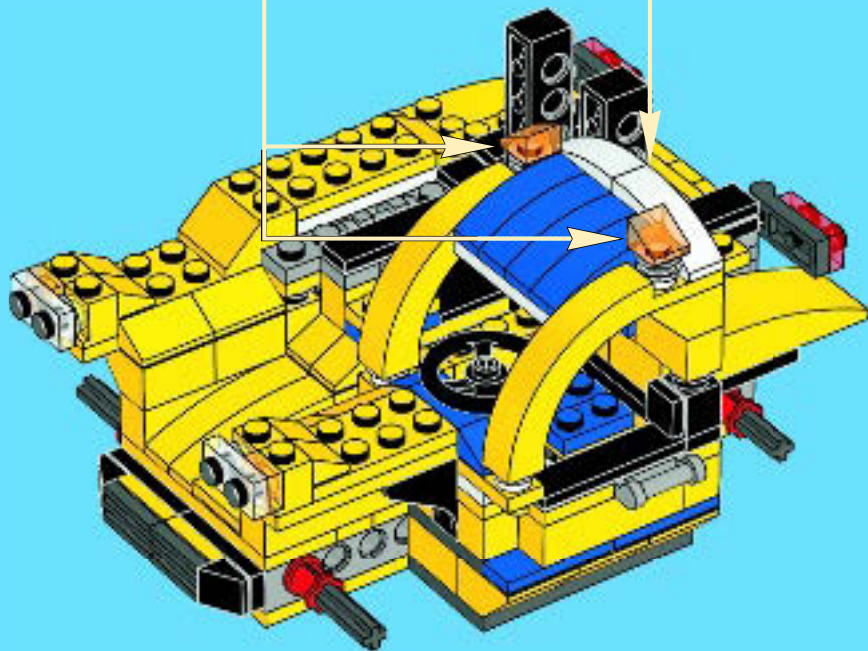

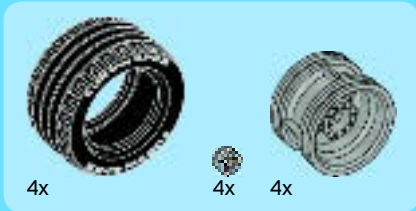

48

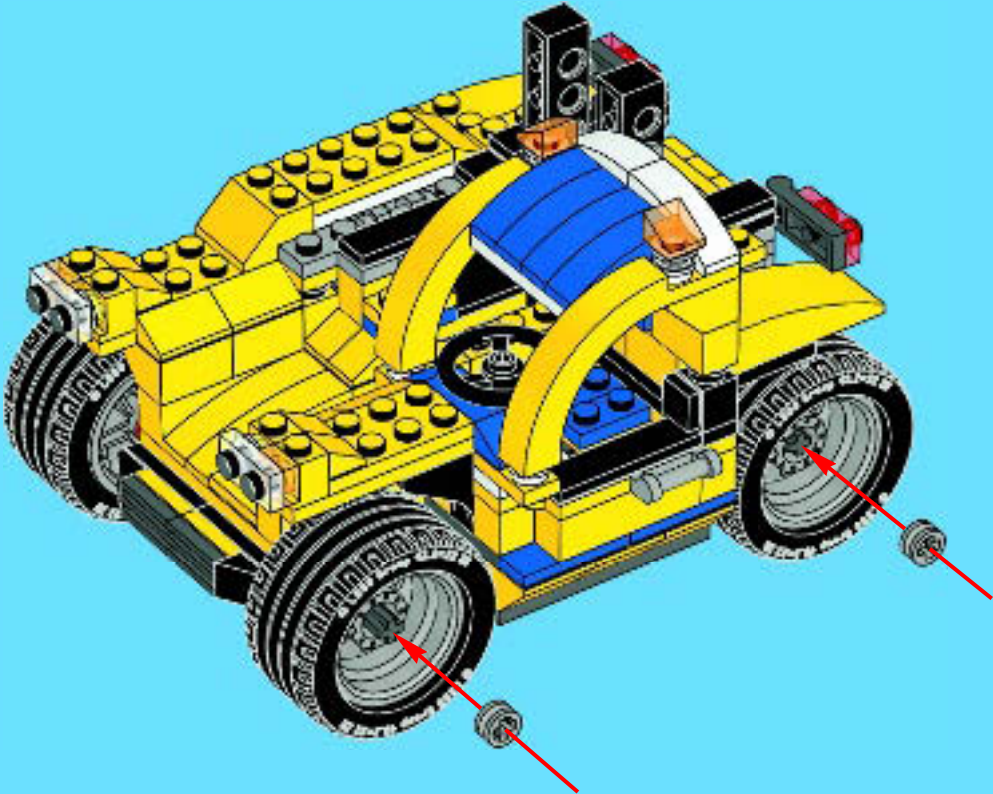

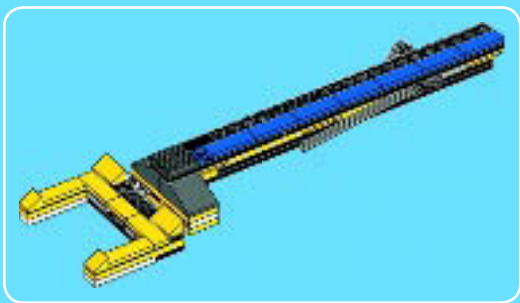

1

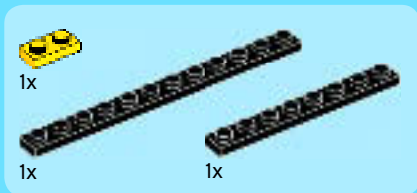
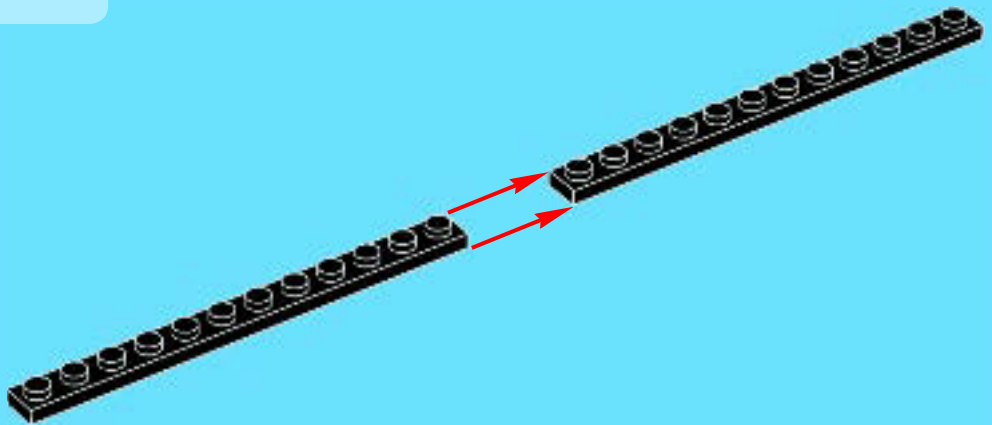

2

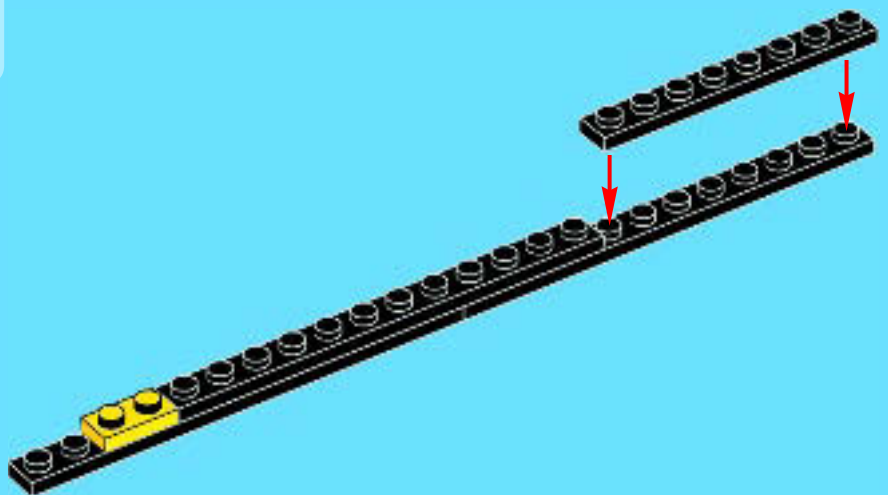



3

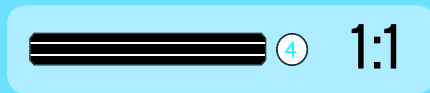
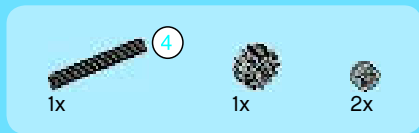
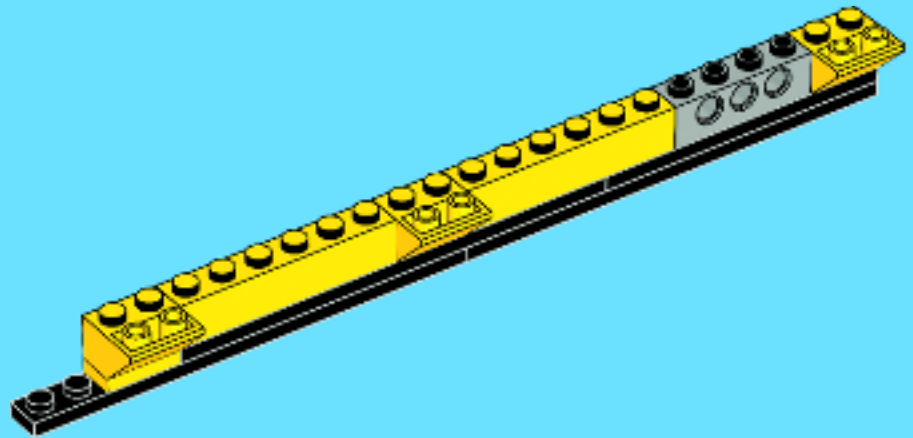

4

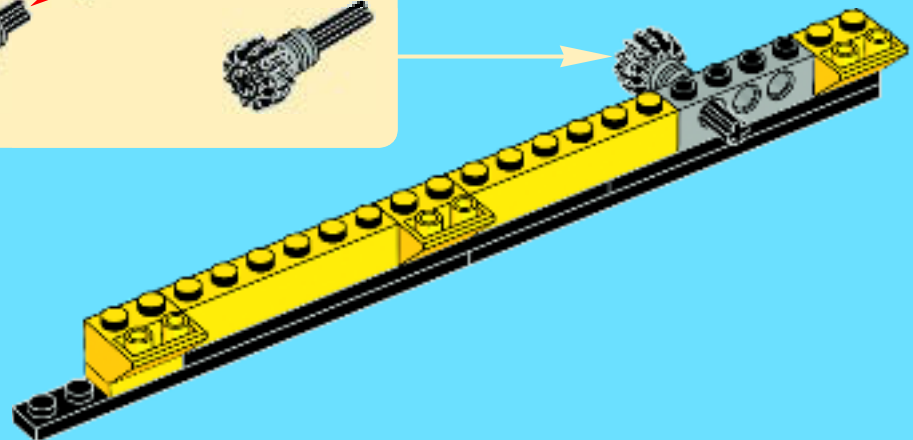
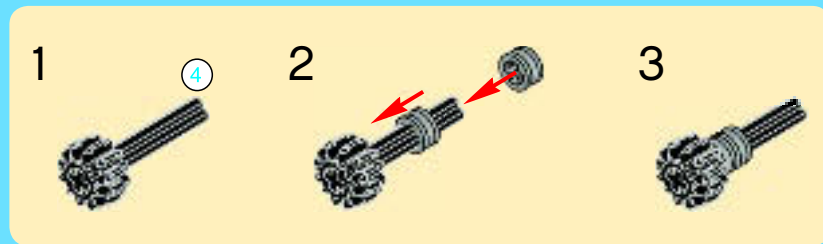

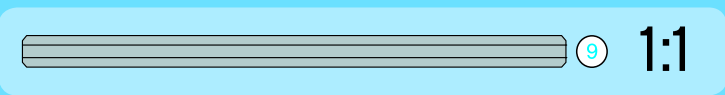
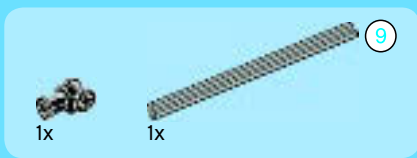

5

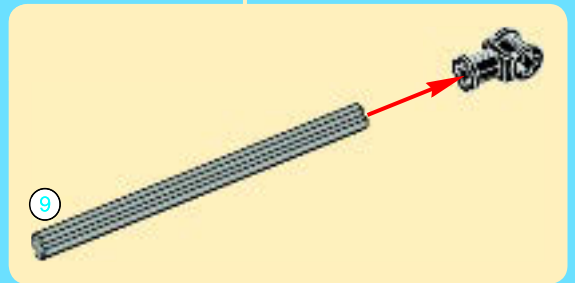
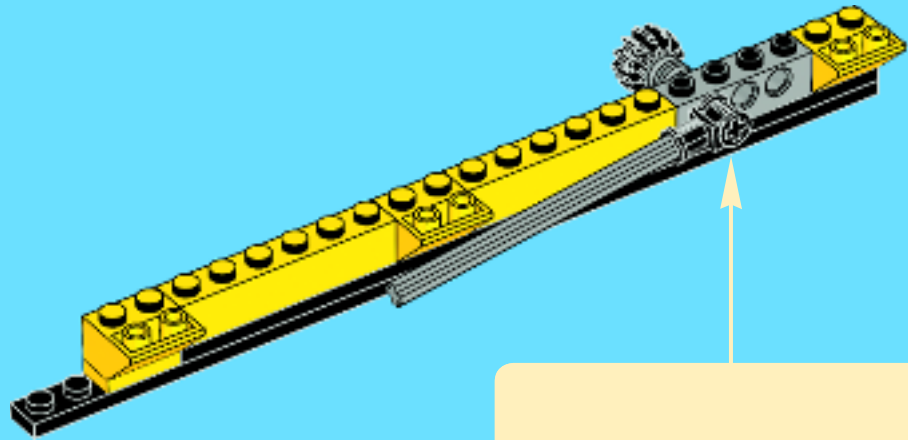

6

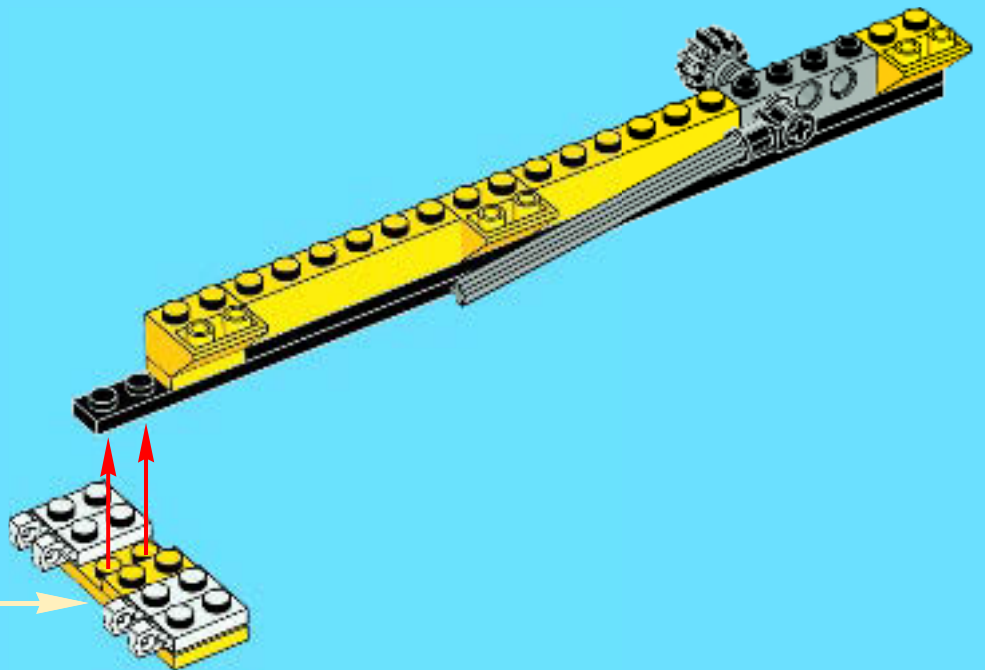
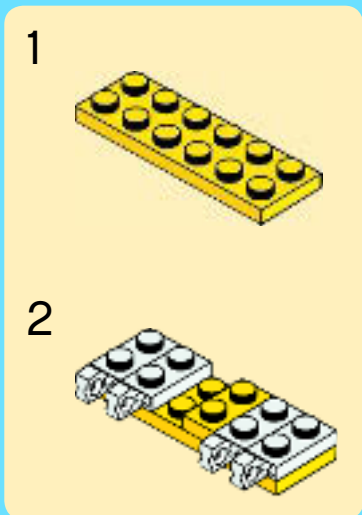



1x



2x

7

1

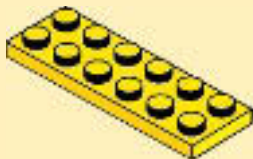

2

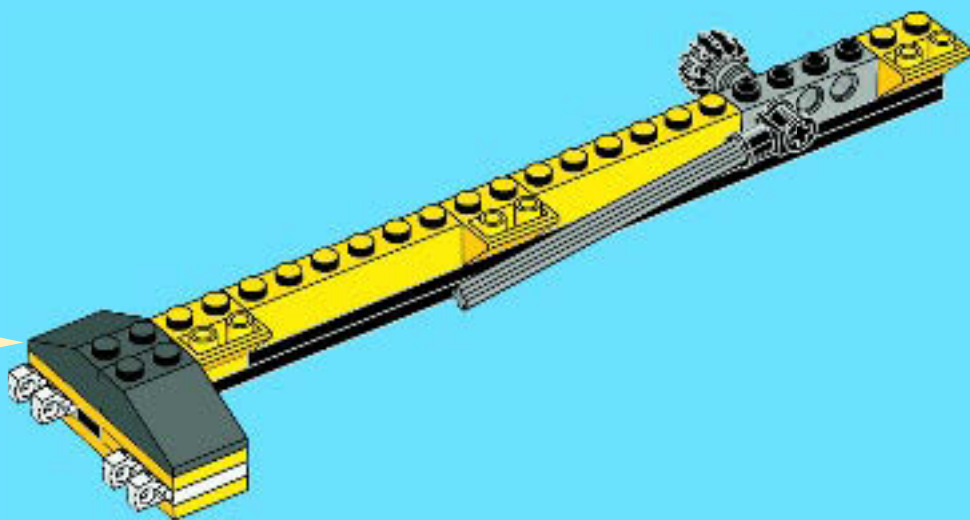
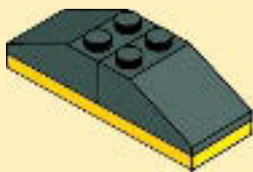

3x

8

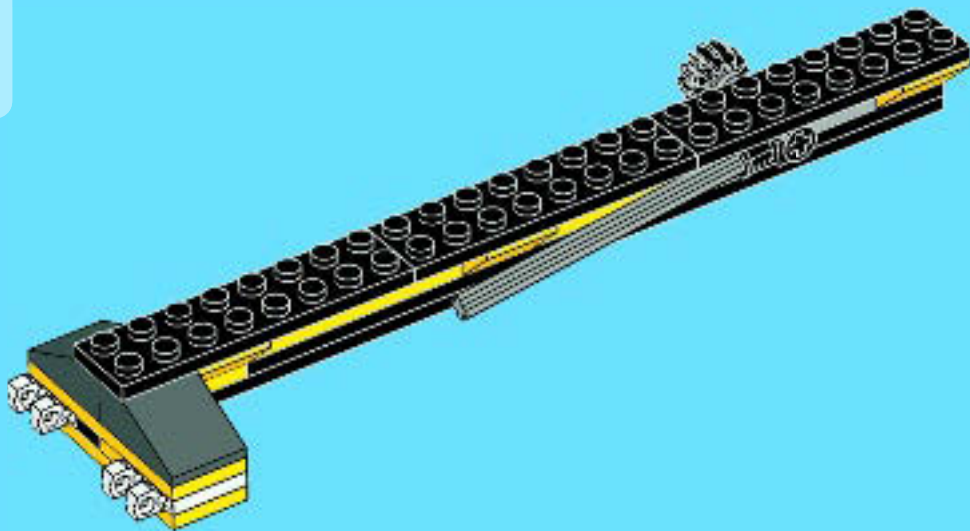

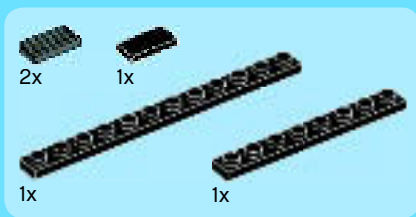

9

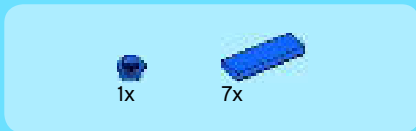
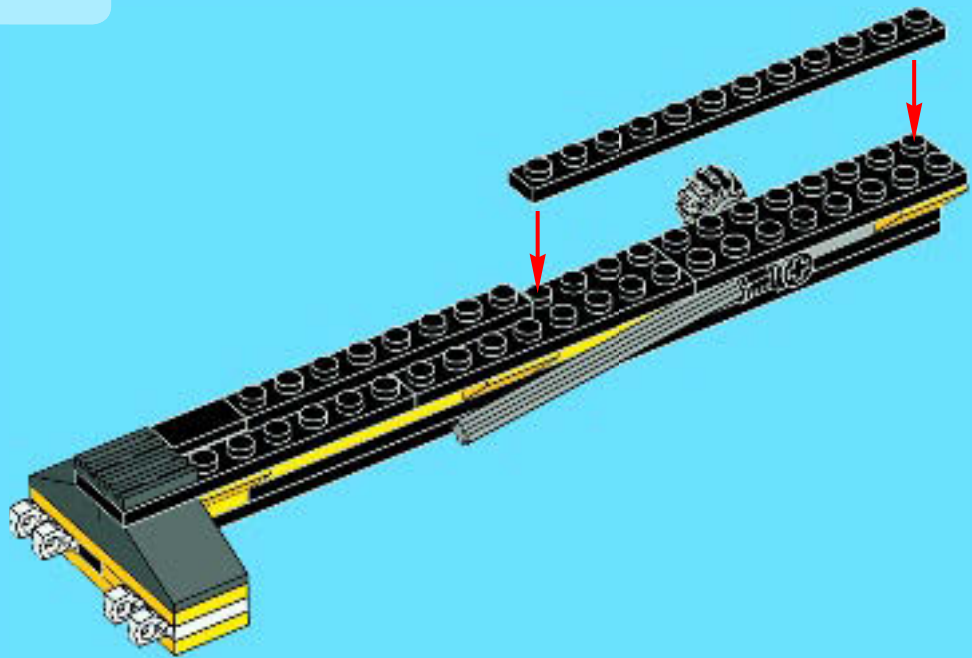

10

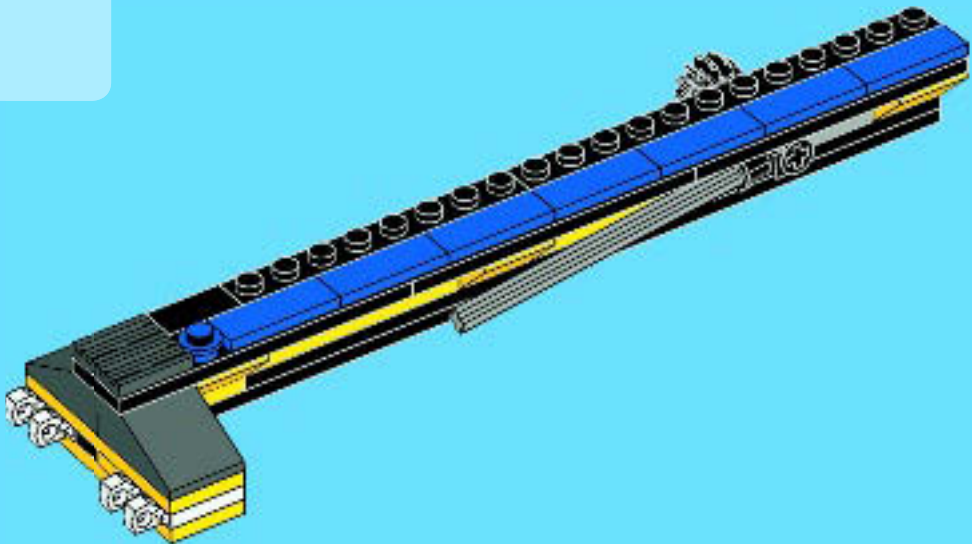

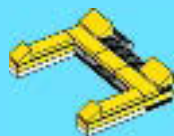

1x

1



1x



4x

2

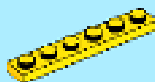

2x

3

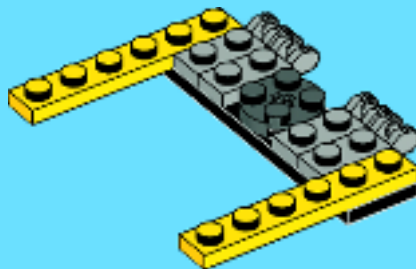





1x

4

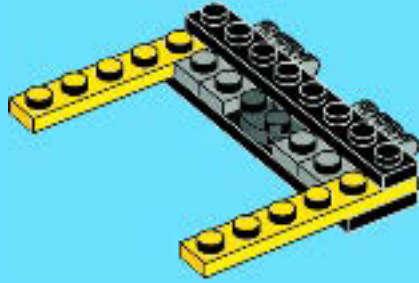

2x

5

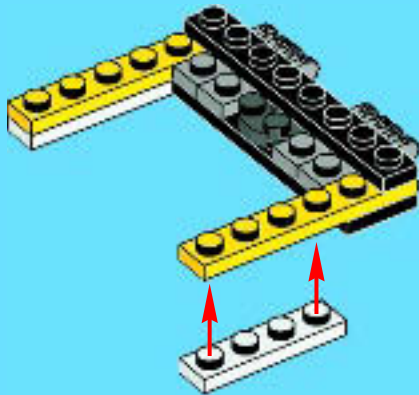



1x

4x

6

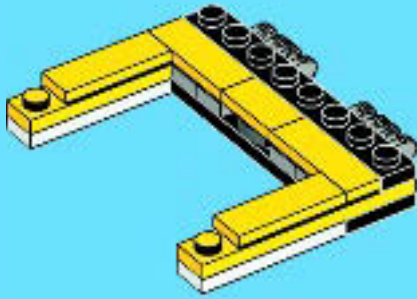

2x

2x

7

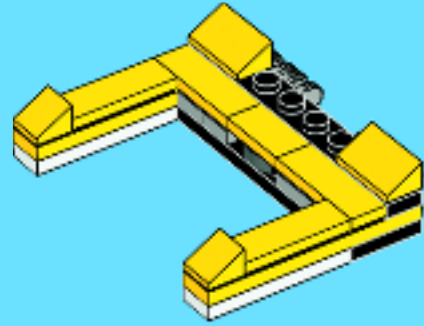

8

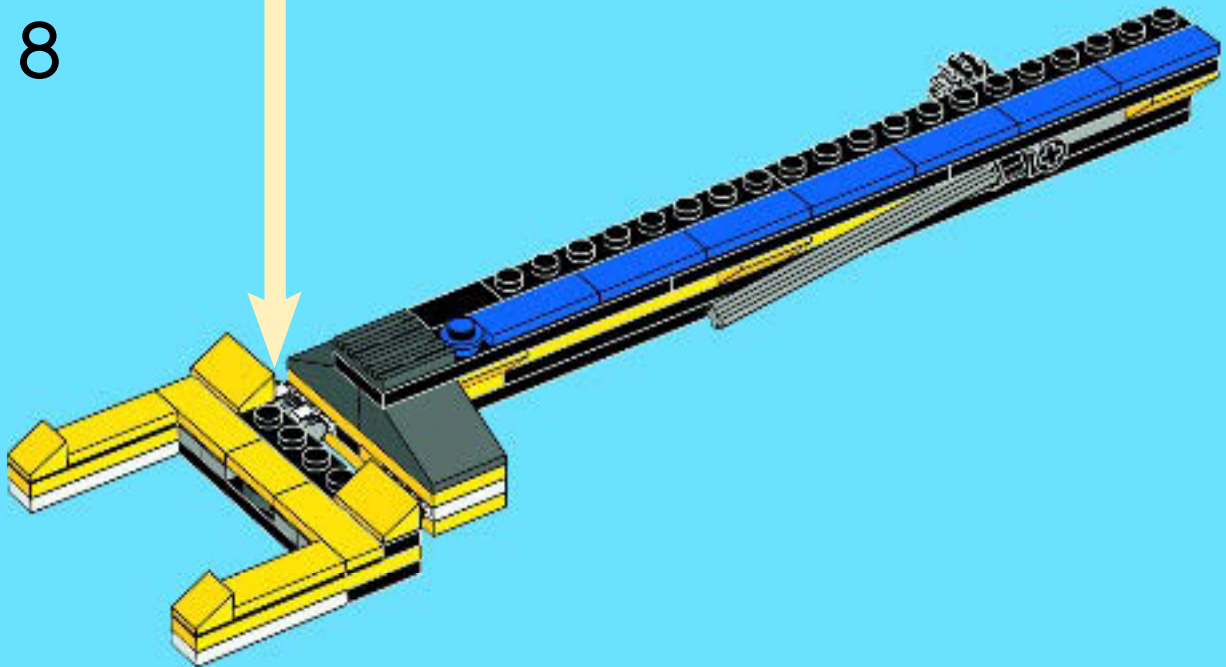

2x

1x

5

5

1:1

# 49

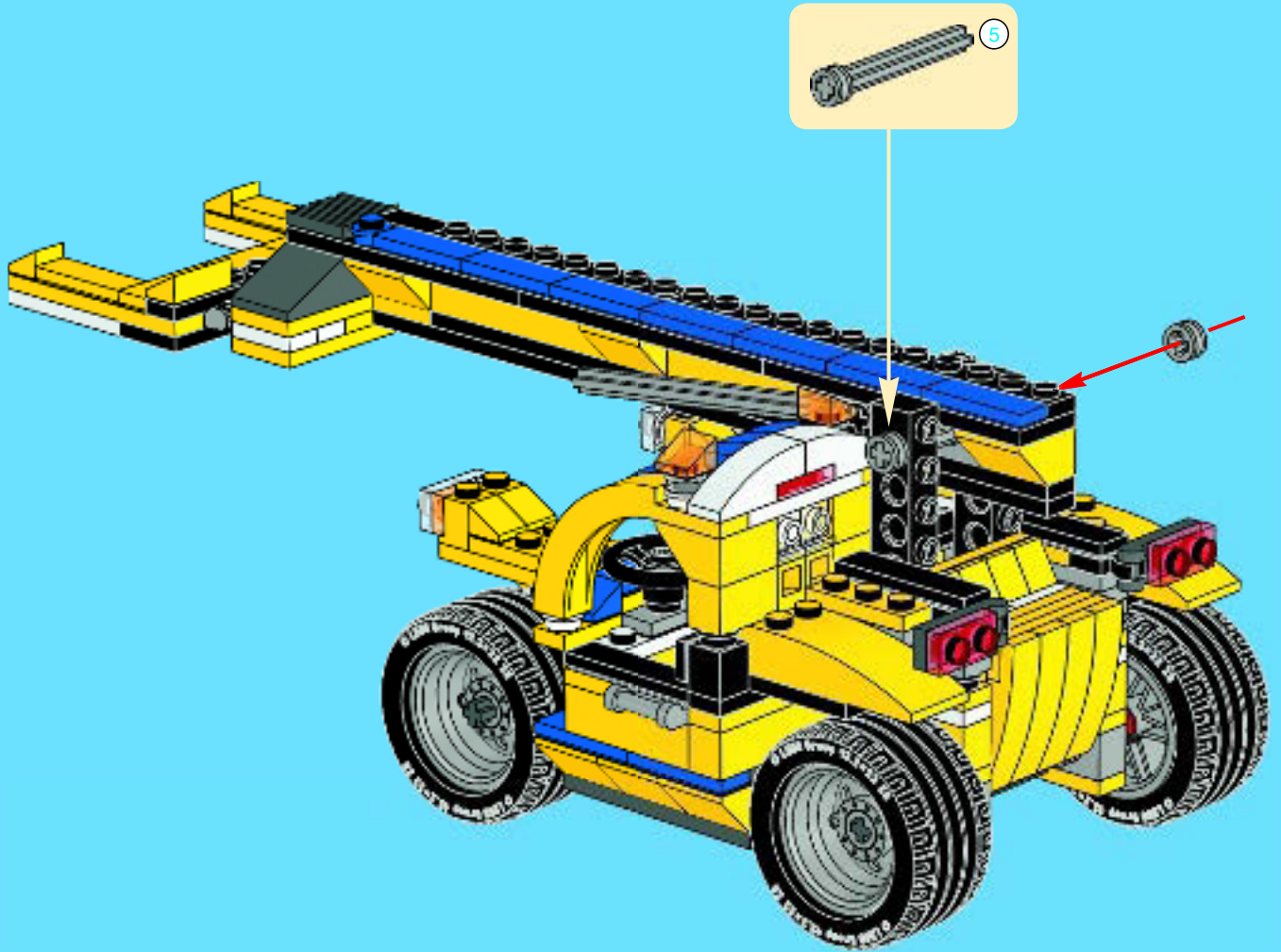

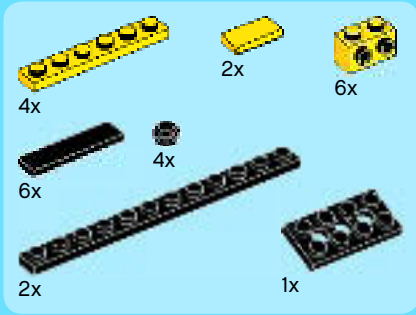

# 50

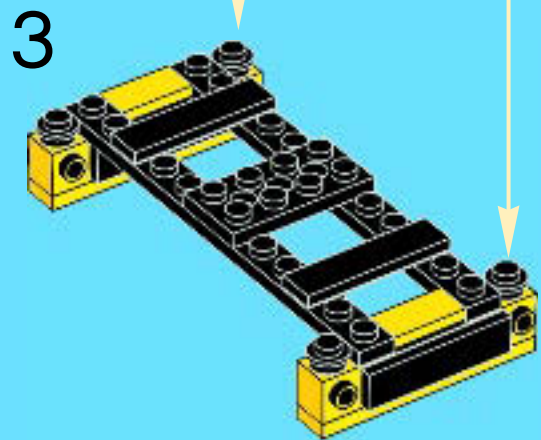
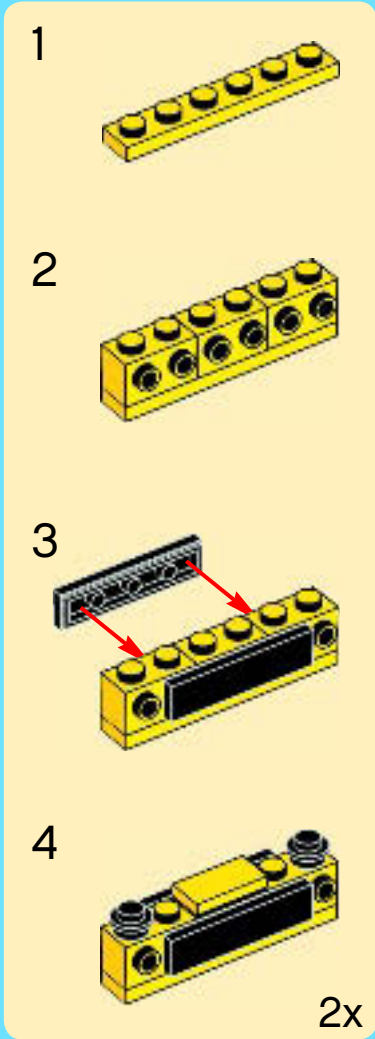
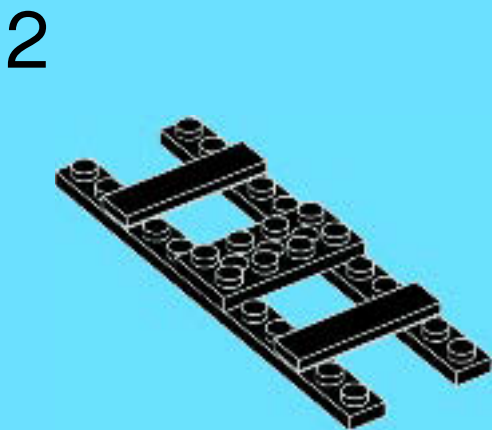
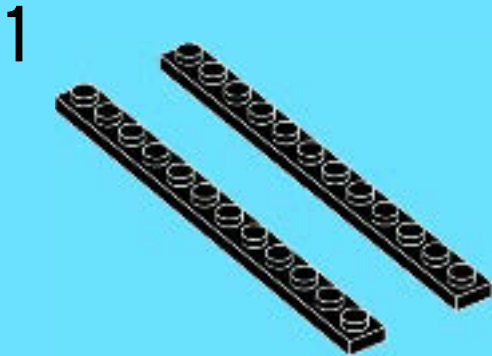

4

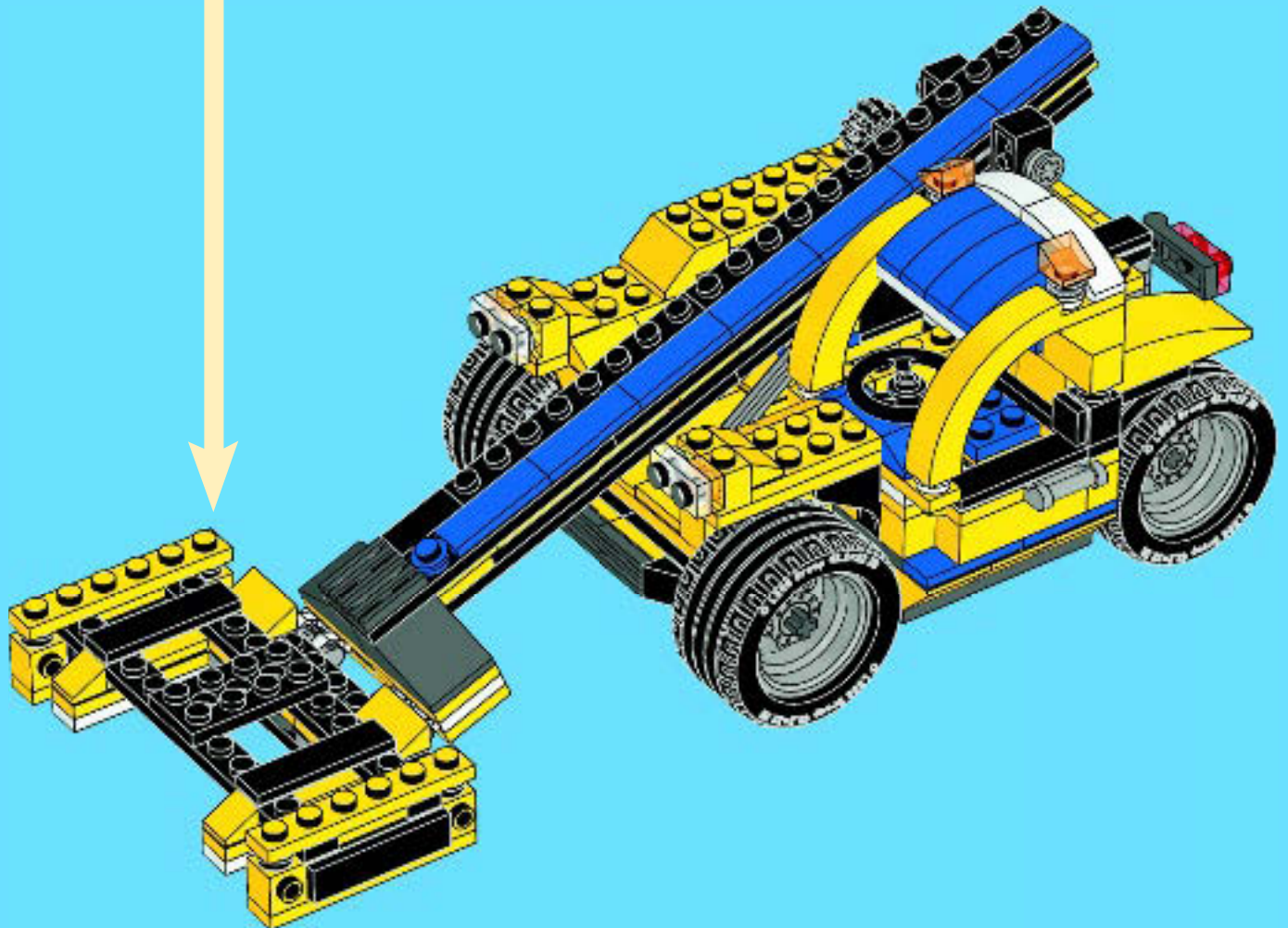
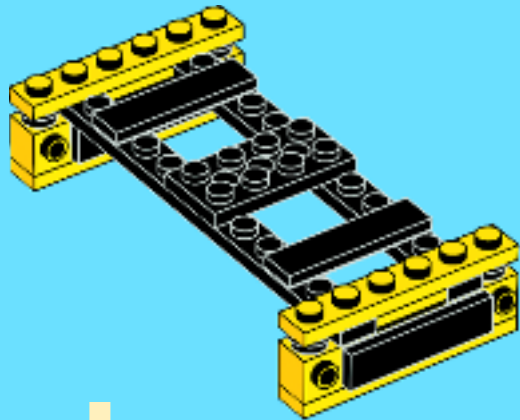



2x



2x

# 51

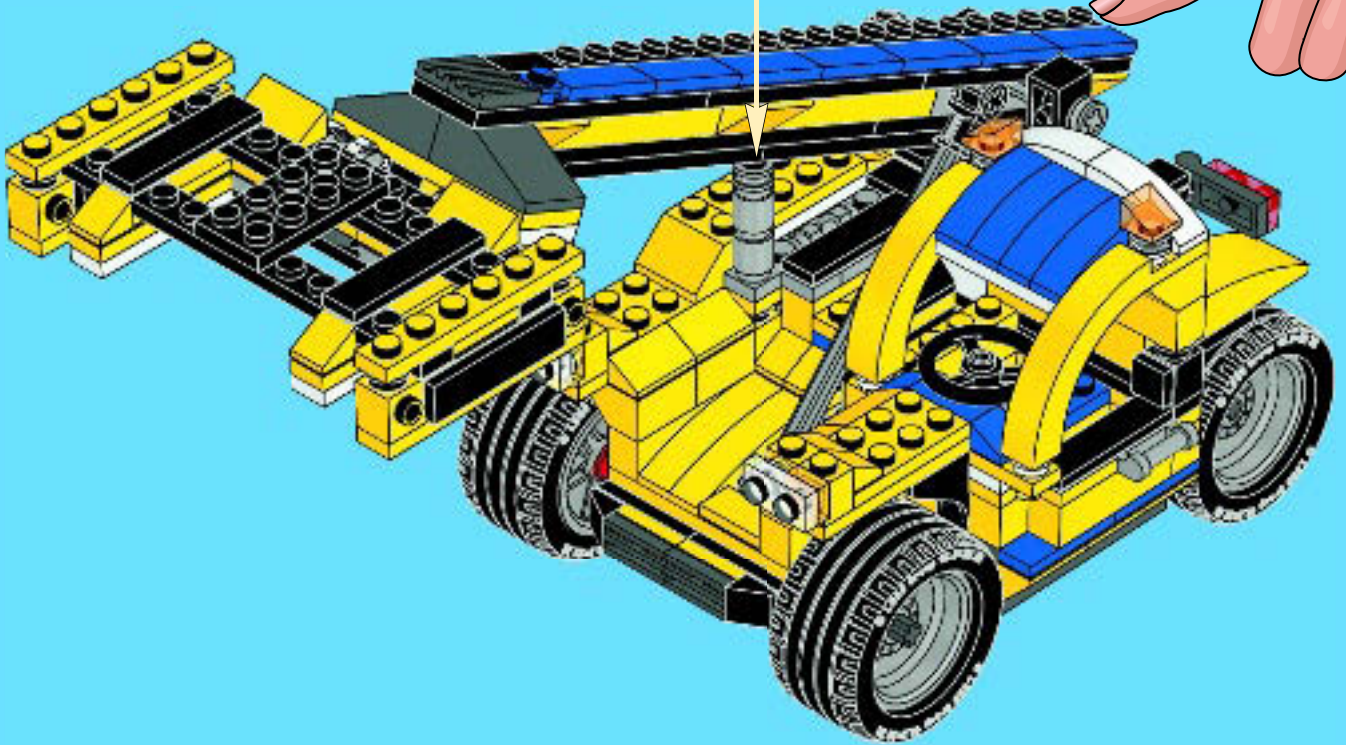
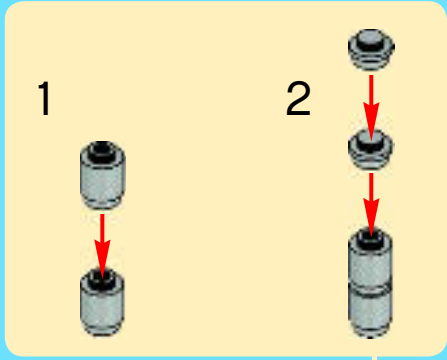

4x 4504380  
 4x 4543998  
 2x 306923  
 8x 302323  
 14x 4587840  
 2x 614123  
 2x 4143005  
 4x 4514553  
 3x 4210636  
 2x 4211106  
 4x 4210797  
 4x 4210631  
 1x 4210660  
 6x 4521187  
 1x 4225733  
 2x 4271344  
 1x 4211042  
 1x 4210694  
 4x 4516546  
 2x 4560177  
 2x 4508553  
 2x 4514559  
 4x 4211050

2x 362201  
 2x 300201  
 2x 4249112  
 8x 302101  
 5x 371001  
 2x 243101  
 7x 302001  
 4x 4183035  
 4x 614101  
 10x 407024  
 10x 4557157  
 18x 4504381  
 10x 366524  
 7x 4550348  
 8x 4121965  
 2x 4264338  
 2x 303924  
 18x 366024  
 14x 4522035  
 2x 421114

14x 300424  
 6x 362224  
 5x 301024  
 2x 300924  
 5x 302224  
 4x 302124  
 9x 3710  
 7x 302024  
 10x 366624  
 7x 379524  
 2x 4282745  
 4x 4160392  
 2x 4625813  
 2x 4180546  
 2x 4501536  
 2x 4271084  
 2x 4271087  
 1x 4625815  
 1x 4625820

7x 306924  
 4x 306924  
 2x 242024  
 12x 302324  
 12x 362324  
 6x 4558172  
 4x 4205196  
 2x 4179095  
 2x 4179094  
 2x 307026  
 4x 306926  
 12x 243126  
 2x 4558954  
 4x 4162443  
 2x 4584274  
 4x 4598528  
 6x 4504382  
 4x 303926  
 2x 4581280  
 2x 4243819  
 2x 300126  
 1x 4181144

10x 614126  
 4x 4550017  
 1x 4180508  
 1x 4180536  
 1x 4580509  
 1x 4107081  
 6x 4121715  
 1x 4526982  
 1x 370526  
 2x 4114671  
 2x 4114670  
 1x 4177431  
 6x 362326  
 5x 371026  
 8x 346026  
 1x 379526  
 4x 303426  
 1x 303526  
 4x 273026  
 1x 4275503  
 9x 4514845

4x 302226  
 2x 306826  
 2x 4278359  
 3x 4548180  
 6x 370926  
 4x 4184286  
 3x 4666579  
 2x 4565452  
 2x 4179355  
 8x 614121  
 5x 4227155  
 2x 4215618  
 2x 4167842  
 8x 3005740  
 4x 4201019  
 2x 4244369  
 2x 4542673  
 2x 4211359  
 2x 4503416  
 1x 4211837

20x 4211412  
 5x 4211440  
 4x 4297210  
 1x 4227776  
 8x 4211353  
 5x 4541978  
 1x 4211451  
 2x 4244627  
 5x 4211804  
 6x 4211525  
 2x 4211628  
 14x 4211573  
 1x 4211375  
 3x 4211639  
 1x 4535768  
 1x 4251149  
 1x 4211462  
 2x 4211441  
 2x 4211705

Customer Service  
 Kundenservice  
 Service Consommateurs  
 Servicio Al Consumidor

www.lego.com/service or dial



: 00800 5346 5555

: 1-800-422-5346



# WIN!

Go to [www.LEGOsurvey.com/product](http://www.LEGOsurvey.com/product) to fill out a survey for a chance to win a cool LEGO® Product. No purchase necessary. Open to all residents where not prohibited.

 [www.LEGO.com](http://www.LEGO.com)

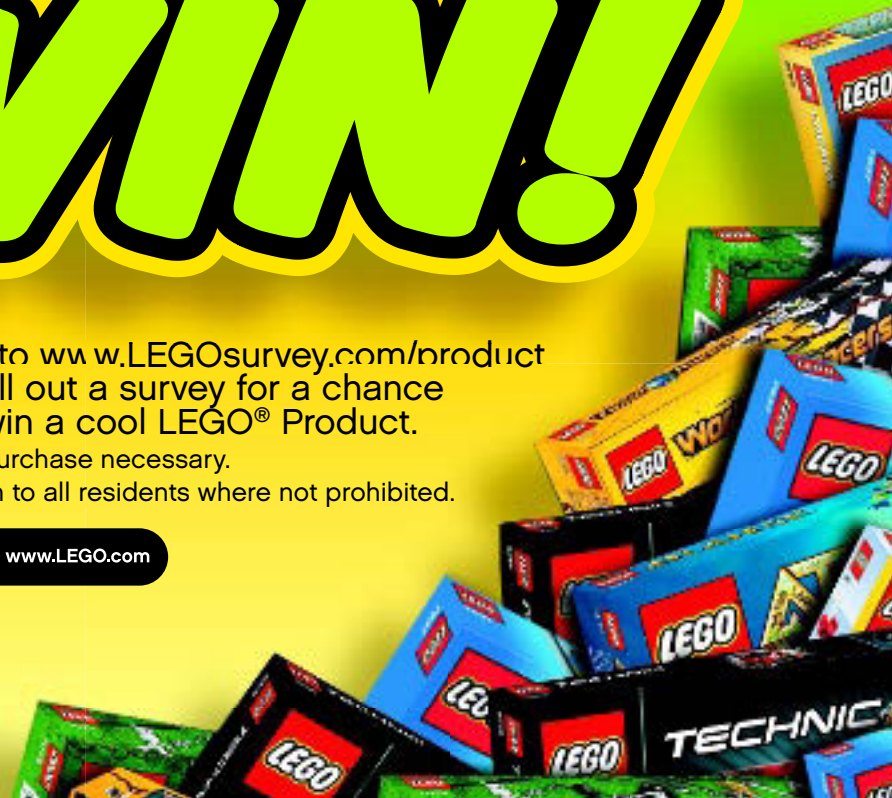

## [www.LEGOsurvey.com/product](http://www.LEGOsurvey.com/product)

### GEWINNE!

Nimm an der Umfrage auf [www.LEGOsurvey.com/product](http://www.LEGOsurvey.com/product) teil und hab die Chance ein cooles LEGO® Produkt zu gewinnen!

Die Teilnahme am Gewinnspiel führt zu keinerlei Kaufverpflichtungen. Teilnahme in allen nicht ausgeschlossenen Ländern möglich.

### WIN!

Ga naar [www.LEGOsurvey.com/product](http://www.LEGOsurvey.com/product), vul een enquêteformulier in en maak kans op een cool LEGO® product.

Geen aankoopverplichting. Iedereen mag deelnemen, uitgezonderd ingezetenden van landen waar een enquêteverbod geldt.

### GAGNE!

Visite [www.LEGOsurvey.com/product](http://www.LEGOsurvey.com/product) pour répondre à un questionnaire et avoir une chance de gagner un produit LEGO® très cool!

Aucune obligation d'achat. Ouvert à tous les résidents des pays autorisés.

### 当てよう!

[www.LEGOsurvey.com/product](http://www.LEGOsurvey.com/product) にアクセスして、アンケートにご記入ください。当選者にはレゴ®製品を差し上げます。

お買い上げの必要はありません。禁止されていない限り、すべての皆様にご利用いただけます。