



# CITY

60003



**WARNING: CHOKING HAZARD.**  
Small parts. Not for children under 3 years.

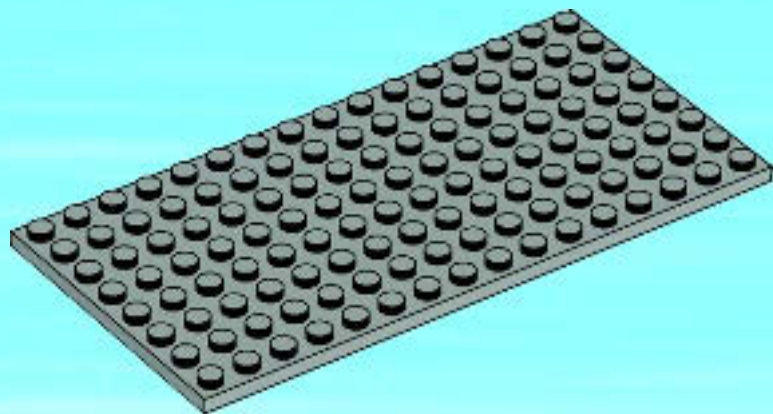
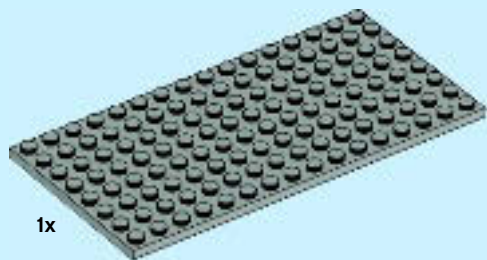

1

2



2x



**AVERTISSEMENT** : RISQUE D'ÉTOUFFEMENT.  
Contient des petites pièces. Ne convient pas aux enfants de moins de 3 ans.



**ADVERTENCIA**: PELIGRO DE ASFIXIA.  
No recomendado para niños menores de 3 años. Contiene piezas pequeñas.

2

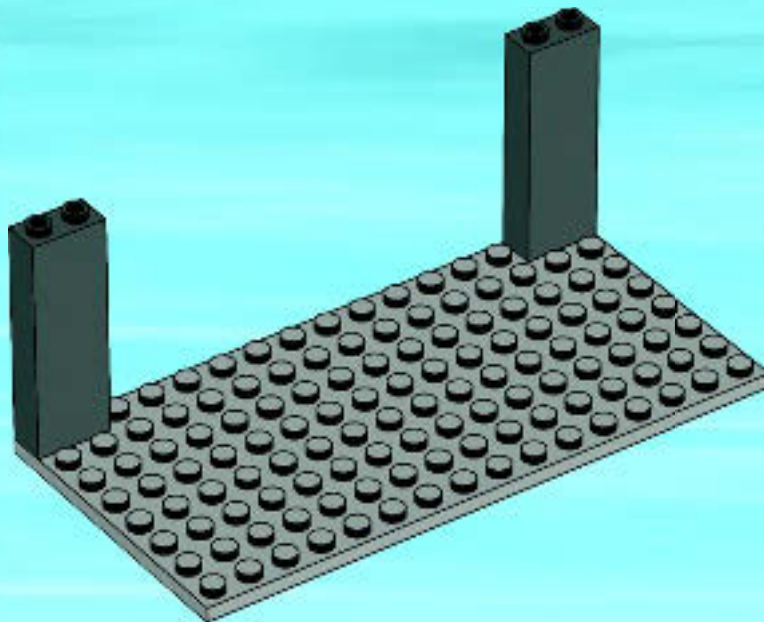



2x

3

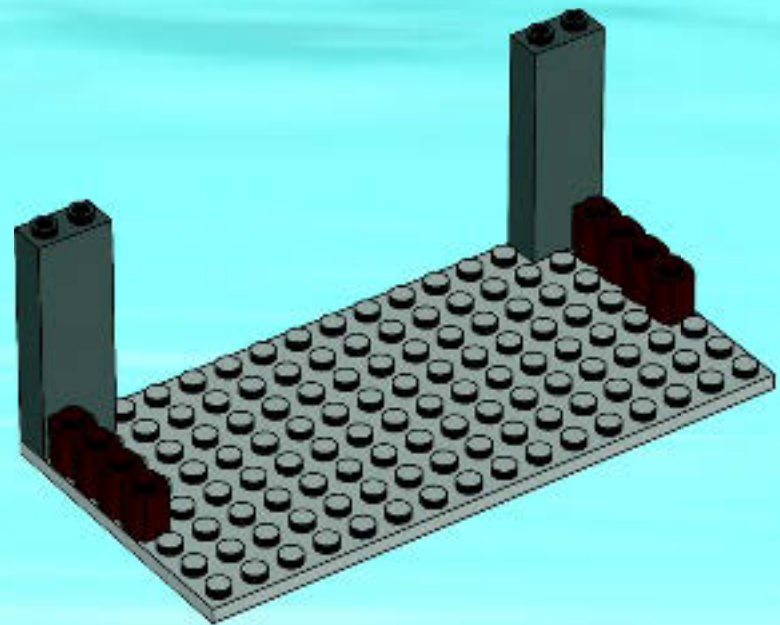

4



2x

4

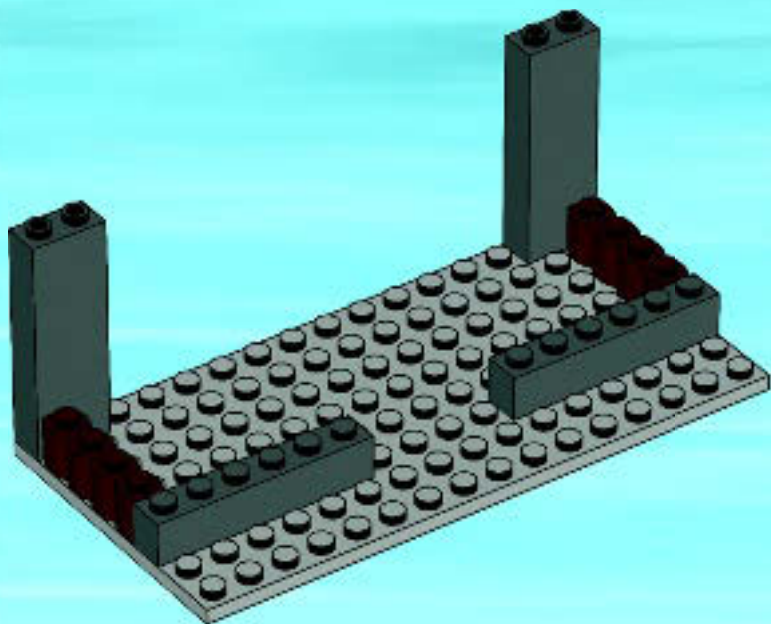



8x

5

1



2

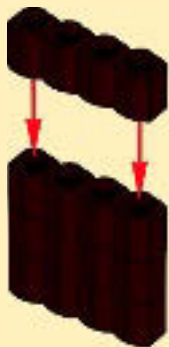

2x

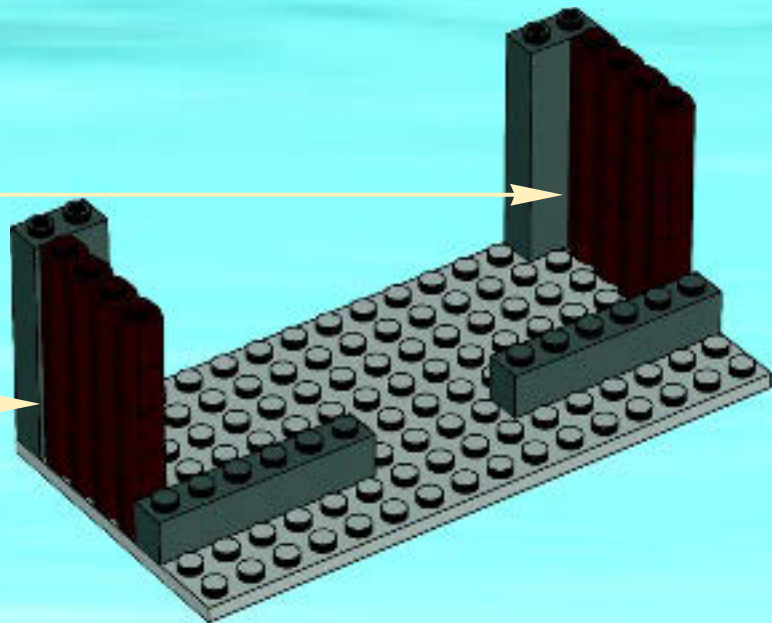

6



1x



1x

# 6

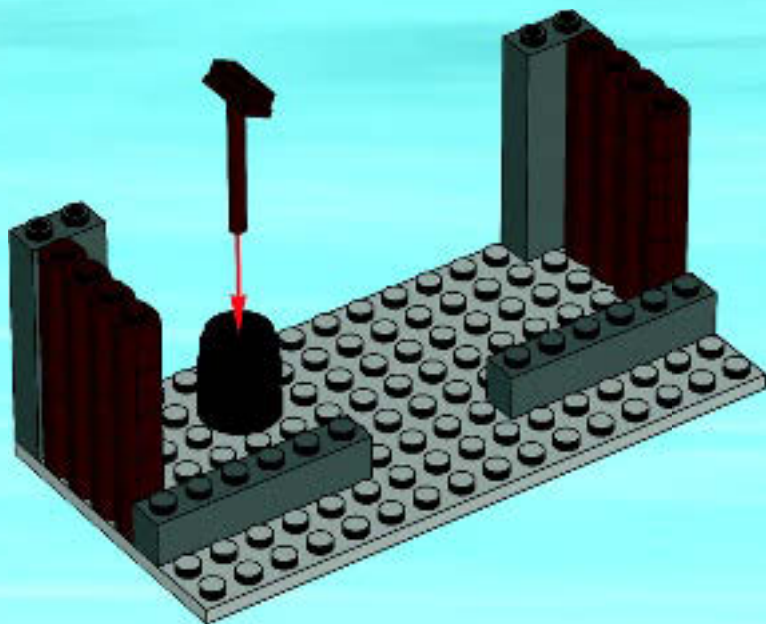



3x



3x

7

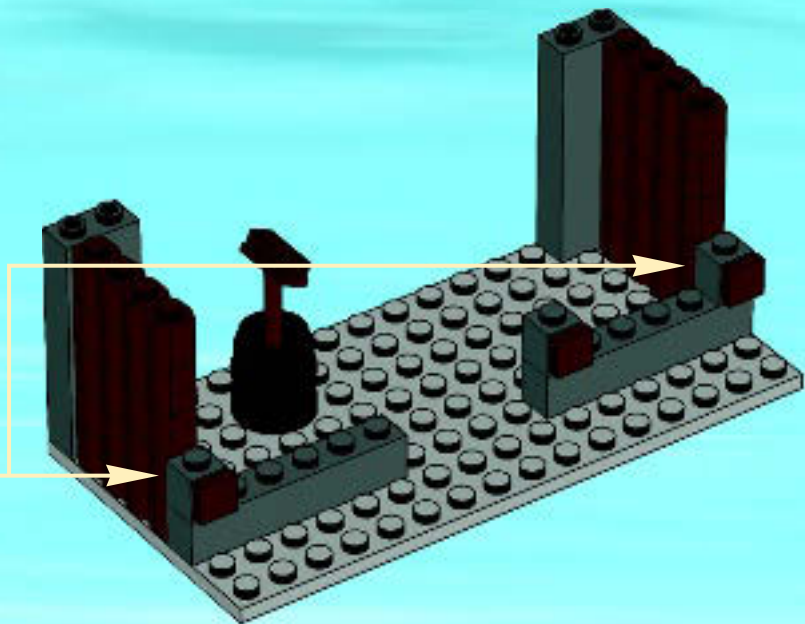
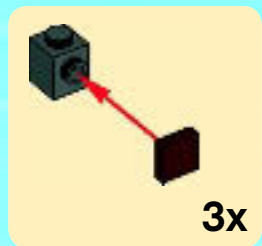

8





1x



2x

8

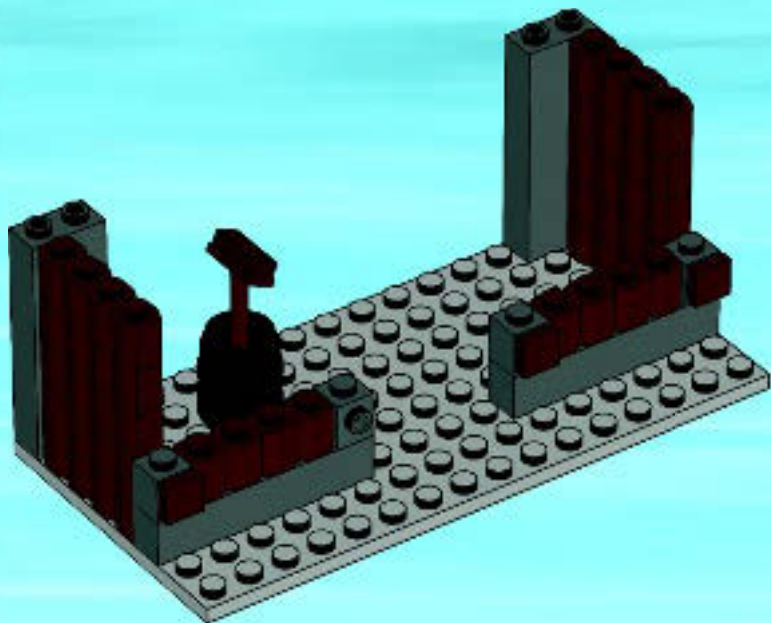



2x

9

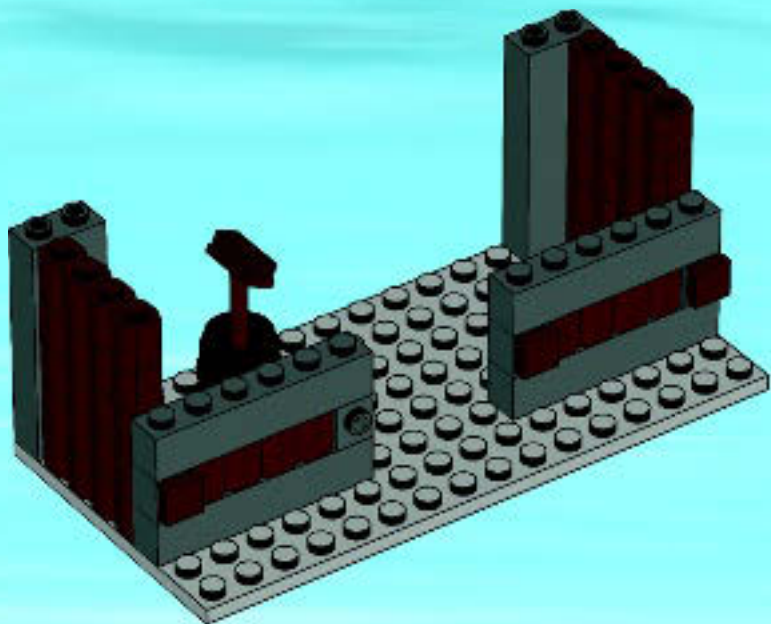

10



4x



3x

# 10

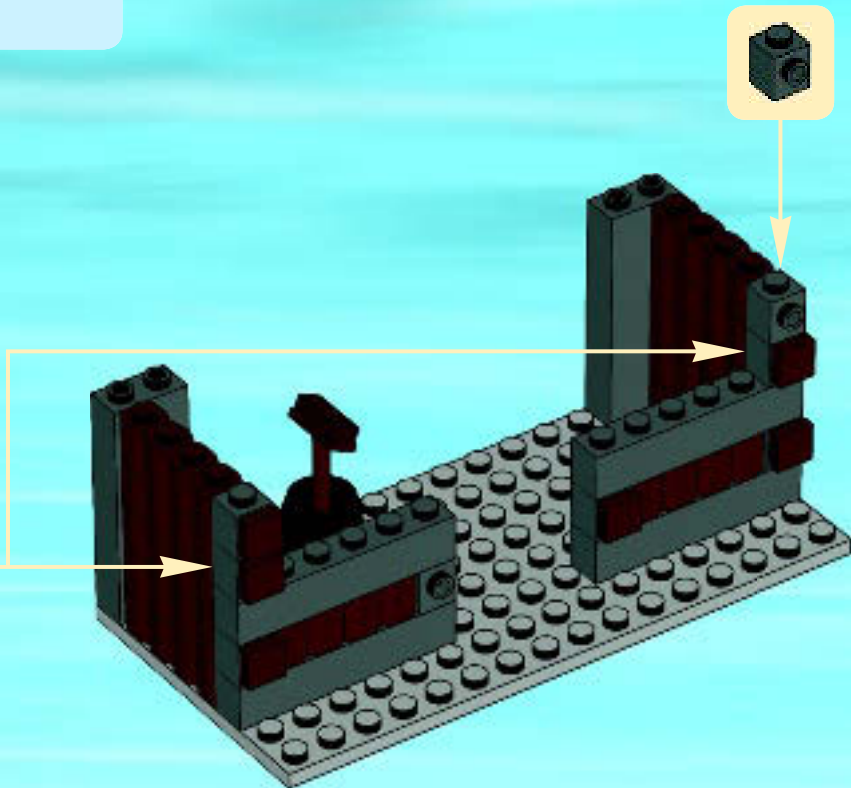
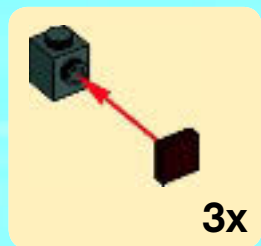



2x

11

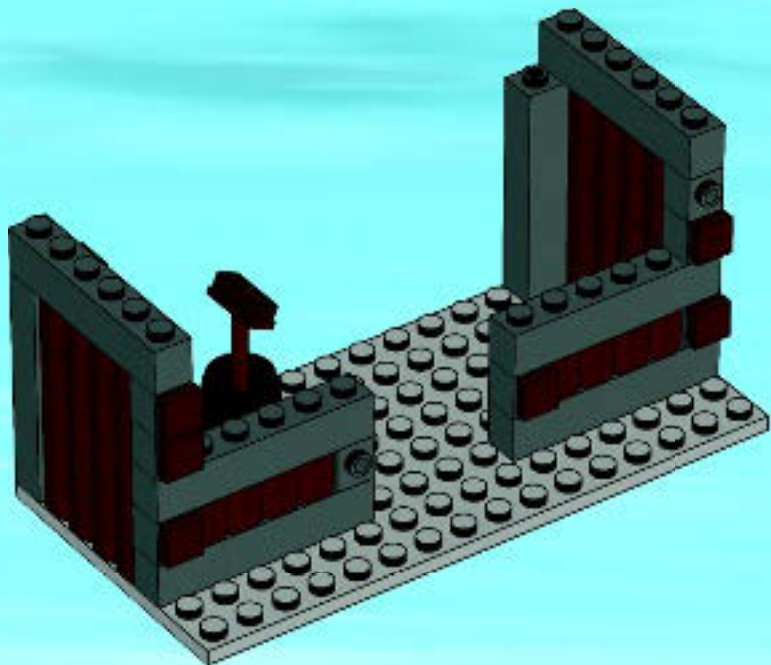

12



2x

12

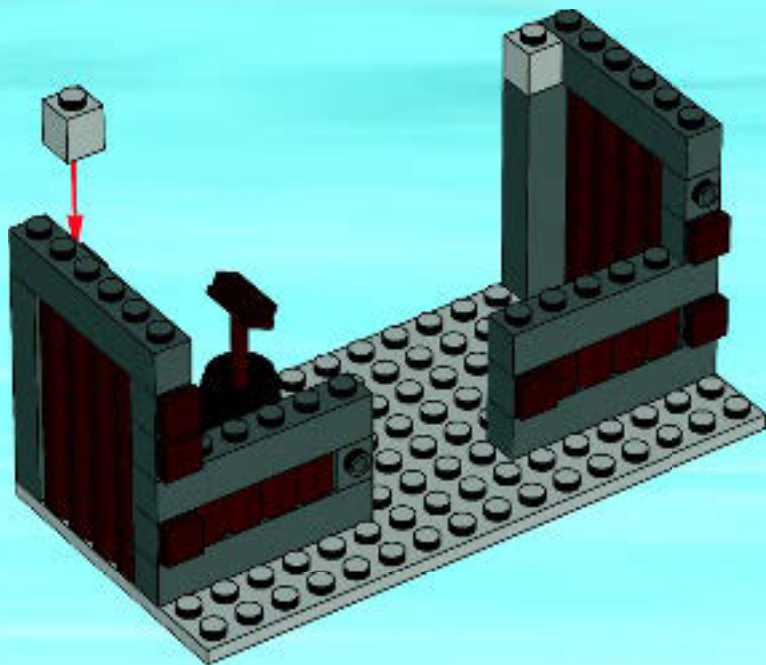

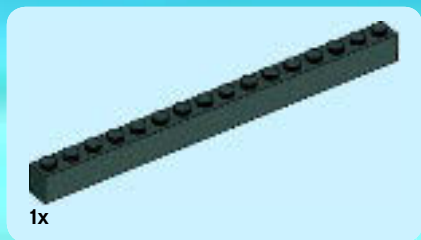

13

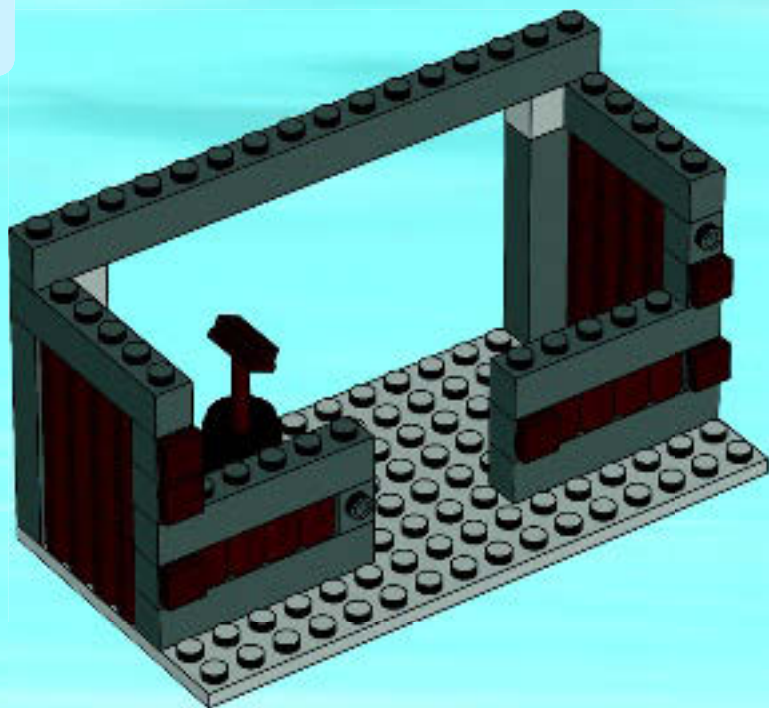



2x

14

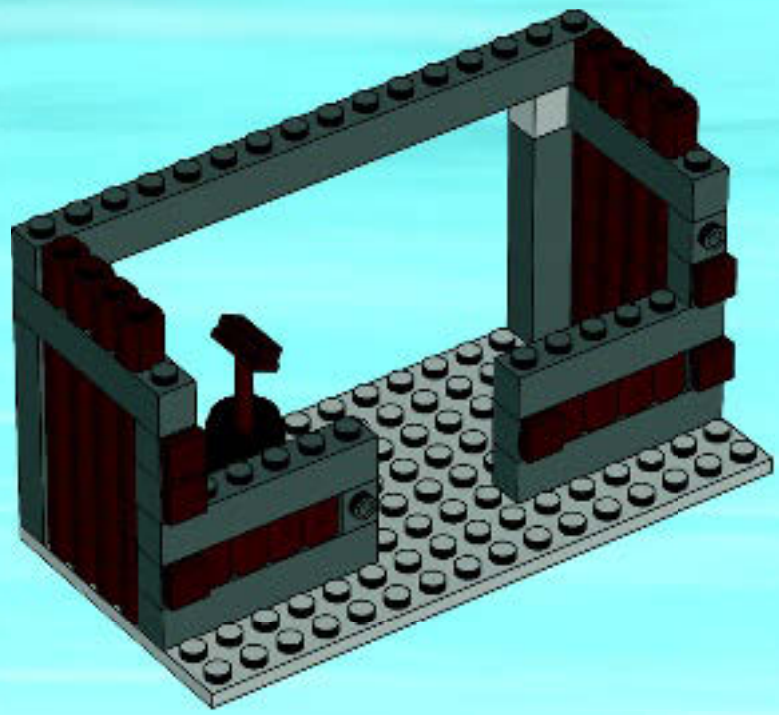



15

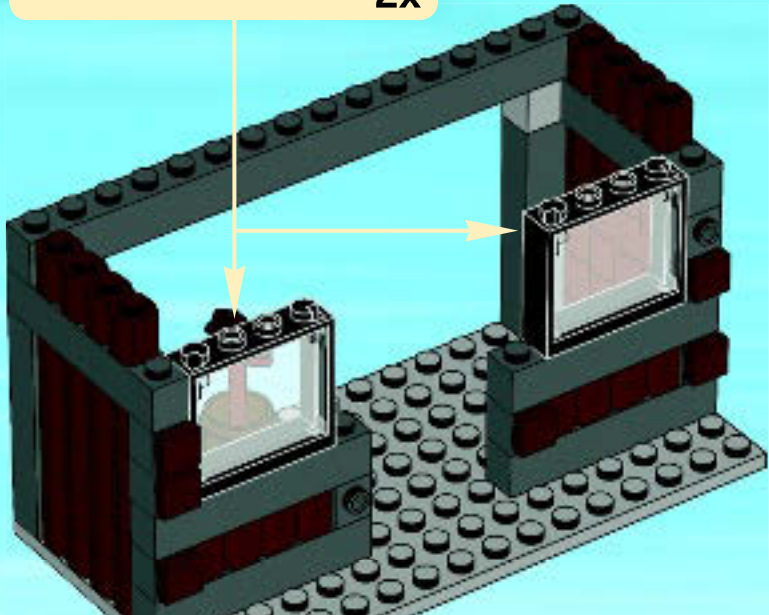
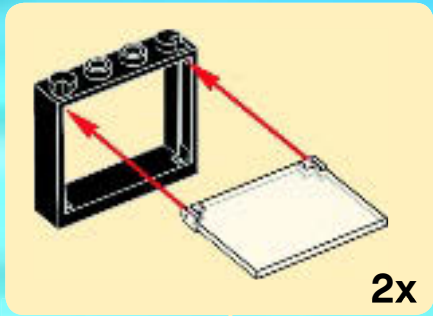





6x



4x

# 16

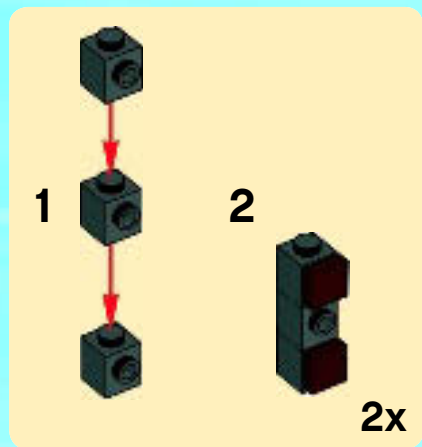
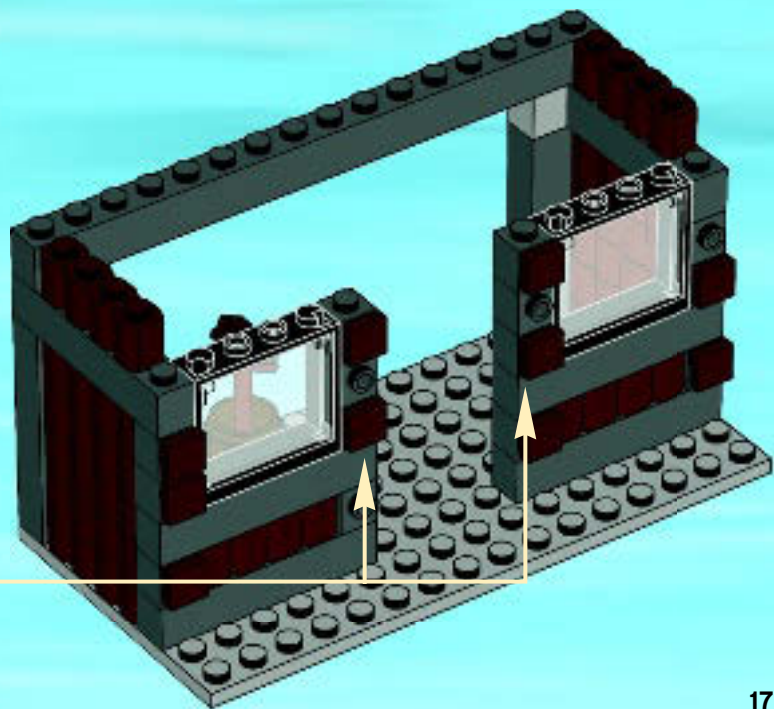

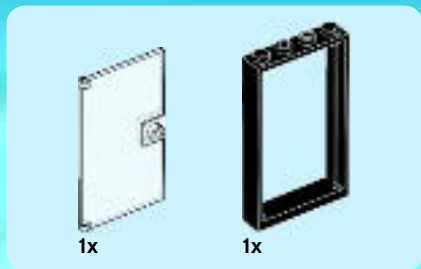

17

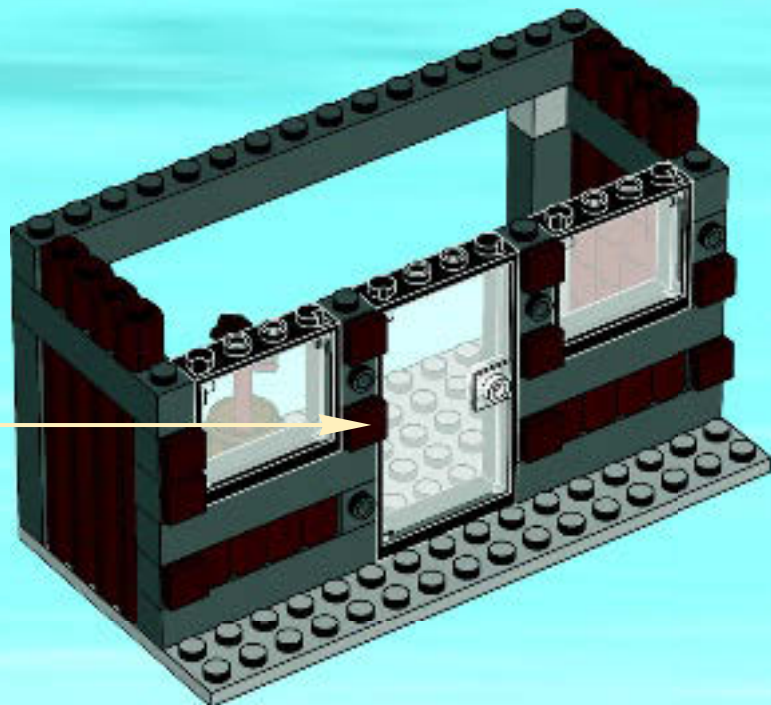
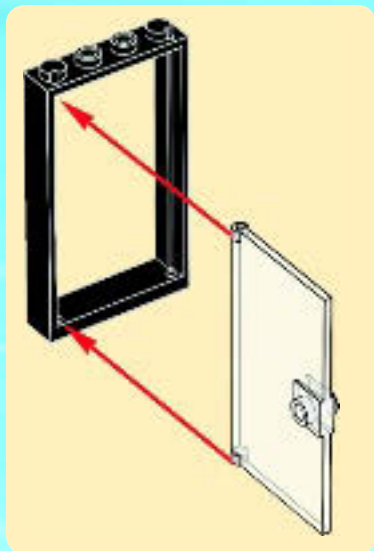

18

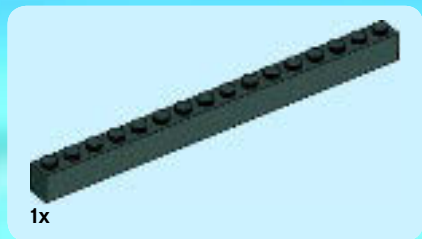

18

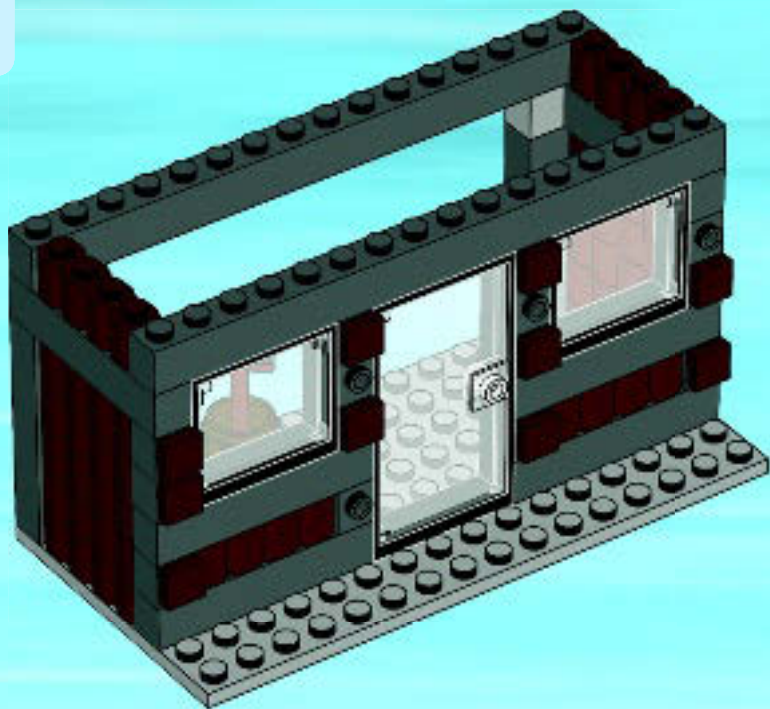



2x

19

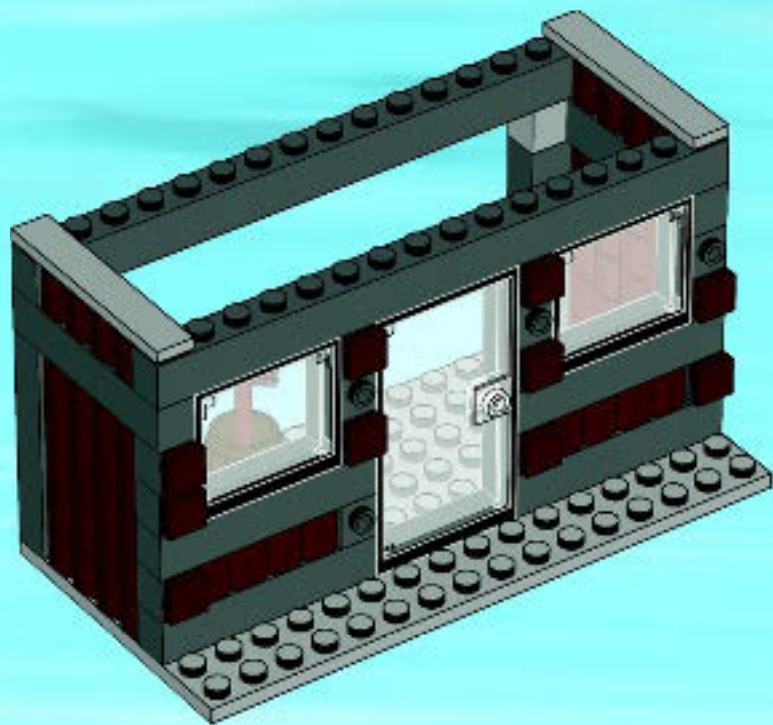

20



2x



4x

# 20

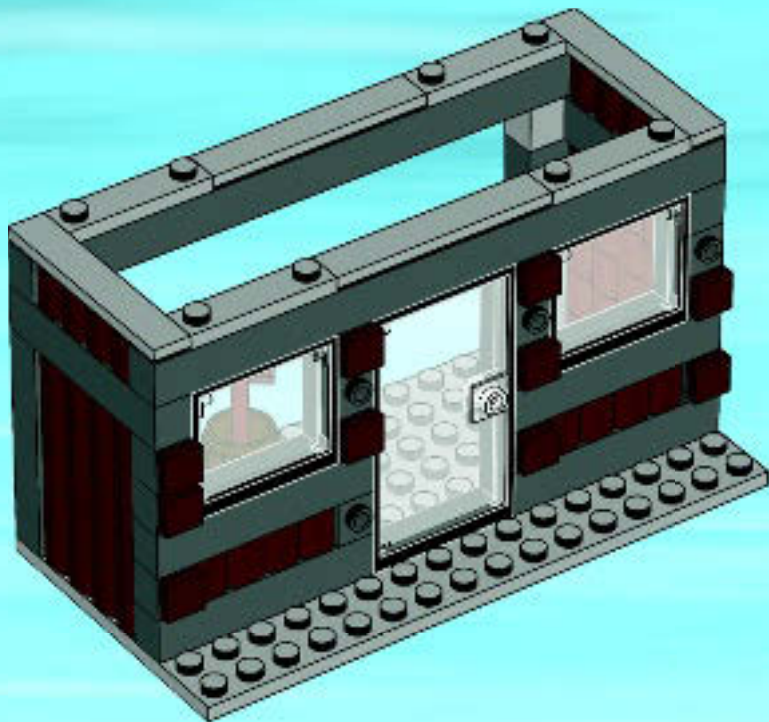



3x

21

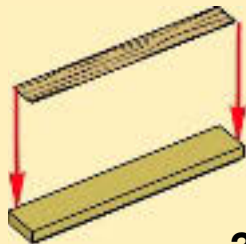
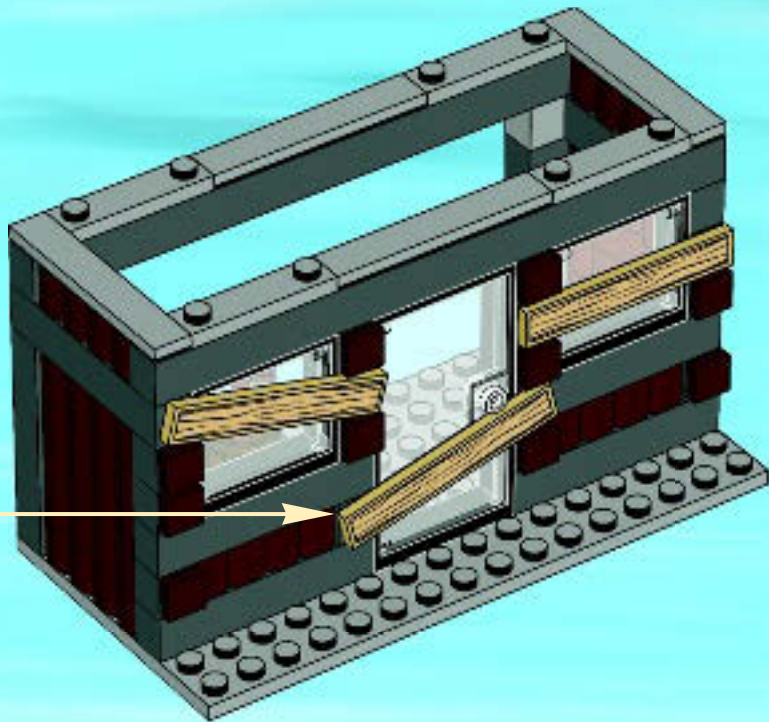

3x

22



22

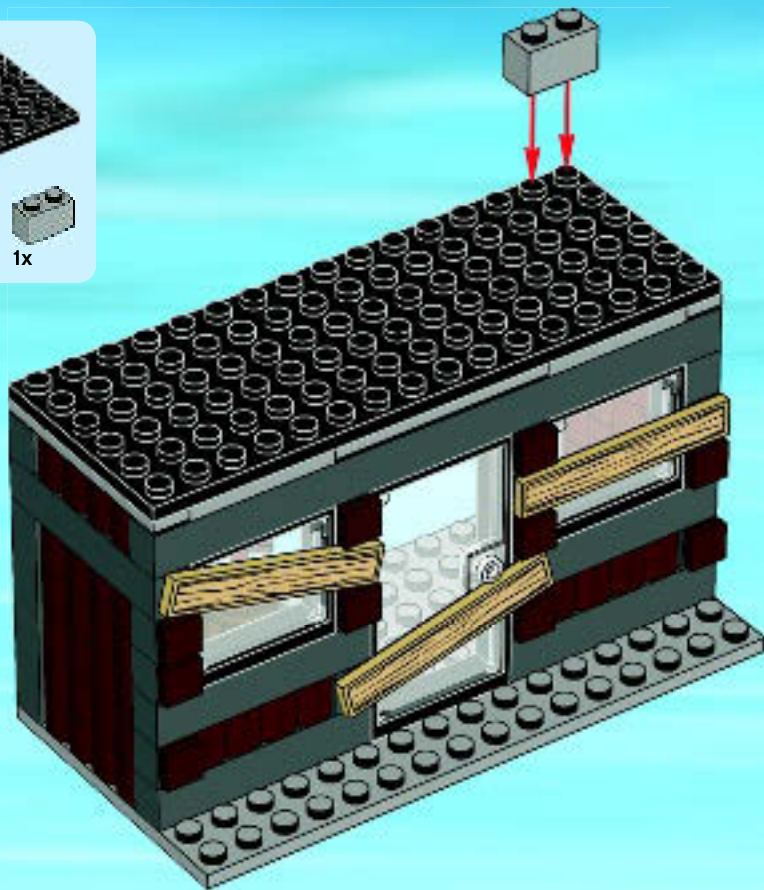

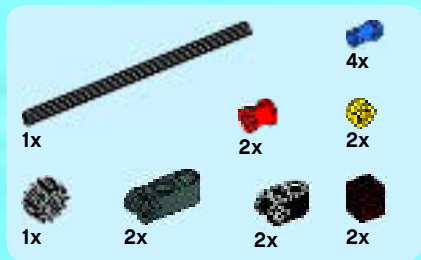

# 23

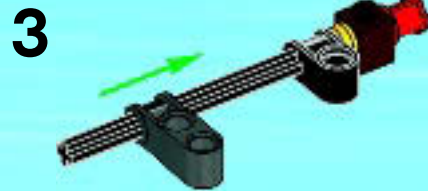
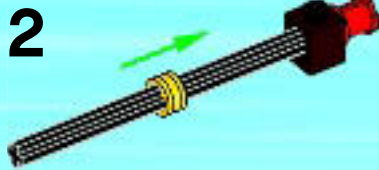
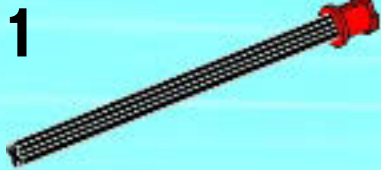



4

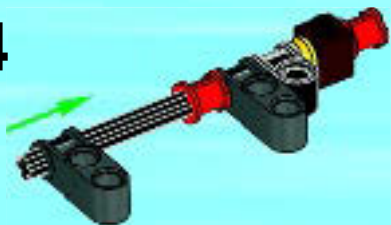

5



6

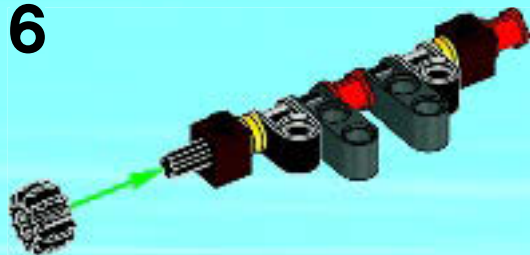

7

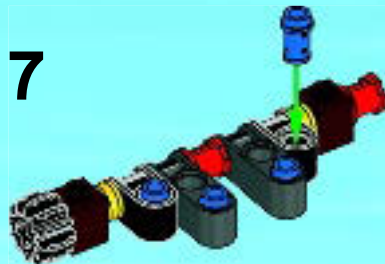

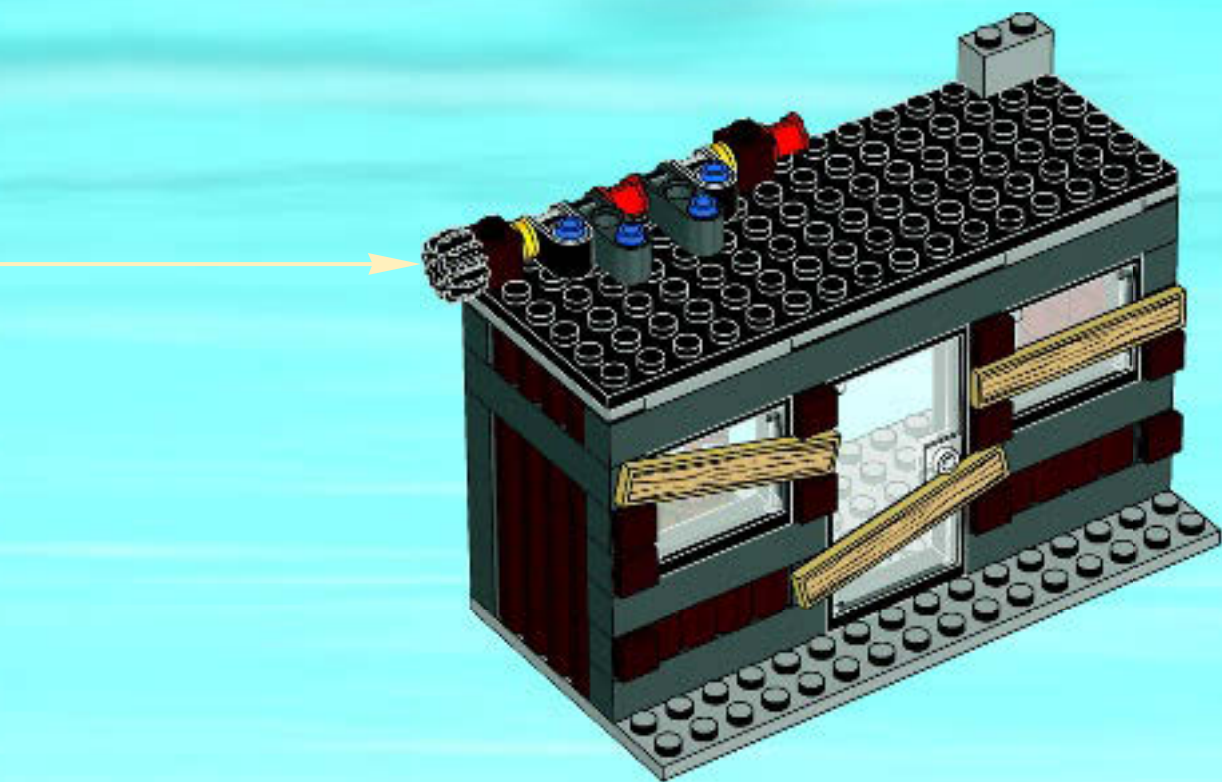

24

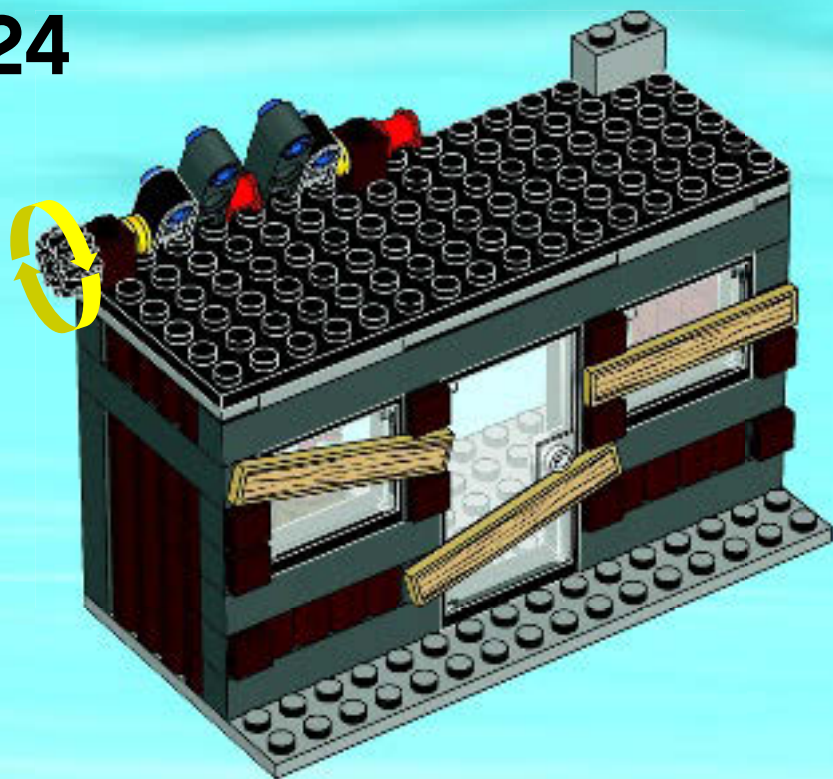



1x



2x

25

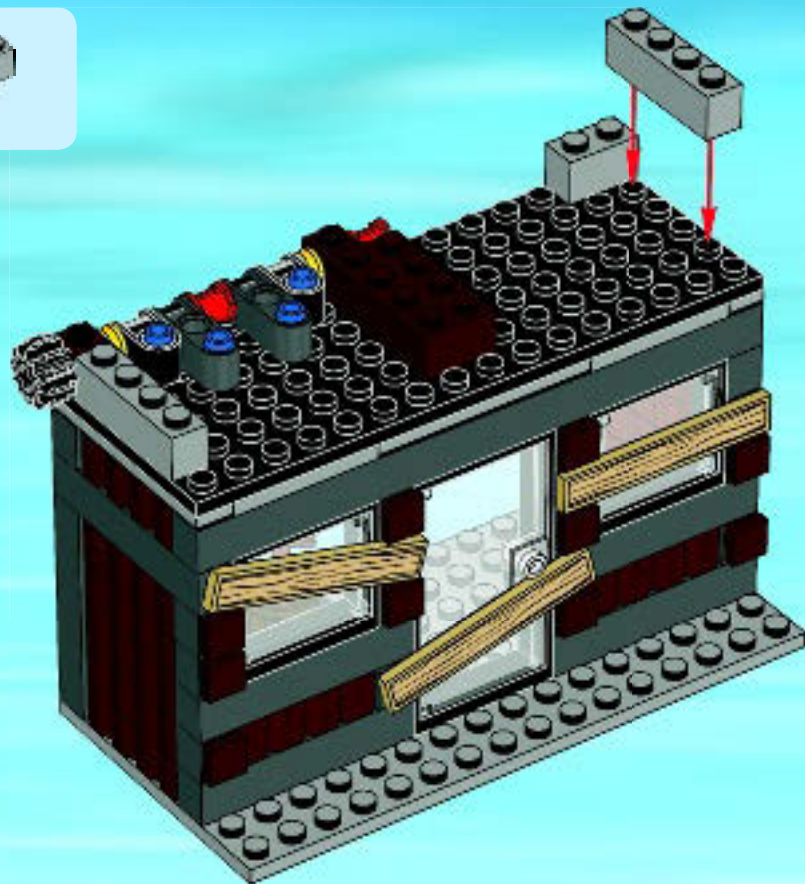

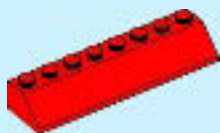

2x

26

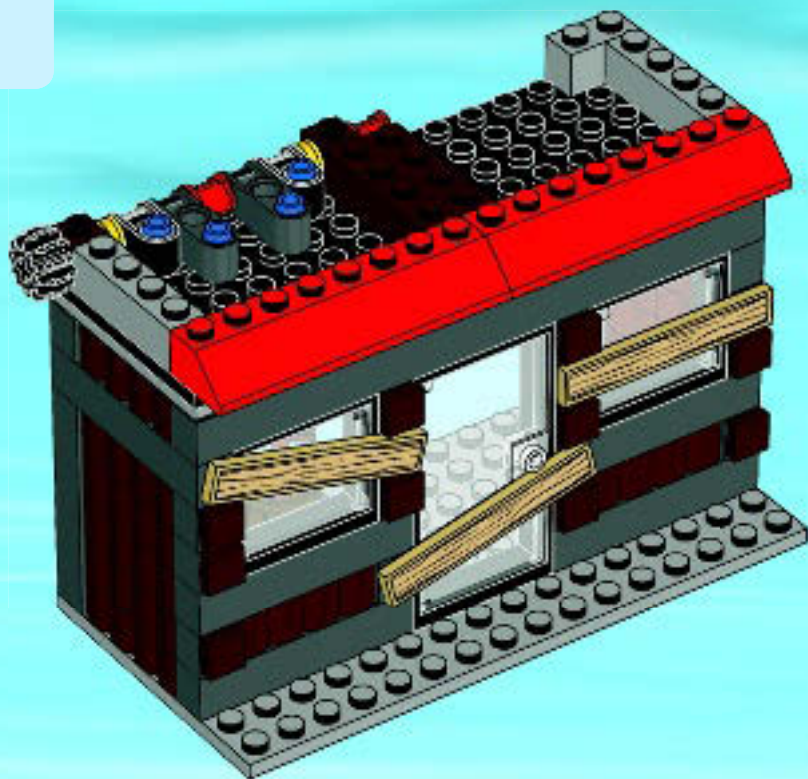



2x

27

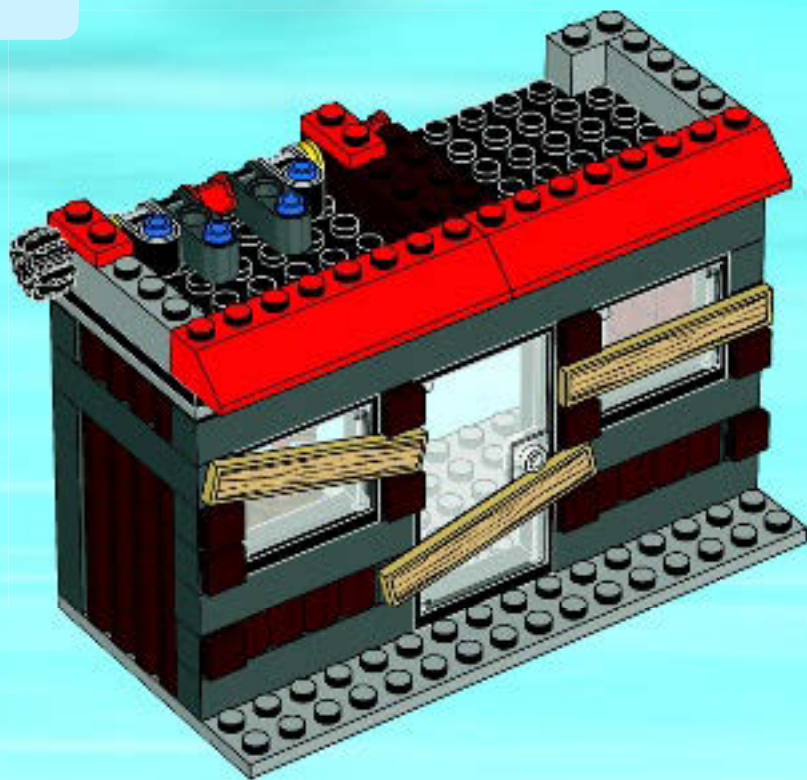



1x



1x



1x

# 28

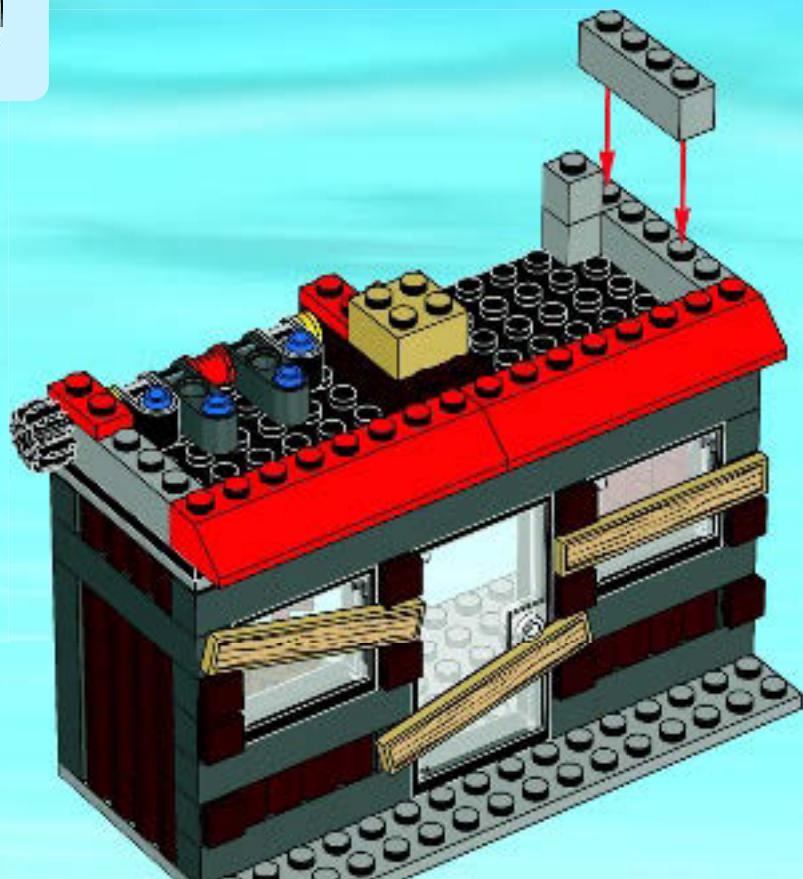





1x



1x

29

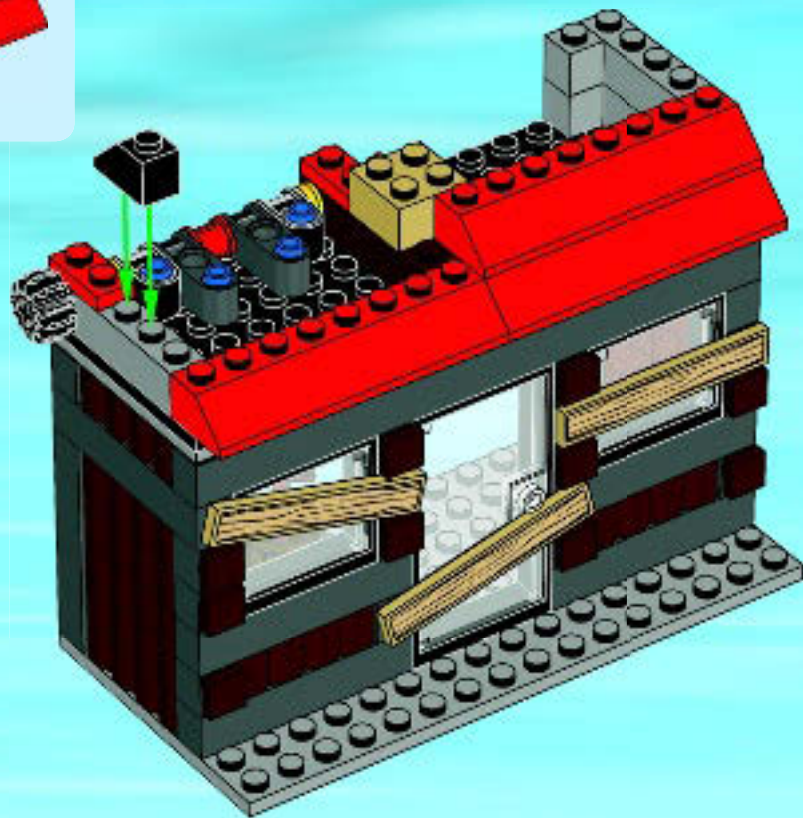



1x



2x

30

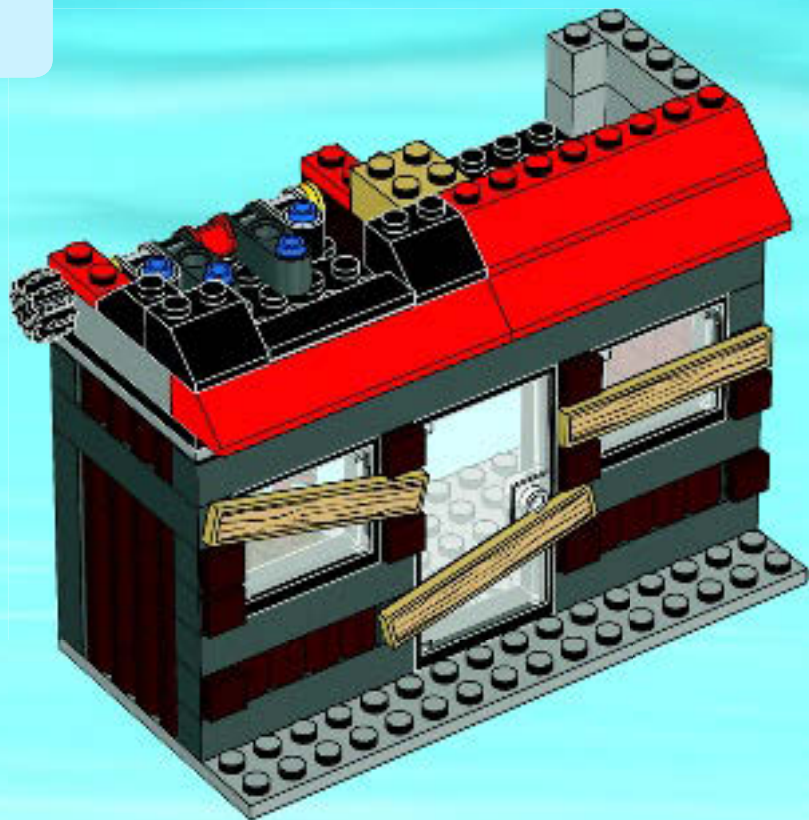



2x



1x

# 31

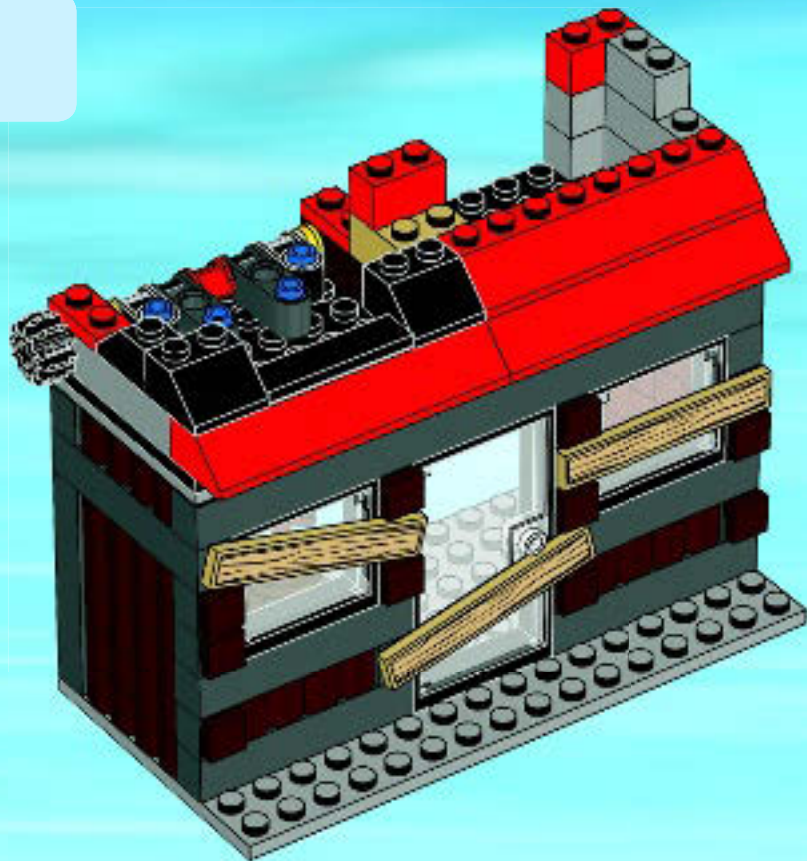



1x



1x

32

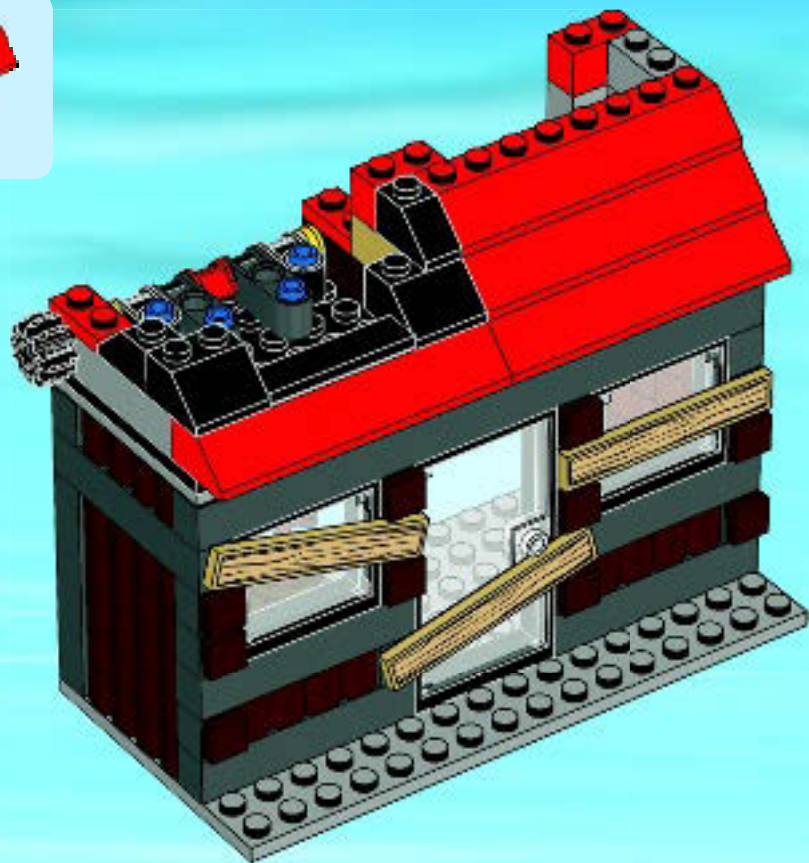



2x

33

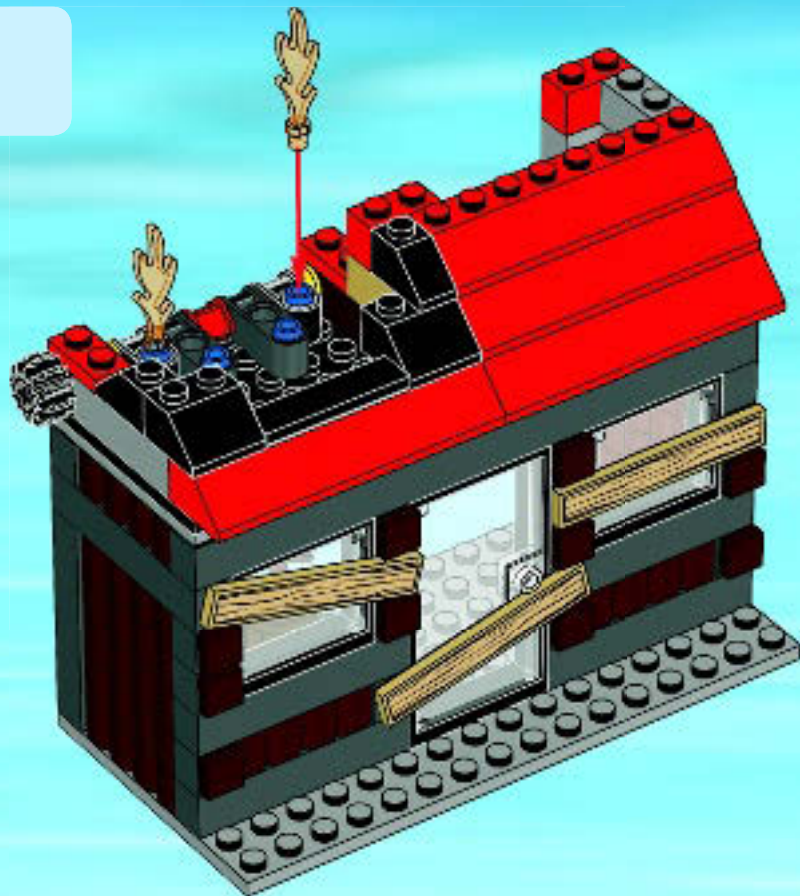



2x

34

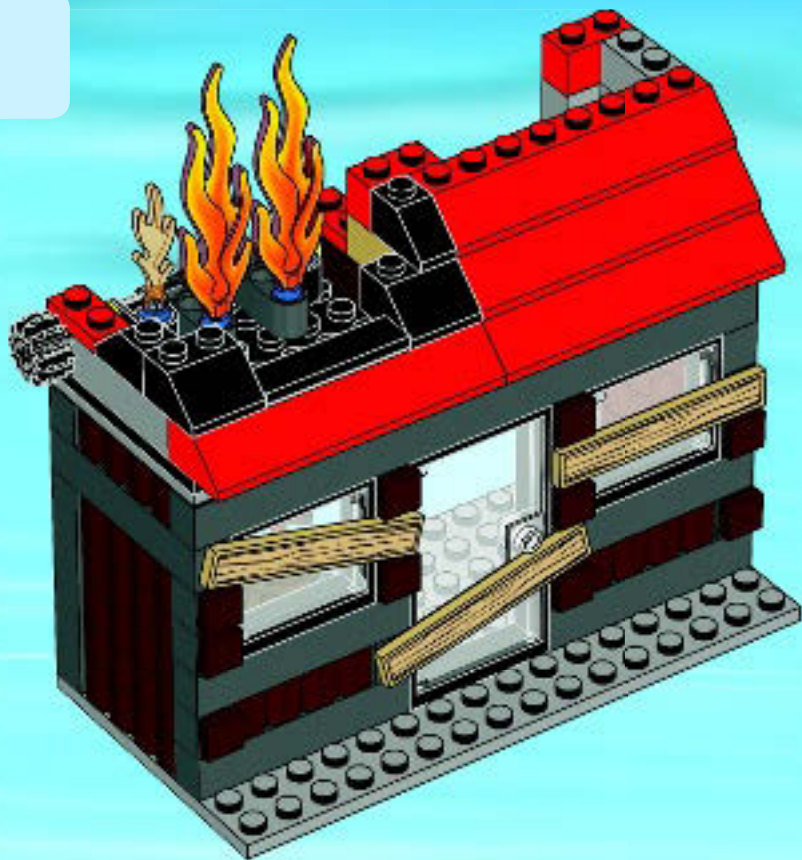

38



1x



1x

# 35

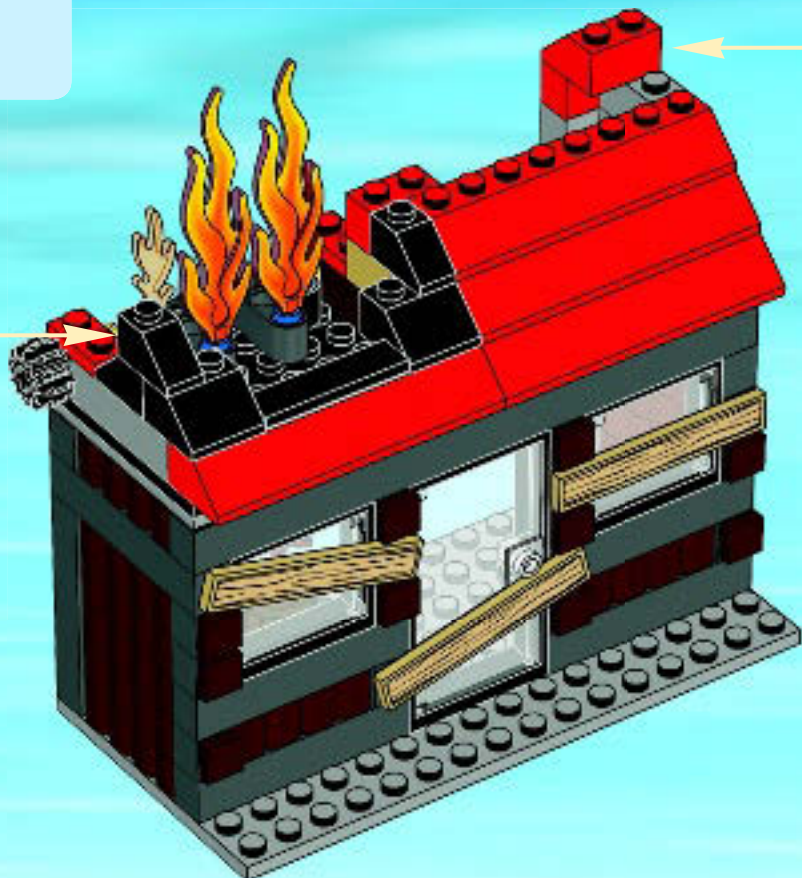



1x



1x

36

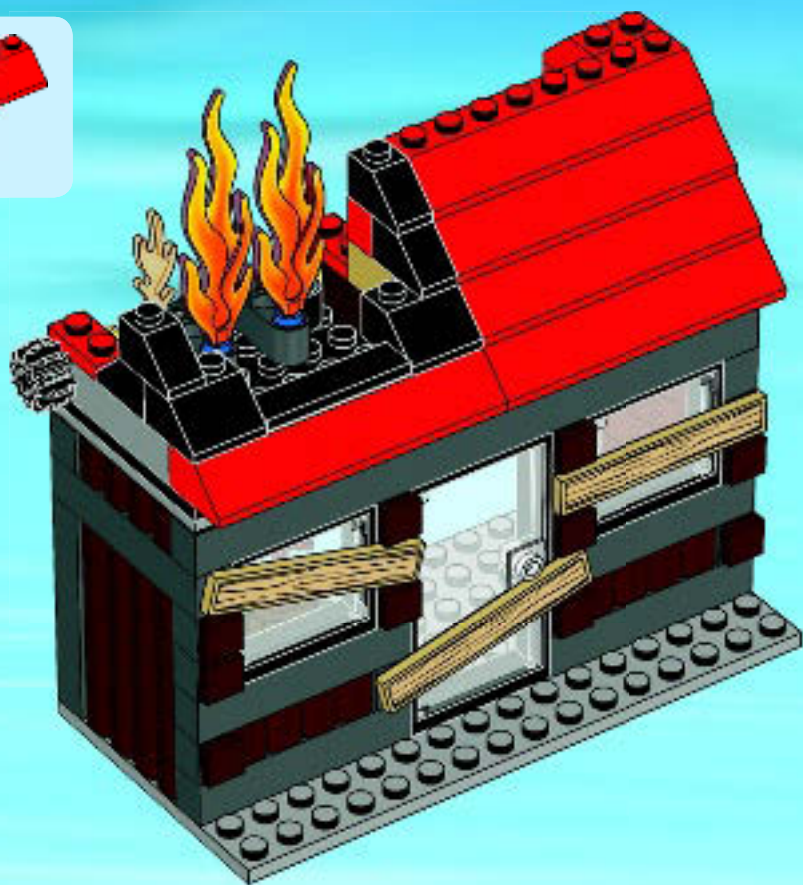





1x



1x

37

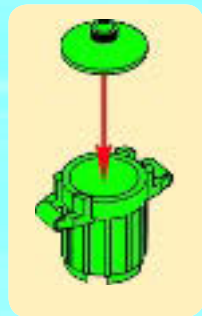
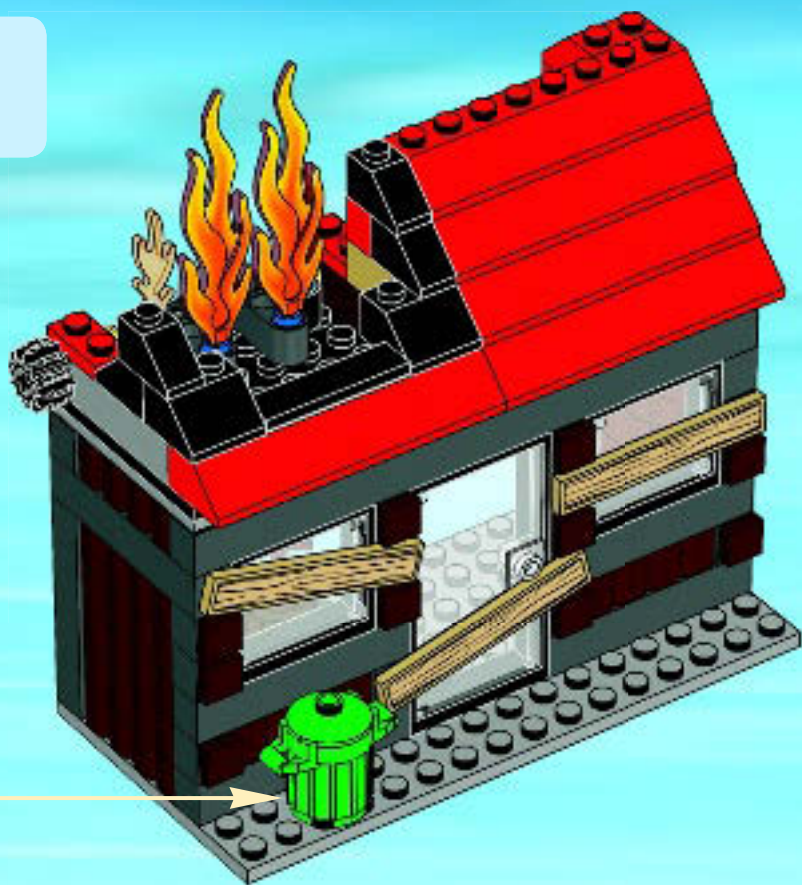



1x

38

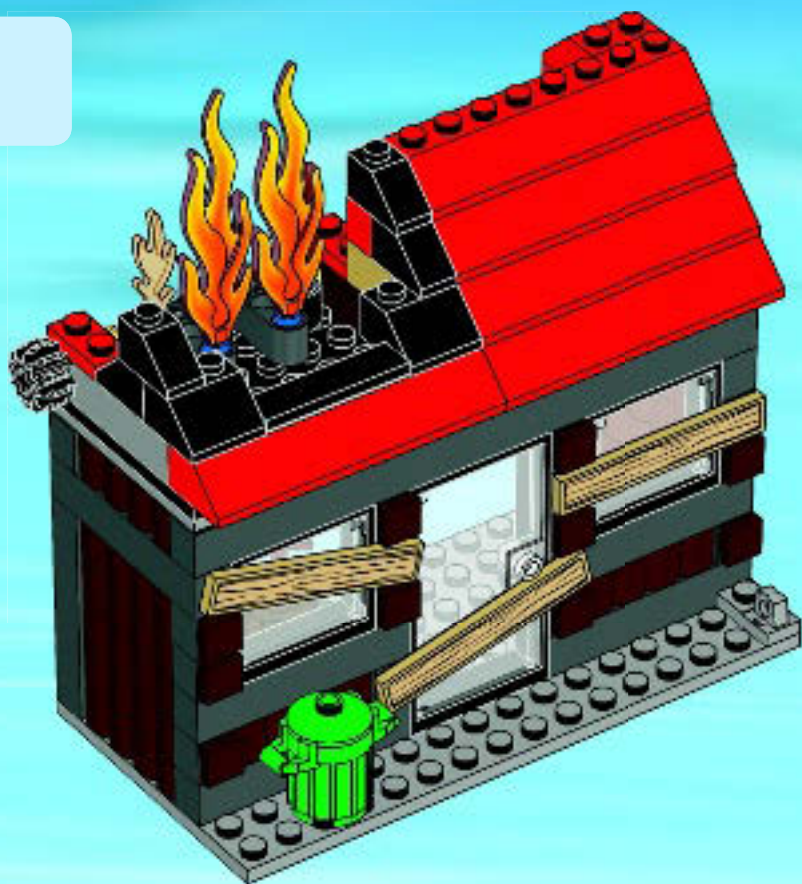

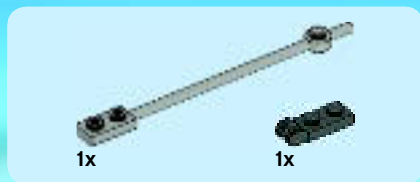

39

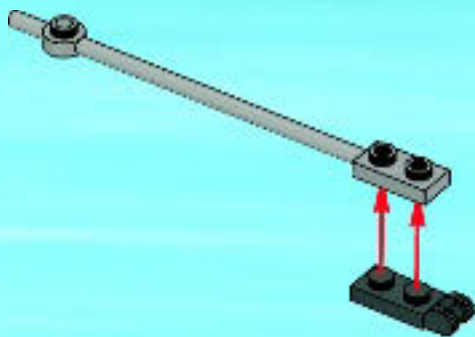

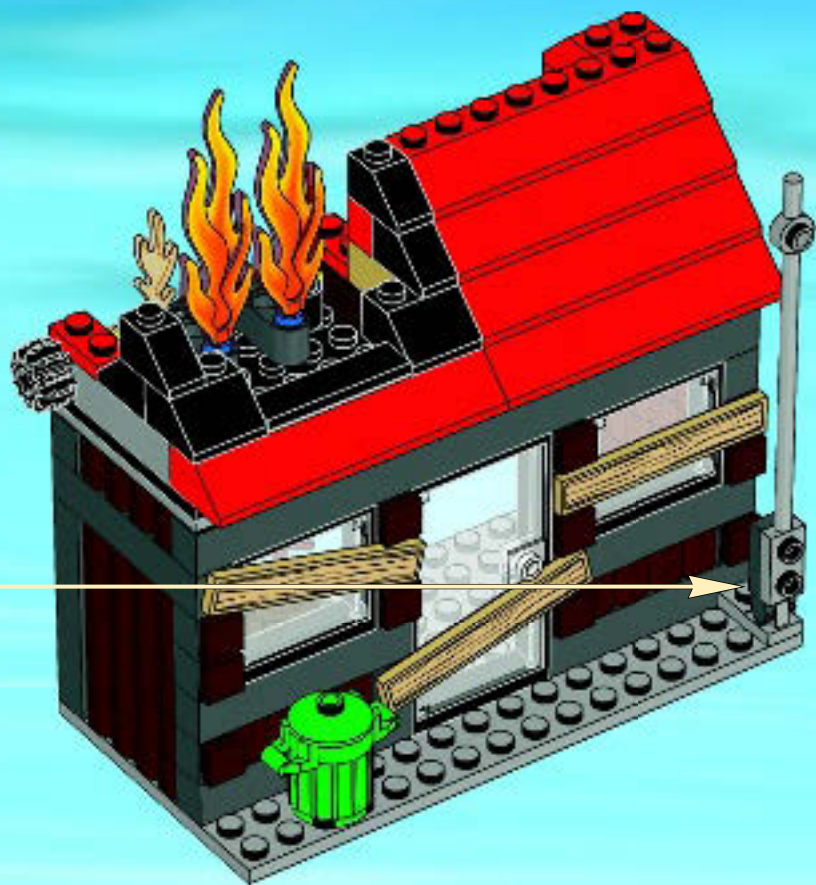

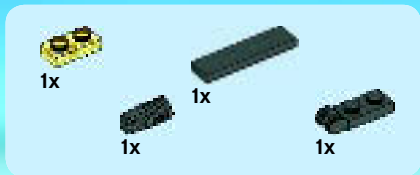

# 40

1

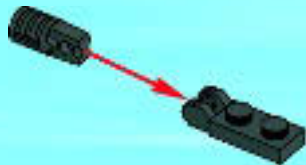

2

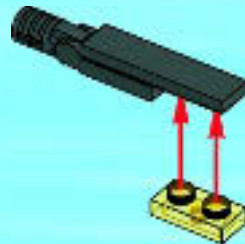

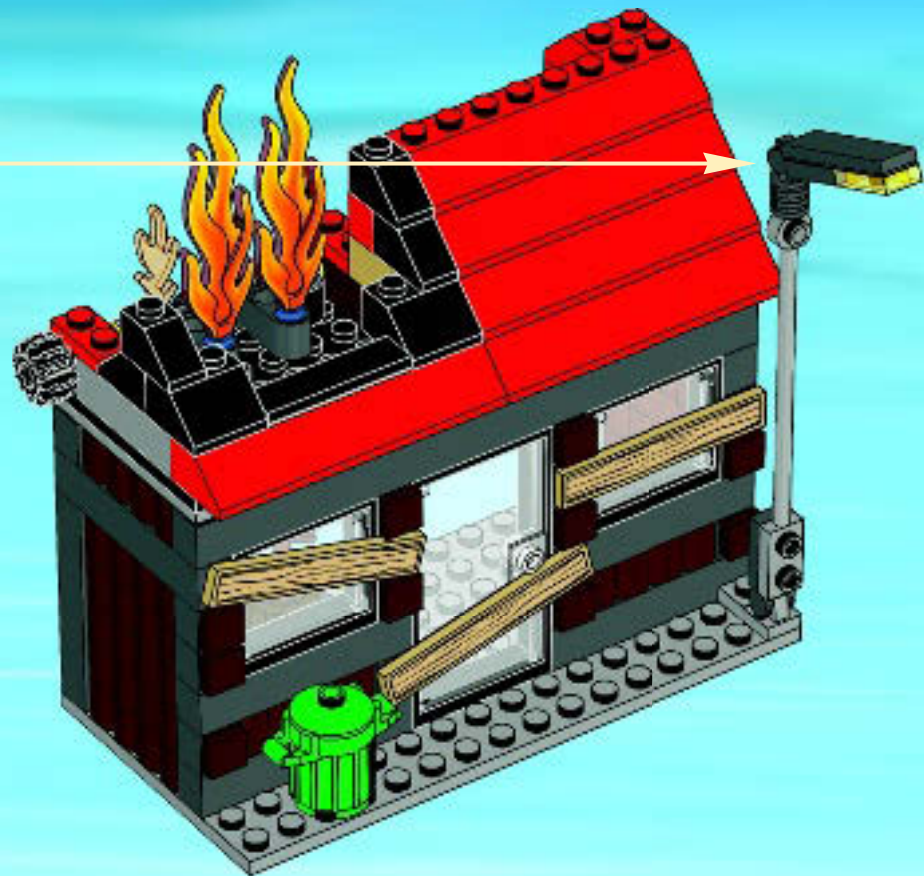



CITY



60008



60007



60006



[www.LEGOclub.com/Max](http://www.LEGOclub.com/Max)

**LEGO club**™

**FREE\*! GRATIS! GRATUIT!**

\*Paid subscription in Australia and New Zealand.  
\*Abonnement payant en Australie et Nouvelle-Zélande.

©2013 The LEGO Group.







# CREATOR

31002



31003



31004



31005



31006





4x  
4170457



1x  
6018585

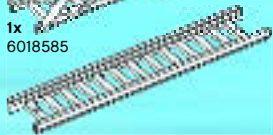

1x  
420701



2x  
4514842



2x  
4560929



3x  
379501



1x  
366601



2x  
4597131

**50**



2x  
4504369



2x  
4249112



1x  
4243812



2x  
4227155



5x  
371021



1x  
4597912



2x  
4263821



1x  
4259903



2x  
4565432

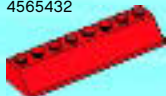

5x  
4550322



2x  
300721



8x  
366521



1x  
303921



2x  
428621



6x  
300421



11x  
302321



2x  
4581308



4x  
4113205



1x  
486521



1x  
4537986



1x  
4288209



2x  
243223



1x  
9566



4x  
4143005



2x  
4206482



1x  
4114306

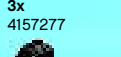

3x  
4157277



4x  
4121966



2x  
303926



2x  
244426

1x  
243126



2x  
4530589



3x  
6018684



3x  
6018492



1x  
383526



4x  
4568644



1x  
258426



2x  
4535739

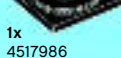

1x  
4517986



2x  
4173668



1x  
4177431



1x  
302726



1x  
373726



5x  
302026



1x  
4567908



1x  
4626650



1x  
4521504



1x  
4521504



2x  
4552033



1x  
4535834



1x  
4594685



1x  
4155537



1x  
4287016



5x  
4260426



6x  
4646861



**Customer Service**  
**Kundenservice**  
**Service Consommateurs**  
**Servicio Al Consumidor**  
**LEGO.com/service or dial**



: 00800 5346 5555  
 : 1-800-422-5346



# WIN!

Go to [www.LEGOsurvey.com/product](http://www.LEGOsurvey.com/product) to fill out a survey for a chance to win a cool LEGO® Product.

No purchase necessary.

Open to all residents where not prohibited.



## [www.LEGOsurvey.com/product](http://www.LEGOsurvey.com/product)

### GEWINNE!

Nimm an der Umfrage auf [www.LEGOsurvey.com/product](http://www.LEGOsurvey.com/product) teil und hab die Chance ein cooles LEGO® Produkt zu gewinnen!

Die Teilnahme am Gewinnspiel führt zu keinerlei Kaufverpflichtungen. Teilnahme in allen nicht ausgeschlossenen Ländern möglich.

### WIN!

Ga naar [www.LEGOsurvey.com/product](http://www.LEGOsurvey.com/product), vul een enquêteformulier in en maak kans op een cool LEGO® product.

Geen aankoopverplichting. Iedereen mag deelnemen, uitgezonderd ingezetenden van landen waar een enquêteverbod geldt.

### GAGNE!

Visite [www.LEGOsurvey.com/product](http://www.LEGOsurvey.com/product) pour répondre à un questionnaire et avoir une chance de gagner un produit LEGO® très cool!

Aucune obligation d'achat. Ouvert à tous les résidents des pays autorisés.

### 当てよう!

[www.LEGOsurvey.com/product](http://www.LEGOsurvey.com/product) にアクセスして、アンケートにご記入ください。当選者にはレゴ®製品を差し上げます。

お買い上げの必要はありません。禁止されていない限り、すべての皆様にご利用いただけます。



LEGO.com

6051356

LEGO and the LEGO logo are trademarks of the/son des marques de commerce de/son marcas registradas de LEGO Group. ©2013 The LEGO Group.