



# STAR WARS

75098



# About the LEGO® Star Wars™ Design Team

LEGO® Star Wars started in 1999 and we have made new models for the product line every year since then. The LEGO Star Wars design team consists of eight model designers and four graphic designers. The team is a mix of brand-new designers with fresh ideas, and experienced LEGO Star Wars designers with many models under their belts.

This is an ideal team for creating new, innovative LEGO Star Wars models, as well as revising and improving previous LEGO versions of classic and iconic Star Wars ships. The focus of our main LEGO Star Wars product line is to make cool, fun and inspiring LEGO Star Wars models for kids.

For LEGO Direct we have the opportunity to make even bigger, more challenging, models with special attention to accuracy and details. These models are fun and exciting to develop, but also a huge challenge! We always do our very best, and hope you will enjoy the building experience.

Happy building!



Jens Kronvold Frederiksen  
Design Director  
LEGO® Star Wars





# About the Battle on Hoth



© & ™ Lucasfilm Ltd.

On the secluded ice world of Hoth, the Rebel Alliance had stationed a defense-heavy, anti-infantry base to act as Alliance headquarters. The planet Hoth was protected by an asteroid belt, distance, and frigid temperatures, making it the perfect location for the covert hangar known as Echo Base. Despite these defenses, Darth Vader's Death Squadron located Echo Base, and after failing in an attempted surprise attack on the base, launched a full-scale ground assault with an army of Snowtroopers and AT-ATs.

After destroying the power generators, decimating the ranks of Alliance soldiers, and breaking through Echo Base's shields, Imperial Snowtroopers infiltrated the base and began close combat. As staff and support evacuated the base, the remaining Alliance soldiers continued to defend Echo Base, buying enough time for heroes Han Solo, Leia Organa, and Luke Skywalker to escape.

Before its destruction, Echo Base served as the Alliance headquarters, and was well protected from outside threats. Featuring a large Tauntaun Stable, a Snowspeeder Hangar, and a Medical Bay, it was equipped with the latest technology and was a tactical asset as well as a haven for enemies of the Galactic Empire. Constructed by the Alliance Corps of Engineers, Echo Base was an engineering feat, created by utilizing the ice and snow natural to Hoth as intrinsic parts of the base construction.

Despite their eventual defeat, the Alliance soldiers of Echo Base dealt heavy losses to the Galactic Empire, and frustrated Darth Vader in his attempts to capture Luke Skywalker.





# Battle Facts

Conflict.....Galactic Civil War  
 Date.....3ABY  
 Location.....Echo Base, Hoth  
 Outcome.....Imperial Victory  
 Combatants.....Galactic Empire; Rebel Alliance

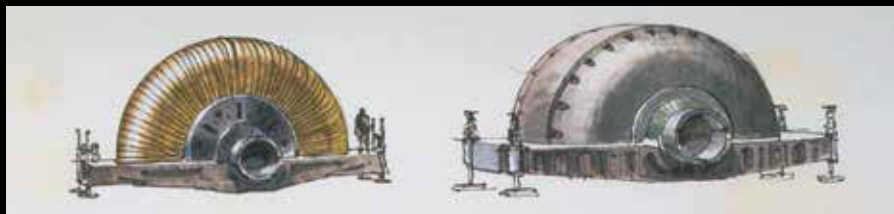

© & ™ Lucasfilm Ltd.



Visual Effects Artist © & ™ Lucasfilm Ltd.

# Echo Base Specifications

Location.....Hoth  
 Constructed.....2ABY  
 Destroyed.....3ABY  
 Built By.....Alliance Corps of Engineers  
 Armament.....SFS L-s1 laser cannons

# Meet the Model Designer

Hans Burkhard Schlömer

**Q: When did you become a LEGO® Star Wars™ model designer?**

**A:** The Ultimate Hoth battle is my third *Star Wars* set. Before *Star Wars* I worked on a different LEGO® theme for three years. My LEGO career started with designing 3-D models for a LEGO computer game in 2008. I guess three is my lucky number!

**Q: What did you do to prepare yourself for designing the Hoth Battle set?**

**A:** Designers' desks are notoriously messy, with piles of LEGO elements of all kinds and colors and partly assembled models everywhere. I knew I was going to need space. It is very important to clear the desk first—especially when starting up a new set of this size.

**Q: How was designing the Hoth Battle different from your work on other models?**

**A:** In terms of number of elements, the size of the Hoth battle is close to that of the UCS *Slave I* I designed earlier. But whereas the *Slave I* is one big model, the Hoth set consists of many smaller models, some of them with functions. It was more like designing several regular retail sets at once.



Hans Burkhard Schlömer



**Q: The Battle of Hoth is one of the most famous battles in the *Star Wars*™ universe, and was a major victory for the Galactic Empire at the time. How does this determine which vehicles or minifigures would be included in the set?**

**A:** The whole LEGO® *Star Wars* design team first built an early sketch model of the set. We focused mainly on the Rebel base and built items on our wish list—models we had never done before like the Ion cannon, the power generator, or the smaller Rebel vehicle. Many other smaller LEGO Hoth sets have been released over the previous years, but they will be long gone by the time this set is coming out. Here you get the entire battle in one set!

A new character I really wanted to have in this set is Toryn Farr, the female combat operations officer who orders the Ion cannon to open fire. She knocks out a whole Star Destroyer so she just had to be in this set! Also on my wish list was K-3PO, the white Protocol Droid, a returning character who only appeared in one other set eight years ago.



© & ™ Lucasfilm Ltd.

**Q: Environmental elements such as the jagged edge of the snow drifts bring the set to life in a realistic way. How do you consider the environment with regards to your set design when creating sets for LEGO® *Star Wars*?**

**A:** For a designer it is important to be efficient when creating environment details and to focus on the essentials, like functions and play features. Having massive snow drifts would certainly look impressive, but wouldn't add a lot to the set in terms of play value. While there do exist fancy building techniques to create snowscapes with LEGO bricks (for example, building sideways with slope bricks or using transparent elements), I kept that part rather basic to speed up the building experience, so the customer can focus on the fun items, like the Rebel equipment. Fortunately, snow isn't hard to make with LEGO bricks!

**Q: Hoth is an icy, snowy planet, and the Hoth Battle set is built using mostly white bricks. When working with so many LEGO bricks that are the same color, how do you make specific sections of the set stand out?**

**A:** Maybe I should mention that the surfaces of our designers' desks are also white, so tell me about it! We always put off-color elements in LEGO sets to heighten visibility of bricks and aid in the building process. Sometimes the bricks are VERY off-color. Think of me when you find those dark-blue bricks hidden inside the power generator!

But when all is said and done, snow still has to be white, and Hoth is one big snowball. I did experiment with mixing in elements in royal light blue as a different shade of ice, but that didn't look right in the trench or on the gate. It worked better inside the Wampa cave, which is more ice than snow anyway.

**Q: What are some of the techniques you used when designing and building the set to ensure it would be sturdy?**

**A:** Model stability is very important, and often brick clutch power just isn't enough to ensure sturdiness. One important technique is vertical locking: those long white LEGO® technic beams on the rear of the base entrance make sure the layers of bricks don't come apart easily and also provide safe docking points for the smaller base modules.

**Q: The Battle of Hoth is a huge battle; with so much material available, how did you determine which elements from the battle would be included in the design of this set?**

**A:** There are some essentials that just have to be there, like the base entrance. Or a snowspeeder, the Rebel Alliance's main fighter on Hoth. Since Luke's snowspeeder (with dark gray marking) just came out again last year, we included the regular rogue squadron version in this set—which got orange markings.

We also wanted to bring back the Wampa ice monster with its lair, and add interior to the base. Focusing on the Rebel base, the Imperial presence in this set is quite light. A new AT-AT just came out last year, so you can still replay the whole battle in style—and the Imperial Snowtroopers got a brand-new E-web blaster that actually shoots!

**Q: Is there a specific feature of the Hoth Battle set that you like best?**

**A:** We took some liberty when creating the extendable lookout. It's a detail taken from the Rebel base on Yavin 4 from the previous movie, so we just assumed every Rebel base had to have lookouts and we just don't see them in *The Empire Strikes Back*. The Rebels always need to watch out for approaching Imperials, right? Even though it has to be freezing cold up there!



© & ™ Lucasfilm Ltd.

**Q: There are many details in this set, especially in the back, like sliding blast doors, flick missile turrets, and an exploding power generator. How do you work in functionality when designing a set? Is it difficult to design a set with moving parts?**

**A:** Moving parts can definitely make my day ... interesting! Building a set of sliding doors usually is very easy—but not so with a LEGO set. We have to allow room for building mistakes and rough handling of the model. Trying to foresee everything that could go wrong and prevent it from happening is not an easy task. After all, it won't do to have the blast doors stuck half-closed just because some plates have not been pressed together strongly enough during the build. Darth Vader would laugh himself silly—WAY too easy!



# Meet the Graphic Designer

Paul Constantin Turcanu

**Q: As a graphic designer for the LEGO Group, what are your main duties?**

**A:** My main role is designing exciting graphics for both minifigures and stickers.

**Q: How long have you worked on LEGO® Star Wars™?**

**A:** I started working for the LEGO Group two years ago and I was assigned to the *Star Wars* project from the beginning.

**Q: What do you use to begin designing the decorations for LEGO Star Wars minifigures?**

**A:** I usually start either by re-watching scenes related to the figures, or studying official references. I do like to start sketching on paper and when I am happy with the result, I trace it digitally.

**Q: Minifigures are very small. What are some challenges in creating designs that are both detailed, but easy to understand?**

**A:** Keeping it simple is the key. Of course, when we have a highly detailed reference we try to translate it in LEGO® form by guiding the eye to the most iconic parts that make it easily recognizable.



Paul Constantin Turcanu

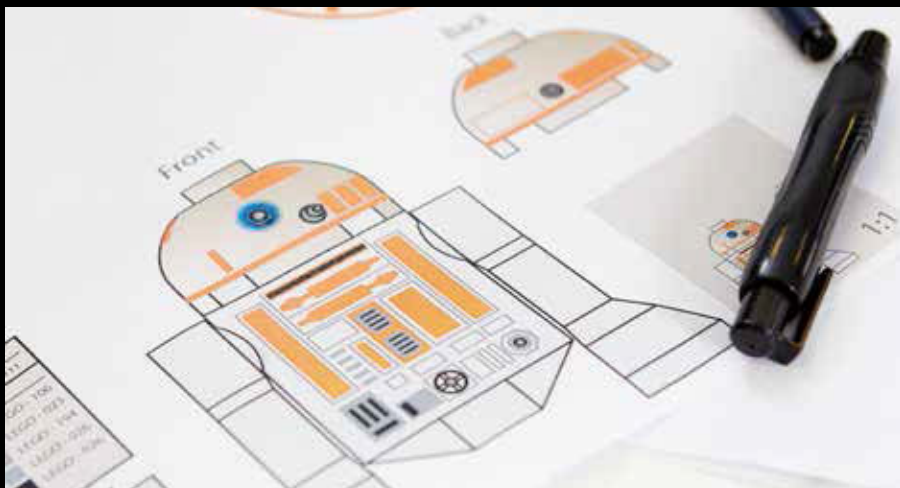

© & ™ Lucasfilm Ltd.

**Q: What do you use as reference material for designing the minifigure decorations? Film stills? Licensed art?**

**A:** On the new *Star Wars* productions the official references are very good. On the first three movies, sometimes it can be challenging even with the official pictures. Re-watching scenes or playing related videogames usually helps a lot.

**Q: Many characters who appear in this set do not have large roles in the *Star Wars*™ movies. How do you bring their characters to life in this set without having much film reference?**

**A:** Personally, I am a really big fan of these side characters, and I like the challenge of making a cool minifigure out of something that maybe is not that iconic. The nice part is that when I get to do a bit of research I realise how all of them have side stories, their own history—it is fantastic to dig deeper into the vast universe that is *Star Wars*. This really helps in giving a nice feel to the character: brave, cowardly, determined, or just adventurous.

**Q: Was there a minifigure that you enjoyed designing the most?**

**A:** I really enjoyed working on R3-A2, maybe because it's the first time that he has appeared in a LEGO® product. You can barely see him in the movie, but I am sure the fans out there will highly appreciate it. Also, his top details being printed on a transparent element adds a lot to the overall look.

**Q: In addition to regular human-shaped minifigures, there are many aliens, droids, and strange creatures that populate the Hoth Battle set. What are some differences in designing decorations for this large range of figures?**

**A:** We try to keep the decorations as iconic and as efficient as possible. Even if it's animals or alien species, we try to stay as much as possible in our style guide and keep the same graphic characteristics as our regular minifigures.



© & ™ Lucasfilm Ltd.



# À propos de l'équipe de design LEGO® Star Wars™

LEGO® Star Wars a commencé en 1999 et nous avons conçu chaque année depuis de nouveaux modèles pour cette gamme de produits. L'équipe de design LEGO Star Wars est composée de huit créateurs de modèles et de quatre graphistes. Cette équipe est un mélange de nouveaux designers avec des idées originales et de designers LEGO Star Wars expérimentés ayant créé de nombreux modèles.

Il s'agit de l'équipe idéale pour créer de nouveaux modèles LEGO Star Wars innovants et pour améliorer les versions LEGO antérieures des célèbres vaisseaux classiques Star Wars. L'objectif de notre gamme principale de produits LEGO Star Wars est de créer des modèles LEGO Star Wars cool, amusants et stimulants pour les enfants.

Pour LEGO Direct, nous avons la possibilité de créer des modèles encore plus grands et plus complexes, en prêtant une attention particulière à la précision et aux détails. Ces modèles sont amusants et fascinants à concevoir, mais ils constituent aussi un énorme défi ! Nous faisons toujours de notre mieux et nous espérons que tu apprécieras l'expérience de construction.

Bonne construction !



Jens Kronvold Frederiksen  
Directeur du design  
LEGO® Star Wars



# À propos de la bataille de Hoth



© & ™ Lucasfilm Ltd.

Dans le monde glacé et isolé de Hoth, l'Alliance rebelle avait installé une base anti-infanterie avec de puissantes défenses pour servir de quartier général à l'Alliance. La planète Hoth était protégée par une ceinture d'astéroïdes, la distance et des températures glaciales, ce qui en faisait le lieu idéal pour le hangar camouflé connu sous le nom de Base Echo. Malgré ces défenses, l'Escadron de la mort de Darth Vader localisa la Base Echo et après avoir échoué lors d'une attaque surprise de la base, il lança une attaque terrestre à grande échelle avec une armée de Snowtroopers et d'AT-AT.

Après avoir détruit les générateurs de puissance, décimé les rangs des soldats de l'Alliance et franchi les boucliers de la Base Echo, les Snowtroopers impériaux ont infiltré la base et commencé un combat rapproché. Alors que le personnel évacuait la base, les soldats de l'Alliance qui restaient continuèrent à défendre la Base Echo, gagnant assez de temps pour que les héros Yan Solo, Leia Organa et Luke Skywalker s'échappent.



Avant sa destruction, la Base Echo servait de quartier général de l'Alliance et était bien protégée contre les menaces extérieures. Comprenant une grande écurie pour tauntauns, un hangar pour Snowspeeder et un poste médical, elle était équipée des technologies les plus modernes et était un atout technique ainsi qu'un refuge pour les ennemis de l'Empire galactique. Construite par le Corps d'ingénieurs de l'Alliance, la Base Echo était un chef-d'œuvre d'ingénierie, créée en utilisant la glace et la neige de Hoth comme éléments intrinsèques.

Malgré leur défaite finale, les soldats de l'Alliance de la Base Echo ont infligé de lourdes pertes à l'Empire galactique et gêné Darth Vader dans ses tentatives pour capturer Luke Skywalker.



# Informations sur la bataille

Conflit..... Guerre civile galactique  
 Date..... 3 ap. BY  
 Lieu..... Base Echo, Hoth  
 Résultat..... Victoire impériale  
 Combattants..... Empire galactique; Alliance rebelle

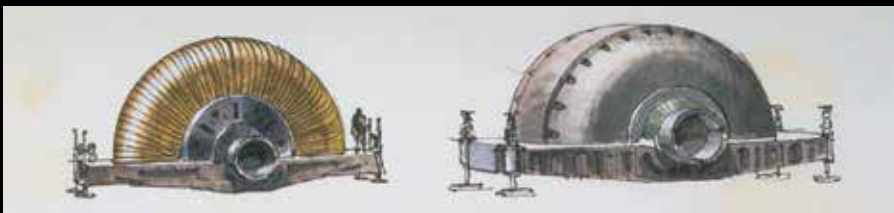

© & ™ Lucasfilm Ltd.

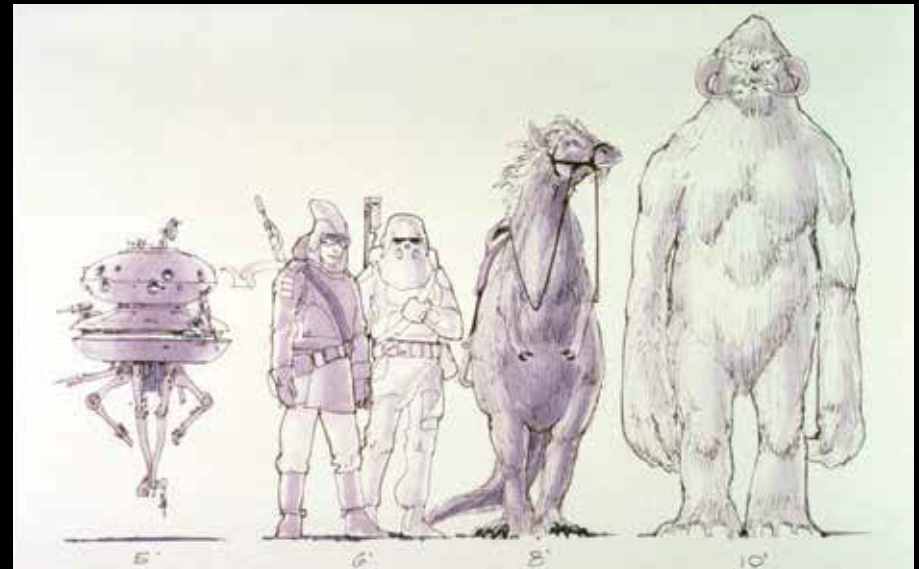

Créatrice des effets spéciaux © & ™ Lucasfilm Ltd.

# Caractéristiques de la Base Echo

Lieu..... Hoth  
 Construction..... 2 ap. BY  
 Destruction..... 3 ap. BY  
 Construite par..... Le Corps d'ingénieurs de l'Alliance  
 Armement..... Canons laser SFS L-s1





# Rencontre le designer du modèle

Hans Burkhard Schlömer

**Q : Depuis combien de temps es-tu concepteur de modèles LEGO® Star Wars™ ?**

**R :** La bataille de Hoth suprême est mon troisième ensemble *Star Wars*. Avant *Star Wars*, j'ai travaillé sur un thème LEGO® différent pendant trois ans. Ma carrière LEGO a commencé en créant des modèles 3D pour un jeu d'ordinateur LEGO en 2008. Je pense que trois est mon chiffre porte-bonheur !

**Q : Qu'as-tu fait pour te préparer à créer l'ensemble de la bataille de Hoth ?**

**R :** Les bureaux des designers sont généralement très en désordre, avec des piles d'éléments LEGO de toutes les sortes et de toutes les couleurs et des modèles partiellement assemblés partout. Je savais que j'allais avoir besoin d'espace. Il est très important de dégager le bureau en premier, surtout quand on commence un nouvel ensemble de cette taille.

**Q : En quoi la conception de la bataille de Hoth était-elle différente de ton travail sur d'autres modèles LEGO Star Wars ?**

**R :** En termes de nombre d'éléments, la taille de la bataille de Hoth était proche de celle de l'ensemble *Slave I* que j'avais conçu auparavant. Mais le *Slave I* est un seul grand modèle, alors que l'ensemble de Hoth est composé de nombreux modèles plus petits, dont certains avec des fonctions. C'était plutôt comme concevoir plusieurs ensembles en même temps.



Hans Burkhard Schlömer

**Q : La bataille de Hoth est l'une des plus célèbres batailles de l'univers *Star Wars*™ et fut une grande victoire pour l'Empire galactique à l'époque. Comment ceci détermine-t-il les véhicules ou les figurines à inclure dans l'ensemble ?**

**R :** Toute l'équipe de design de LEGO® *Star Wars* créa d'abord un prototype de l'ensemble. Nous nous sommes concentrés principalement sur la base rebelle et nous avons construit des articles figurant sur notre liste de souhaits, des modèles que nous n'avions jamais construits auparavant tels que le canon à ions, le générateur de puissance ou le véhicule rebelle plus petit. De nombreux ensembles de Hoth LEGO moins grands ont été lancés ces dernières années, mais ils ne seront plus offerts depuis longtemps quand cet ensemble sera mis sur le marché. Il y a toute la bataille dans un seul ensemble !

Un nouveau personnage que je voulais vraiment inclure dans cet ensemble est Toryn Farr, la femme officier de combat qui ordonne au canon à ions de tirer. Elle a détruit un Star Destroyer en entier, donc elle devait absolument être présente dans cet ensemble ! Sur ma liste de souhaits figurait aussi K-3PO, le droïde de protocole blanc, un personnage récurrent qui n'est apparu que dans un seul autre ensemble il y a huit ans.



© & ™ Lucasfilm Ltd.

**Q : Des éléments de l'environnement tels que le bord irrégulier des bancs de neige donnent un côté réaliste à l'ensemble. Comment tiens-tu compte de l'environnement dans la conception d'ensembles pour LEGO® *Star Wars* ?**

**R :** Pour un designer, il est important d'être efficace lors de la création des détails de l'environnement et de se concentrer sur l'essentiel, notamment les fonctions et les caractéristiques de jeu. Avoir d'énormes rafales de neige serait certainement très impressionnant, mais n'ajouterait pas grand-chose à l'ensemble en termes de valeur ludique. Alors qu'il existe des techniques de construction avancées pour créer des paysages enneigés avec les briques LEGO (par exemple construire de côté avec des briques en pente ou utiliser des éléments transparents), j'ai gardé cet aspect plutôt simple pour accélérer l'expérience de construction, afin que les clients puissent se concentrer sur les éléments amusants, comme l'équipement rebelle. Heureusement, la neige n'est pas difficile à construire avec les briques LEGO !

**Q : Hoth est une planète enneigée et glacée et l'ensemble de la bataille de Hoth est construit principalement en utilisant des briques blanches. En travaillant avec de si nombreuses briques LEGO de la même couleur, comment fais-tu ressortir des sections spécifiques de l'ensemble ?**

**R :** Excellente question, surtout quand on sait que les surfaces des bureaux des designers sont aussi blanches ! Nous plaçons toujours des éléments de couleurs différentes dans les ensembles LEGO pour augmenter la visibilité des briques et faciliter le processus de construction. Les briques sont parfois d'une couleur TRÈS différente. Pense à moi quand tu trouveras des briques bleu foncé cachées dans le générateur de puissance !

Mais en fin de compte, la neige doit toujours être blanche et Hoth est une grosse boule de neige. J'ai fait des expériences en ajoutant des éléments en bleu clair royal comme teinte différente de glace, mais cela ne fonctionnait pas dans la tranchée ou sur la porte. Cela fonctionnait mieux dans la grotte Wampa, qui est plus glace que neige de toute façon.



**Q : Quelles techniques as-tu utilisées lorsque tu as conçu et construit l'ensemble pour t'assurer qu'il serait solide ?**

**R :** La stabilité du modèle est très importante et souvent le pouvoir d'accroche des briques n'est pas suffisant pour assurer la solidité. Une technique importante est le blocage vertical : ces longues poutres LEGO® Technic blanches à l'arrière de l'entrée de la base font que les couches de briques ne se démontent pas facilement et fournissent des points d'attache sûrs pour les modules de la base plus petits.

**Q : La bataille de Hoth est une énorme bataille. Avec tellement de matériaux disponibles, comment as-tu déterminé quels éléments de la bataille seraient inclus dans la création de cet ensemble ?**

**R :** Il y a des éléments essentiels qui devaient tout simplement être là, comme l'entrée de la base. Ou un Snowspeeder, le vaisseau de combat principal de l'Alliance rebelle sur Hoth. Étant donné que le Snowspeeder de Luke (avec des marques gris foncé) est sorti à nouveau l'année dernière, nous avons inclus la version standard de l'escadron rebelle dans cet ensemble, avec des marques orange.

Nous avons aussi voulu ramener le monstre des glaces Wampa avec sa tanière, et ajouter un intérieur à la base. En nous concentrant sur la base rebelle, la présence impériale dans cet ensemble est assez légère. Un nouvel AT-AT est sorti l'année dernière, donc il est toujours possible de rejouer toute la bataille avec style, et les Snowtroopers impériaux ont reçu un nouveau fusil E-web qui tire vraiment !

**Q : Y a-t-il une caractéristique spécifique de l'ensemble de la bataille de Hoth que tu préfères ?**

**R :** Nous avons pris quelques libertés en créant le poste d'observation extensible. C'est un détail inspiré de la base rebelle sur Yavin 4 dans le film précédent, nous avons donc imaginé que toutes les bases rebelles avaient des postes d'observation mais que nous ne les voyons pas dans L'Empire contre-attaque. Les Rebelles doivent toujours surveiller l'approche des Impériaux, n'est-ce pas ? Même s'il doit faire très froid là-haut !



© & ™ Lucasfilm Ltd.

**Q : Il y a de nombreux détails dans cet ensemble, surtout à l'arrière, comme les portes coulissantes, les tourelles lance-missile et un générateur de puissance qui explose. Comment crées-tu la fonctionnalité lors de la conception d'un ensemble ? Est-il difficile de concevoir un ensemble avec des parties mobiles ?**

**R :** Les parties mobiles peuvent réellement rendre mes journées... intéressantes ! Construire des portes coulissantes est en général facile, mais pas dans un ensemble LEGO. Nous devons tenir compte des erreurs de construction et de la manipulation sans précaution du modèle. Essayer de prévoir tout ce qui pourrait mal se passer et l'empêcher n'est pas une tâche facile. Après tout, on ne peut pas laisser les portes coincer à moitié fermées juste parce que des plaques n'ont pas été pressées assez fort pendant la construction. Cela ferait beaucoup rire Darth Vader : BEAUCOUP trop facile !

# Rencontre le graphiste

Paul Constantin Turcanu

**Q : En tant que graphiste pour le Groupe LEGO, quelles sont tes principales tâches ?**

**R :** Mon rôle principal est de concevoir des graphiques passionnants pour les figurines et les autocollants.

**Q : Depuis combien de temps travailles-tu sur des produits LEGO® Star Wars™ ?**

**R :** J'ai commencé à travailler pour le Groupe LEGO il y a deux ans et j'ai été affecté dès mes débuts au projet *Star Wars*.

**Q : Qu'utilises-tu pour commencer à créer les décorations des figurines LEGO Star Wars ?**

**R :** Je commence généralement par regarder à nouveau les scènes liées aux figurines, ou par étudier des références officielles. J'aime commencer à dessiner sur papier et quand je suis satisfait du résultat, je le trace numériquement.

**Q : Les figurines sont très petites. Quels sont les défis que pose la conception de designs à la fois détaillés, mais faciles à comprendre ?**

**R :** Rester simple est la clé. Bien sûr, quand nous avons une référence très détaillée, nous essayons de la traduire en forme LEGO® en guidant le regard vers la partie la plus emblématique qui la rend facilement reconnaissable.



Paul Constantin Turcanu



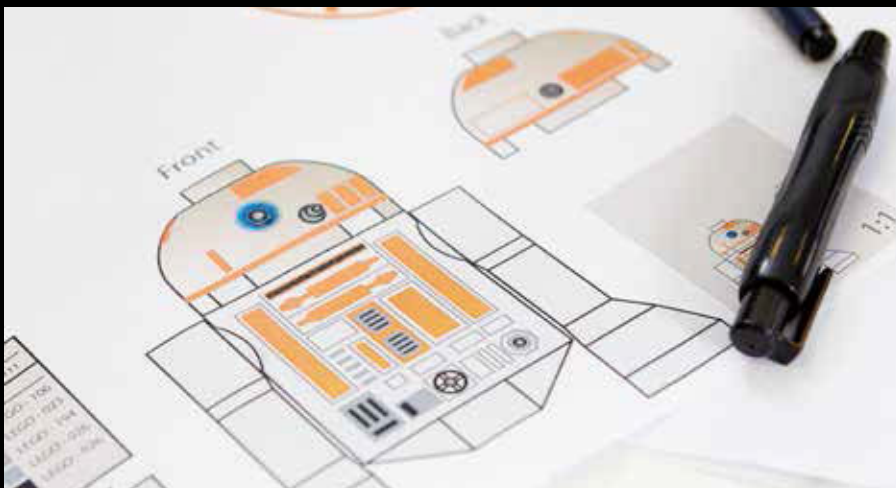

© & ™ Lucasfilm Ltd.

**Q : Qu'utilises-tu comme référence pour créer les décorations des figurines ? Des photos des films ? Des images sous licence ?**

**R :** Pour les nouvelles productions *Star Wars*, les références officielles sont très bonnes. Pour les trois premiers films, c'est parfois complexe même avec les photos officielles. Regarder à nouveau les scènes ou jouer à des jeux vidéo connexes aide généralement beaucoup.

**Q : De nombreux personnages qui apparaissent dans cet ensemble n'ont pas de grands rôles dans les films *Star Wars*™. Comment leur donnes-tu vie dans cet ensemble sans avoir beaucoup de référence des films ?**

**R :** Personnellement, j'adore ces personnages secondaires et j'aime le défi consistant à créer une figurine cool à partir de quelque chose qui n'est pas si célèbre. L'aspect agréable est que quand je fais un peu de recherche, je découvre qu'ils ont tous des histoires secondaires, leur propre histoire. Il est fantastique de creuser plus profondément dans le vaste univers qu'est *Star Wars*. Cela contribue vraiment à donner une personnalité au personnage : courageux, lâche, déterminé ou juste aventurier.

**Q : Y a-t-il une figurine que tu as préféré concevoir ?**

**R :** J'ai vraiment aimé travailler sur R3-A2, peut-être parce que c'est la première fois qu'il se trouve dans un produit LEGO®. On le voit à peine dans le film mais je suis sûr que les fans vont vraiment l'apprécier. Et les détails imprimés sur un élément transparent ajoutent beaucoup à son look général.

**Q : En plus de figurines de forme humaine, il y a beaucoup d'extraterrestres, de droïdes et d'étranges créatures qui peuplent l'ensemble de la bataille de Hoth. Quelles sont les différences dans la conception des décorations pour cette grande variété de figurines ?**

**R :** Nous essayons de garder les décorations aussi représentatives et efficaces que possible. Même s'il s'agit d'animaux ou d'espèces extraterrestres, nous essayons de respecter autant que possible notre guide de style et de conserver les mêmes caractéristiques graphiques que nos figurines habituelles.

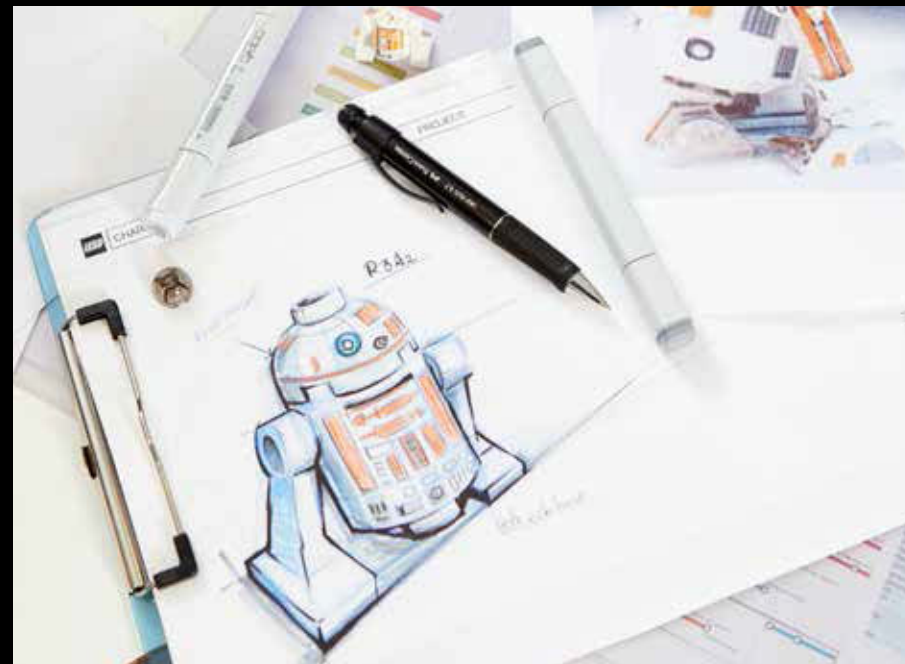

© & ™ Lucasfilm Ltd.

# Acerca del equipo de diseño de LEGO® Star Wars™

La línea LEGO® Star Wars se lanzó en 1999 y ha acogido nuevos modelos todos los años desde entonces. El equipo de diseño de LEGO Star Wars se compone de ocho diseñadores de modelos y cuatro diseñadores gráficos. El grupo combina nuevos diseñadores con ideas frescas y diseñadores con mucha experiencia en el universo LEGO Star Wars y un gran número de modelos a sus espaldas.

Es un equipo ideal para la creación de nuevos e ingeniosos modelos LEGO Star Wars y la revisión y mejora de las antiguas versiones LEGO de las clásicas y populares naves de Star Wars. El principal objetivo de la línea LEGO Star Wars es hacer llegar a los niños modelos divertidos, modernos y estimulantes basados en este universo.

Para LEGO Direct, es una magnífica oportunidad de crear modelos más grandes y complejos, prestando especial atención a la precisión y los detalles. Son modelos divertidos y emocionantes de desarrollar, ipero también muy desafiantes! Siempre nos esforzamos al máximo y esperamos que disfrutes de la experiencia de construcción.

¡Feliz construcción!



Jens Kronvold Frederiksen  
Director de diseño  
LEGO® Star Wars





# Acerca de la Batalla de Hoth



© & ™ Lucasfilm Ltd.

En el solitario mundo helado de Hoth, la Alianza Rebelde construyó una base antinfantería fuertemente defendida que servía también como cuartel general. Hoth contaba con la protección de un cinturón de asteroides, era un planeta distante y poseía gélidas temperaturas, todo lo cual lo convertía en el lugar perfecto para construir la base Echo. A pesar de tales defensas, el Escuadrón de la Muerte de Darth Vader encontró la base y, tras fallar en su intento de atacarla por sorpresa, puso en marcha un asalto por tierra a gran escala con un ejército de soldados de las nieves y transportes acorazados AT-AT.

Tras destruir los generadores de energía, diezmar las filas de la Alianza y atravesar los escudos de la base Echo, los soldados de las nieves imperiales se infiltraron en ella e iniciaron el combate cuerpo a cuerpo. Mientras el personal trataba de evacuar la base, los soldados de la Alianza siguieron defendiéndola, proporcionando a los héroes Han Solo, Leia Organa y Luke Skywalker tiempo suficiente para escapar.

Antes de su destrucción, la base Echo fue elegida como cuartel general de la Alianza por su excelente protección frente a amenazas externas. Contaba con un gran establo para Tauntauns, un hangar para aerodeslizadores de las nieves y un puesto médico, estaba equipada con la más moderna tecnología y era un verdadero activo táctico que permitía refugiarse a los enemigos del Imperio Galáctico. Construida por el Cuerpo de Ingenieros de la Alianza, la base Echo, cuyo núcleo estructural se constituía de hielo y nieve naturales de Hoth, era una verdadera proeza técnica.

Pese a la derrota final, los soldados de la Alianza destinados a la base Echo causaron graves pérdidas al Imperio Galáctico y frustraron los intentos de Darth Vader de capturar a Luke Skywalker.





# Ficha de datos de la batalla

Conflicto.....Guerra Civil Galáctica  
 Fecha.....3ABY  
 Lugar.....Base Echo (Hoth)  
 Resultado.....Victoria imperial  
 Combatientes.....Imperio Galáctico; Alianza Rebelde



Artista de efectos visuales © & ™ Lucasfilm Ltd.

## Especificaciones de la base Echo

Situación.....Hoth  
 Construcción.....2ABY  
 Destrucción.....3ABY  
 Construida por.....Cuerpo de Ingenieros de la Alianza  
 Armamento.....Cañones láser SFS L-s1

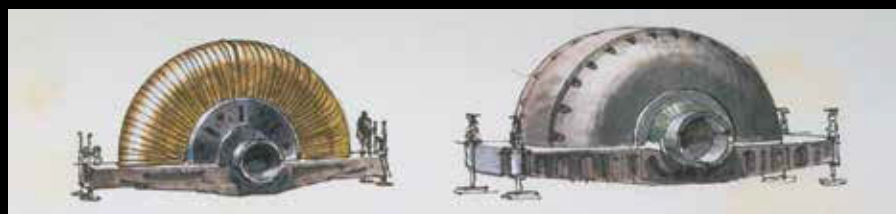

© & ™ Lucasfilm Ltd.

# Conoce al diseñador del modelo

Hans Burkhard Schlömer

**P: ¿Cuándo comenzaste a diseñar modelos para LEGO® Star Wars™?**

**R:** La Batalla de Hoth es mi tercer set *Star Wars*. Antes de formar parte del equipo de *Star Wars*, pasé tres años trabajando en otro tema LEGO®. Mi carrera en LEGO comenzó diseñando modelos en 3D para un juego de computador que LEGO publicó en 2008. ¡Creo que el tres es mi número de la suerte!

**P: ¿Cómo te preparaste para diseñar la Batalla de Hoth?**

**R:** El escritorio de un diseñador siempre está muy desordenado; puedes encontrar elementos LEGO de colores por todas partes, por no hablar de modelos parcialmente contruidos. Sabía que iba a necesitar espacio. Es muy importante despejar el escritorio en primer lugar, en especial cuando se trata de un set de este tamaño.

**P: ¿En qué se diferenció el diseño de la Batalla de Hoth de tu trabajo con otros modelos?**

**R:** En cuanto a número de elementos, el tamaño de la Batalla de Hoth se acerca al del set UCS *Slave I* que diseñé anteriormente. Sin embargo, mientras que la *Slave I* era un solo modelo de gran tamaño, la Batalla de Hoth se compone de muchos modelos más pequeños, algunos de ellos con funciones. Fue más como diseñar varios sets normales al mismo tiempo.



Hans Burkhard Schlömer



**P: La Batalla de Hoth es una de las más famosas del universo *Star Wars*™ y representó una importante victoria para el Imperio Galáctico en su momento. ¿En qué sentido afectó esto a los vehículos y minifiguras que incluyeron en el set?**

**R:** El equipo de LEGO® *Star Wars* diseñó primero un modelo preliminar del set. Nos concentramos en la base rebelde y construimos lo que teníamos en nuestras listas de deseos: modelos que no se habían hecho nunca hasta entonces, como el cañón de iones, el generador de energía o el pequeño vehículo rebelde. LEGO ha lanzado bastantes sets más pequeños basados en la Batalla de Hoth, pero hará mucho tiempo que fueron publicados cuando este salga a la venta. ¡Aquí tenemos la batalla entera en un solo set!

Uno de los personajes que no podía faltar en el set era Torgo, la oficial de operaciones de combate que ordena abrir fuego con el cañón de iones. ¡Acaba con todo un Destructor Estelar, así que tenía que estar ahí! También tenía en mi lista a K-3PO, el droide de protocolo blanco, que sólo había aparecido en otro set ocho años antes.

**P: Las características ambientales, como las formas angulosas de la nieve, dan vida al set con gran realismo. ¿Cómo suelen crear la atmósfera al diseñar un set LEGO® *Star Wars*?**

**R:** Para un diseñador es importante ser eficiente a la hora de crear los detalles ambientales, sin dejar de concentrarse en lo básico, como las funciones y las posibilidades de juego. Tener enormes dunas de nieve sería impresionante, pero no aportaría demasiado al set en cuanto a valor recreativo. Aunque existen muchas técnicas de construcción que permiten crear paisajes con bricks LEGO (como la construcción lateral o el uso de elementos transparentes), preferí quedarme con lo fundamental para acelerar la experiencia, de modo que el constructor pueda concentrarse en las cosas divertidas, como el armamento rebelde. Por suerte, ¡simular la nieve con bricks LEGO es coser y cantar!

**P: Hoth es un planeta helado en el que nieva constantemente, y la Batalla de Hoth es un set que se construye principalmente empleando bricks blancos. Al trabajar con tantos bricks LEGO del mismo color, ¿cómo logran que destaquen secciones específicas del set?**

**R:** Quizá debiera mencionar que nuestros escritorios también son blancos... ¡¡imaginen! Siempre incluimos elementos pálidos en los sets LEGO para diferenciarlos entre sí y facilitar el proceso de construcción. A veces, los bricks son de colores MUY parecidos. ¡Acuérdense de mí cuando encuentren los bricks azul oscuro ocultos dentro del generador de energía!

Dicho eso, la nieve tiene que ser blanca y Hoth es una gran bola de nieve. Experimenté mezclando elementos en azul marino claro, como si fuese hielo de otro color, pero no se veían bien en la trinchera ni en la puerta. Funcionó mejor dentro de la cueva del Wampa, donde hay más hielo que nieve.



**P: ¿Qué técnicas usaron al diseñar y construir el set para asegurarse de que fuese sólido?**

**R:** La estabilidad del modelo es muy importante y, a menudo, el poder de conexión de los bricks no es suficiente para garantizar la firmeza. Una de las técnicas más importantes es la de bloqueo vertical: las vigas LEGO® Technic de color blanco situadas detrás de la entrada de la base impiden que las capas de bricks se descompongan fácilmente y proporcionan puntos de fijación a los módulos de la base.

**P: La Batalla de Hoth fue una gran batalla. Con tanto material disponible, ¿cómo decidieron qué elementos debían formar parte del set?**

**R:** Había cosas que tenían que estar ahí, como la entrada de la base. O el aerodeslizador de las nieves, principal caza de la Alianza Rebelde en Hoth. Como el aerodeslizador de las nieves de Luke (con marcas gris oscuro) fue reeditado el año pasado, incluimos la versión normal del Escuadrón Pícaro, que tiene marcas de color naranja.

También queríamos recuperar al Wampa con su guarida y agregar detalles al interior de la base. Todo gira en torno a la base rebelde, así que la presencia imperial en este set es poco notoria. El nuevo AT-AT está disponible desde el año pasado, así que es posible recrear toda la batalla. ¡Además, los soldados de las nieves tienen un nuevo bláster E-web que dispara realmente!

**P: ¿Hay alguna característica concreta de la Batalla de Hoth que te guste especialmente?**

**R:** Nos tomamos cierta libertad al crear la atalaya extensible. Es un detalle que tomamos de la base rebelde de Yavin 4, que aparece en la película anterior; asumimos que todas las bases rebeldes tenían que tener atalayas, sólo que no se ven en *El Imperio Contraataca*. De todos modos, los rebeldes tenían que vigilar siempre a los soldados imperiales, ¿no? ¡Incluso en un planeta helado como este!



© & ™ Lucasfilm Ltd.

**P: El set tiene muchos detalles, especialmente por detrás. Hablamos de las puertas deslizantes acorazadas, las torretas lanzamisiles o el generador de energía que explota. ¿Cómo trabajan en las funciones durante el diseño de un set? ¿Es difícil diseñar un set con partes móviles?**

**R:** Sin duda, las partes móviles hacen mis días más... ¡interesantes! Construir un par de puertas deslizantes suele ser muy fácil, pero las cosas cambian con un set LEGO. Tenemos que dejar espacio para los errores de construcción y la manipulación del modelo. Prever todo lo que puede ir mal y evitar que suceda no es tarea fácil. Después de todo, no se vale que las puertas acorazadas se queden a medio cerrar sólo porque no presionaste un par de placas con la fuerza suficiente al construir el modelo. Eso haría reír al mismo Darth Vader... ¡pondría las cosas MUY fáciles al Imperio!



# Conoce al diseñador gráfico

Paul Constantin Turcanu

**P: Como diseñador gráfico de The LEGO Group, ¿en qué consiste principalmente tu trabajo?**

**R:** Mi labor consiste en diseñar los gráficos de las minifiguras y los adhesivos.

**P: ¿Cuánto tiempo llevas trabajando en LEGO® Star Wars™?**

**R:** Comencé a trabajar para The LEGO Group hace dos años y me incorporé al proyecto *Star Wars* inmediatamente.

**P: ¿Qué usas para diseñar los adornos de las minifiguras LEGO Star Wars?**

**R:** Normalmente, lo primero que hago es volver a ver las escenas en las que aparecen las minifiguras o estudiar las referencias oficiales. Me gusta empezar dibujando en papel y, cuando estoy satisfecho con el resultado, trazar el diseño digitalmente.

**P: Las minifiguras son muy pequeñas. ¿A qué desafíos te enfrentas al crear diseños que sean detallados y, al mismo tiempo, fáciles de comprender?**

**R:** La clave es hacerlo sencillo. Por supuesto, cuando tenemos una referencia muy detallada, intentamos traducirla al lenguaje de LEGO® llamando la atención sobre las partes más emblemáticas para que sea fácilmente reconocible.



Paul Constantin Turcanu

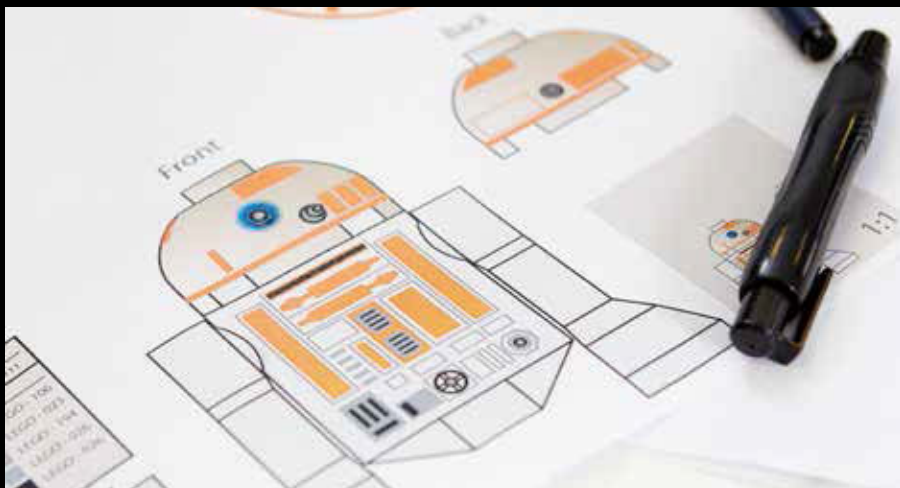

© & ™ Lucasfilm Ltd.

**P: ¿Qué materiales de referencia usas para diseñar los adornos de las minifiguras? ¿Fotogramas de la película? ¿Material artístico oficial?**

**R:** En el caso de las películas más recientes de la saga *Star Wars*, las referencias oficiales son muy buenas. Cuando se trata de las tres primeras, puede ser complicado incluso con las ilustraciones oficiales. Volver a ver las escenas o jugar videojuegos relacionados suele ser de gran ayuda.

**P: Muchos de los personajes que aparecen en este set no interpretan grandes papeles en las películas de *Star Wars*™. ¿Cómo conseguiste darles vida en el set sin tener buenas referencias?**

**R:** Personalmente, soy un gran fan de esos personajes secundarios y me divierte crear minifiguras geniales a partir de cosas que no son tan emblemáticas. Lo bueno es que, cuando empiezo a investigar, me doy cuenta de que todos tienen su propia historia; es fantástico profundizar en el vasto universo que es *Star Wars*. Ayuda mucho asignar una personalidad al personaje: valiente, cobarde, decidido o aventurero.

**P: ¿Hay alguna minifigura con la que hayas disfrutado especialmente al diseñarla?**

**R:** Me gustó mucho trabajar en el R3-A2, quizá porque es la primera vez que aparece en un producto LEGO®. Apenas puedes verlo en la película, pero estoy seguro de que los fans lo apreciarán. Además, los detalles impresos en el elemento transparente aportan mucho a su aspecto en general.

**P: Además de las minifiguras normales con forma de seres humanos, hay un buen número de extraterrestres, droides y extrañas criaturas en la Batalla de Hoth. ¿Qué cosas cambian al diseñar los adornos de criaturas tan diferentes?**

**R:** Intentamos que la decoración sea lo más emblemática y eficiente posible. Incluso aunque se trate de animales o extraterrestres, tratamos de ser tan fieles como podemos a nuestra guía de estilo y mantener las características gráficas comunes de las minifiguras normales.



© & ™ Lucasfilm Ltd.









75095 TIE Fighter™





75060 Slave I™



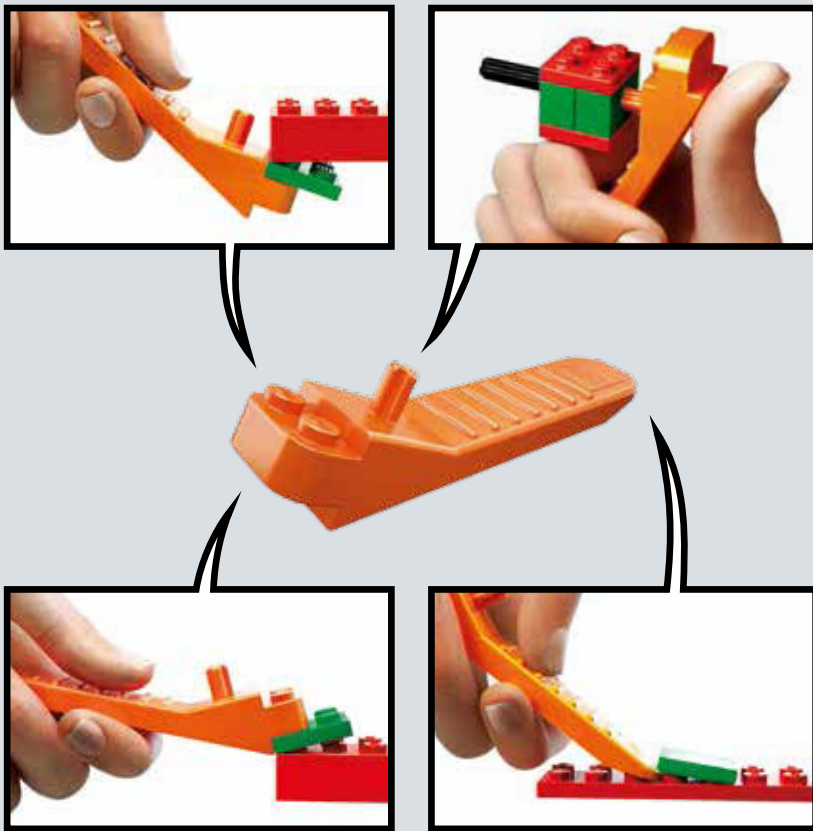

[LEGO.com/brickseparator](https://LEGO.com/brickseparator)

IMPORTANT: Never modify the elements or use other projectiles than provided with this toy.  
 IMPORTANT : Ne jamais modifier les éléments ni utiliser d'autres projectiles que ceux fournis avec ce jouet.  
 IMPORTANTE: No modifique los elementos ni utilice otros proyectiles diferentes a los suministrados junto con este juguete.



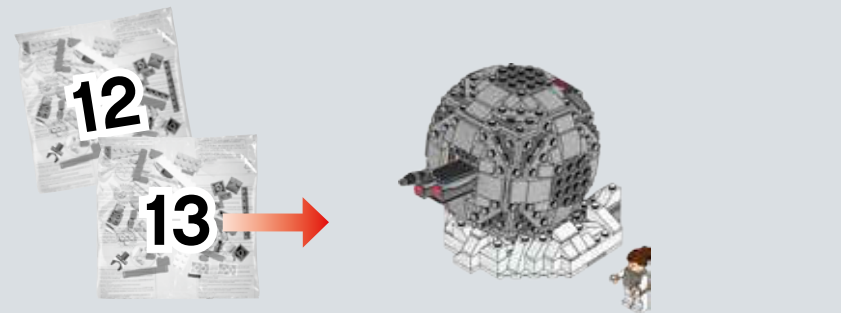
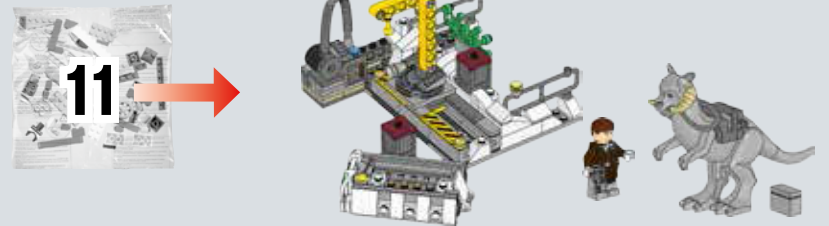
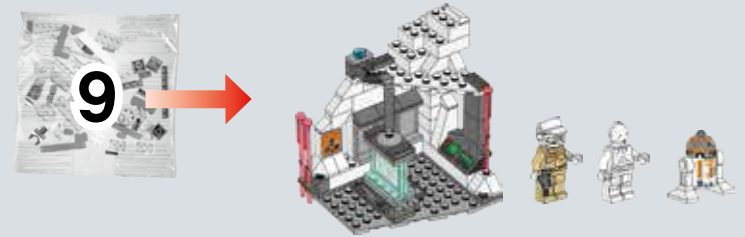
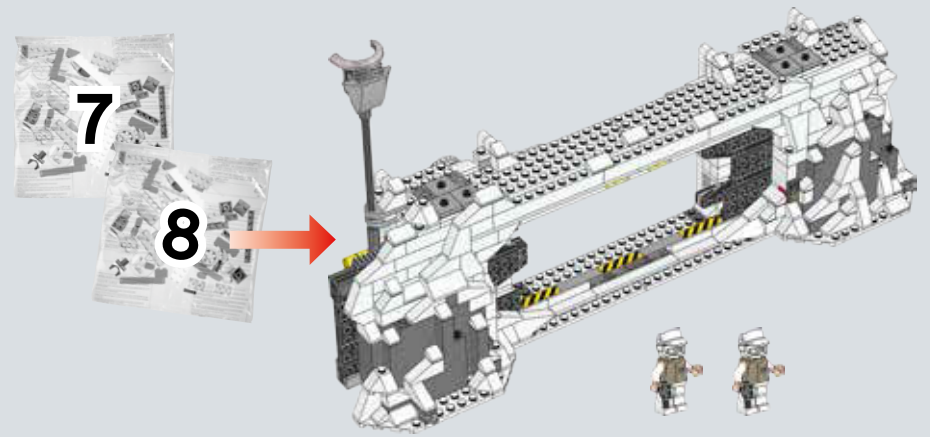
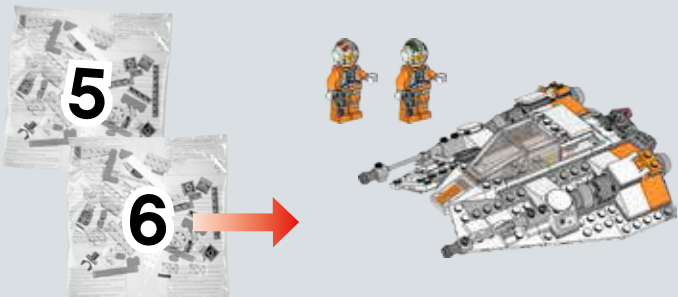
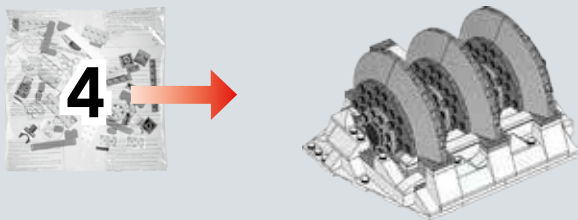
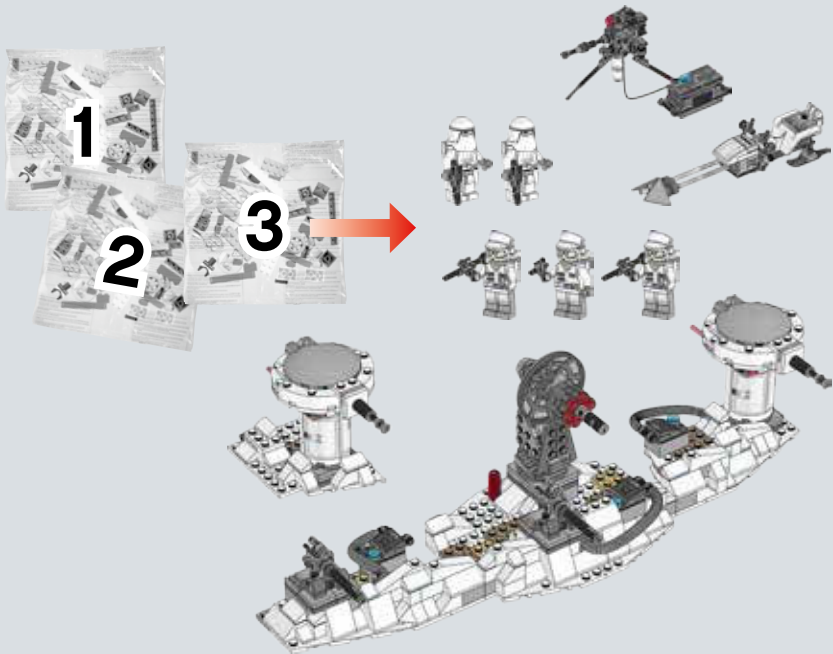

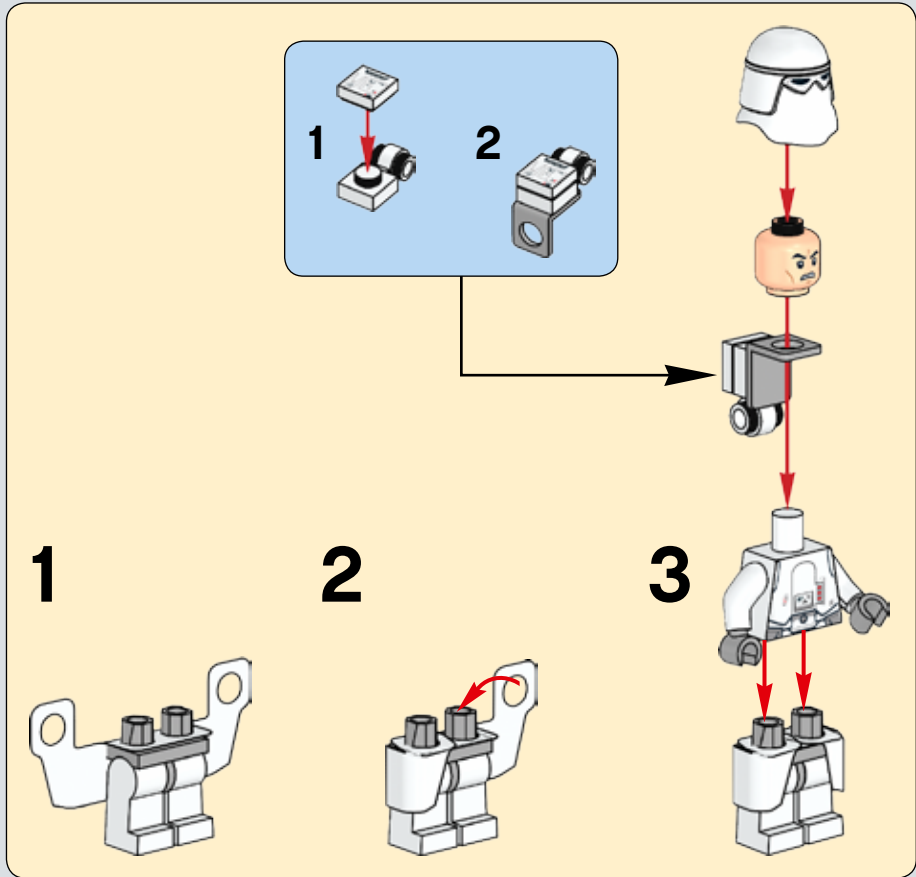
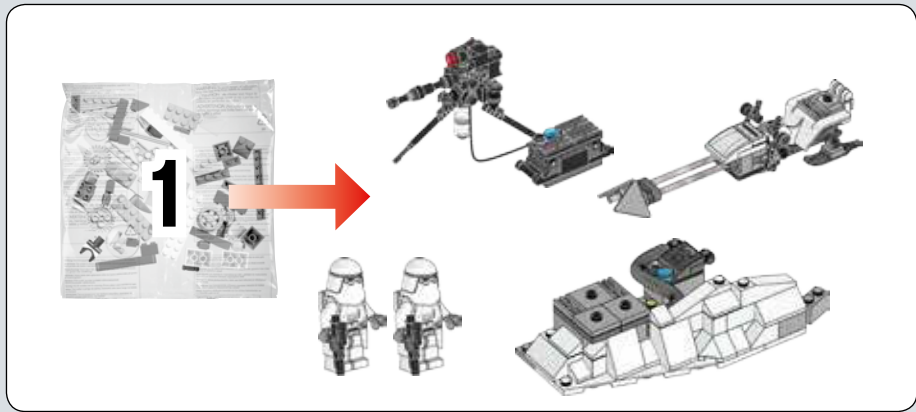



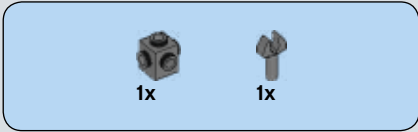

**1**

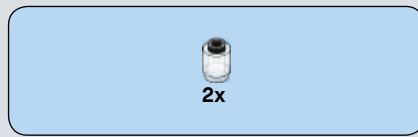
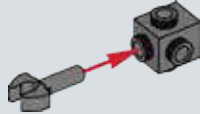

**2**

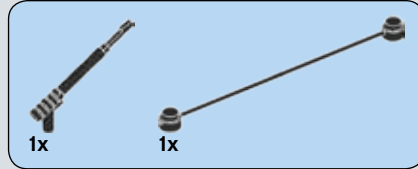
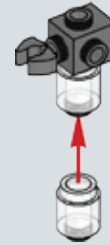

**3**



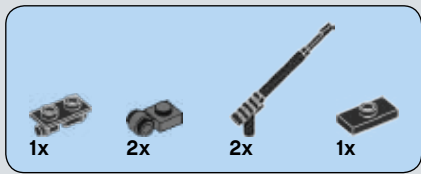

4

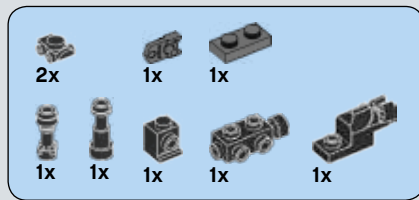
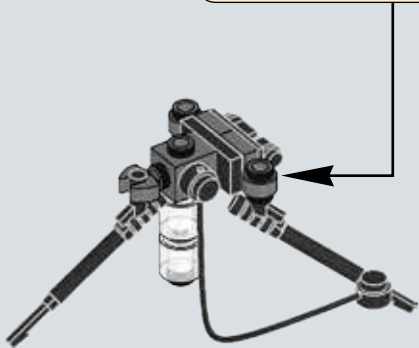
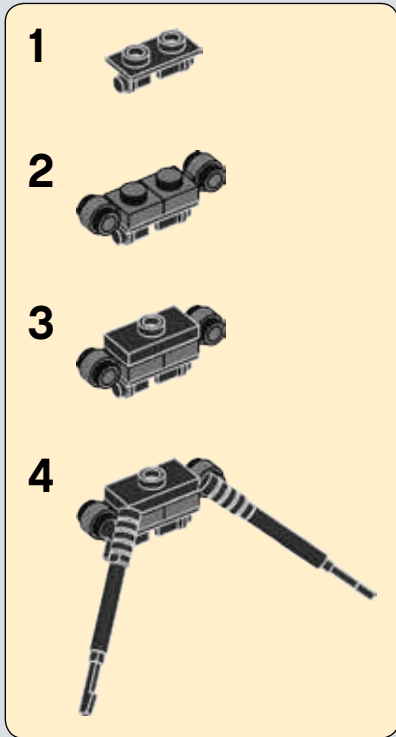

5

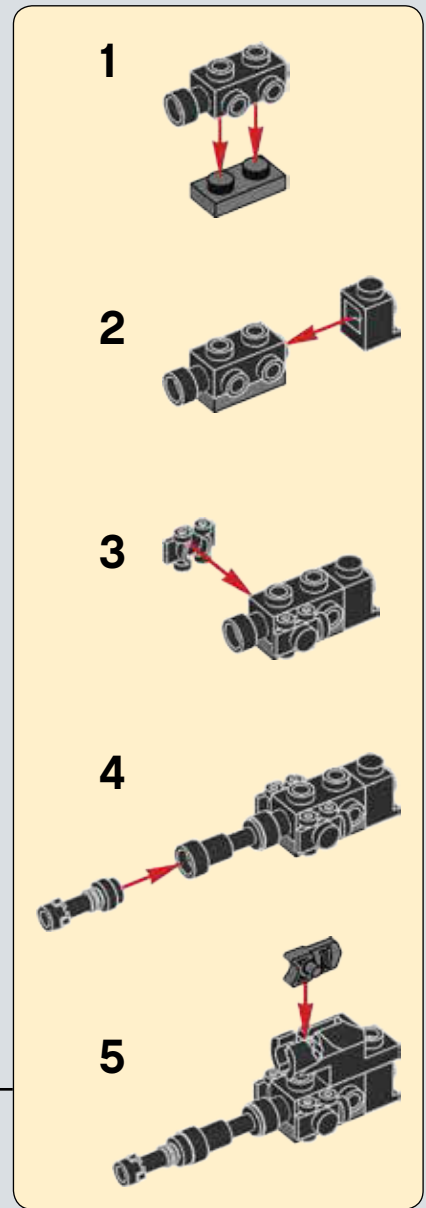
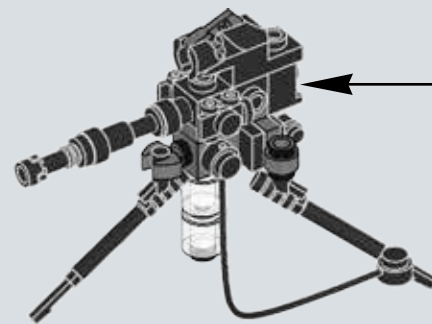



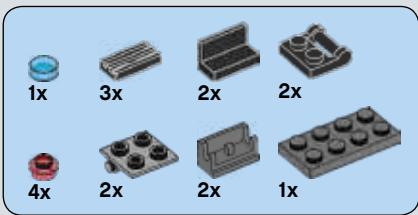

# 6

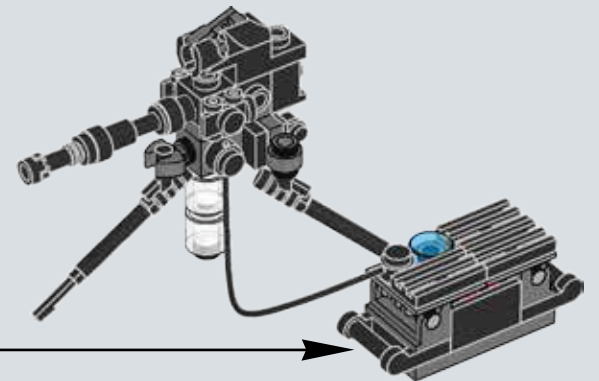
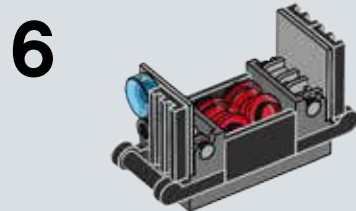
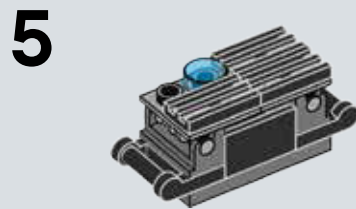
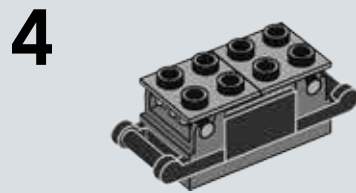
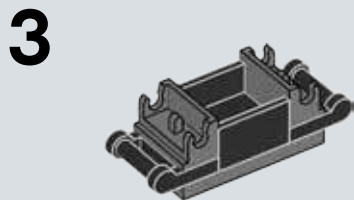
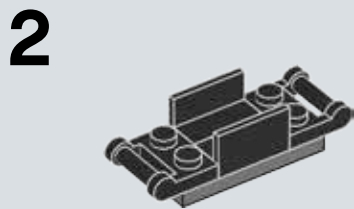
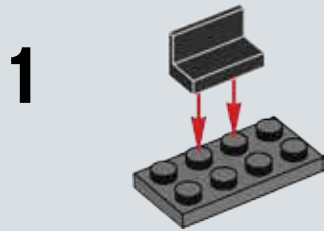

1x

7

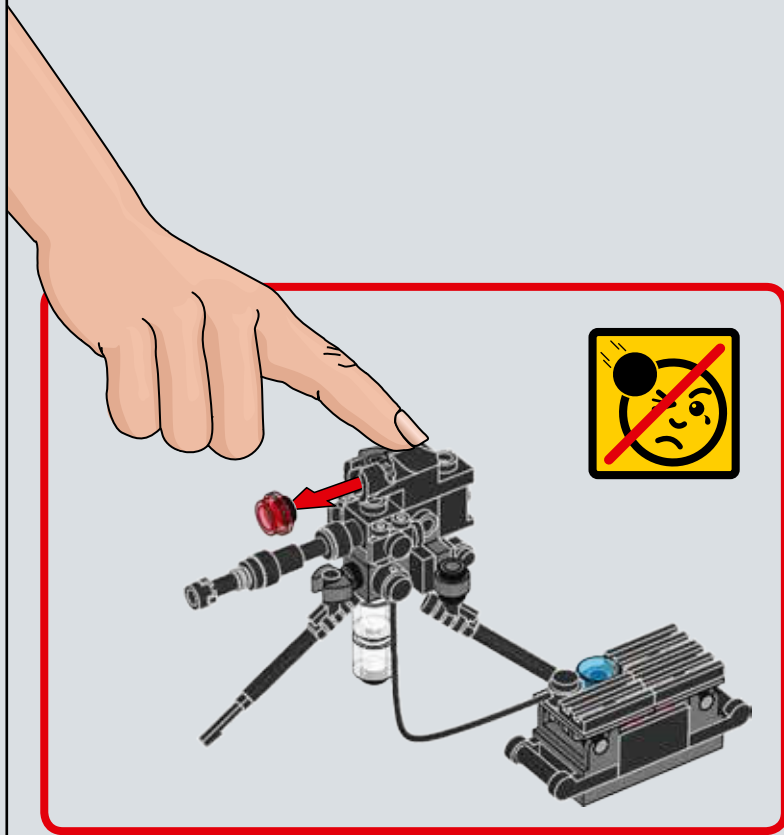
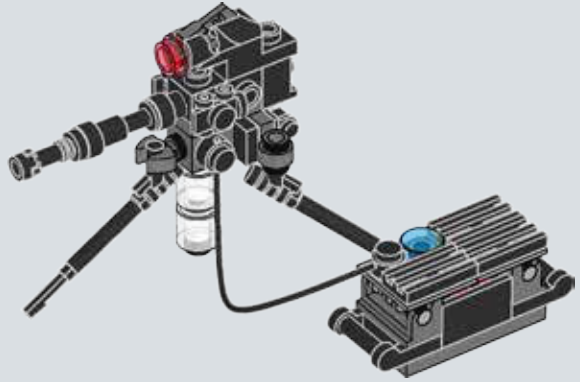



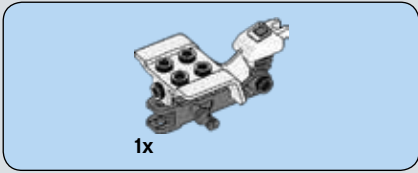
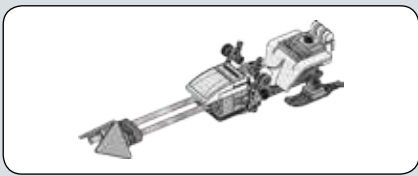

1

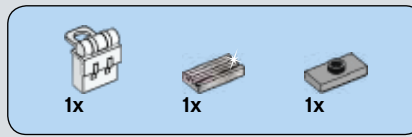
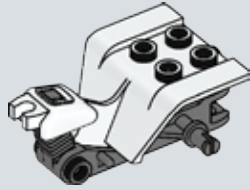

2

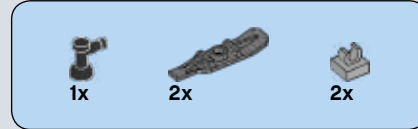
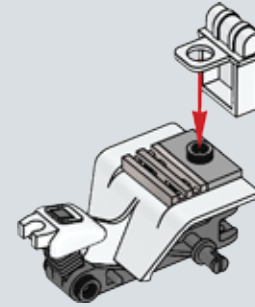

3

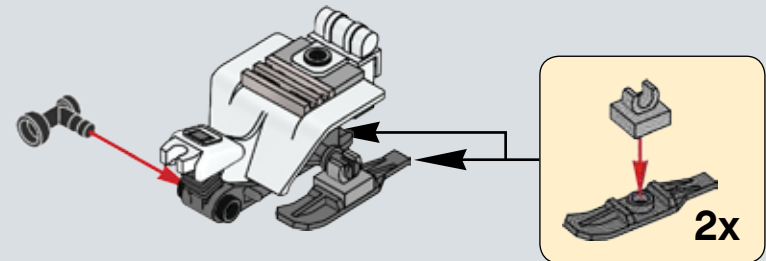

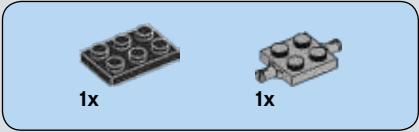

4

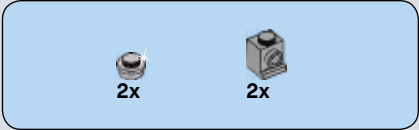
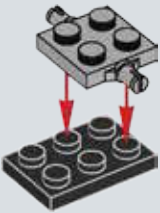

5

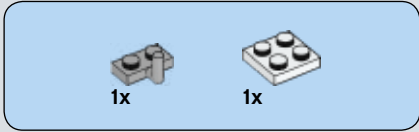
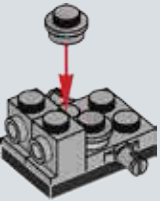

6

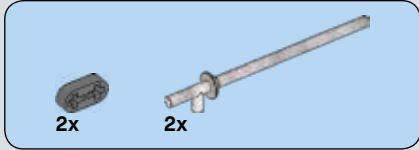
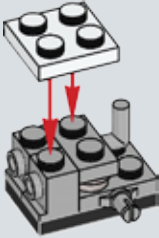

7

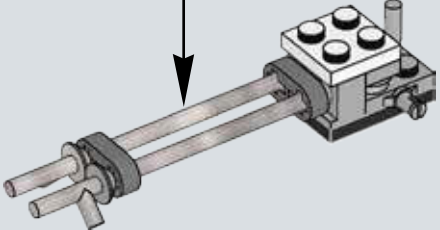
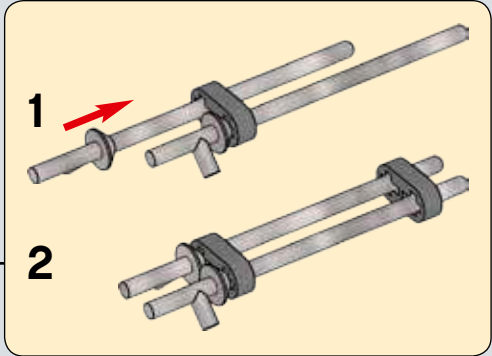



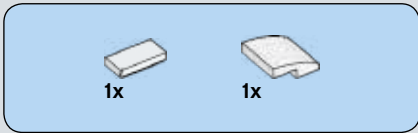

8

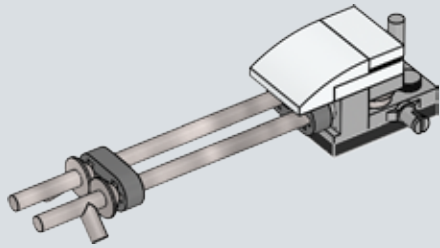

9

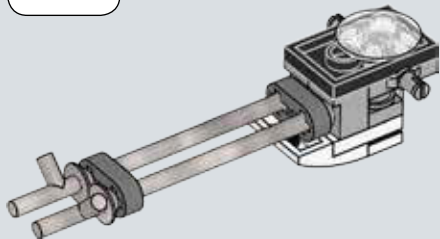
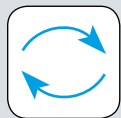

10

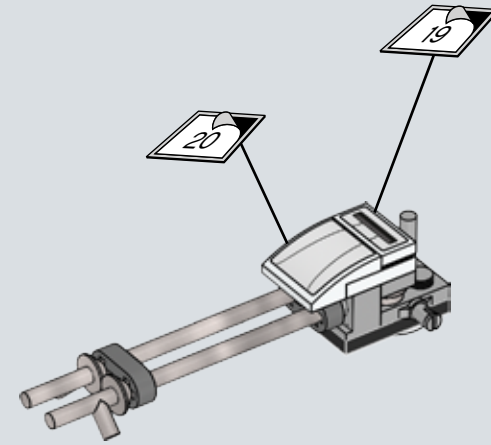
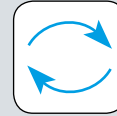

11

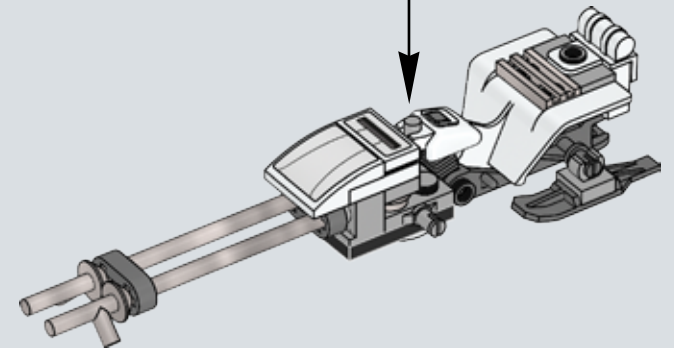



2x



2x

# 12

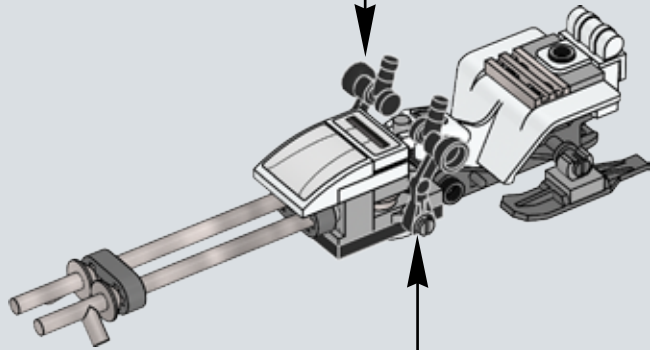
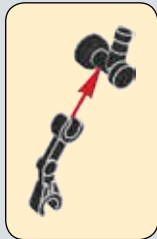

2x

# 13

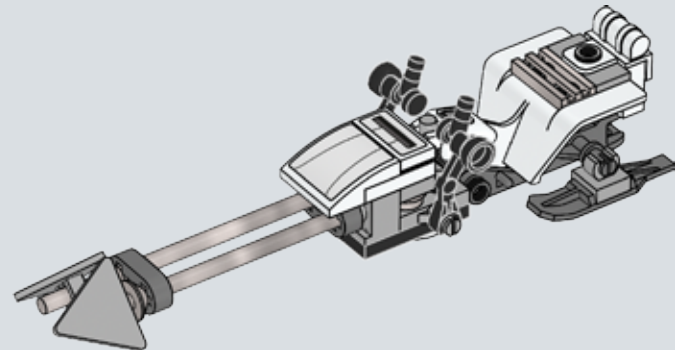



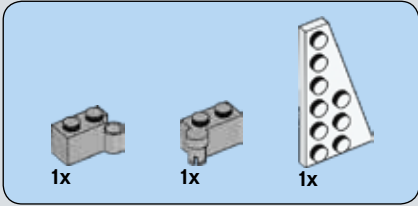
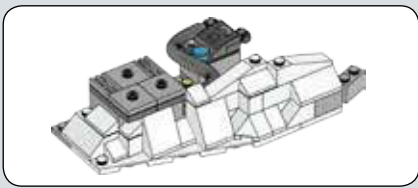

1

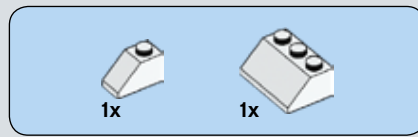
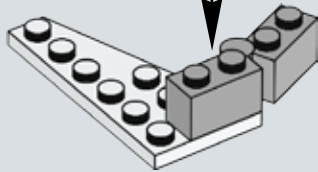
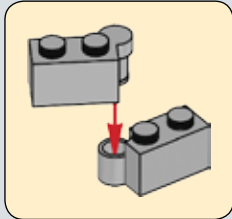

2

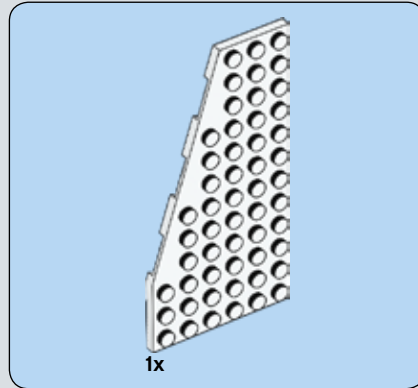
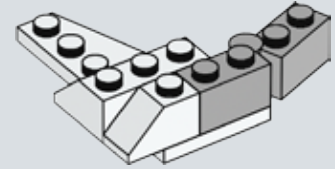

3

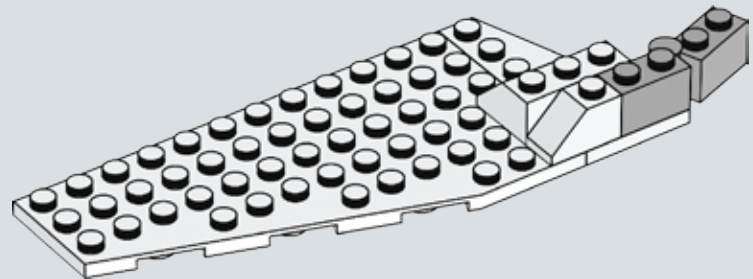

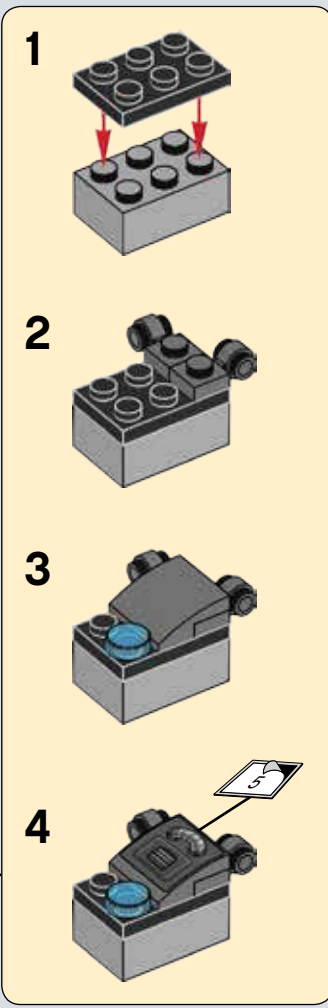
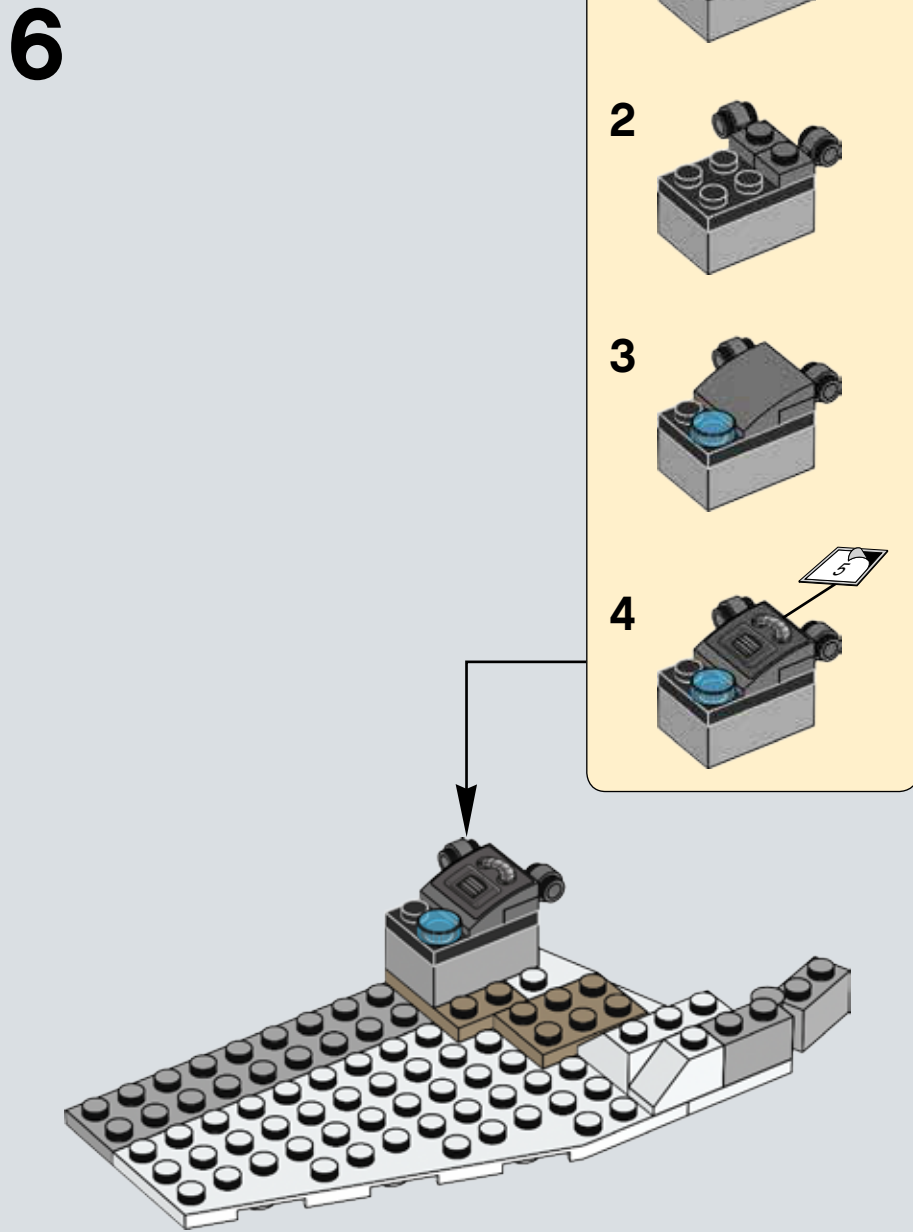
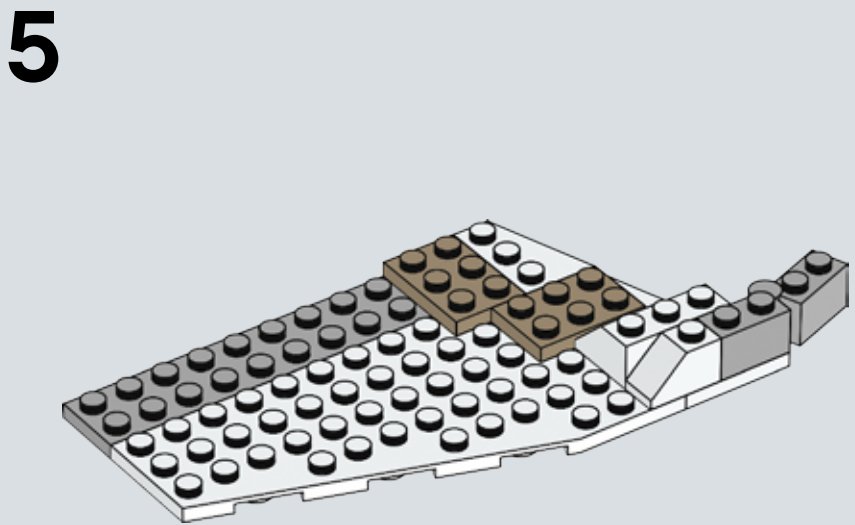
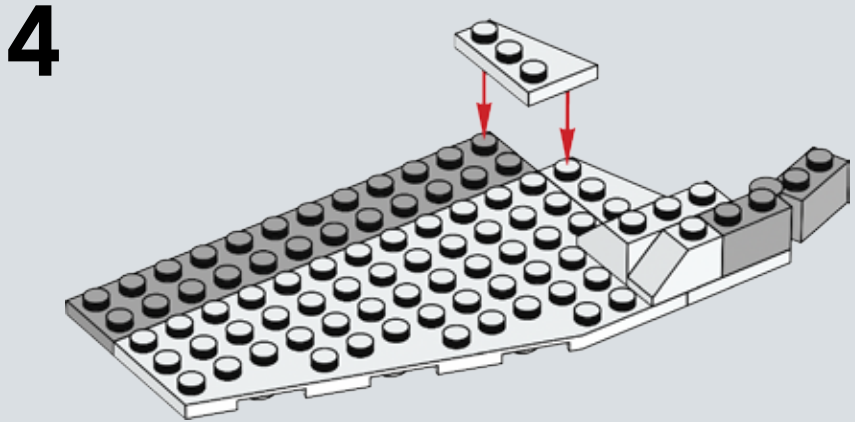
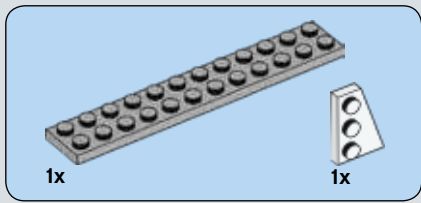





7

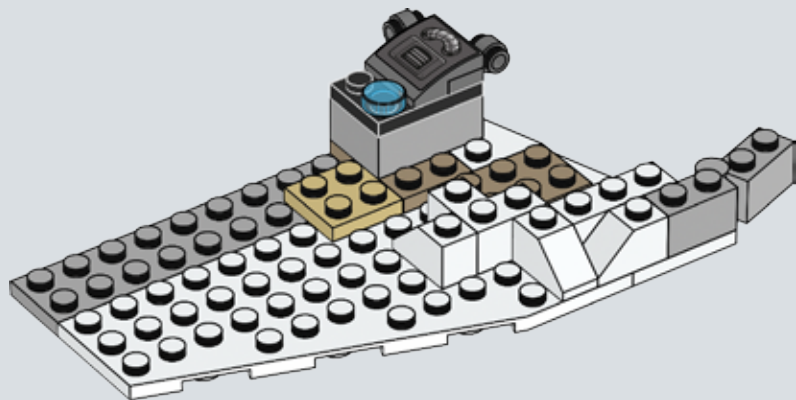

8

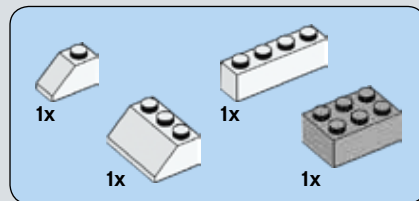
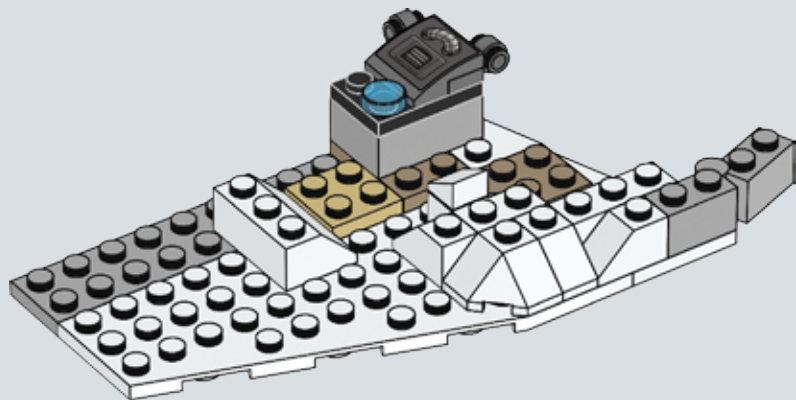

9

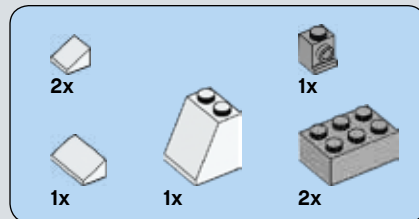
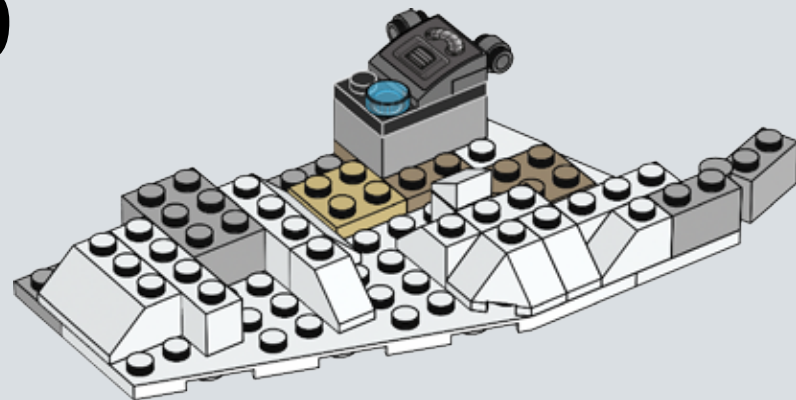

10

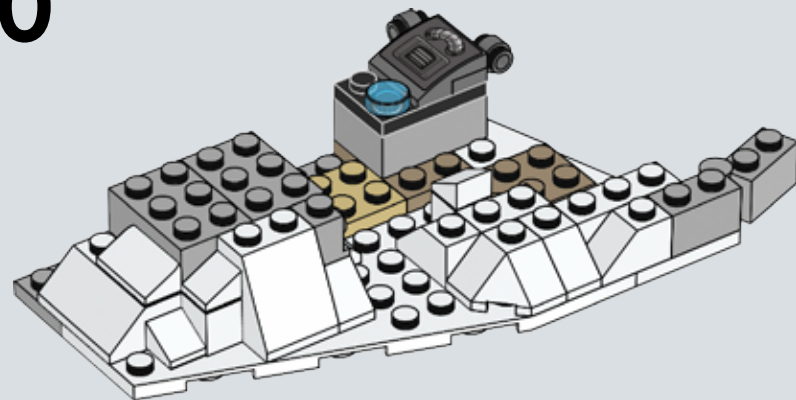

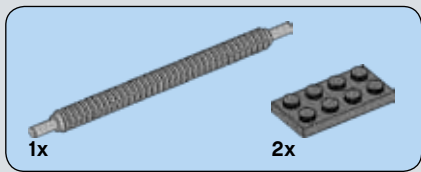

11

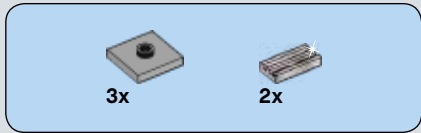
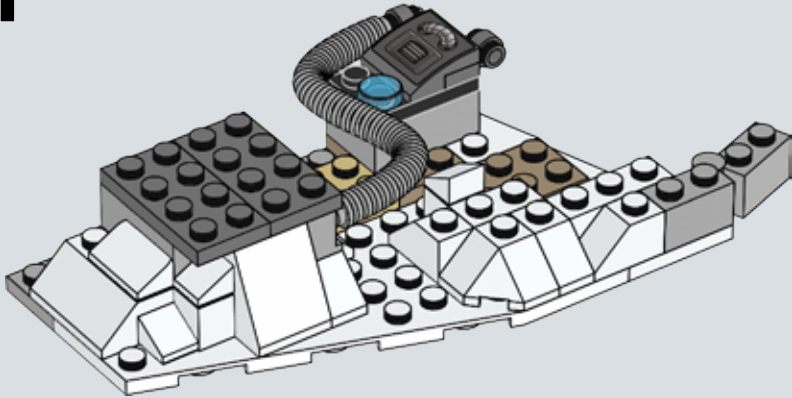

12

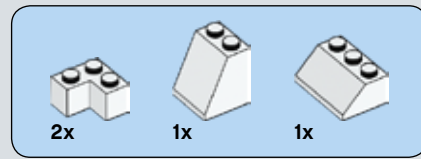
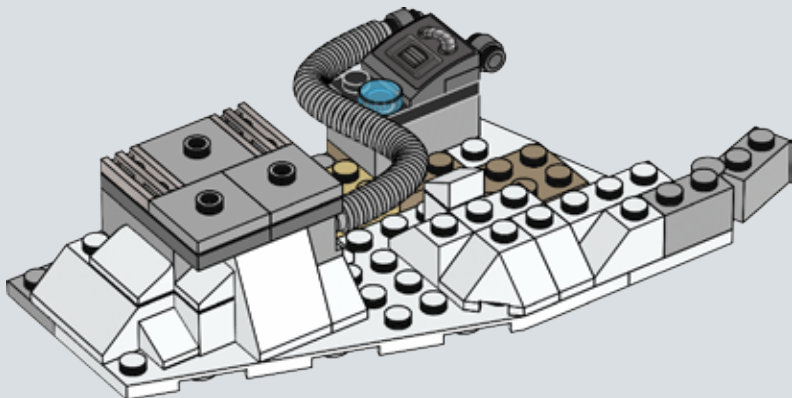

13

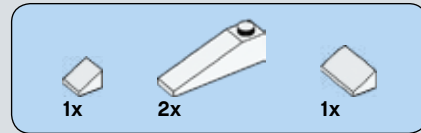
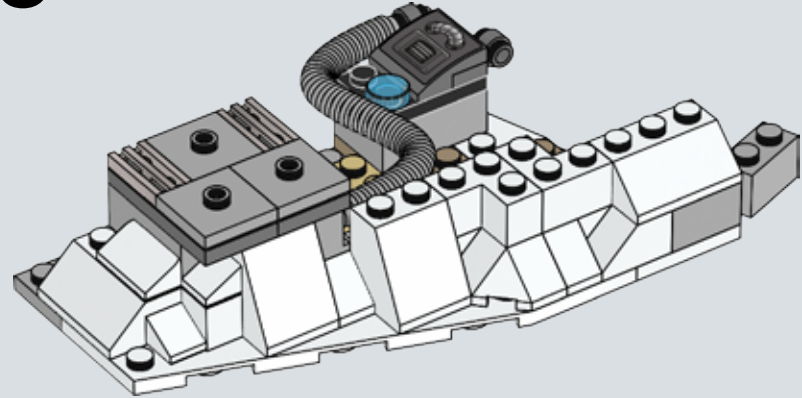

14

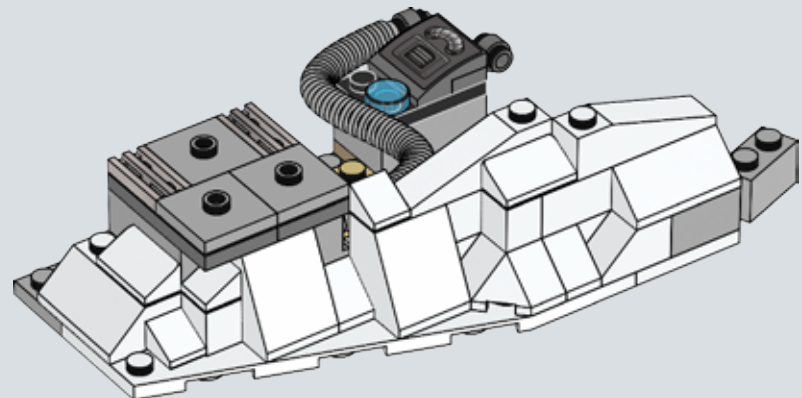

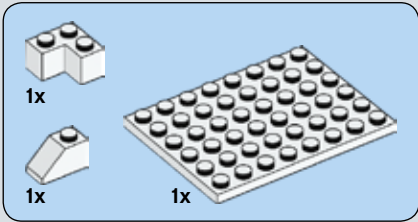
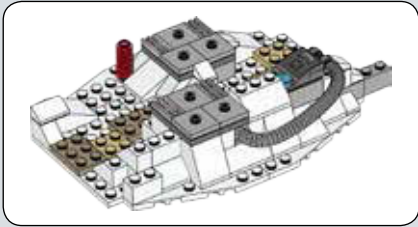
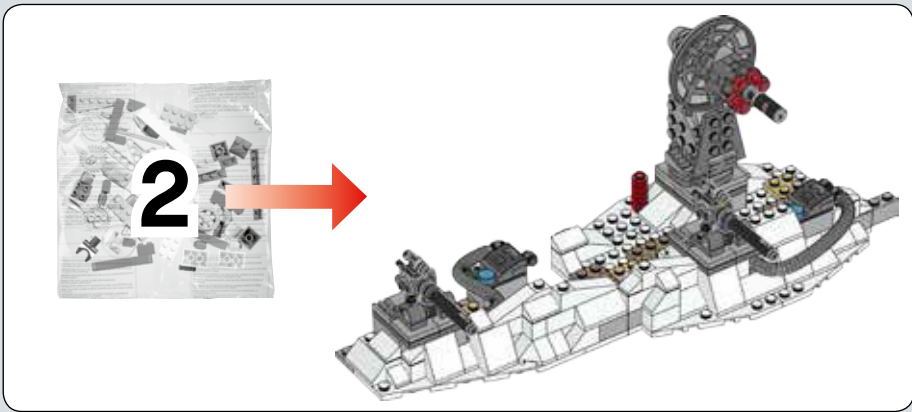

15

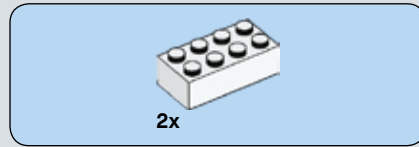
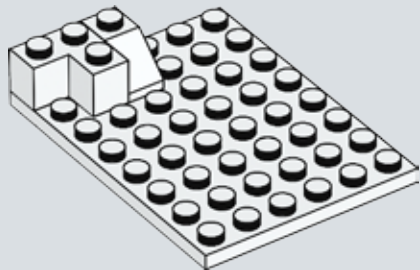

16

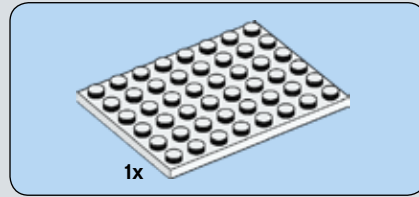
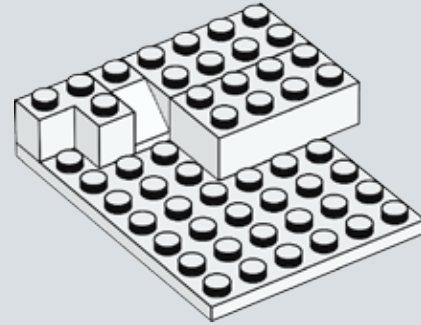

17

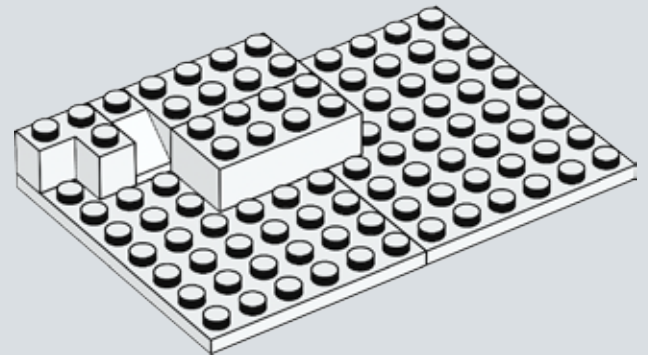



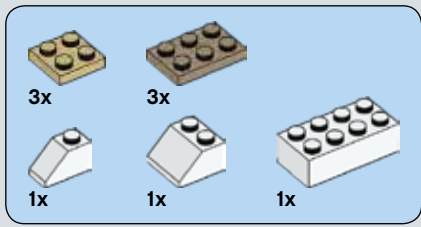

18

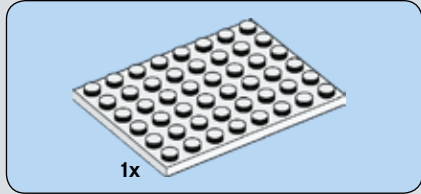
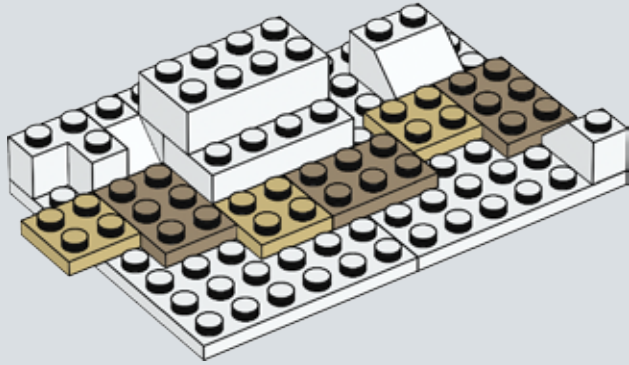

19

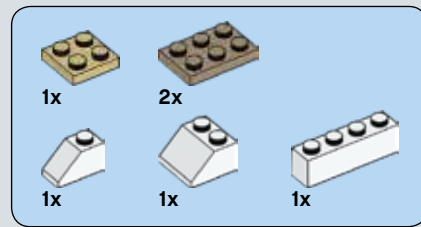
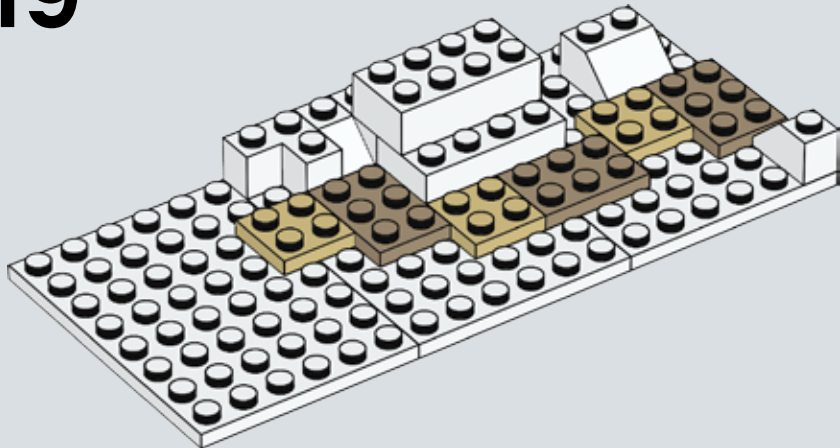

20

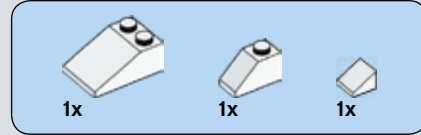
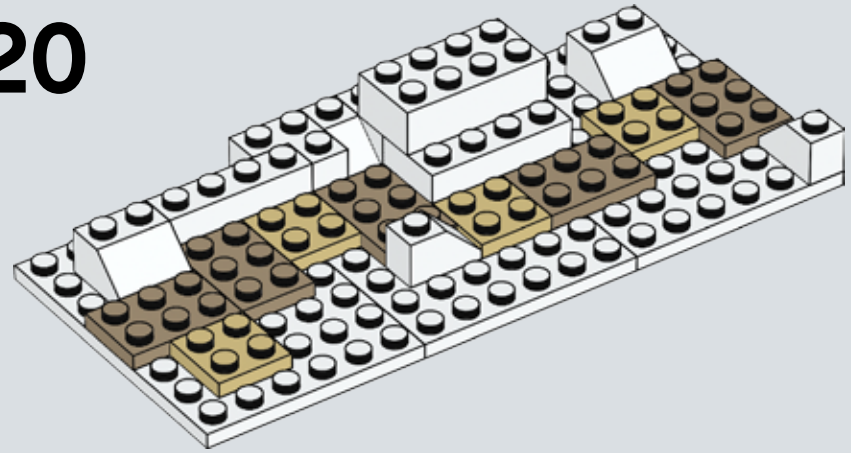

21

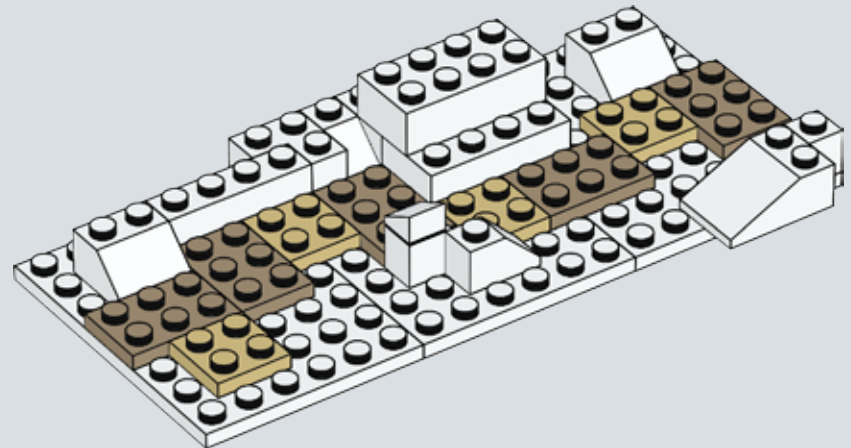

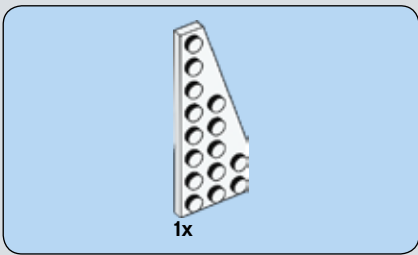

22

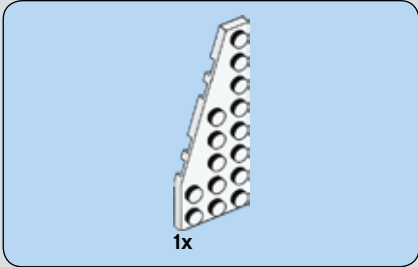
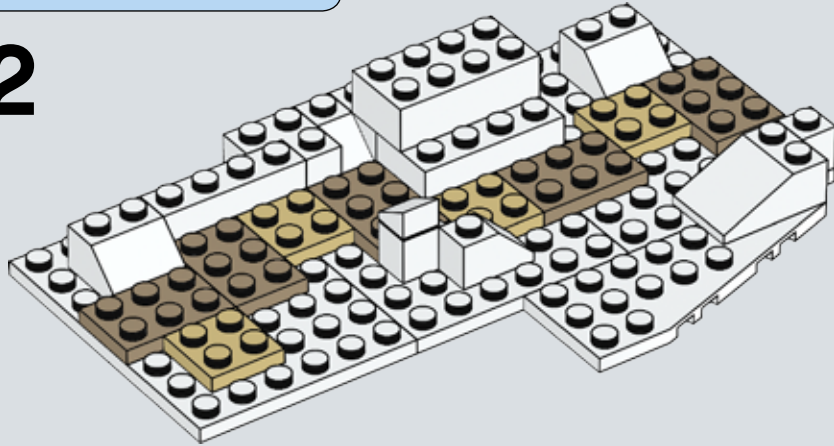

23

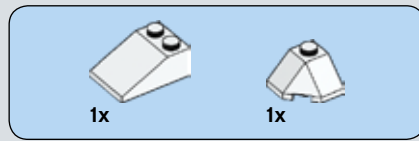
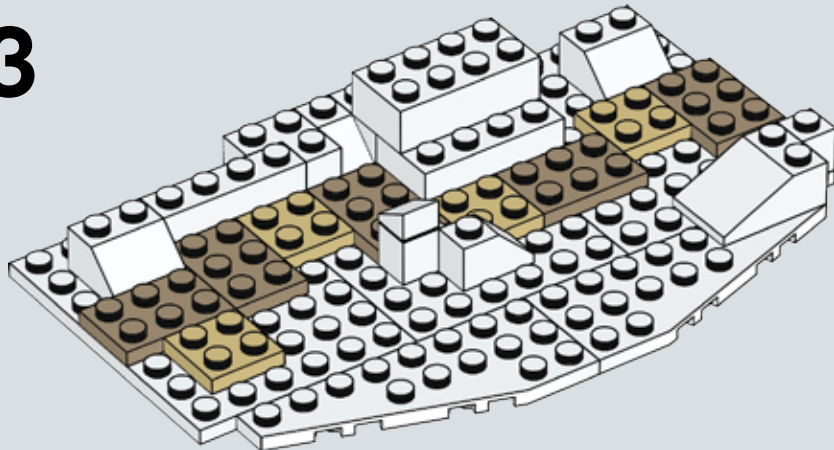

24

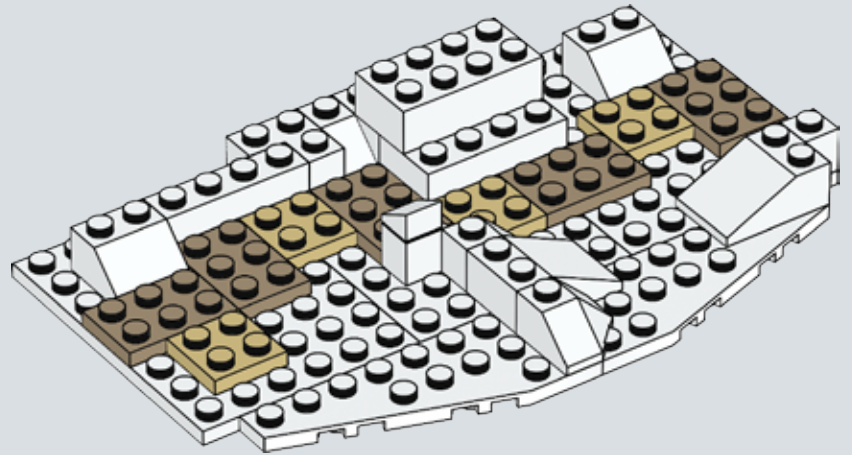

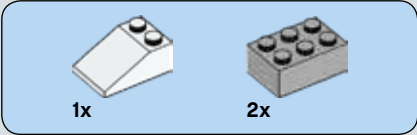

25

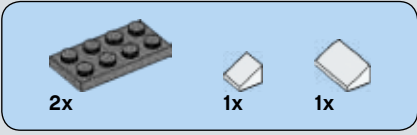
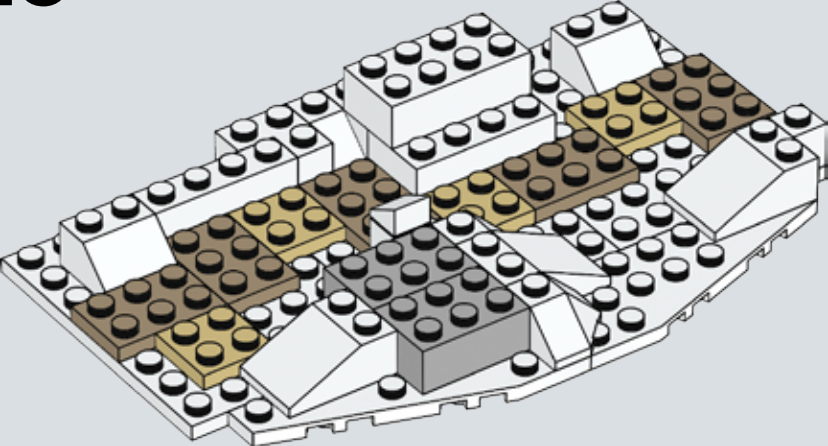

26

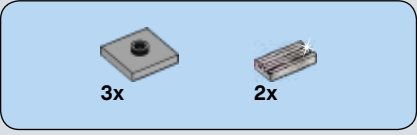
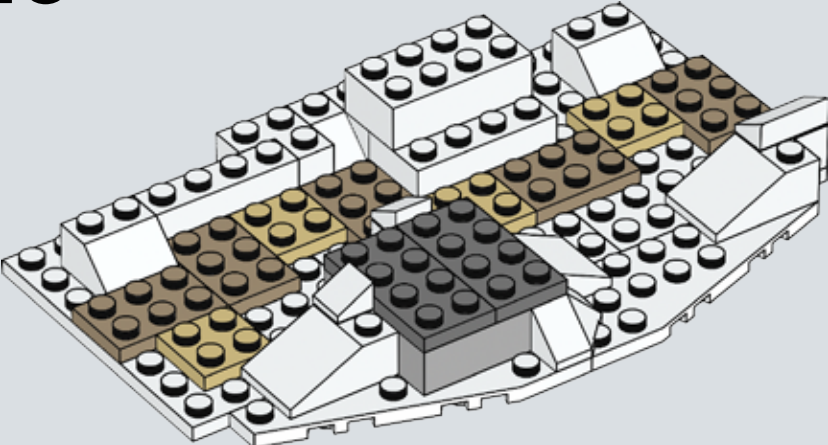

27

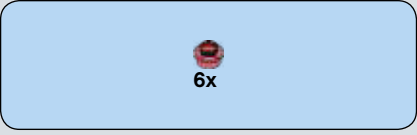
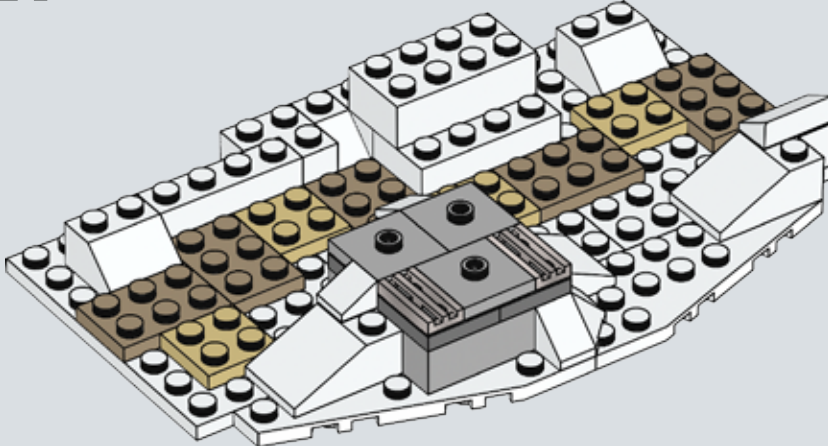

28

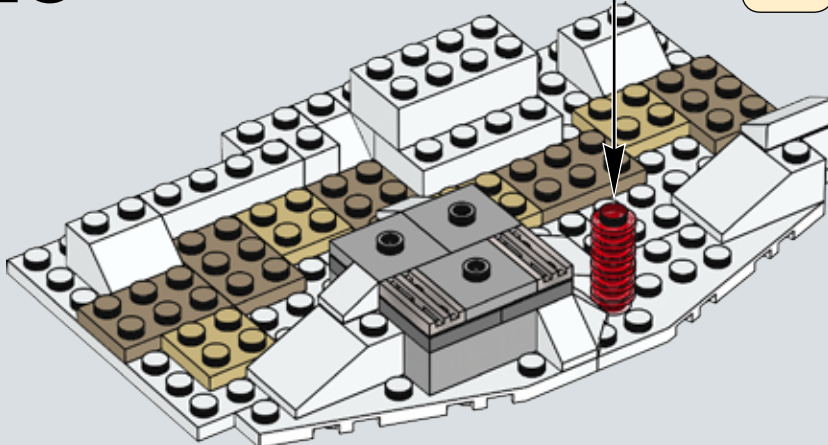



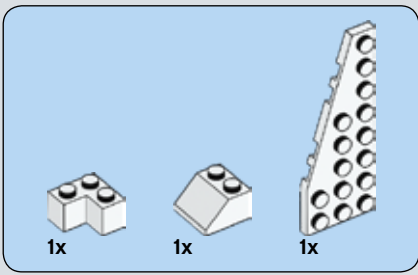

# 29

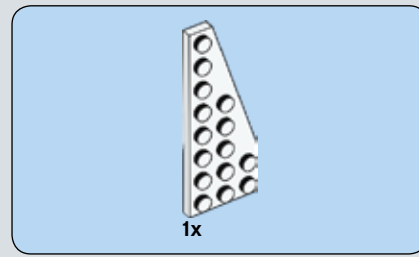
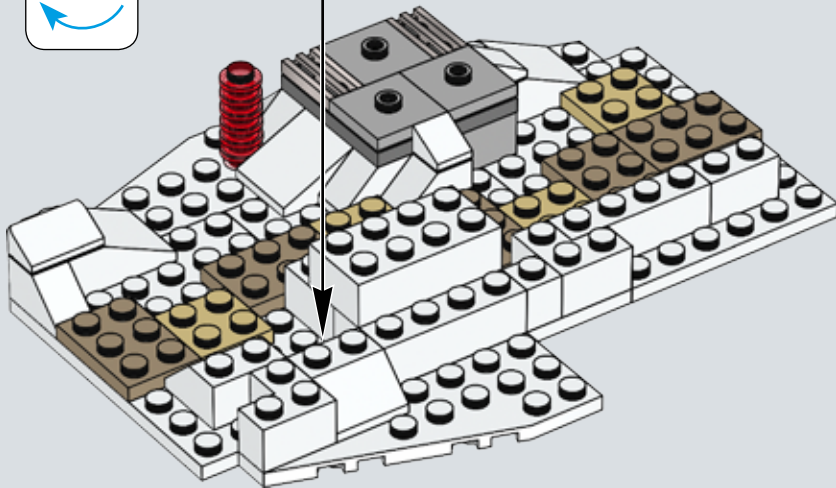
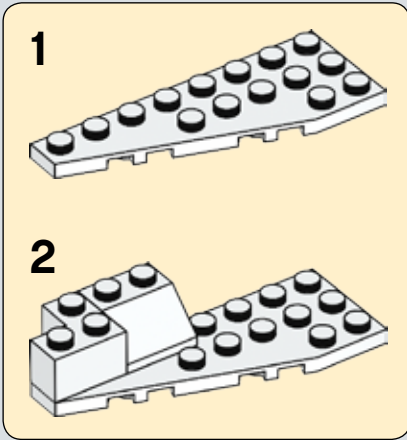

# 30

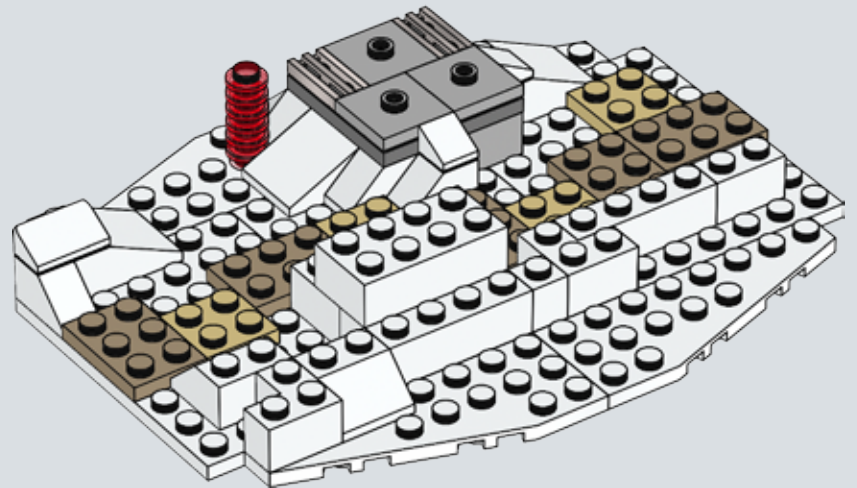

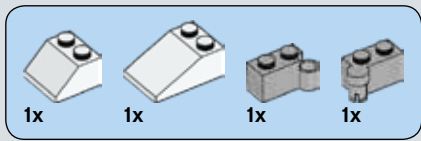

# 31

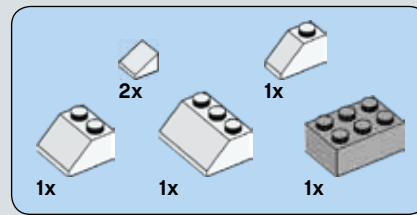
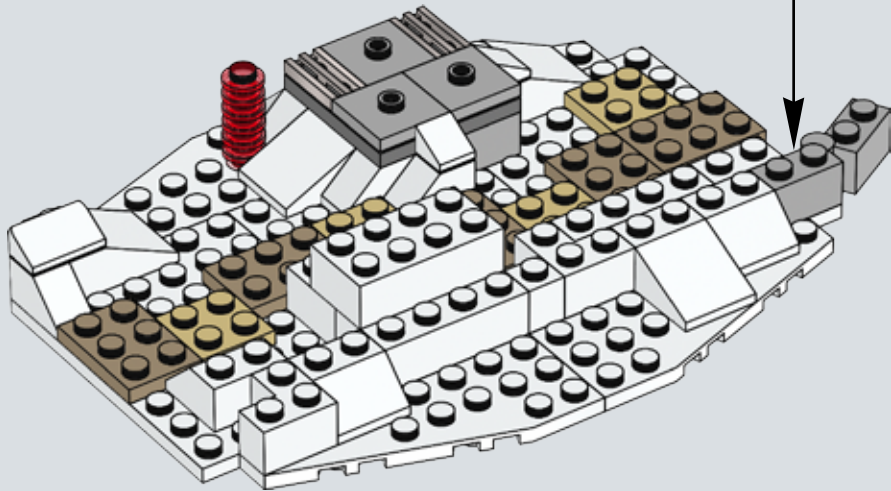
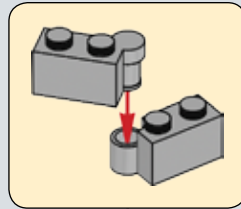

# 32

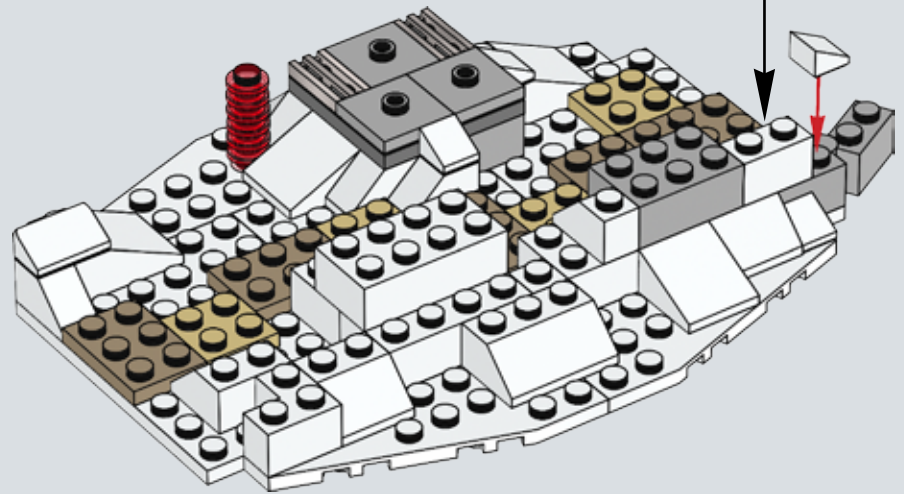
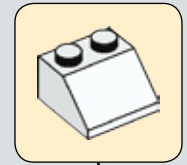

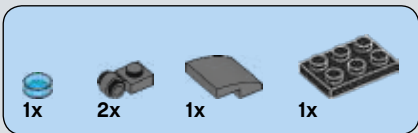

# 33

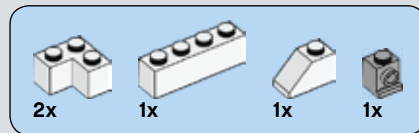
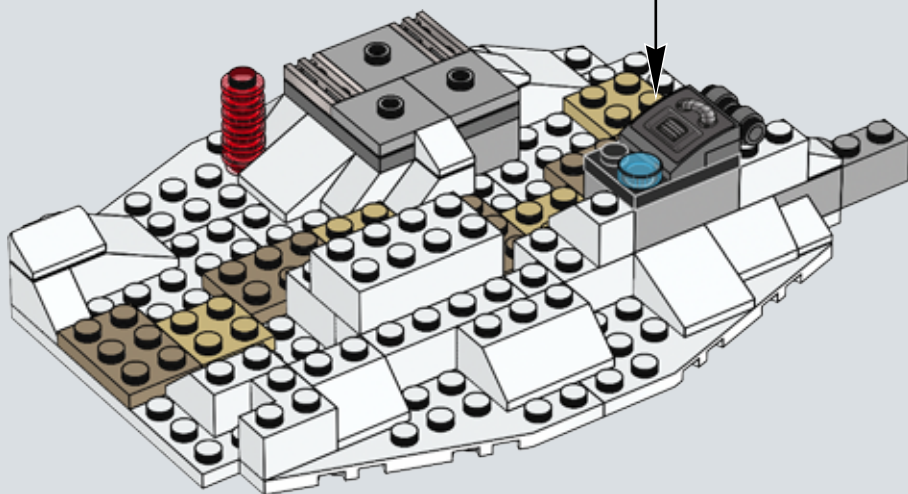

# 34

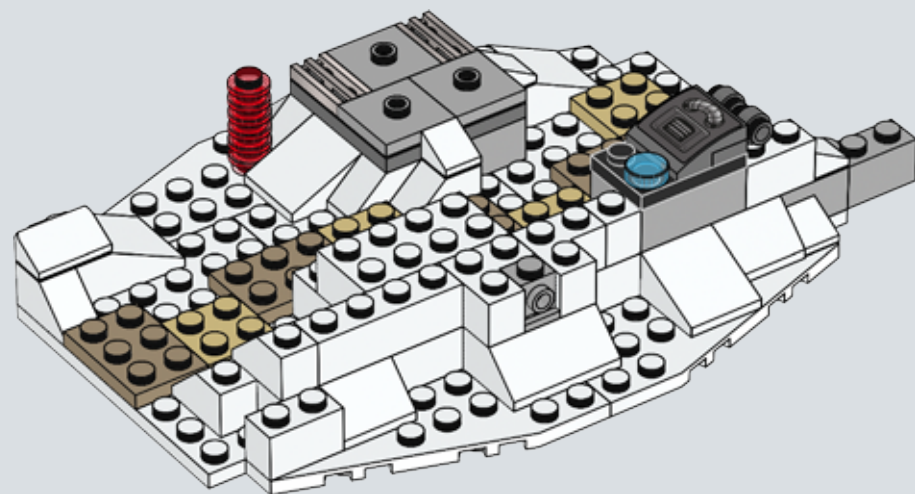





# 35

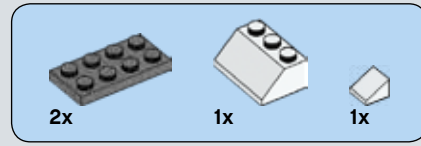
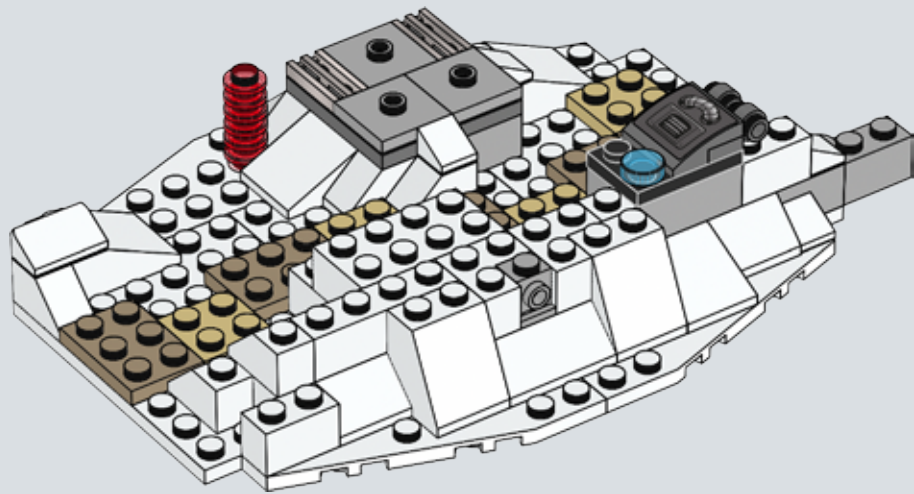

# 36

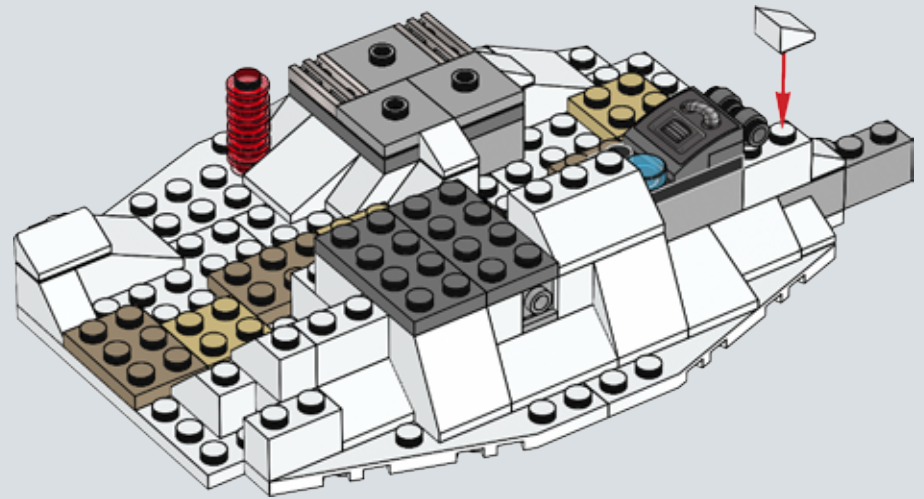

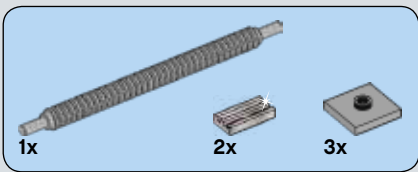

37

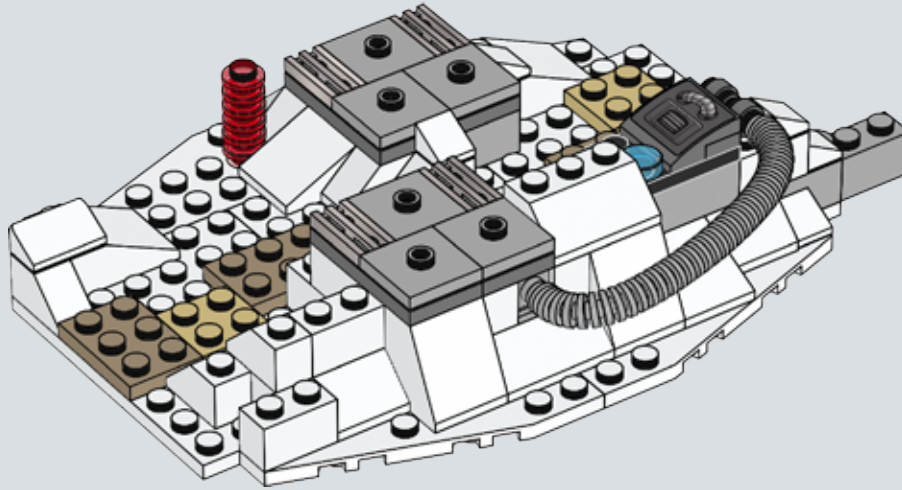

38

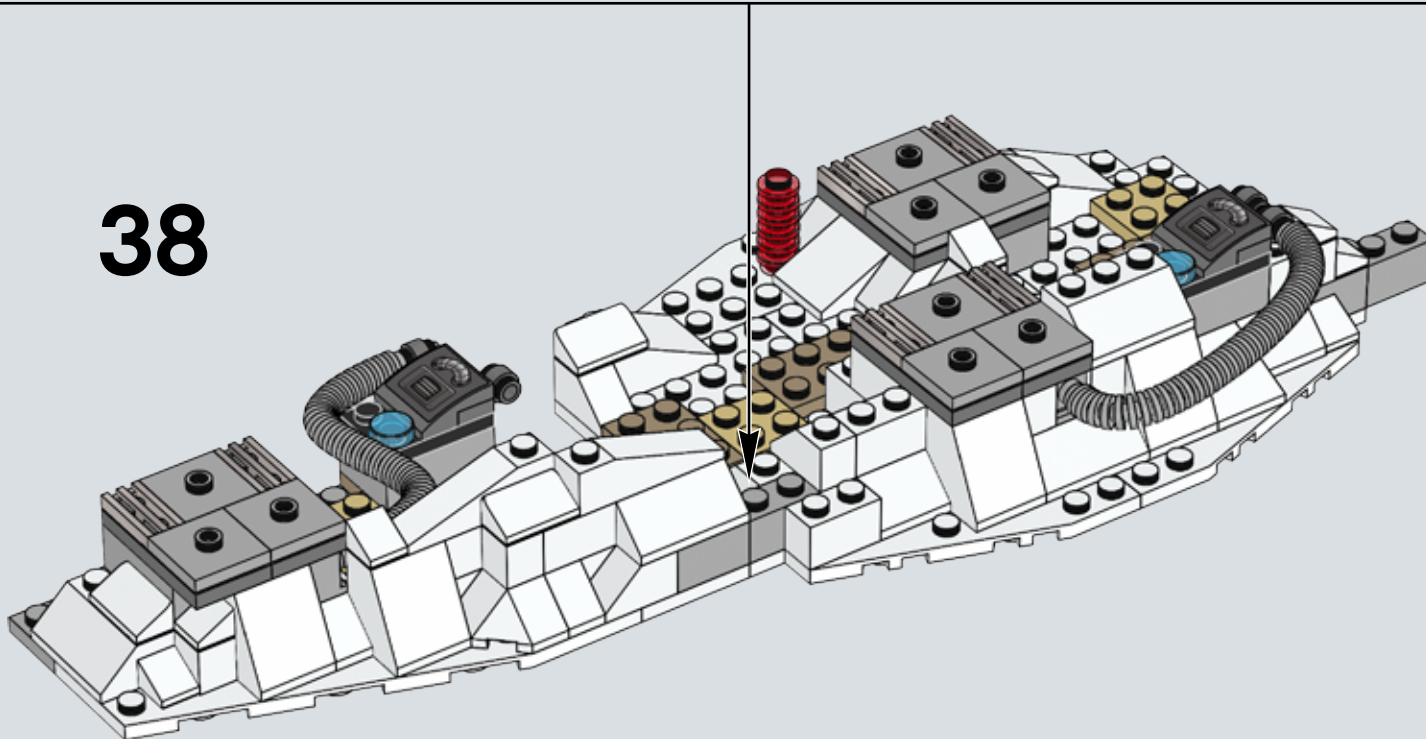



39

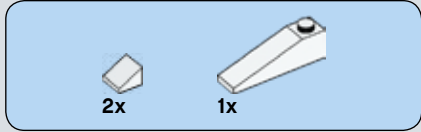
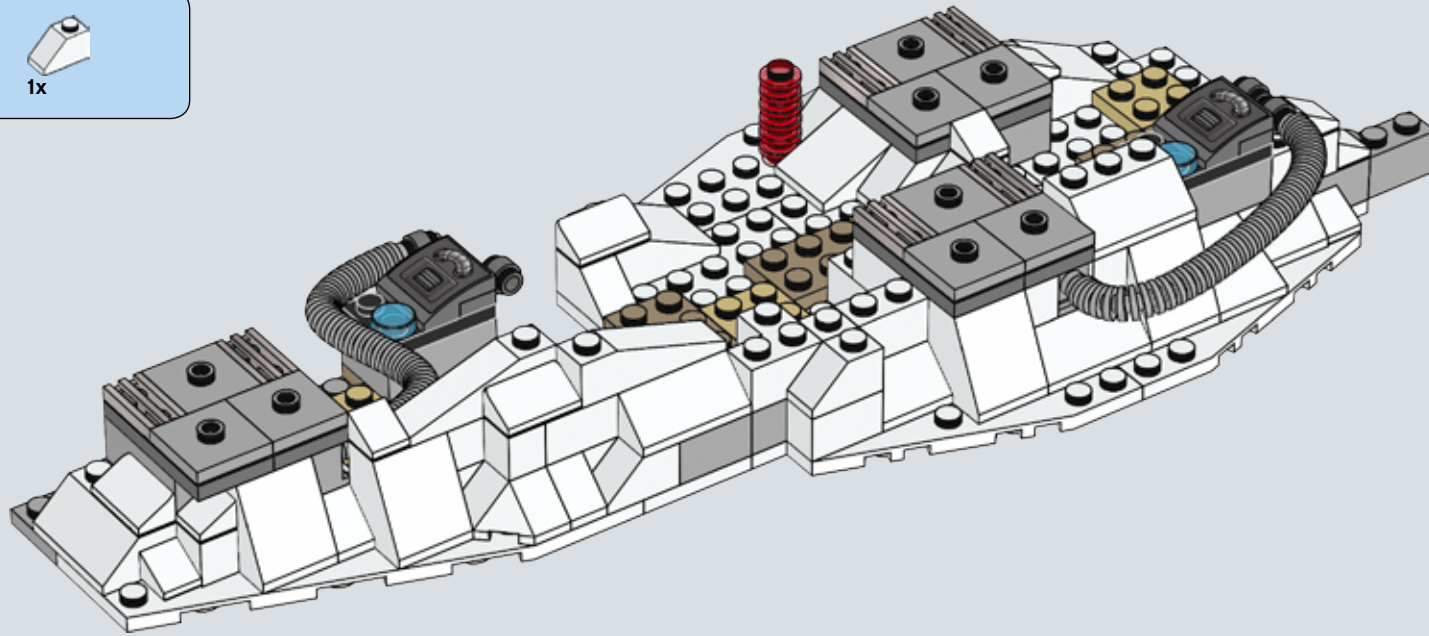

40

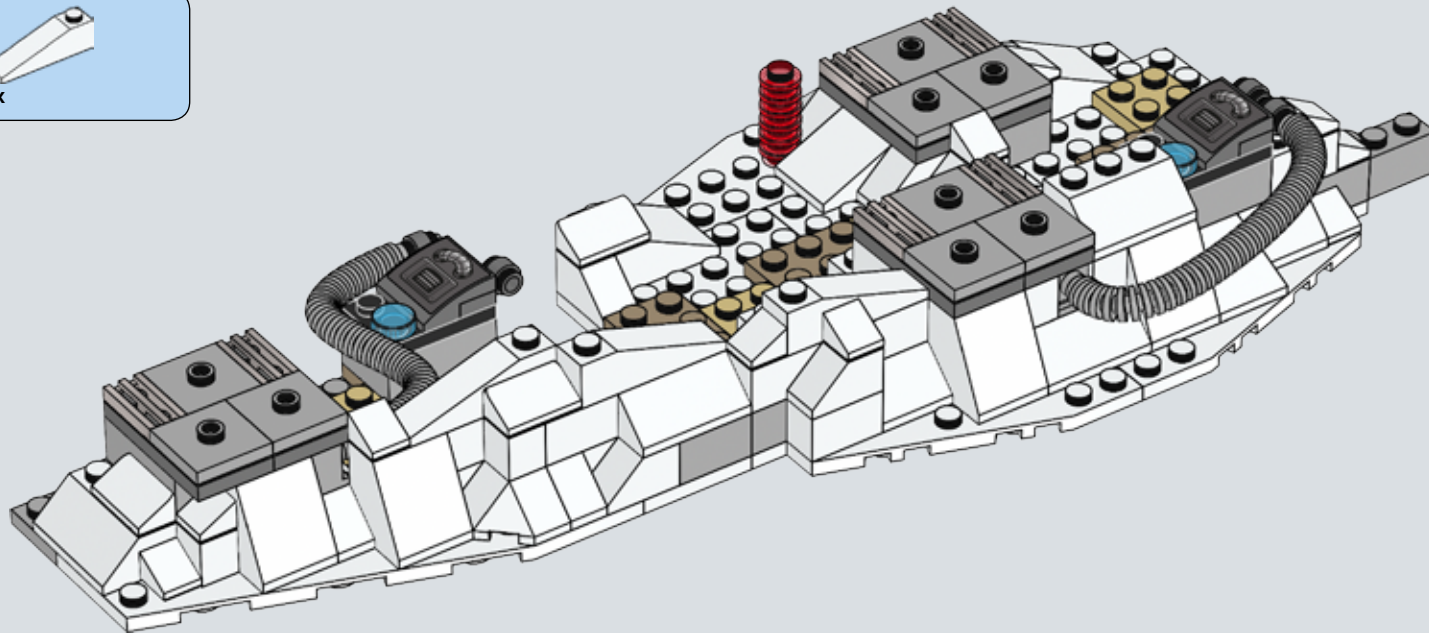



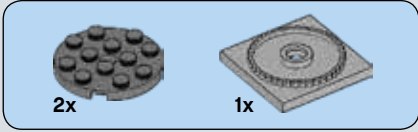

41

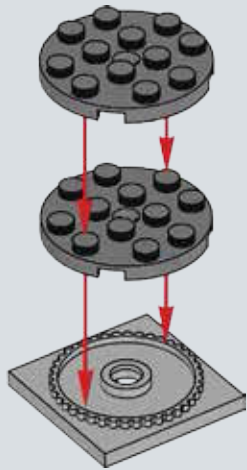

42

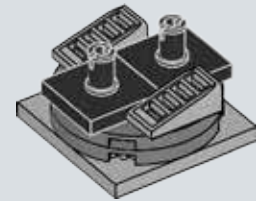

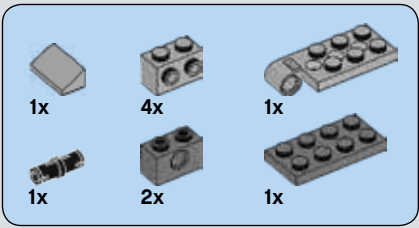

# 43

1

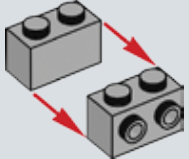

2

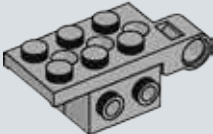

3

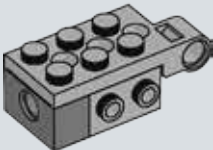

4

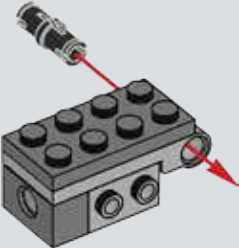

5

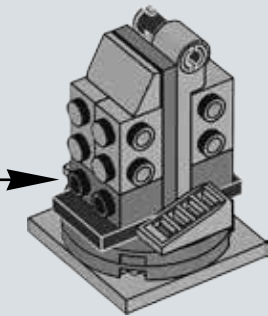
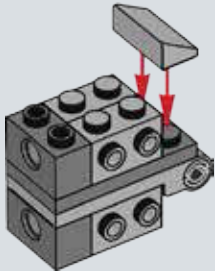

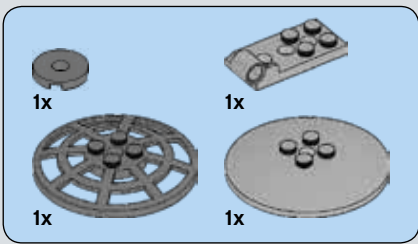

44

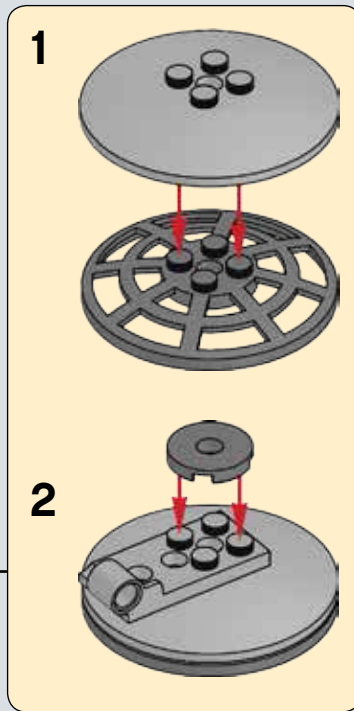
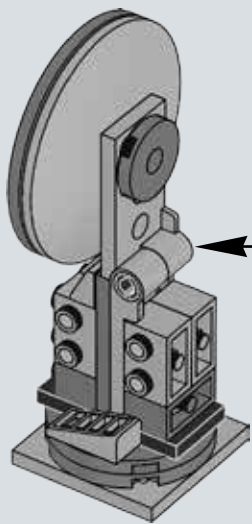

45

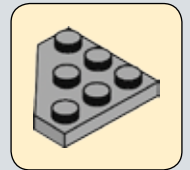
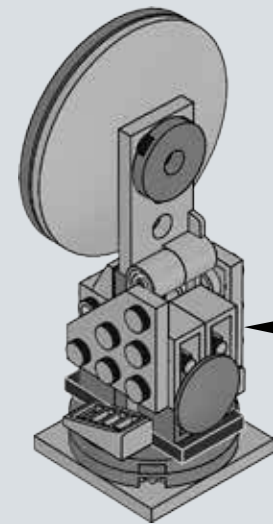



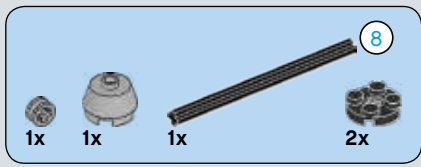

# 46

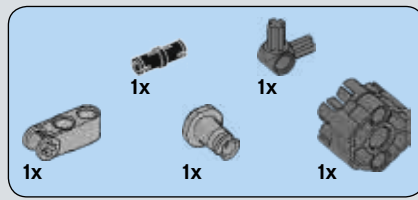
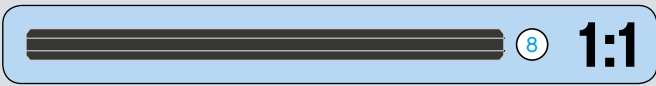
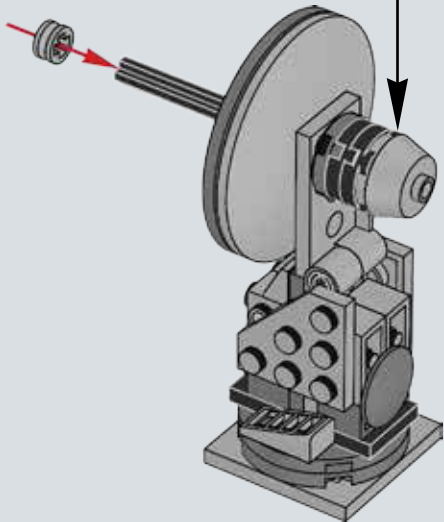
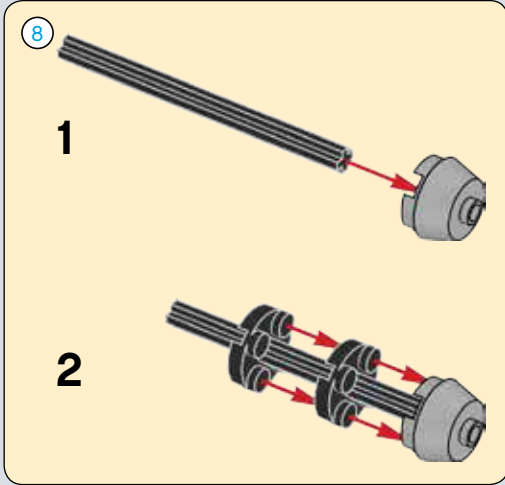

# 47

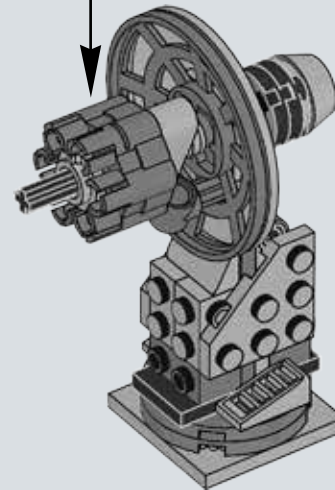
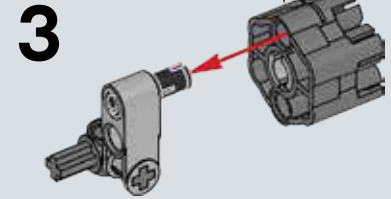
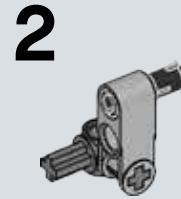
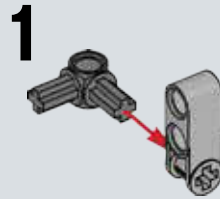
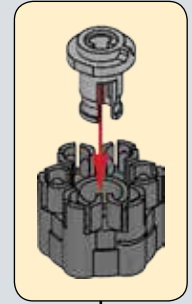

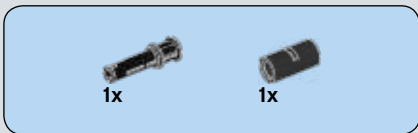

48

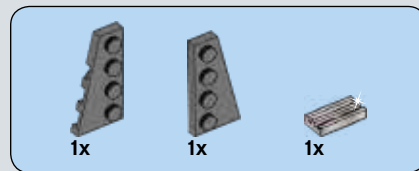
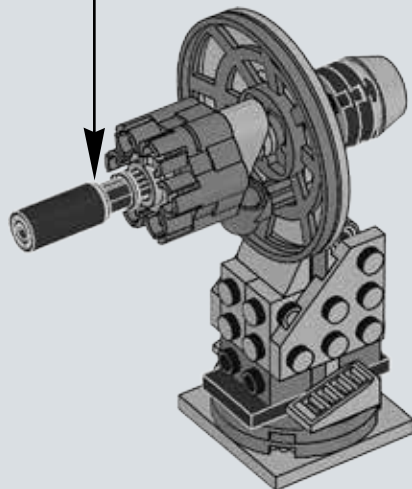
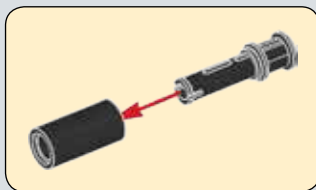

49

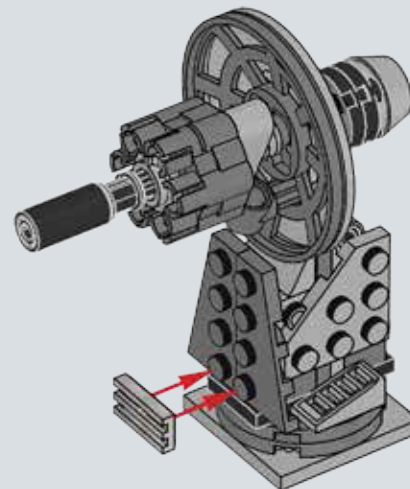



6x

50

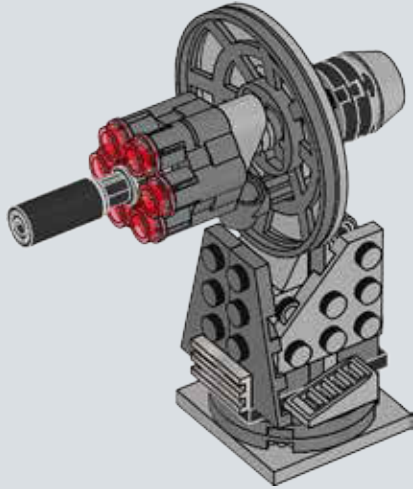

51

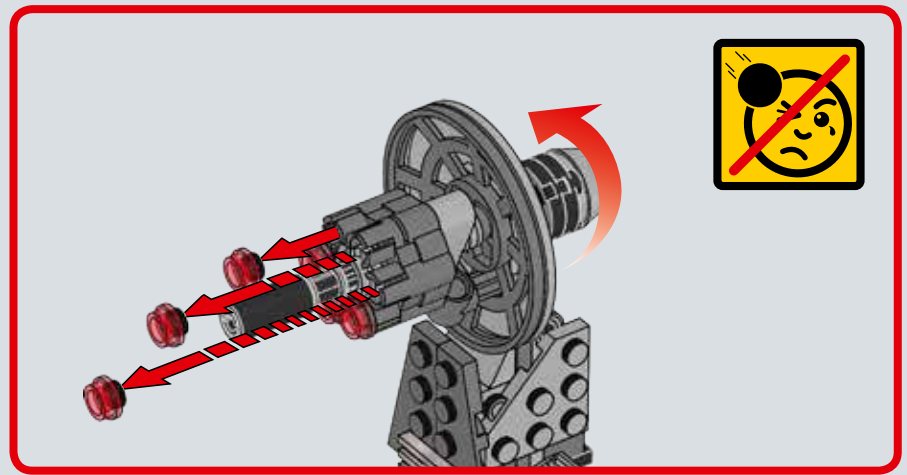
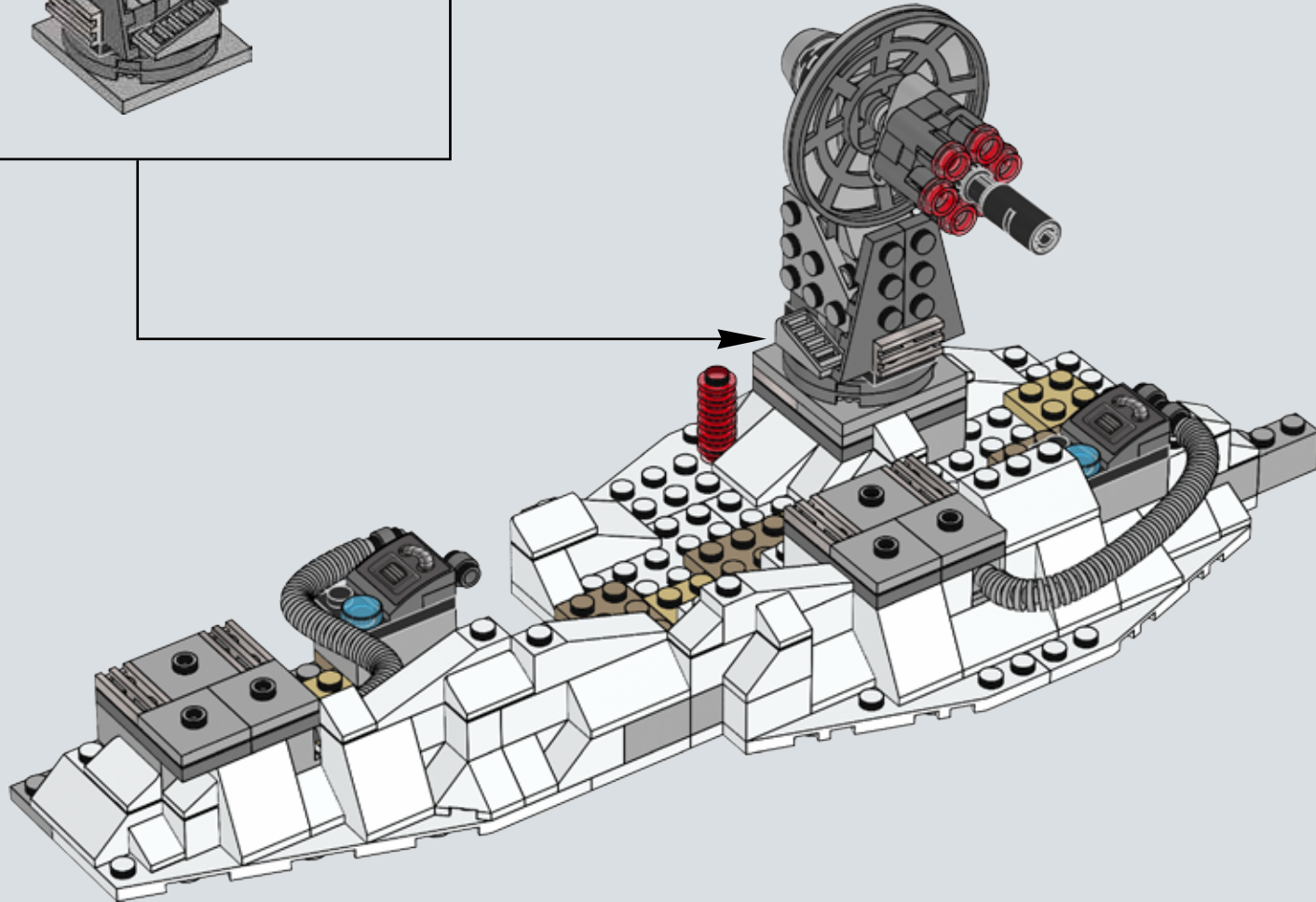



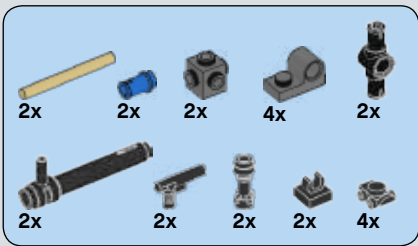

# 52

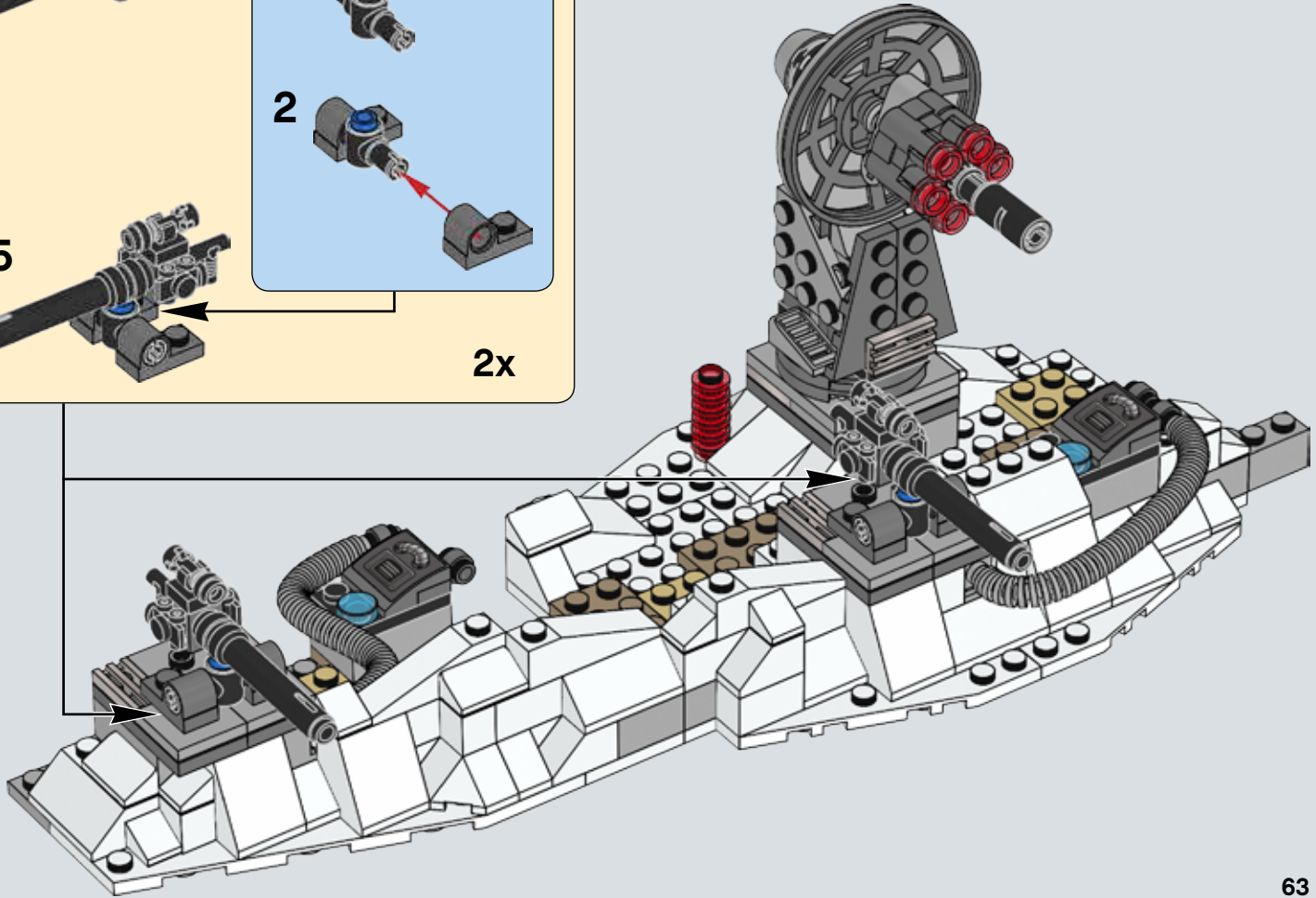
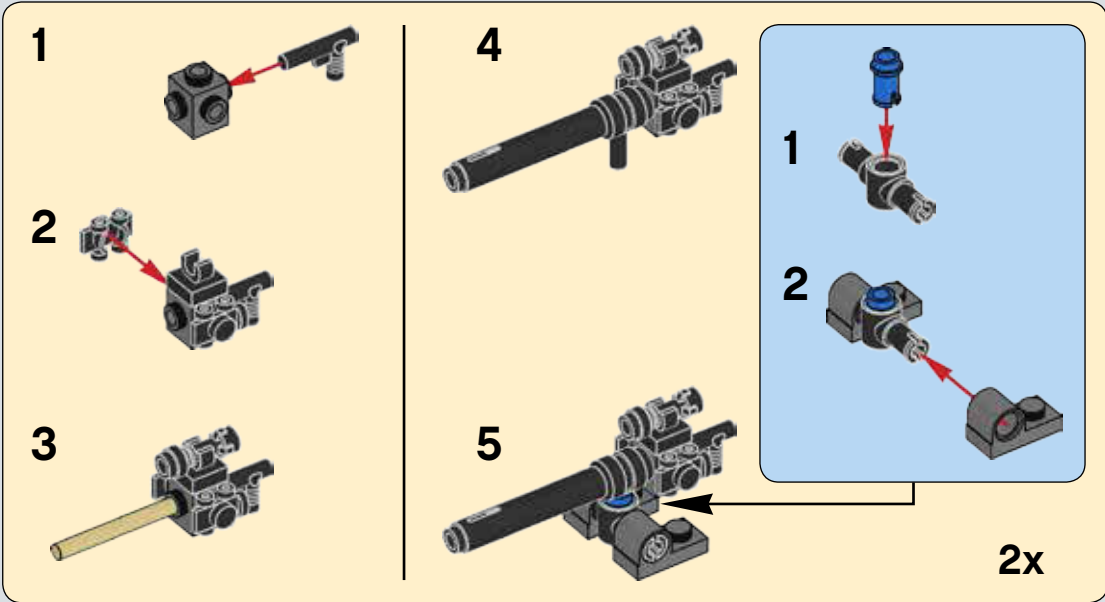

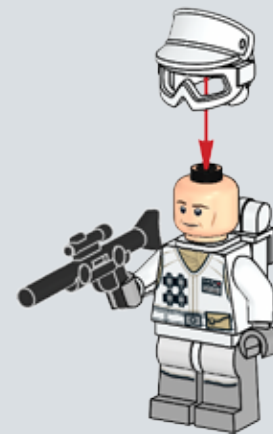
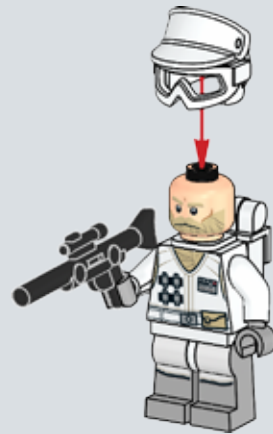
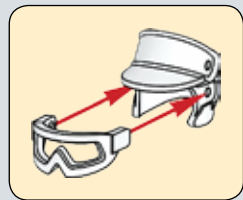
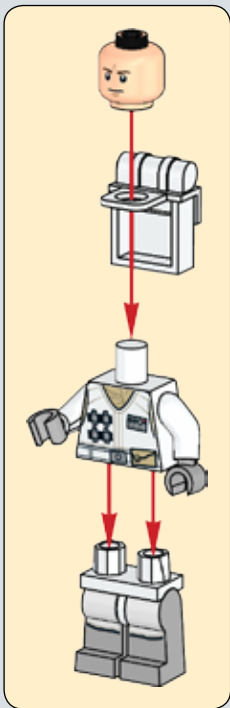
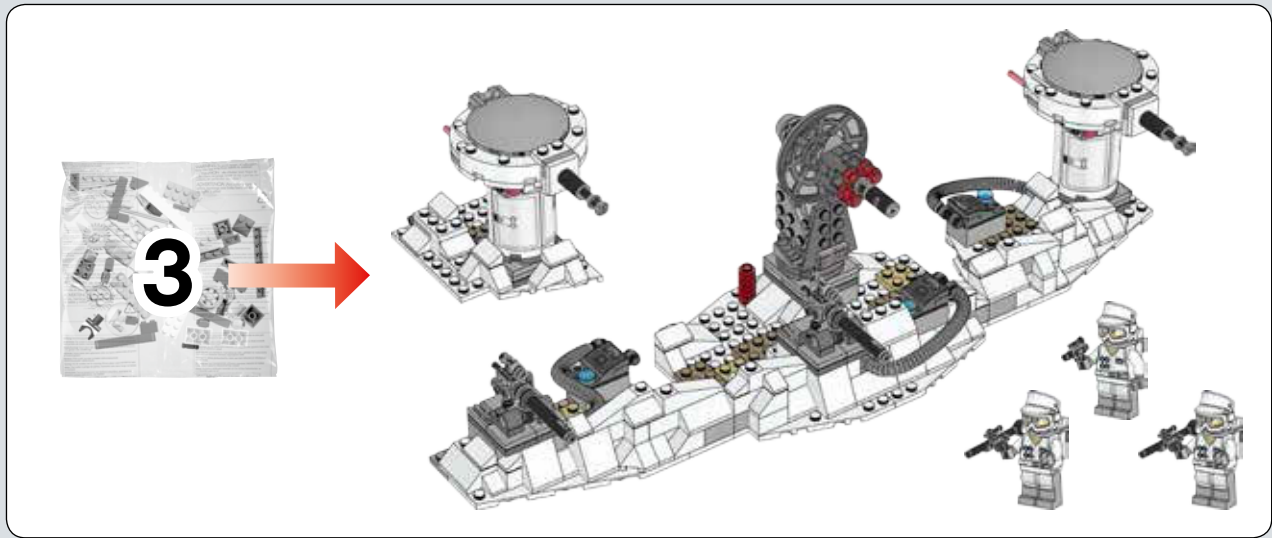

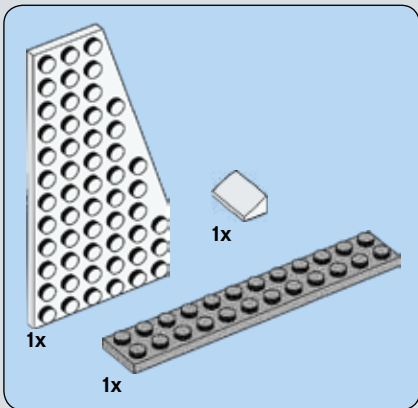
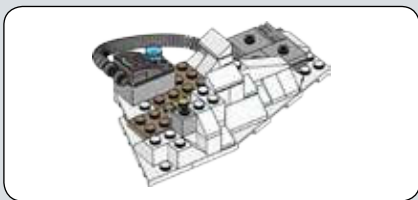

53

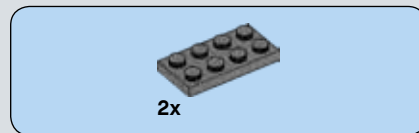
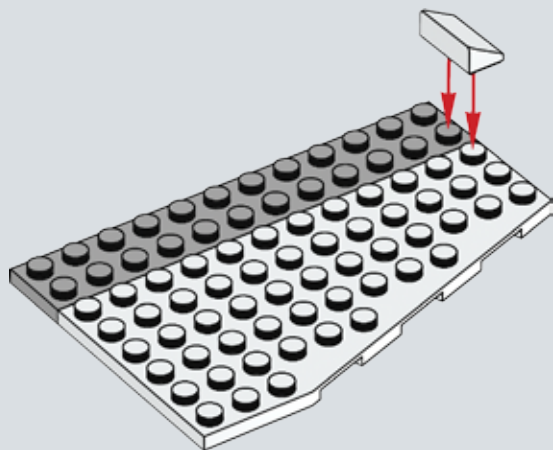

54





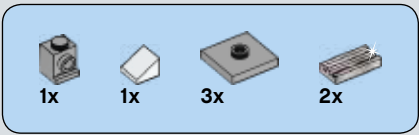

55

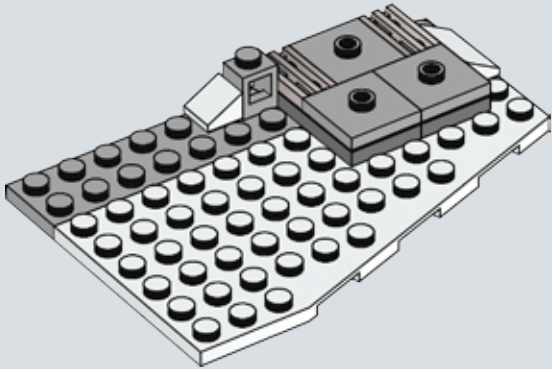

56

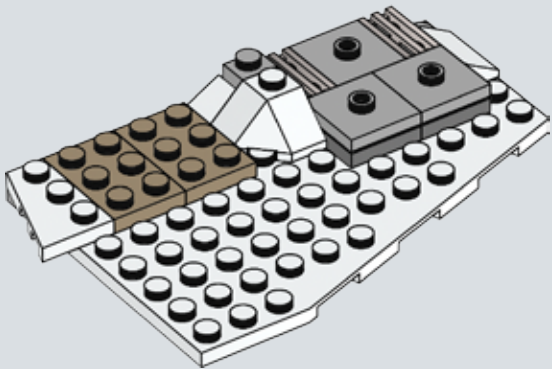

57

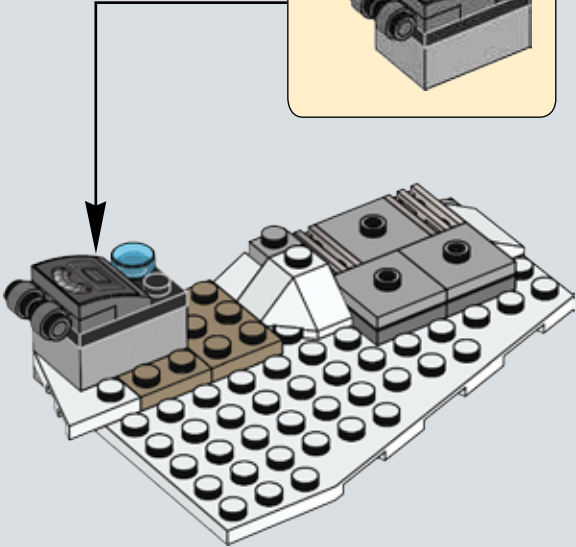
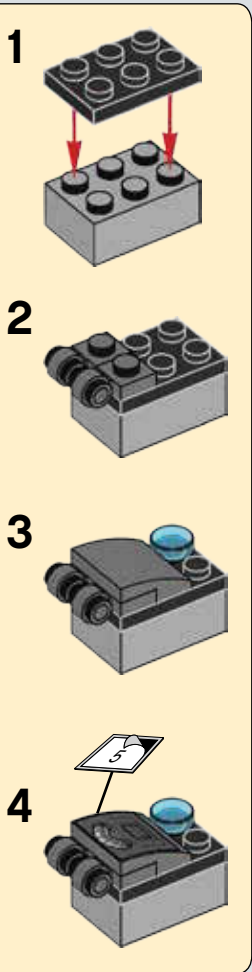

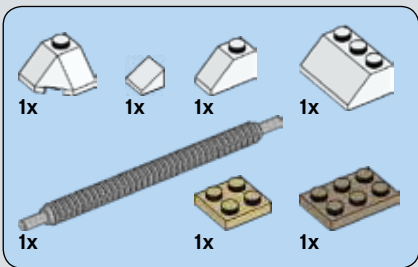

58

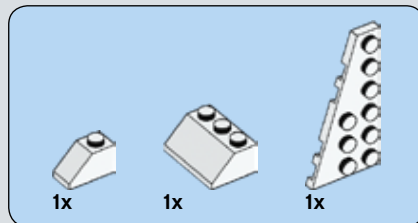
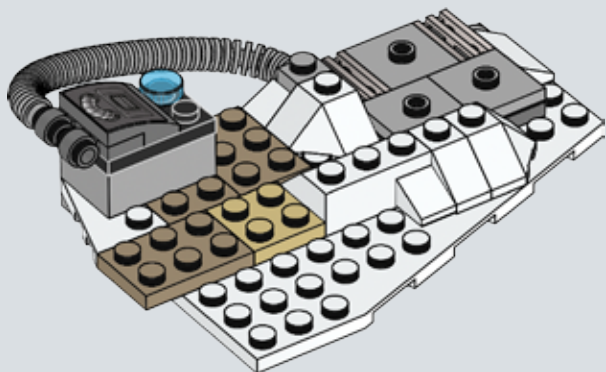

59

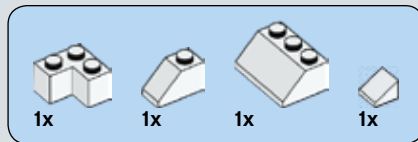
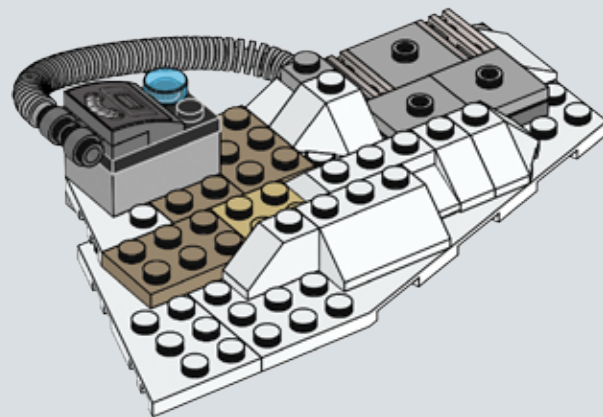

60

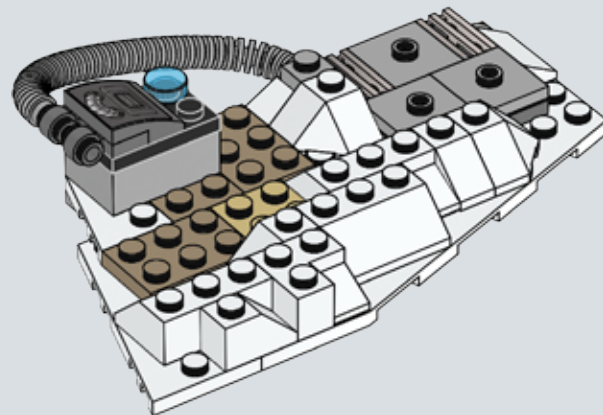

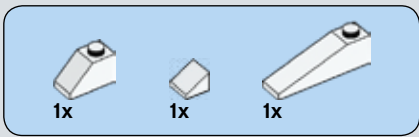

# 61

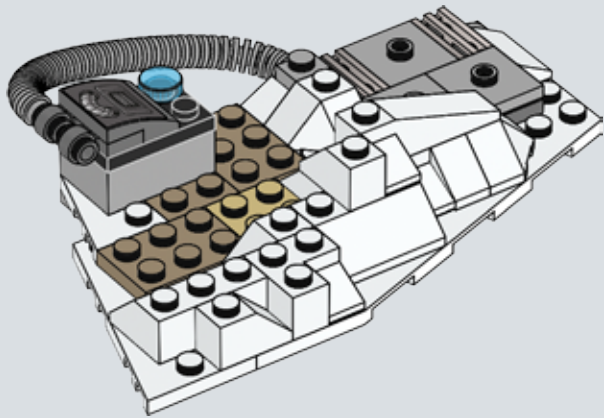

# 62

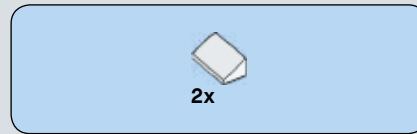
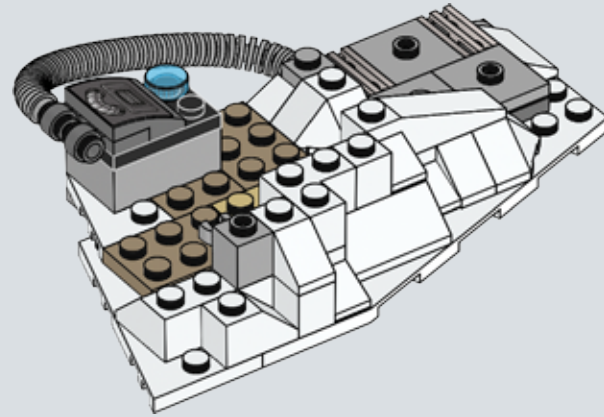

# 63

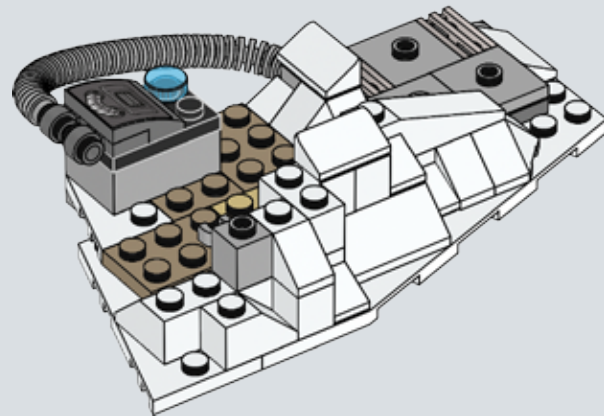



64

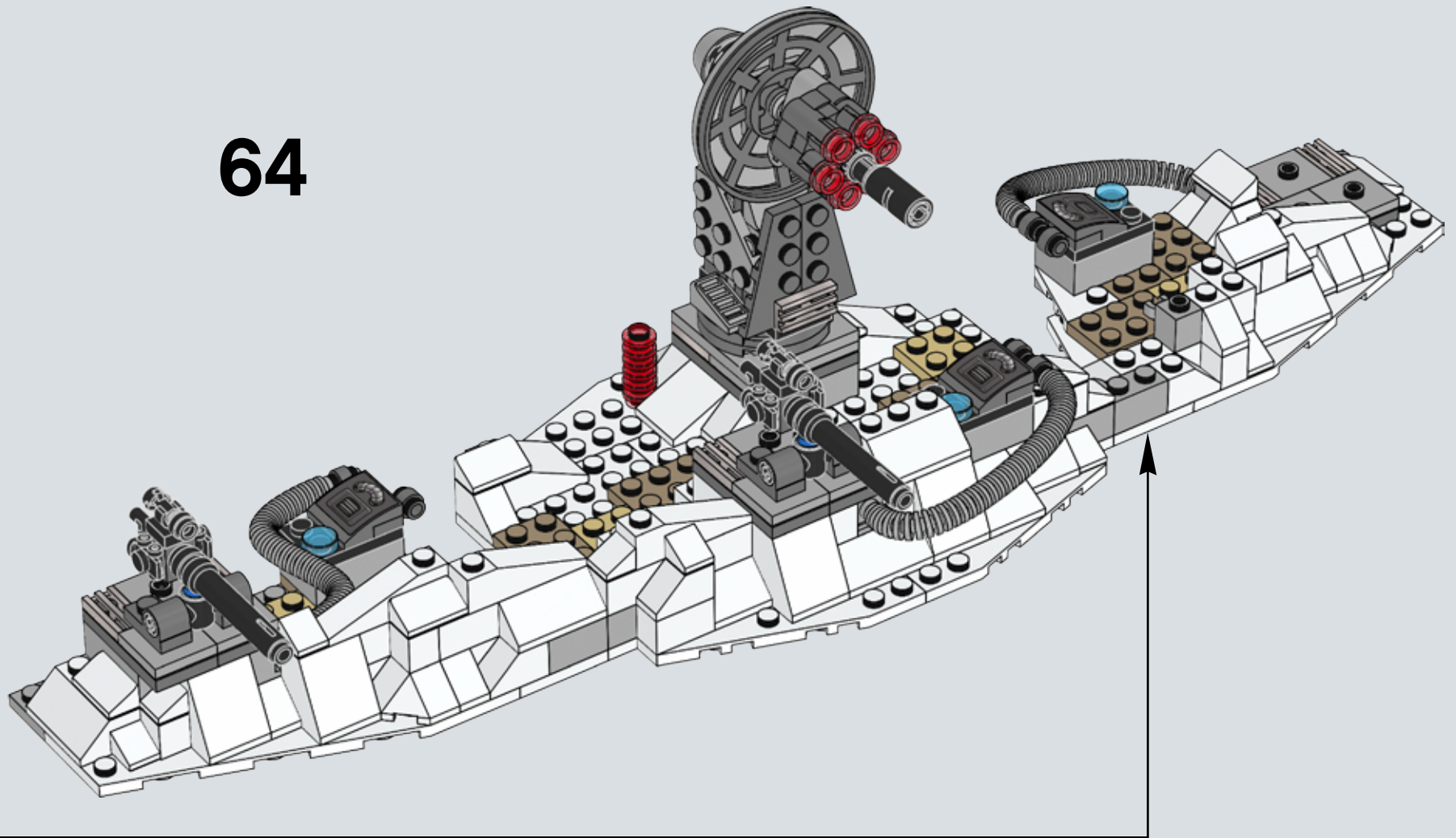

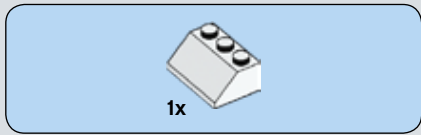

65

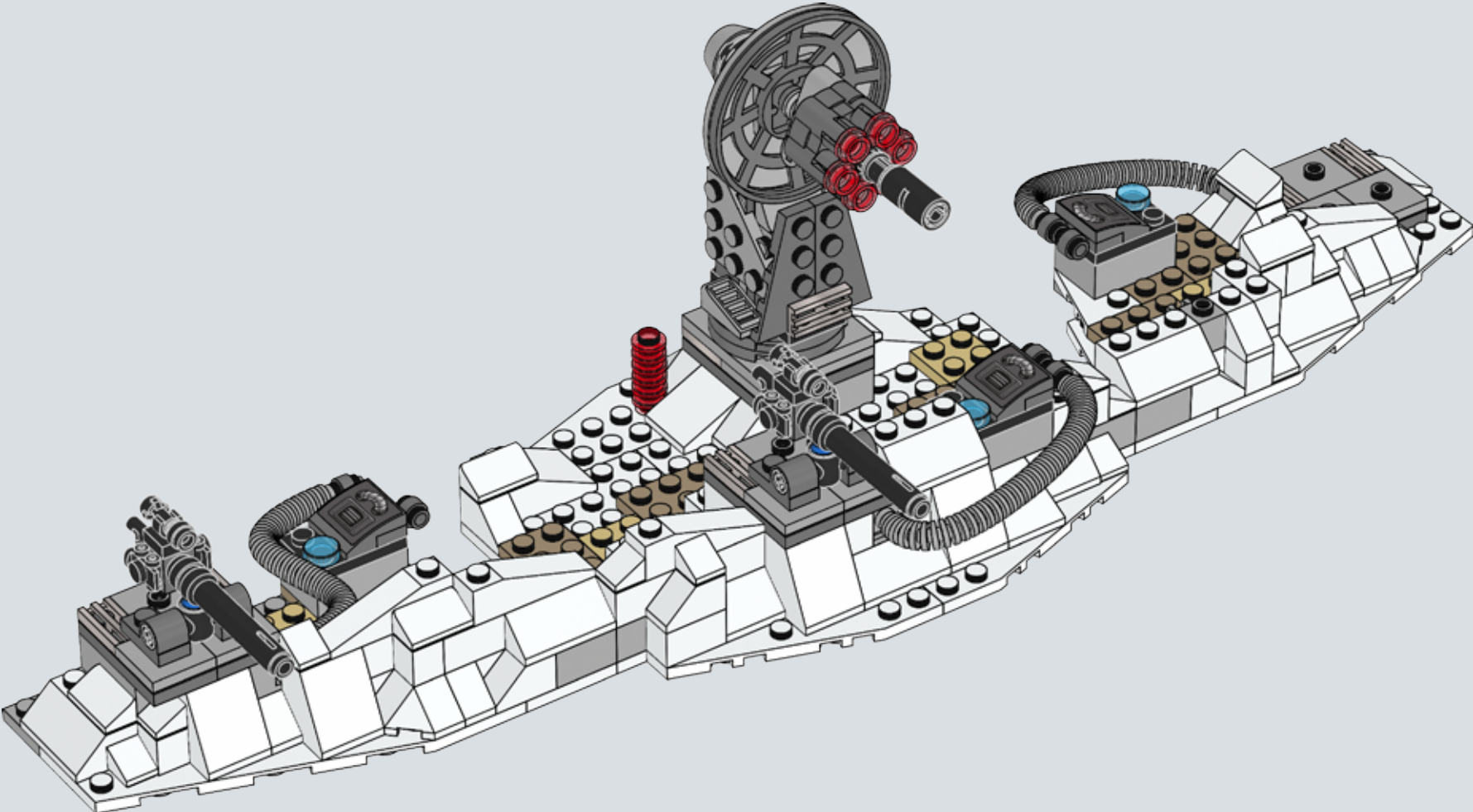

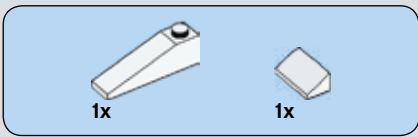

66

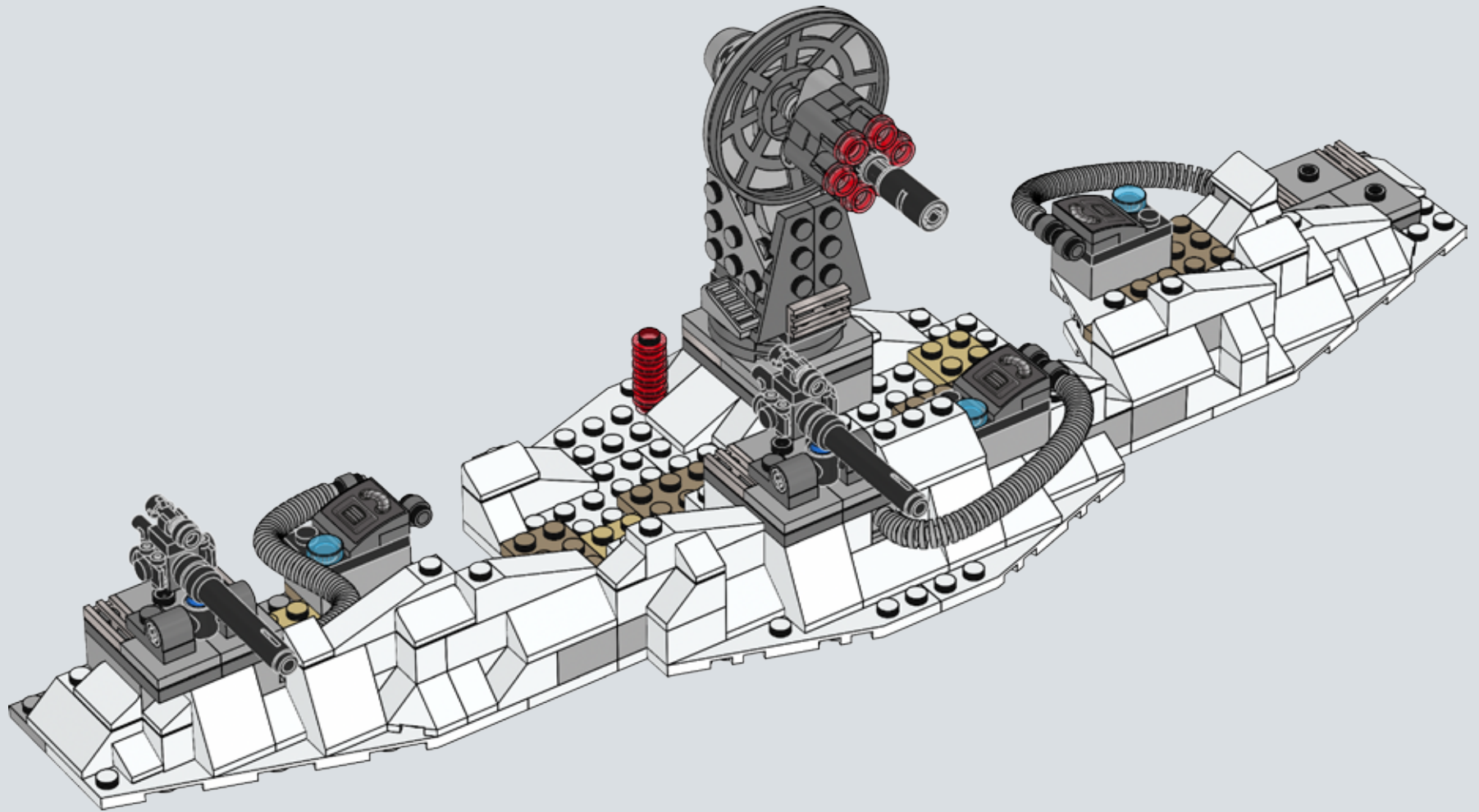



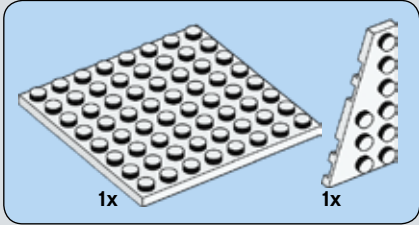
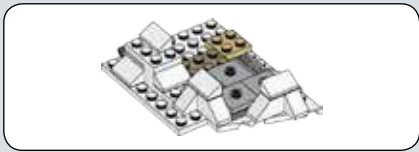

67

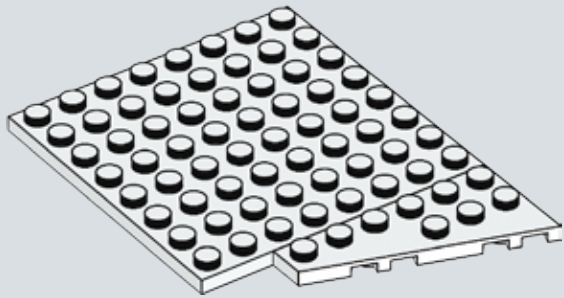

68

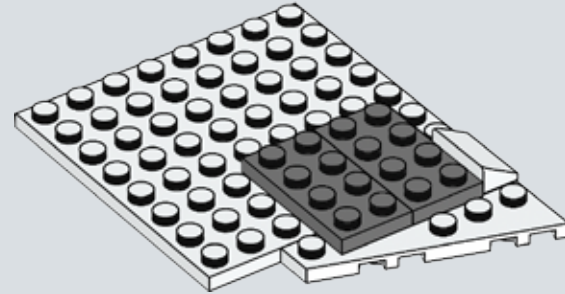

69

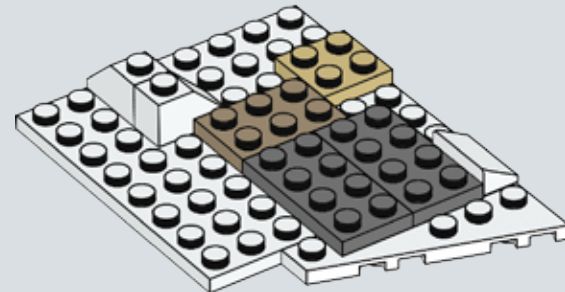

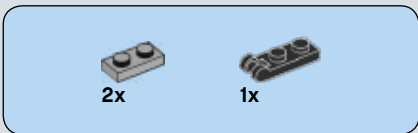

# 70

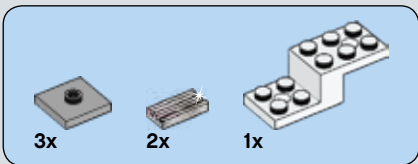
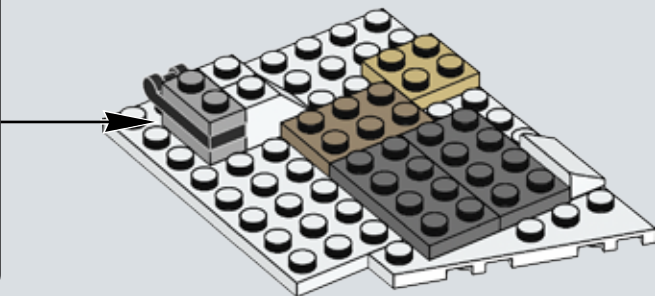
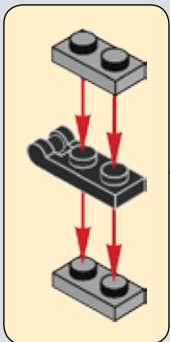

# 71

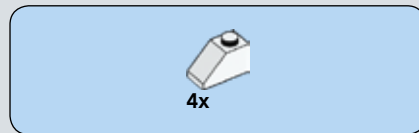
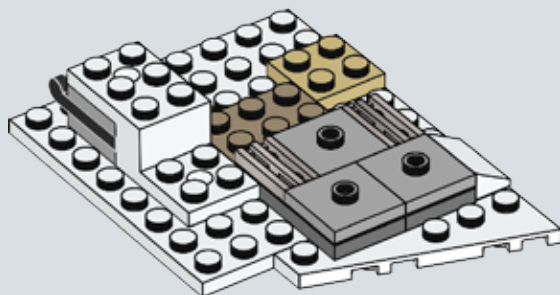

# 72

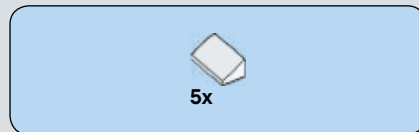
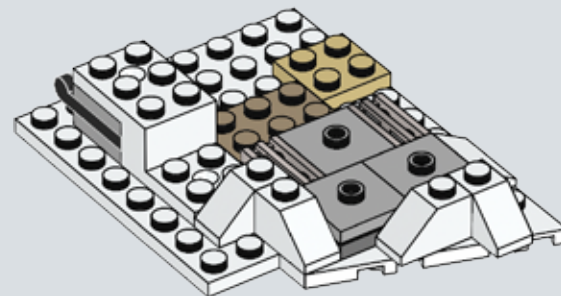

# 73

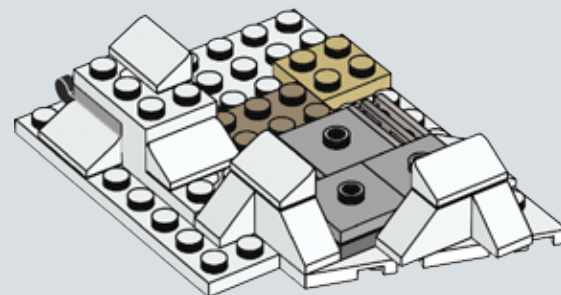

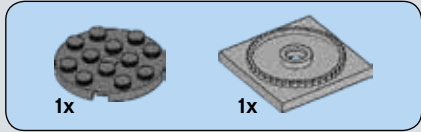

74

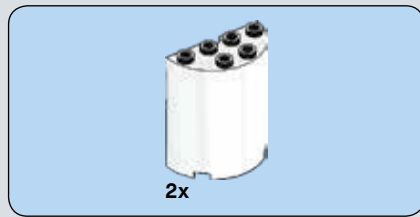
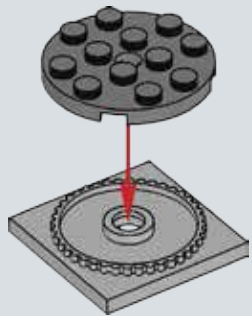

75

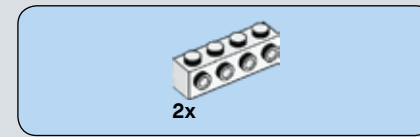
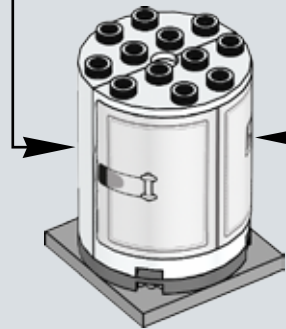
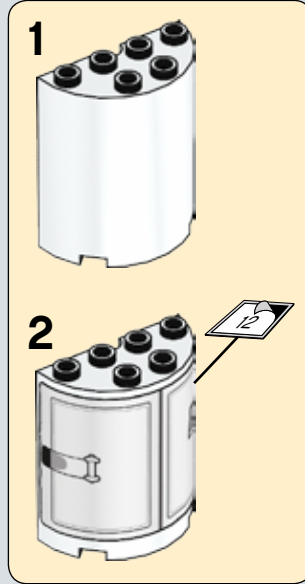
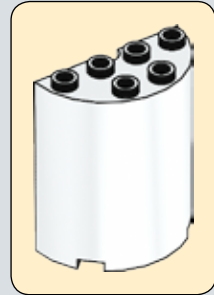

76

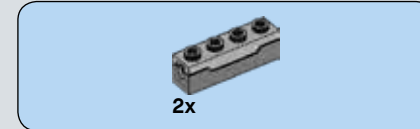
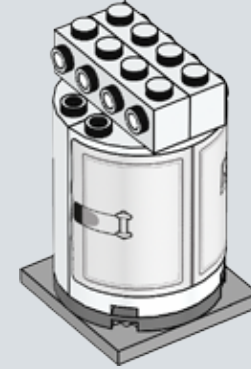

77

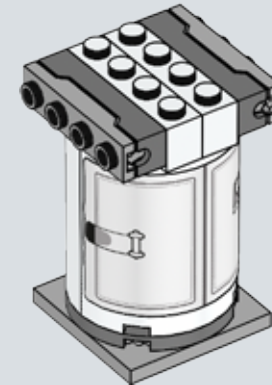



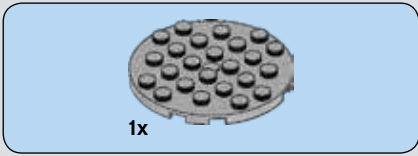

78

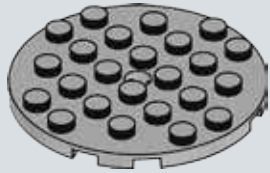

79

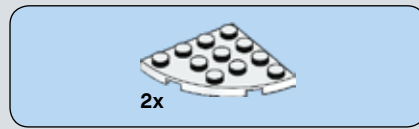
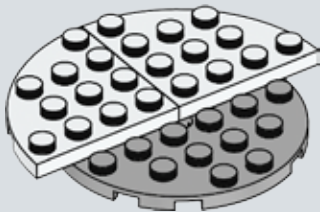

80

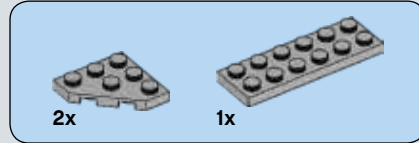
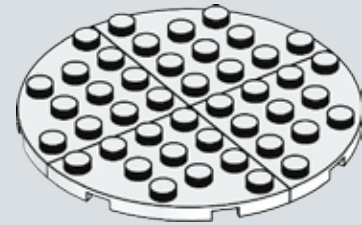

81

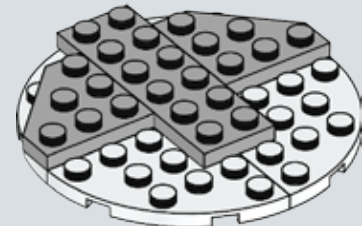

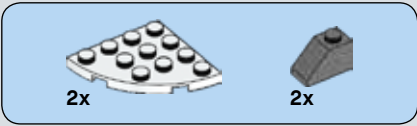

# 82

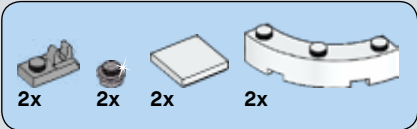
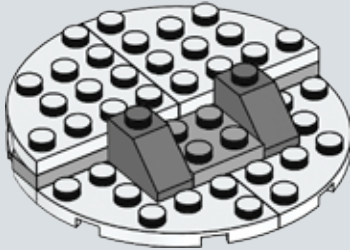

# 83

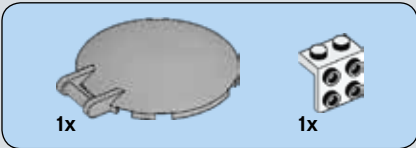
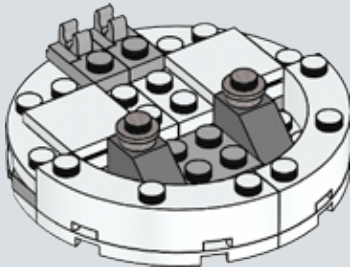

# 84

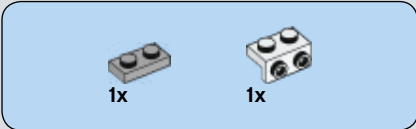
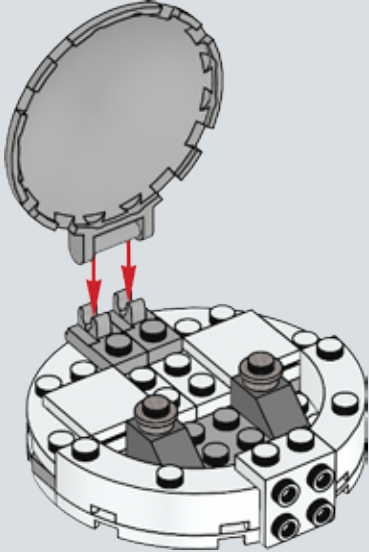

# 85

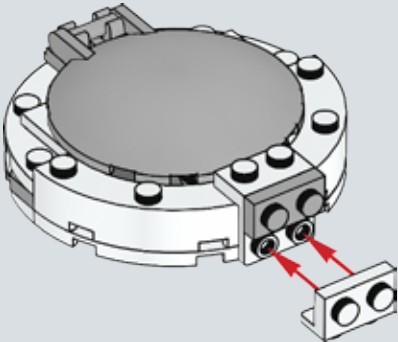

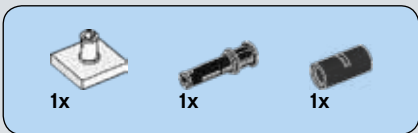

86

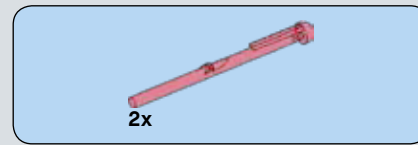
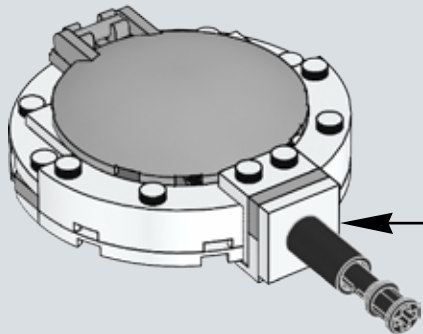
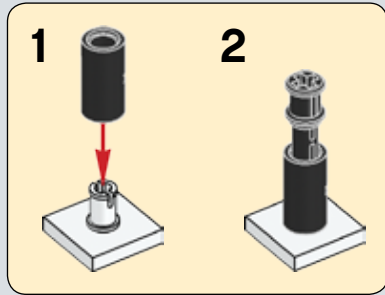

88

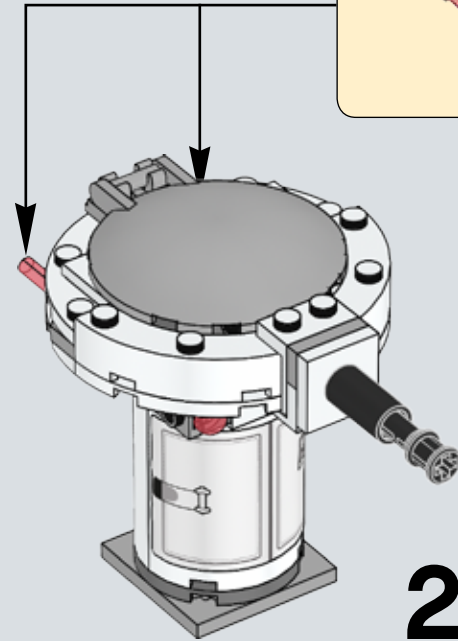
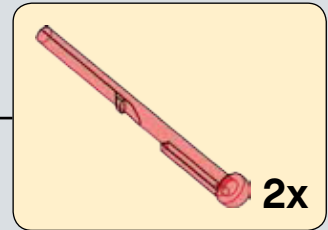

2x

87

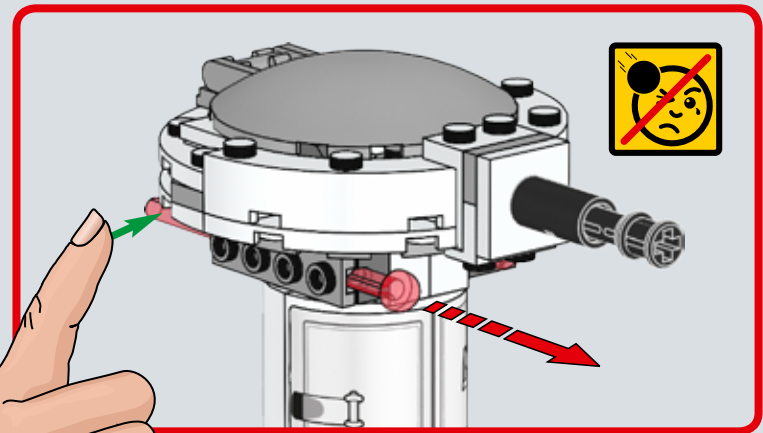
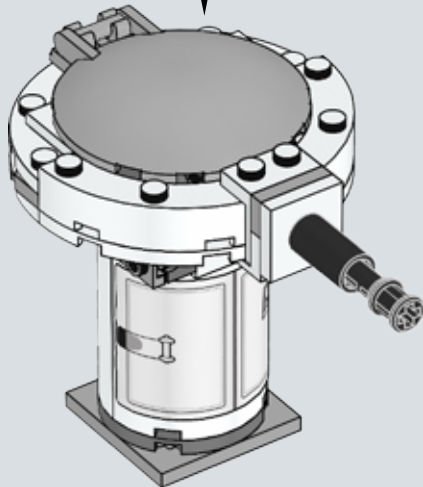



89

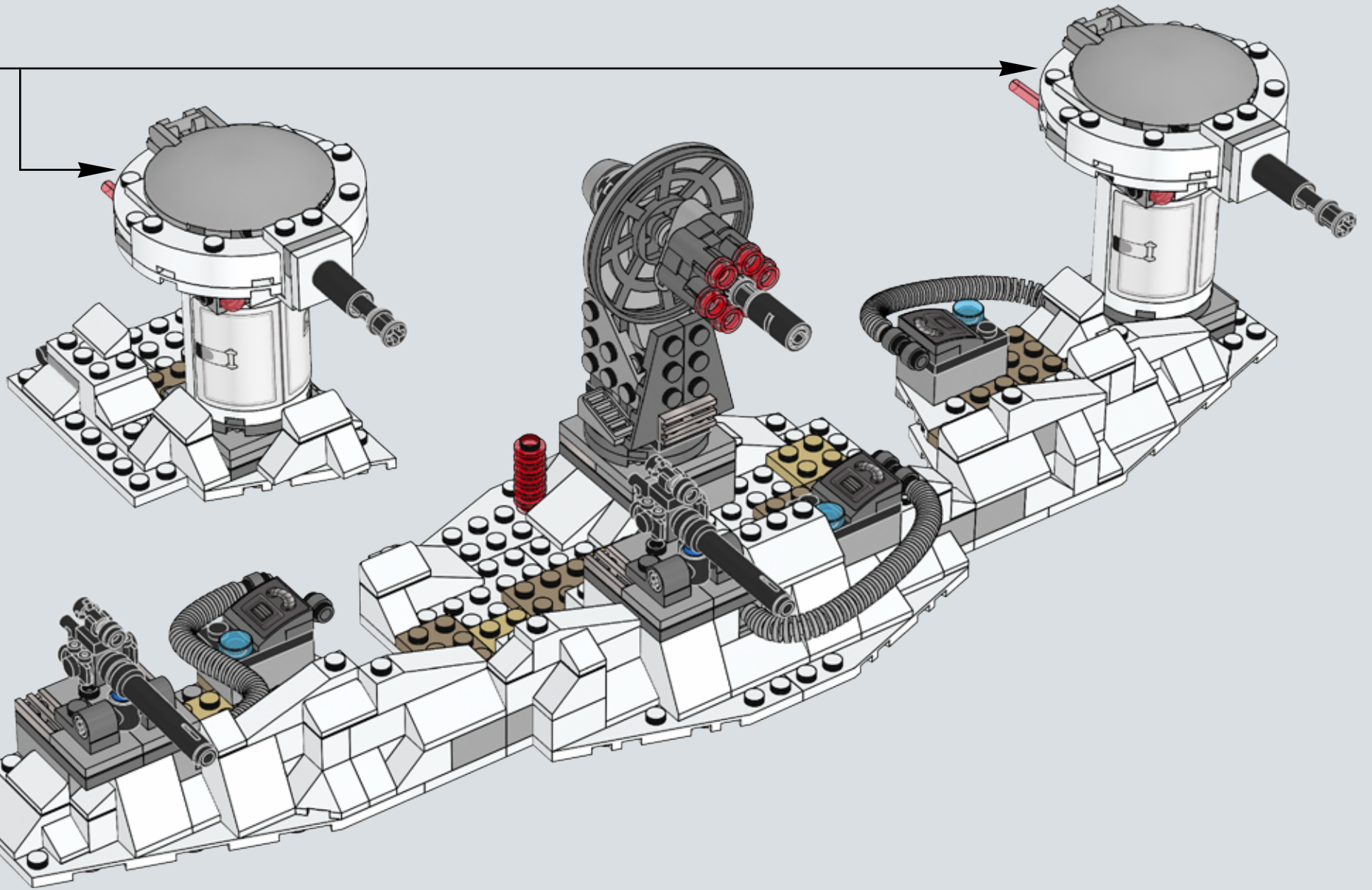

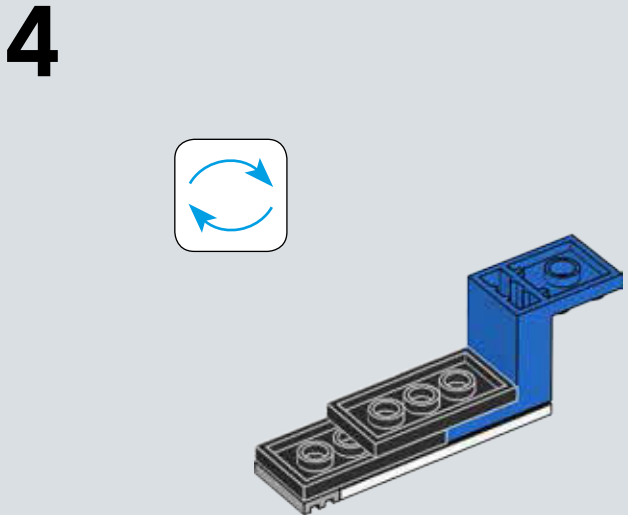
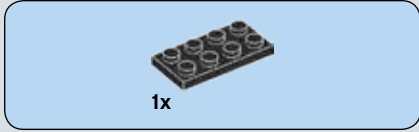
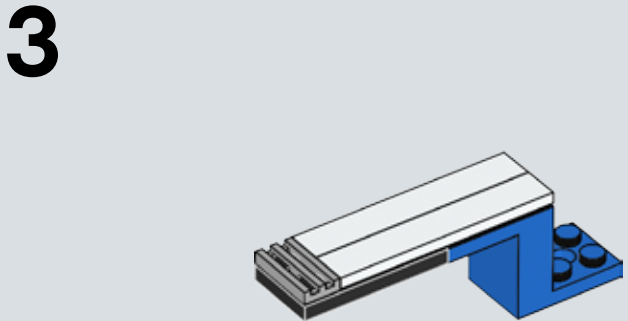
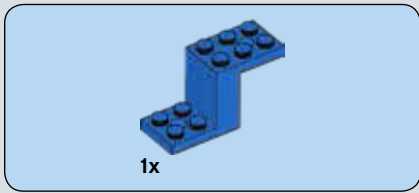
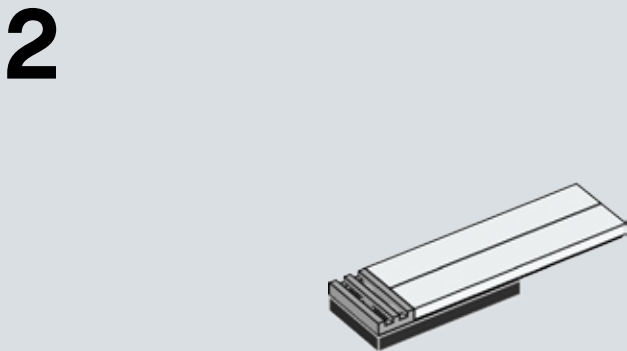
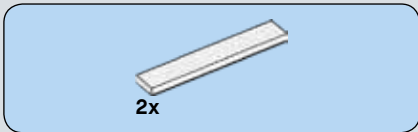
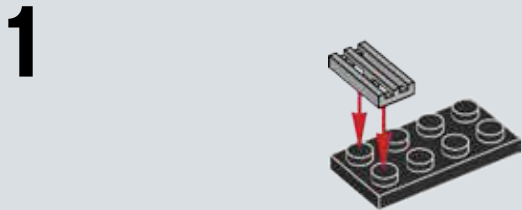
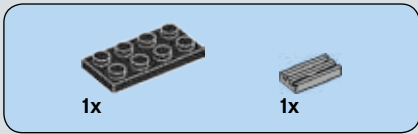
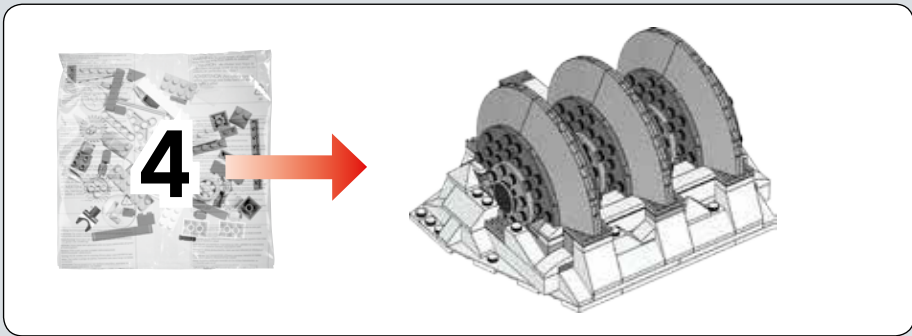



2x

5

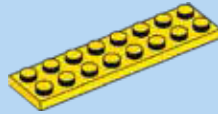
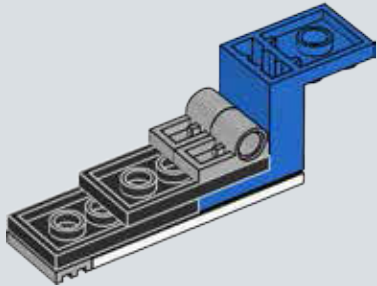

1x

6

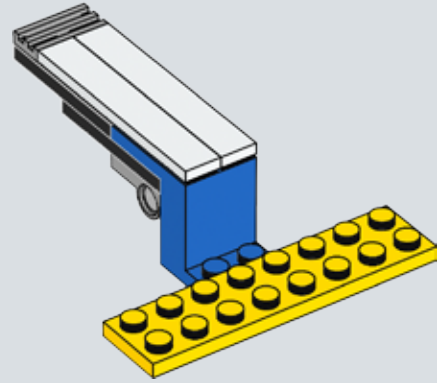
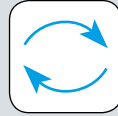

1x

7

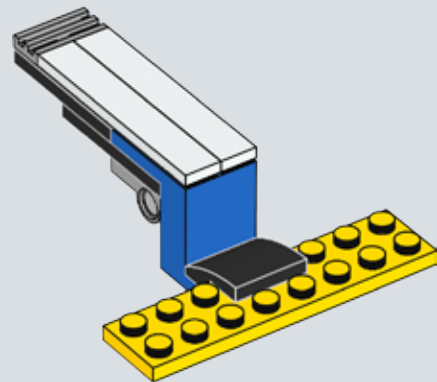



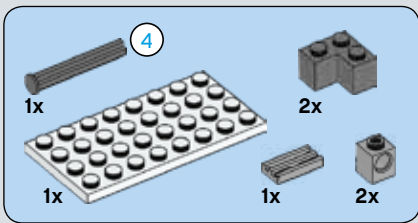

8

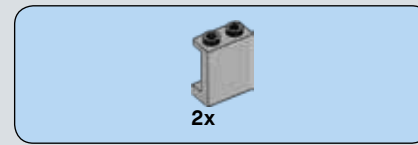
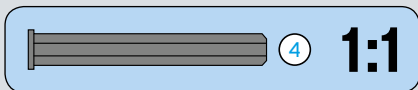
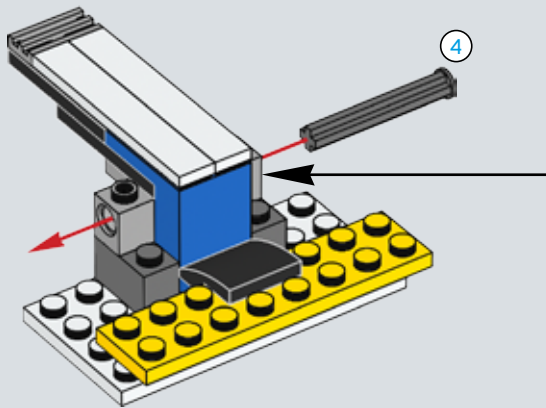
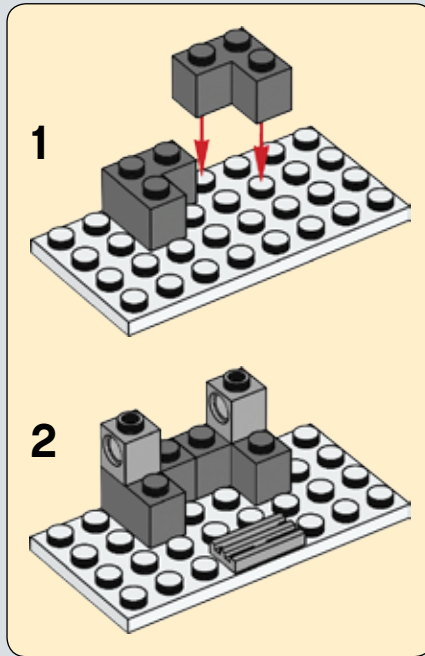

9

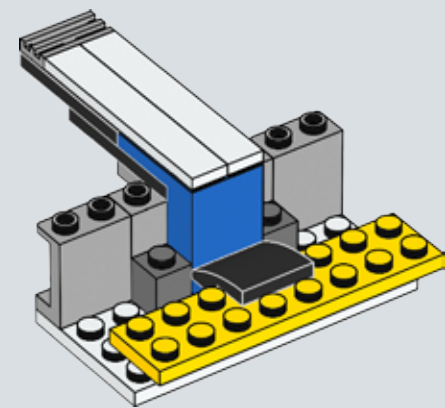

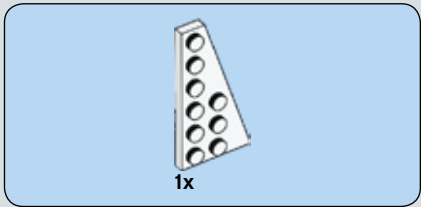
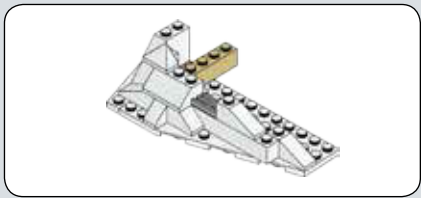

10

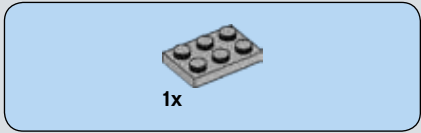
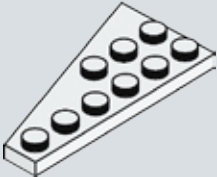

11

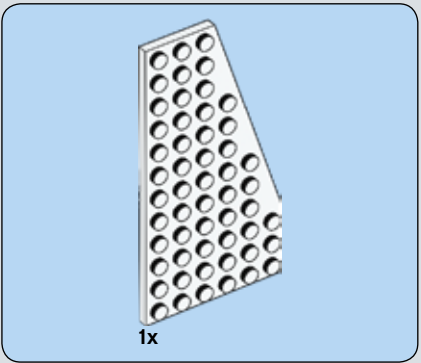
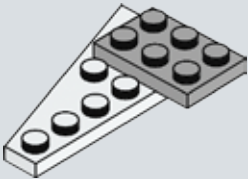

12

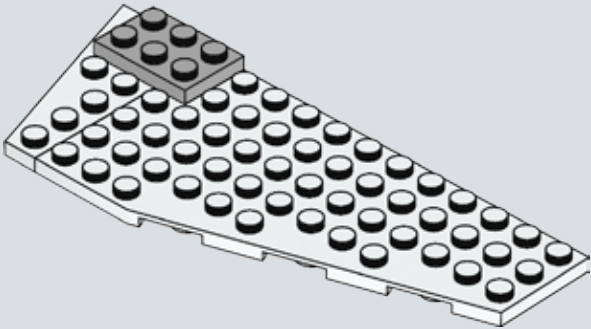



13

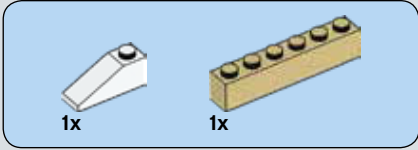
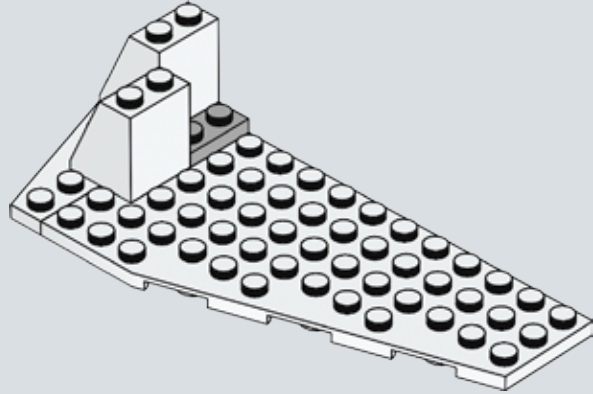

14

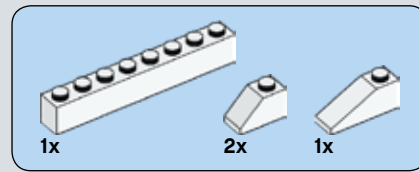
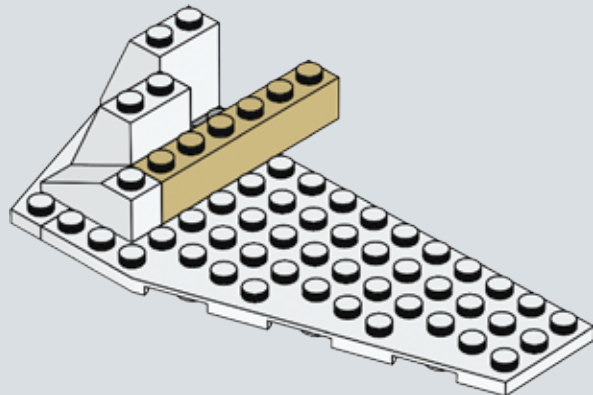

15

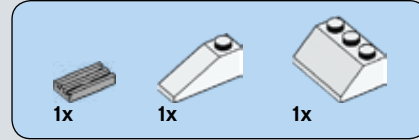
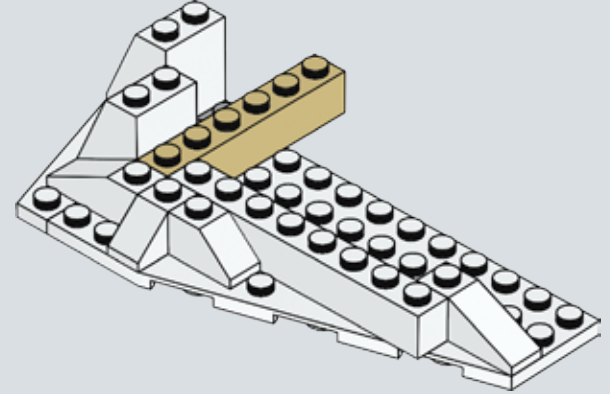

16

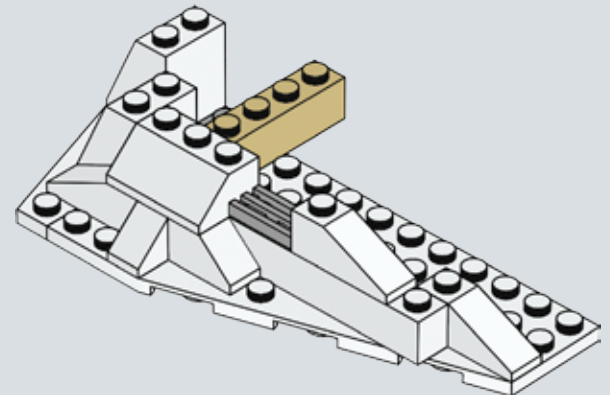





1x

# 17

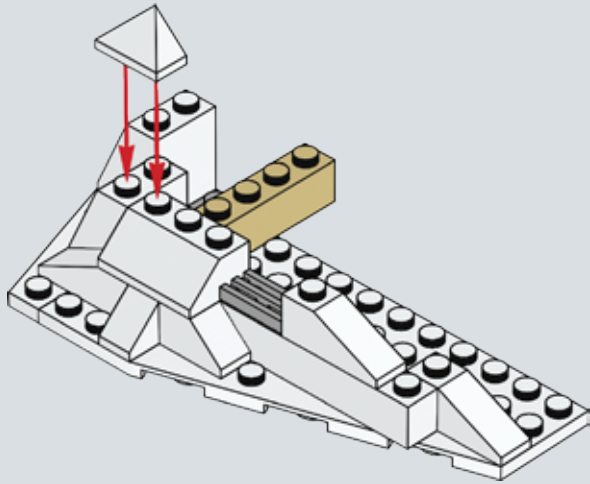

# 18

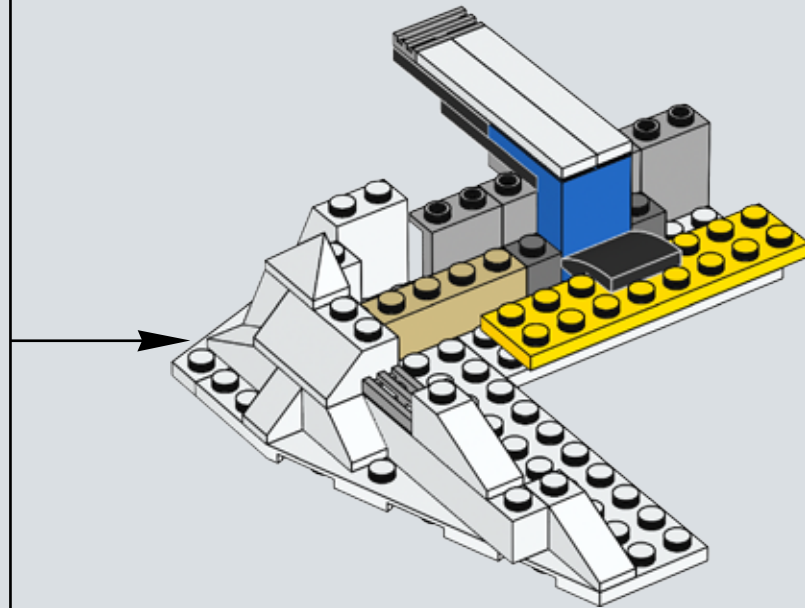

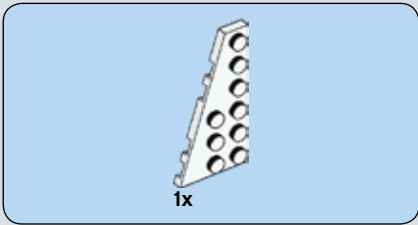
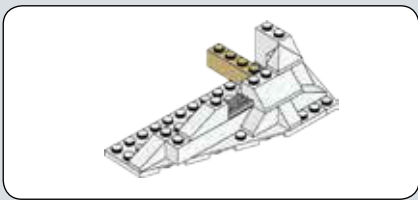

19

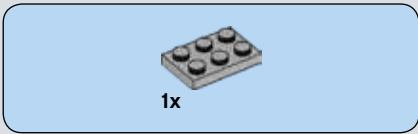
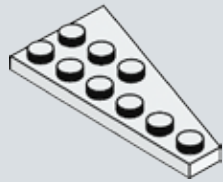

20

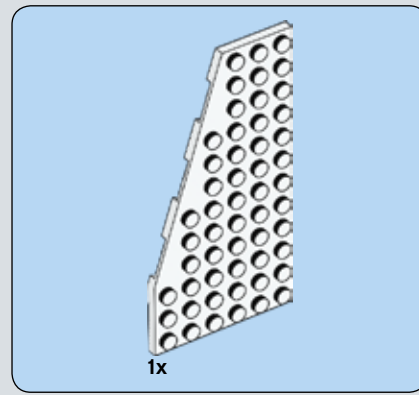
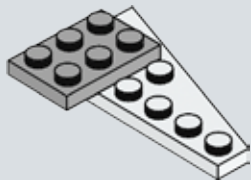

21

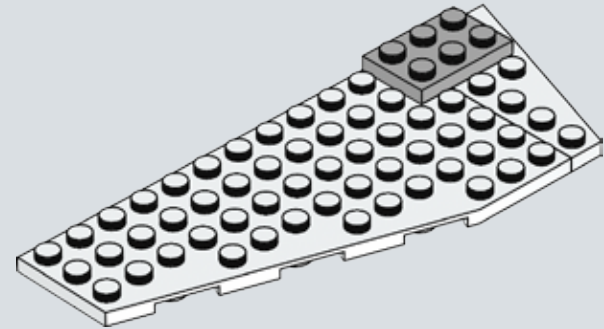



22

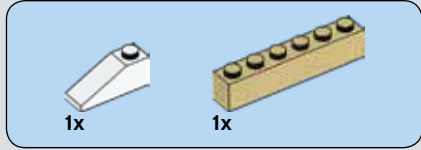
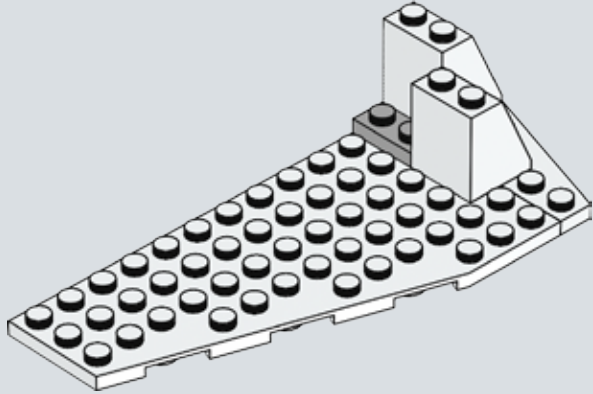

23

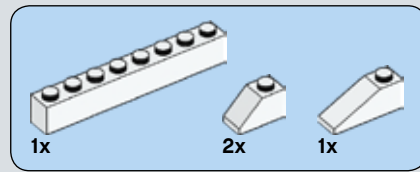
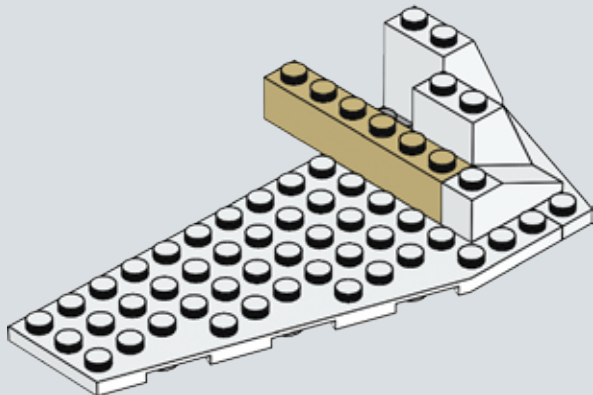

24

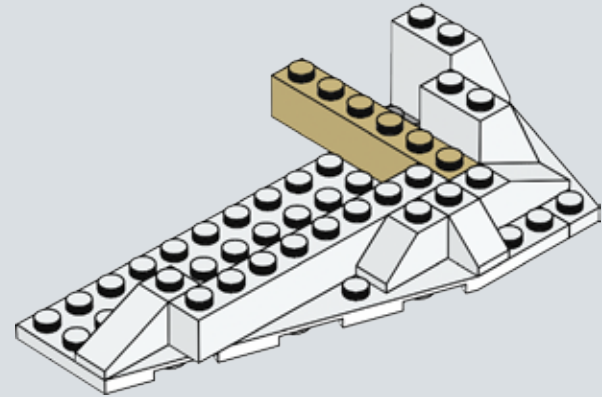



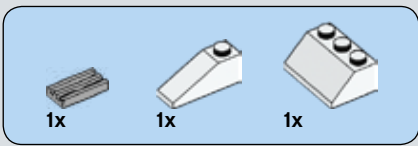

25

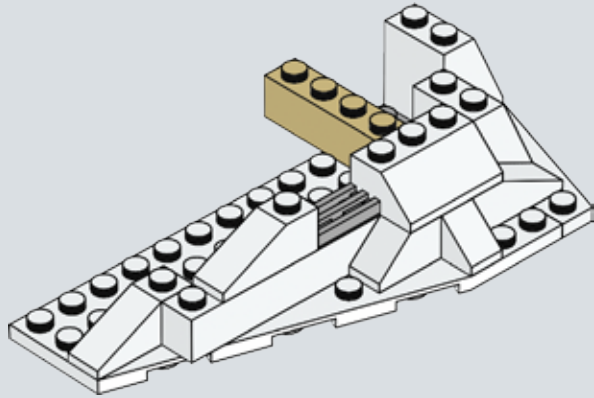

26

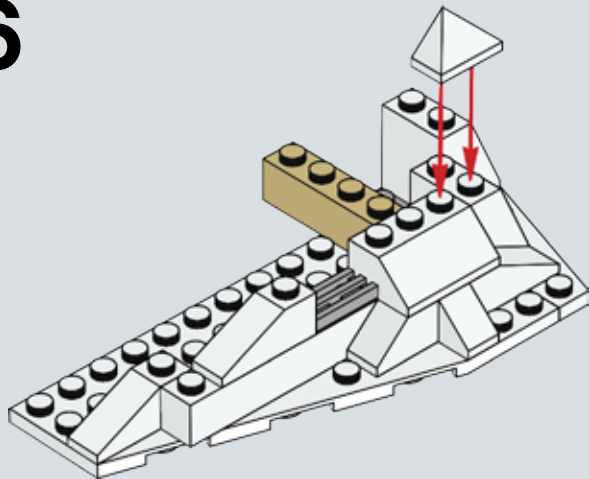

27

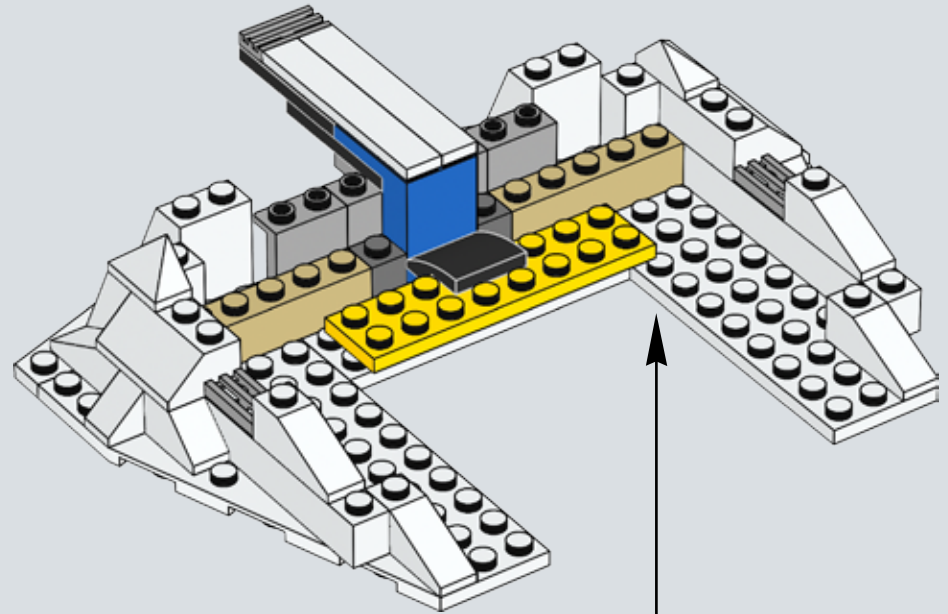



4x

# 28

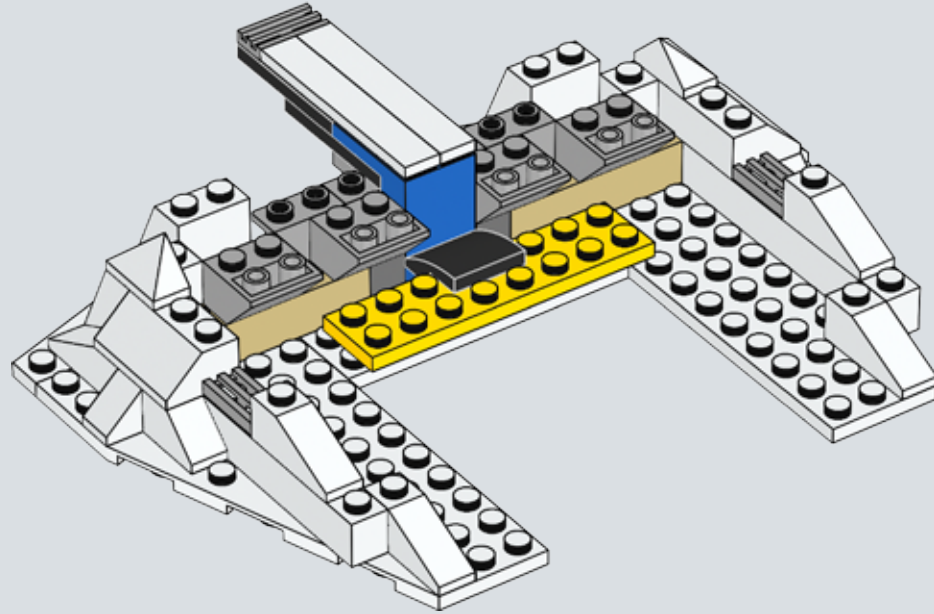

2x

# 29

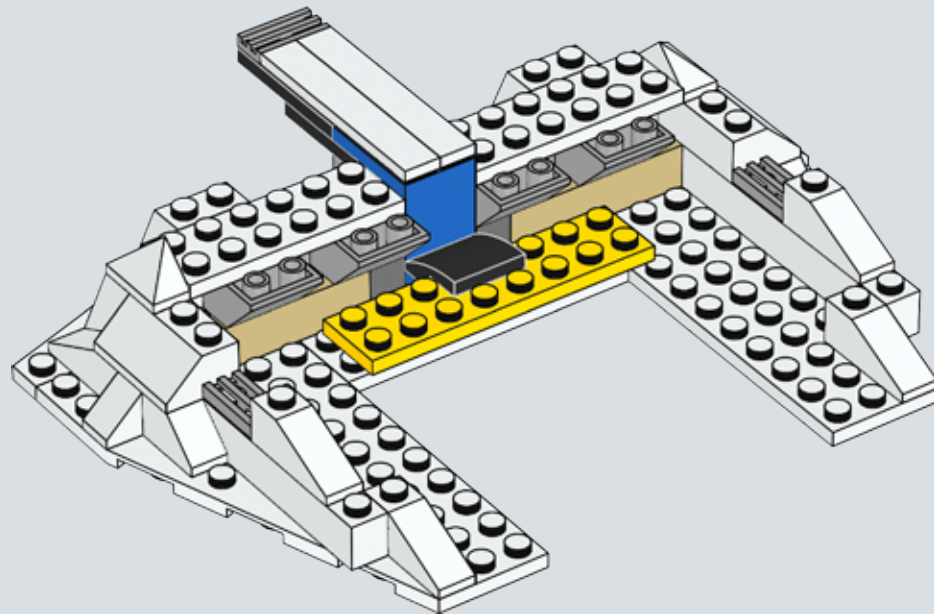

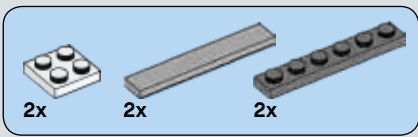

30

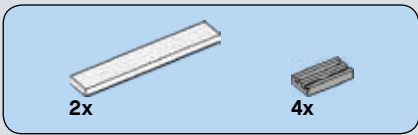
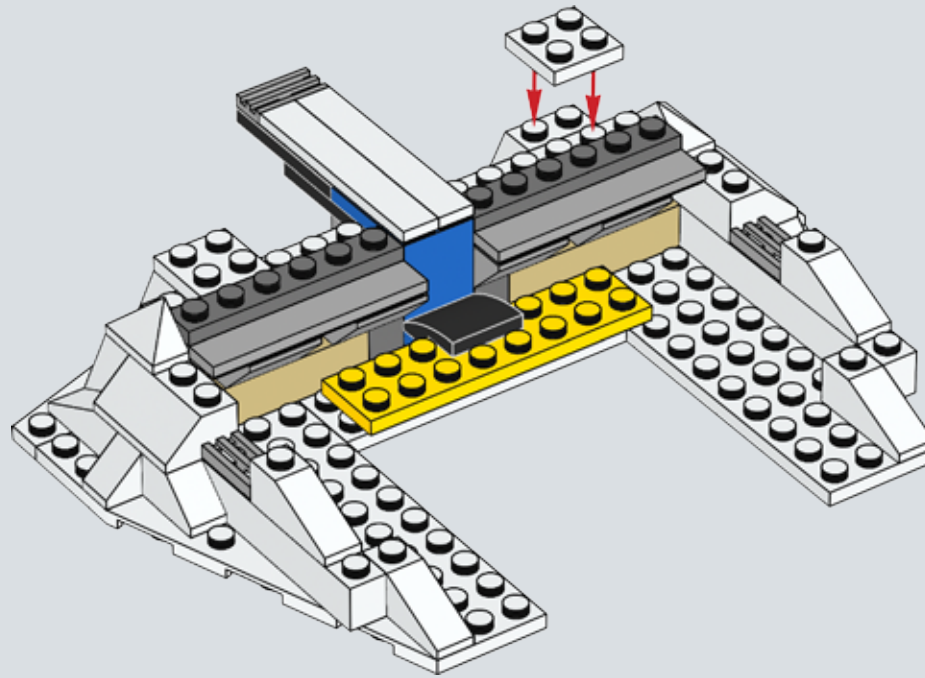

31

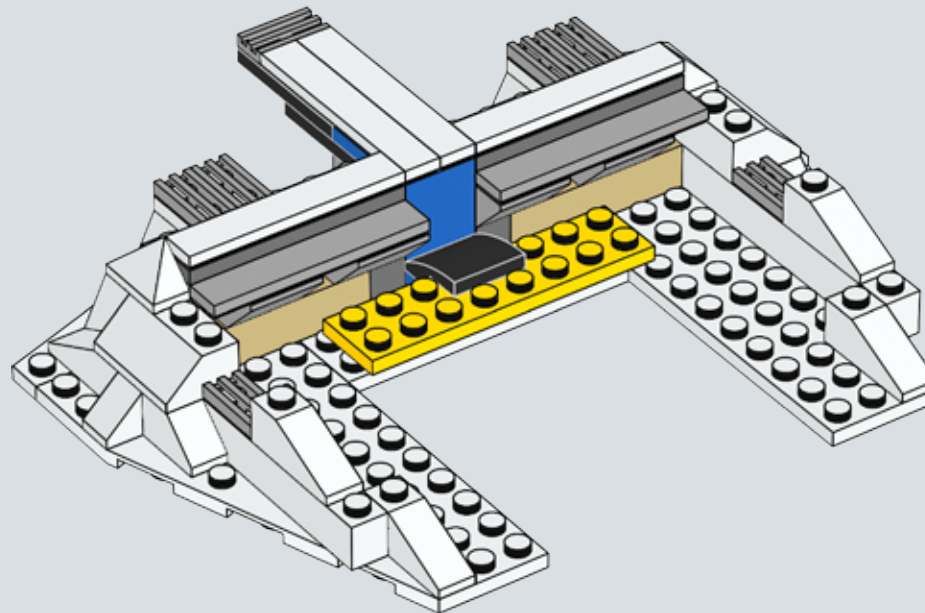

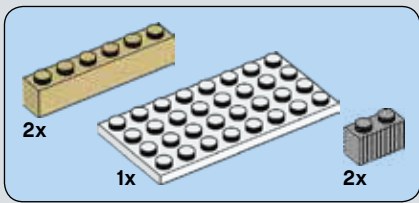

32

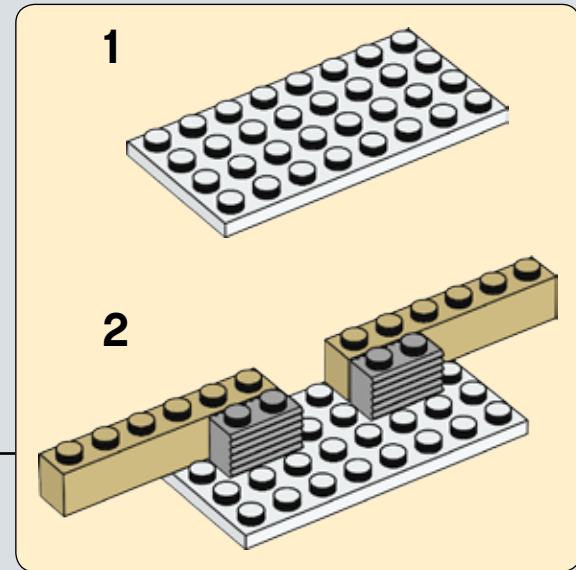
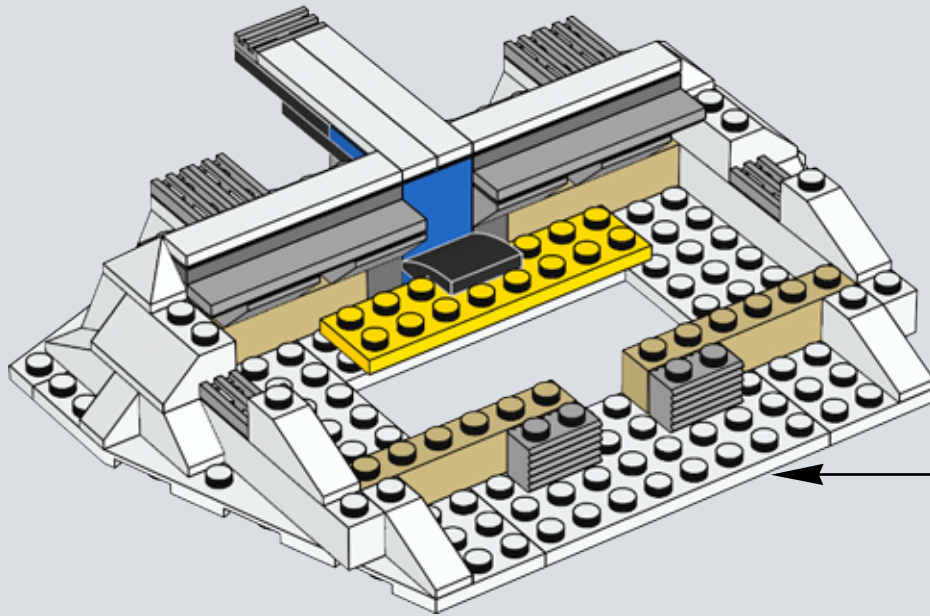



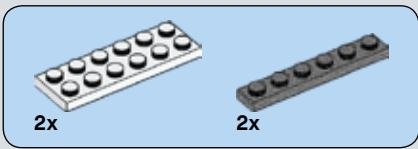

33

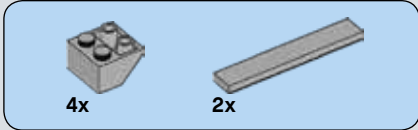
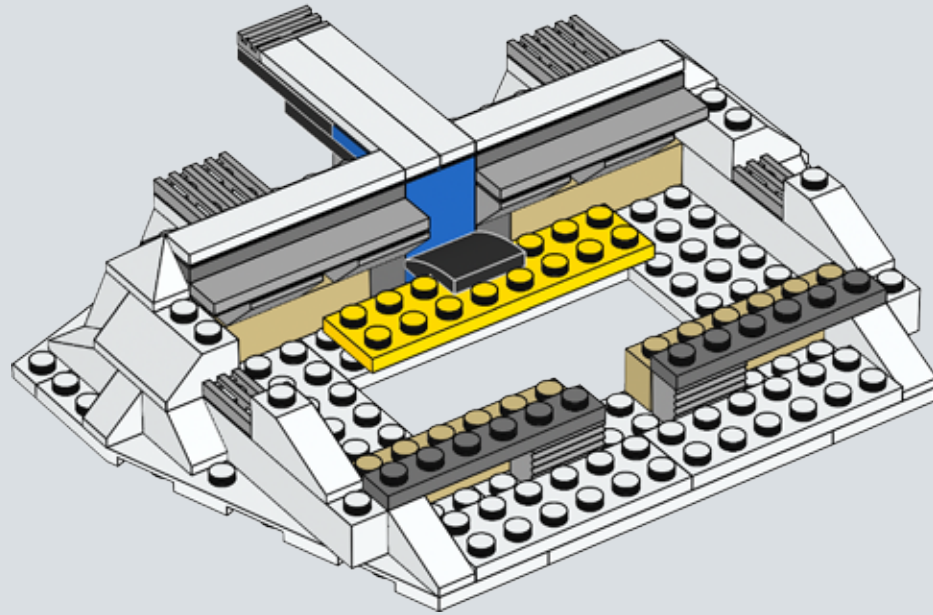

34

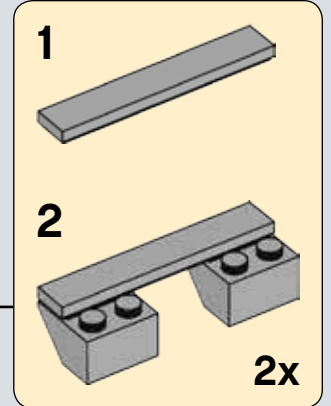
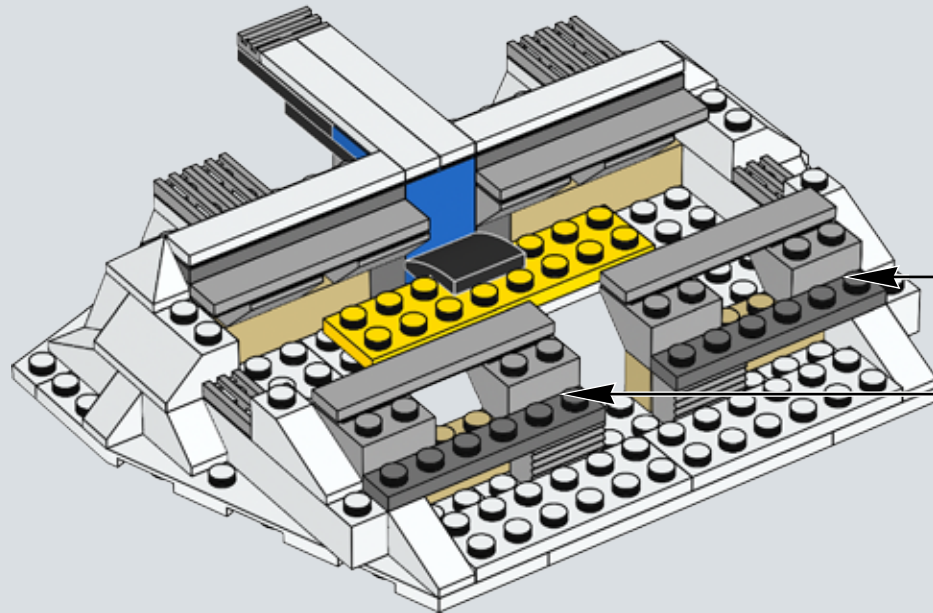

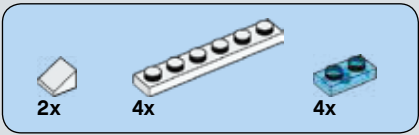

# 35

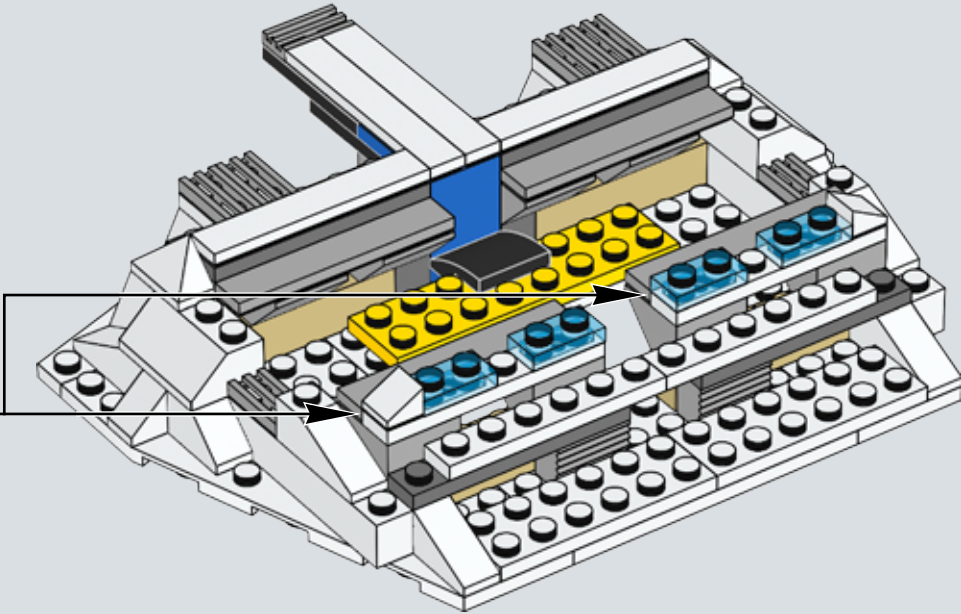
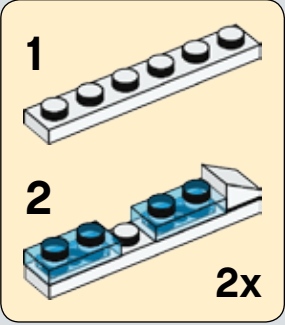

# 36

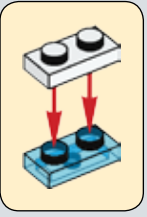
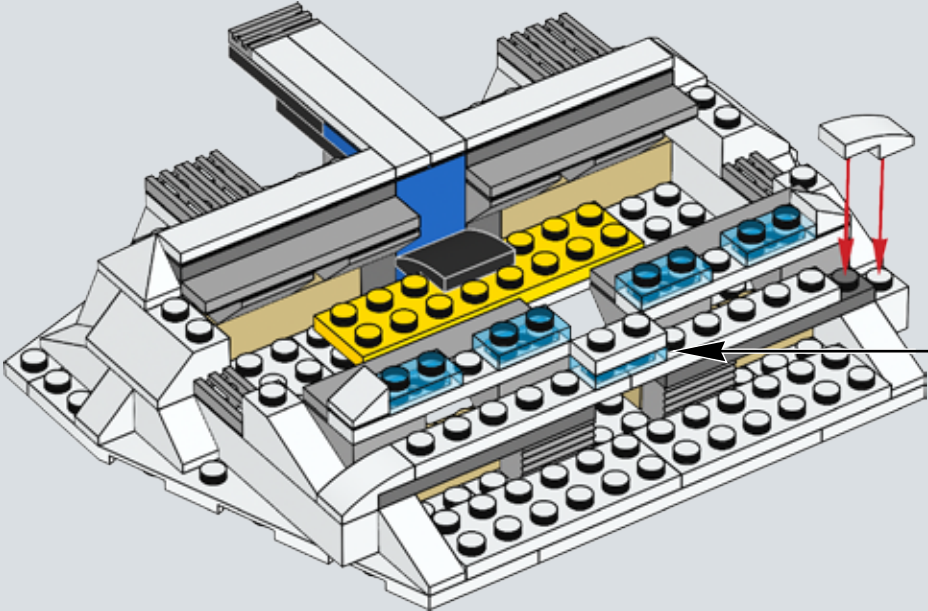

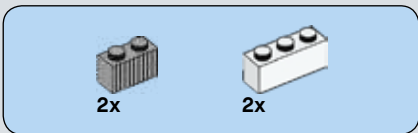

37

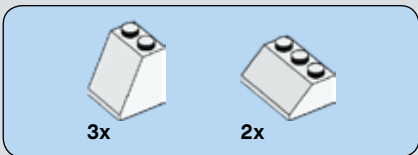
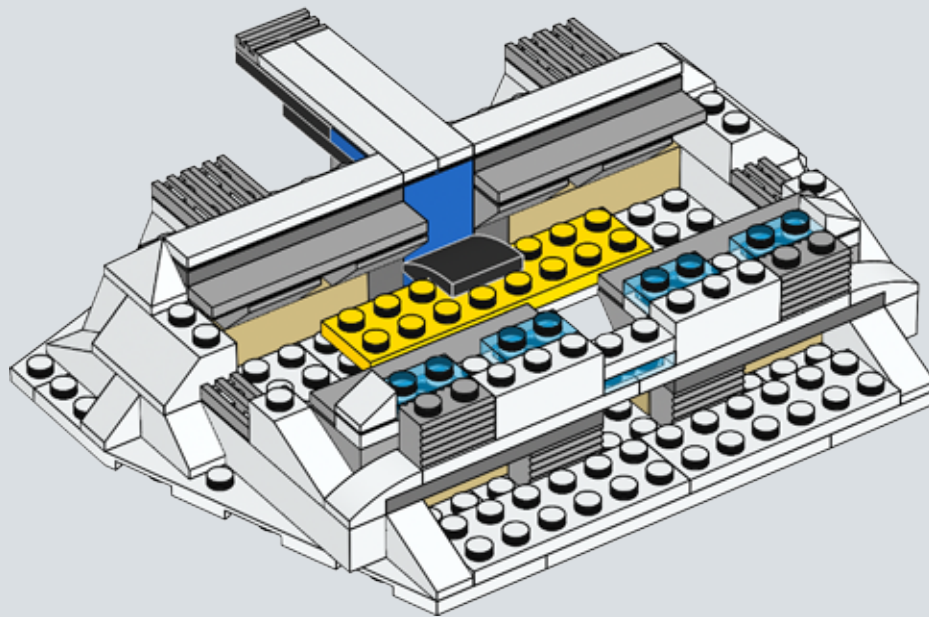

38

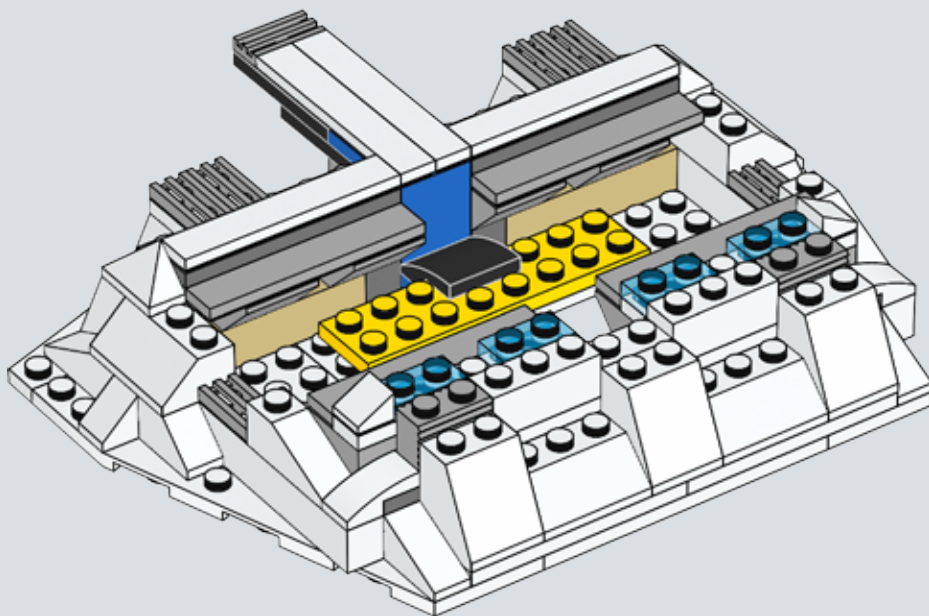



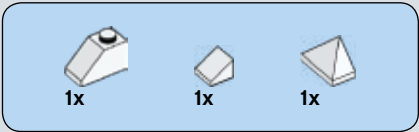

# 39

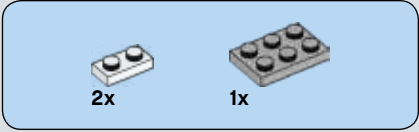
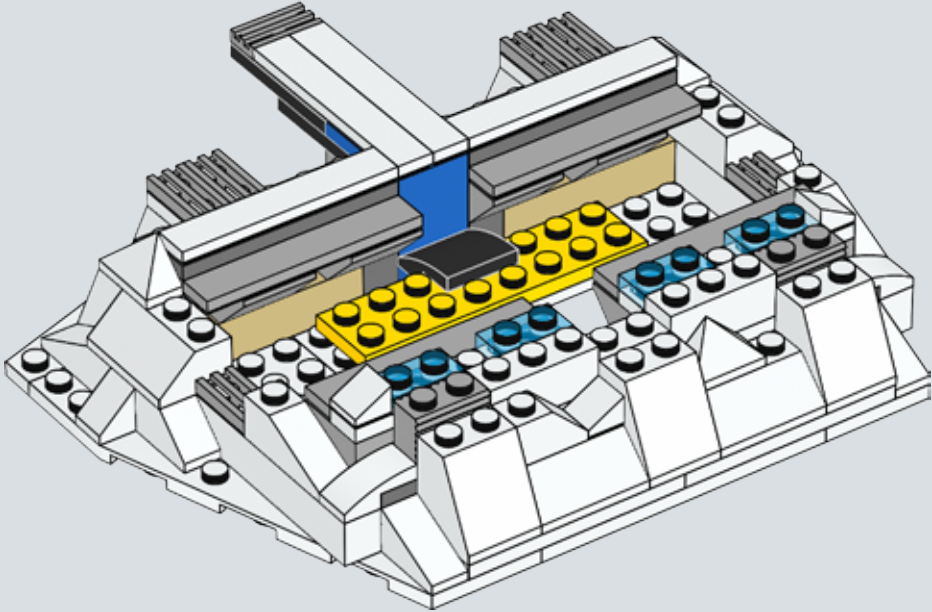

# 40

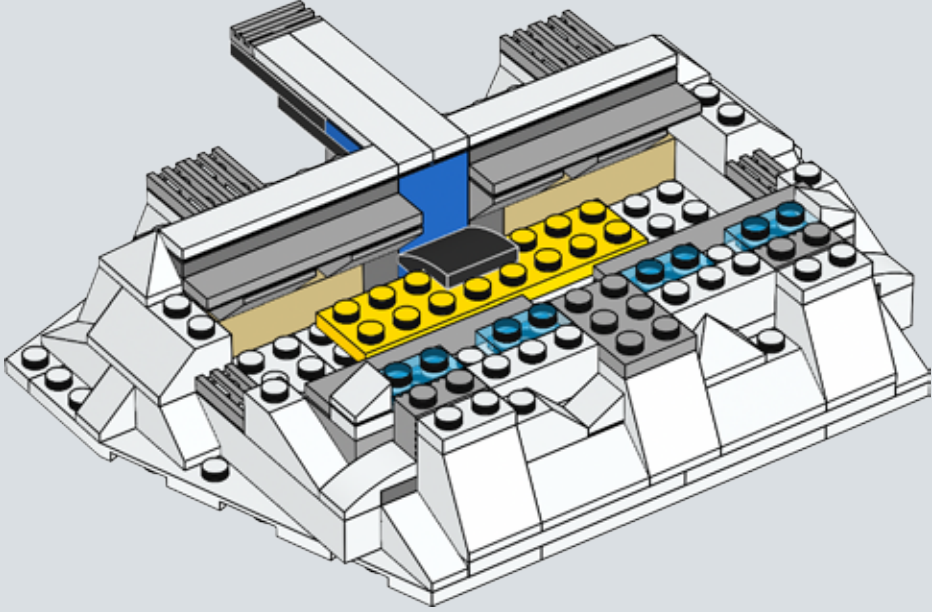



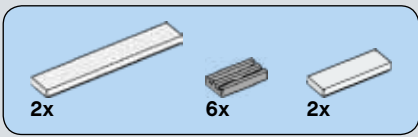

41

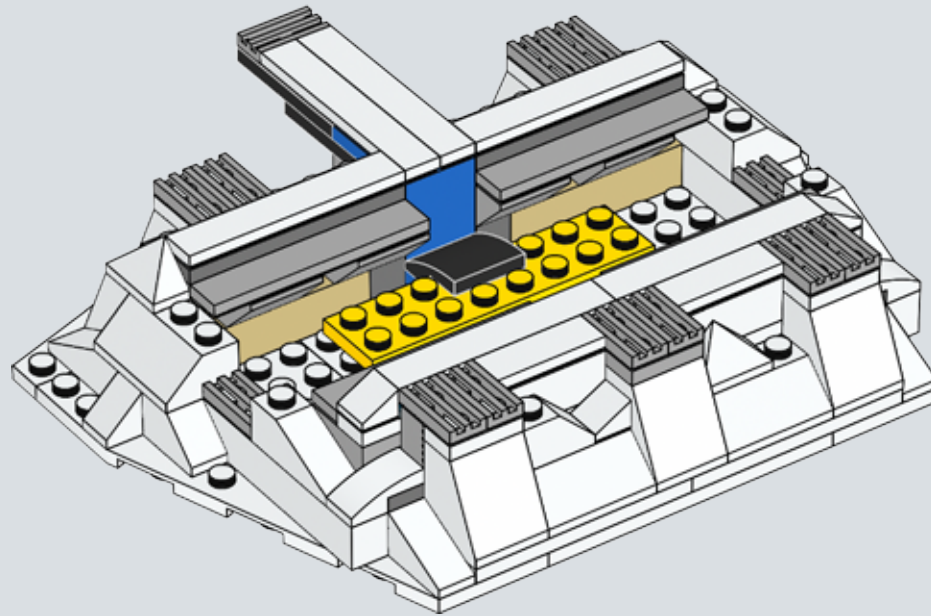

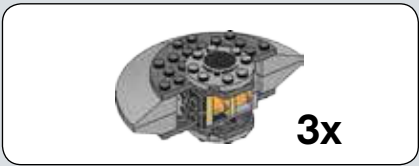

# 42

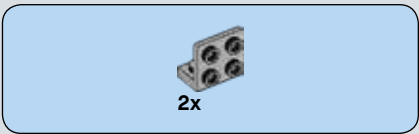
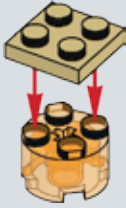

# 43

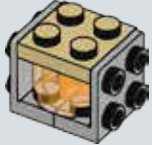

# 44

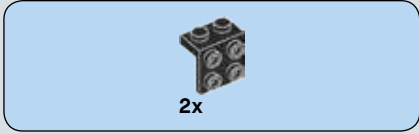
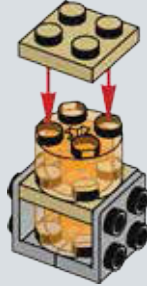

# 45



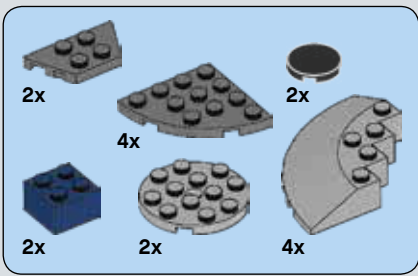

46

1

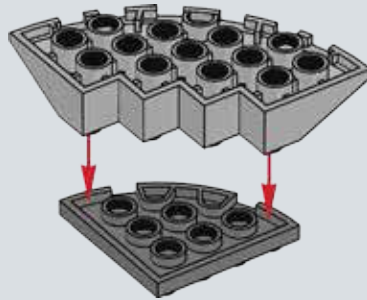

2

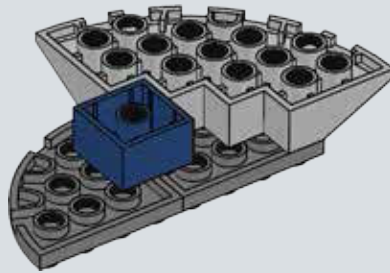

3

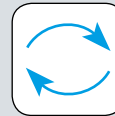
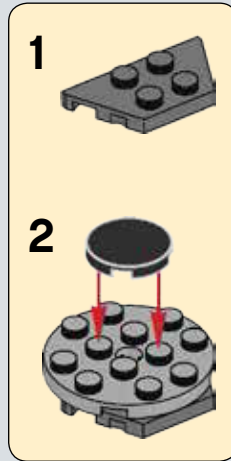
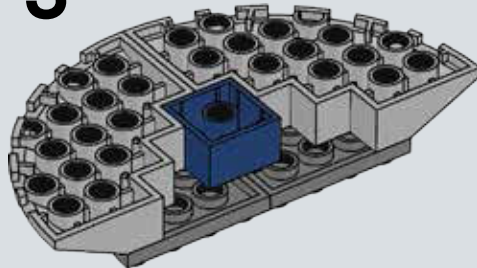

4

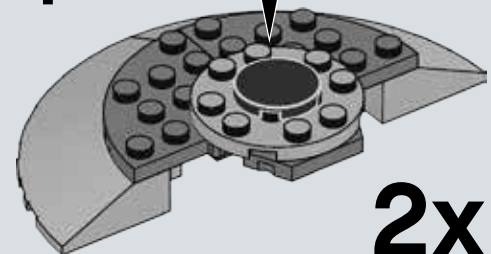

2x

47

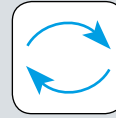
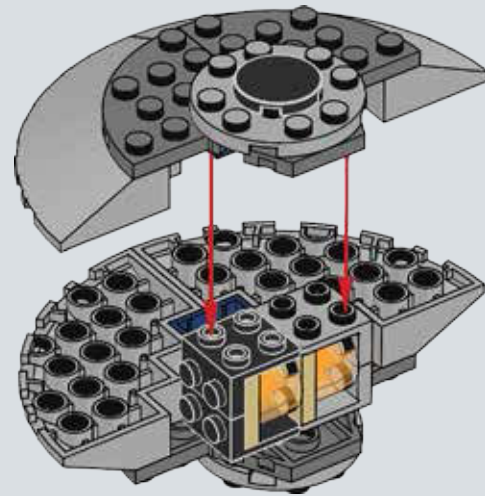

3x

48

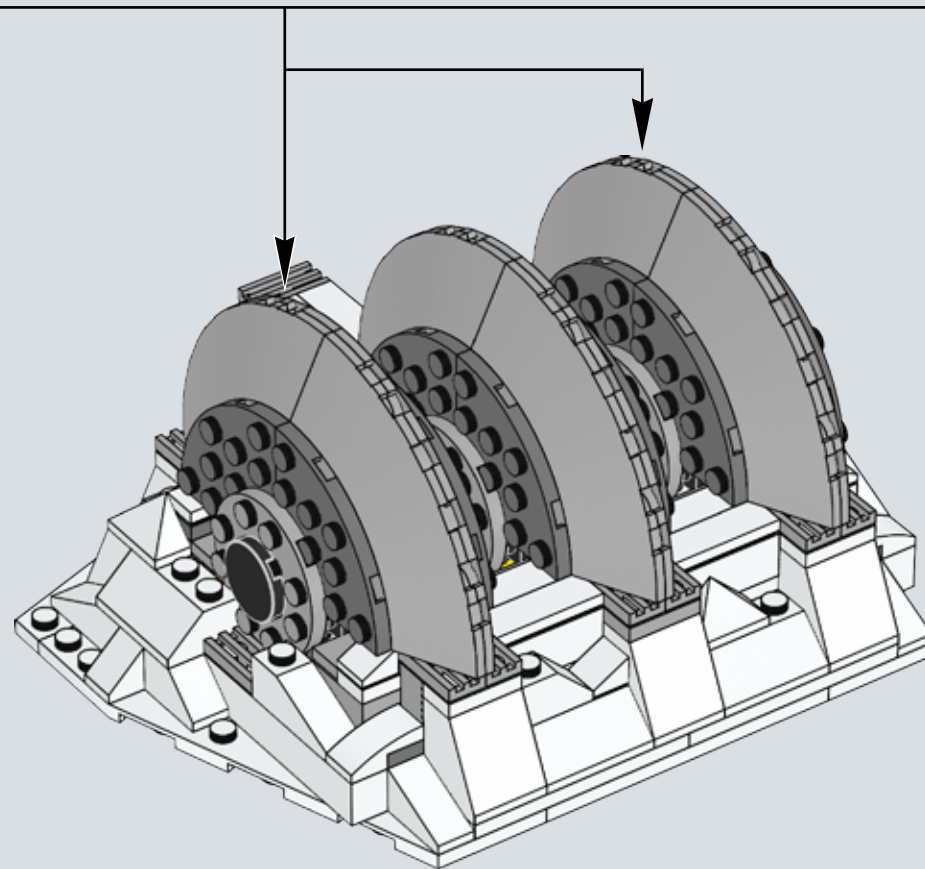



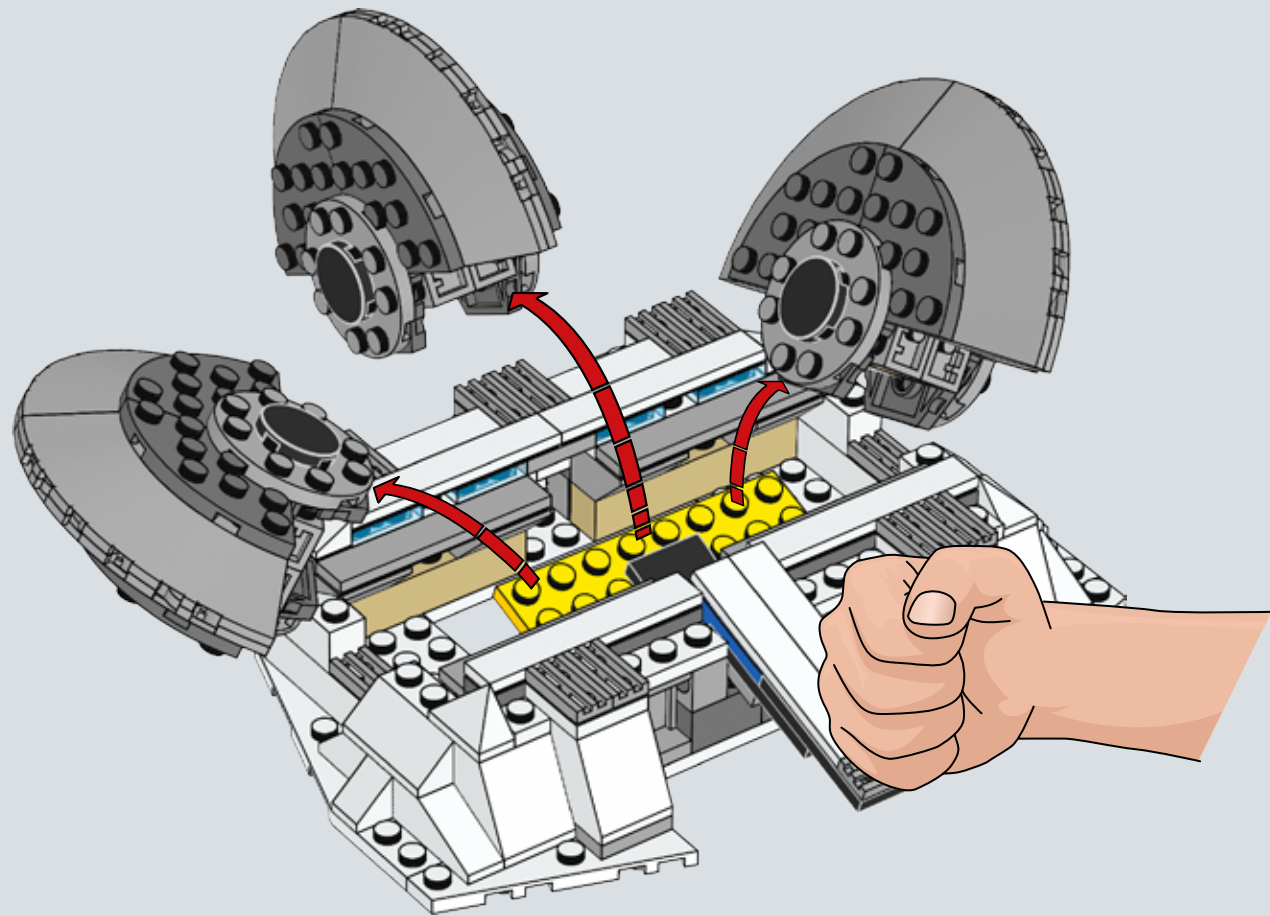

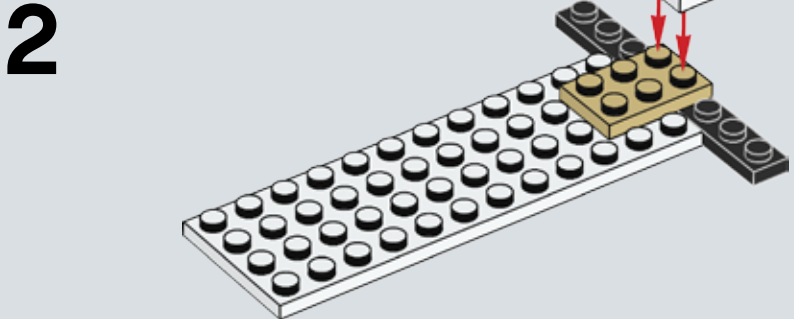
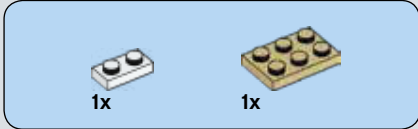
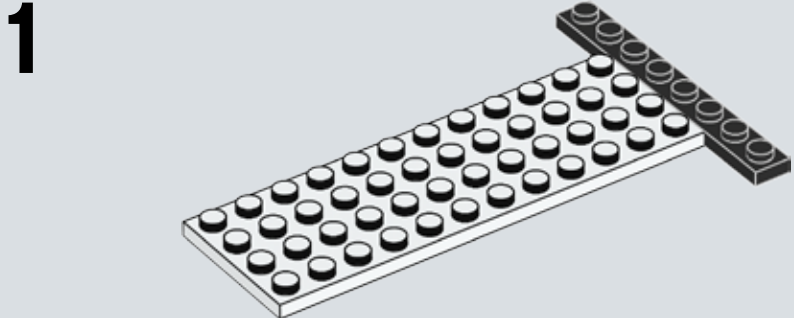
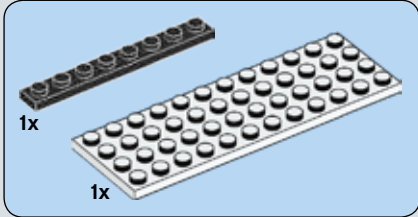
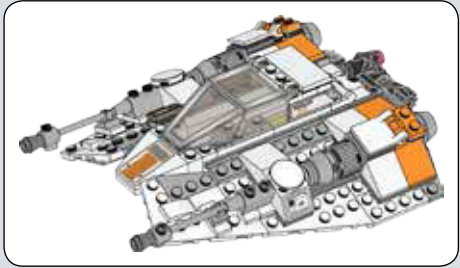
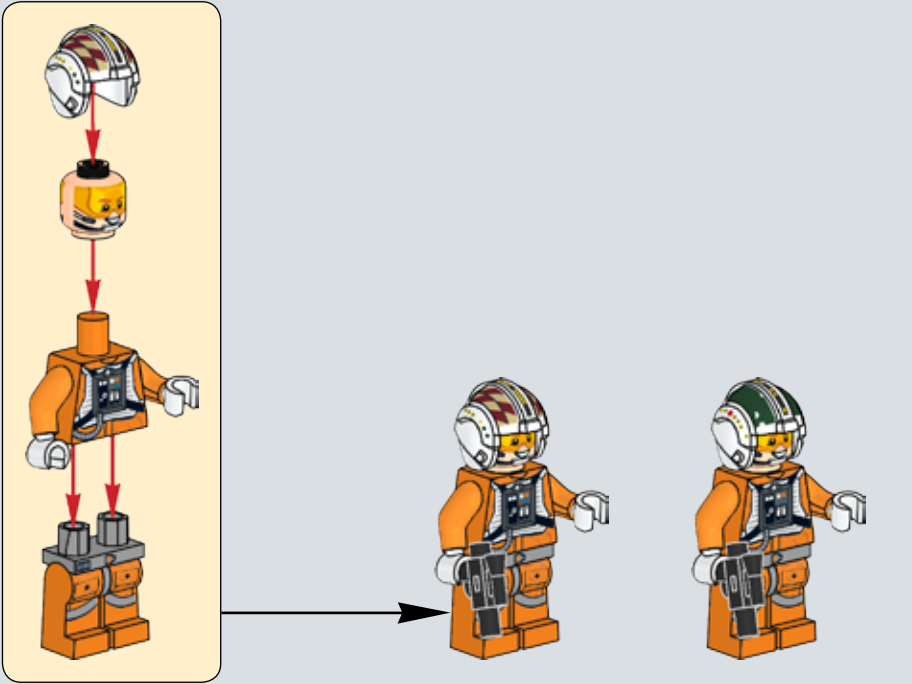
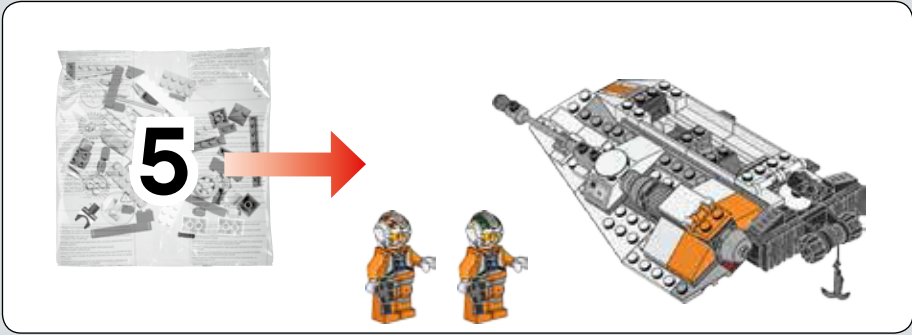



3

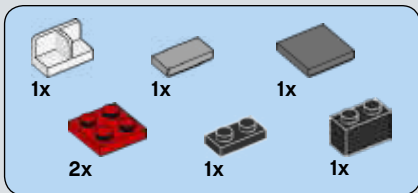
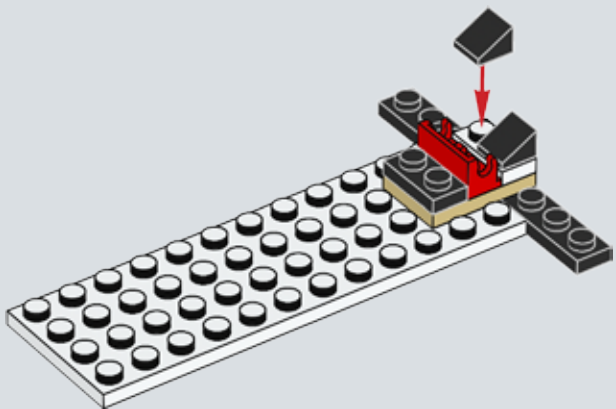

4

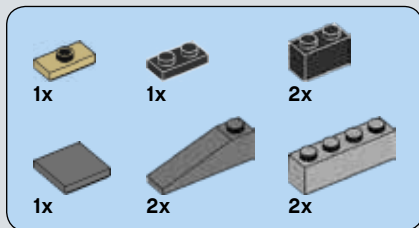
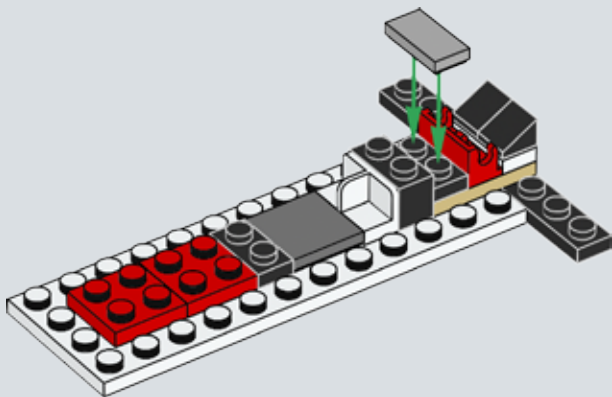

5

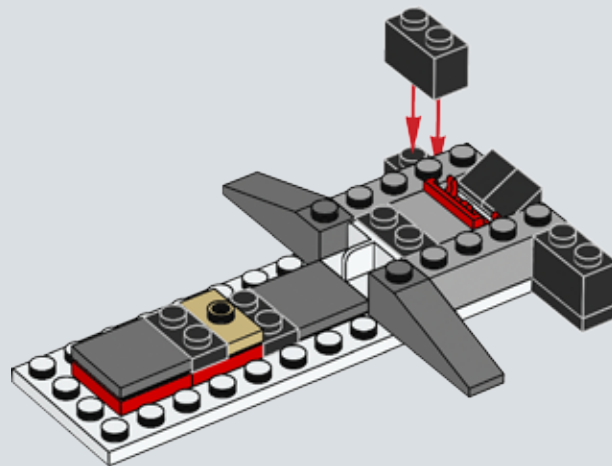



4x



2x

# 6

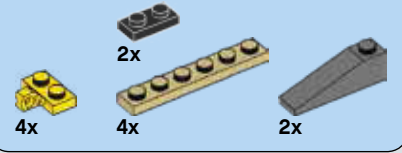
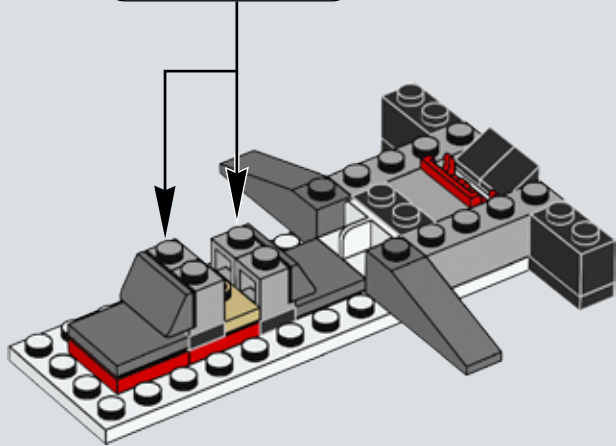
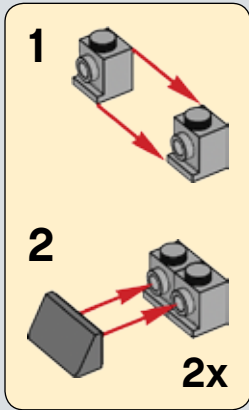

# 7

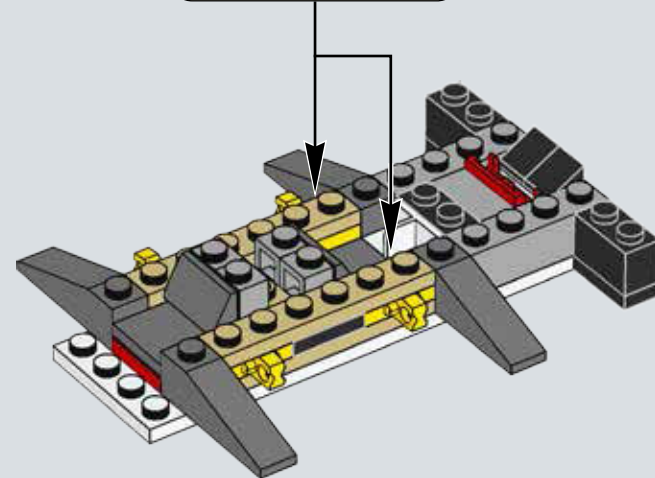
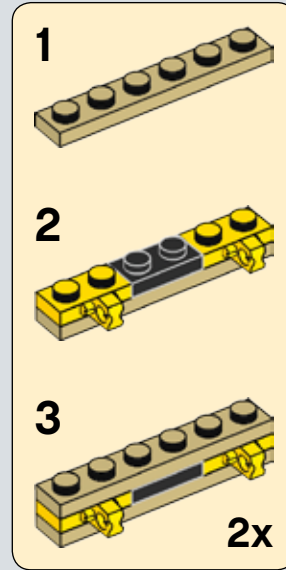



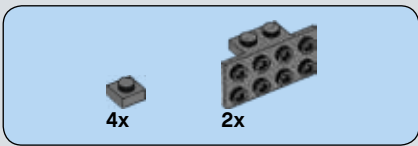

8

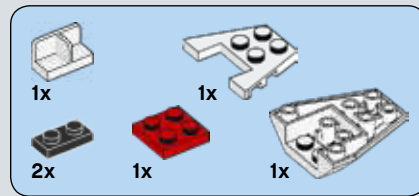
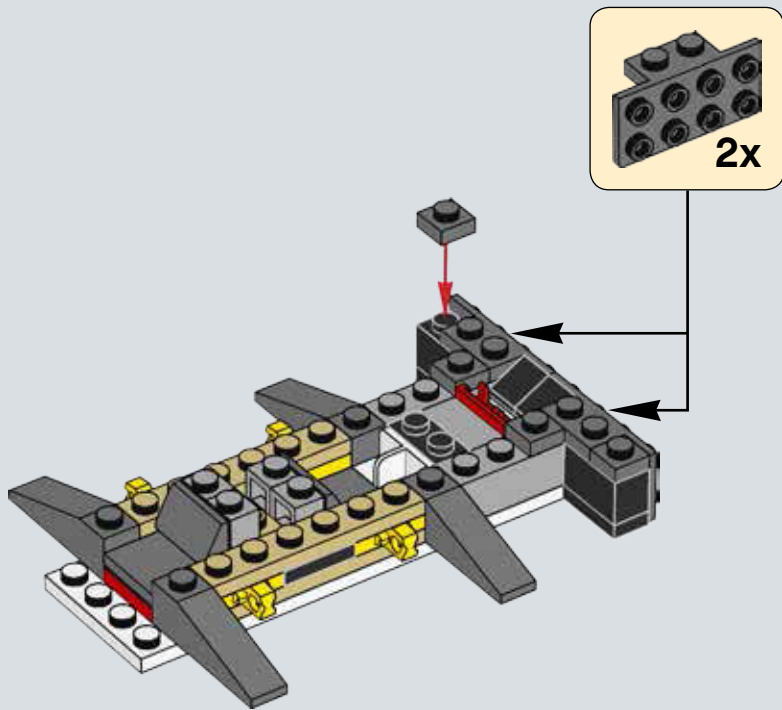

9

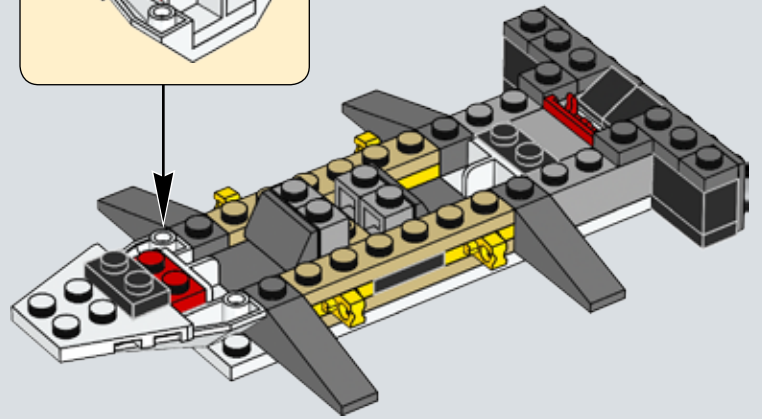
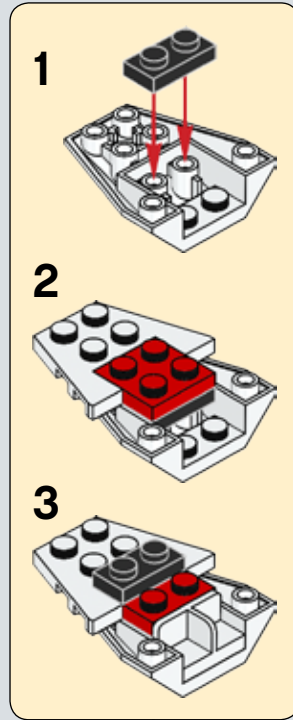

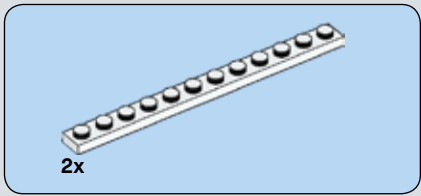

10

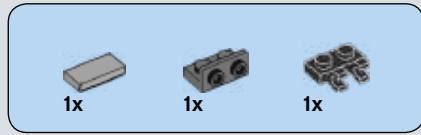
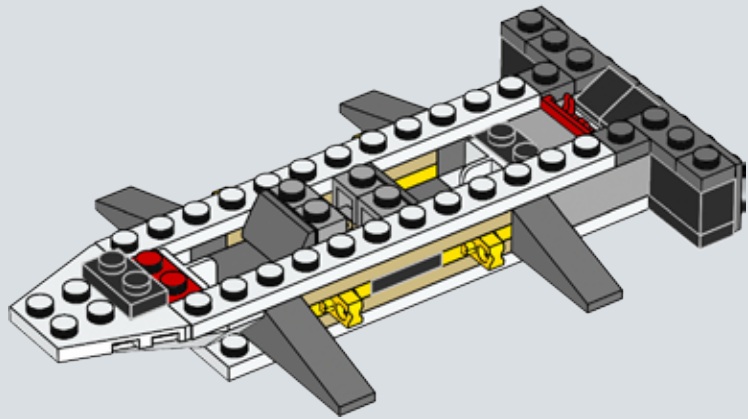

11

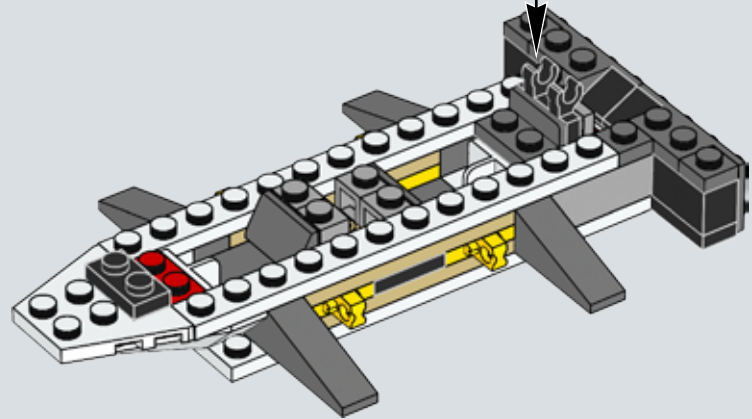
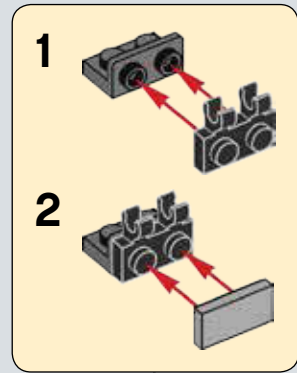

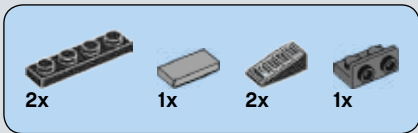

# 12

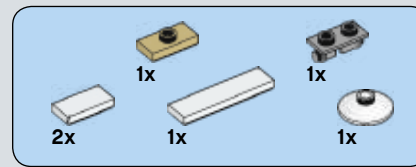
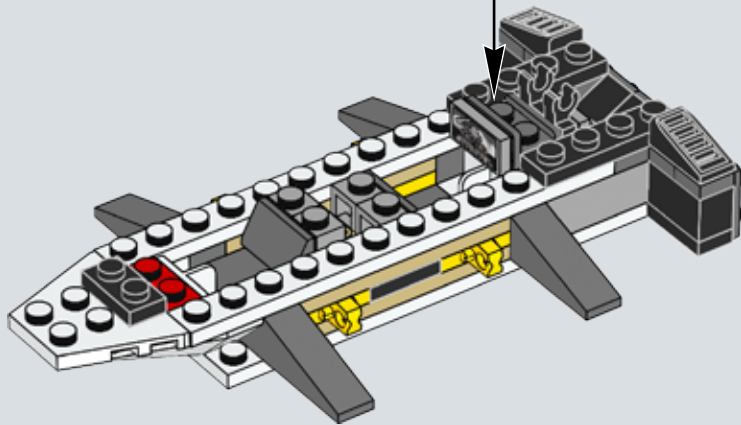
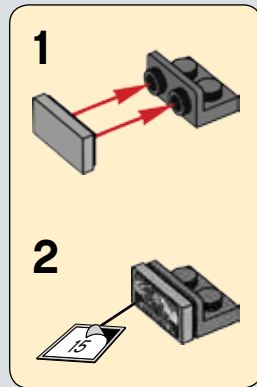

# 13

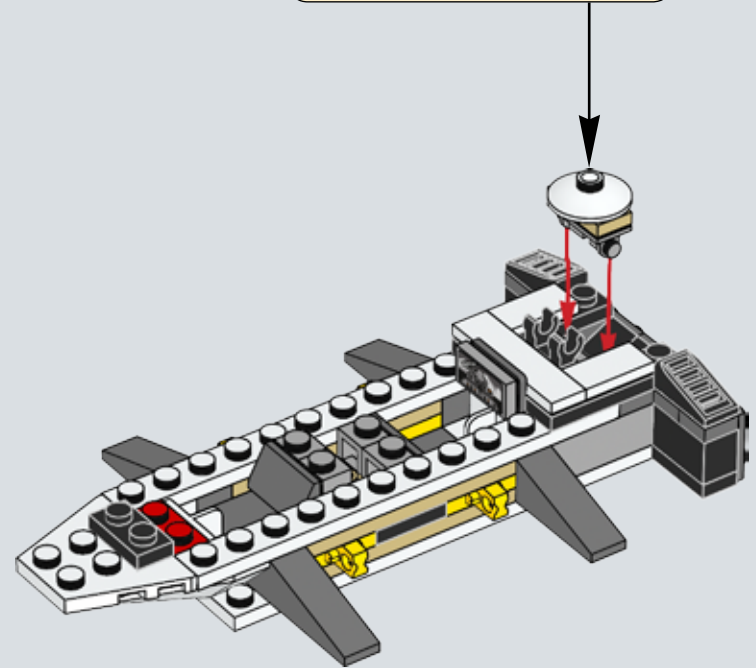
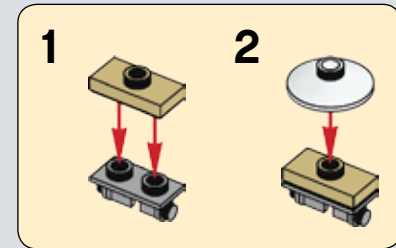



# 14

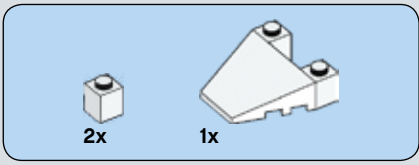
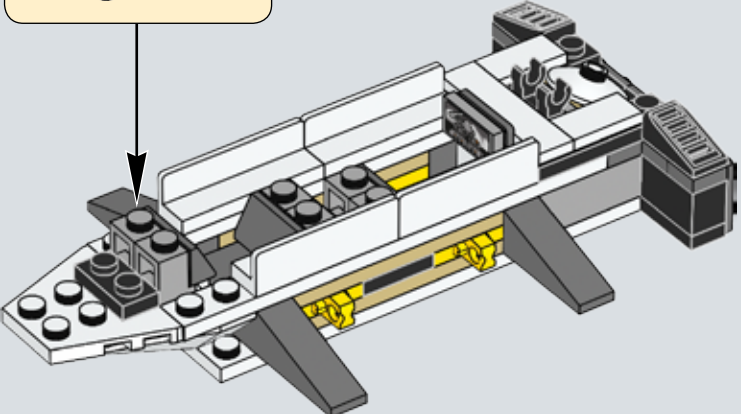
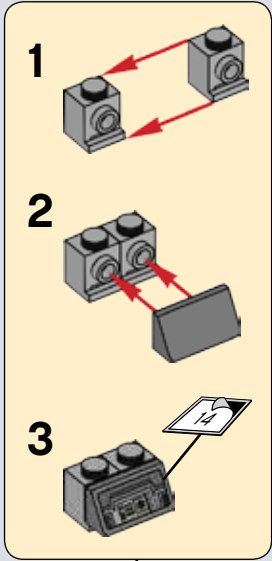

# 15

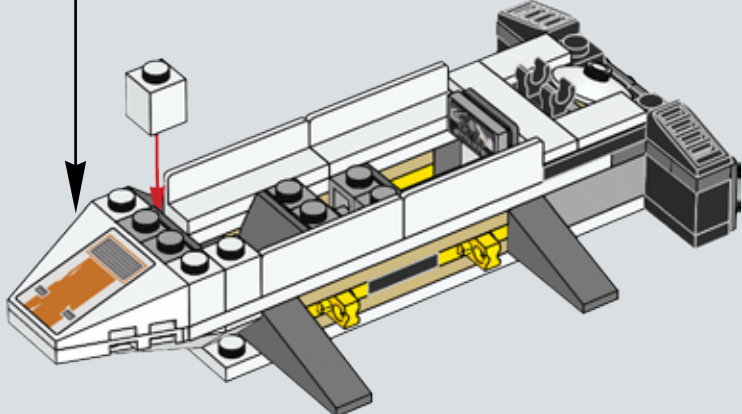
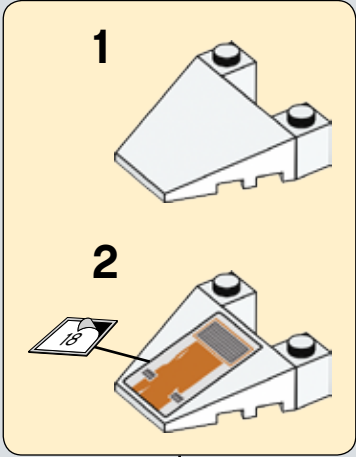



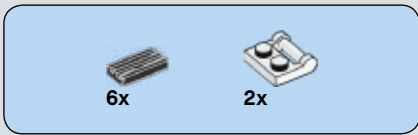

# 16

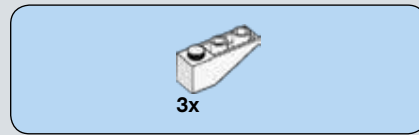
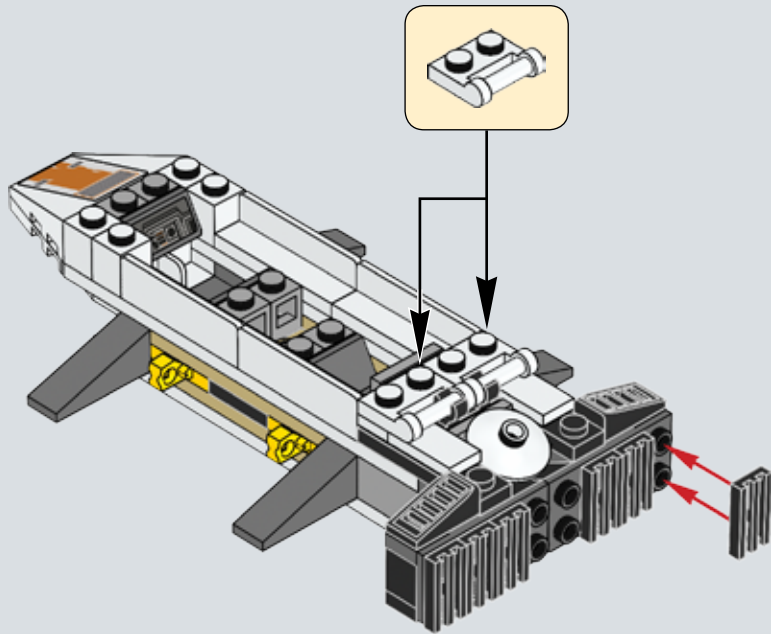

# 17

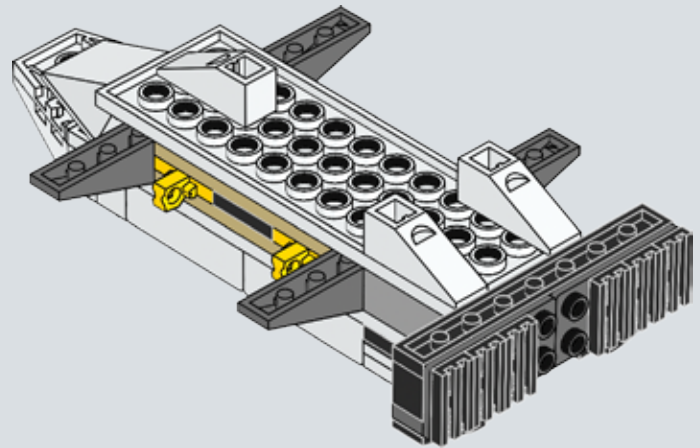
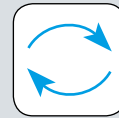

# 18

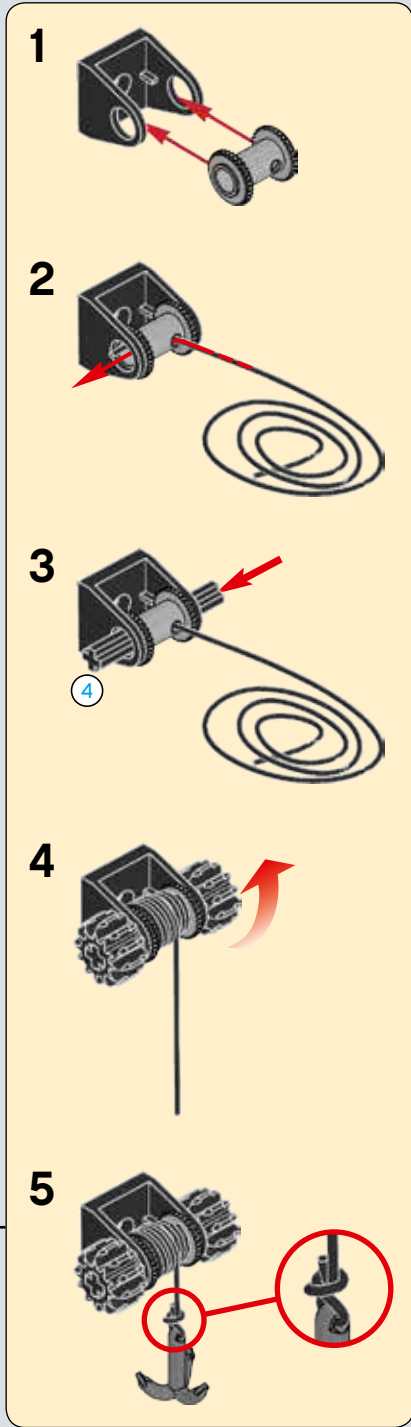
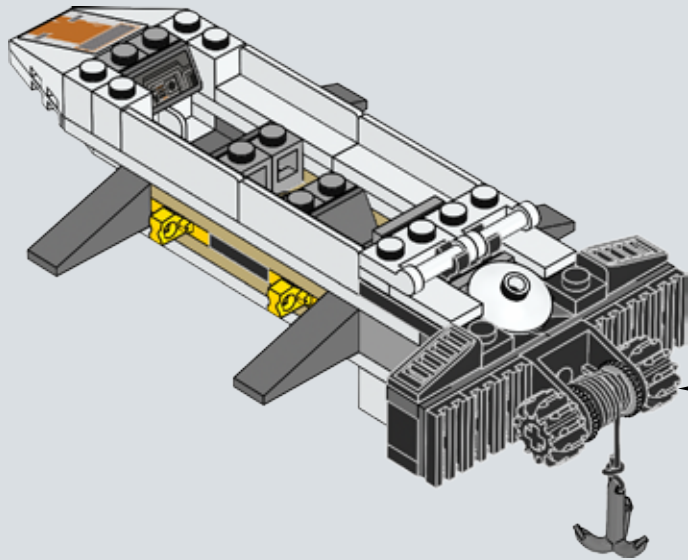
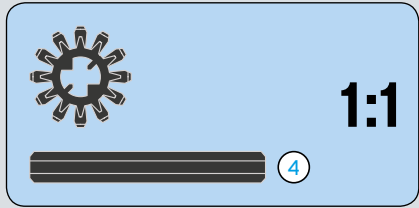
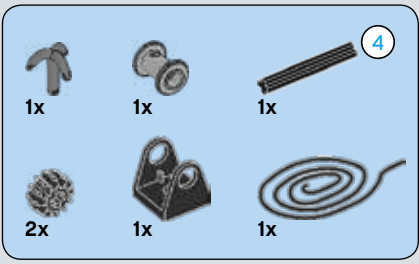

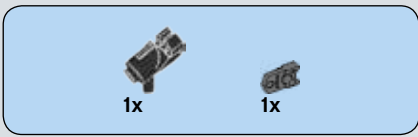

# 19

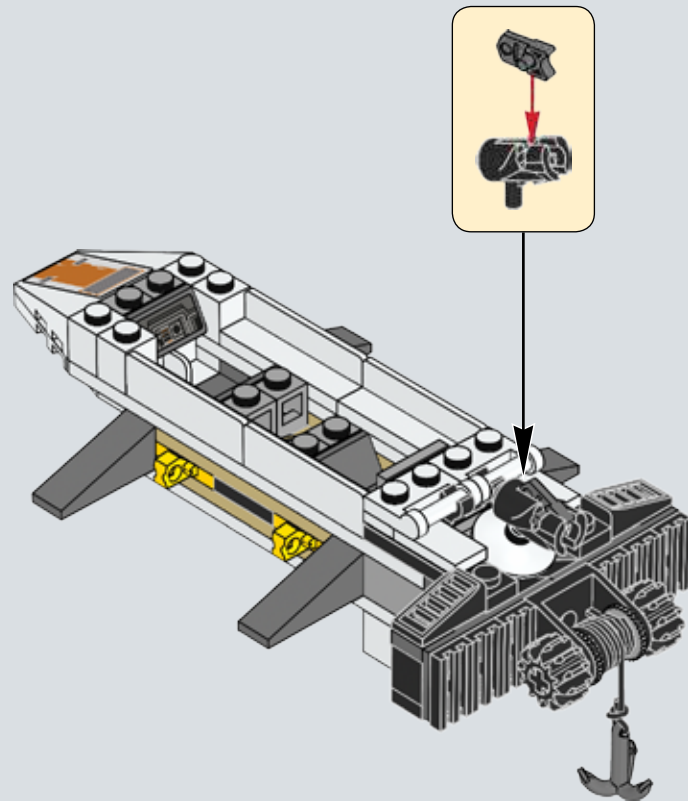

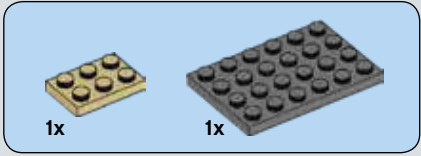
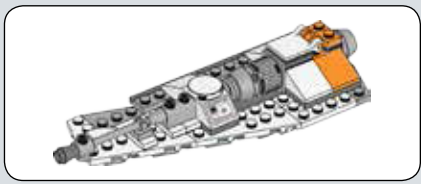

# 20

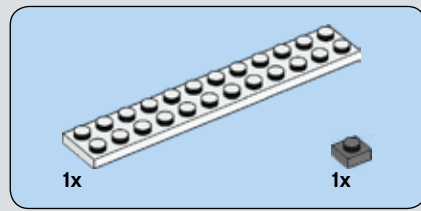
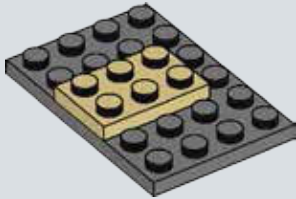

# 21

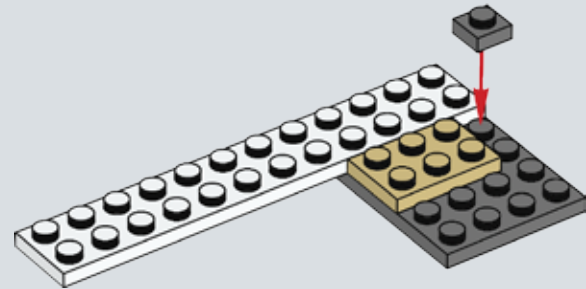



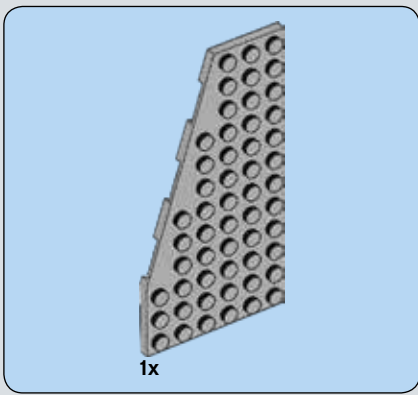

1x

# 22

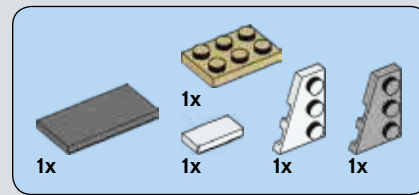
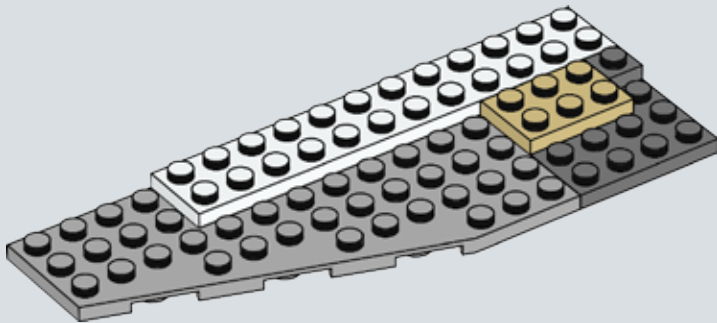

# 23

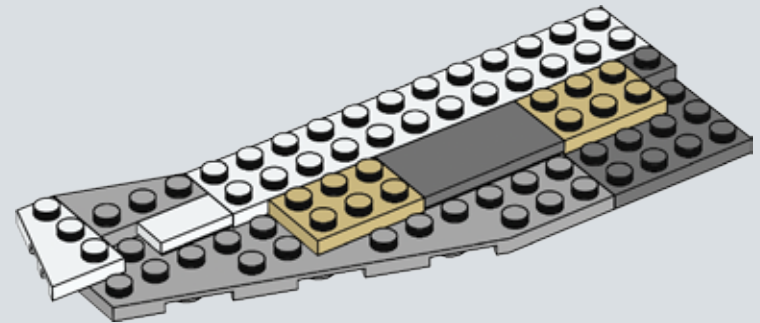

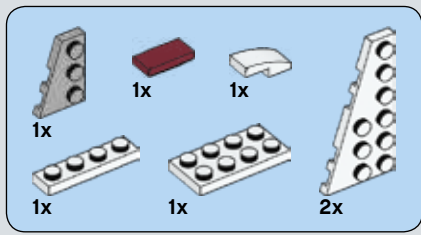

24

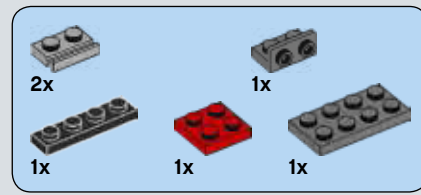
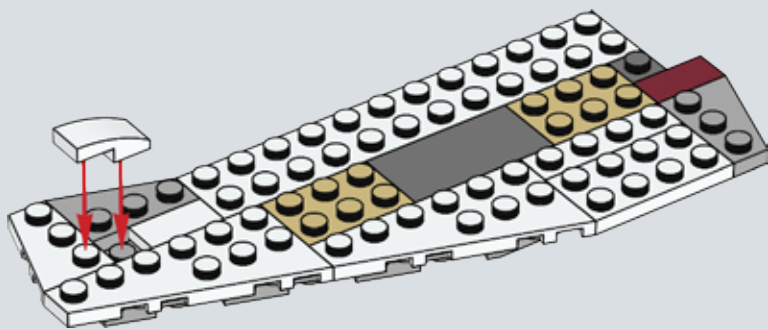

25

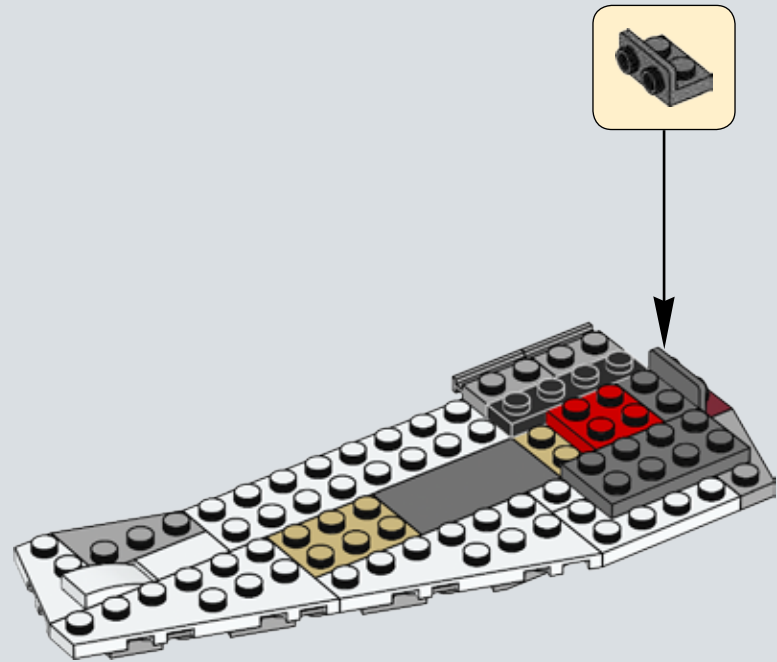

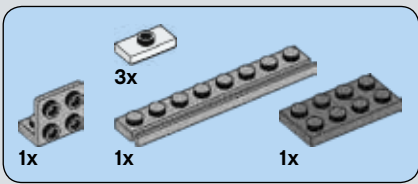

26

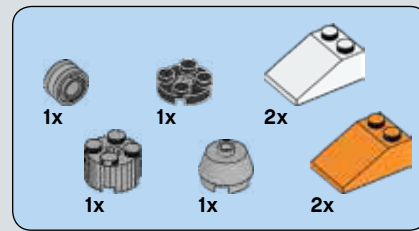
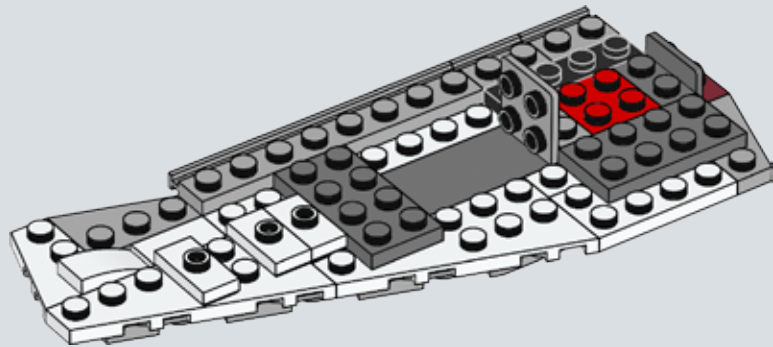

27

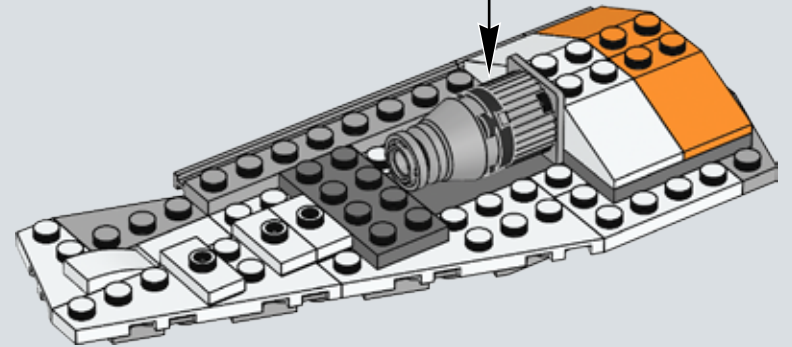
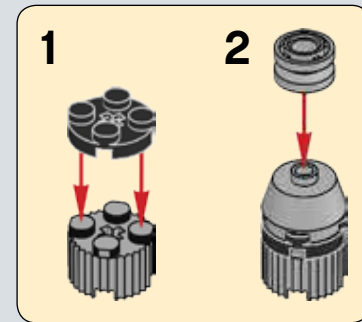

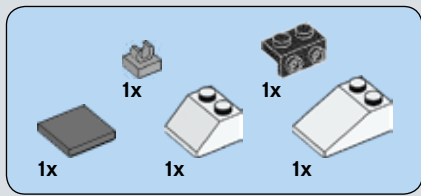

28

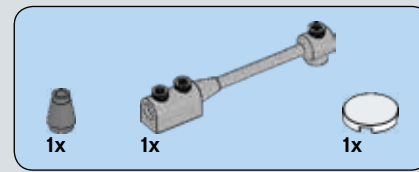
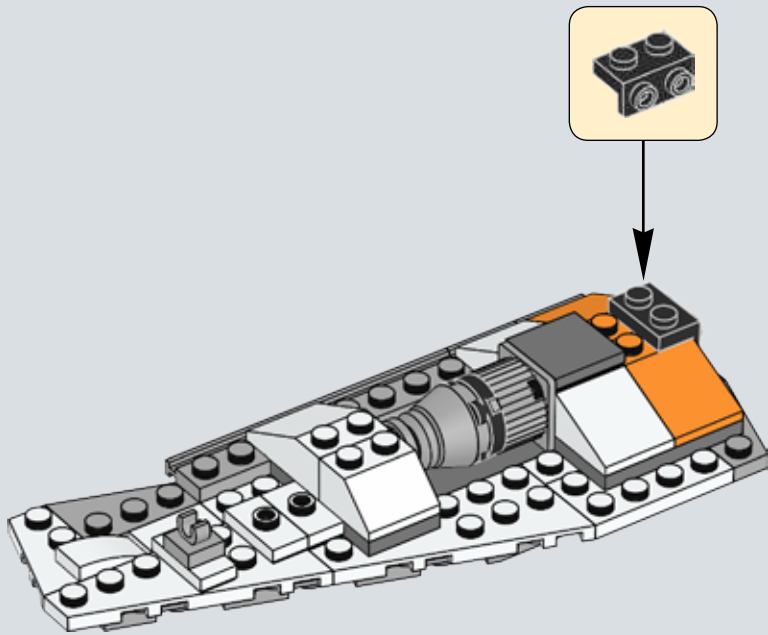

29

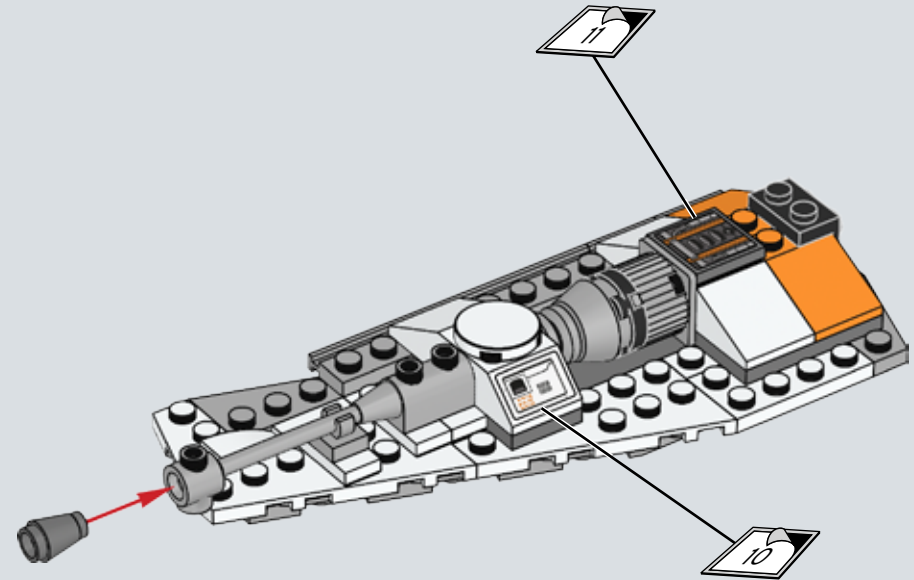



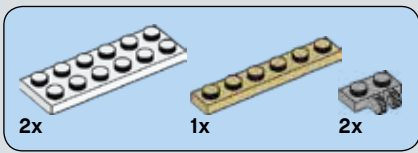

# 30

- 1
- 2
- 3

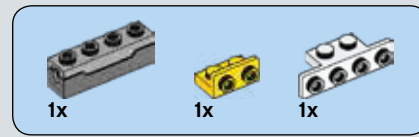
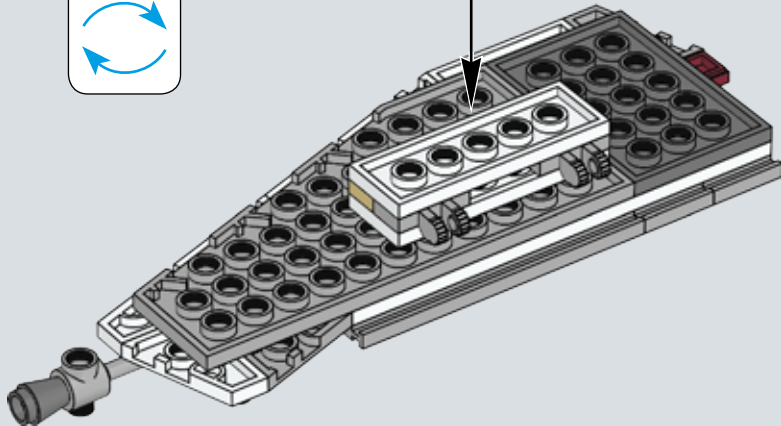
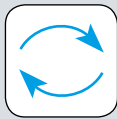

# 31

- 1
- 2
- 3
- 4

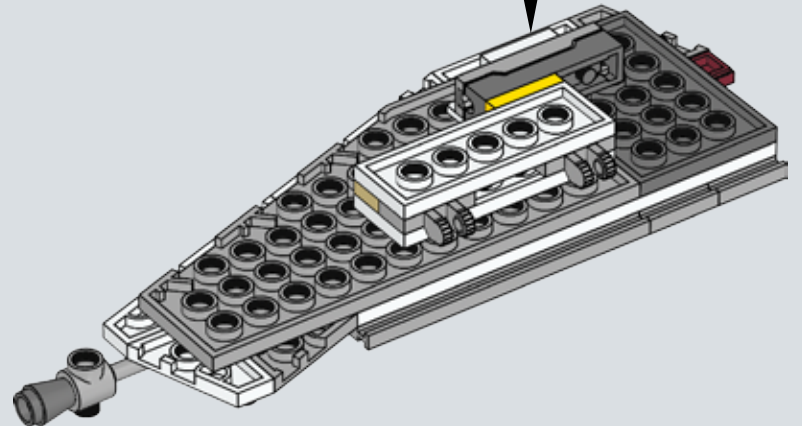

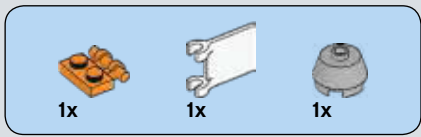

32

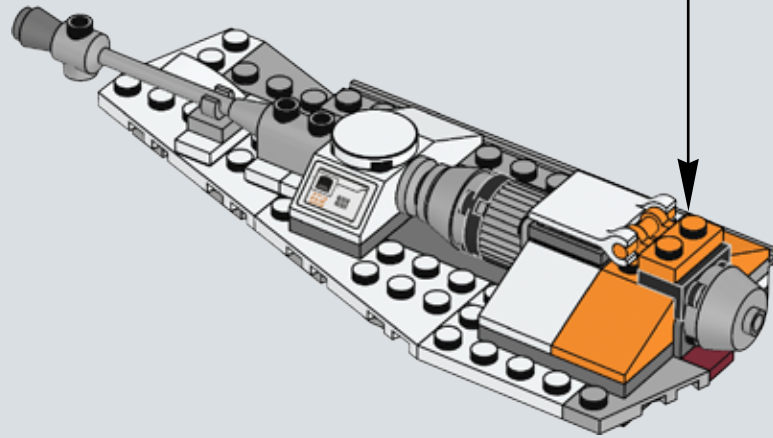
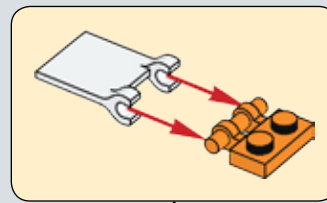

33

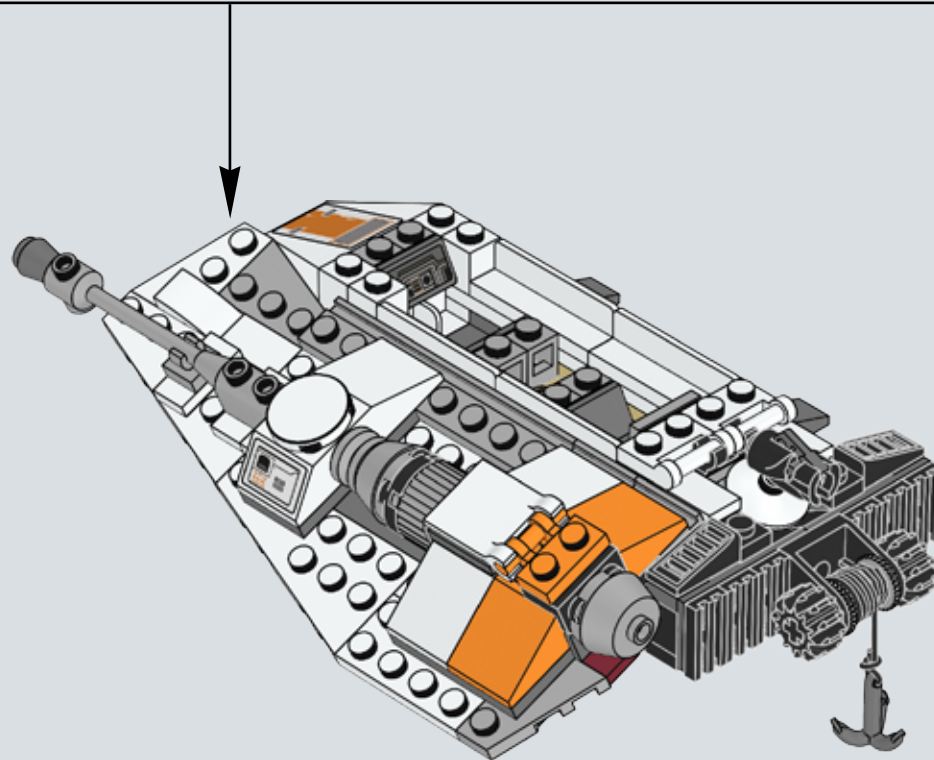

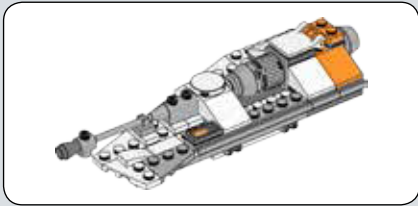
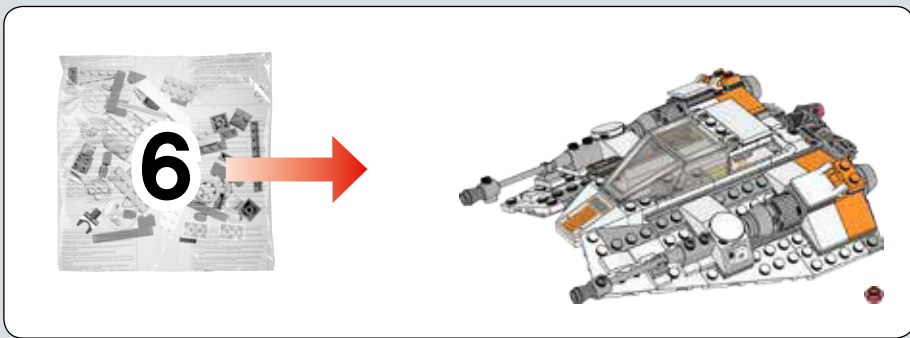

34

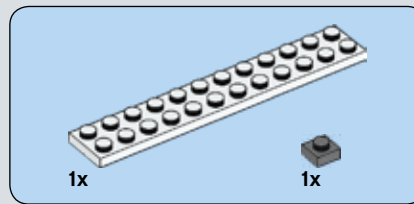
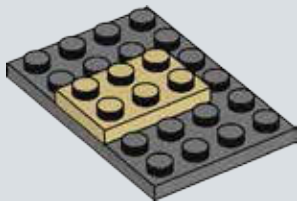

35

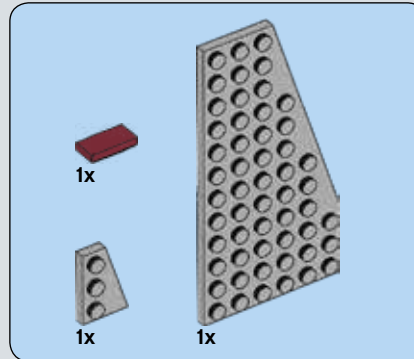
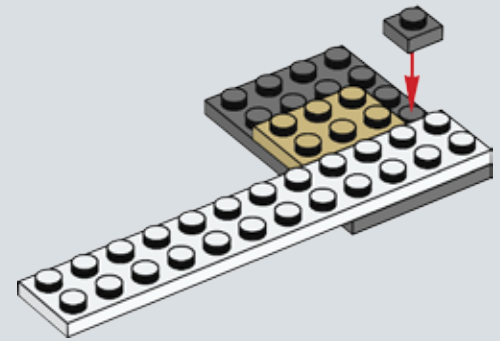

36

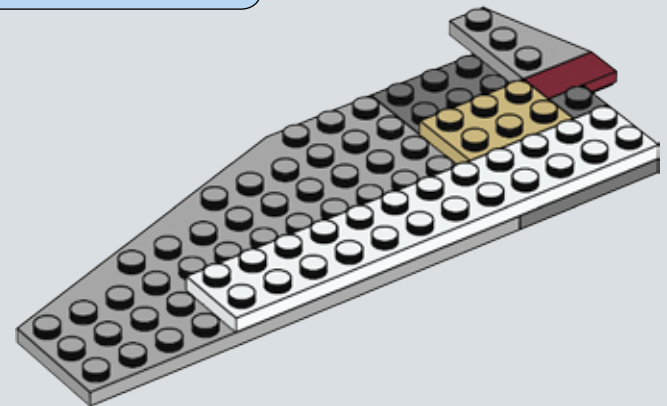

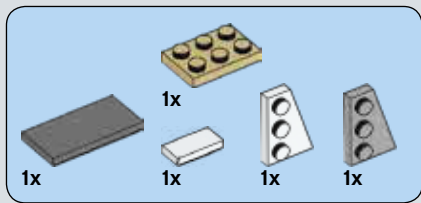

37

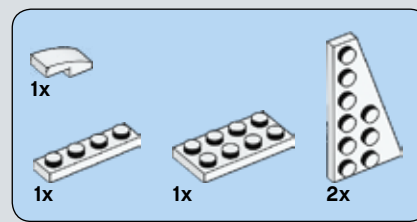
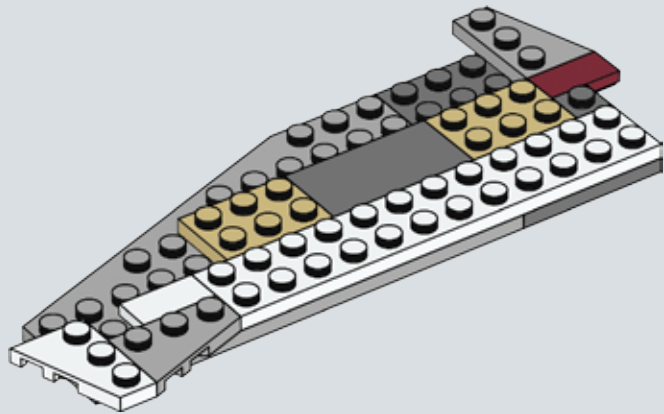

38

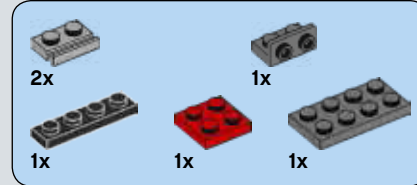
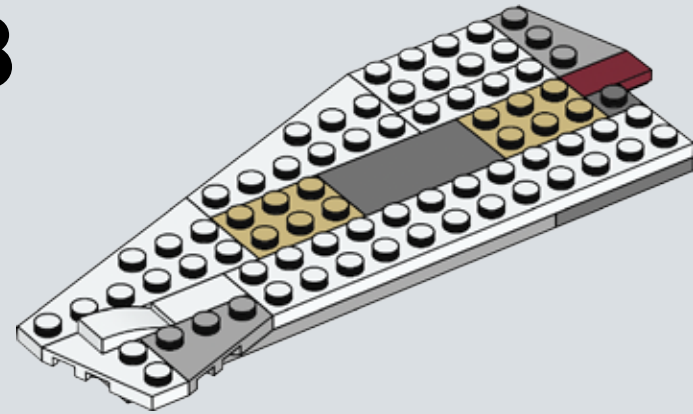

39

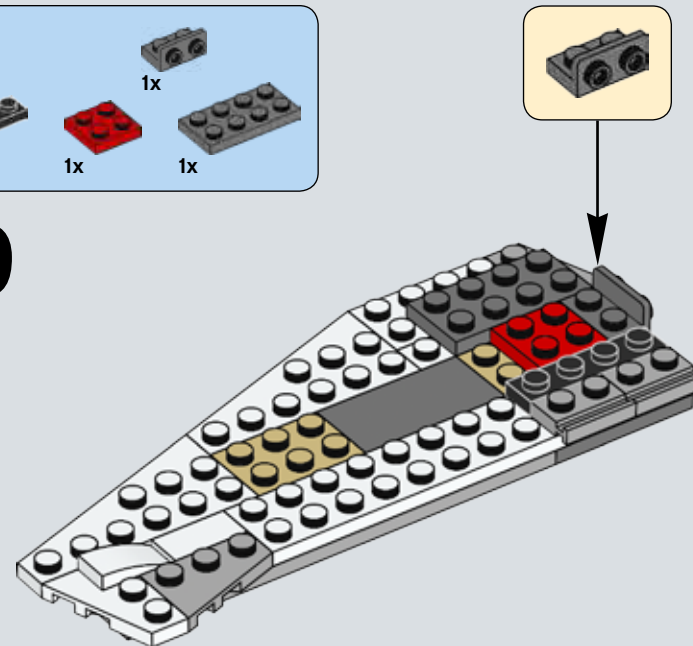



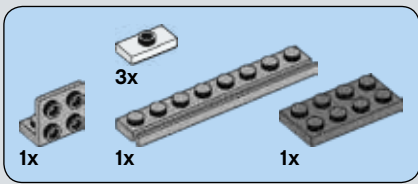

40

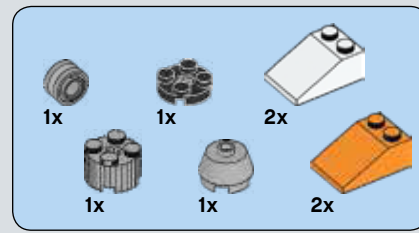
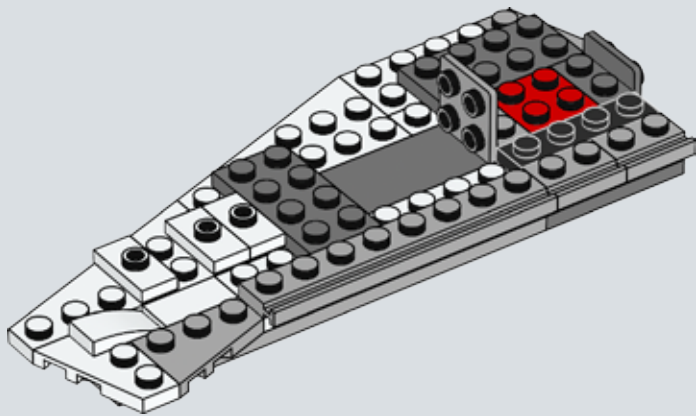

41

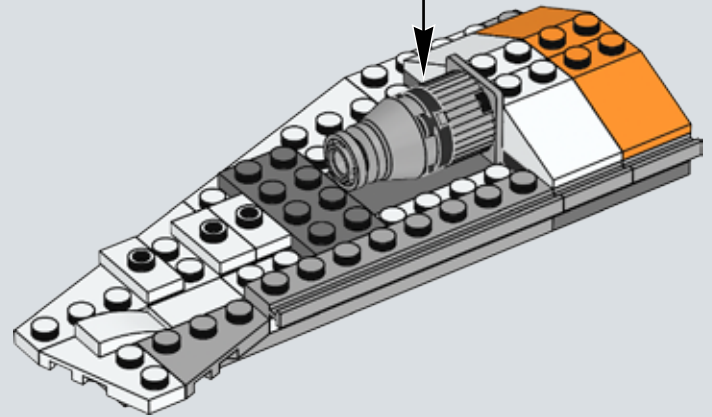
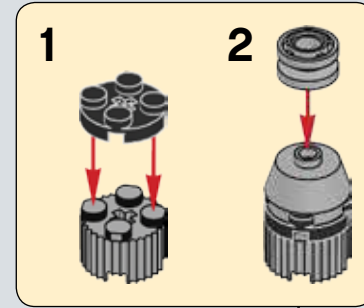

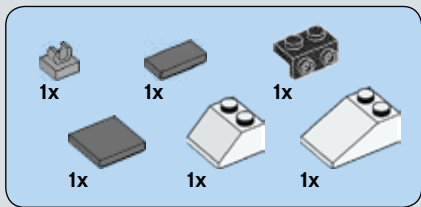

# 42

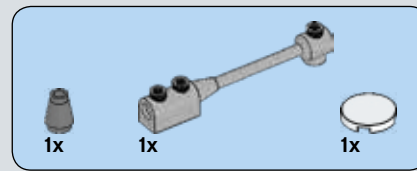
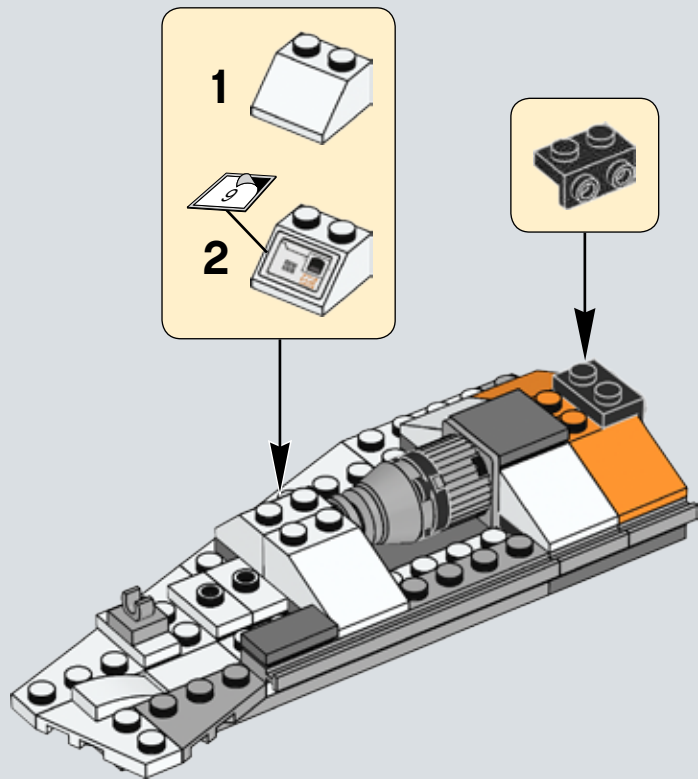

# 43

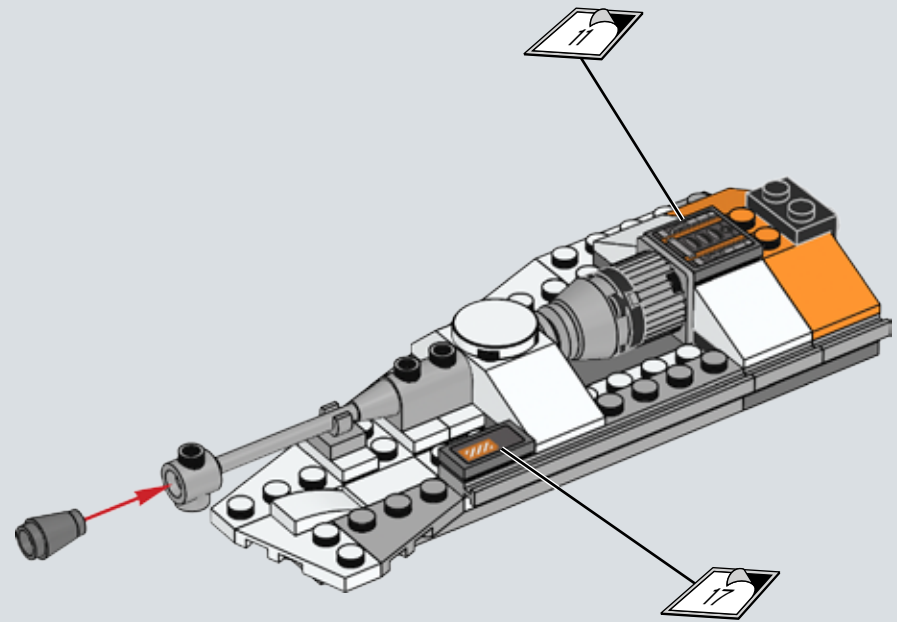

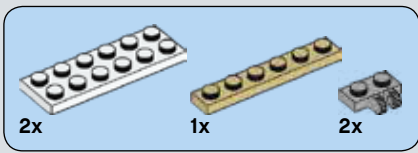

# 44

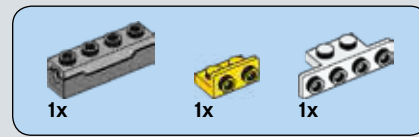
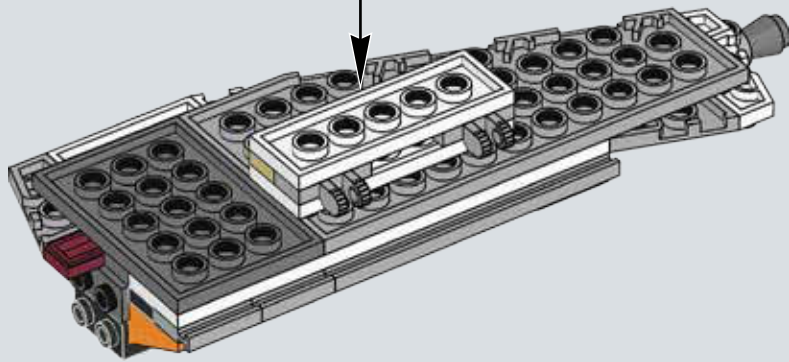
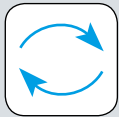
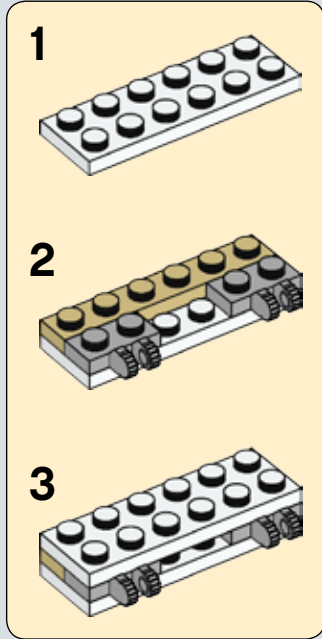

# 45

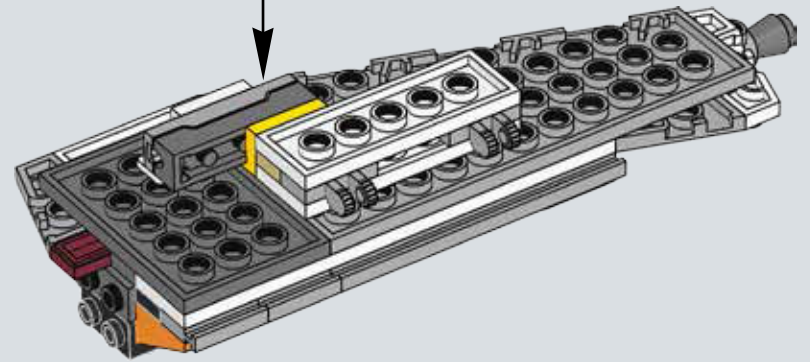
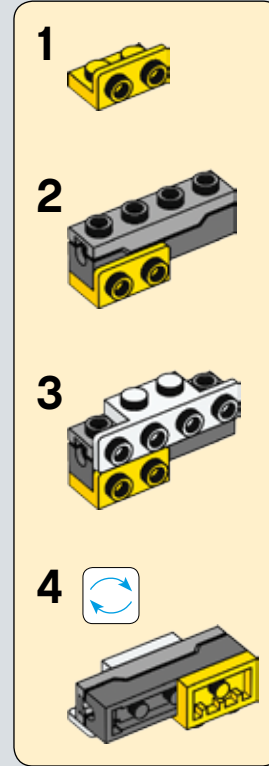

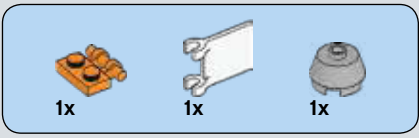

46

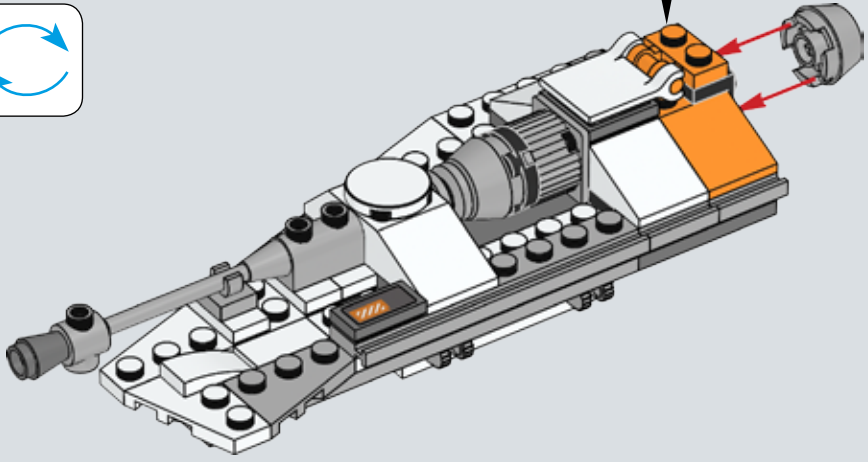
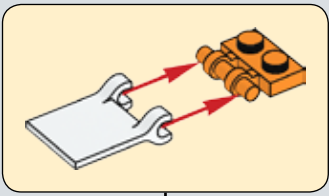

47

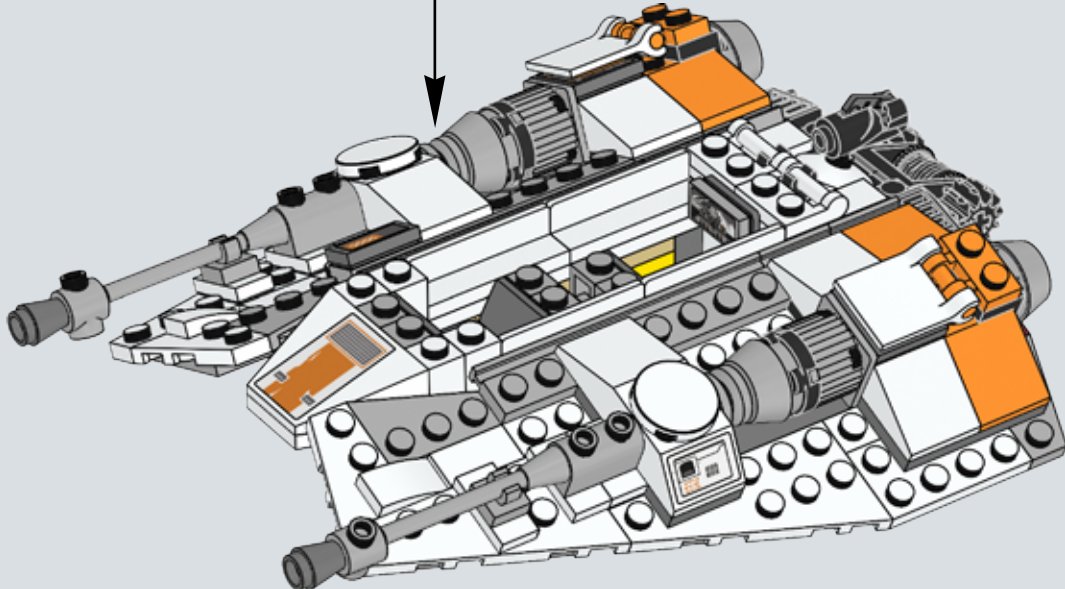



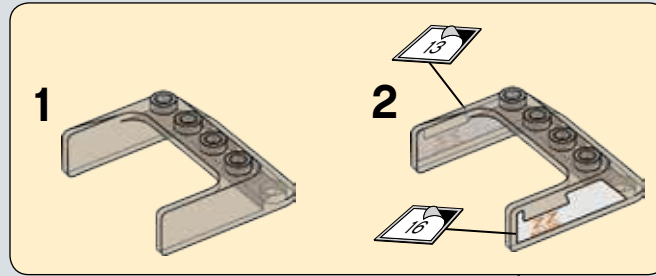
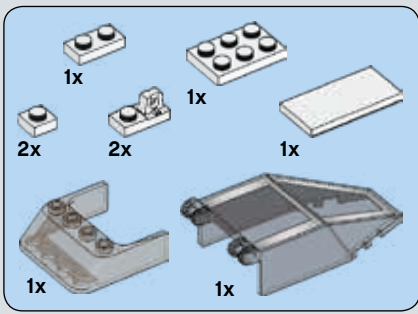

# 48

1



2

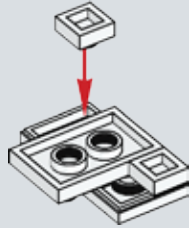

3

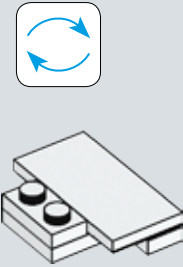

4

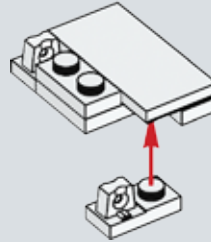

5

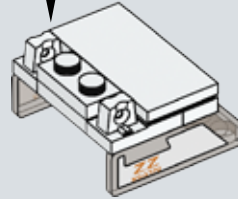

6

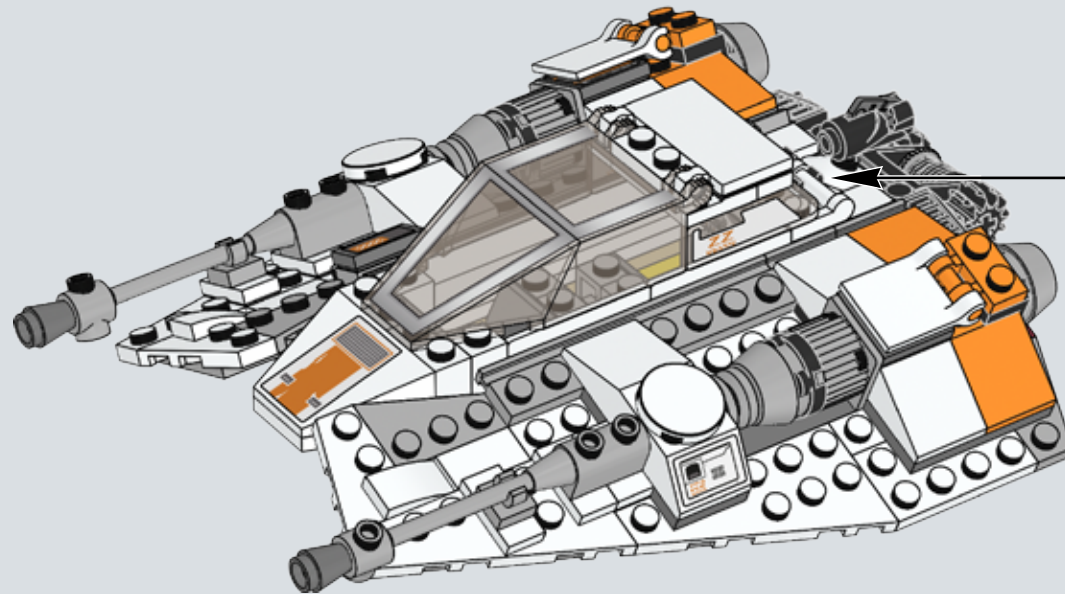
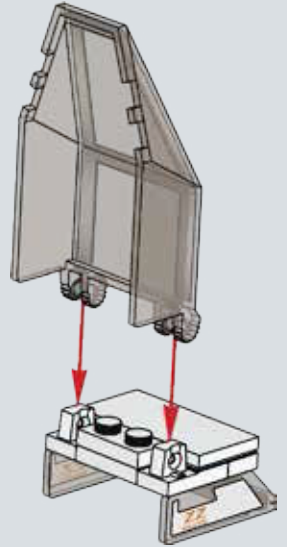

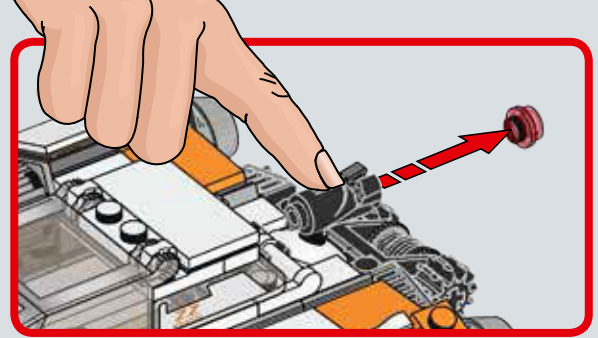
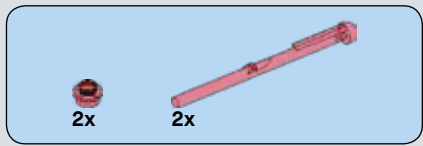

49

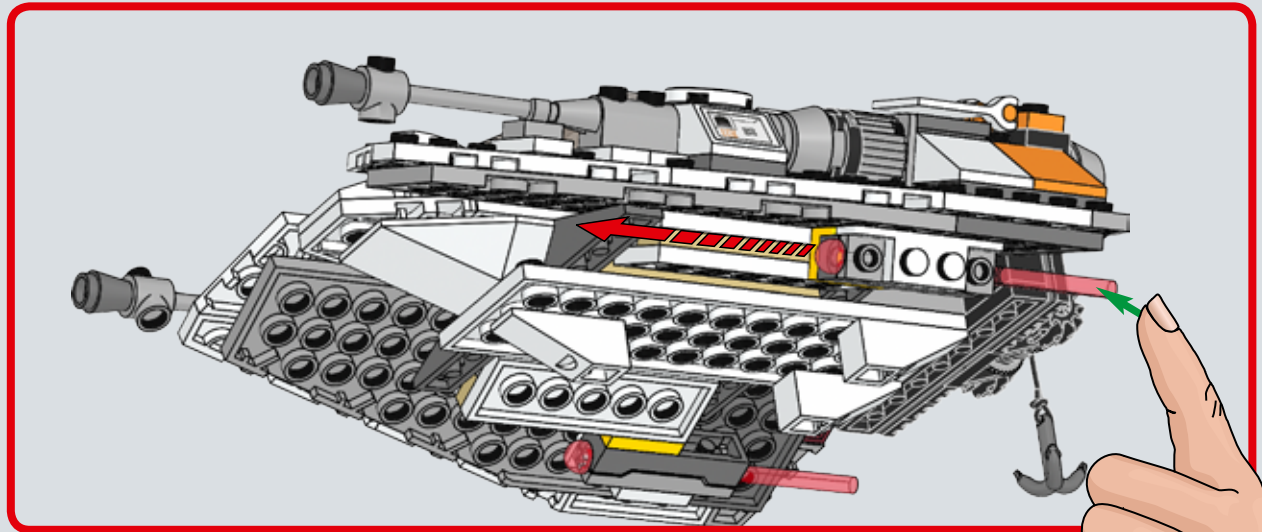
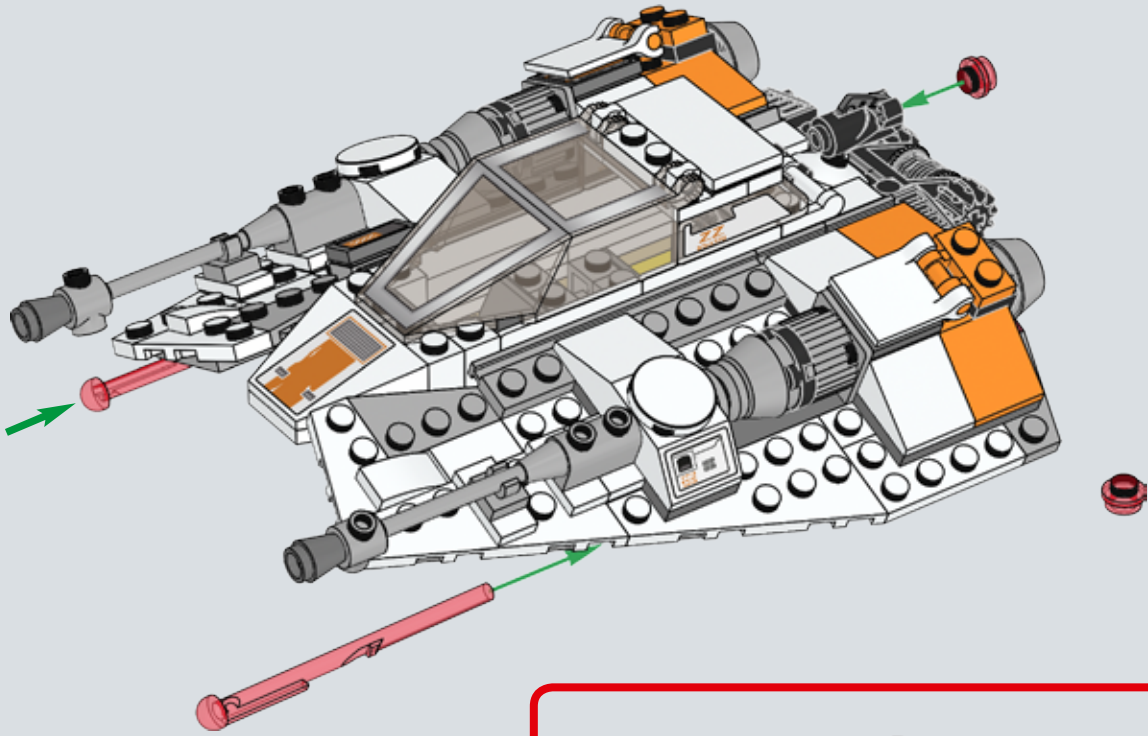

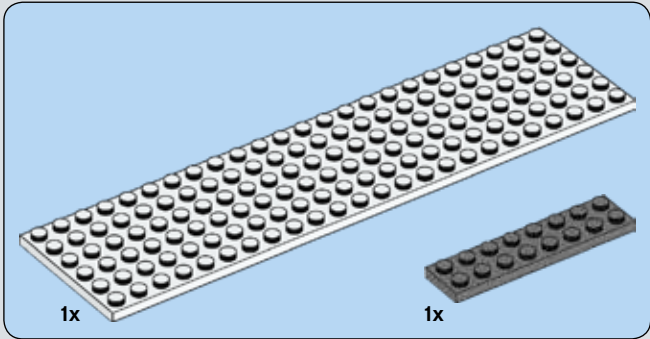
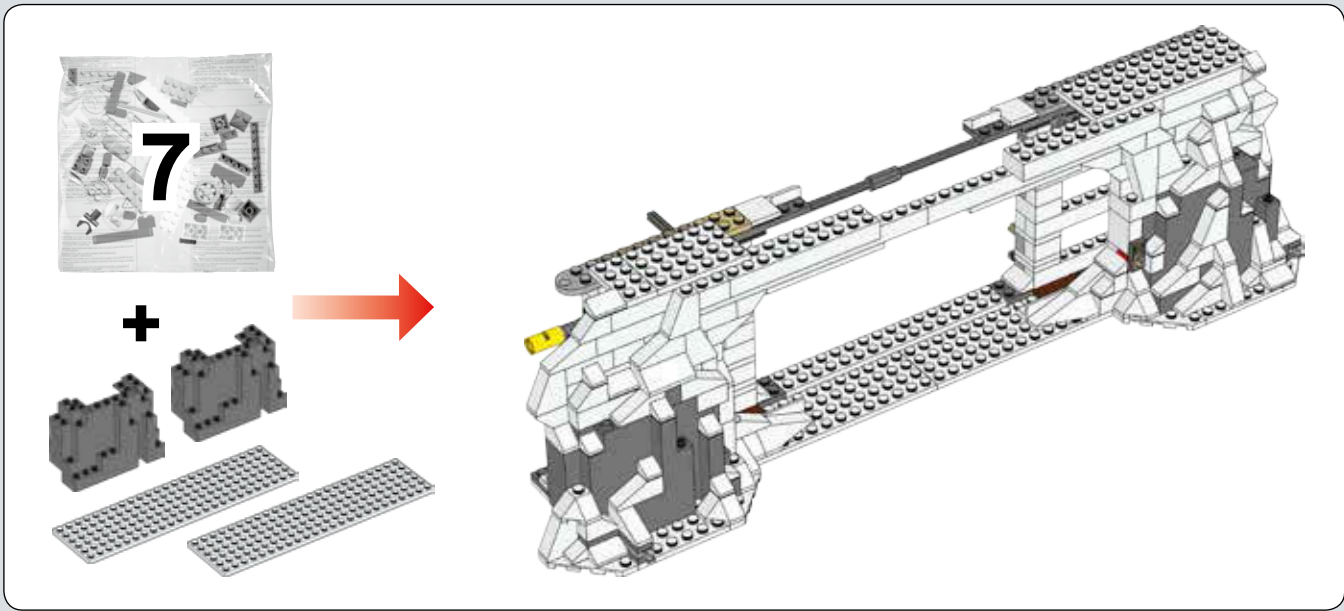

1

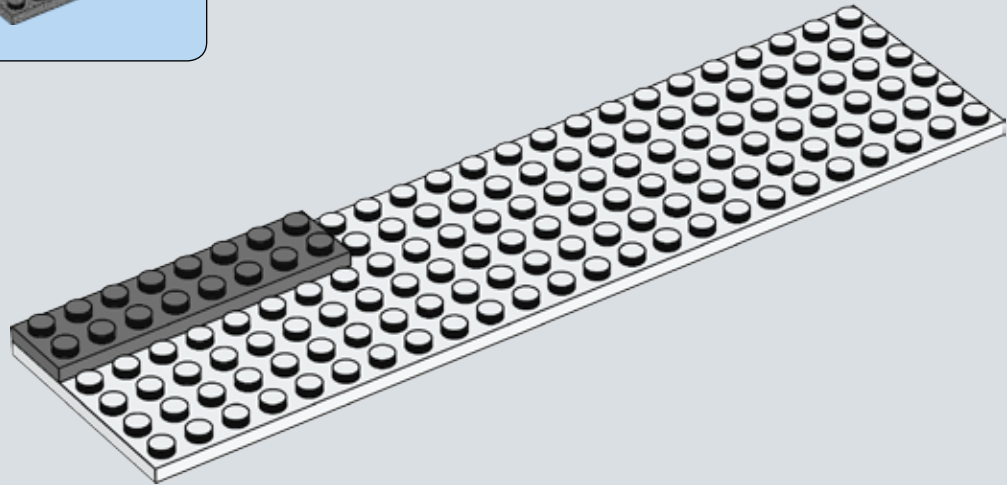

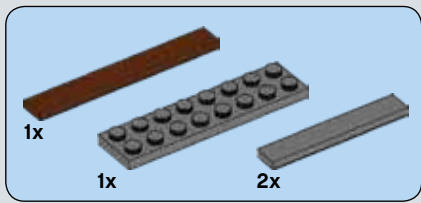

2

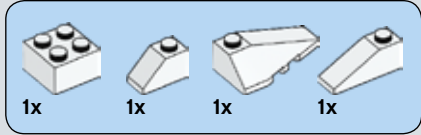
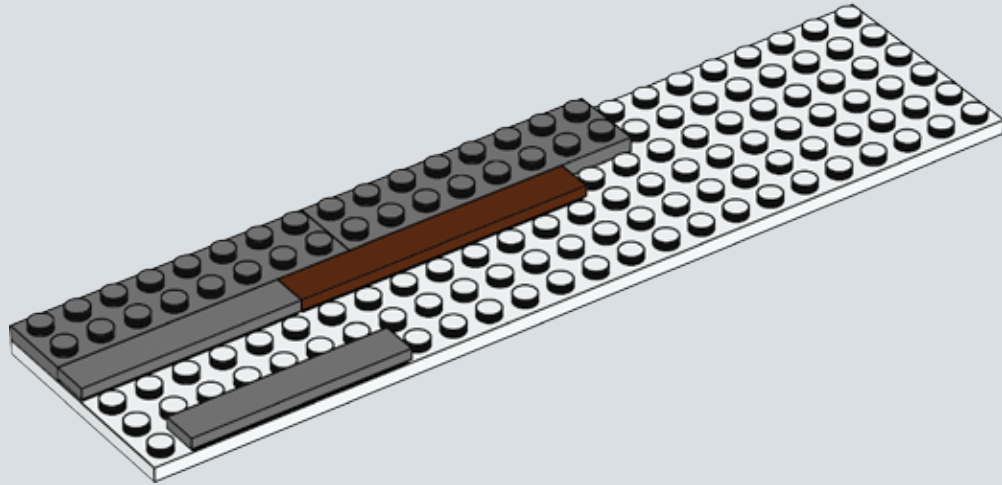

3

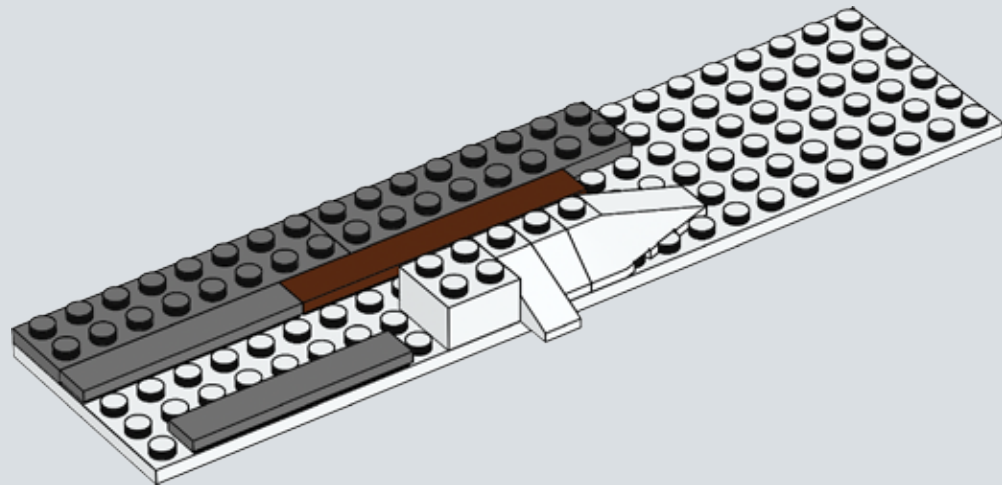



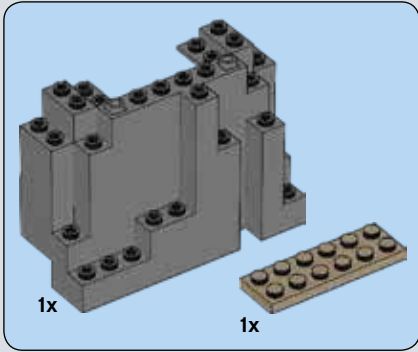
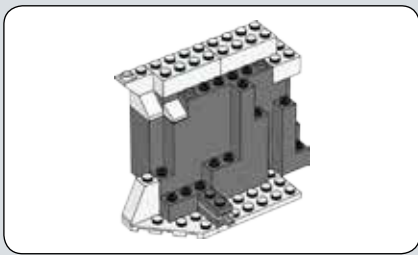

4

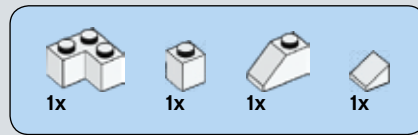
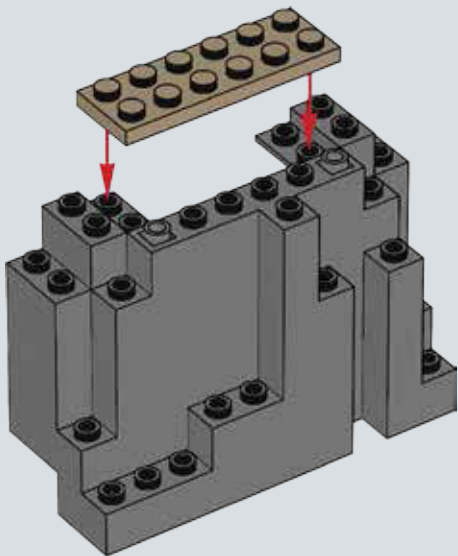

5

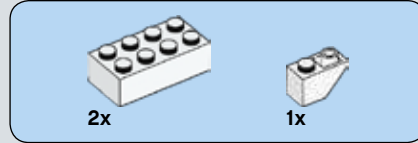
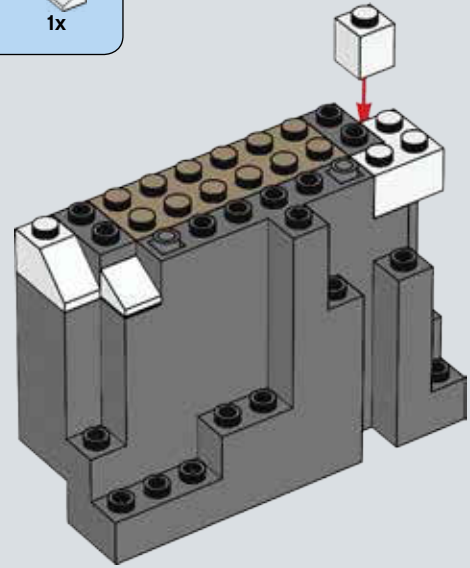

6

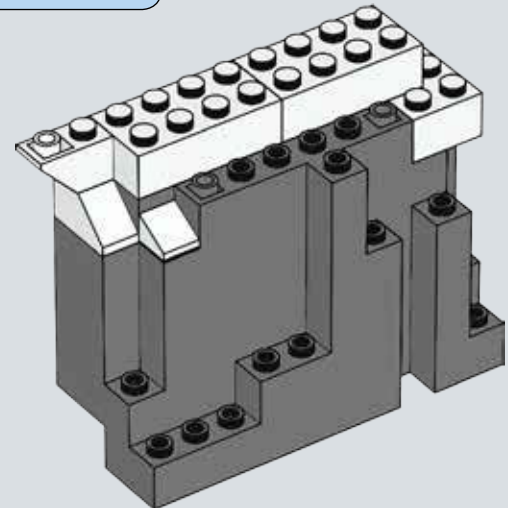

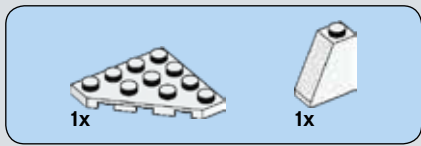

7

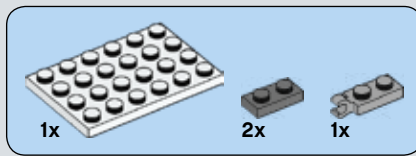
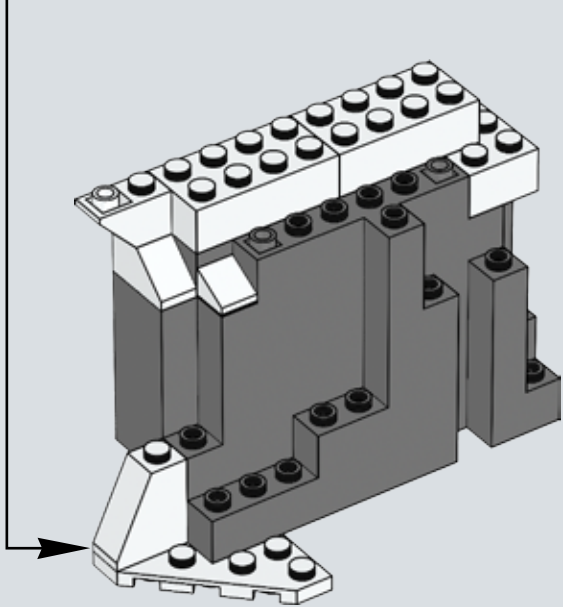
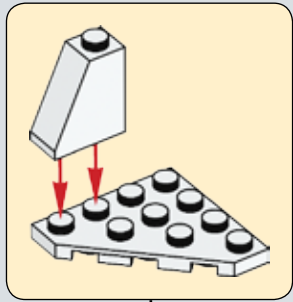

8

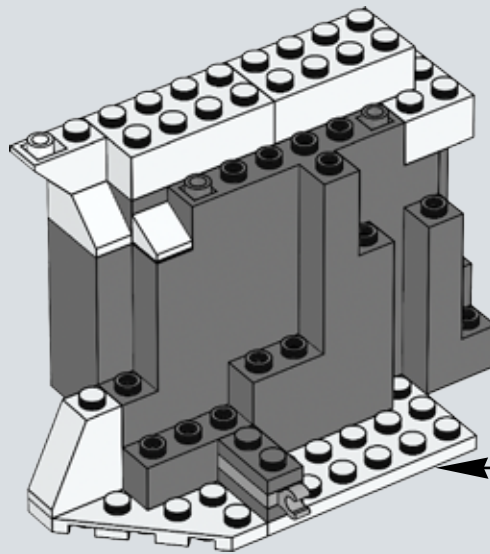
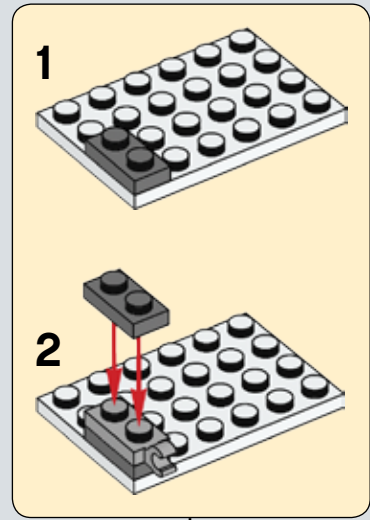



9

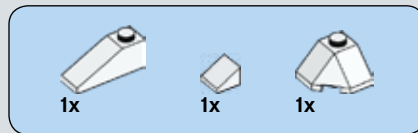
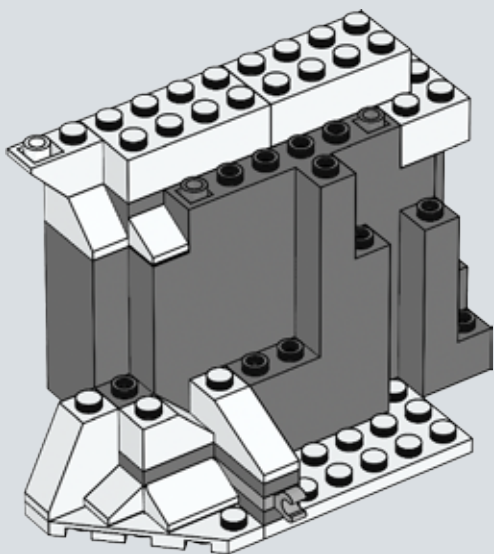

10

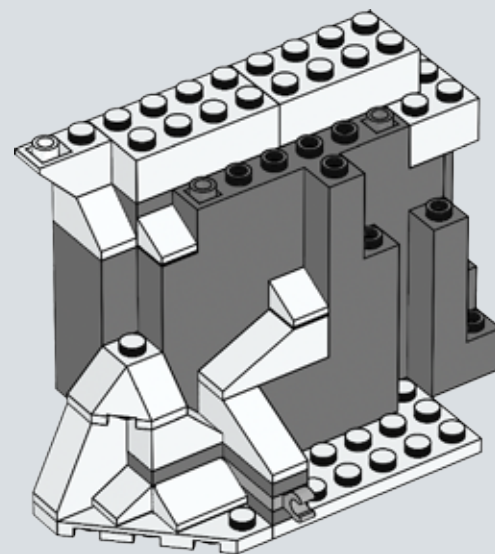

# 11

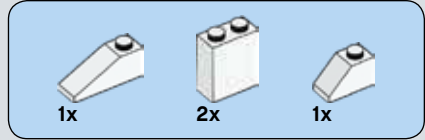
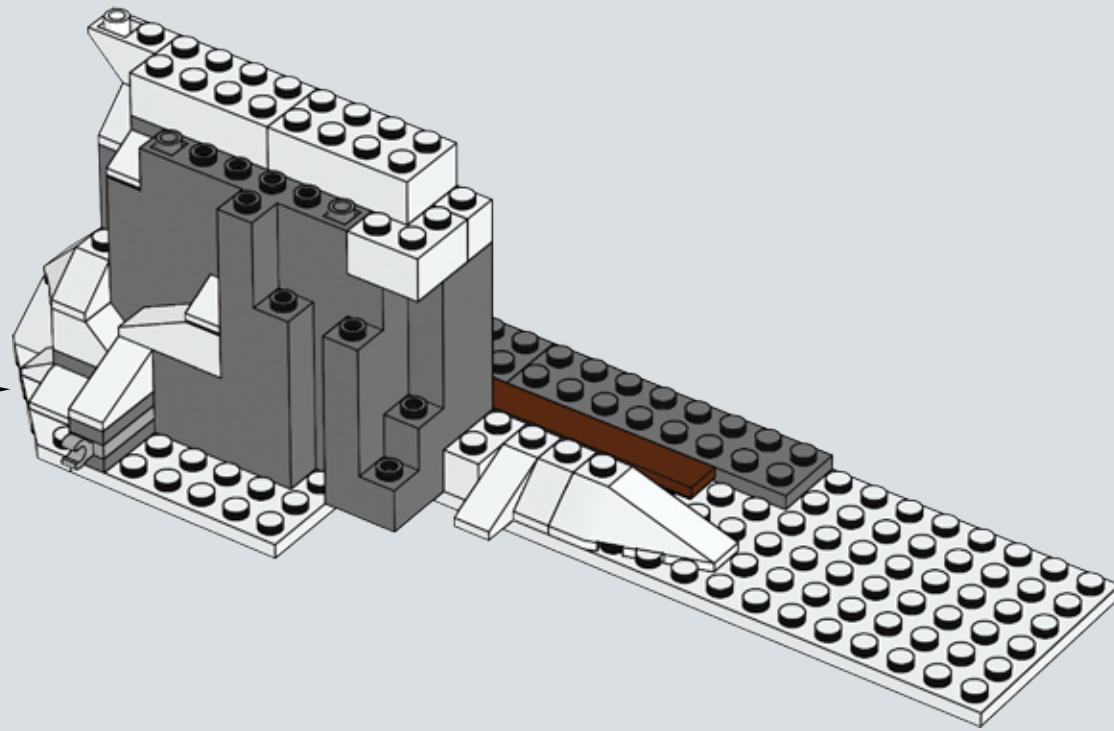
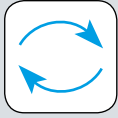

# 12

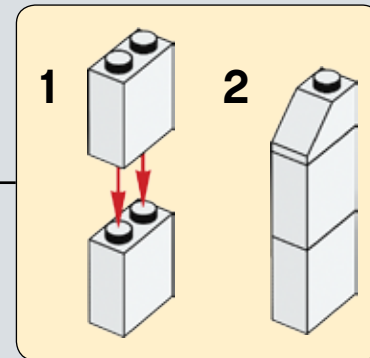
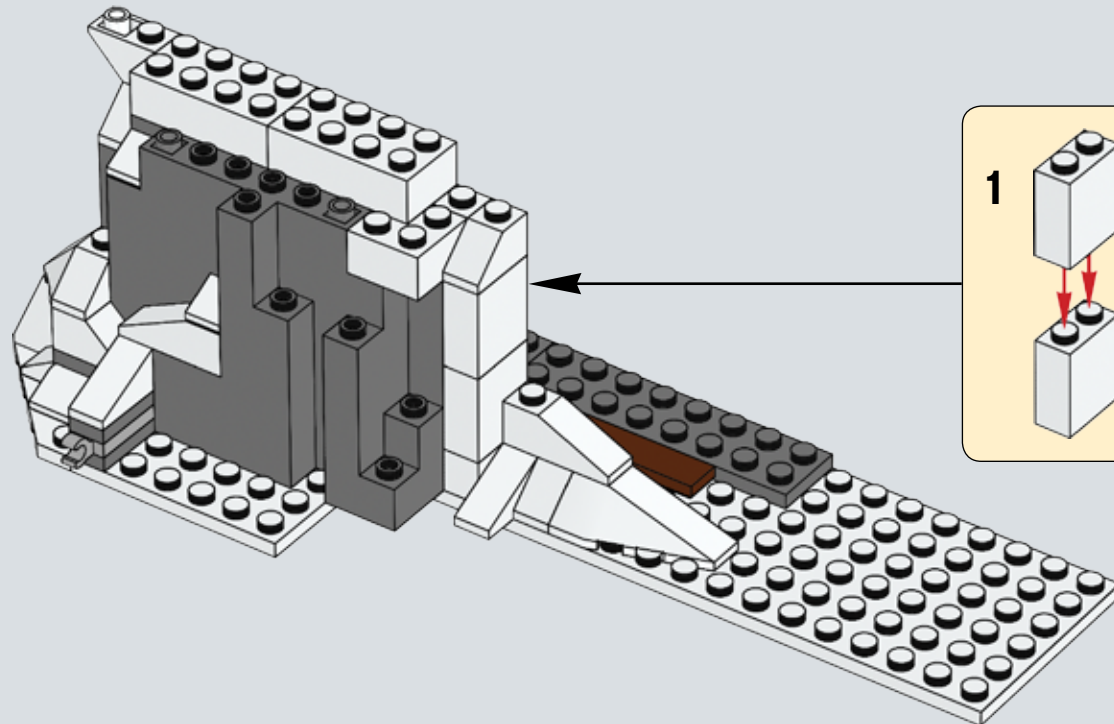



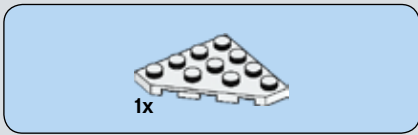

13

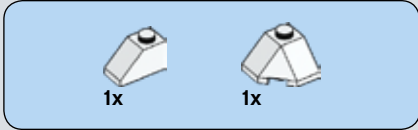
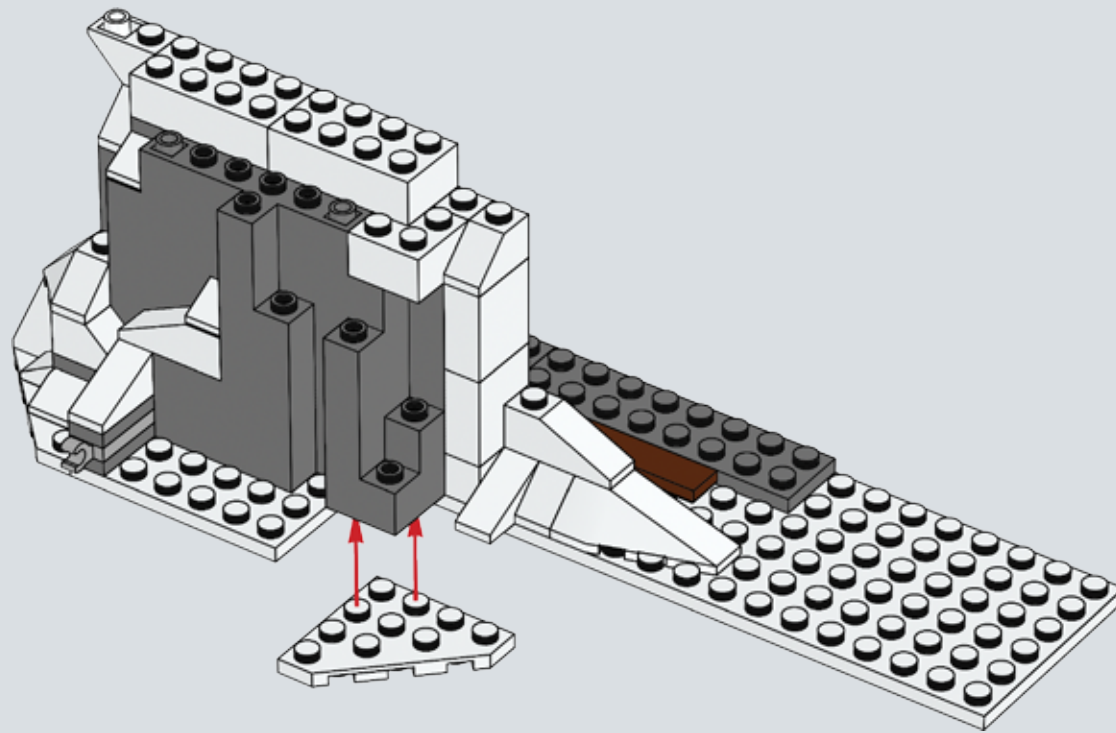

14

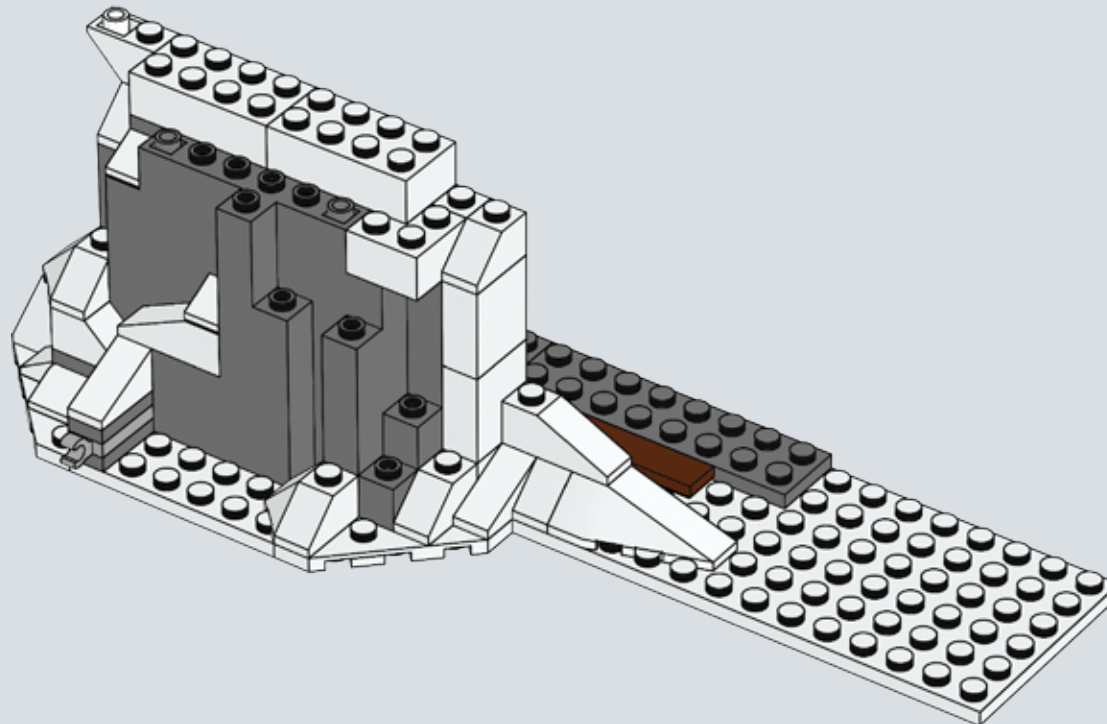

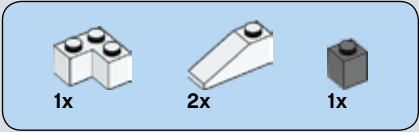

15

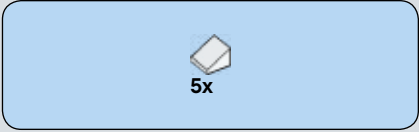
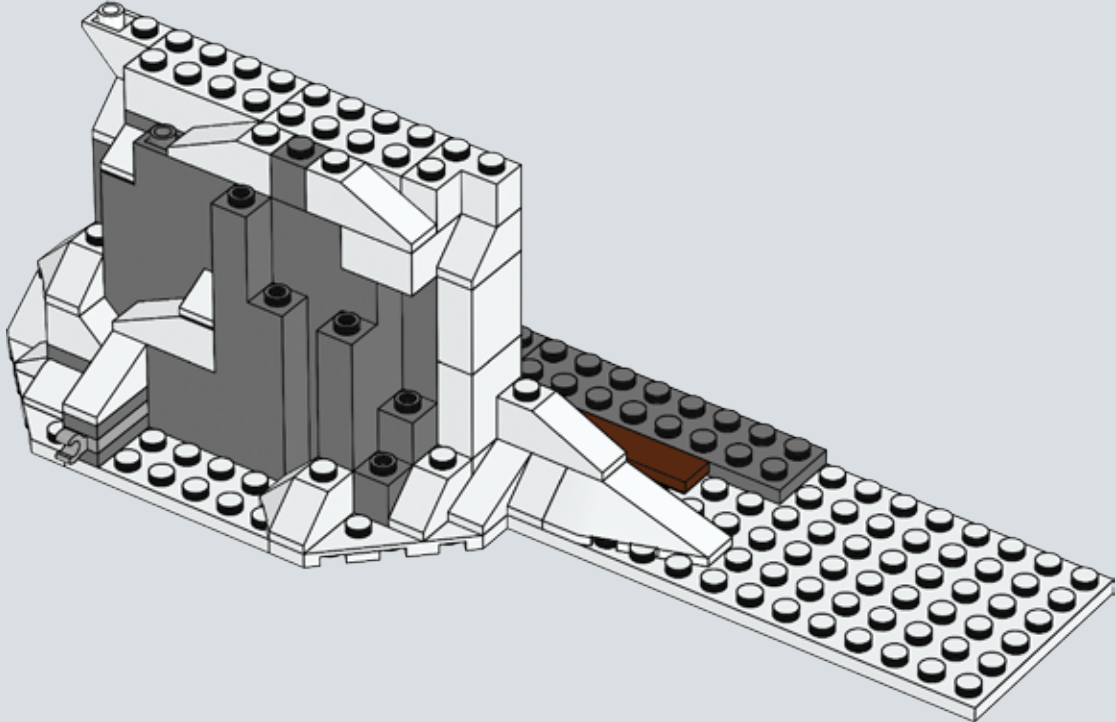

16

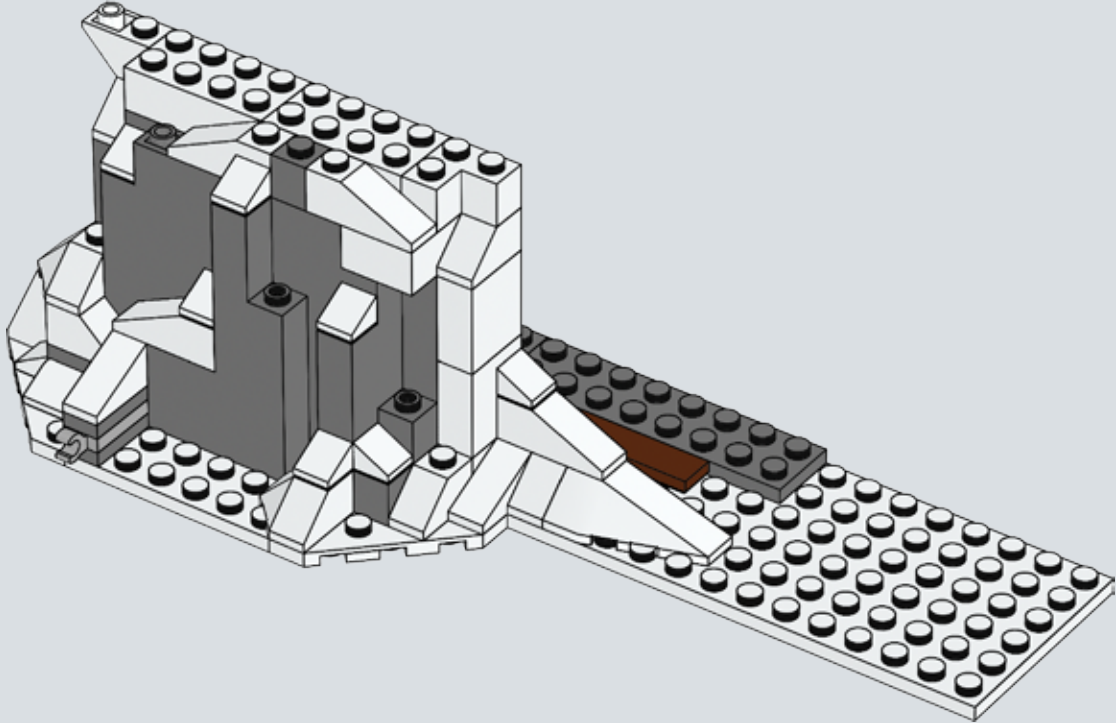

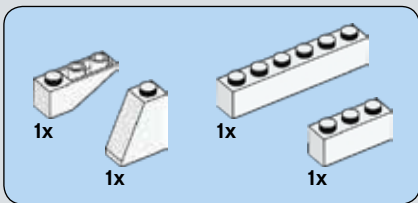

17

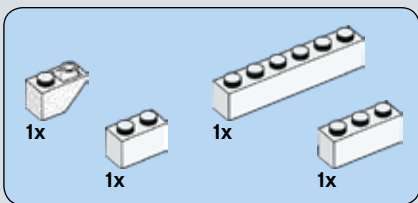
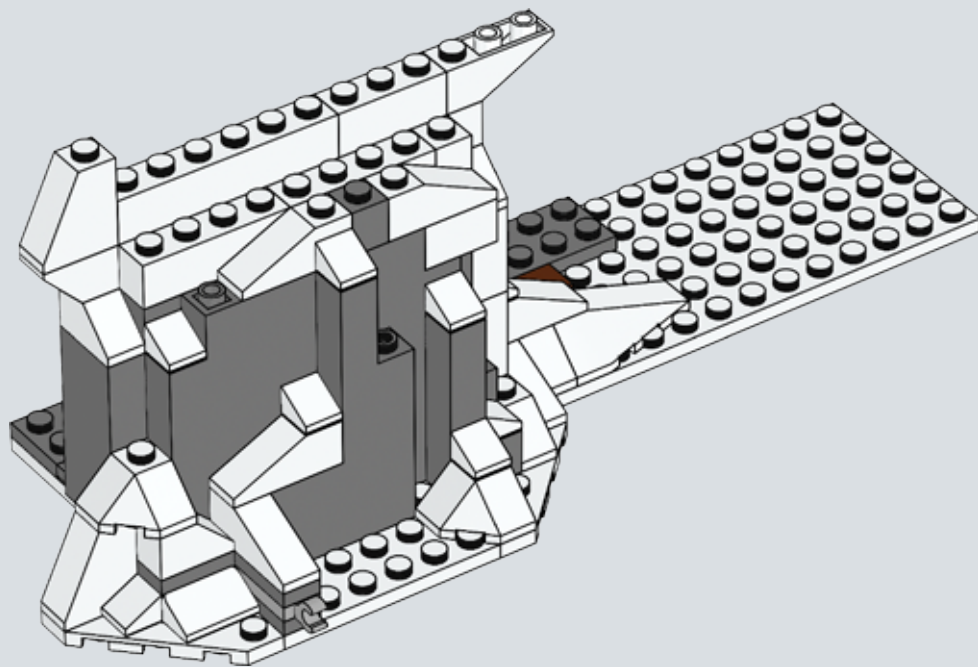

18

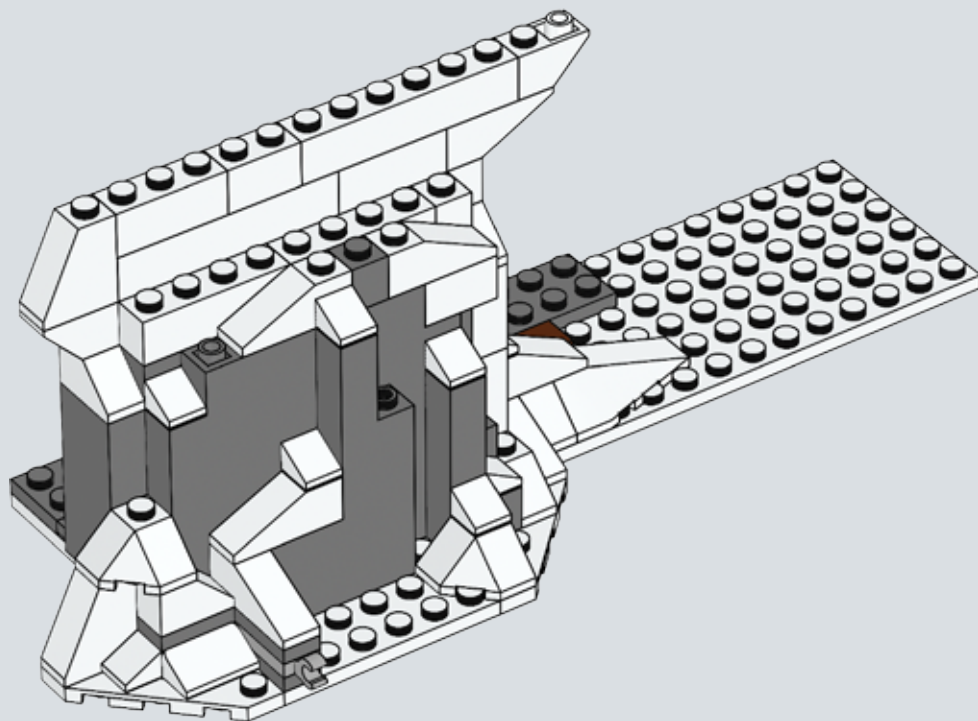

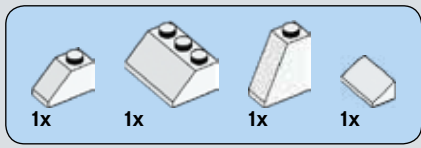

19

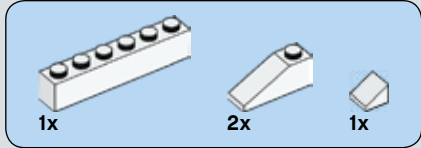
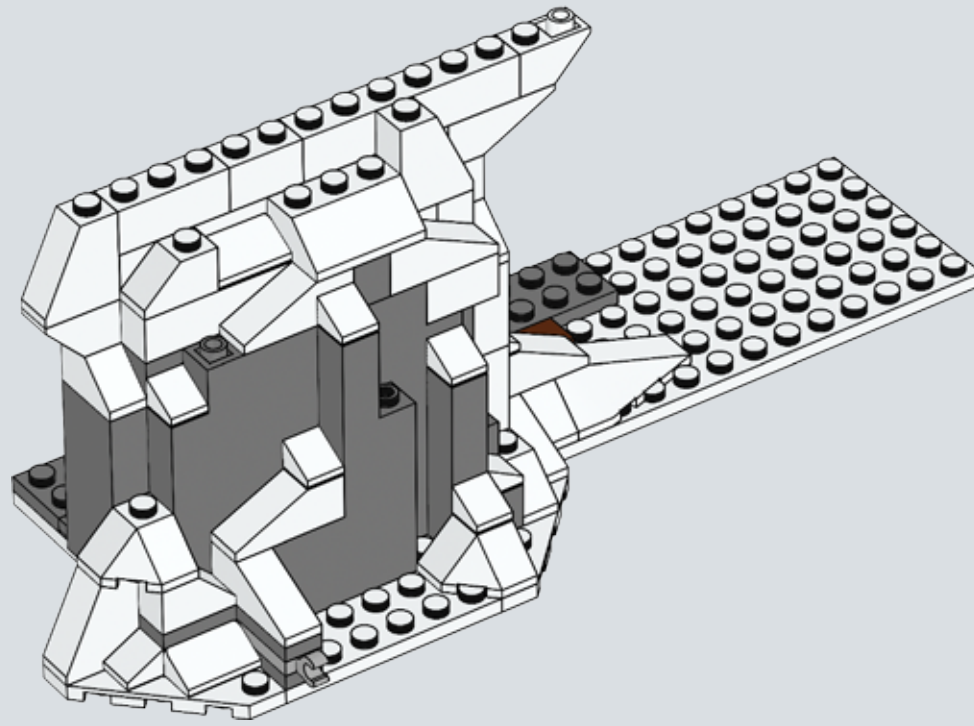

20

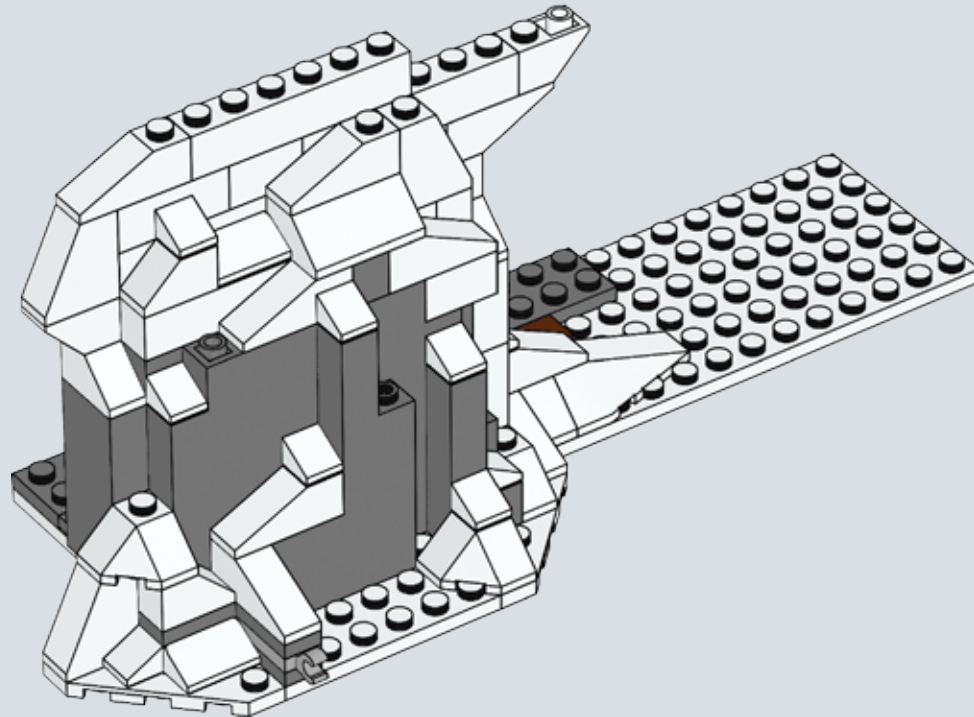



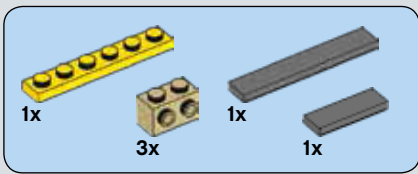

# 21

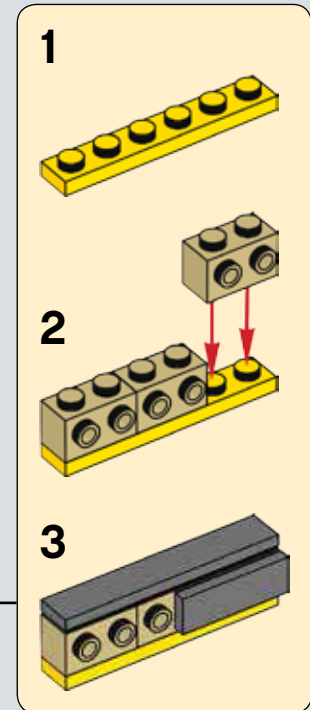
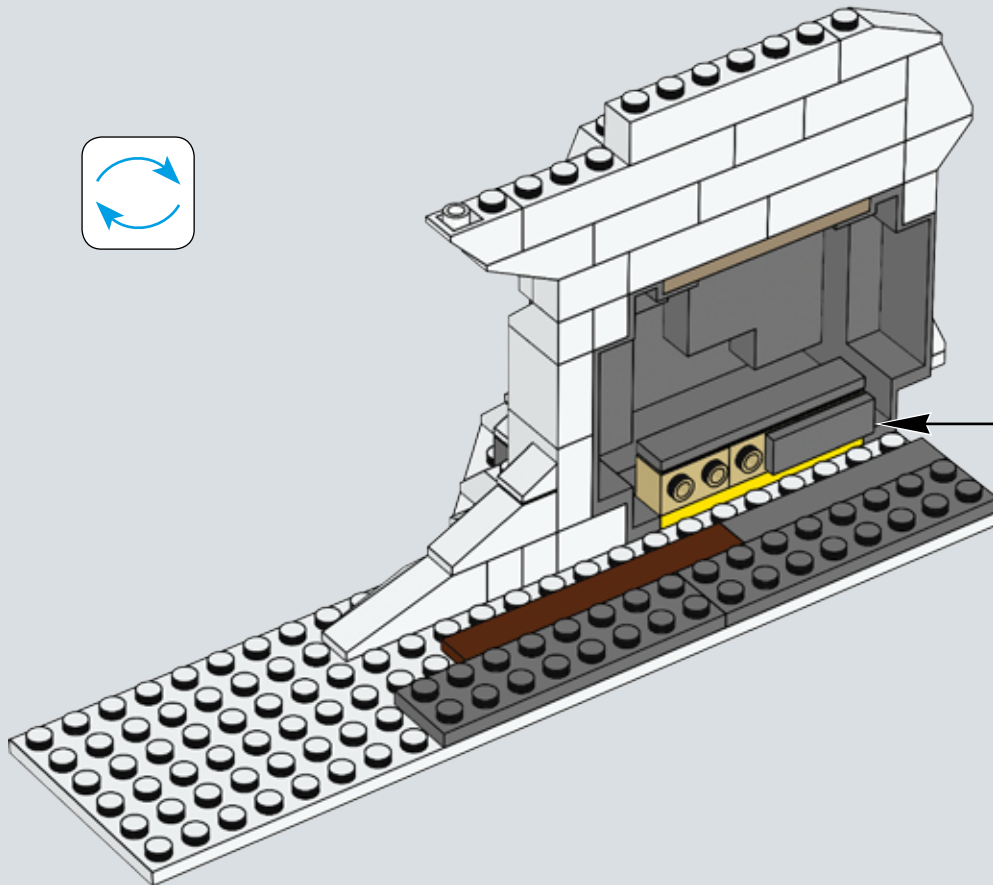
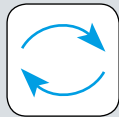

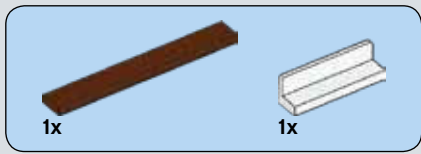

22

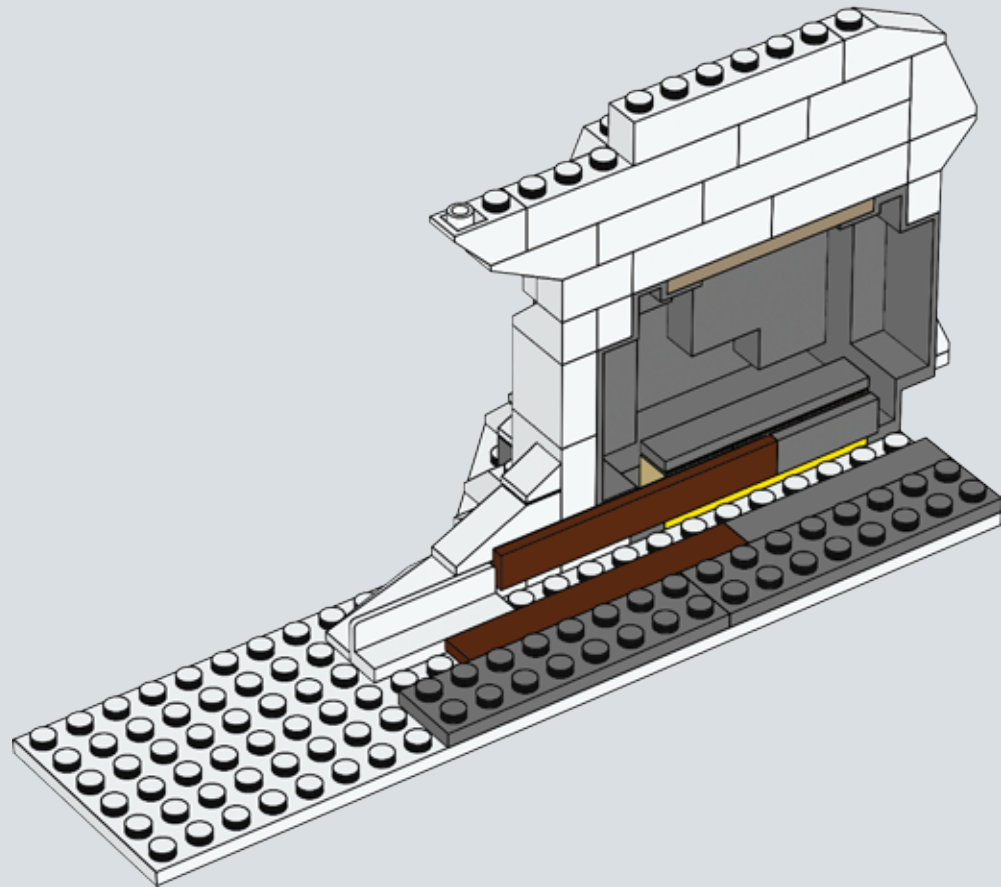

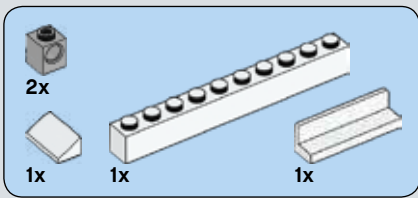

23

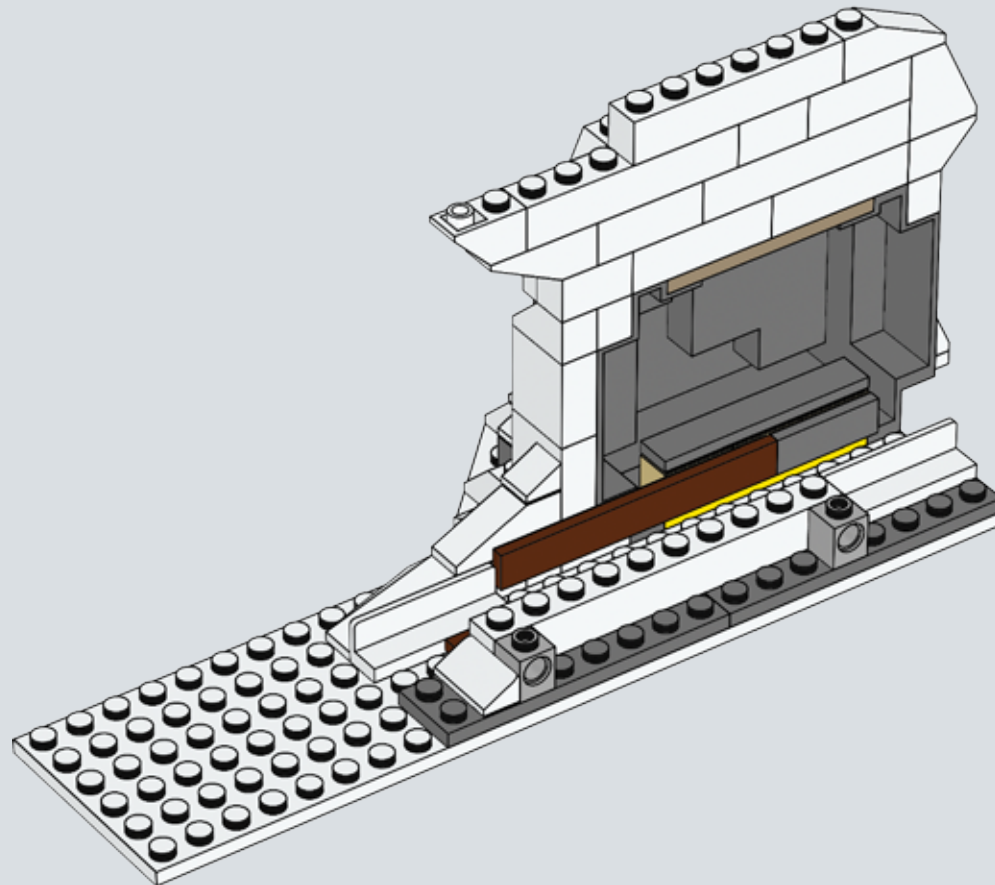

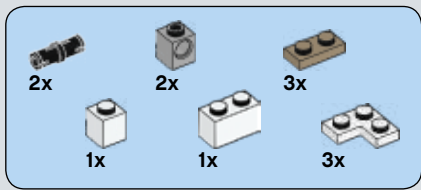

# 24

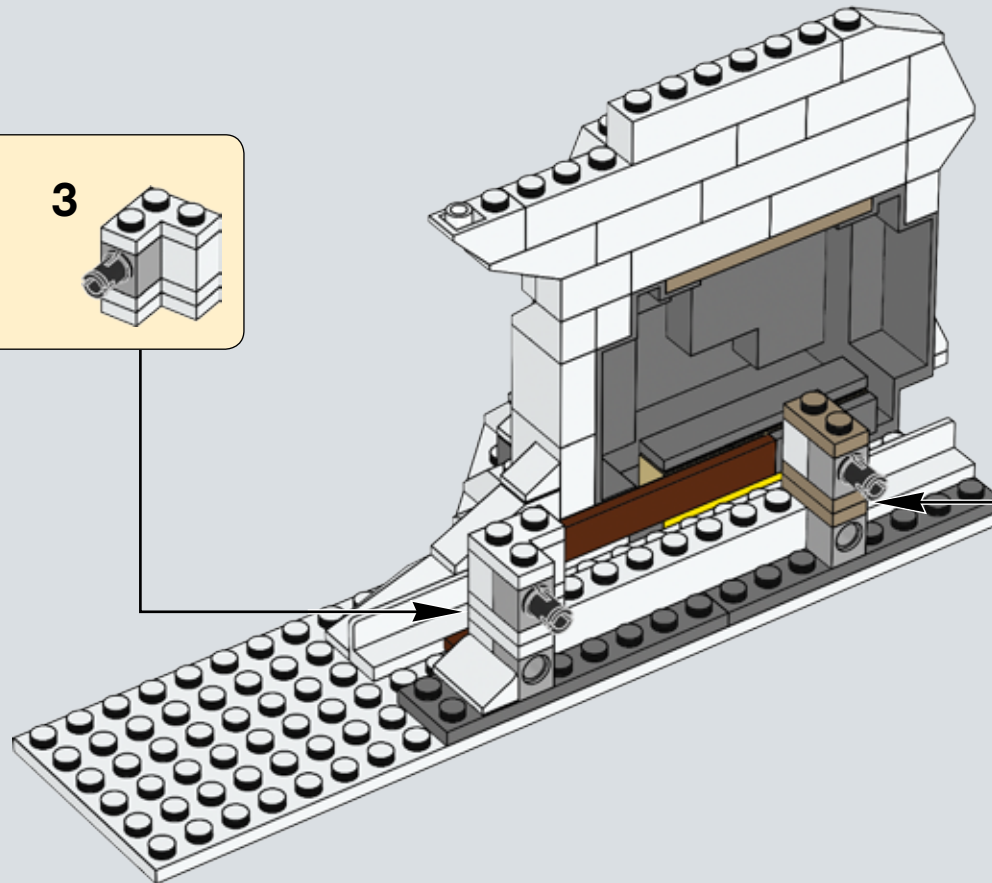
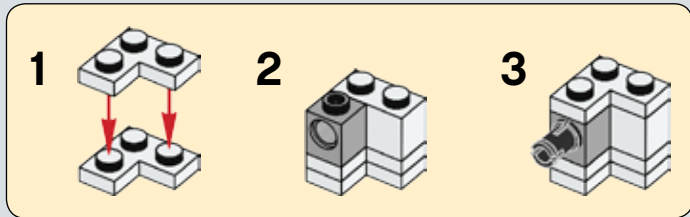
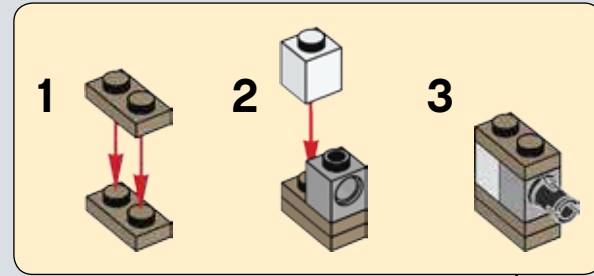



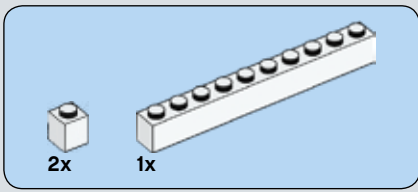

25

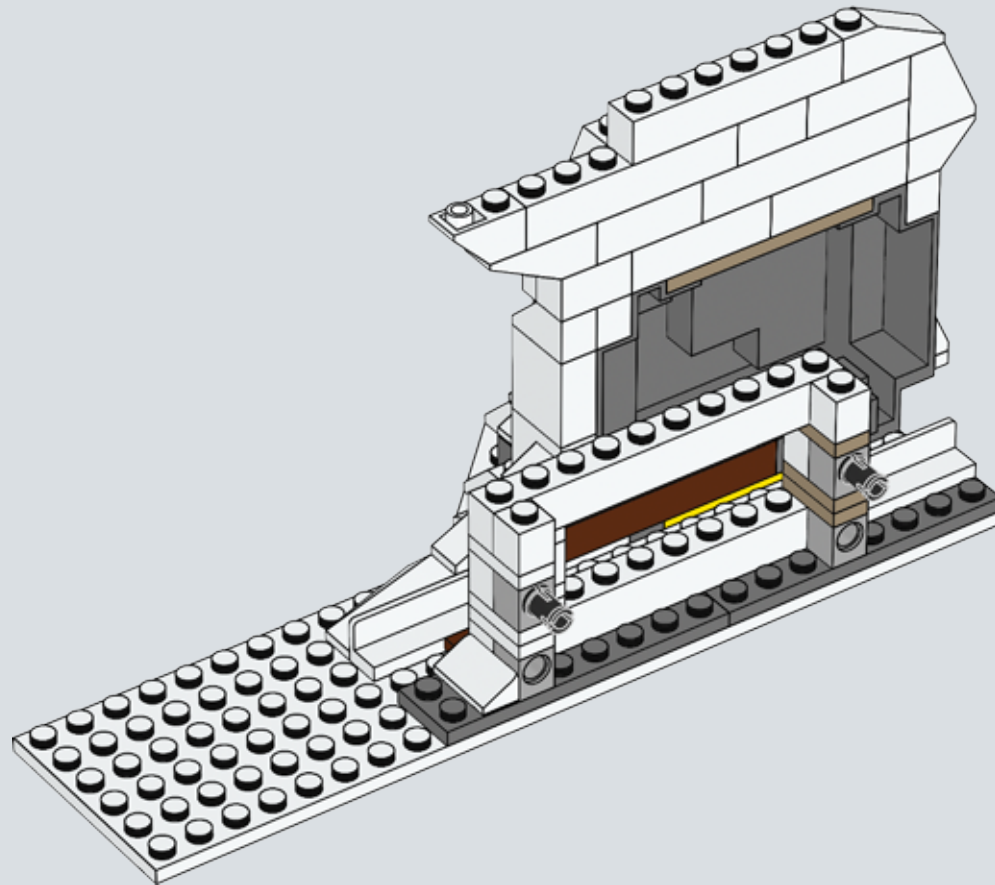

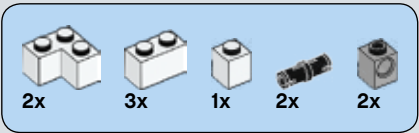

# 26

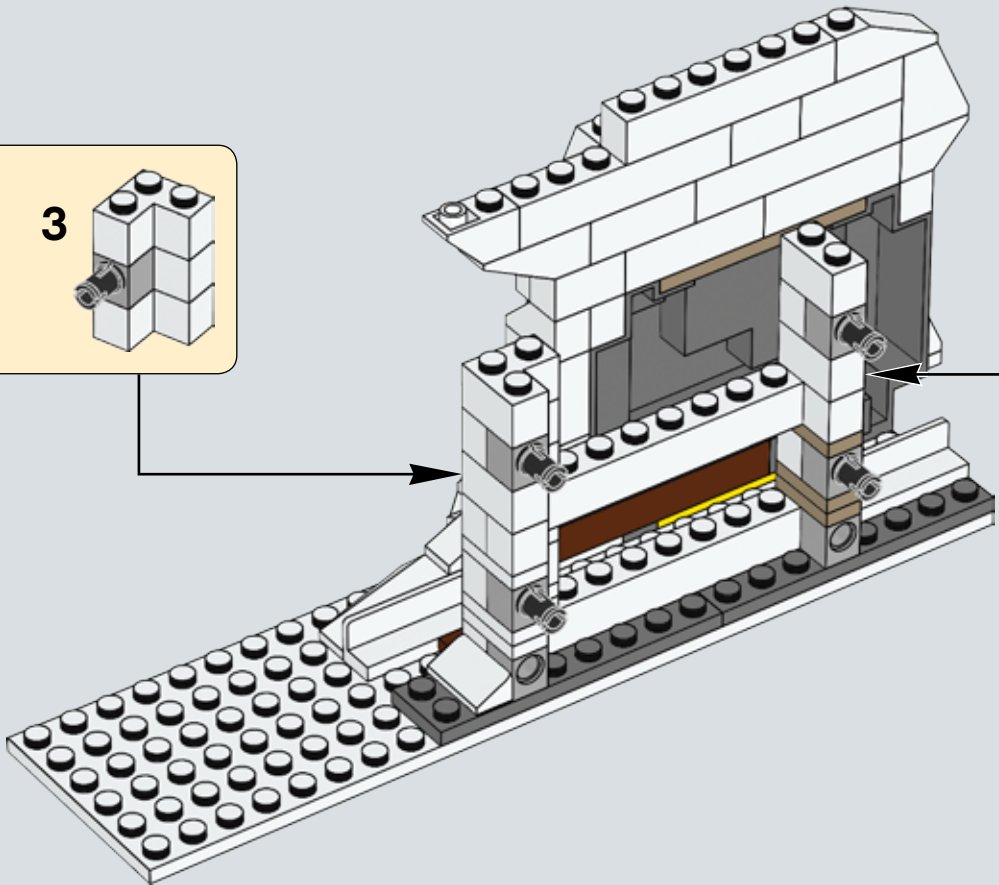
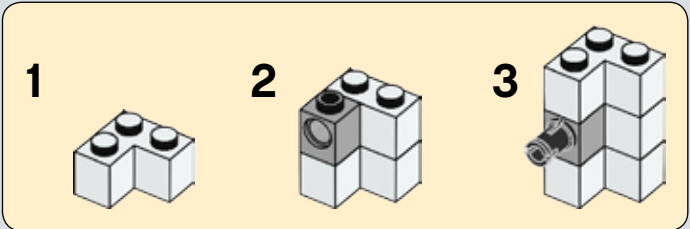
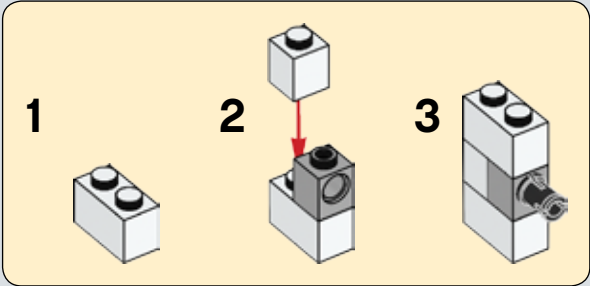

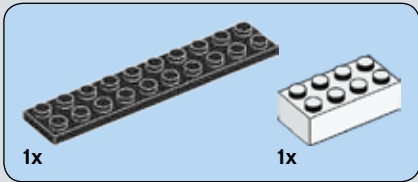
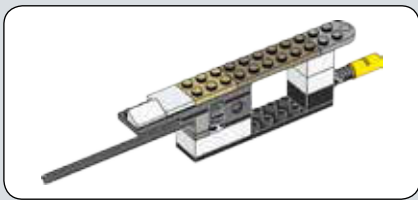

27

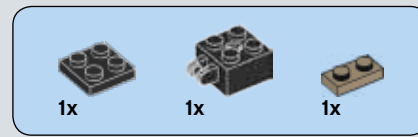
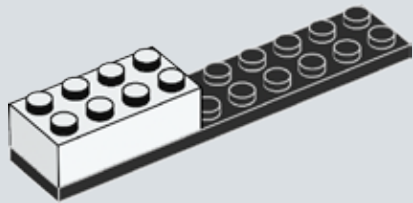

28

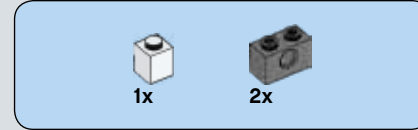
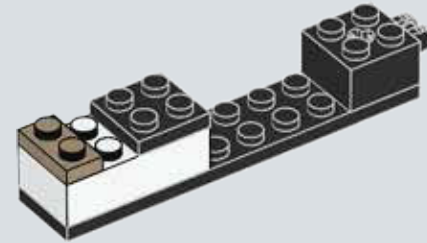

29

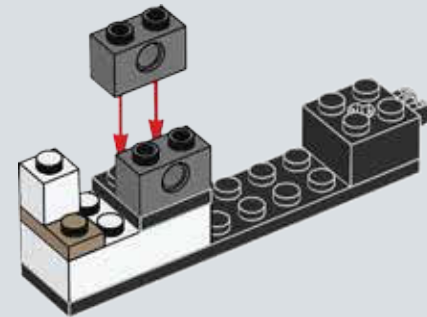

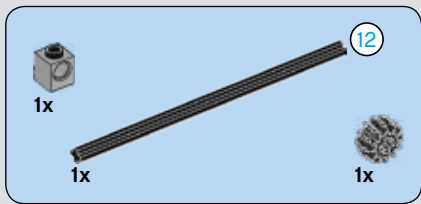

30

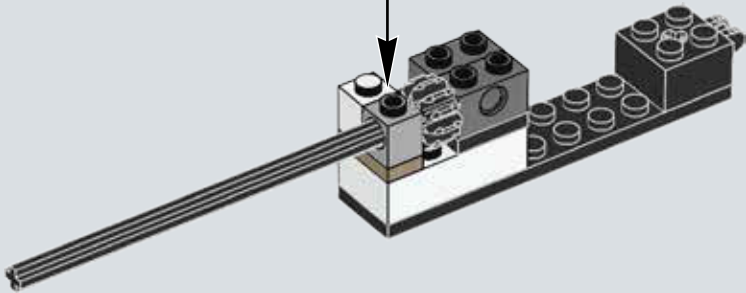
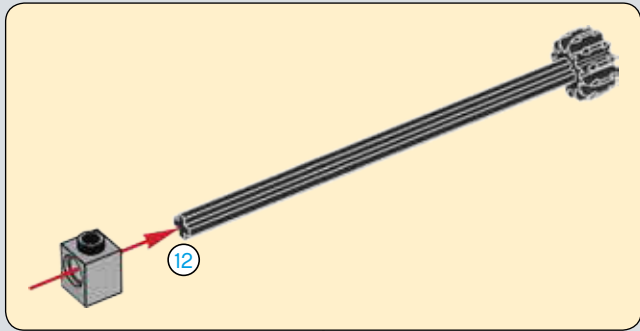

31

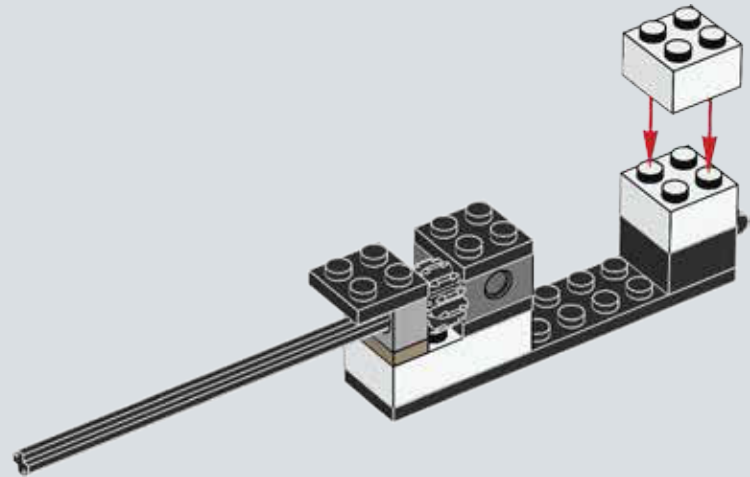



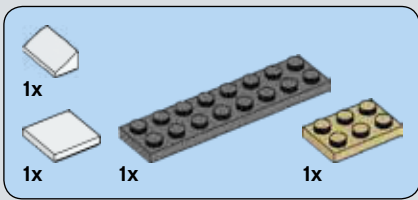

# 32

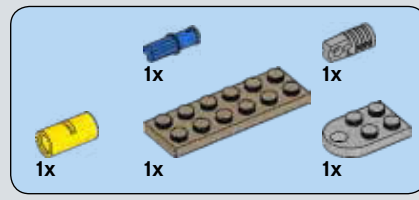
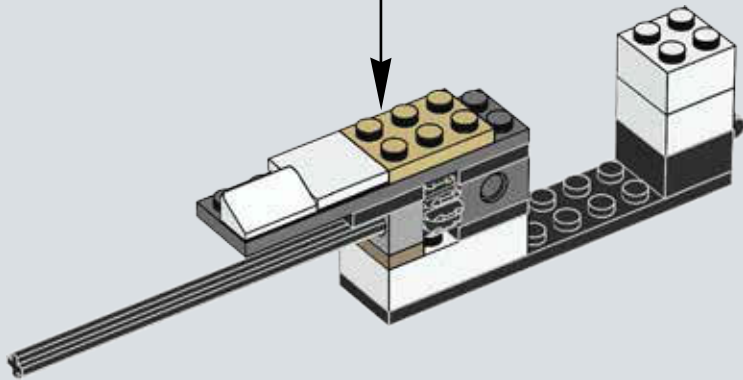
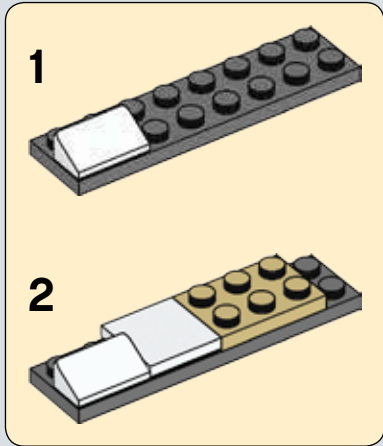

# 33

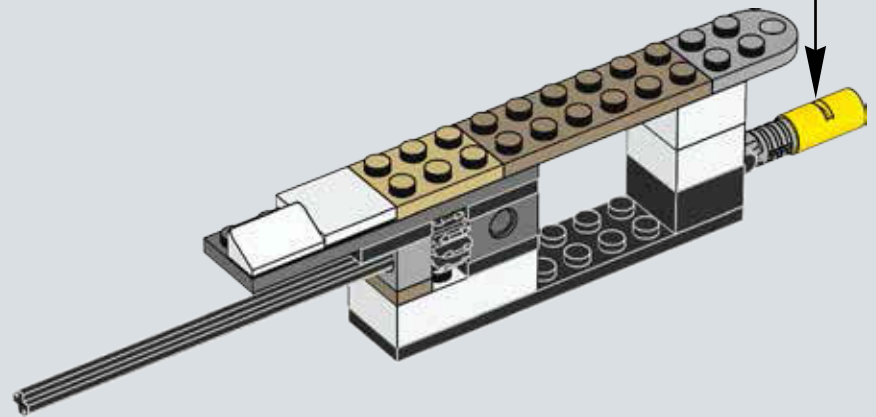
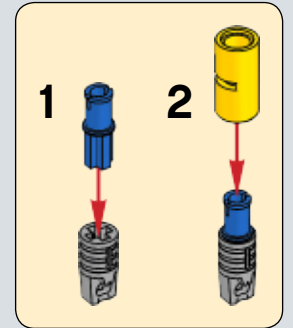

34

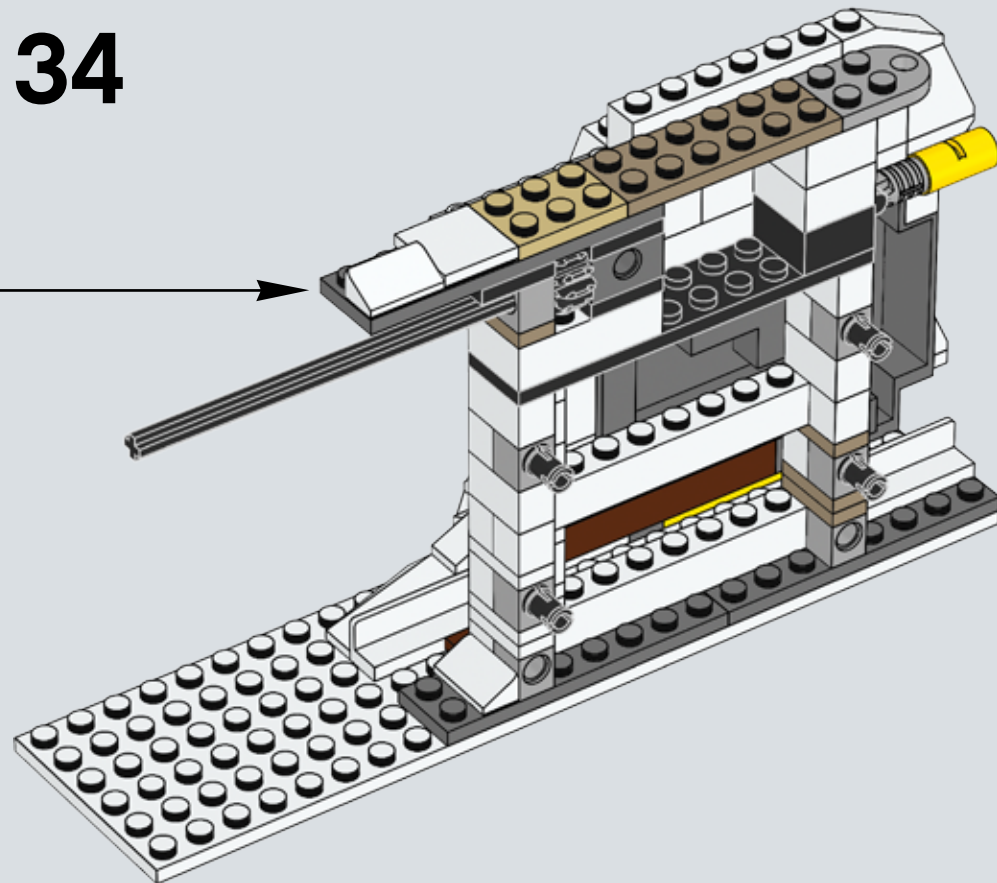

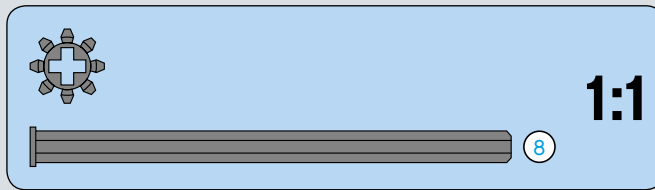
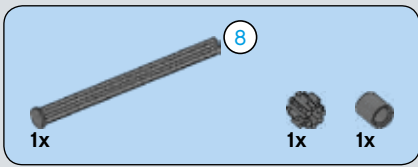

35

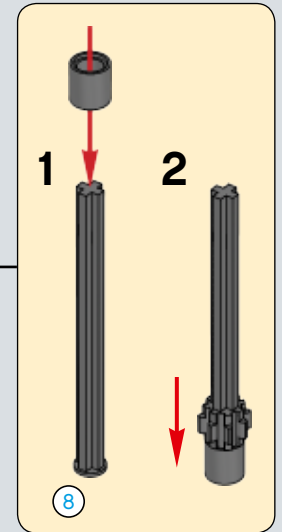
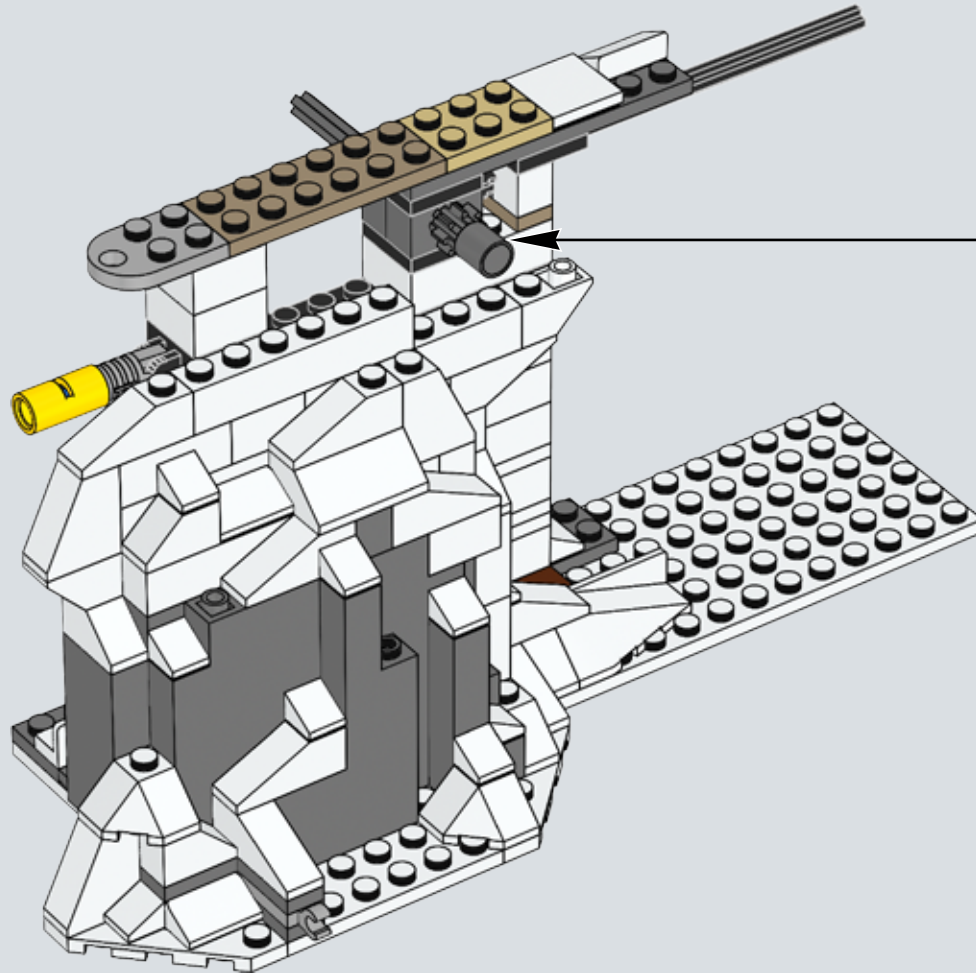
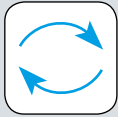

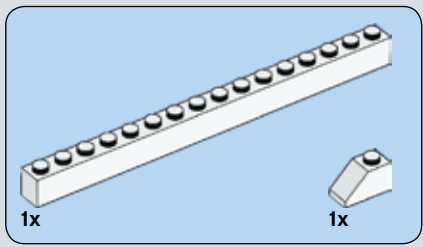

# 36

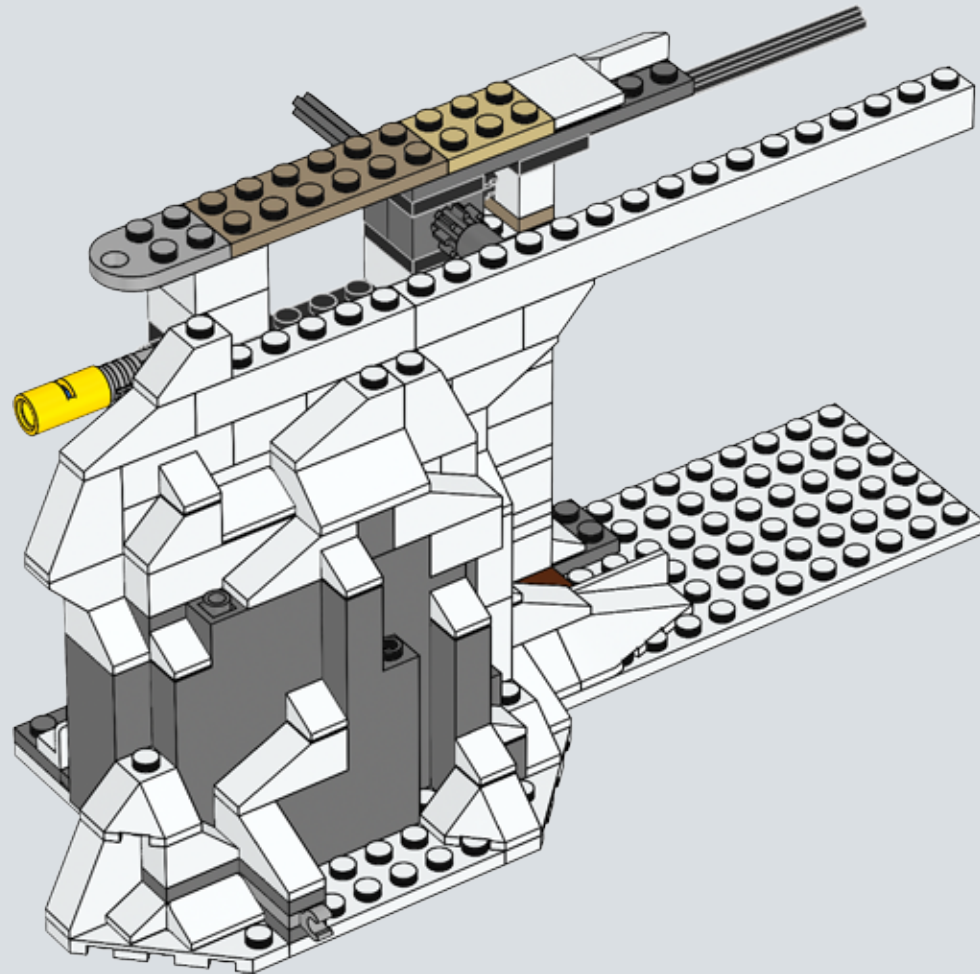



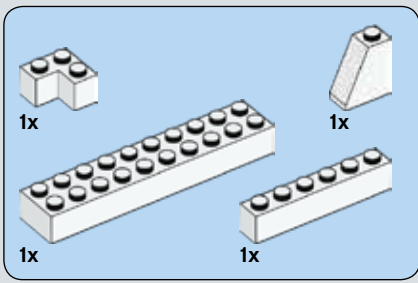

37

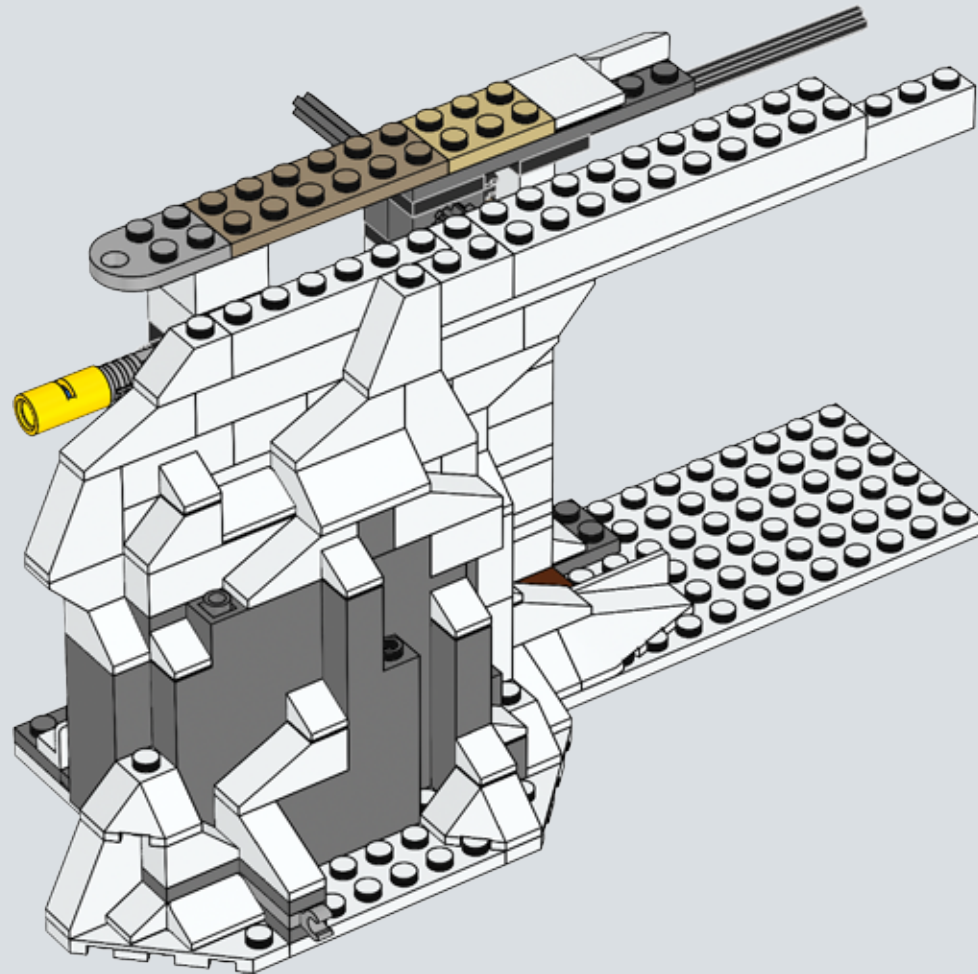

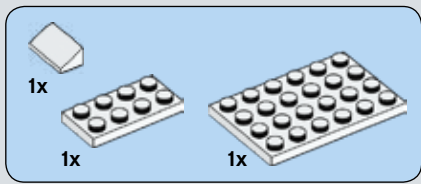

38

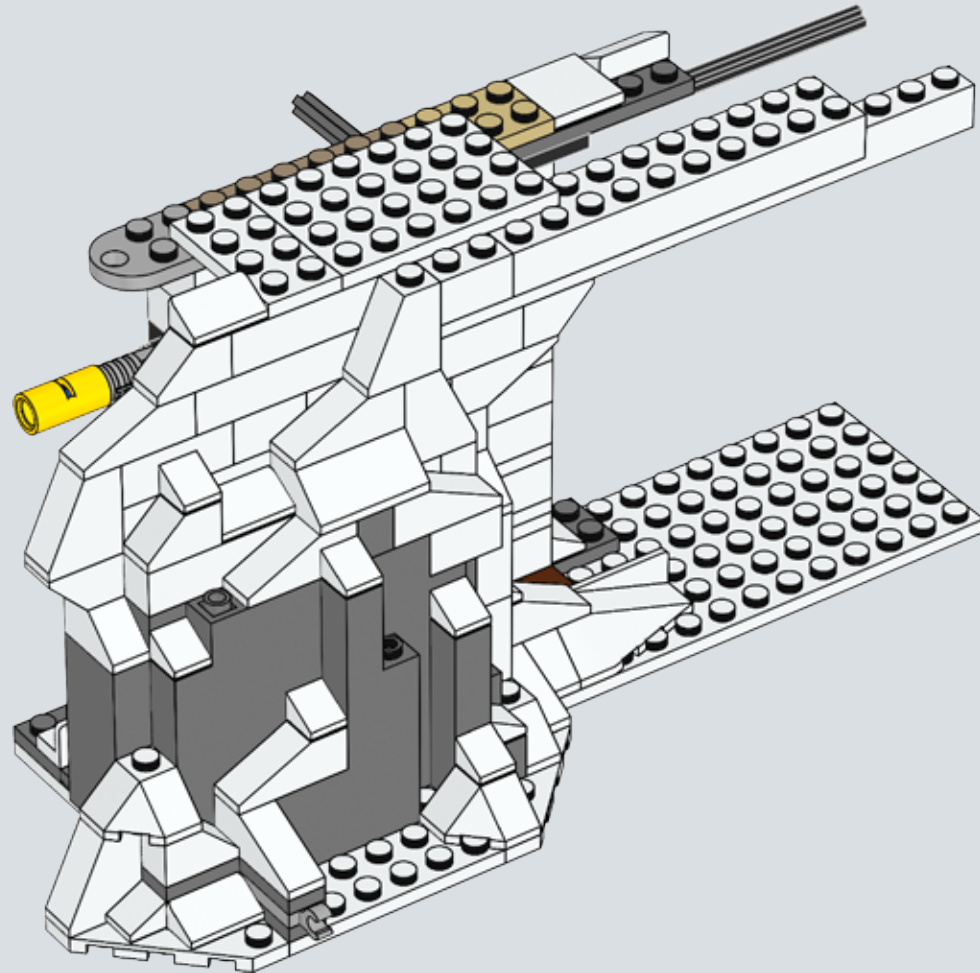

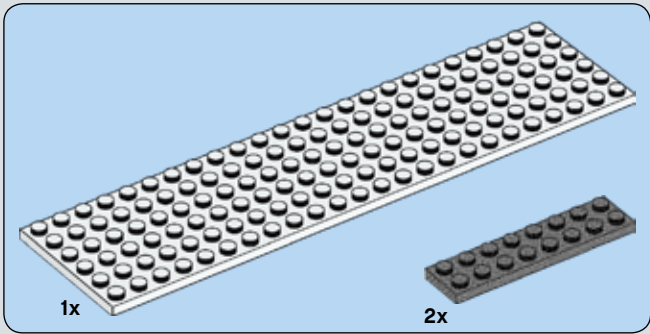
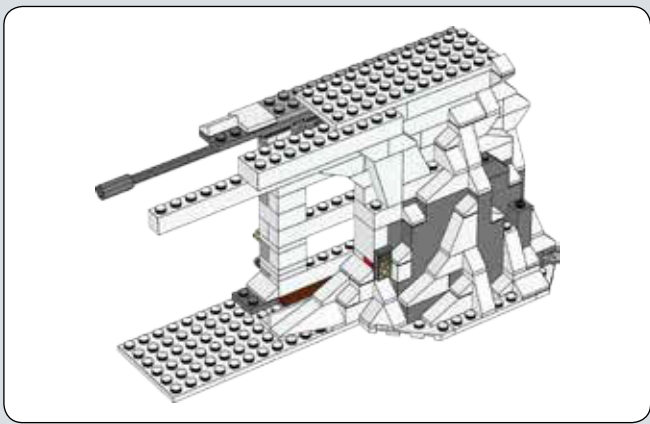

**39**

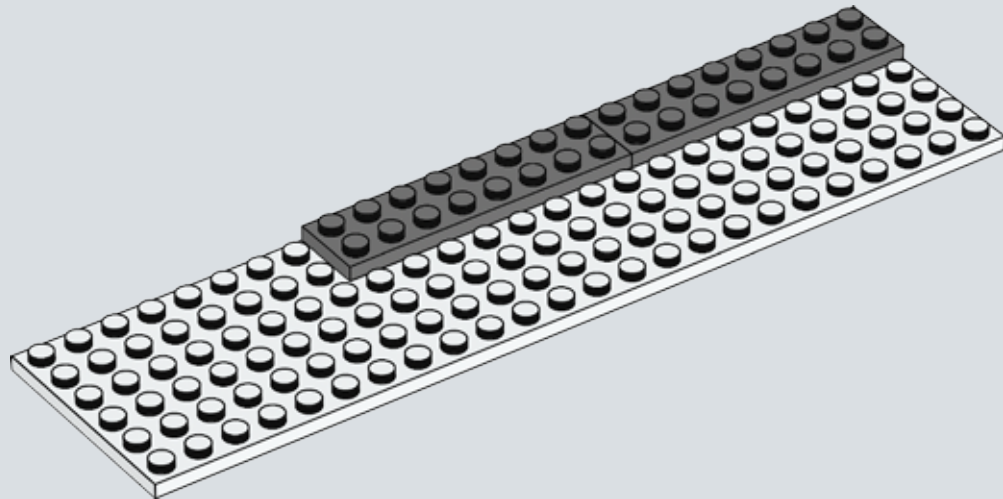

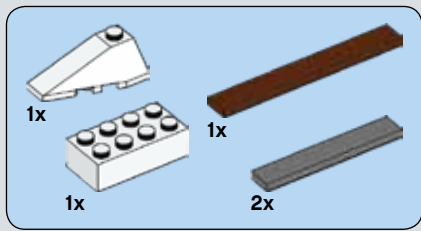

40

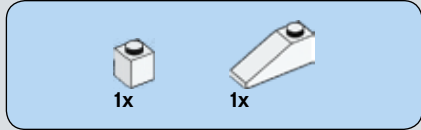
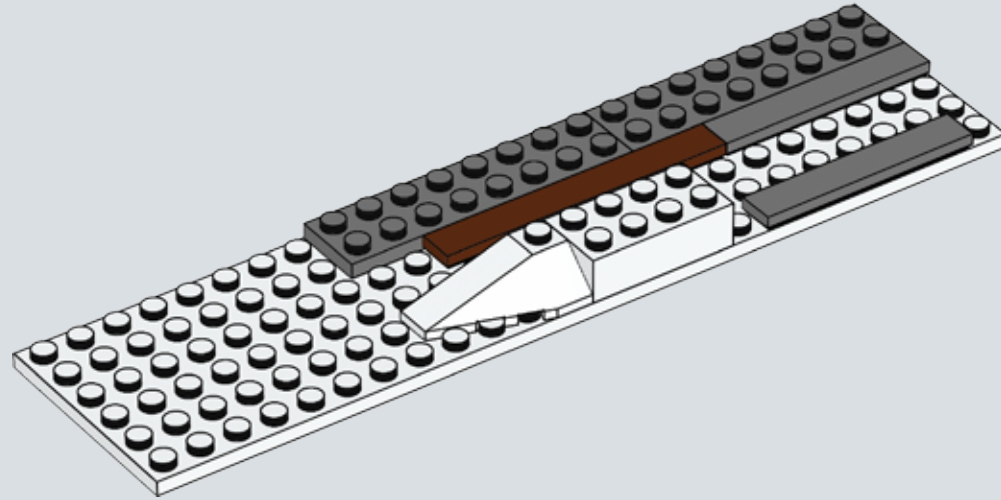

41

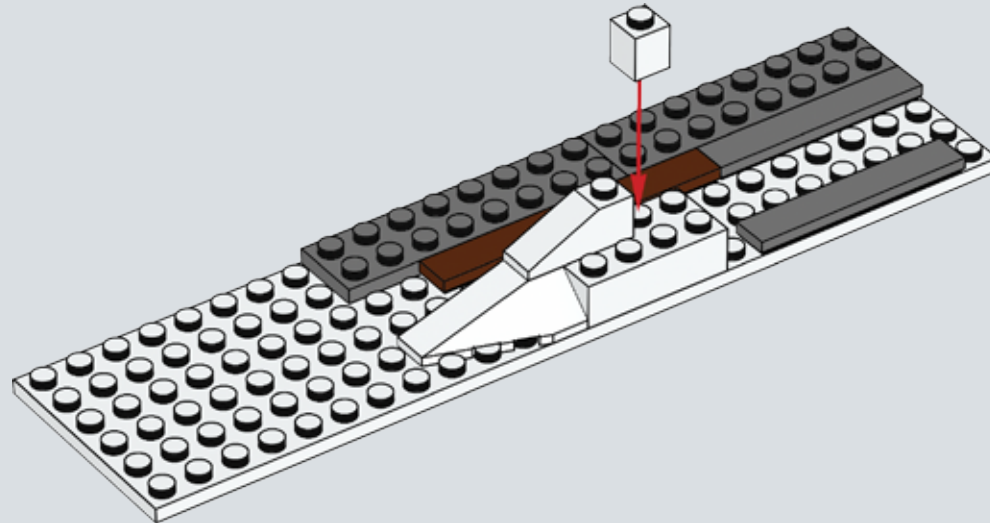



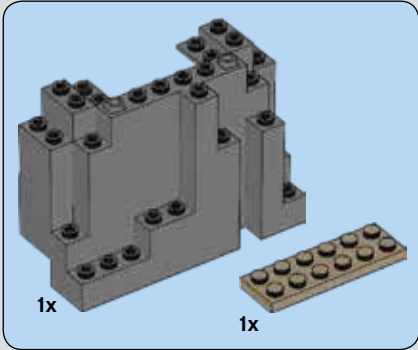
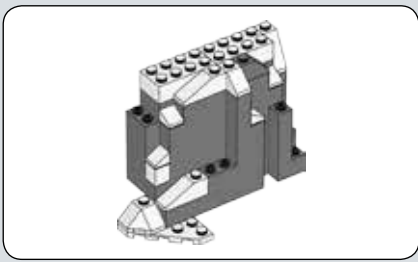

42

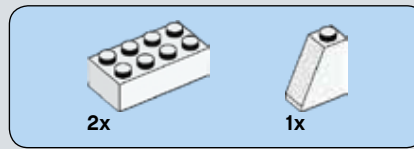
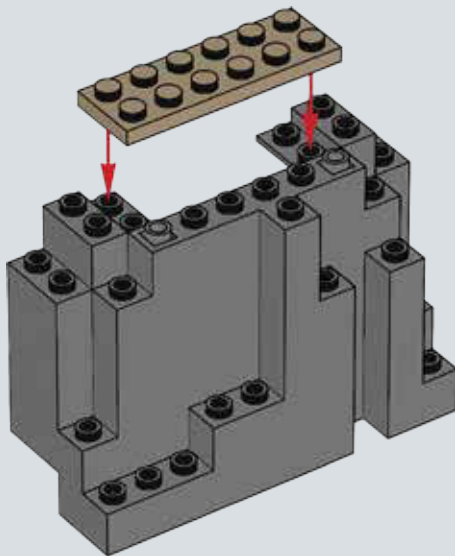

43

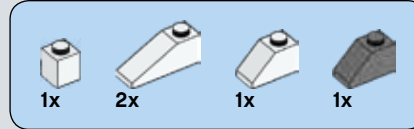
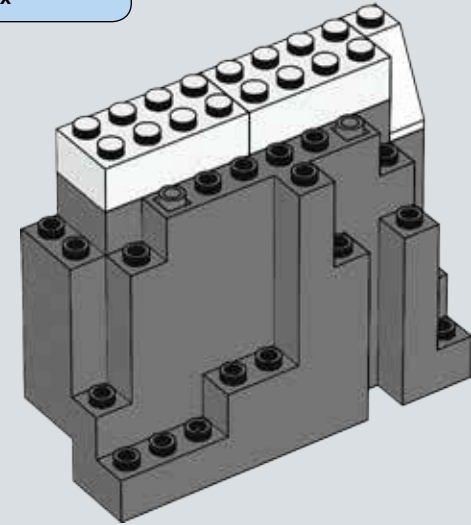

44

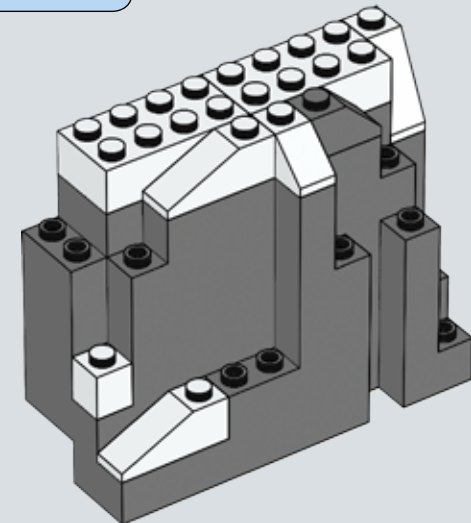



4x

45

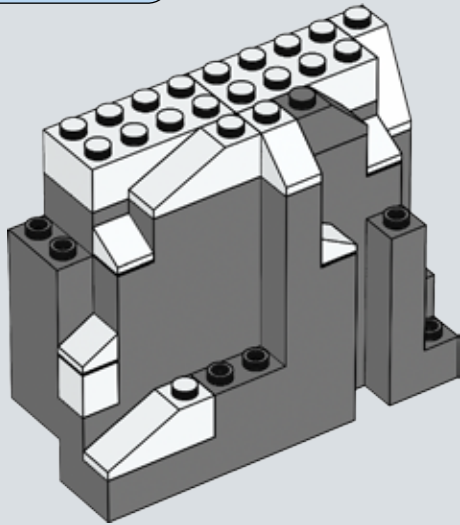

1x



1x

46

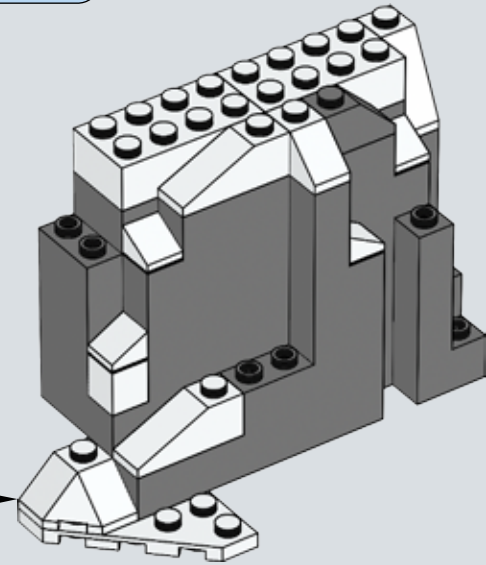
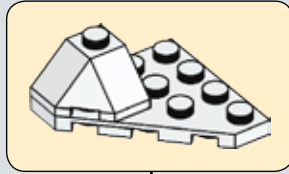

47

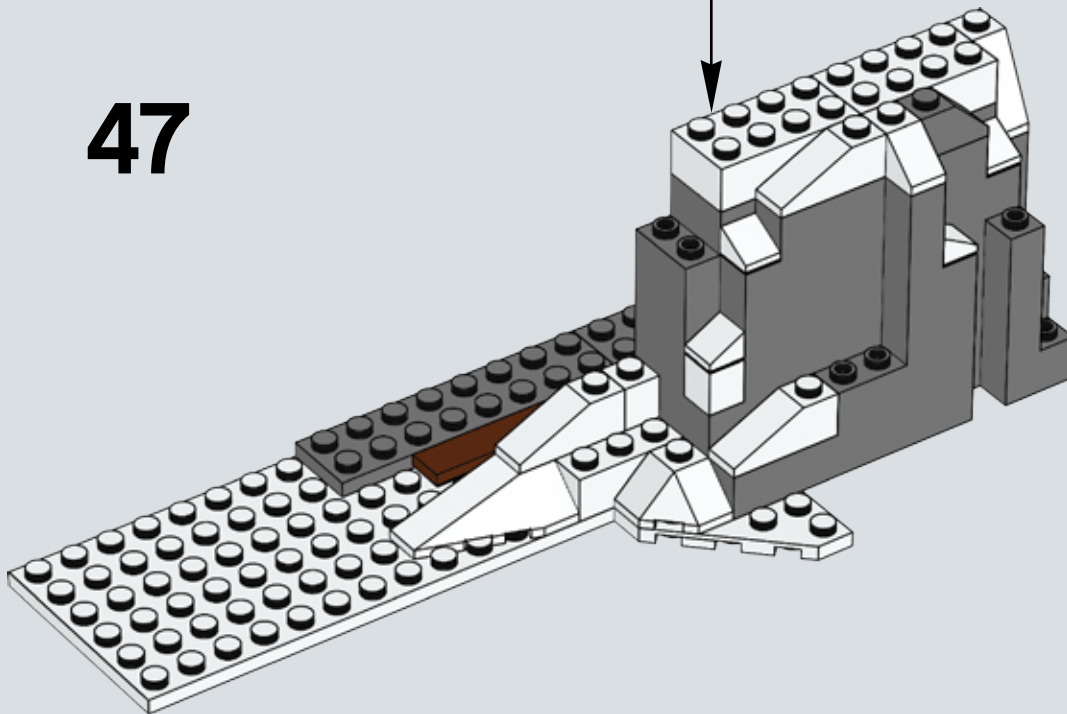

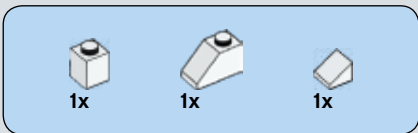

48

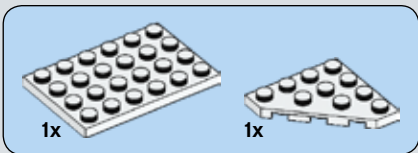
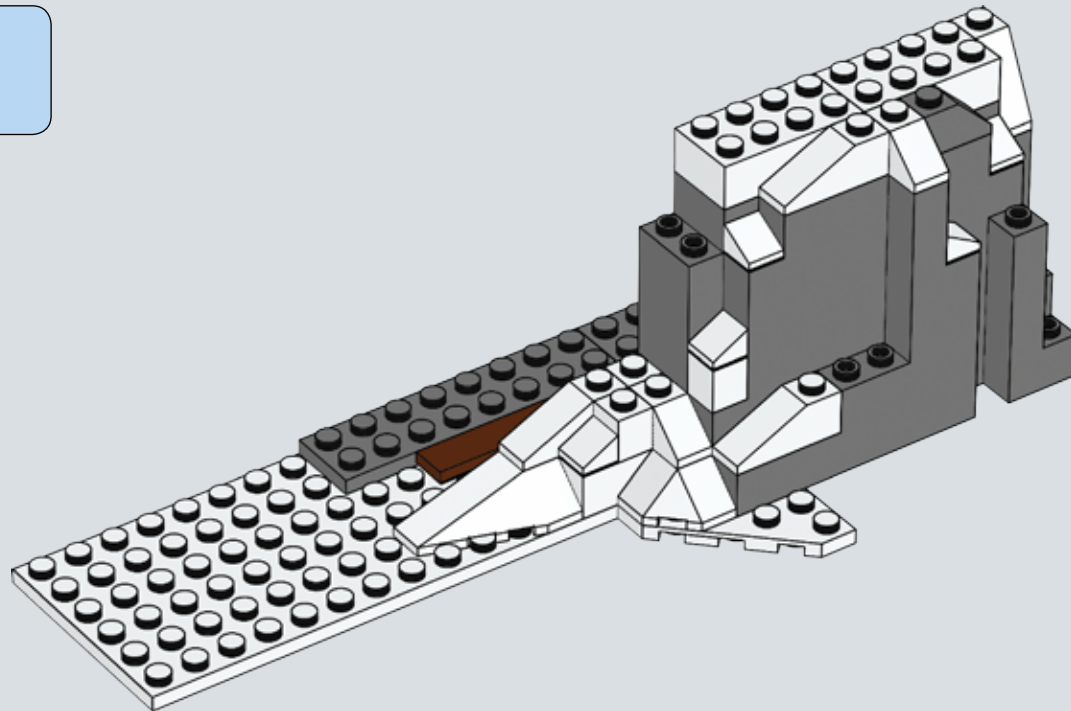

49

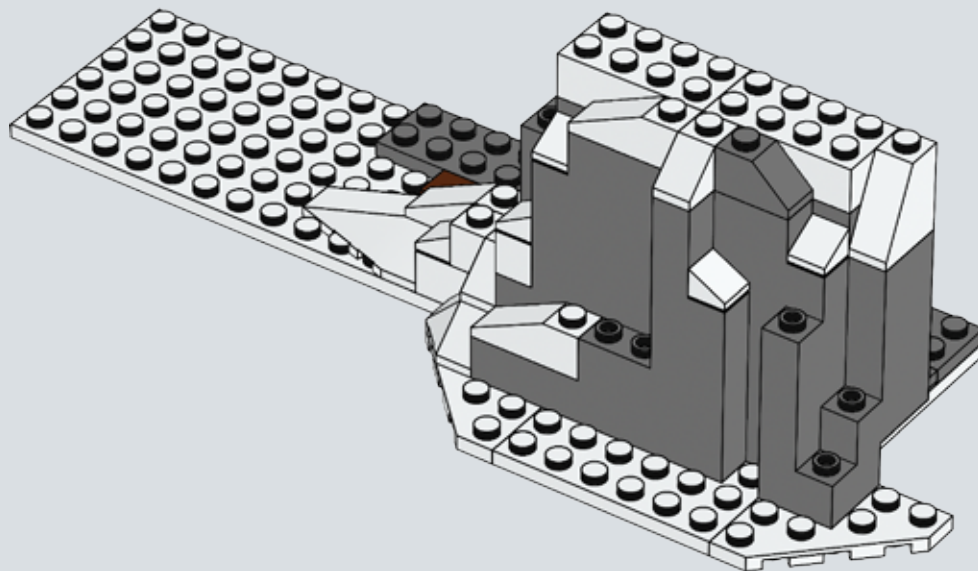

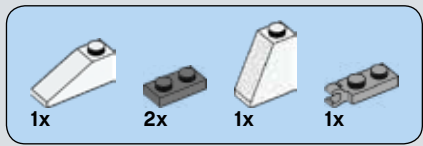

# 50

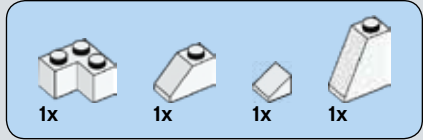
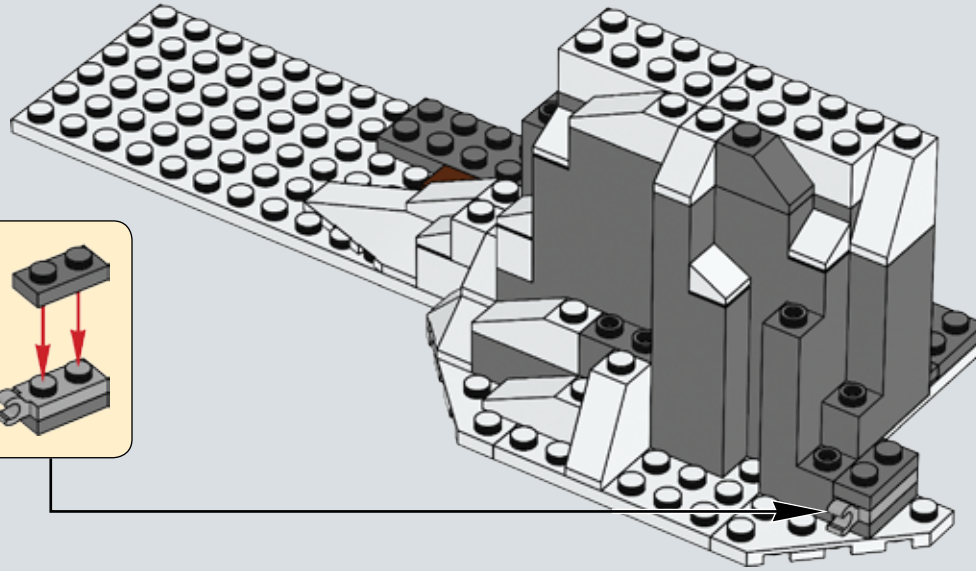
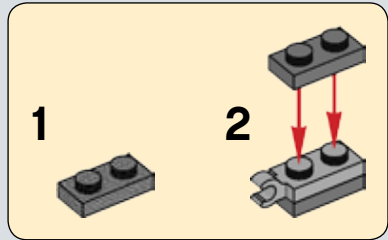

# 51

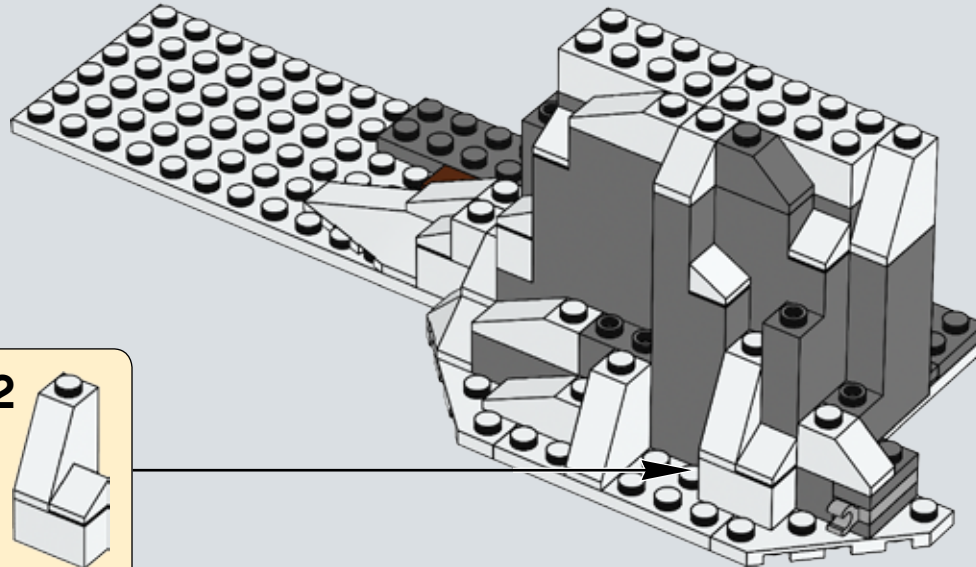
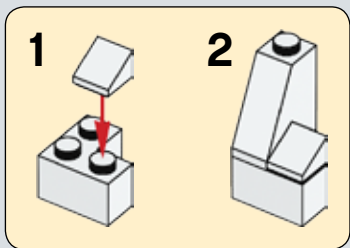



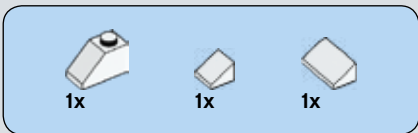

52

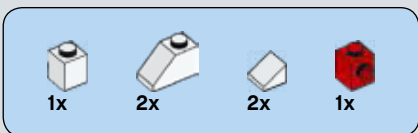
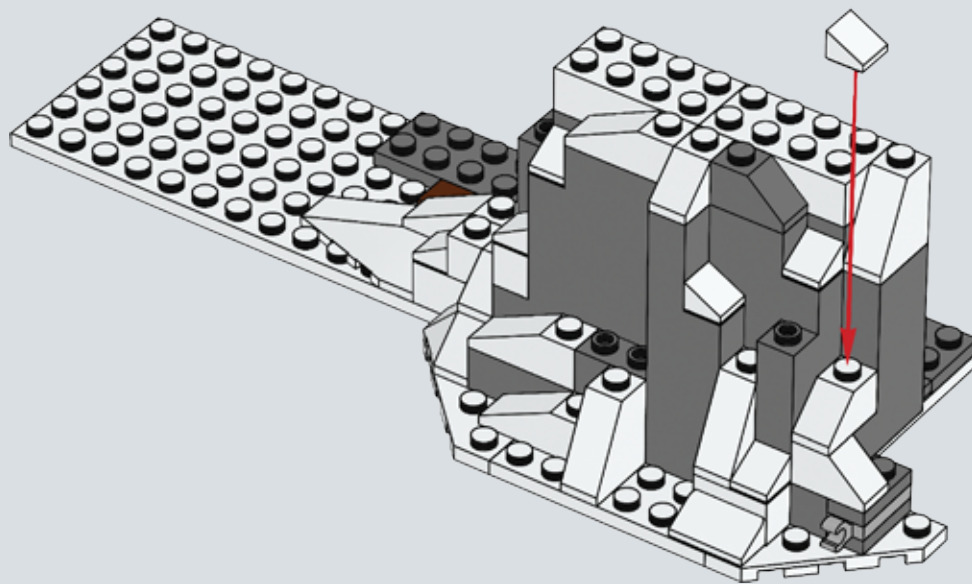

53

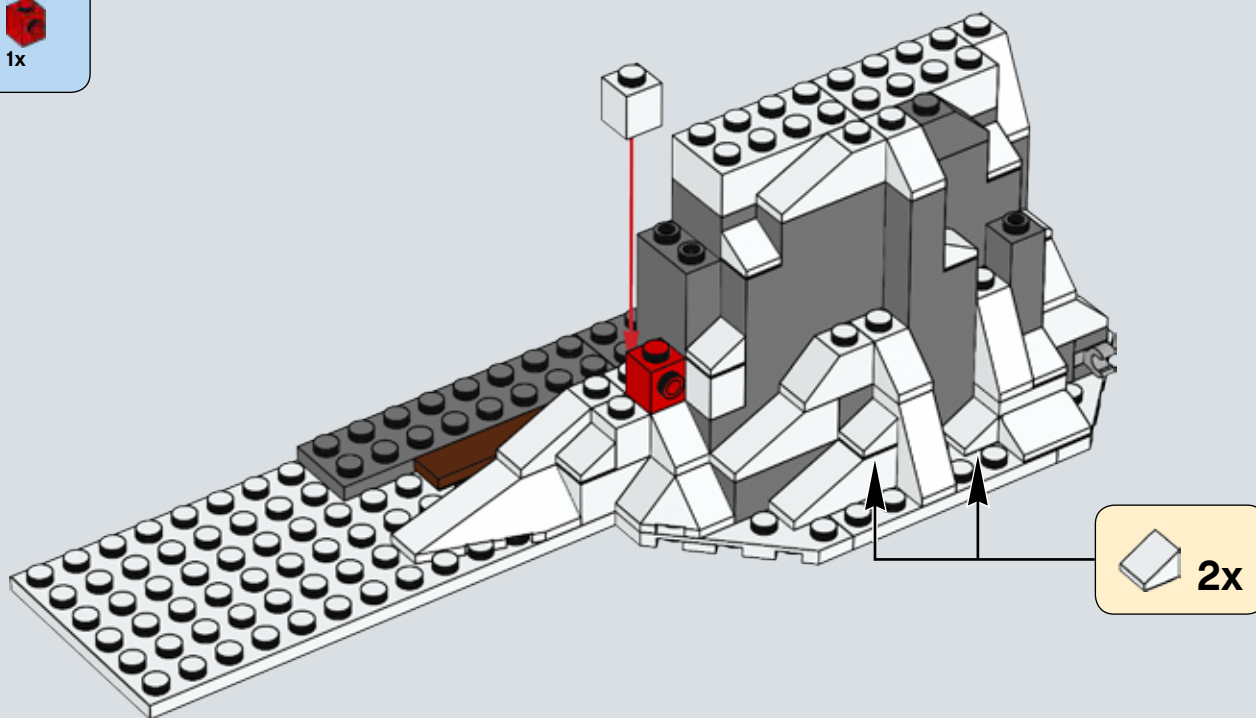

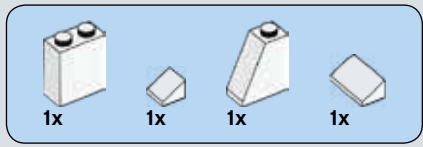

54

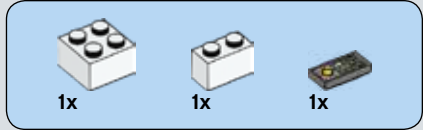
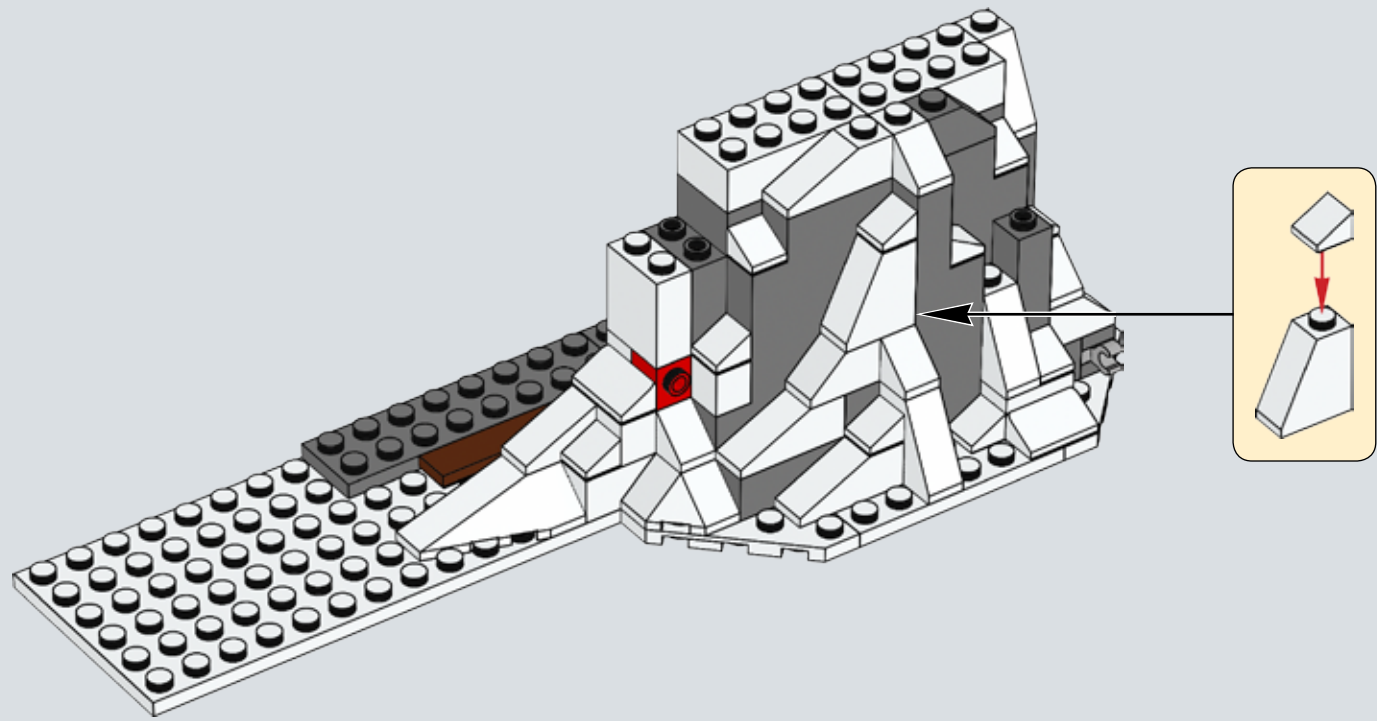

55

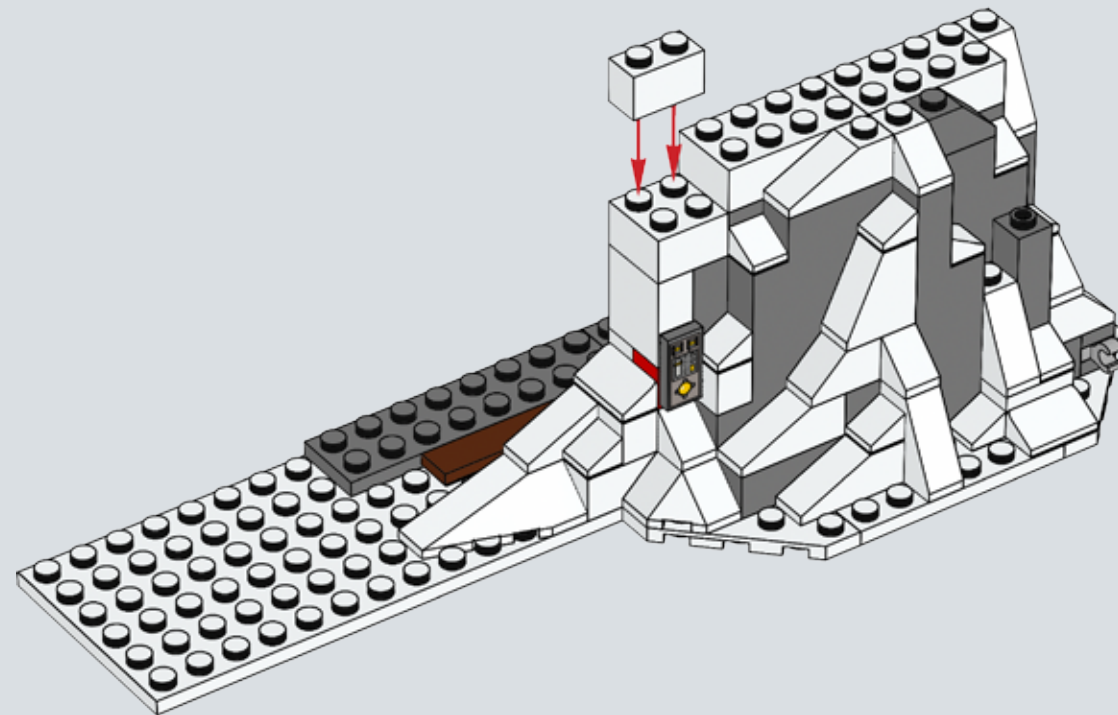

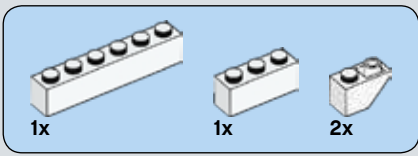

56

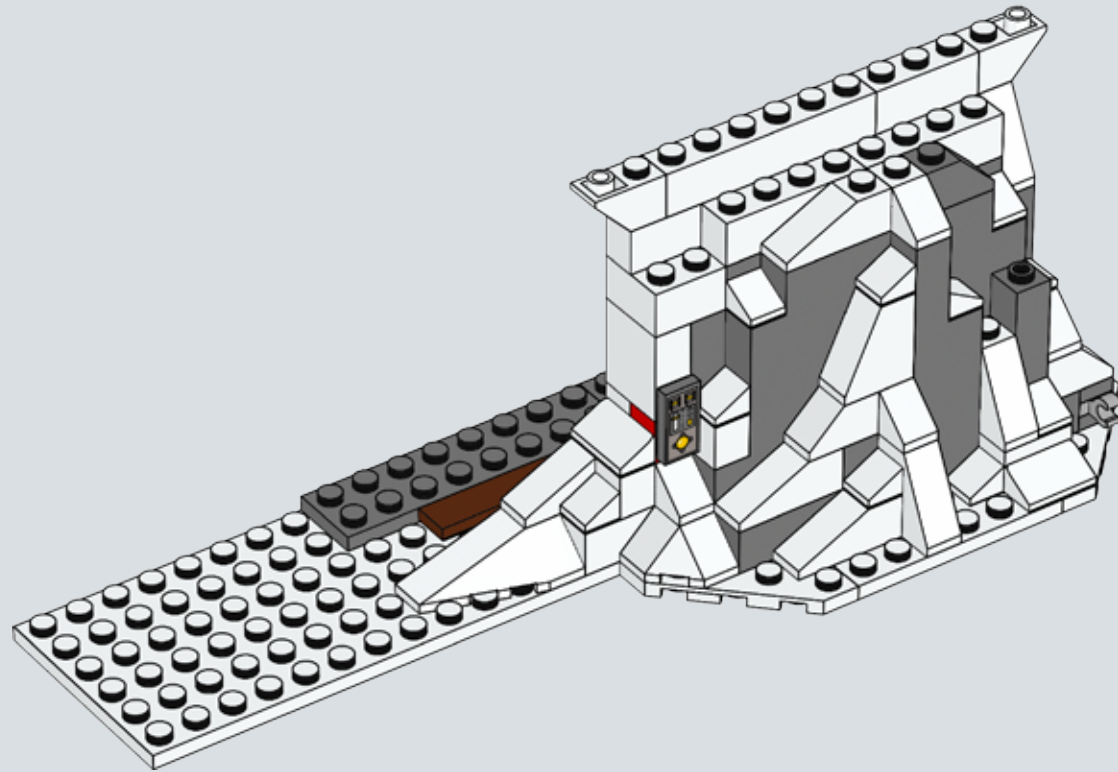

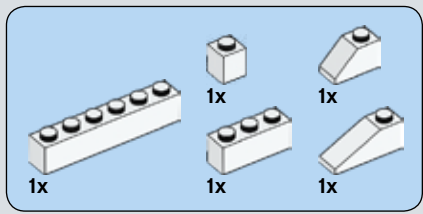

57

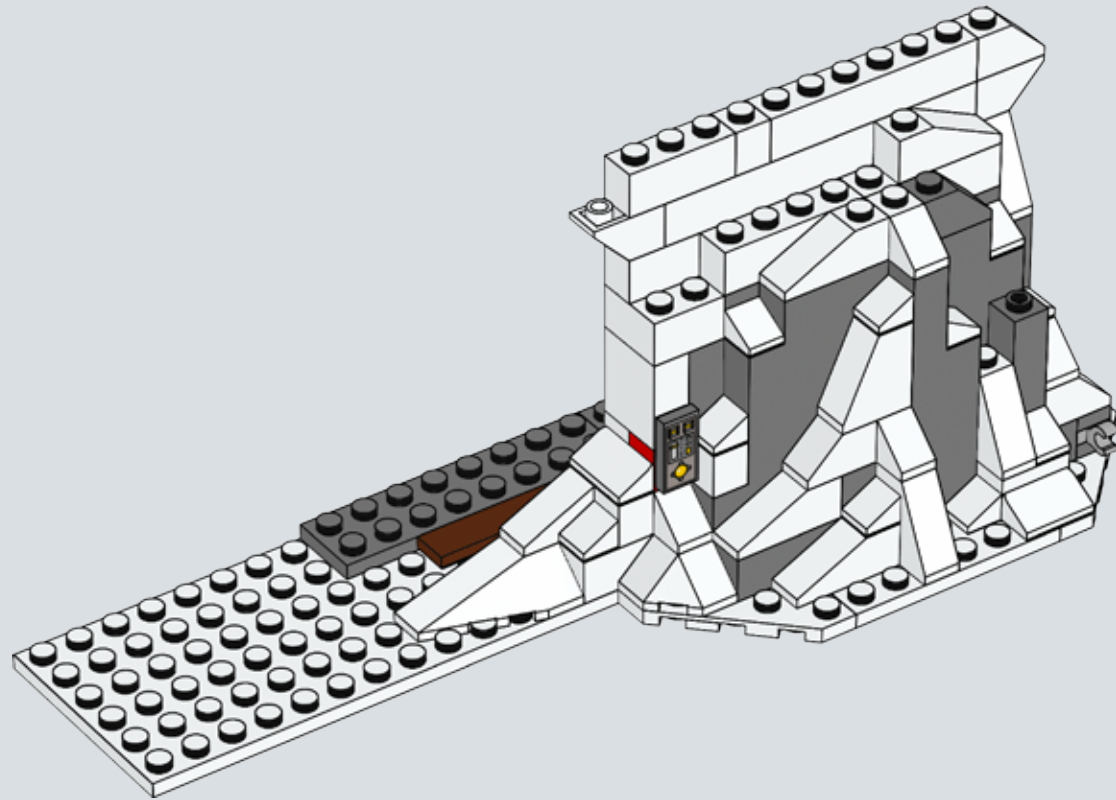



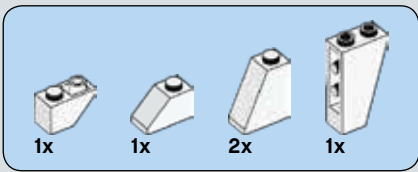

58

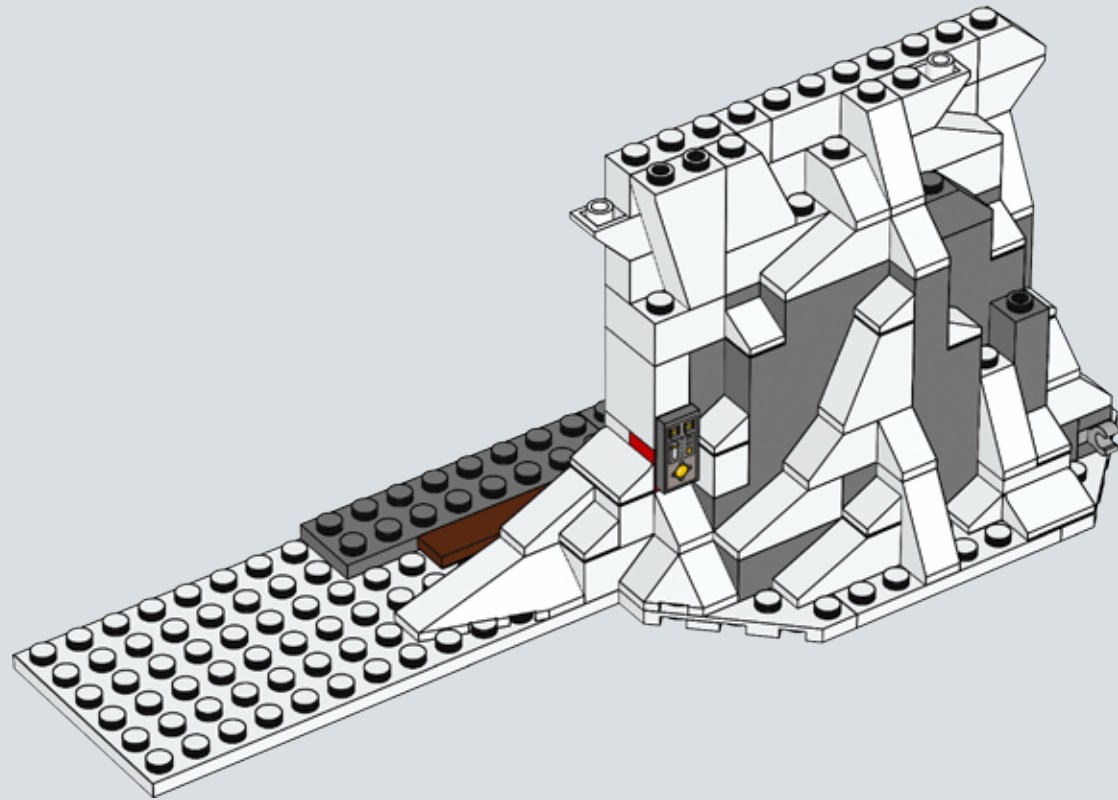

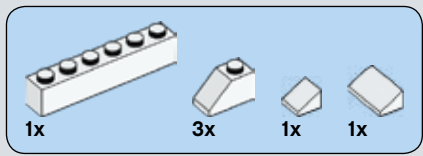

59

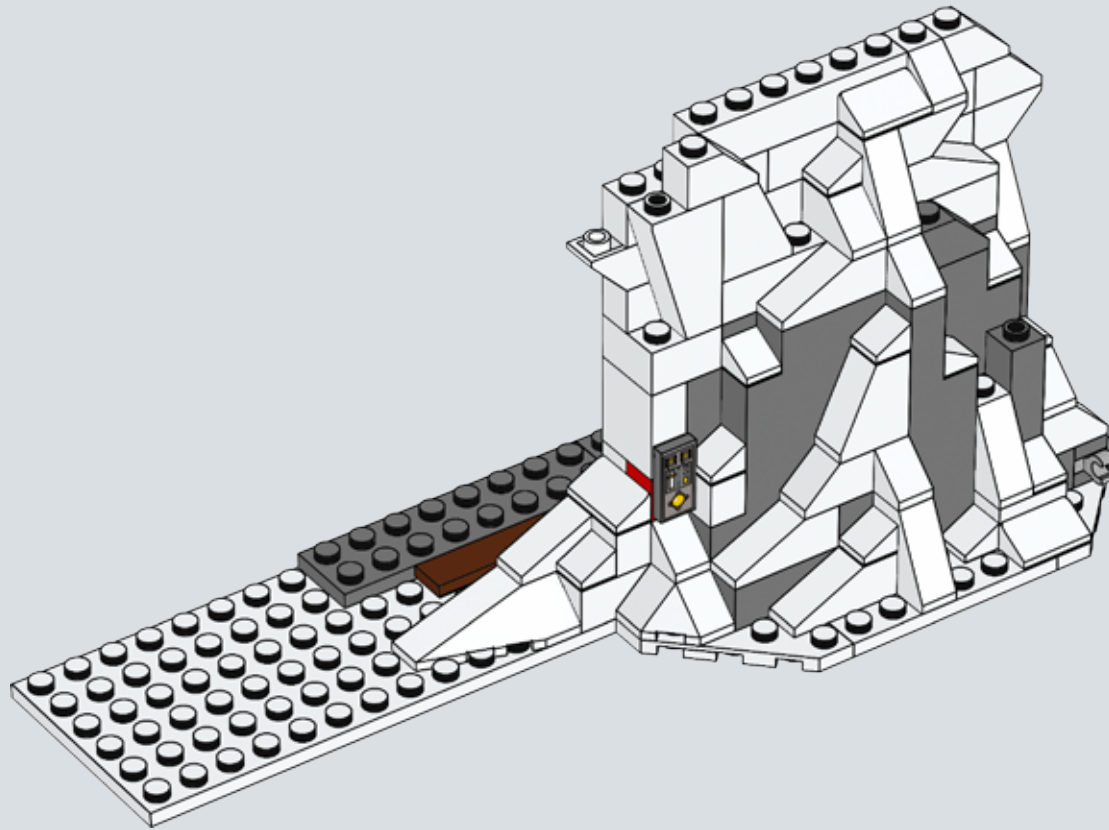

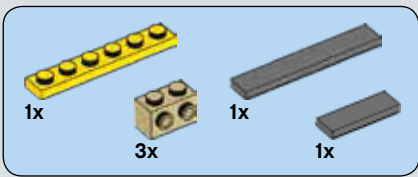

# 60

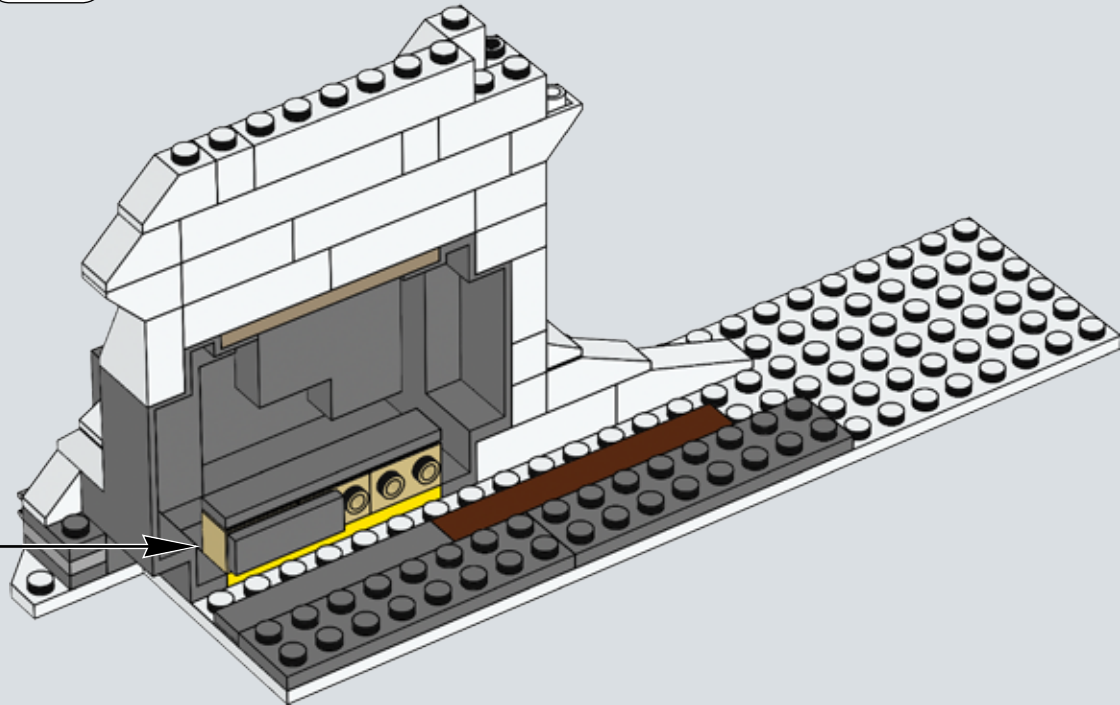
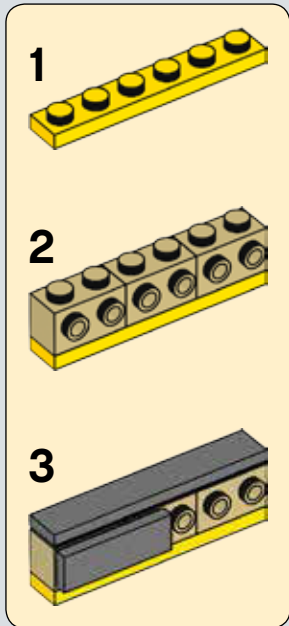
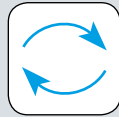

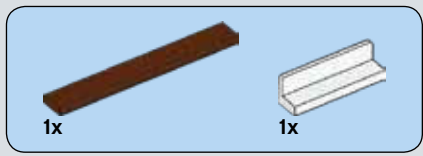

61

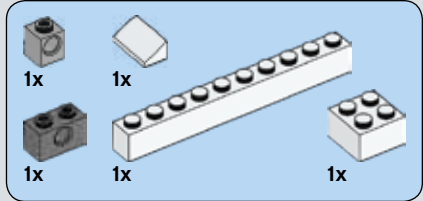
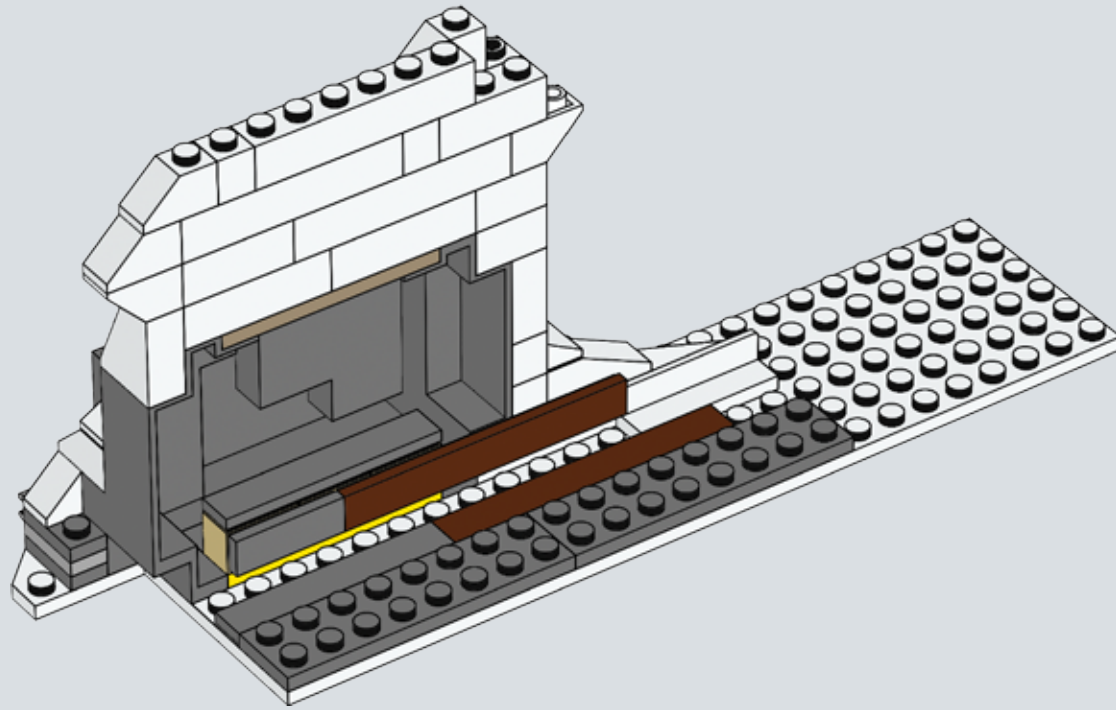

62

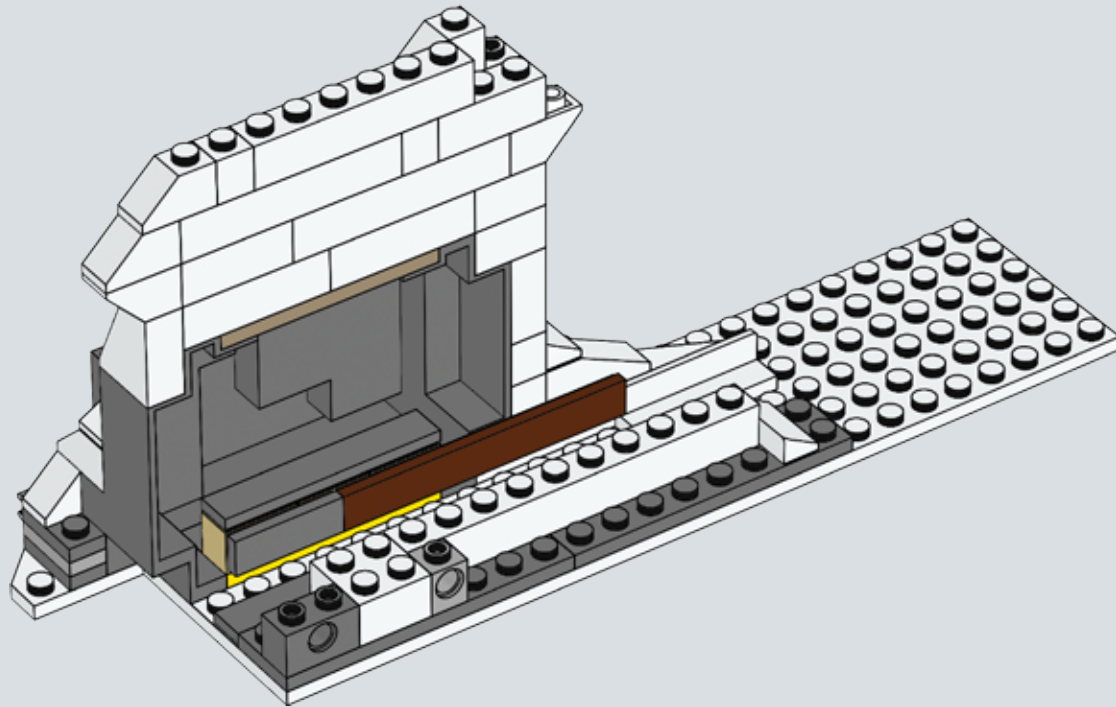





# 63

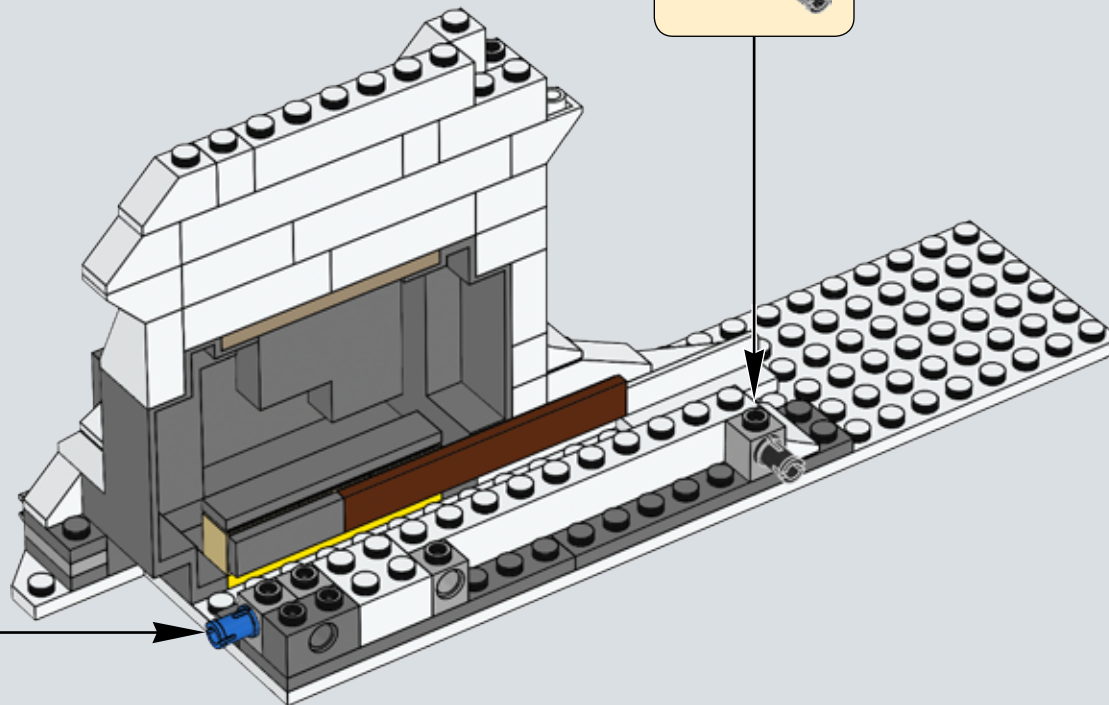
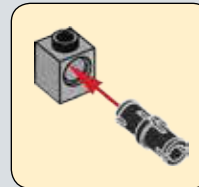
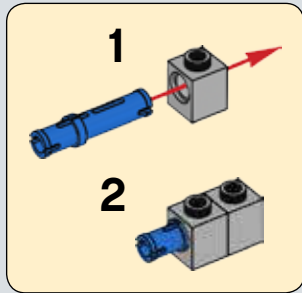

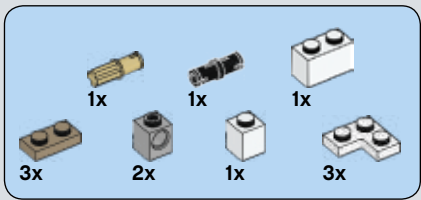

# 64

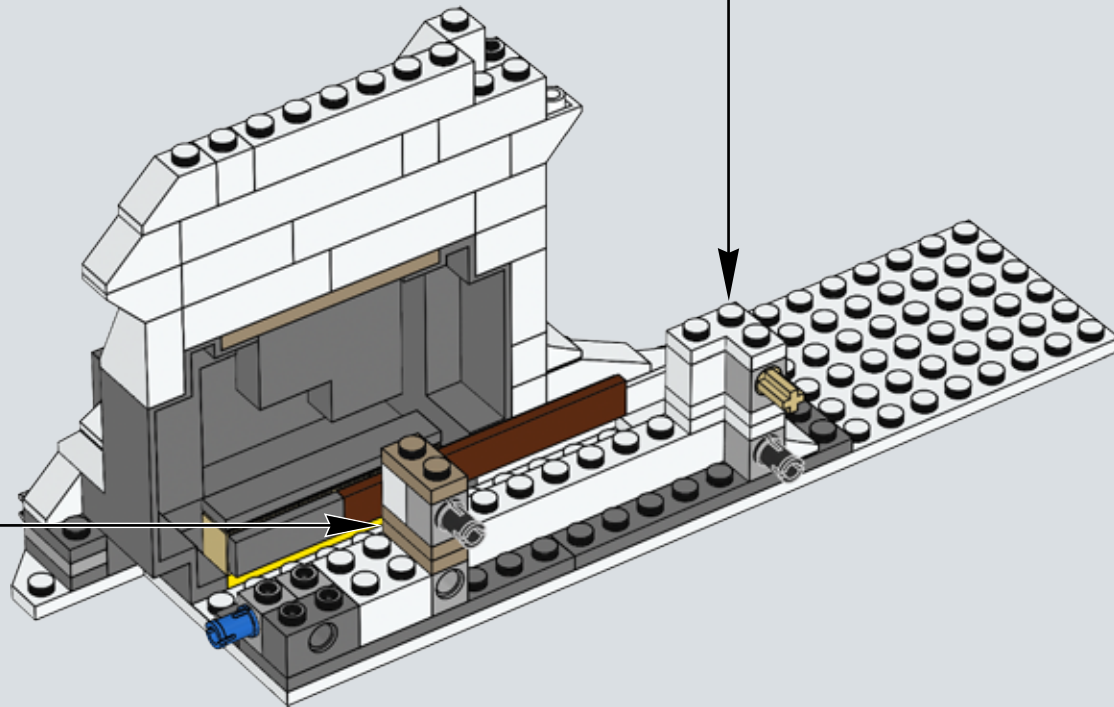
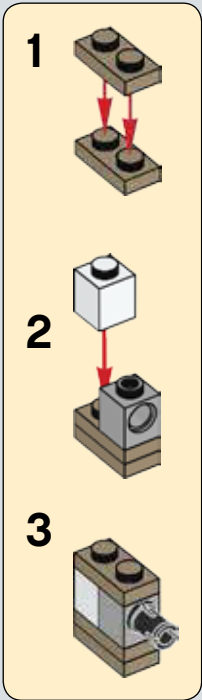
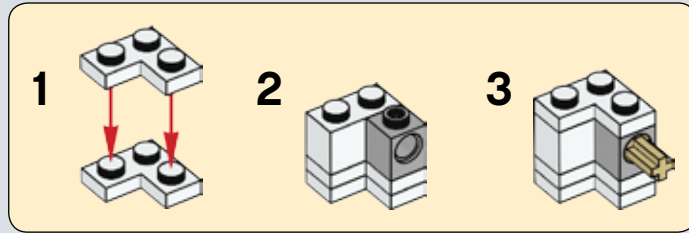

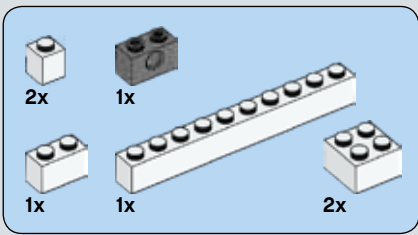

# 65

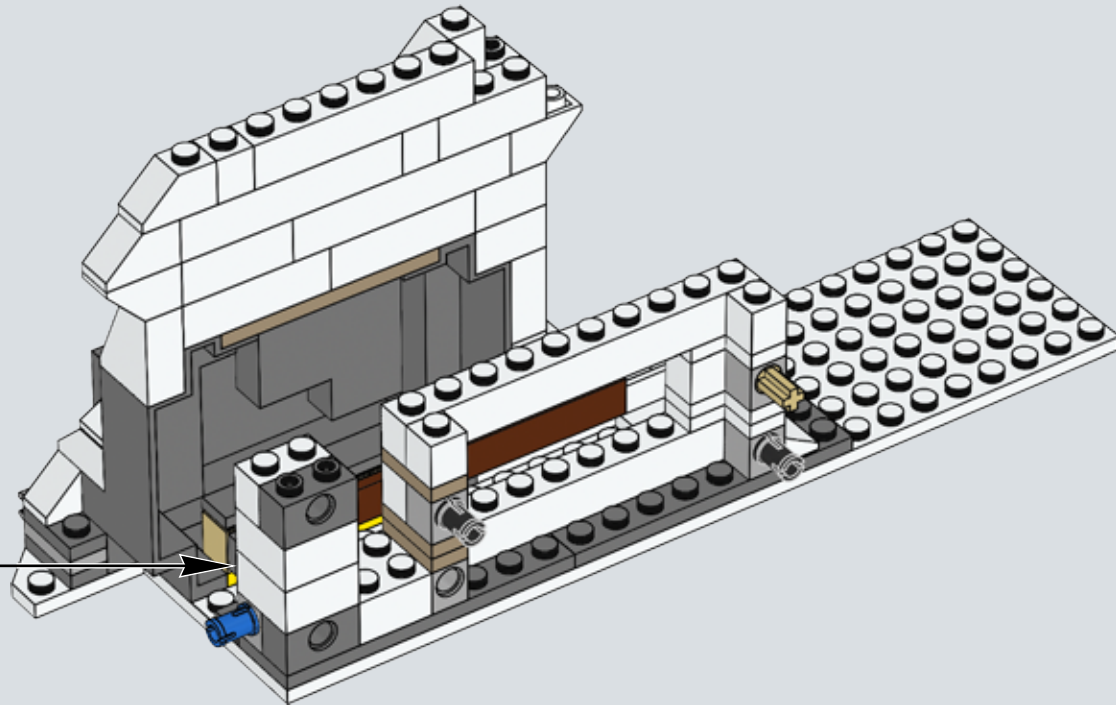
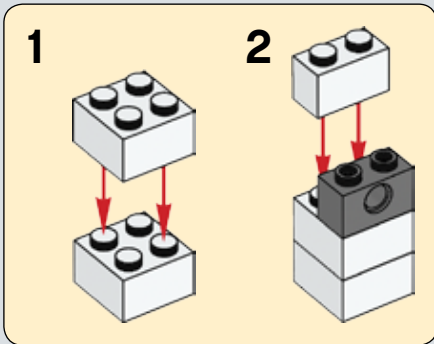

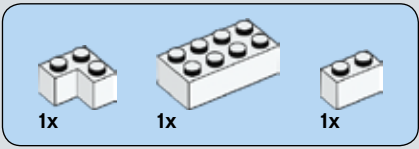

# 66

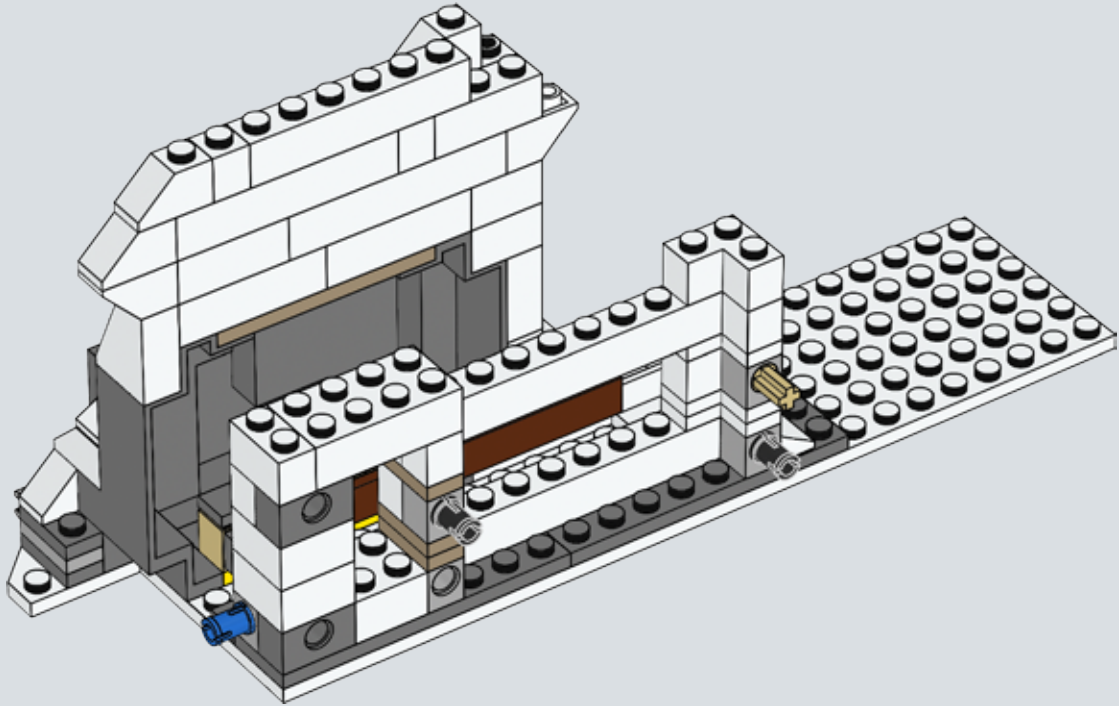

# 67

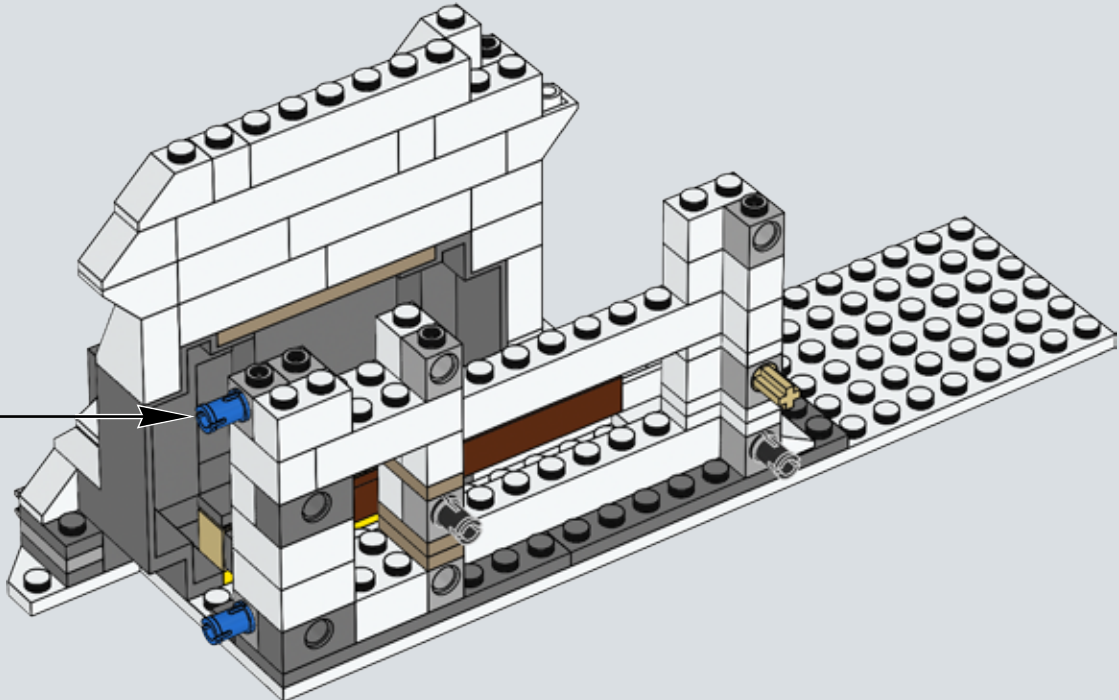
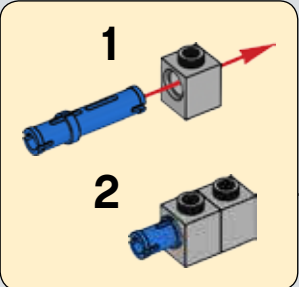



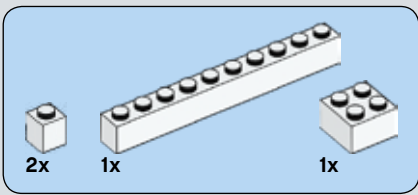

68

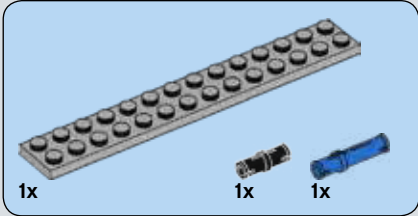
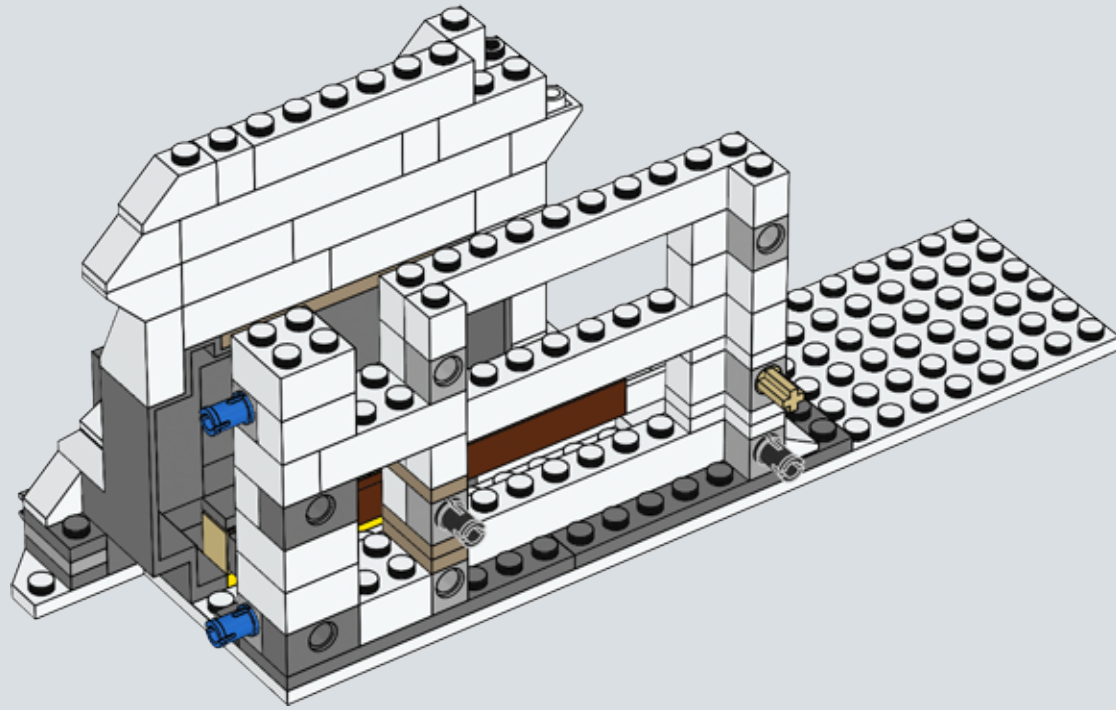

69

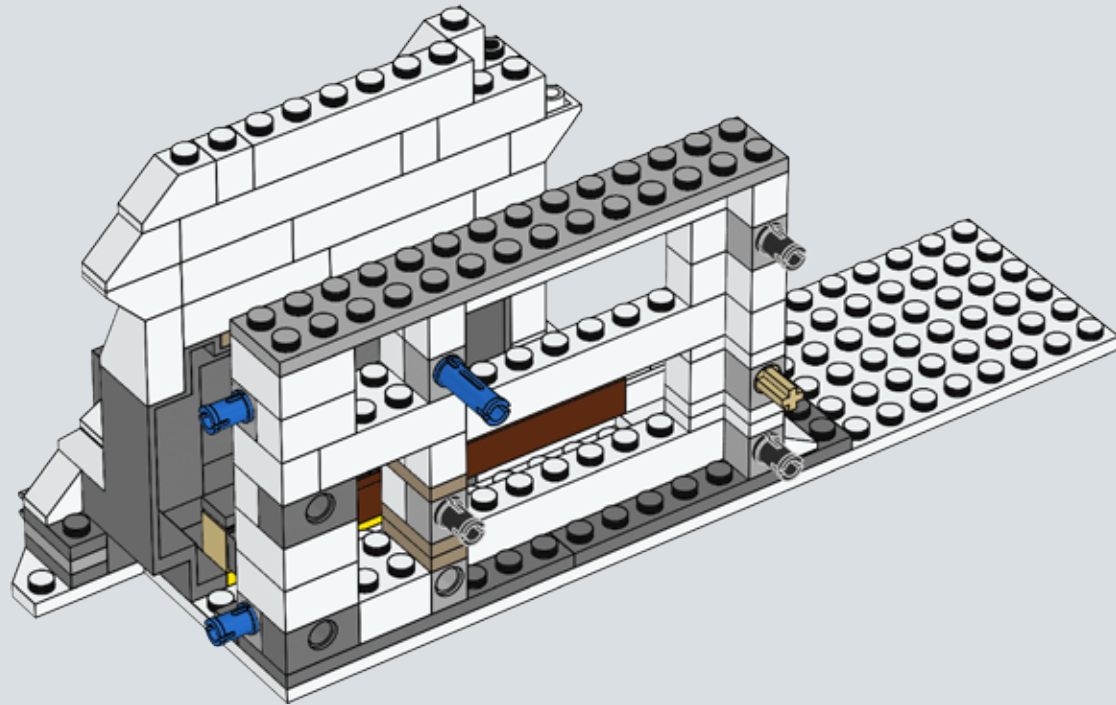

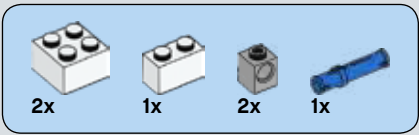

# 70

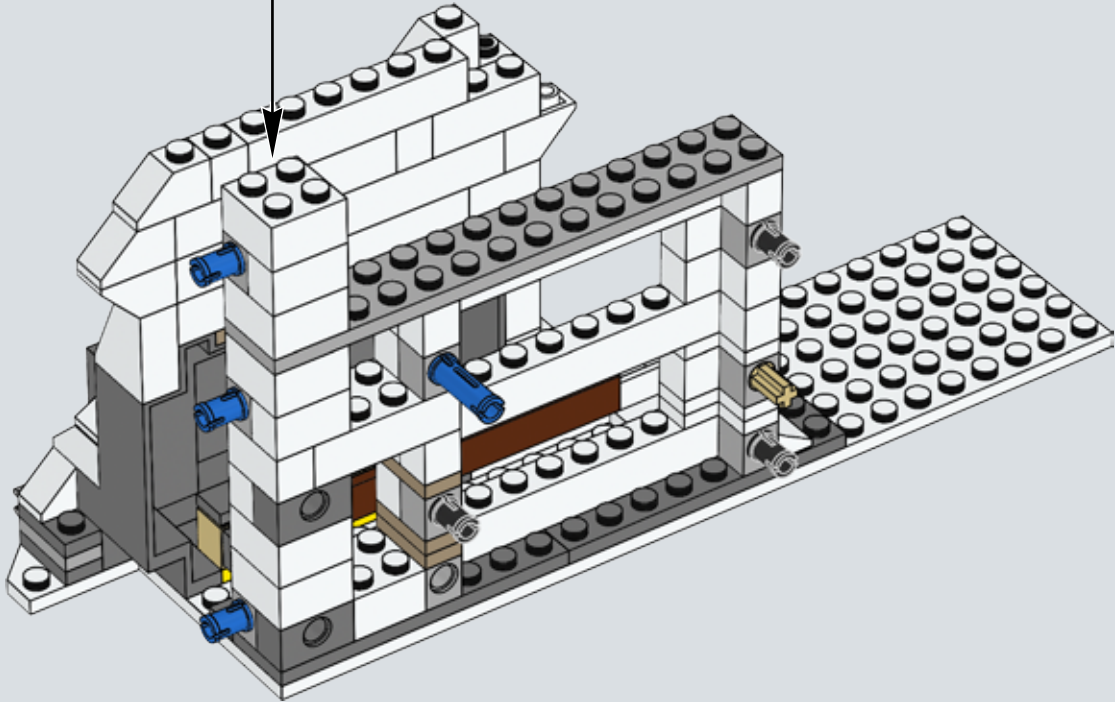
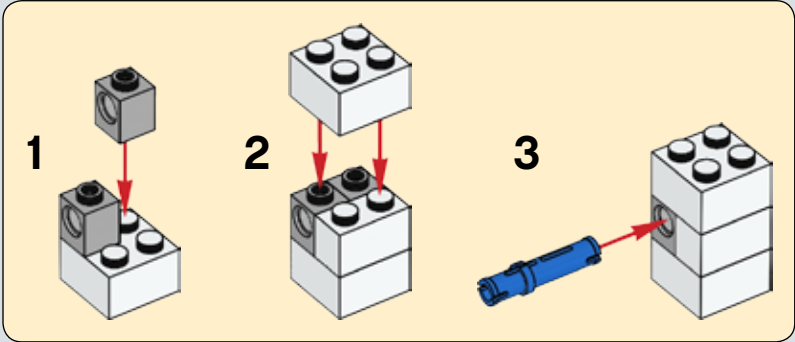

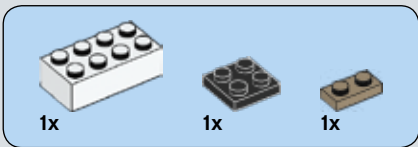
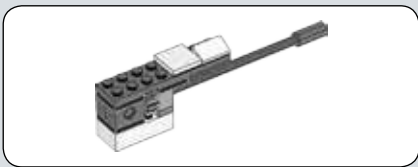

71

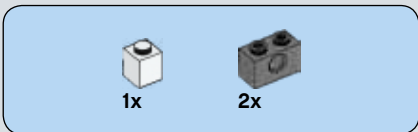
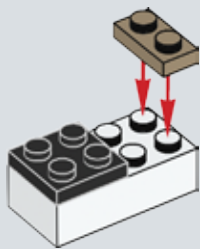

72

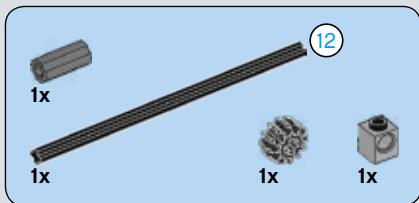
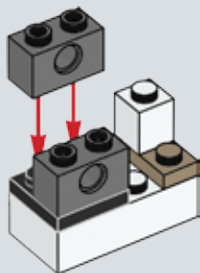

73

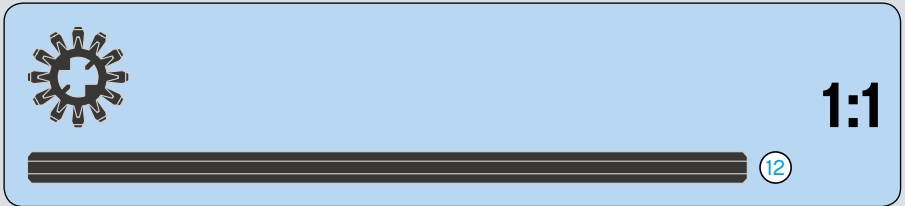
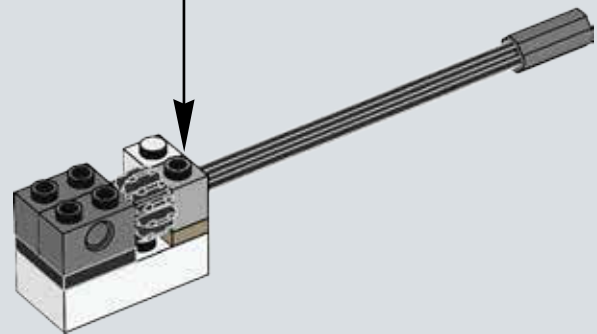
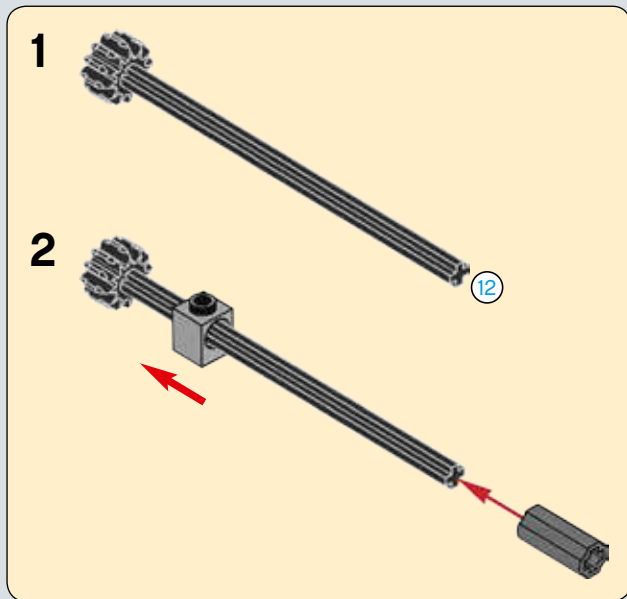



74

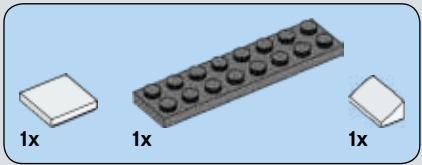
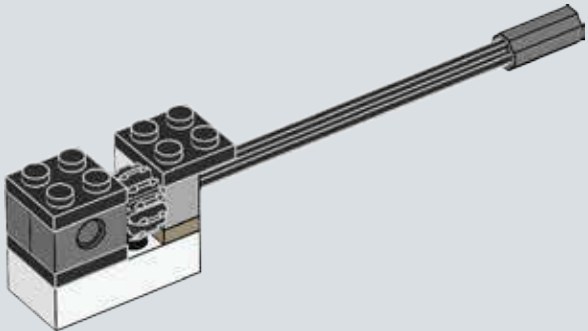

75

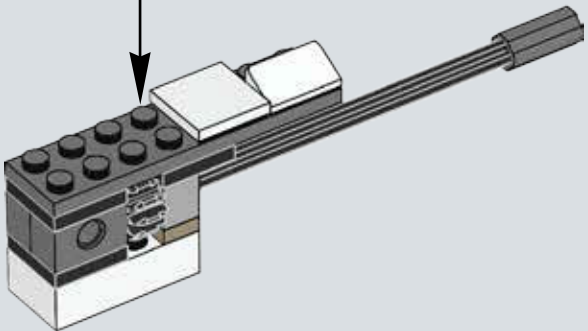
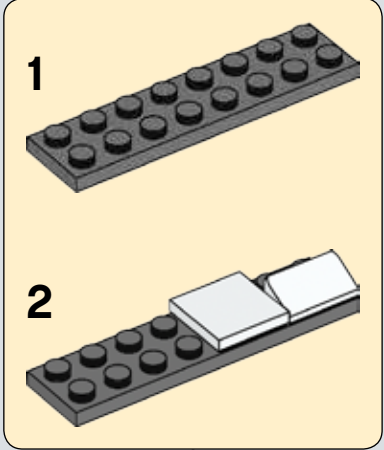



# 76

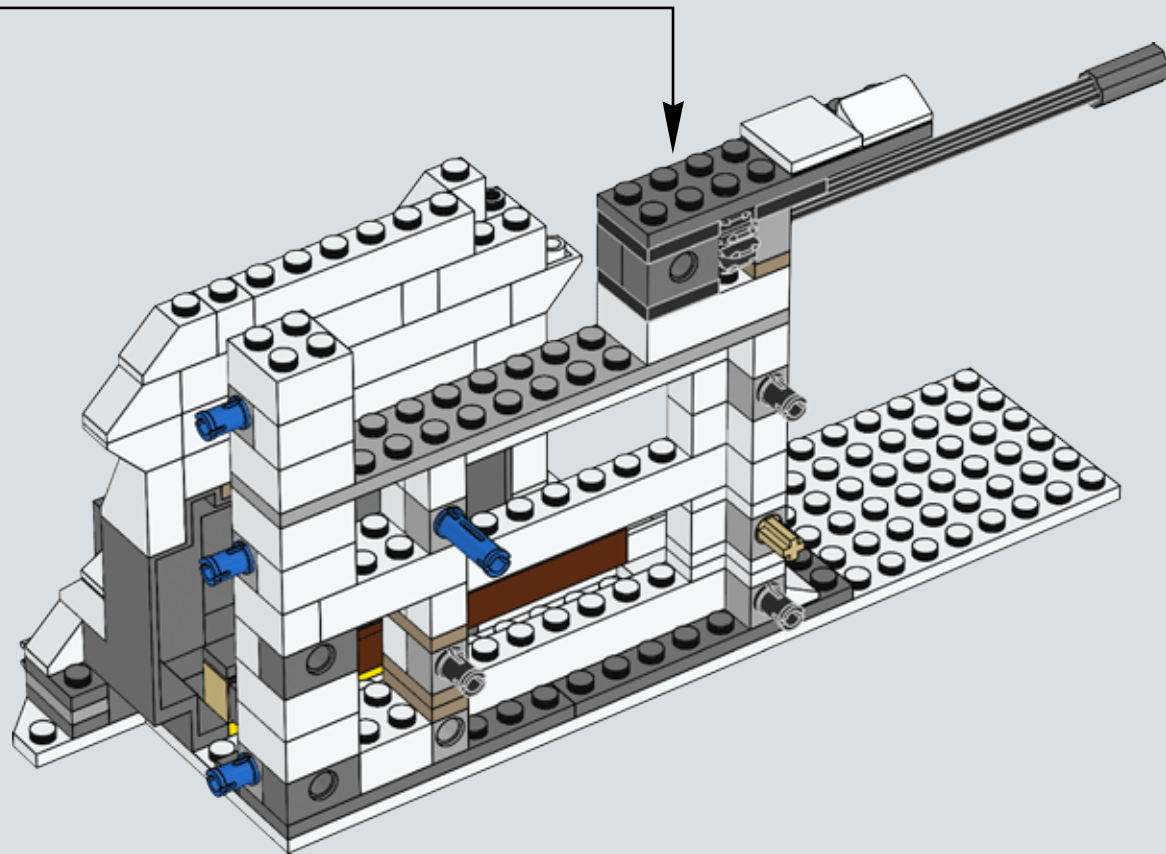

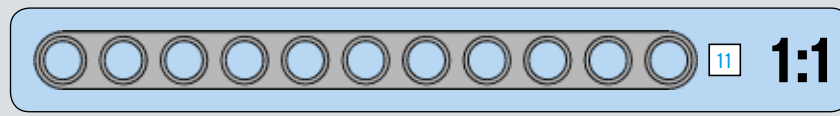
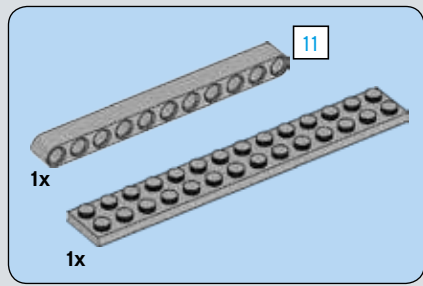

77

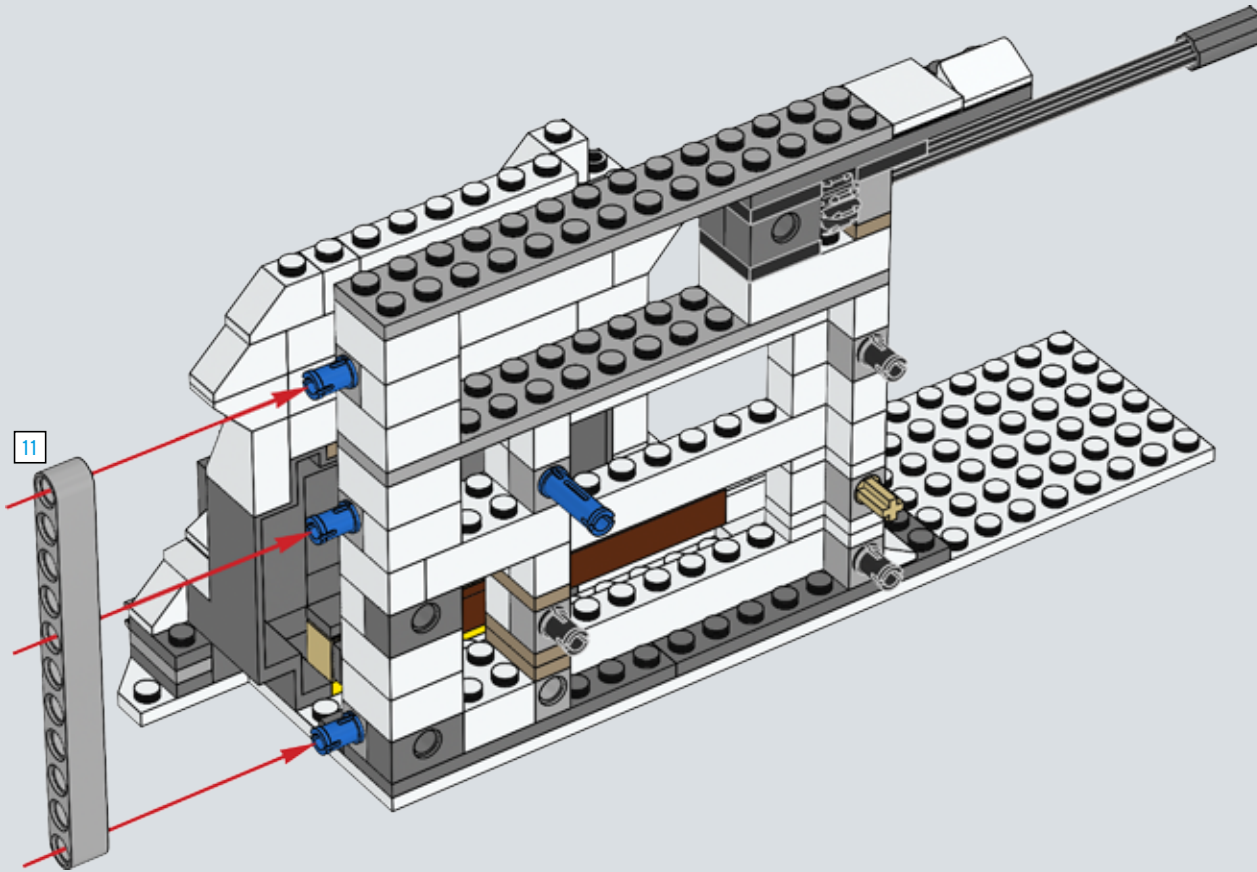

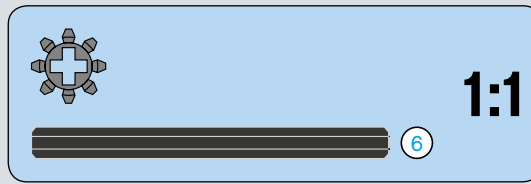
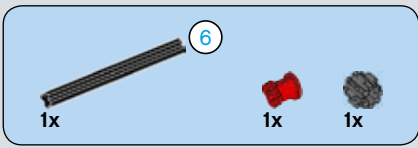

78

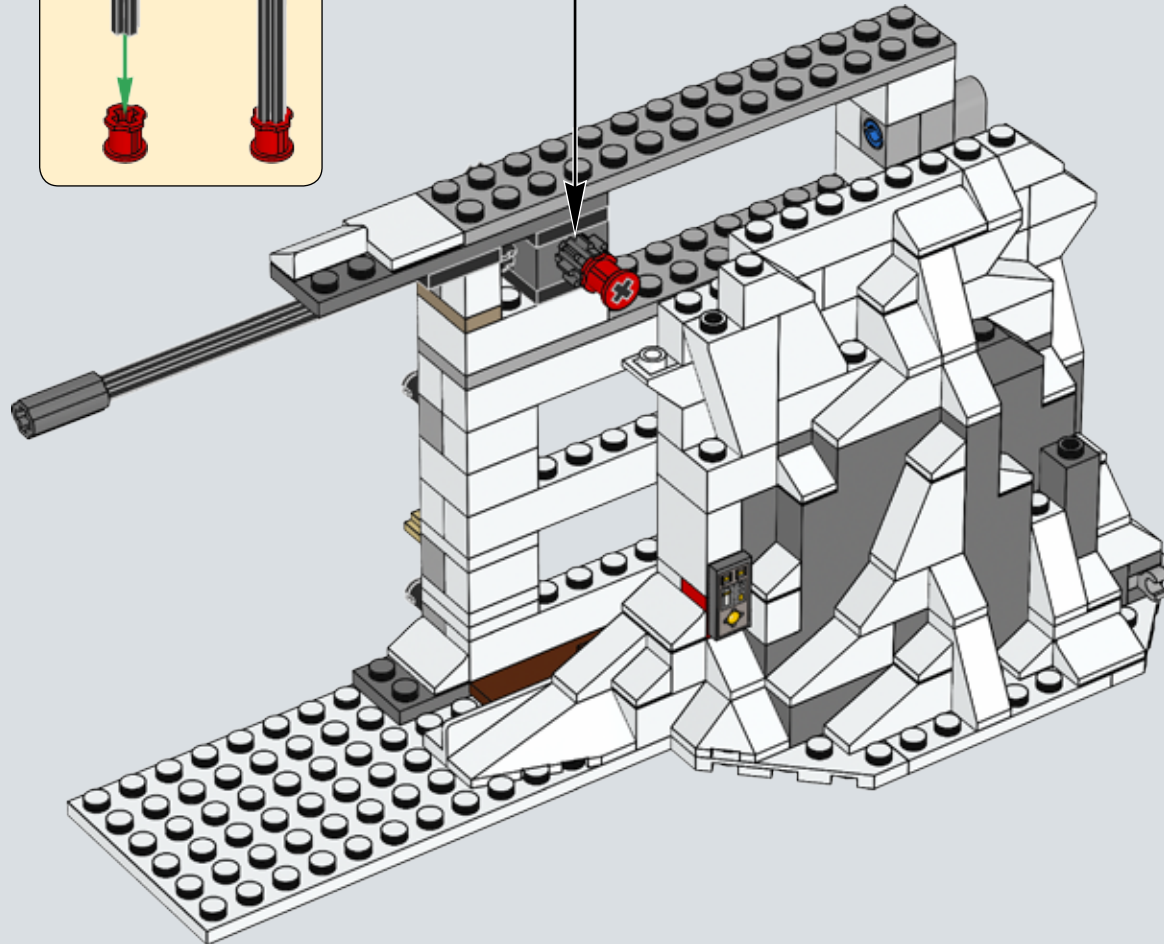
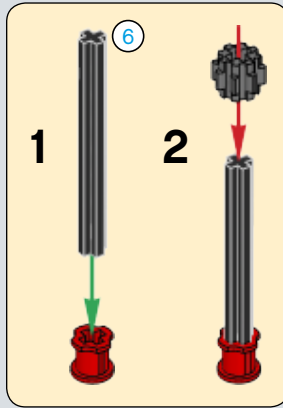

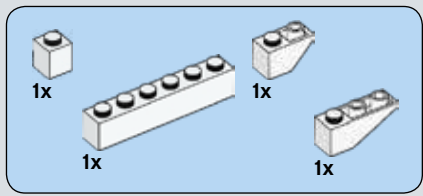

# 79

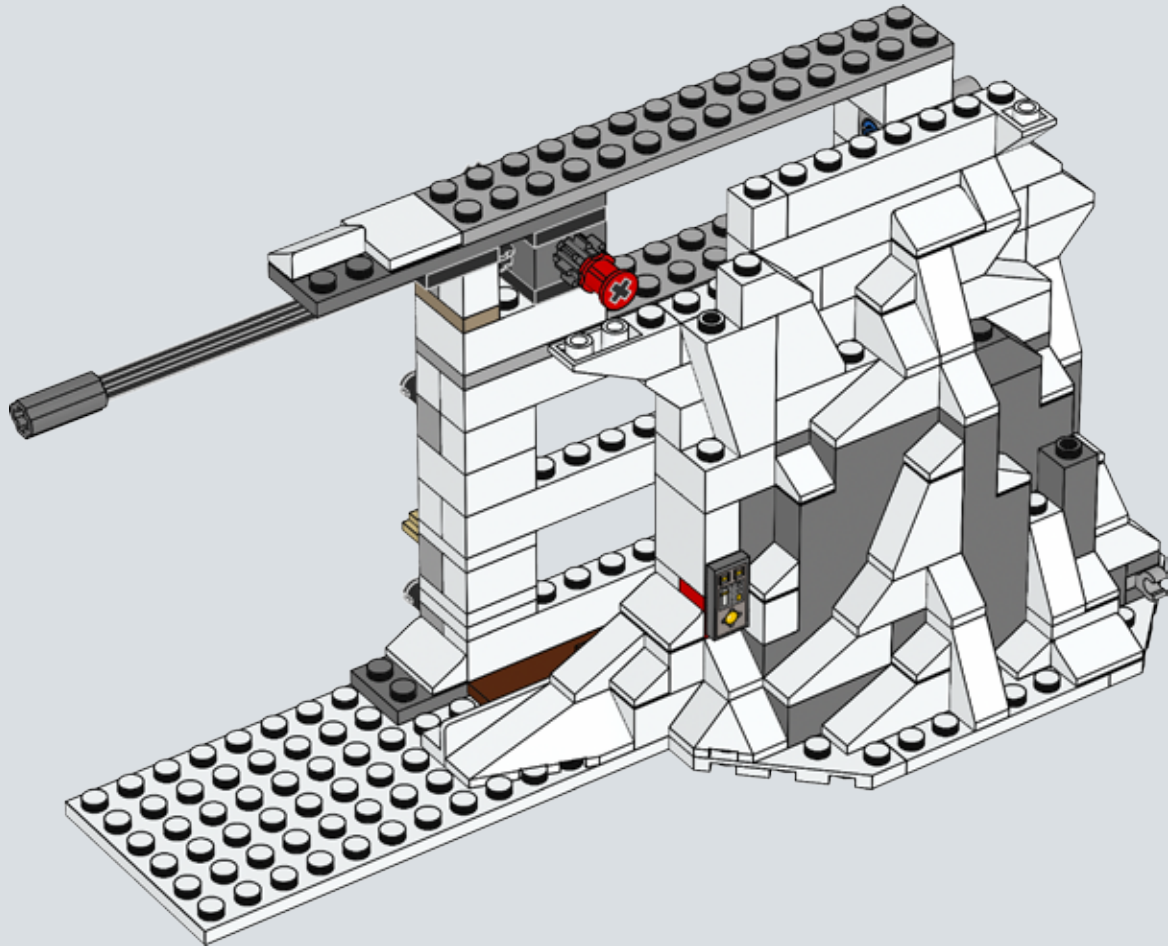



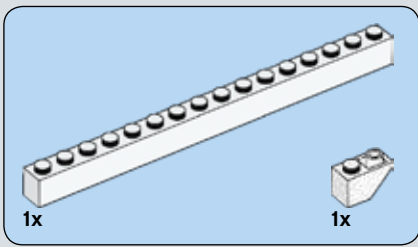

80

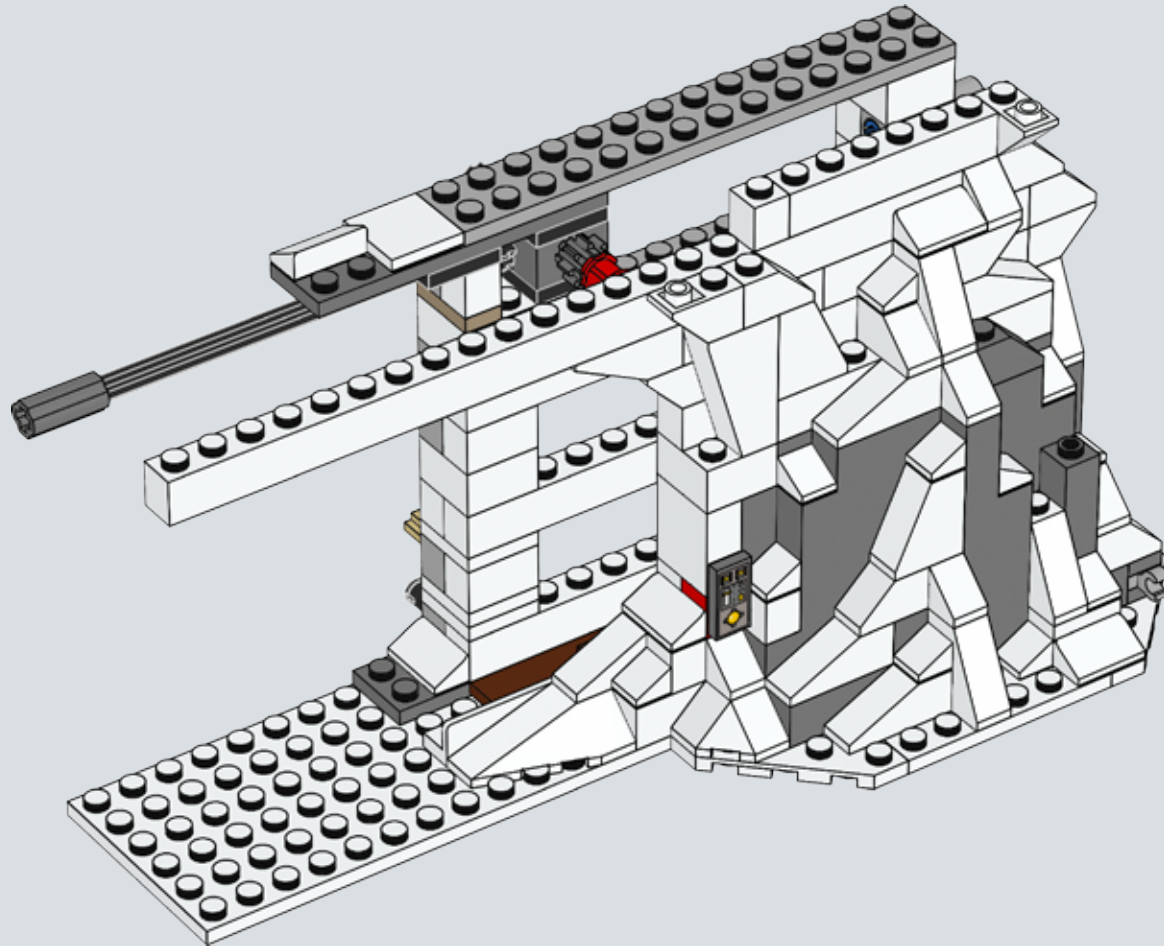

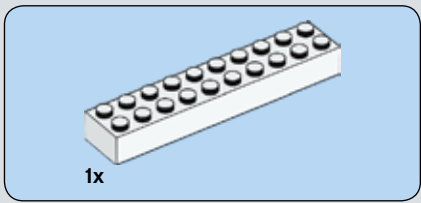

81

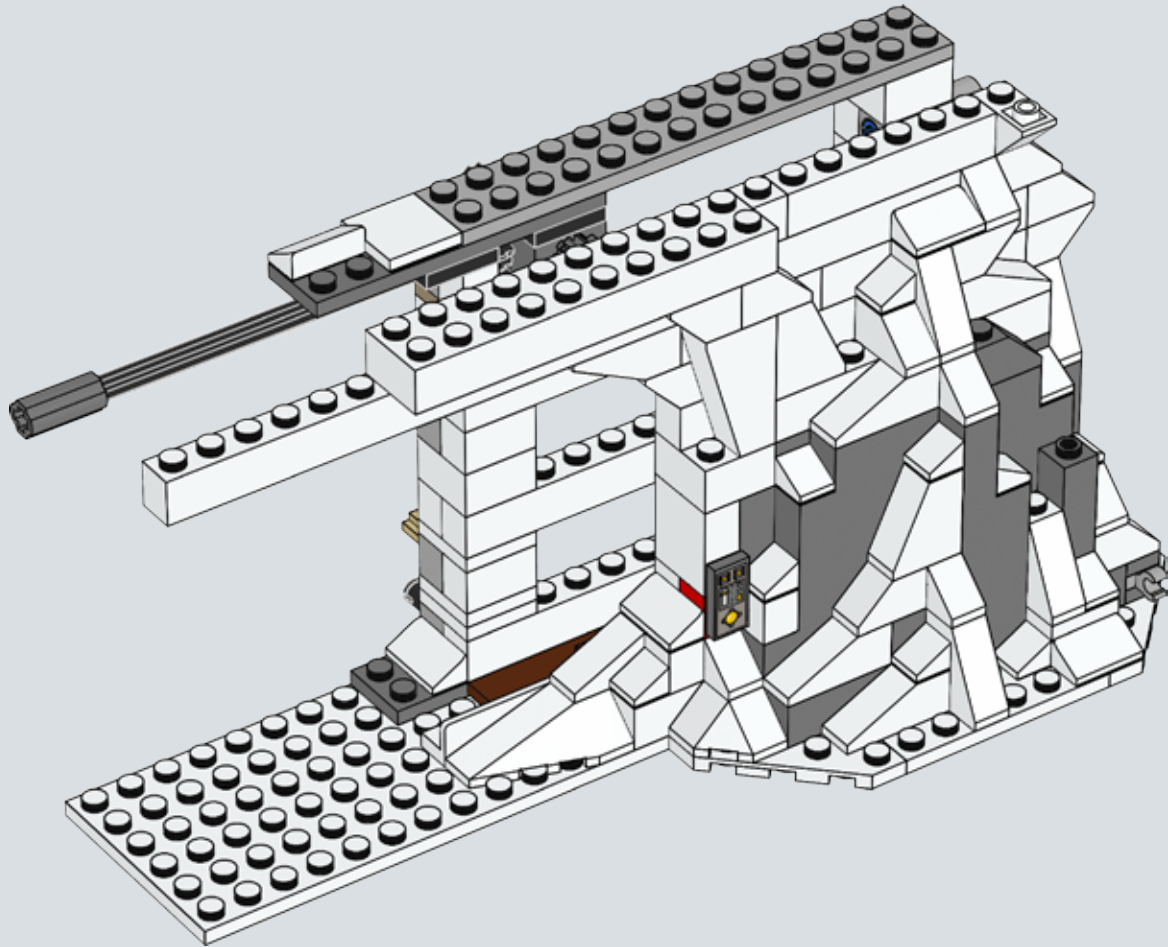

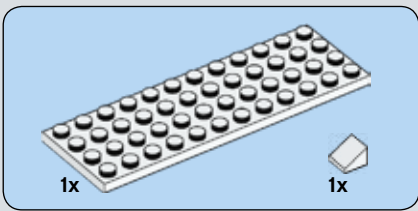

82

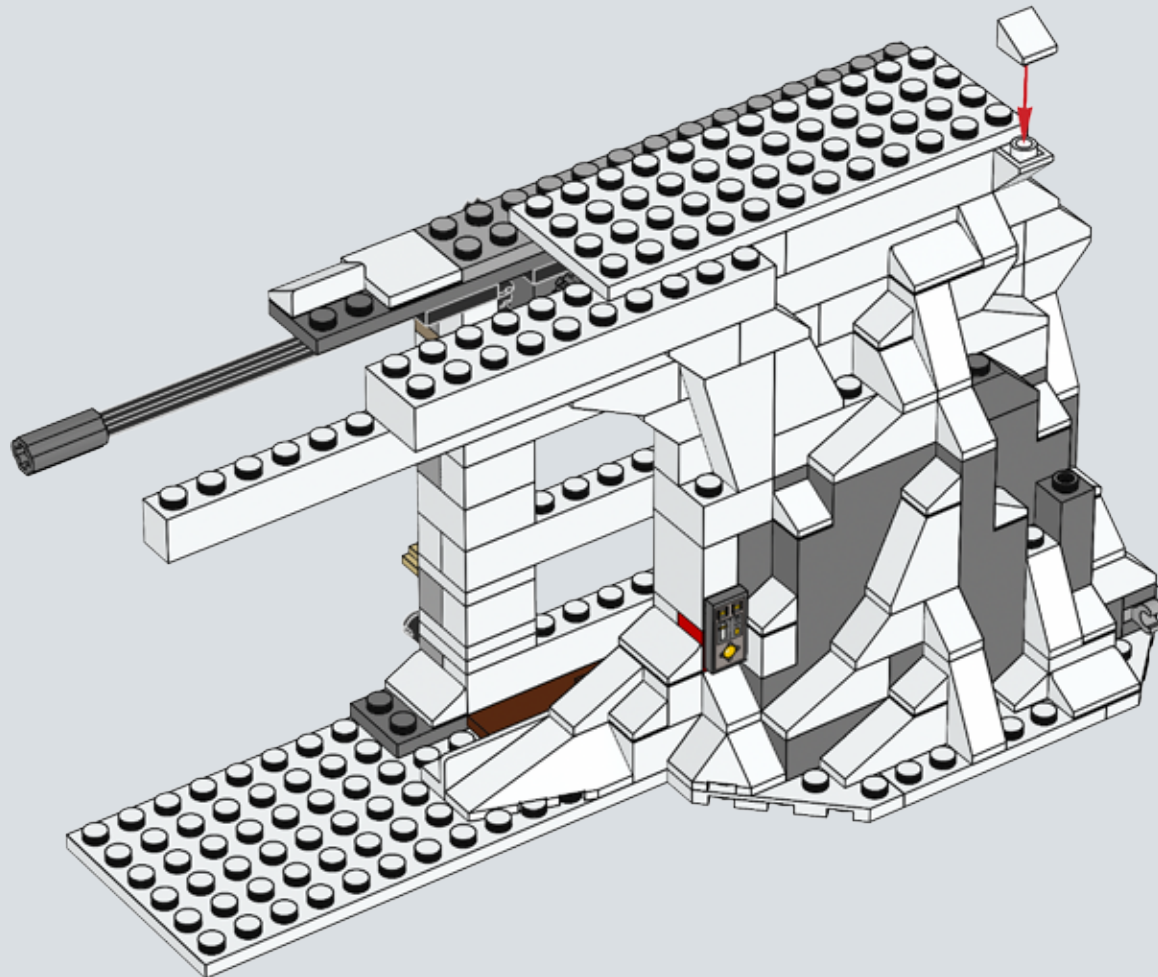

83

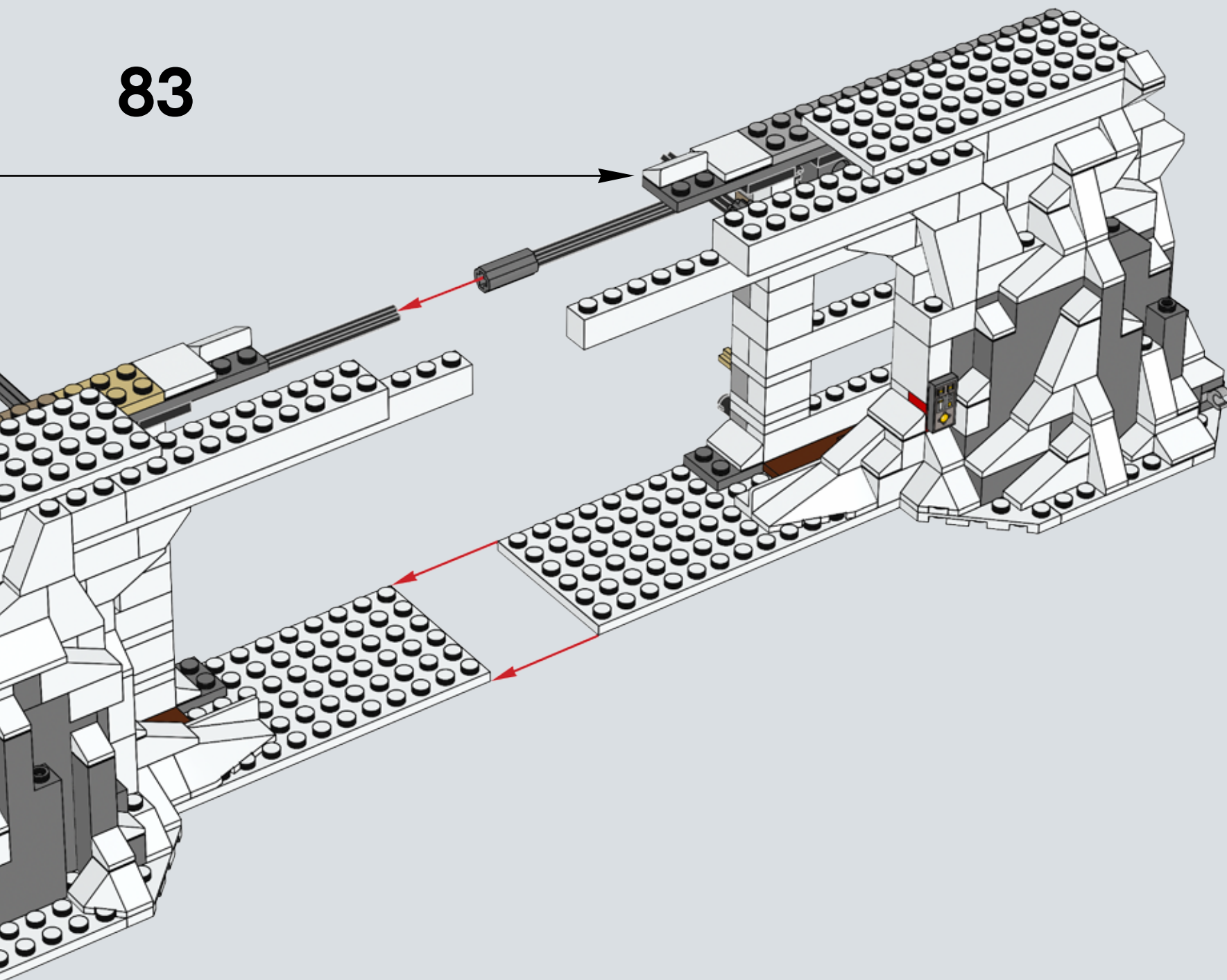



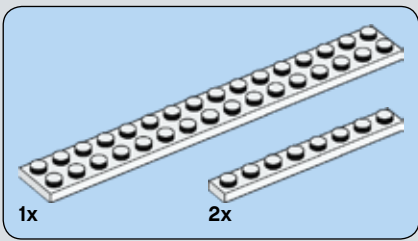

84

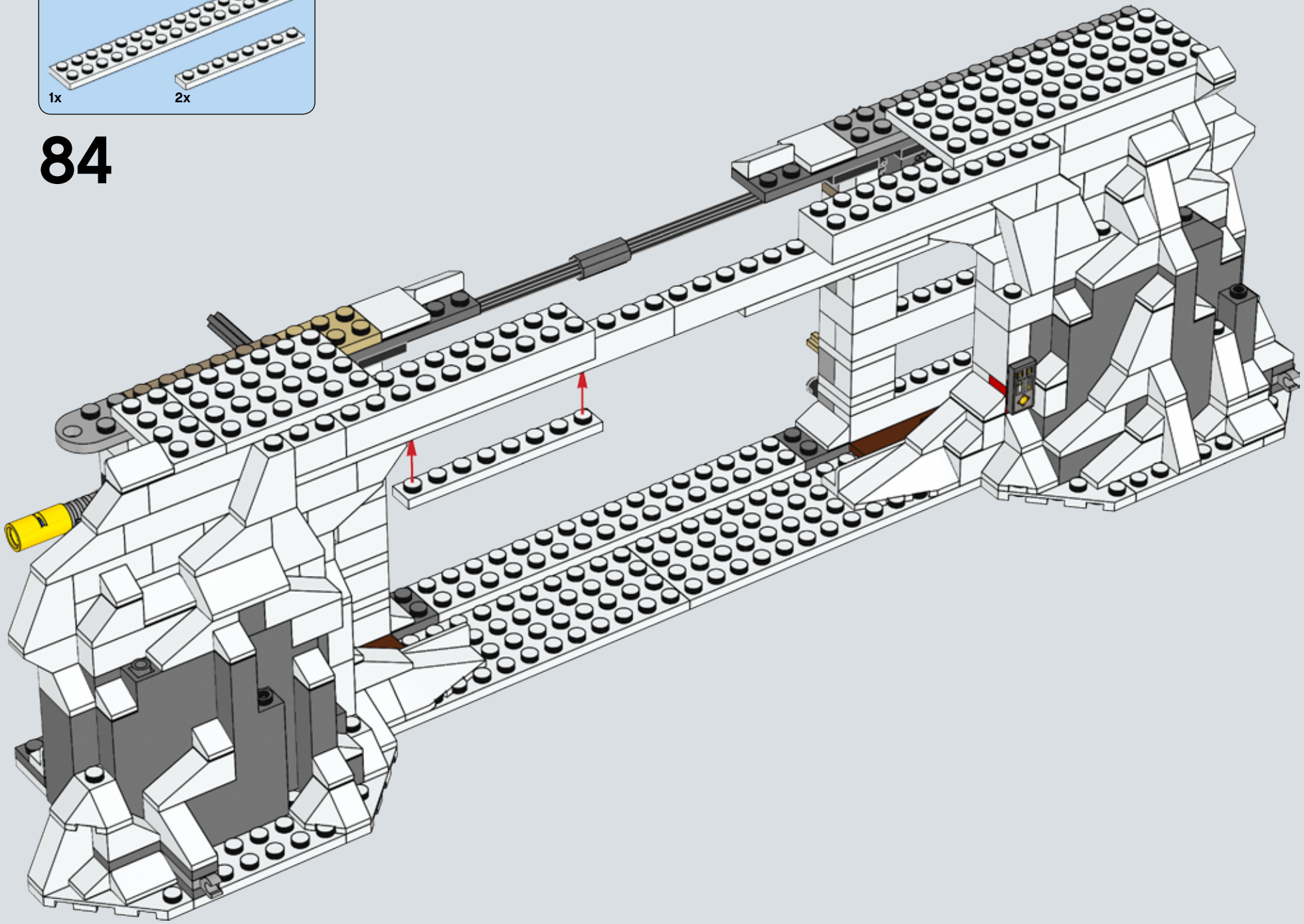

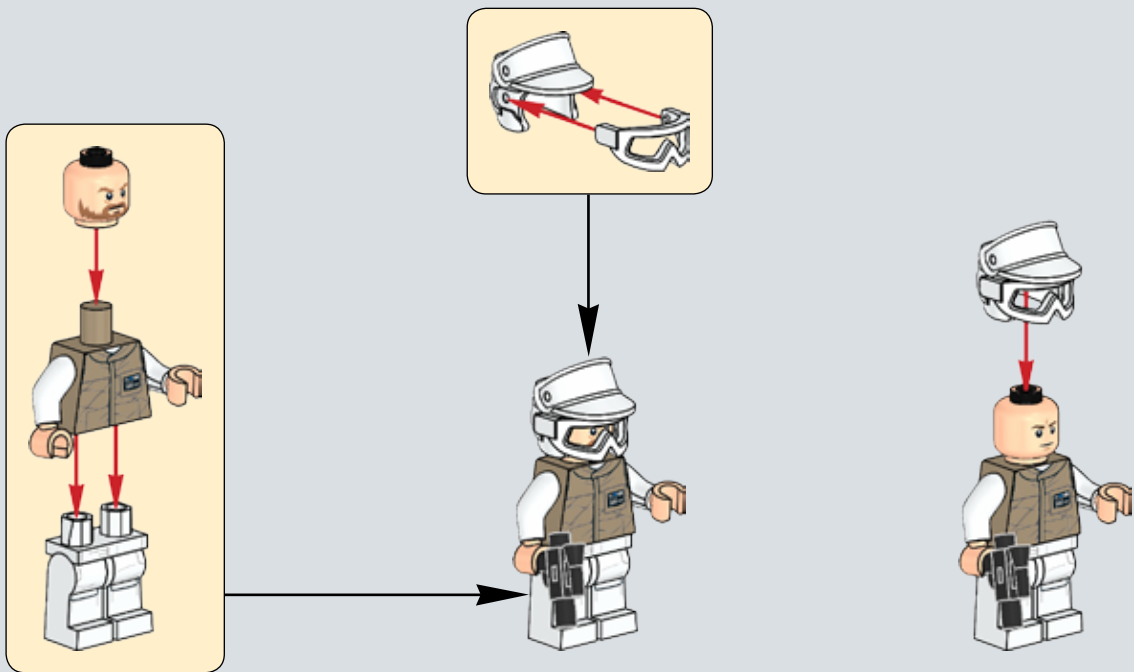
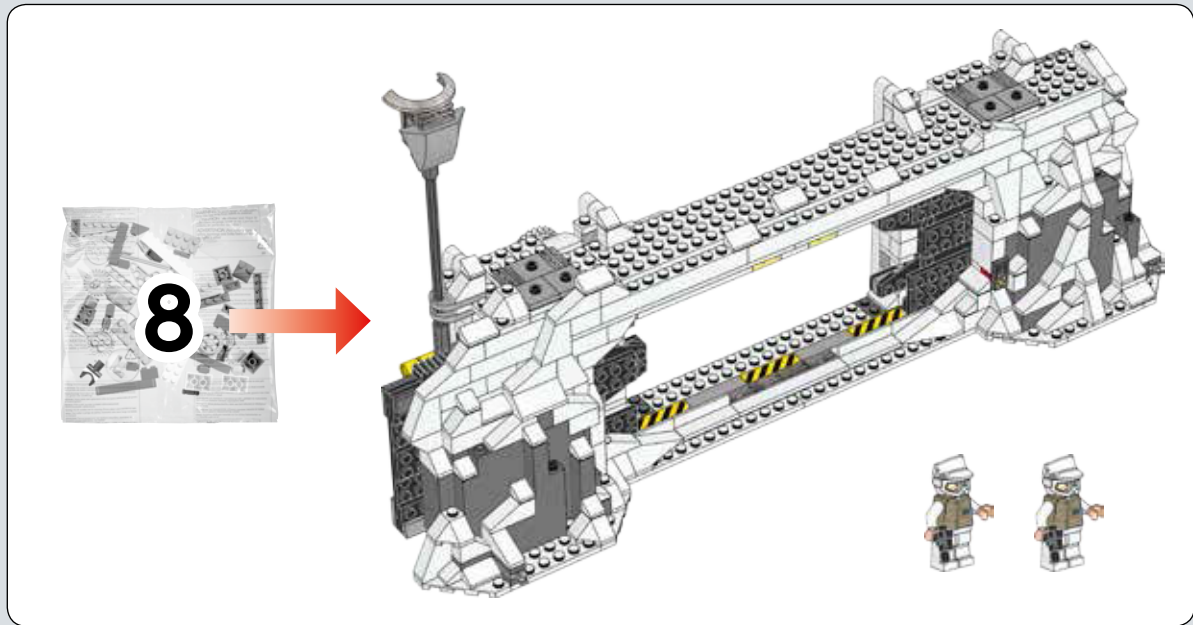



85

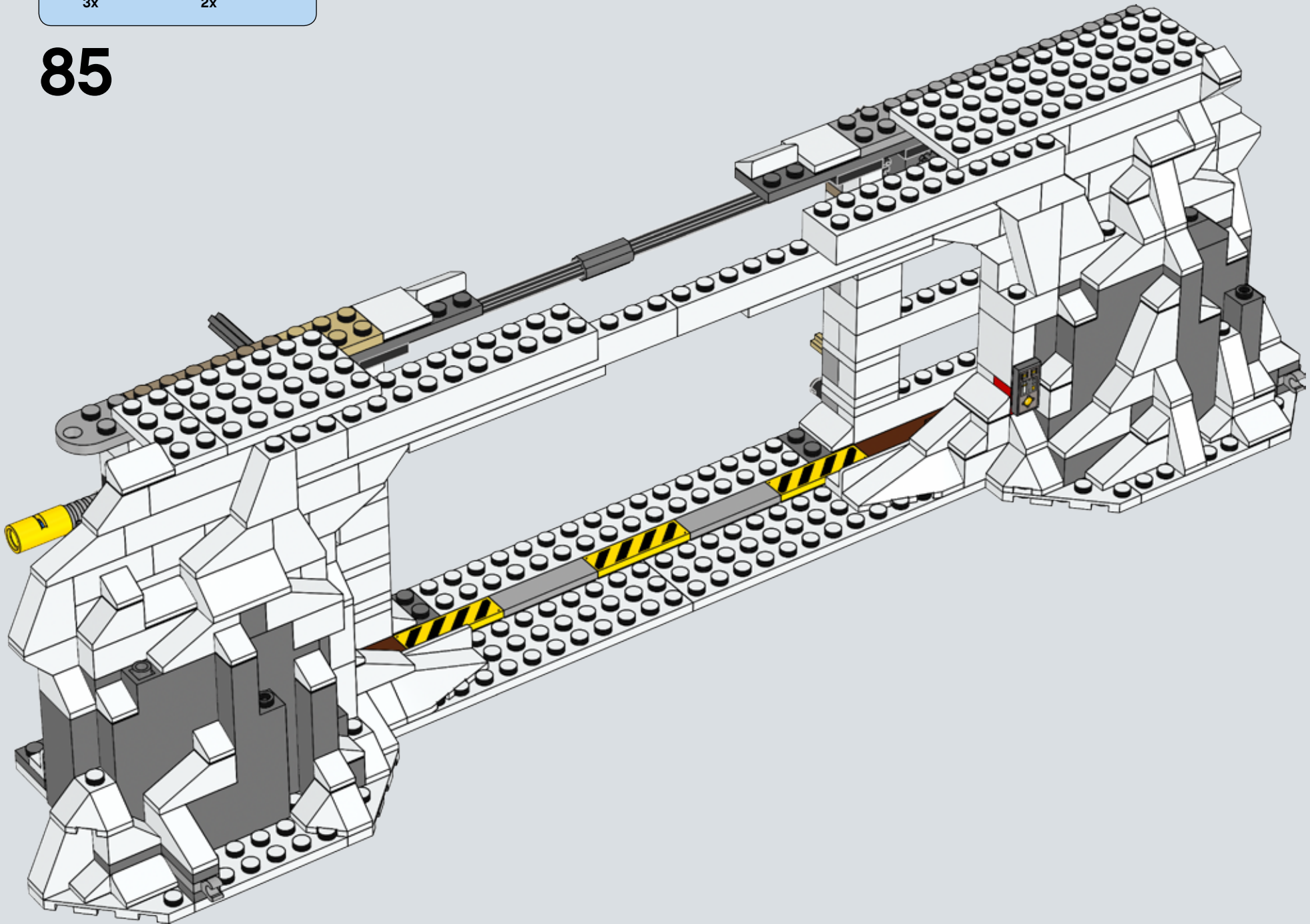



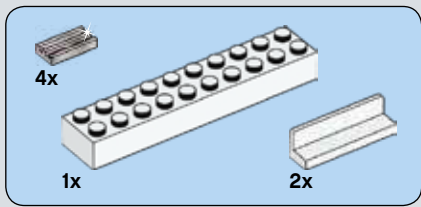

86

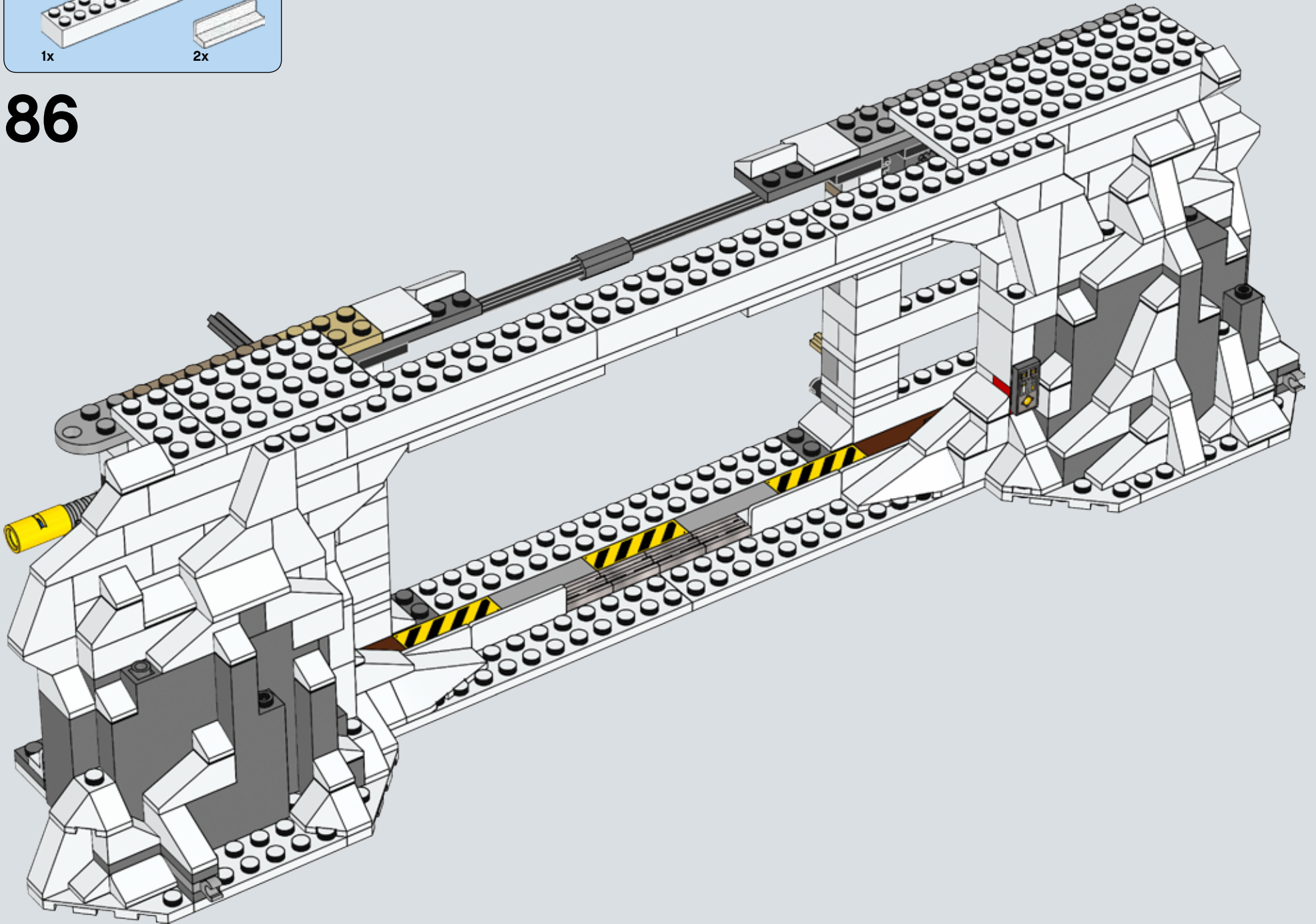



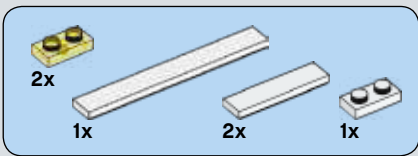

87

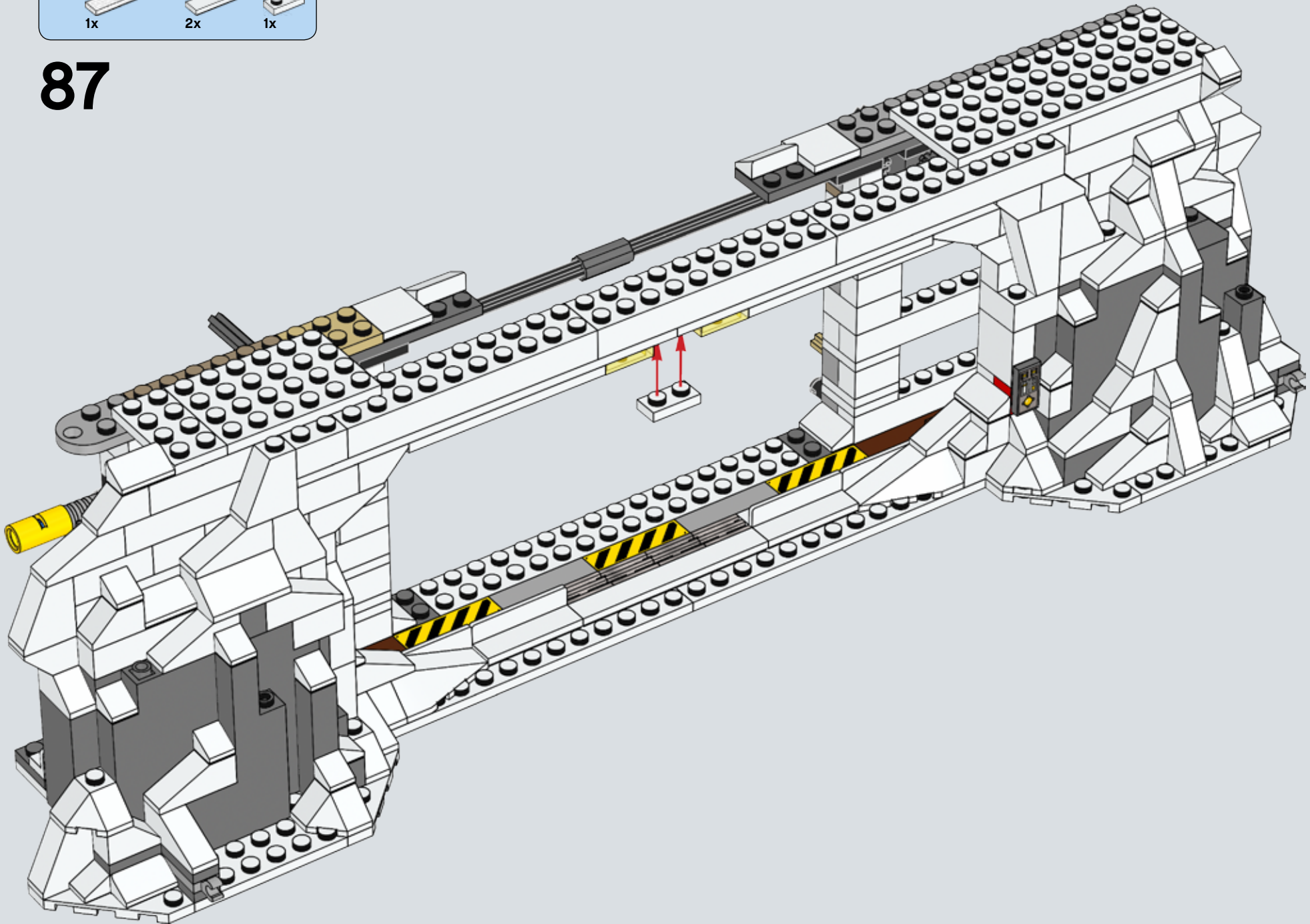

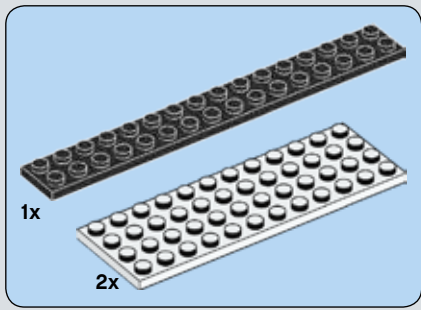

88

1

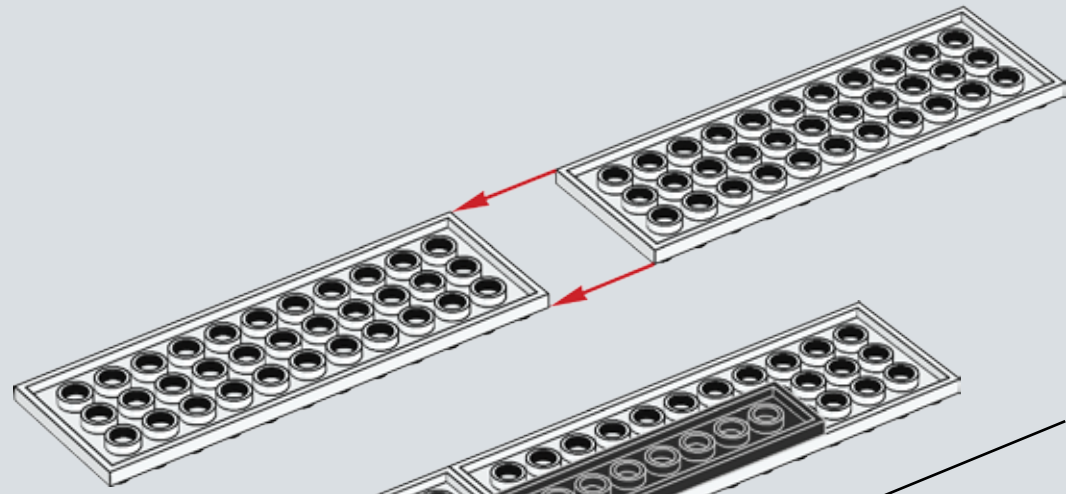

2

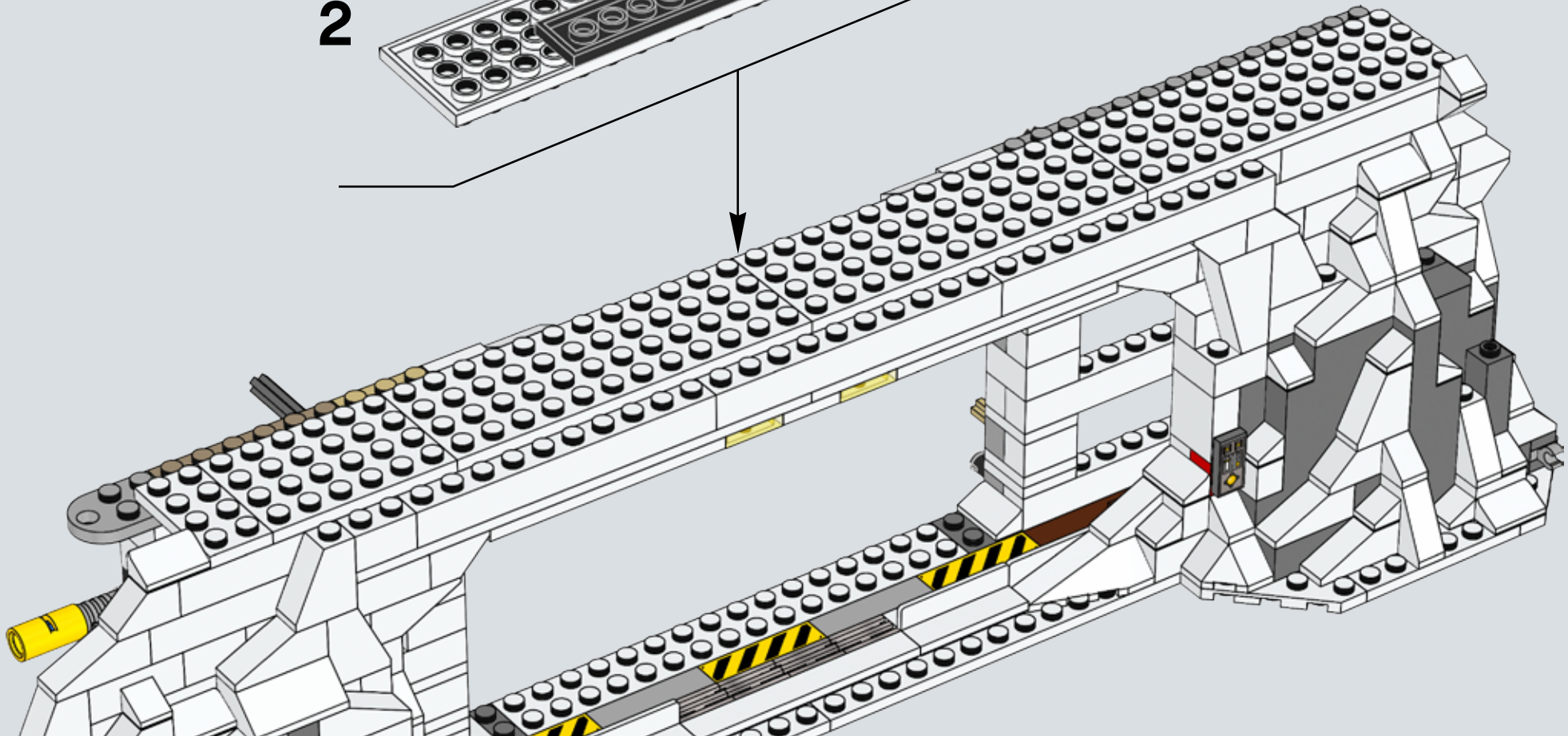
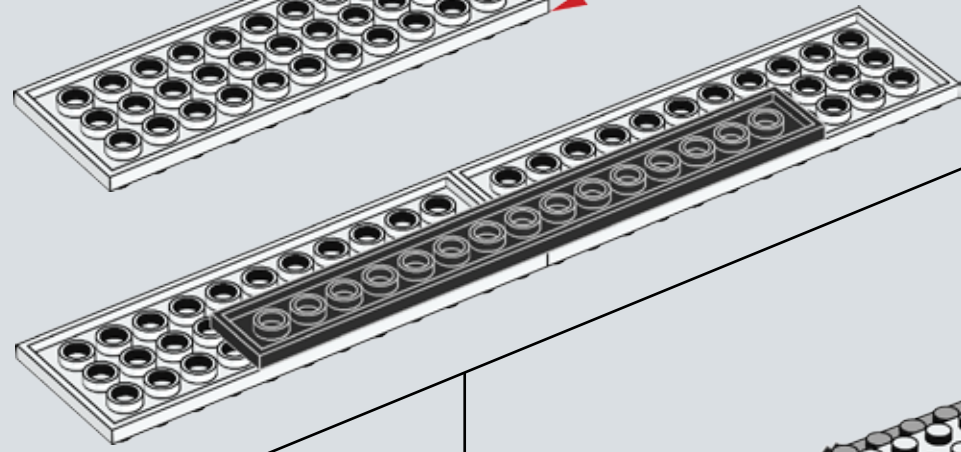





89

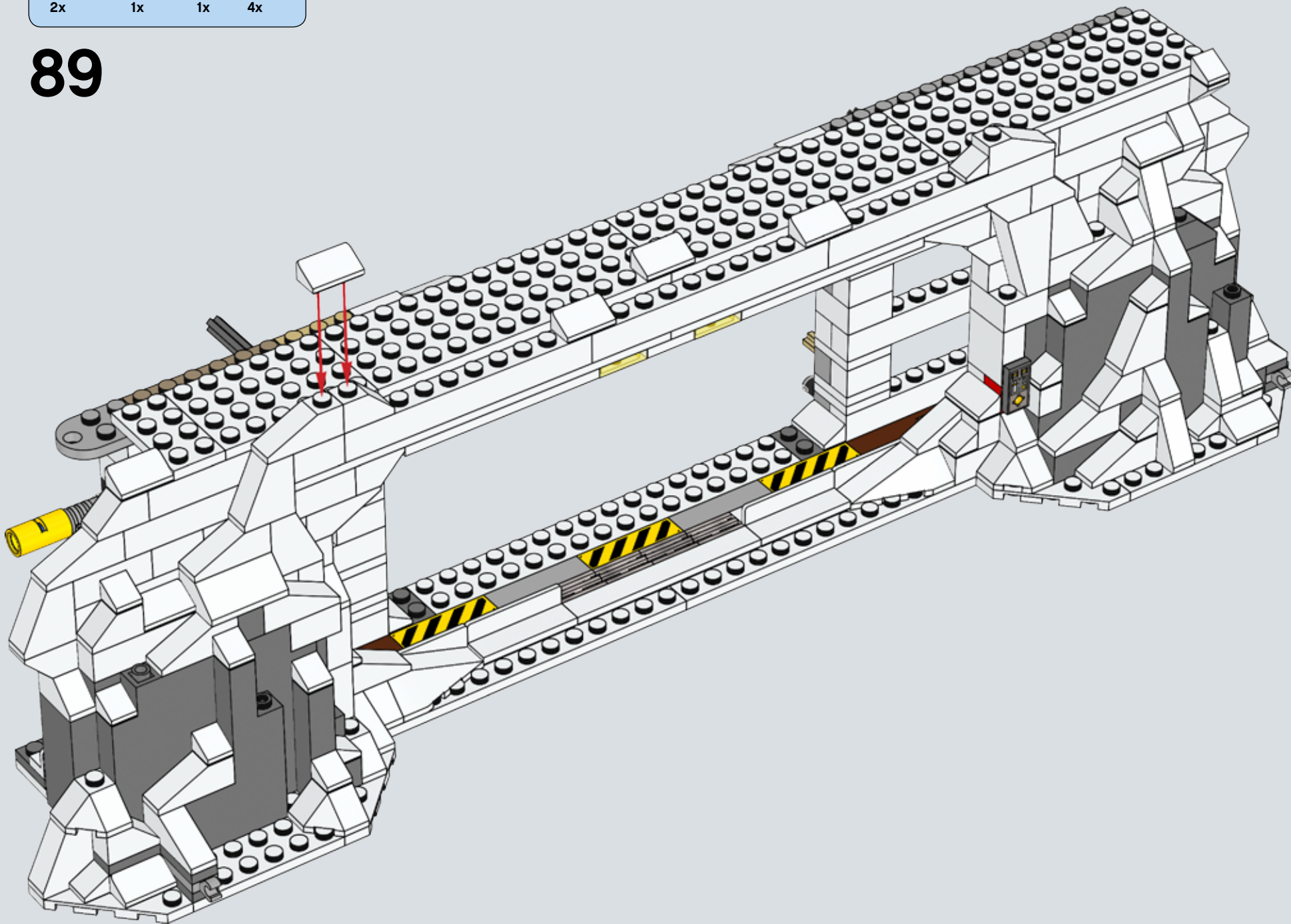

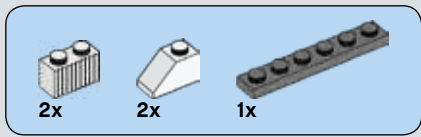

90

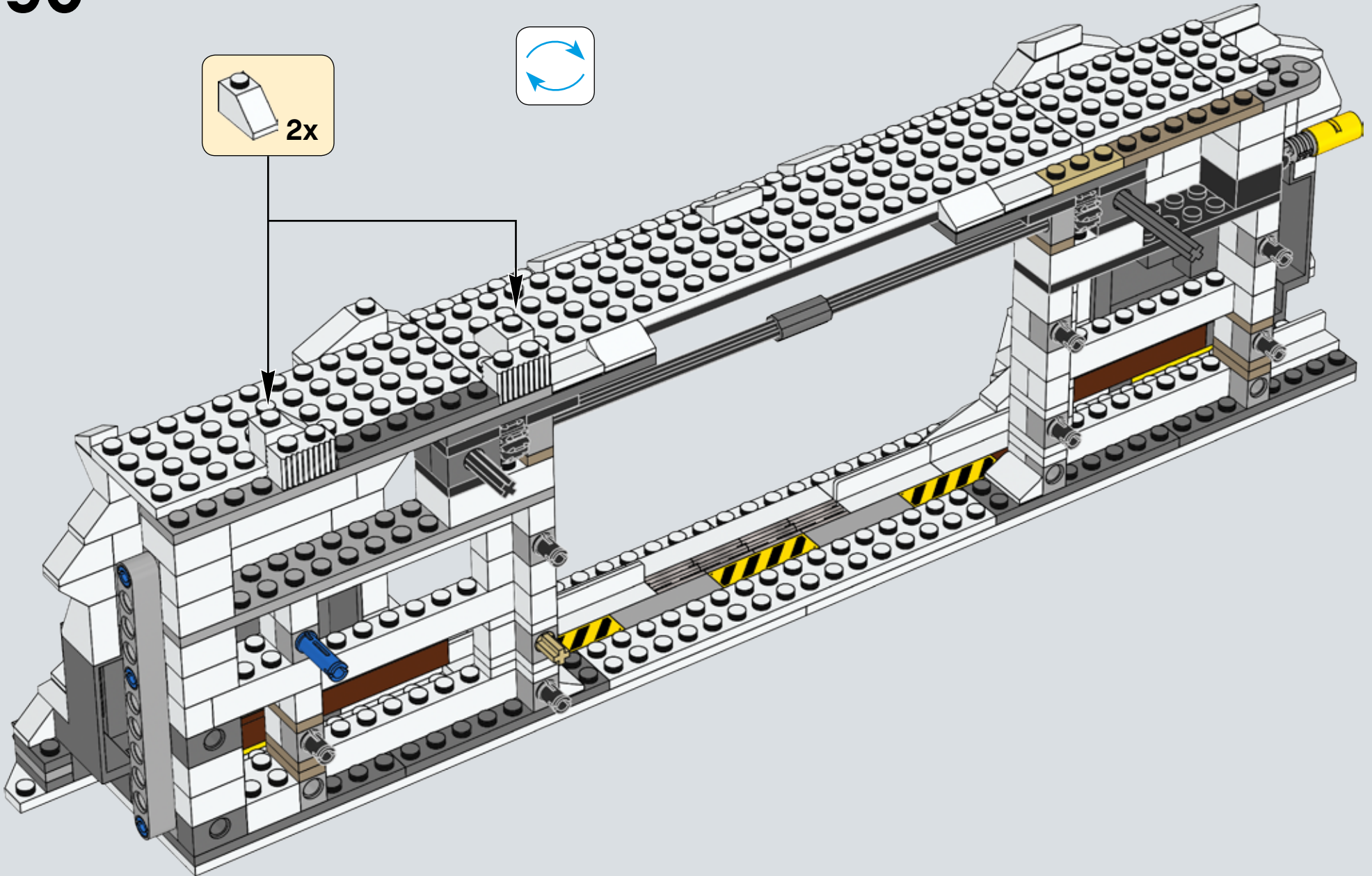
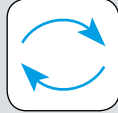
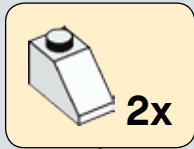



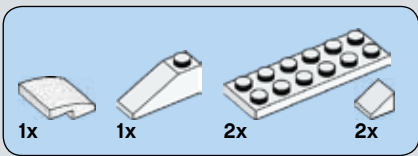

91

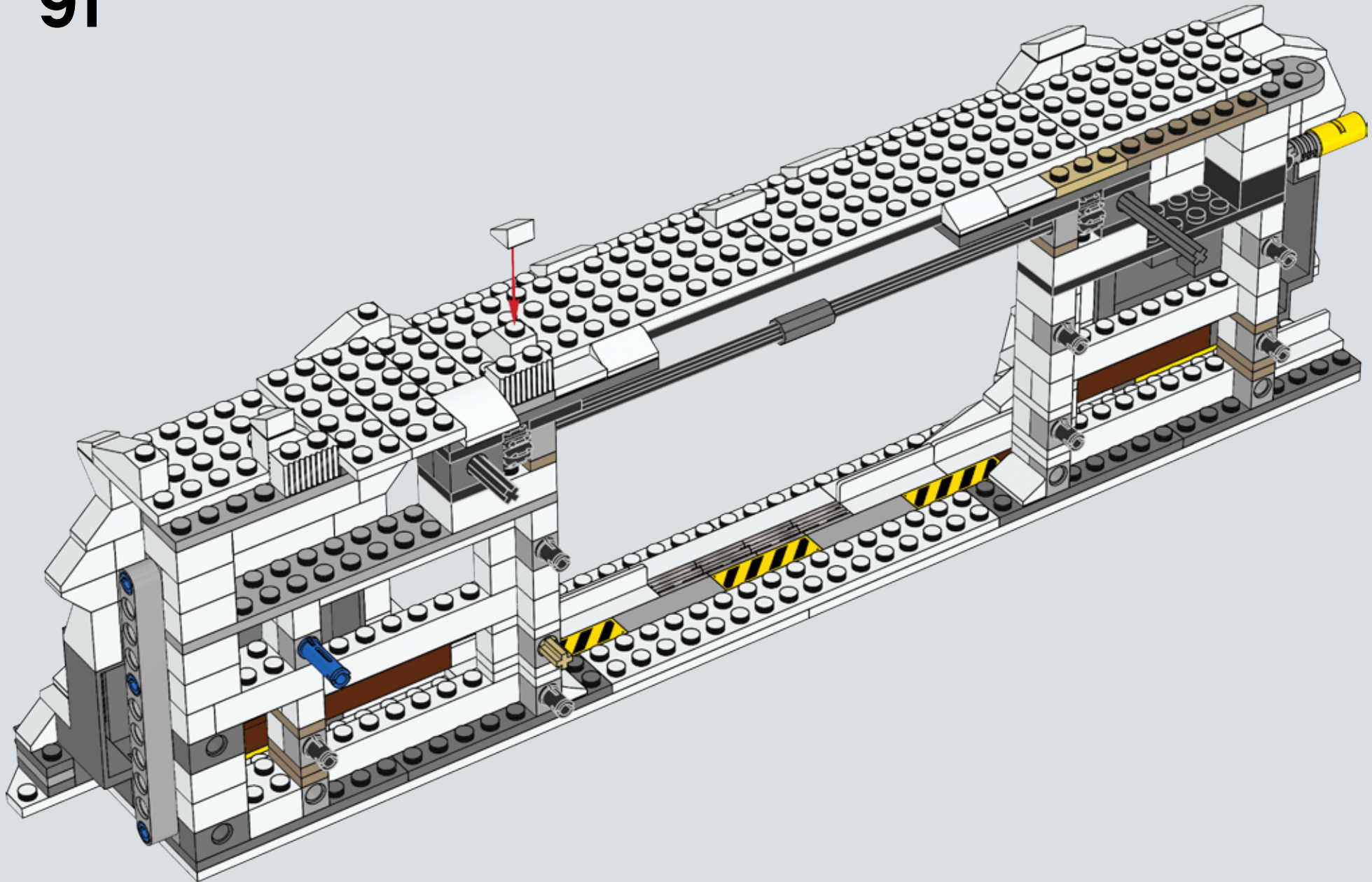

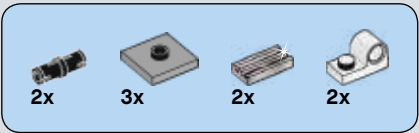

# 92

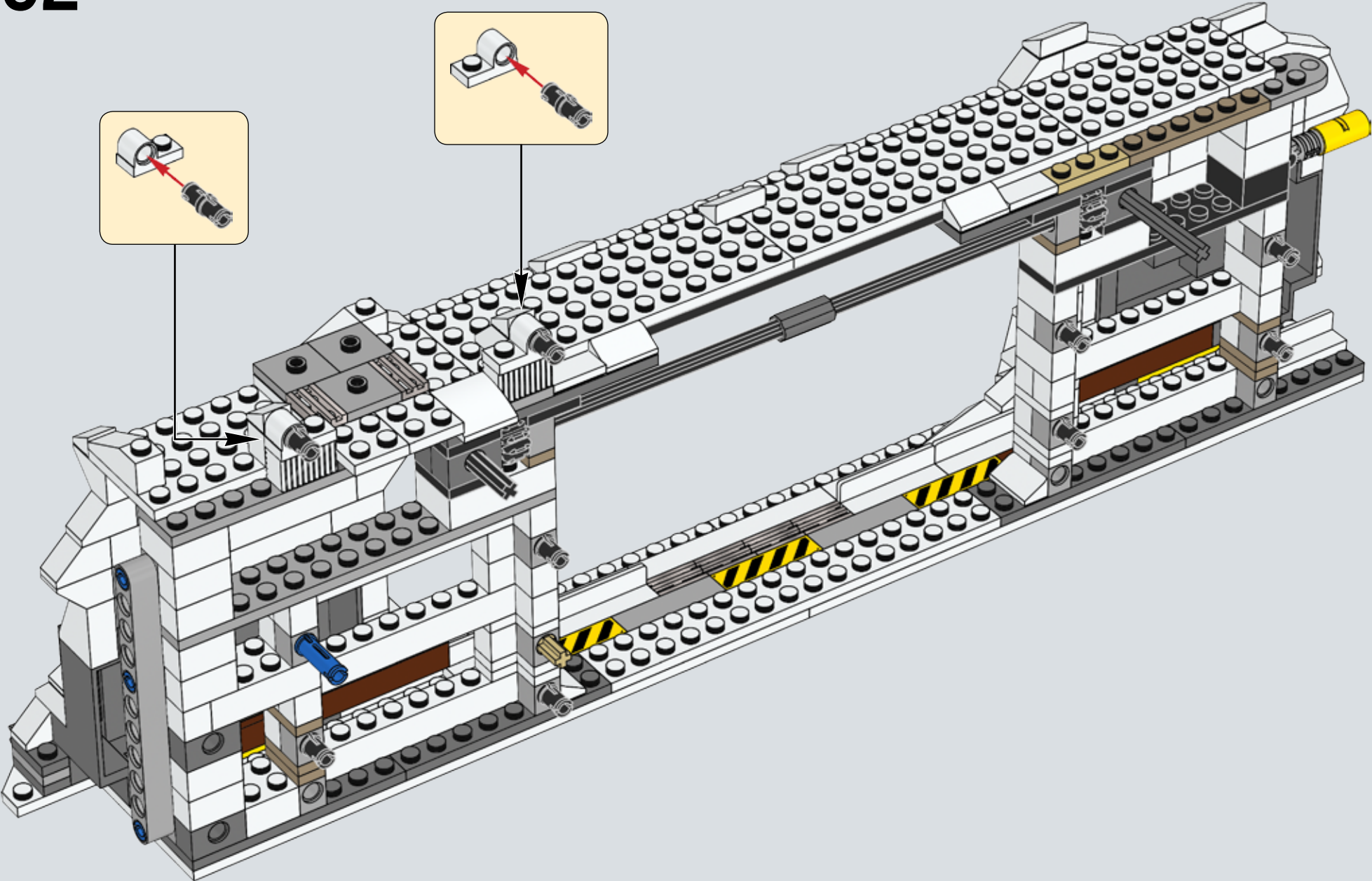



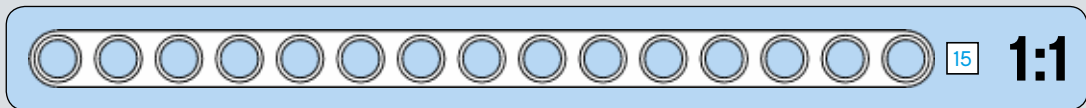
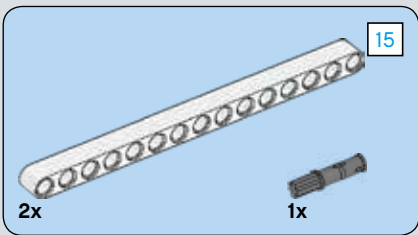

93

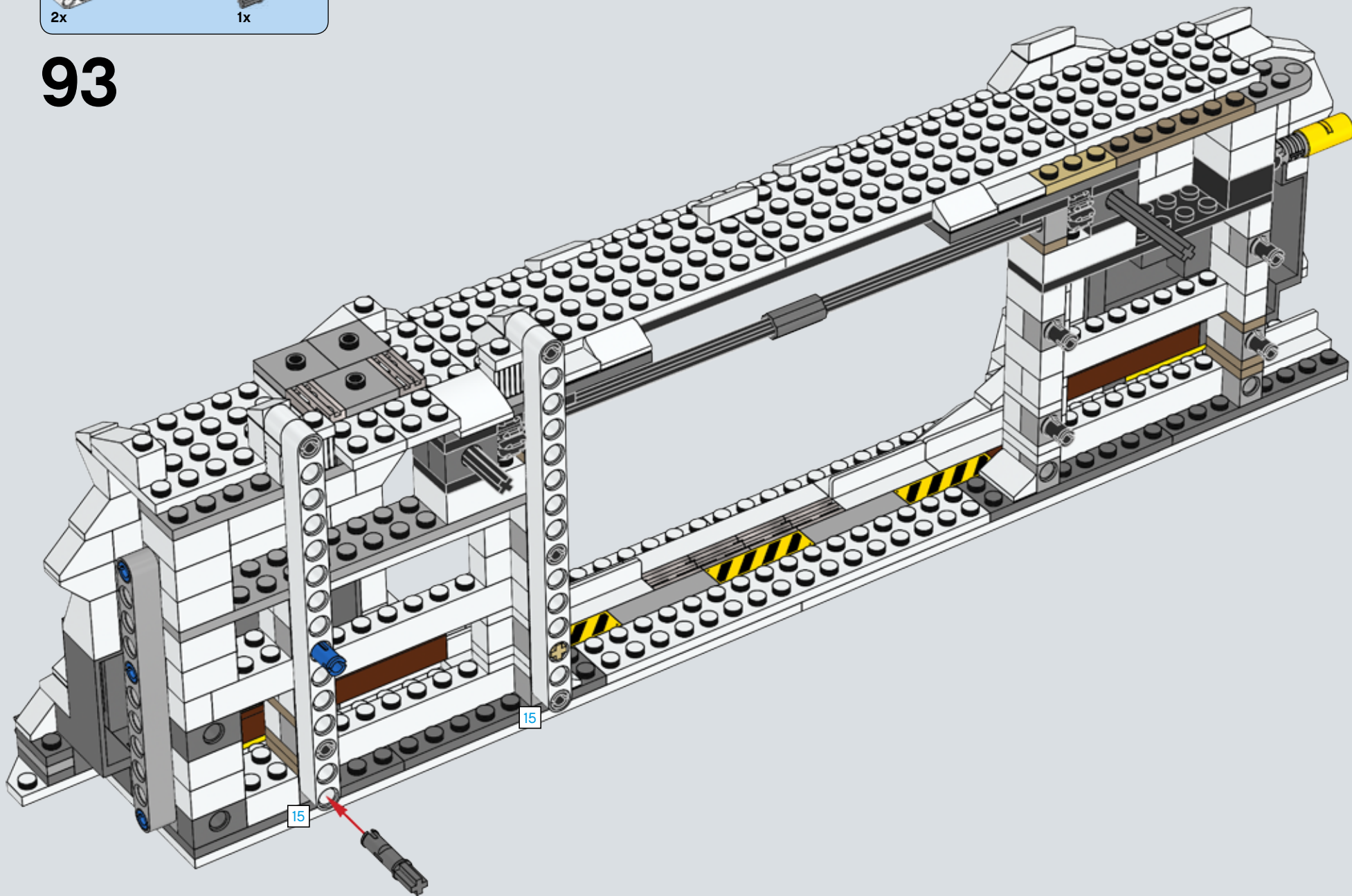

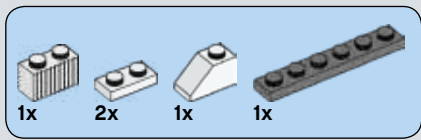

94

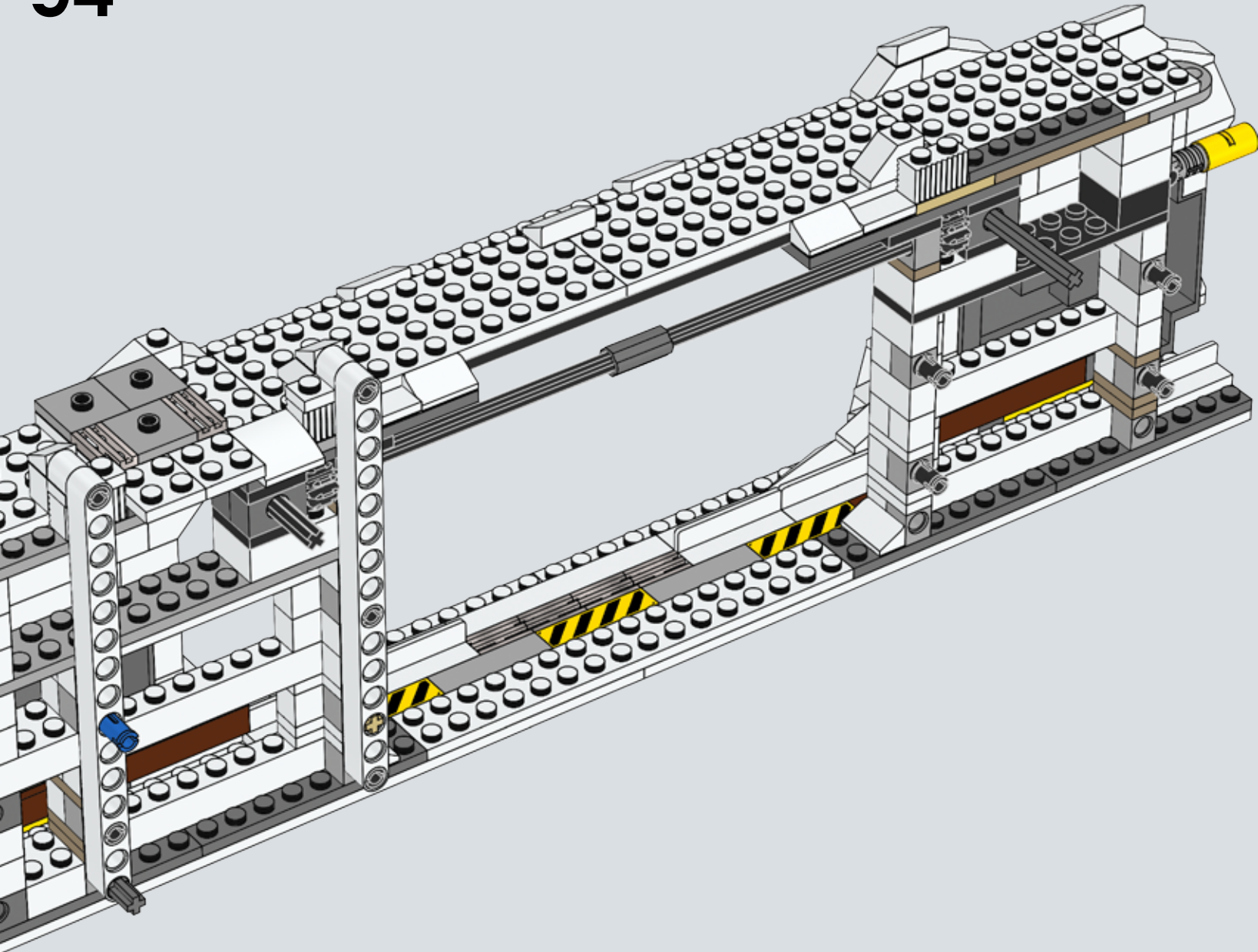



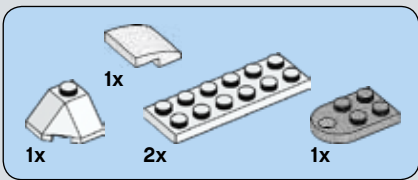

95

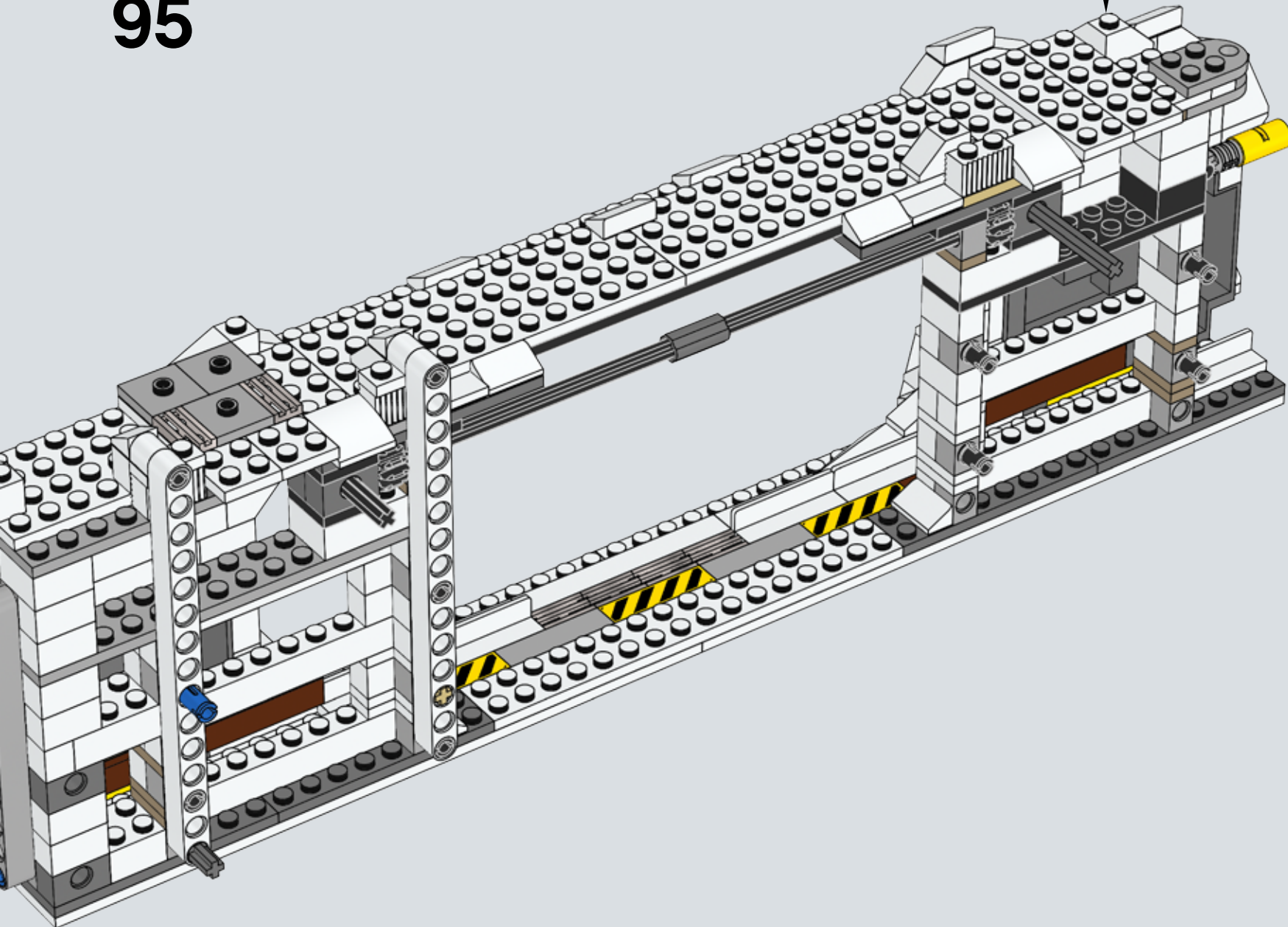

1x 3x 2x

# 96

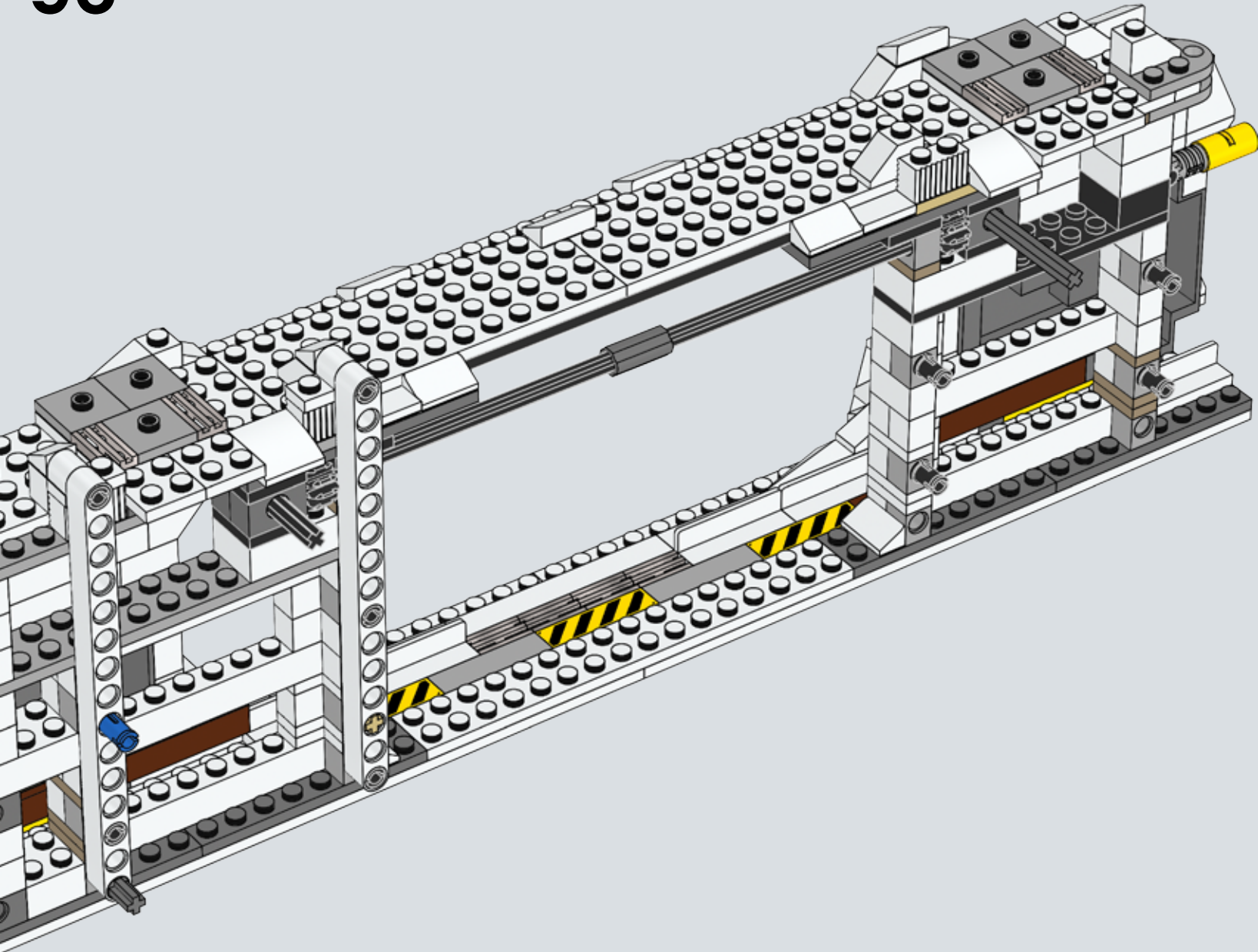



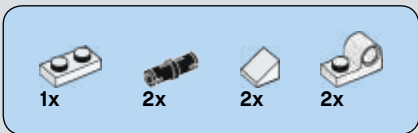

97

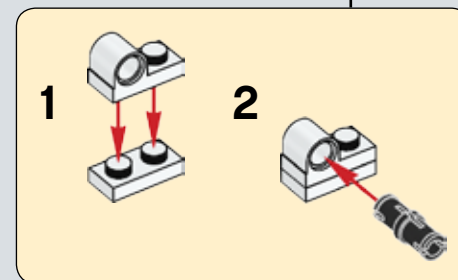
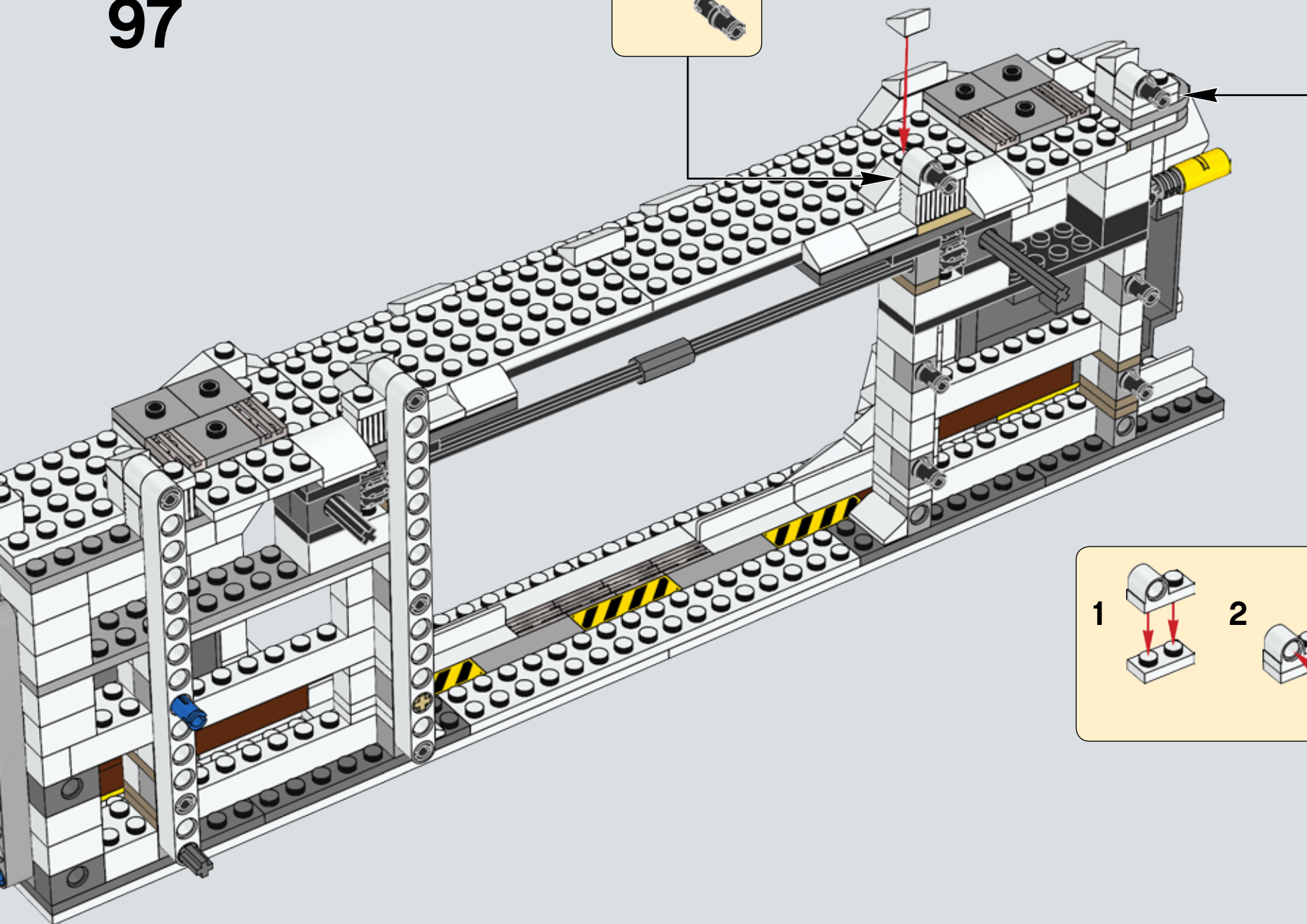
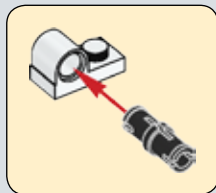

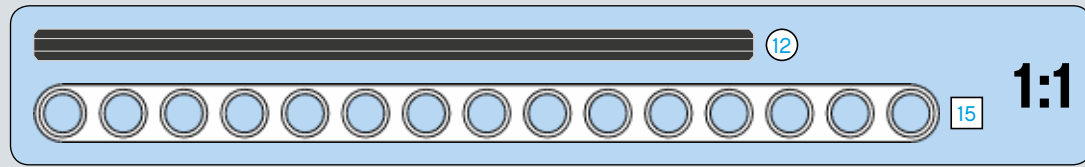
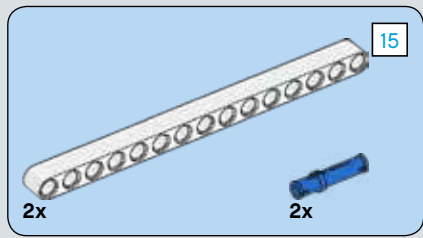

98

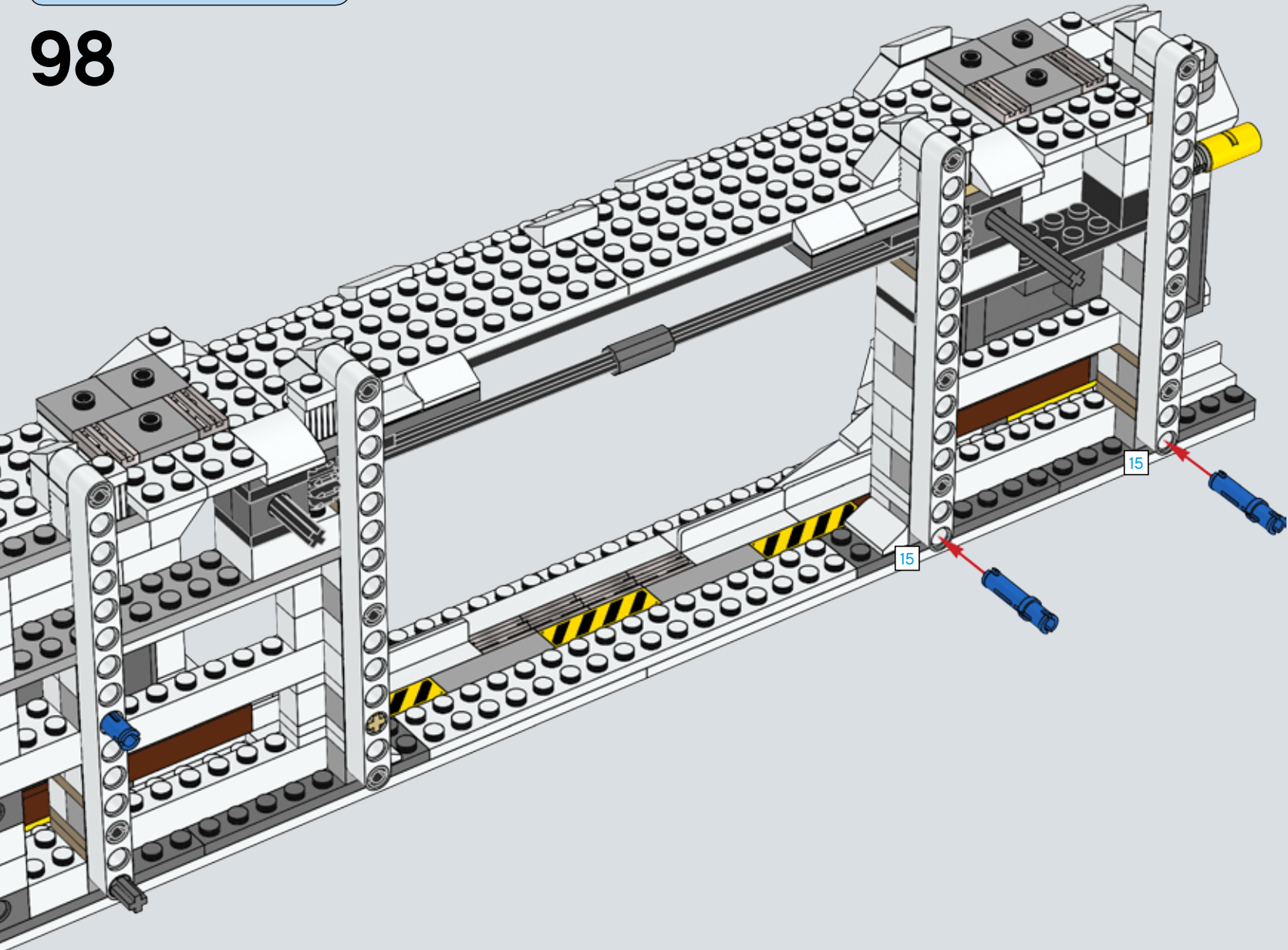



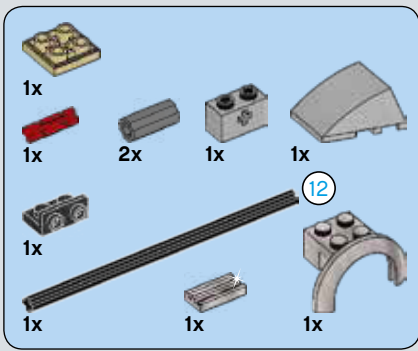

99

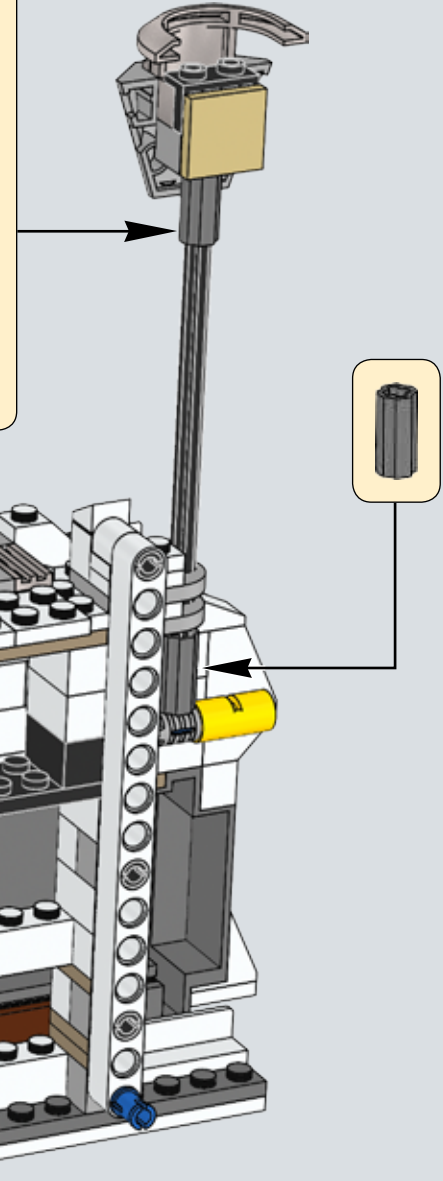
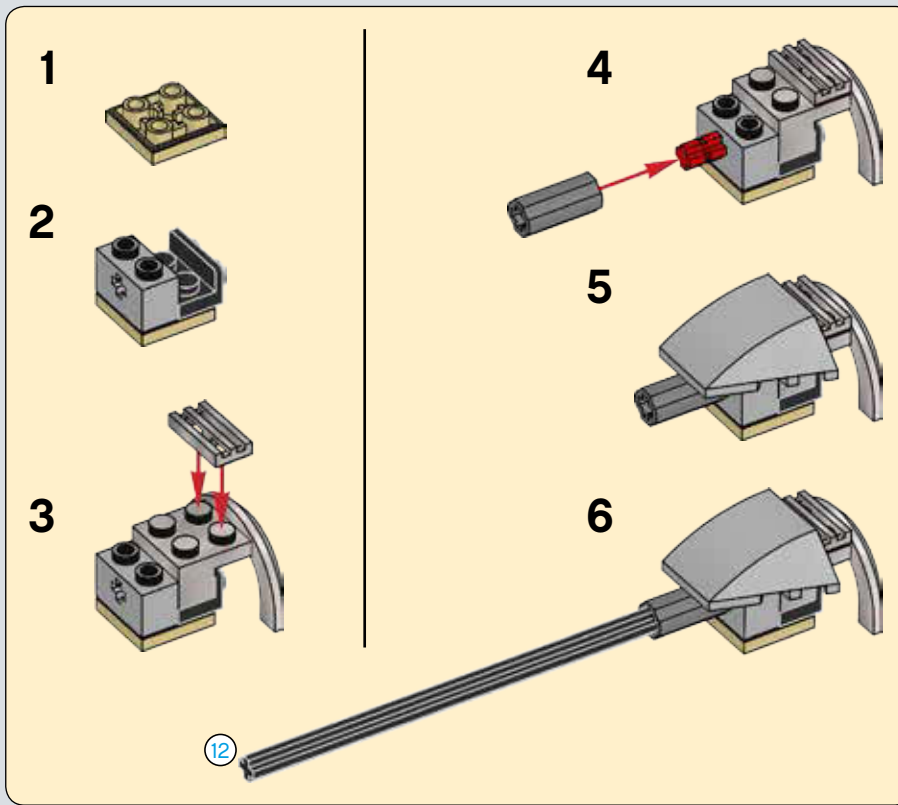

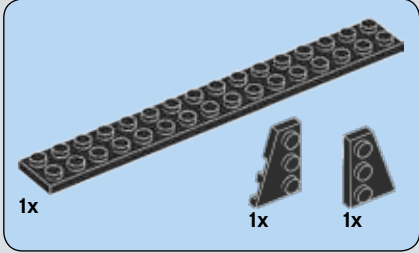
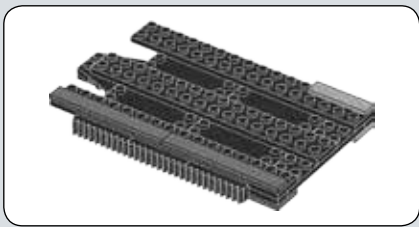

100

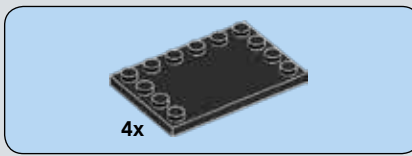
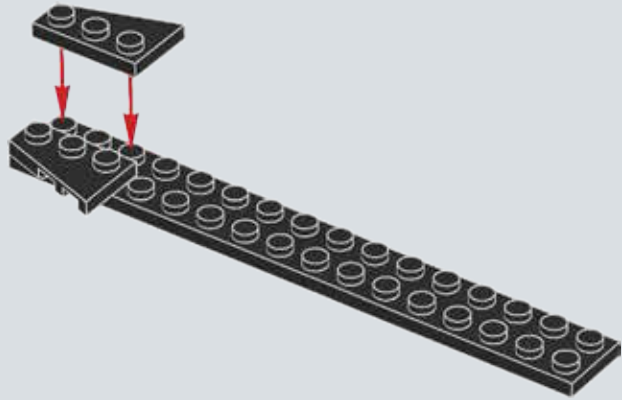

101

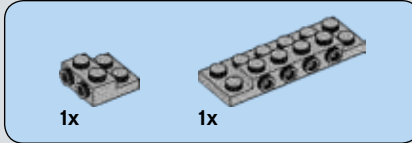
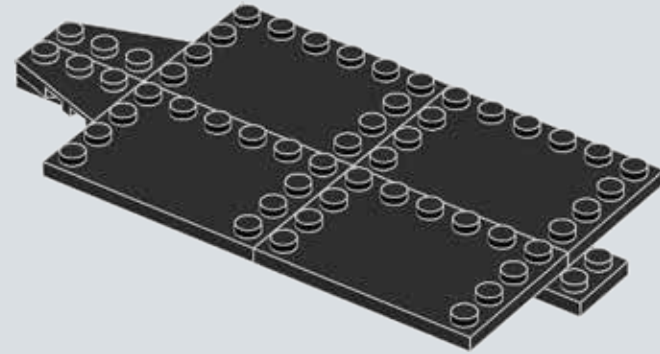

102

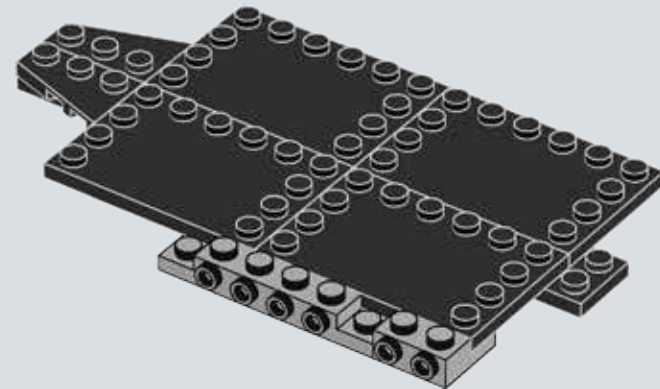

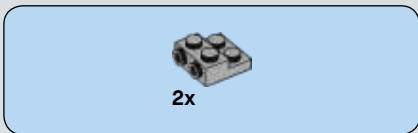

# 103

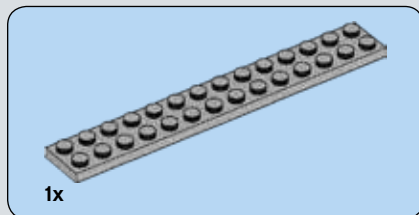
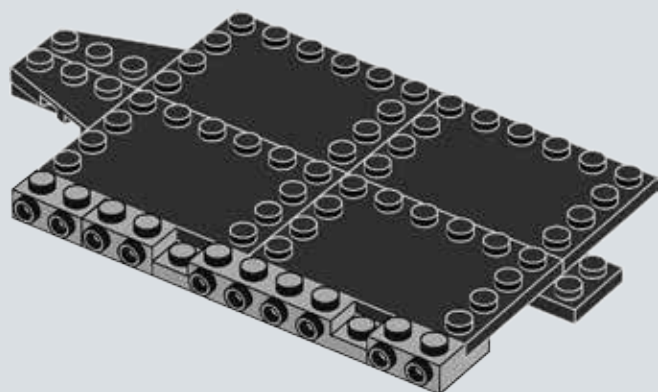

# 104

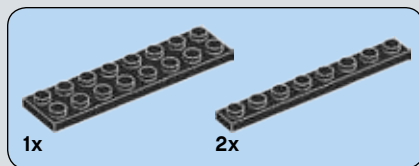
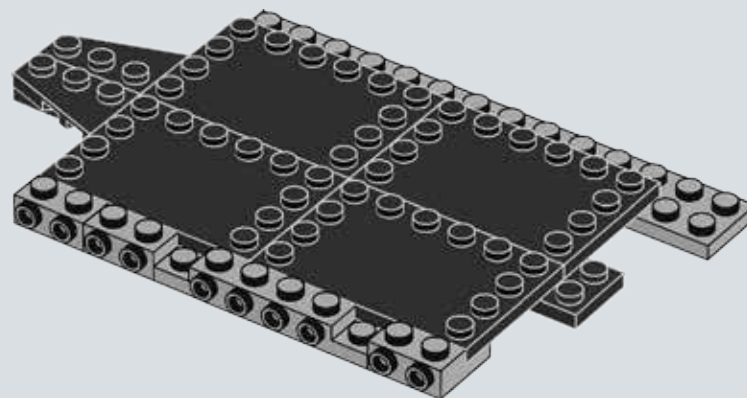

# 105

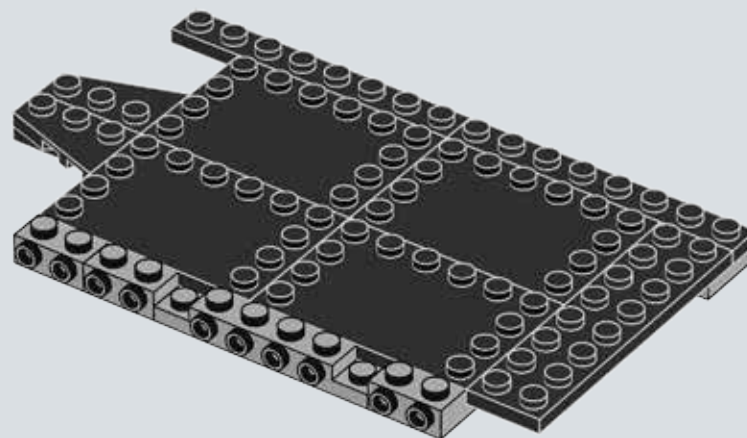

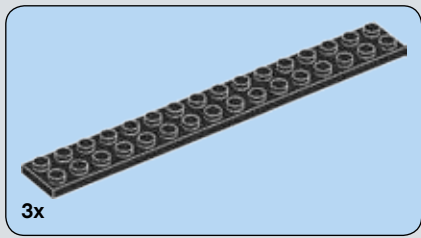

106

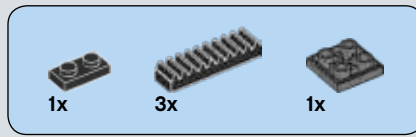
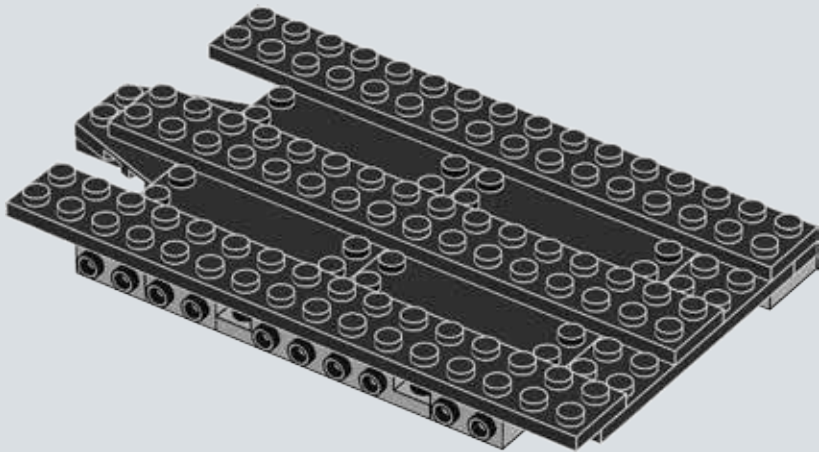

107

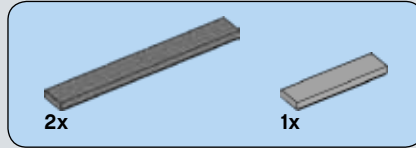
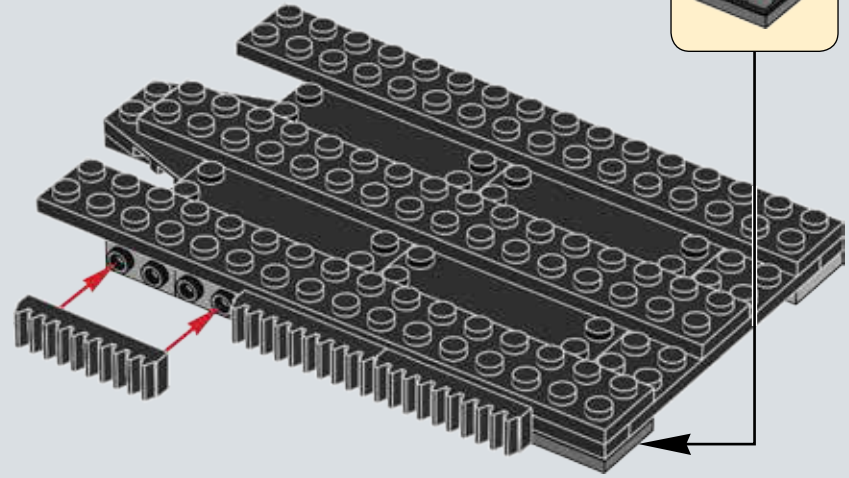

108

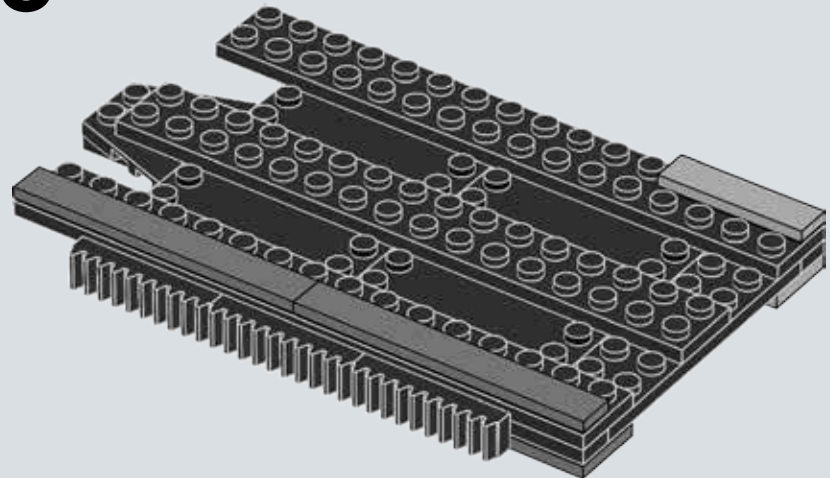



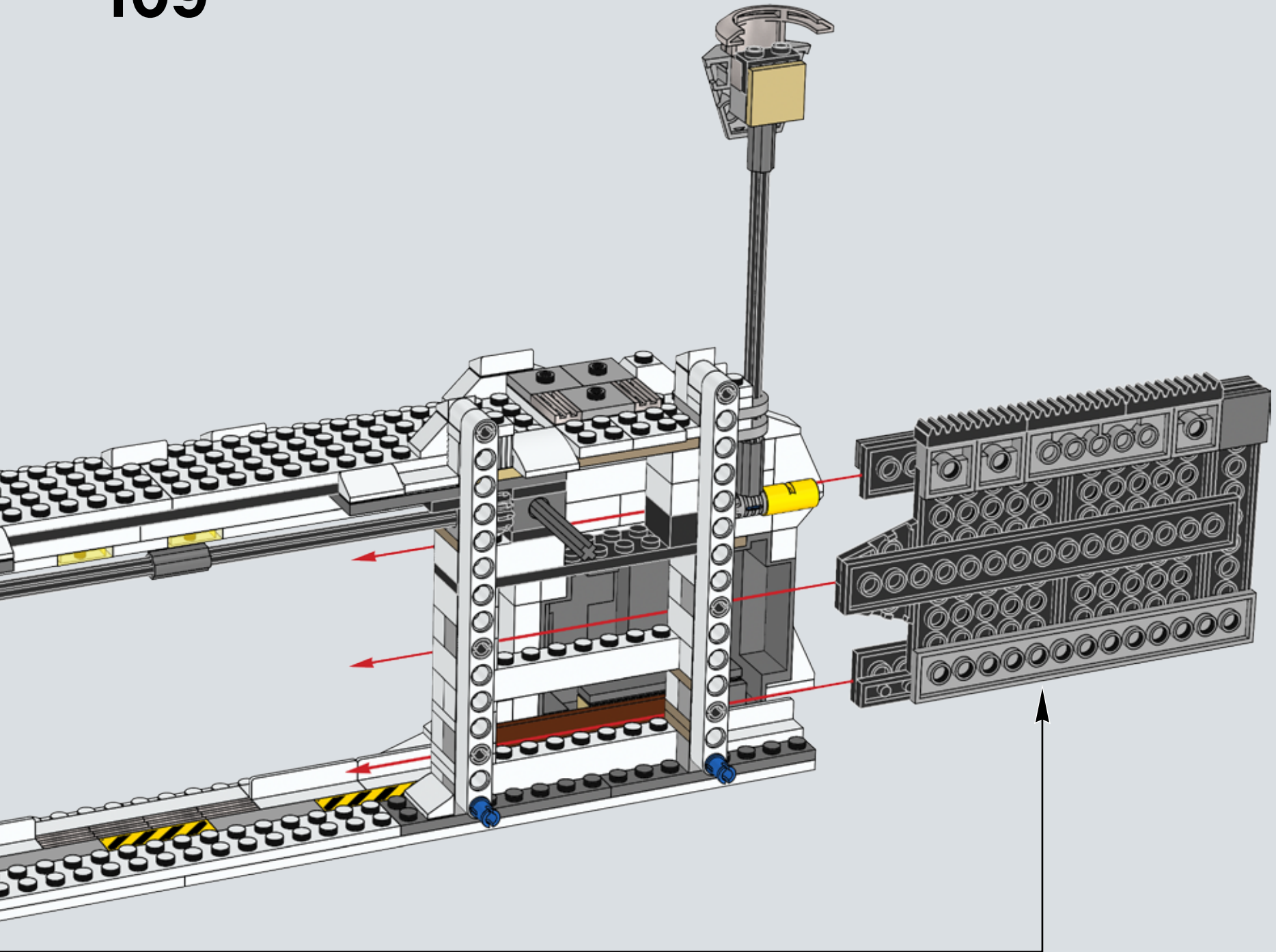



1x

# 110

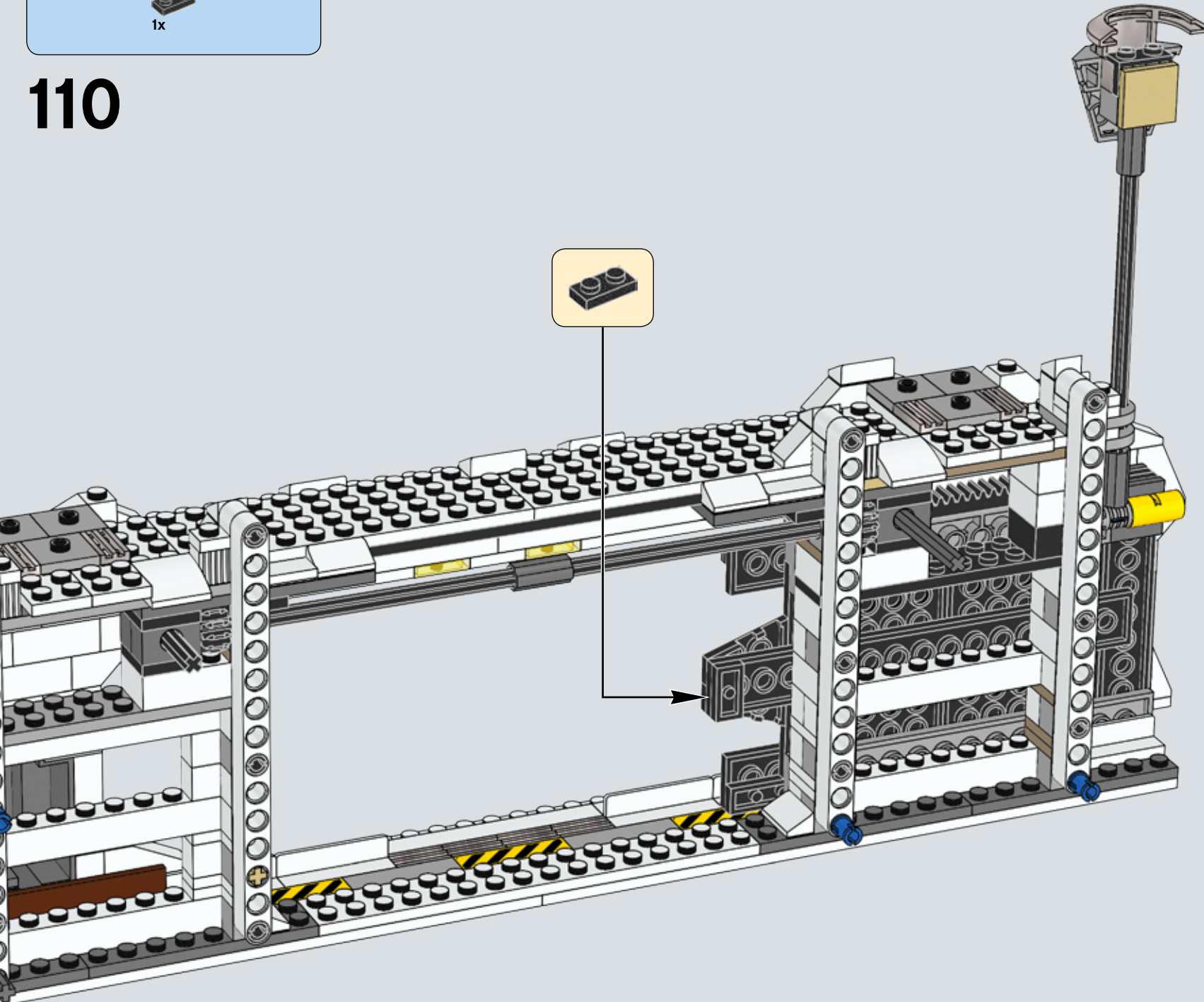
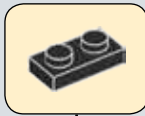

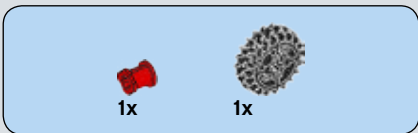

111

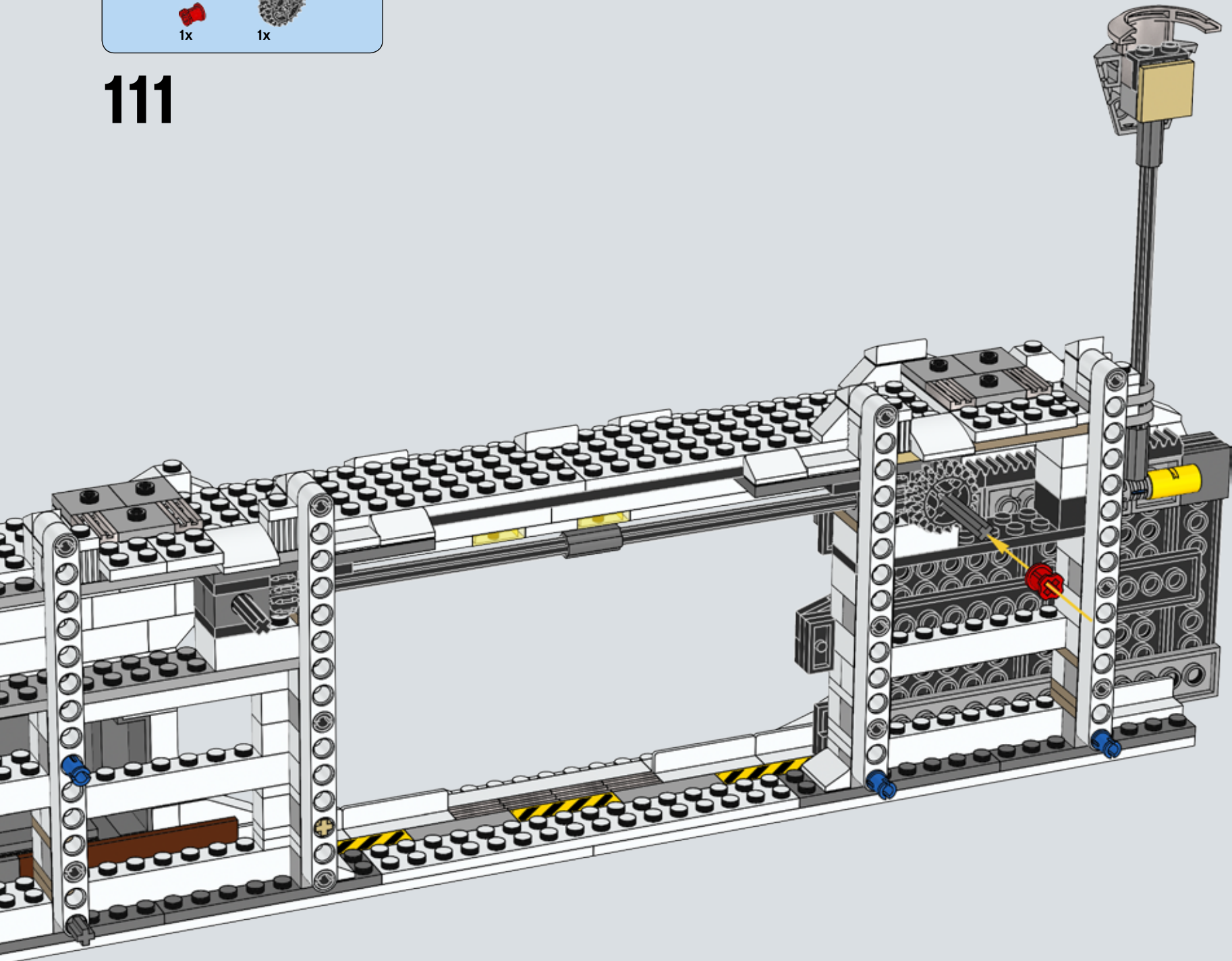



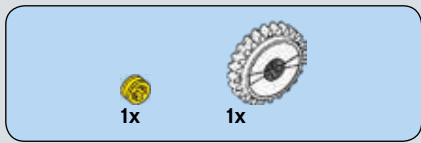

112

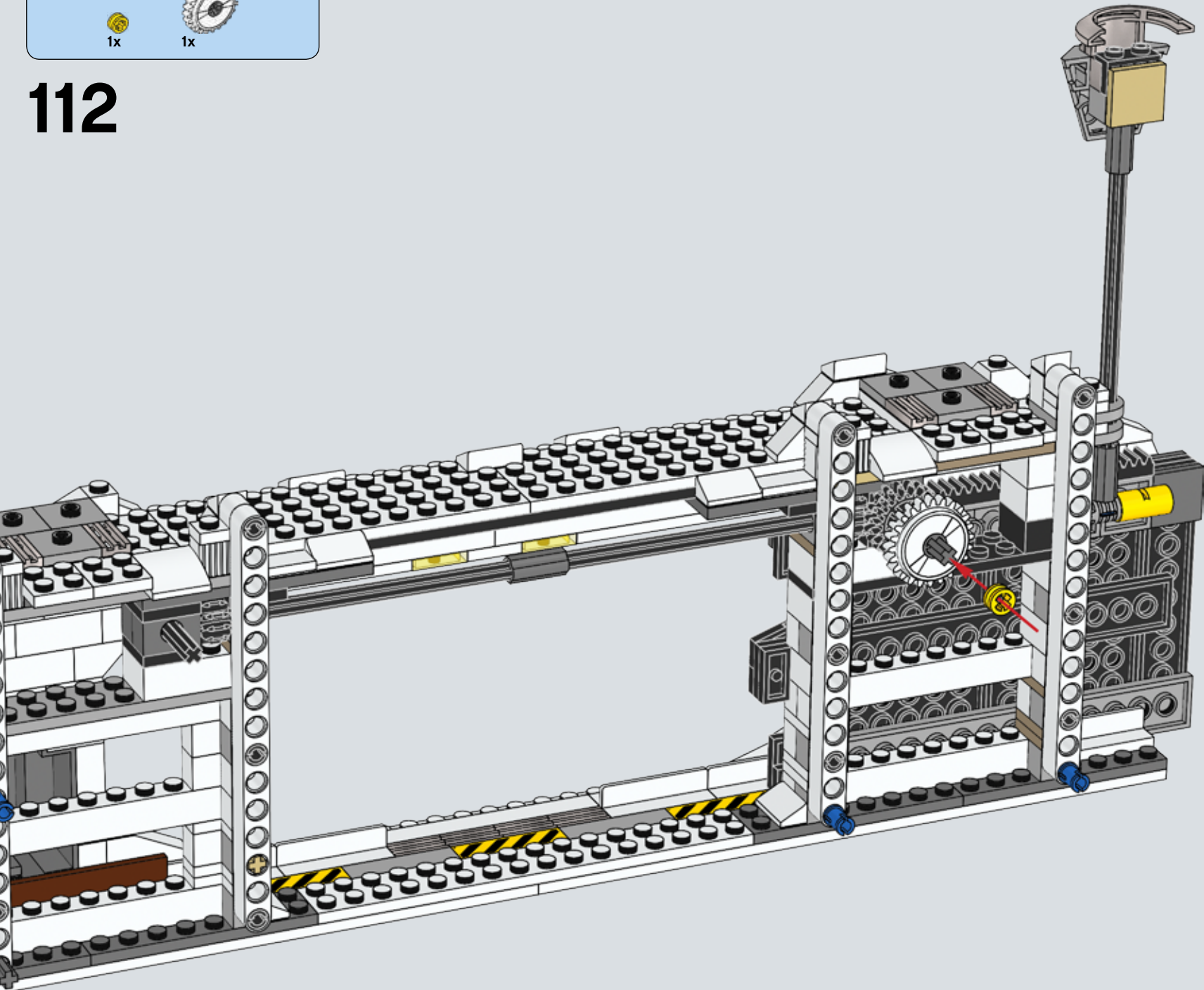



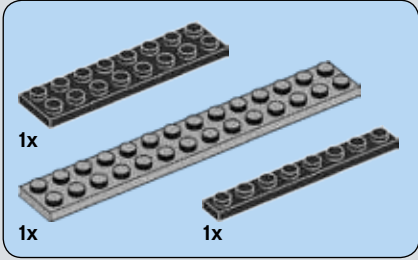
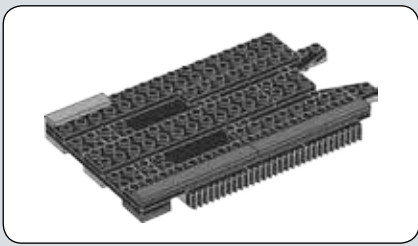

**113**

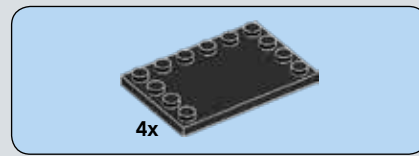
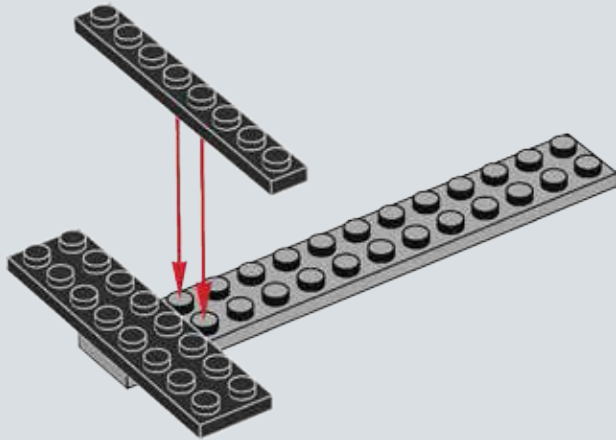

**114**

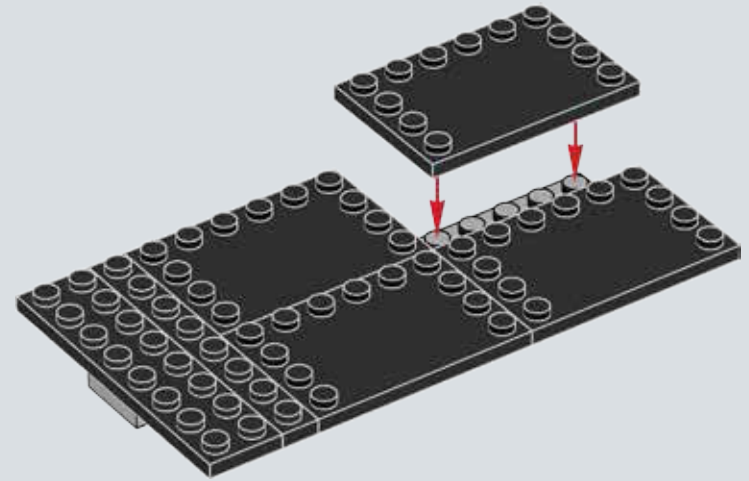

**115**

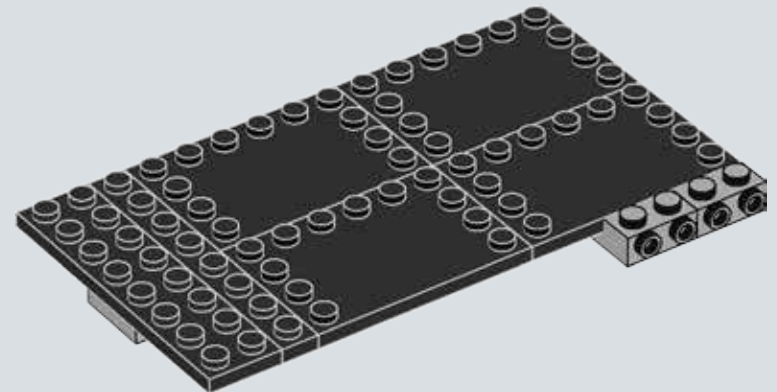

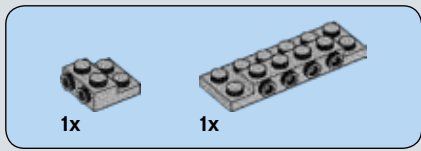

# 116

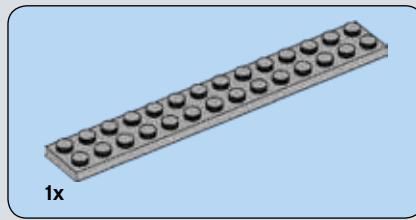
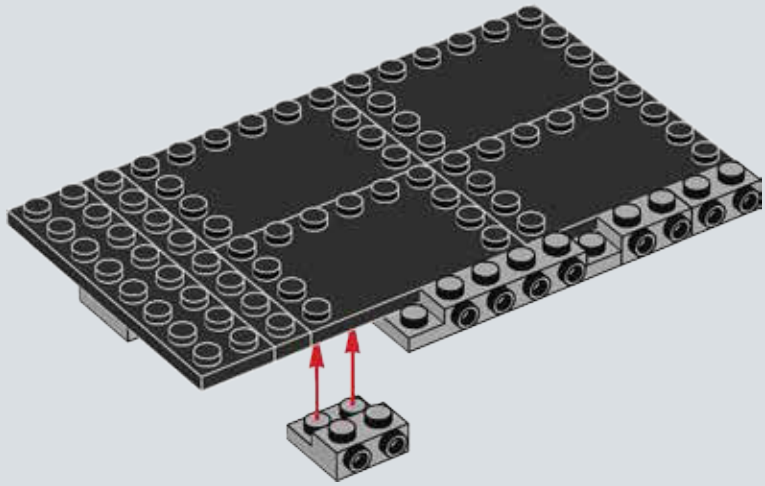

# 117

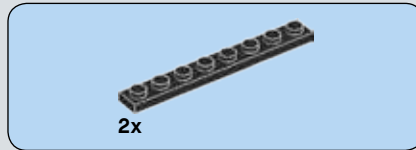
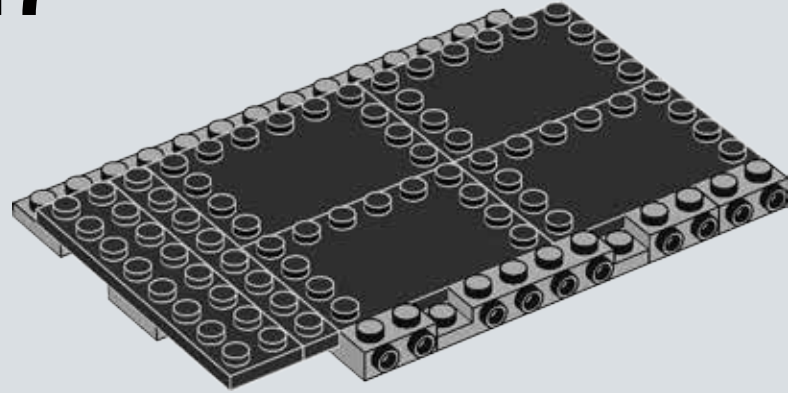

# 118

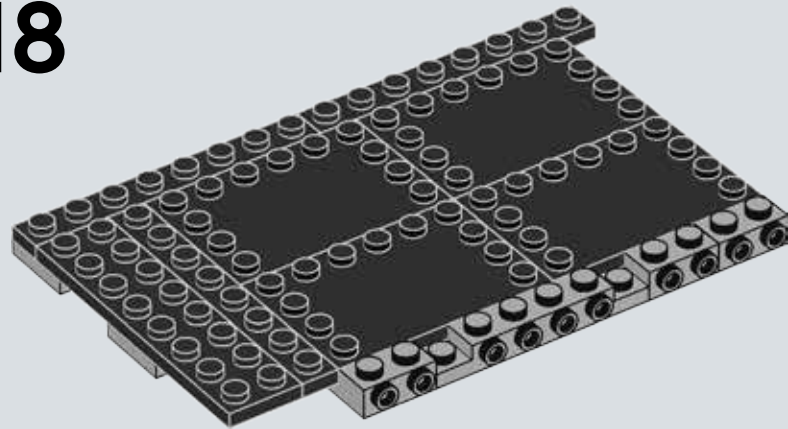



# 119

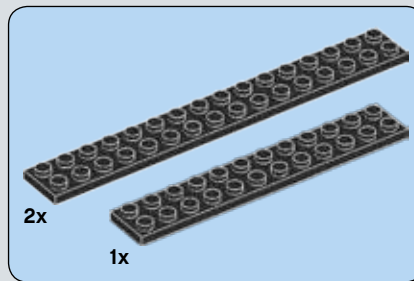
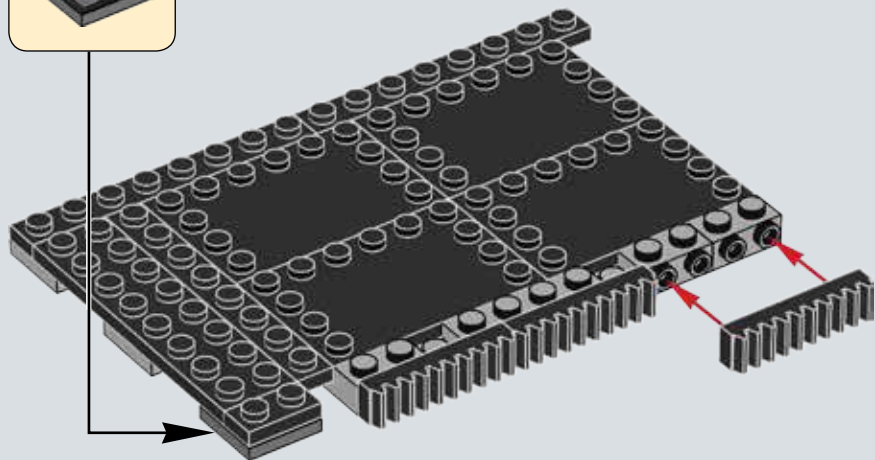
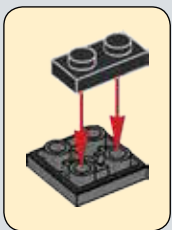

# 120

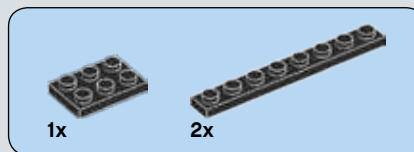
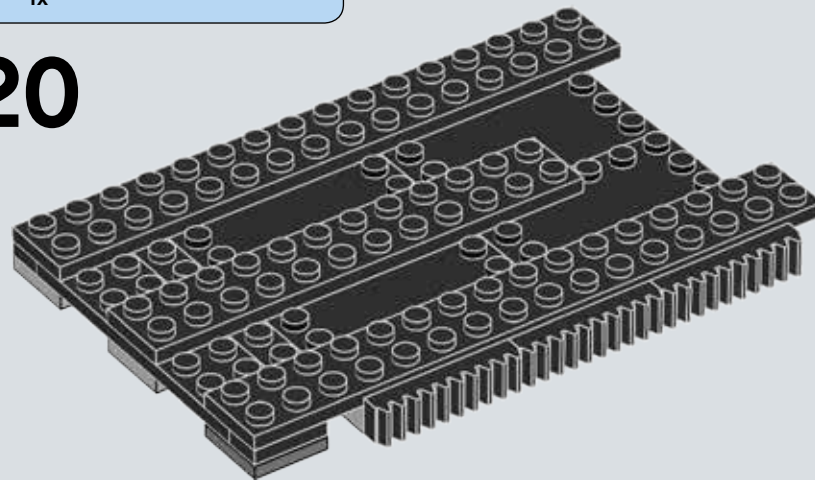

# 121

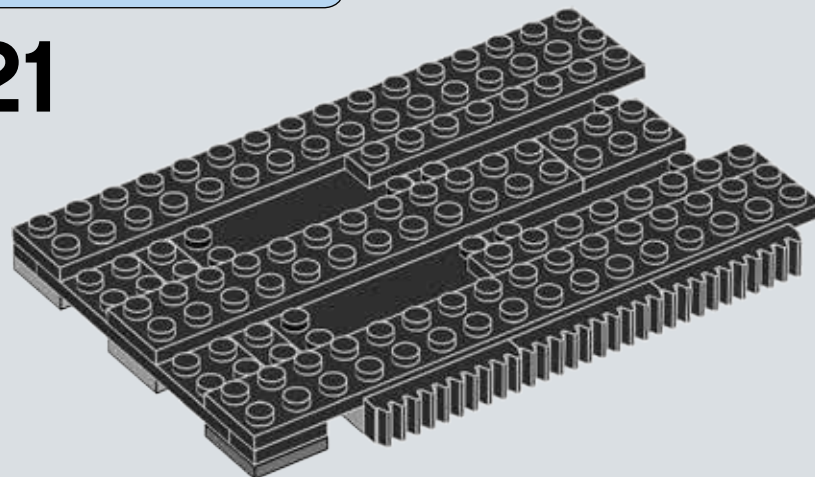

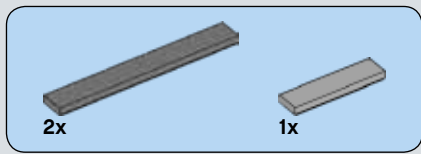

# 122

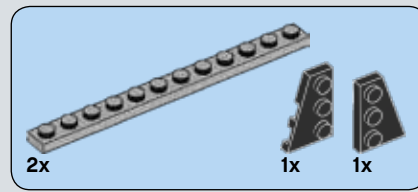
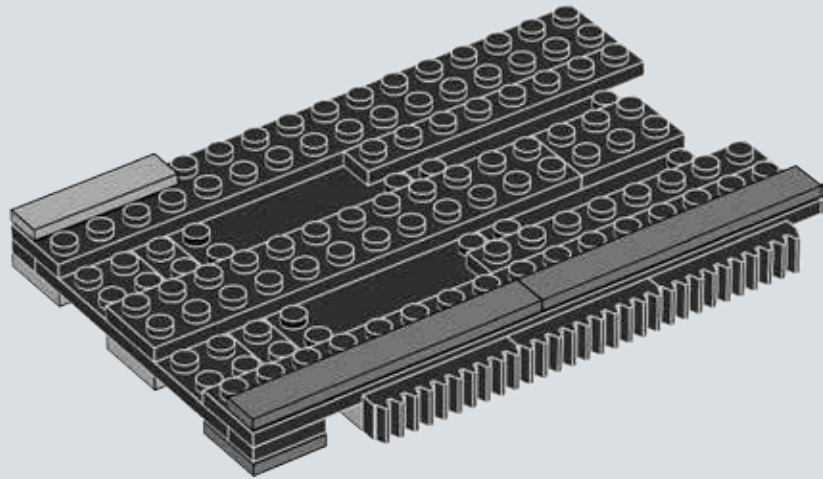

# 123

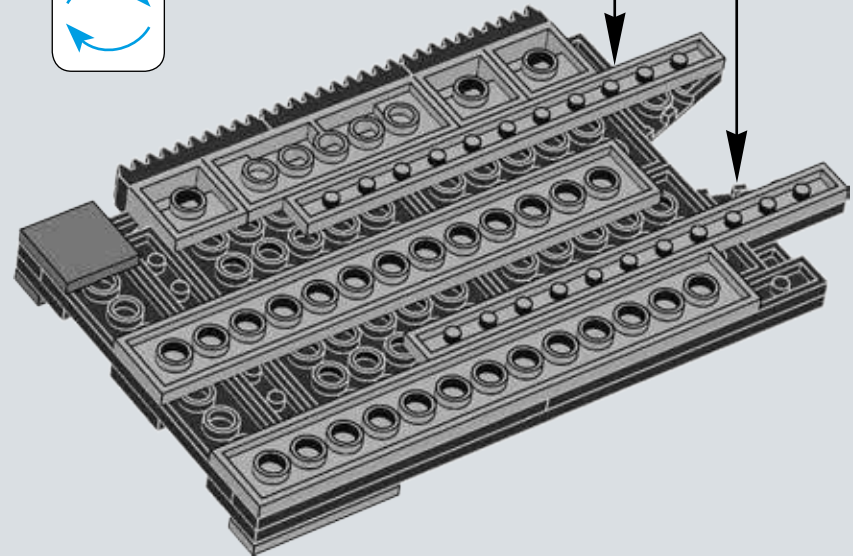
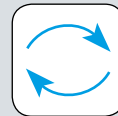
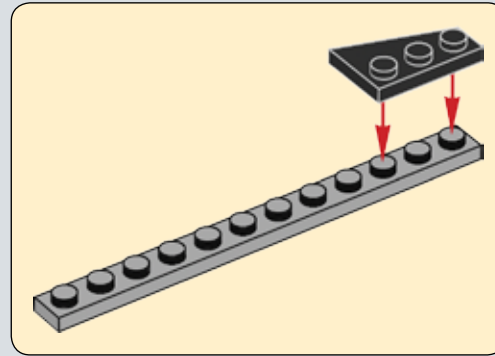
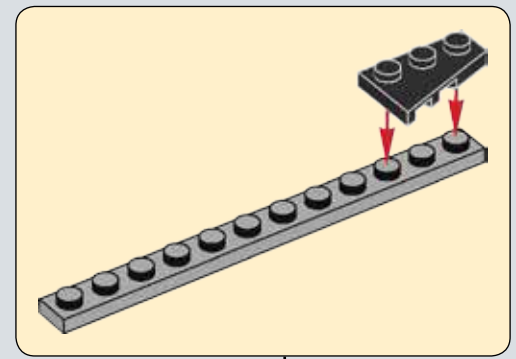



# 124

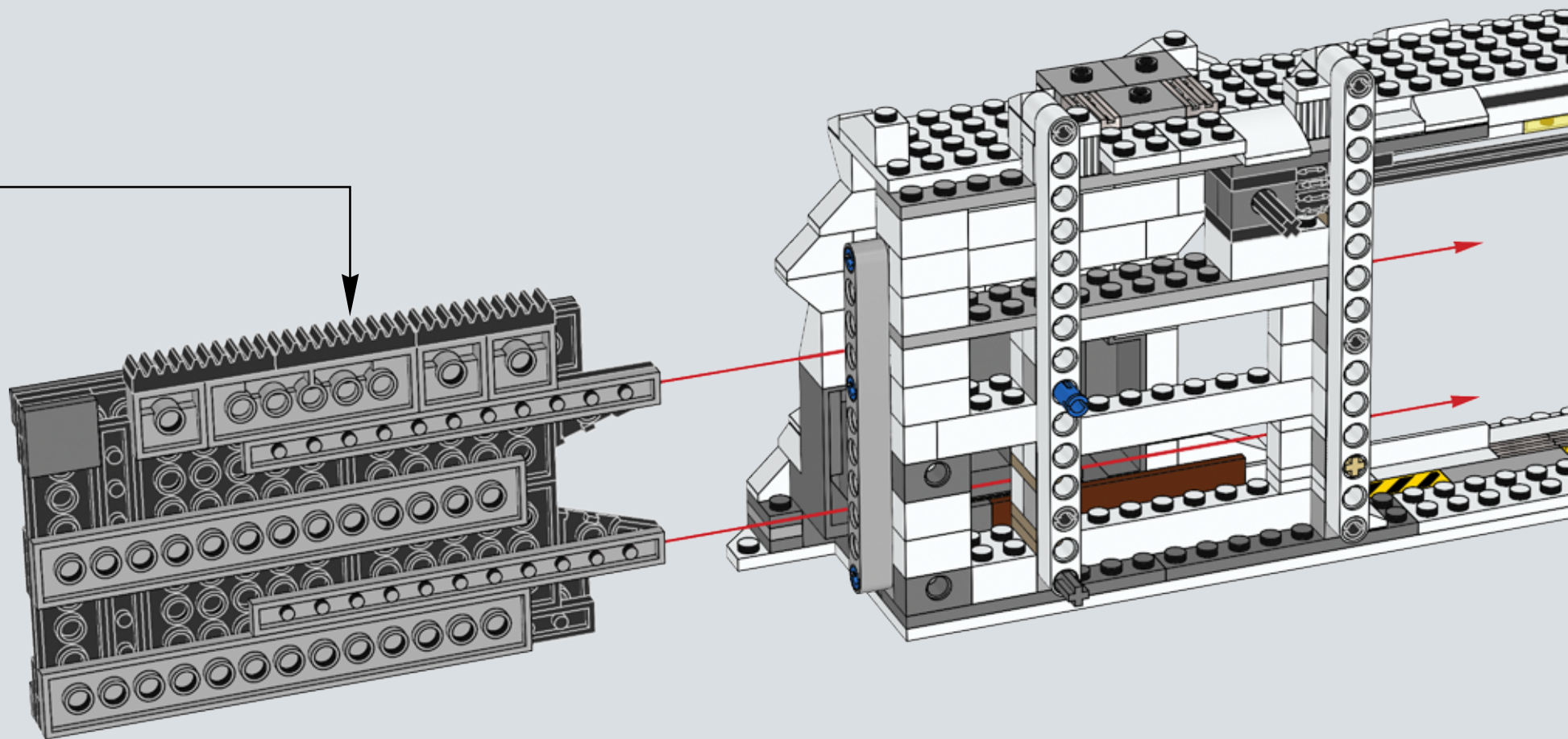



2x

# 125

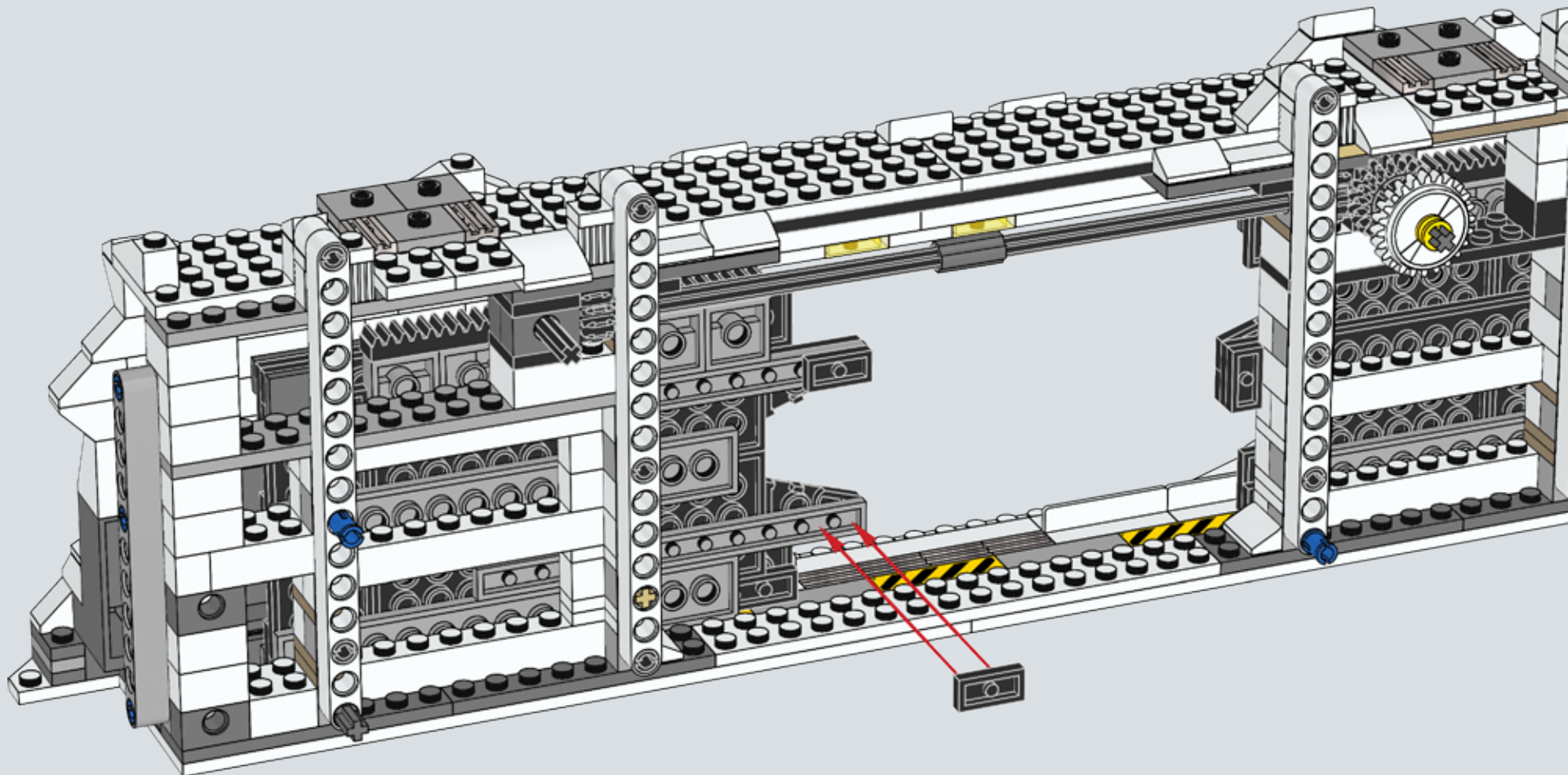



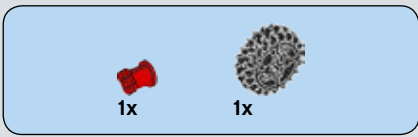

126

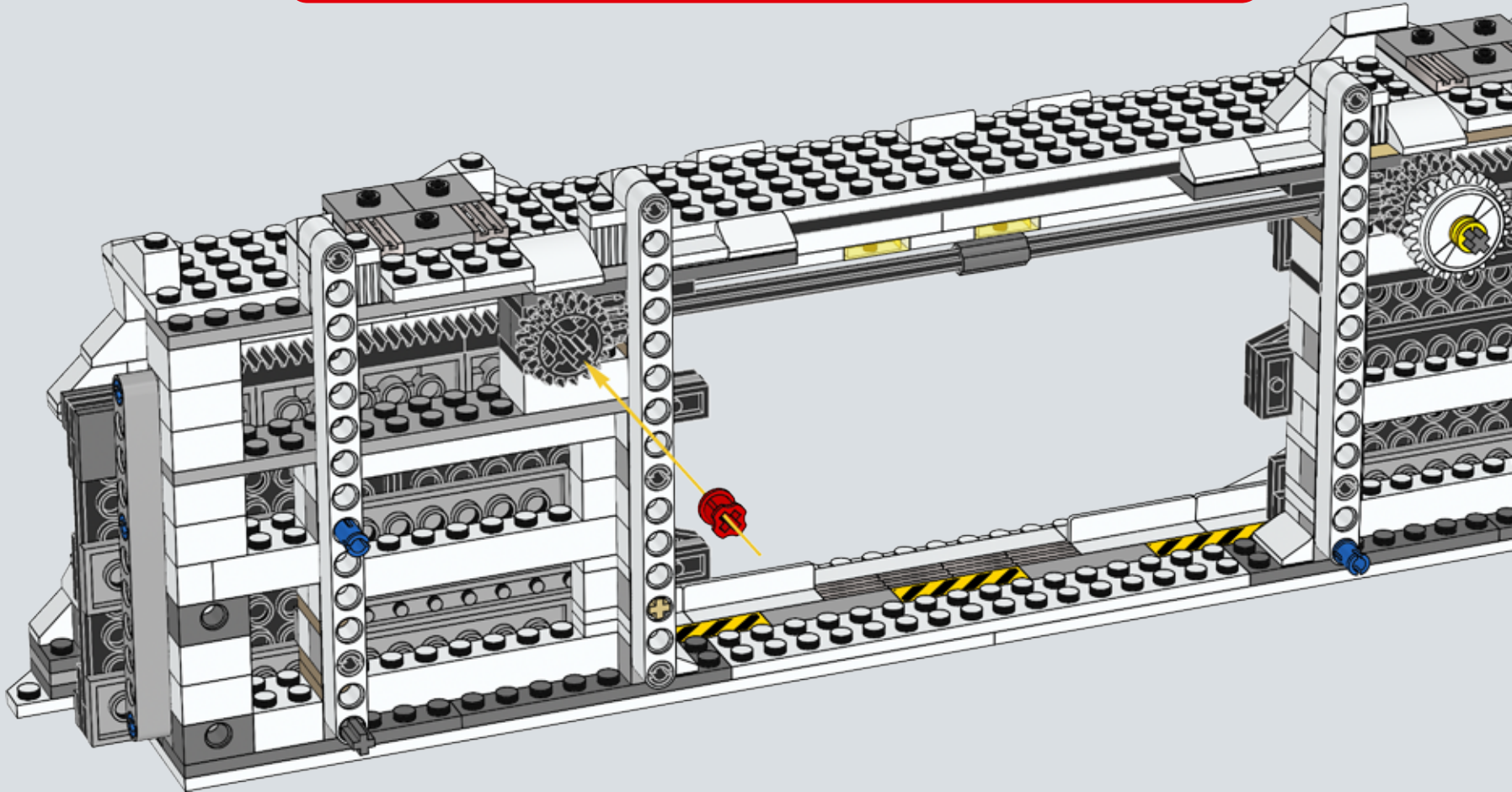
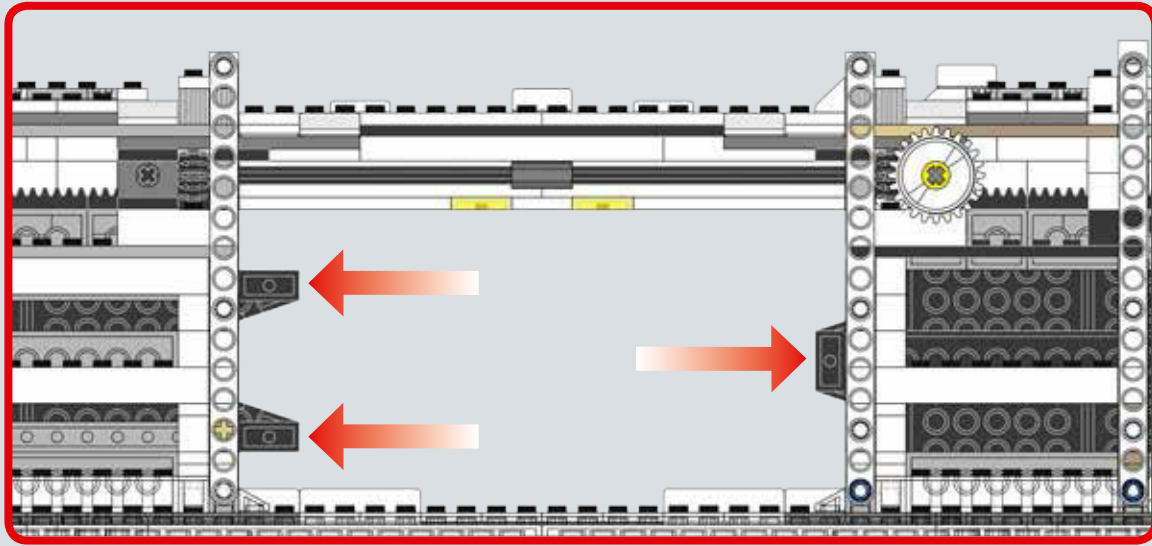

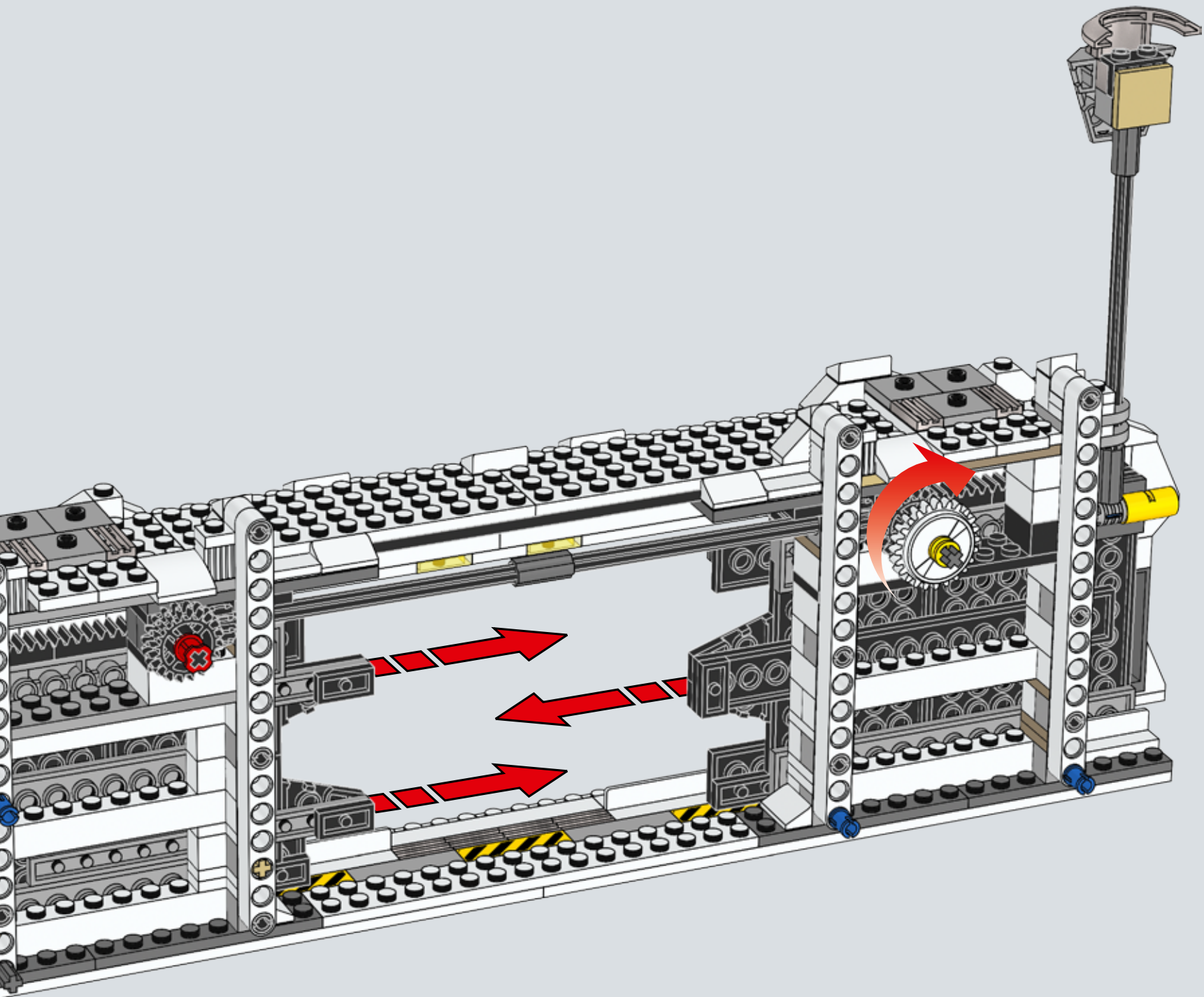



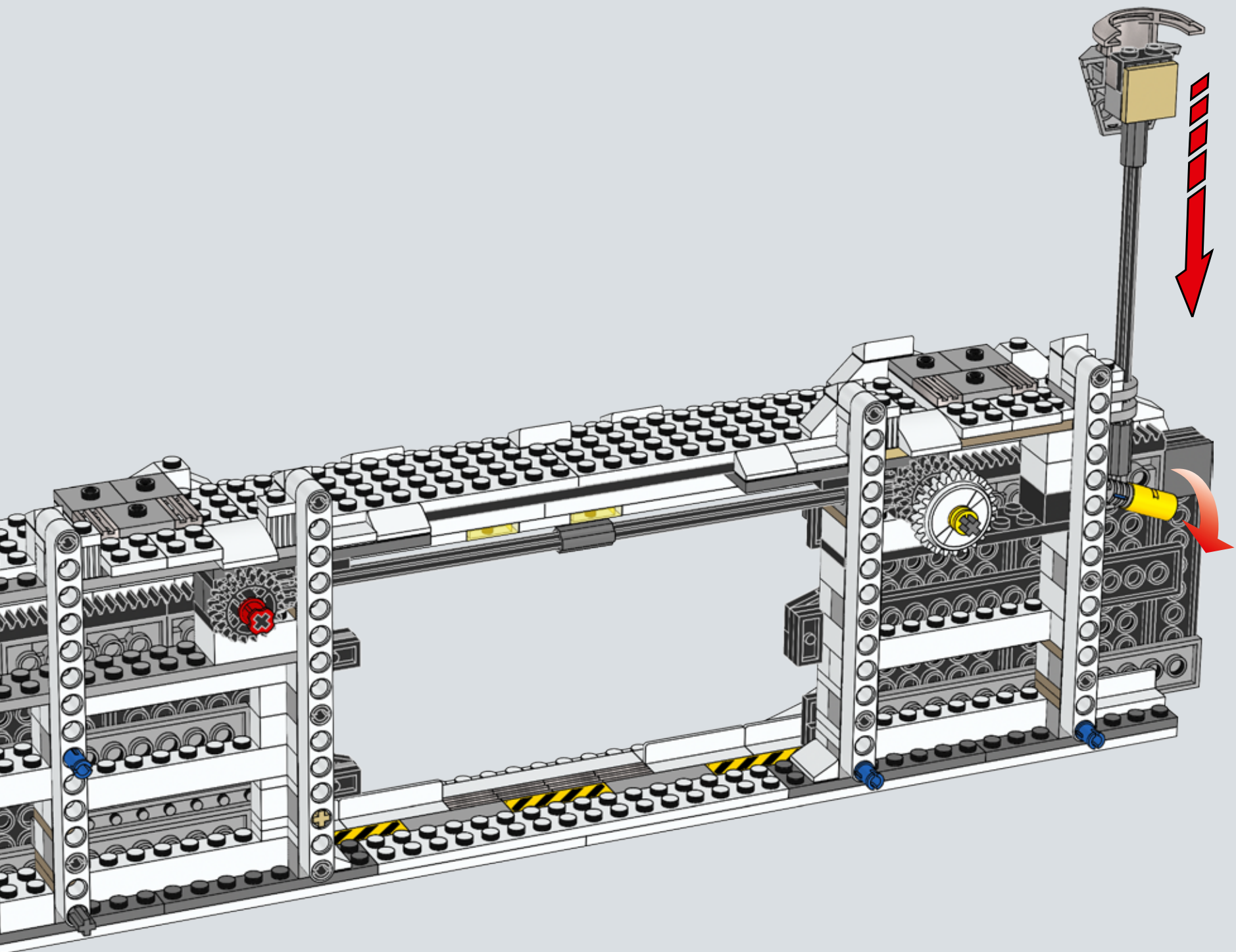

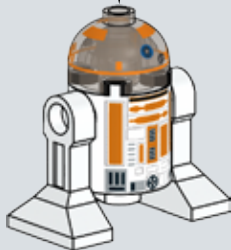
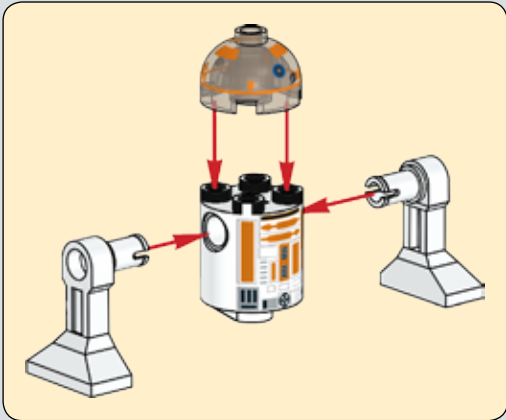
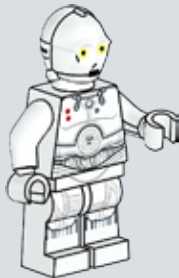
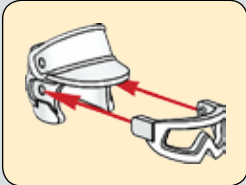
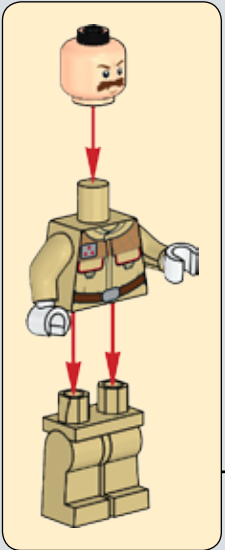
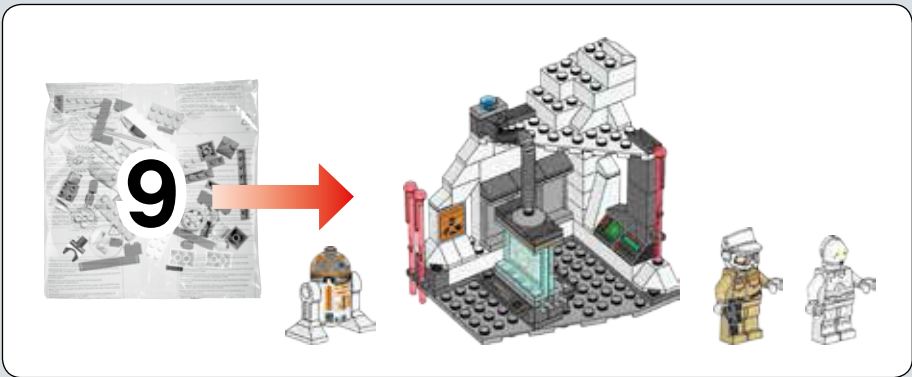

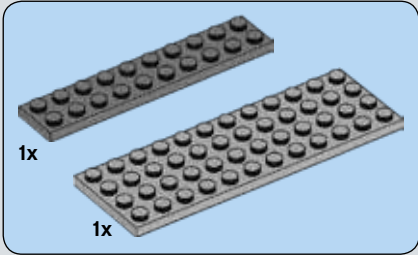
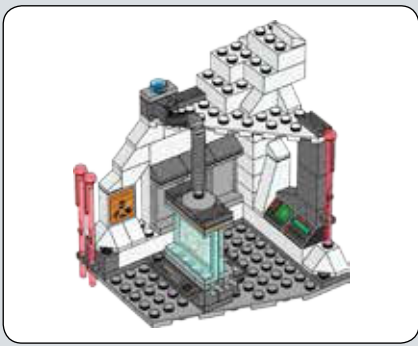

127

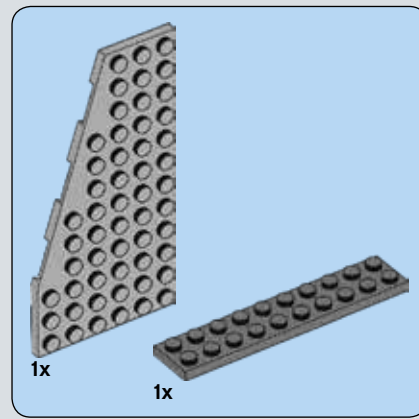
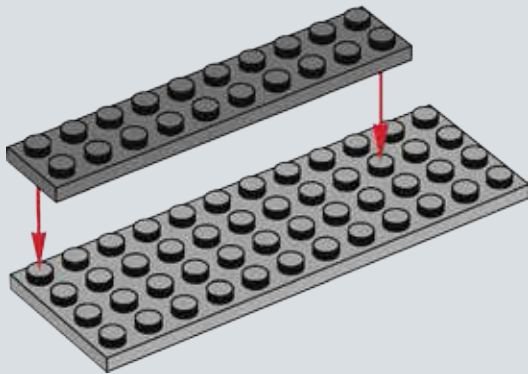

128

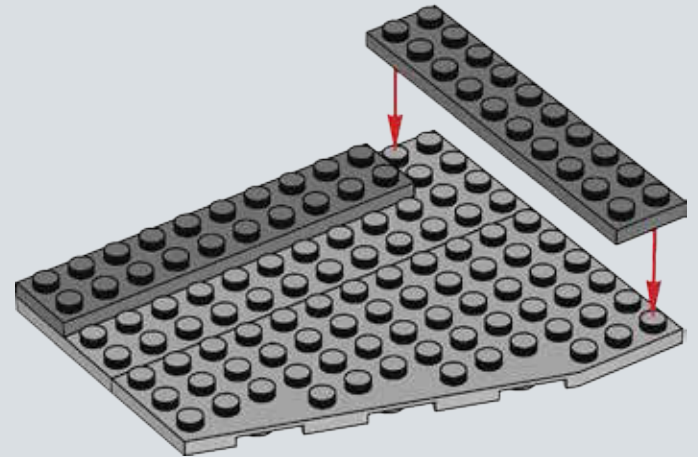

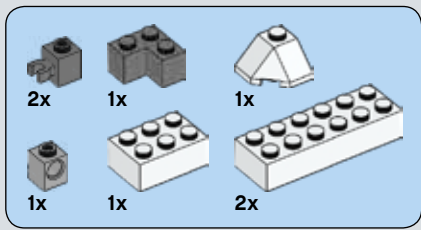

# 129

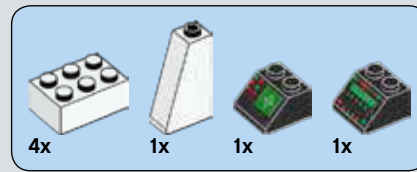
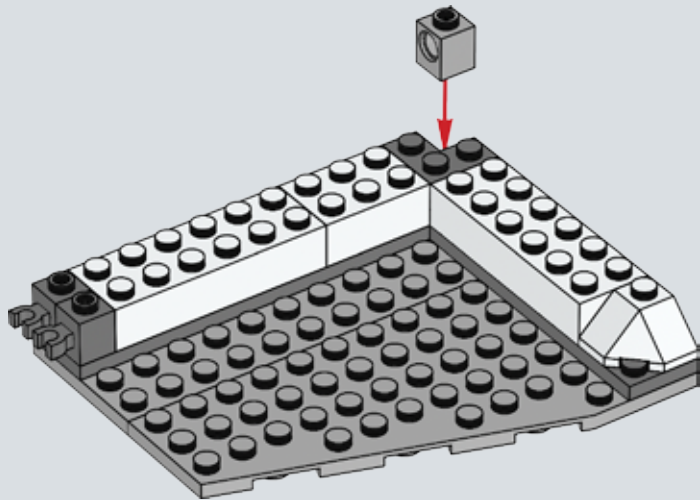

# 130

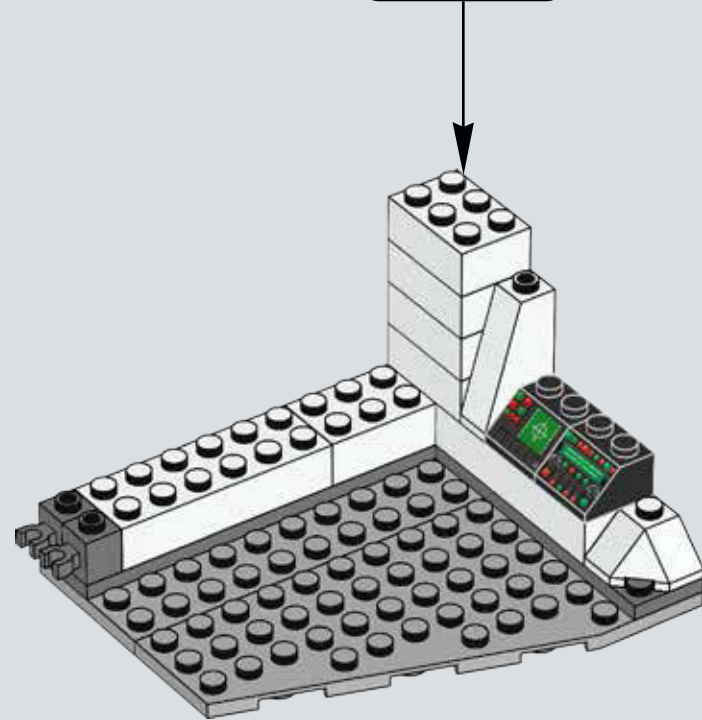
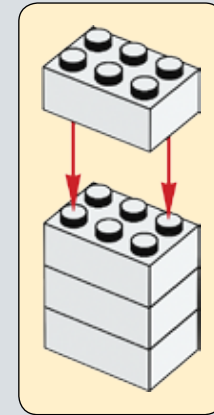





# 131

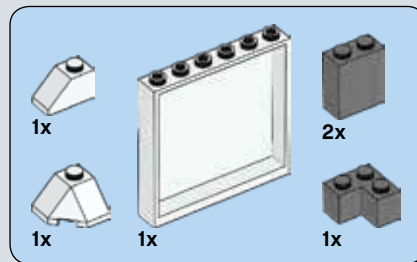
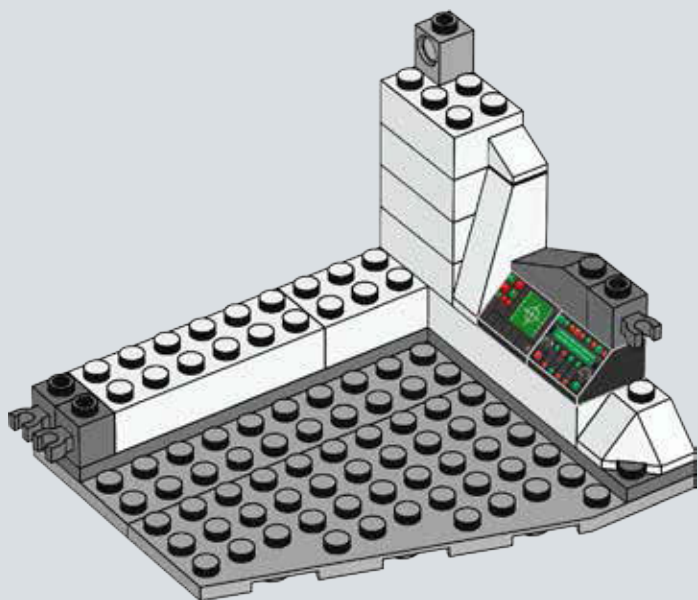

# 132

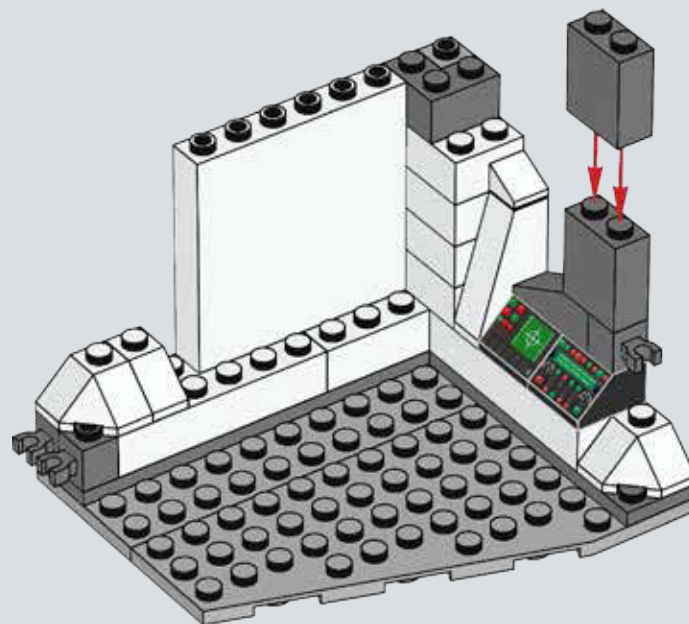

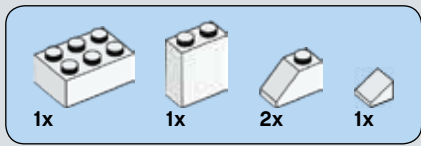

# 133

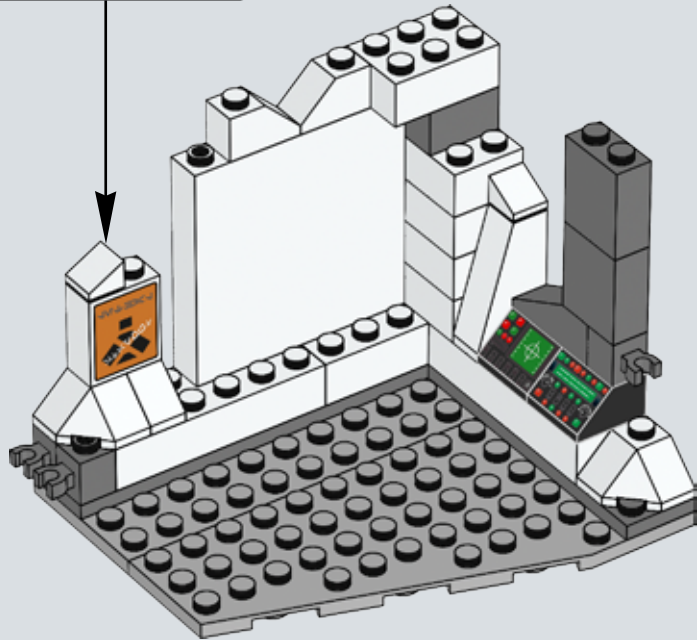
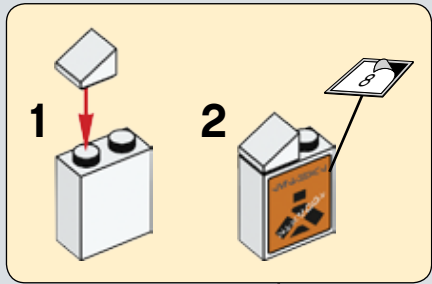

# 134

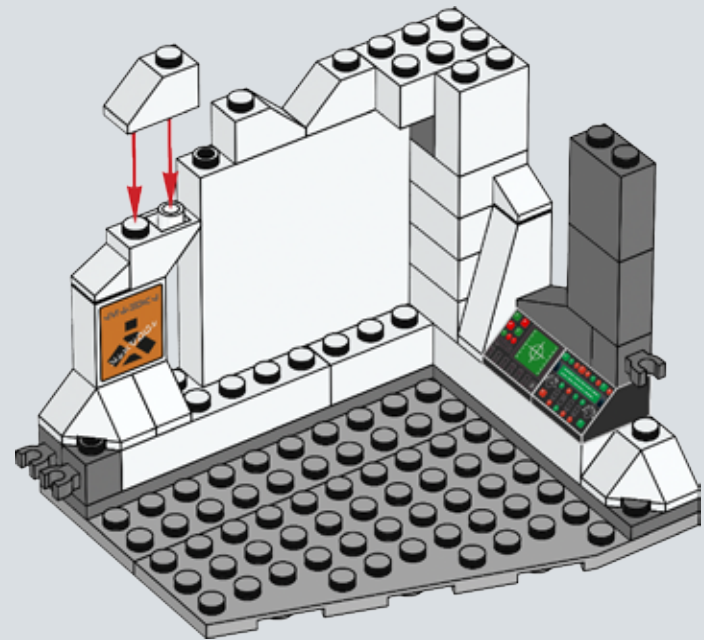



# 135

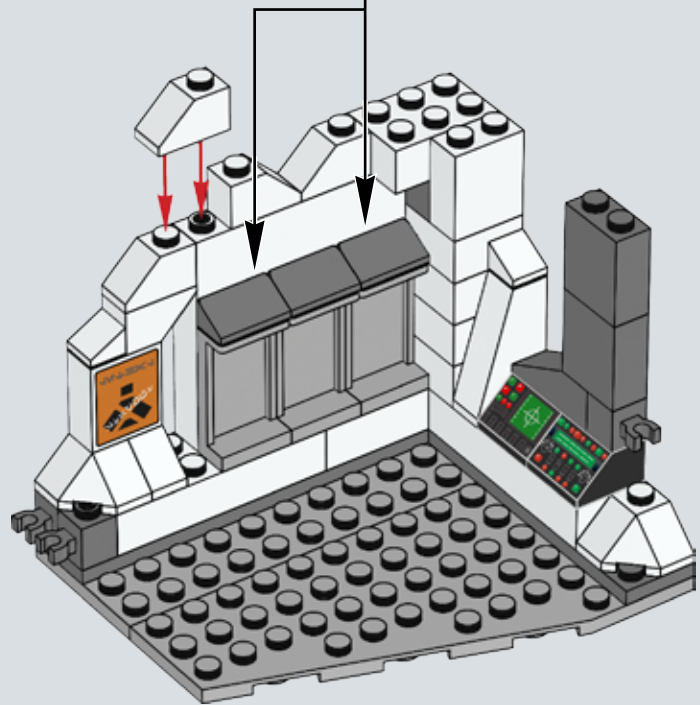
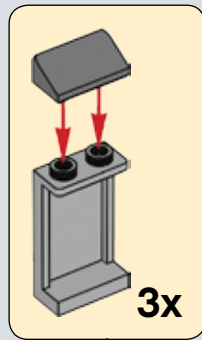

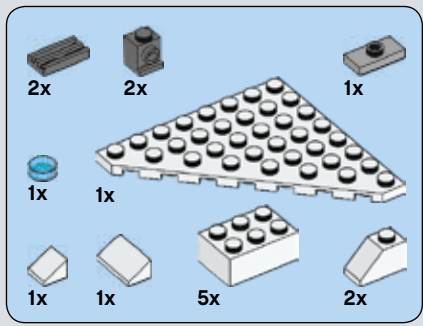

# 136

1

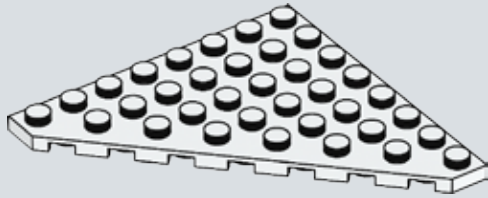

2

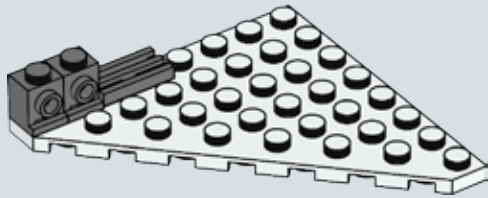

3

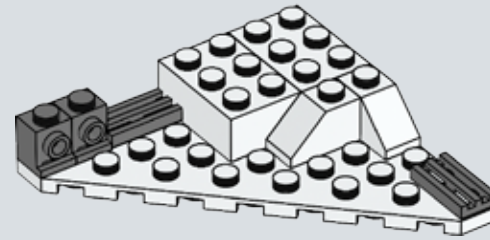

4

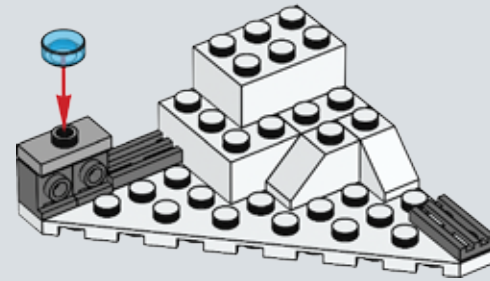



5

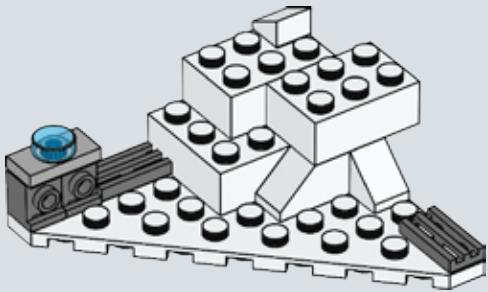

6

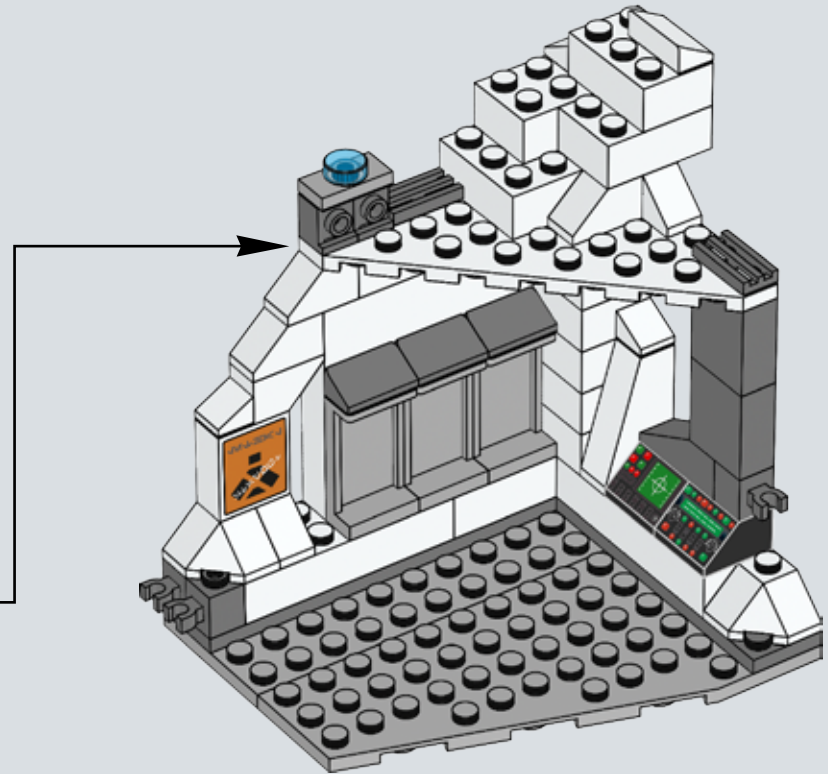
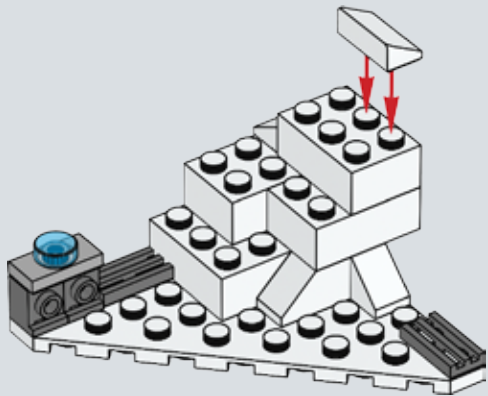

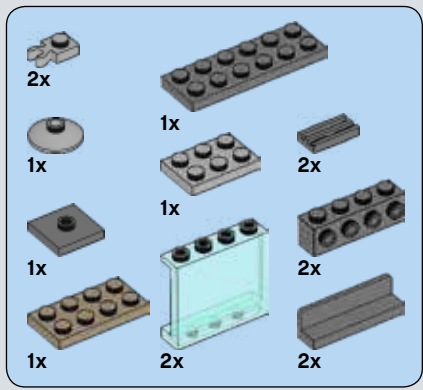

# 137

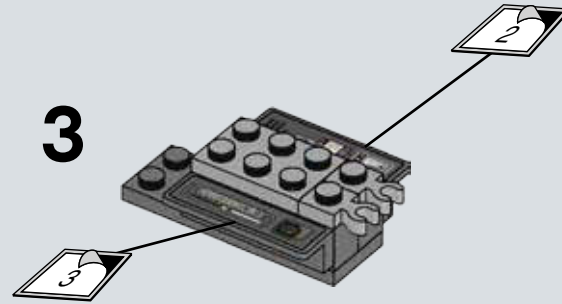
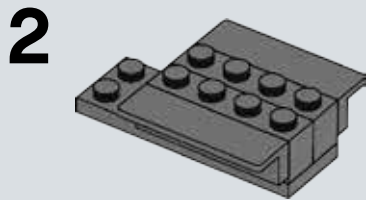
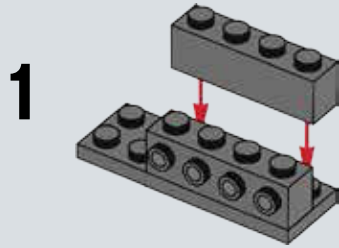

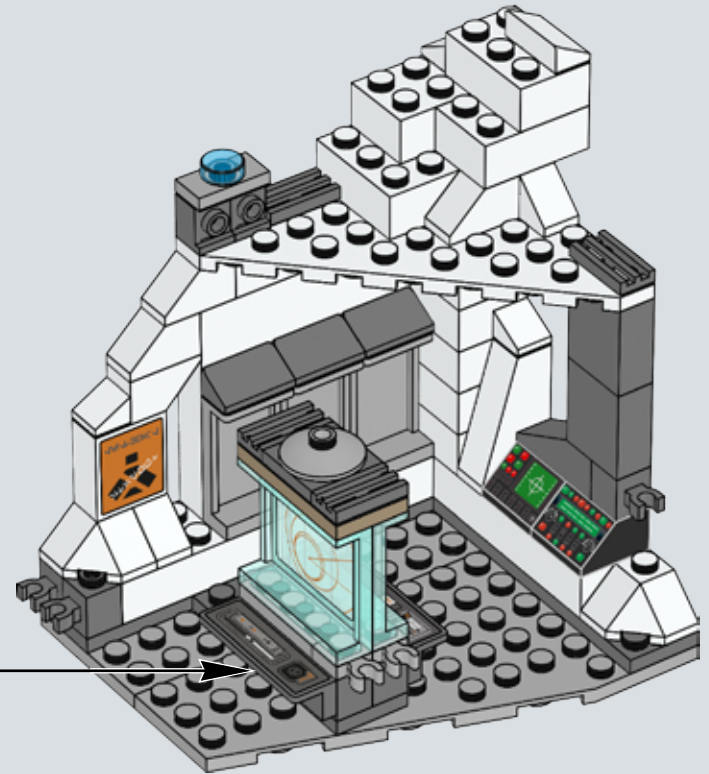
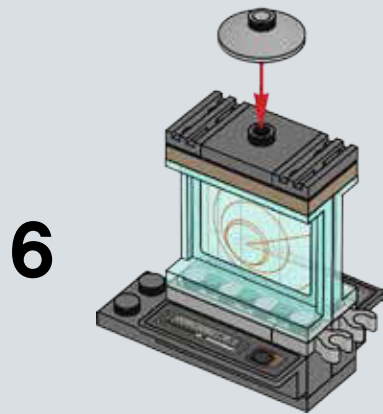
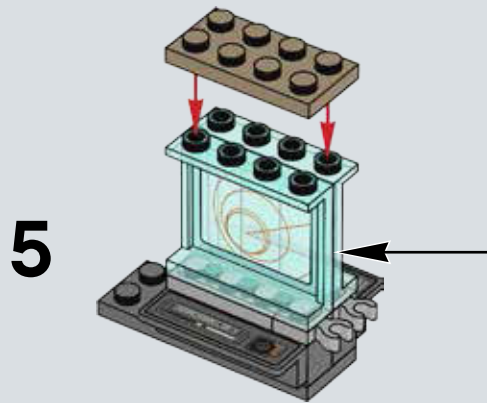
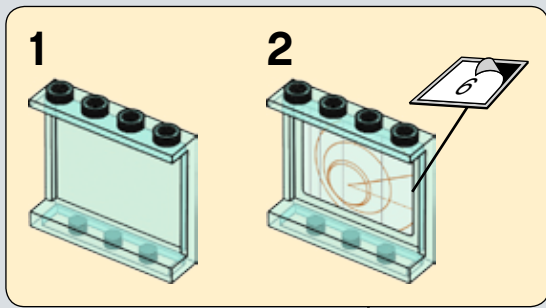

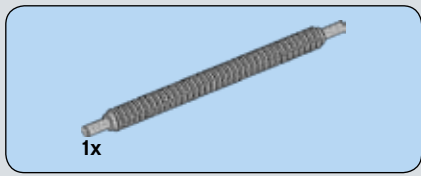

# 138

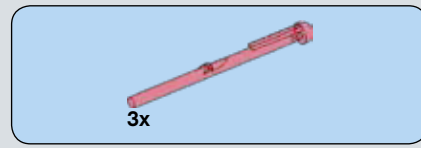
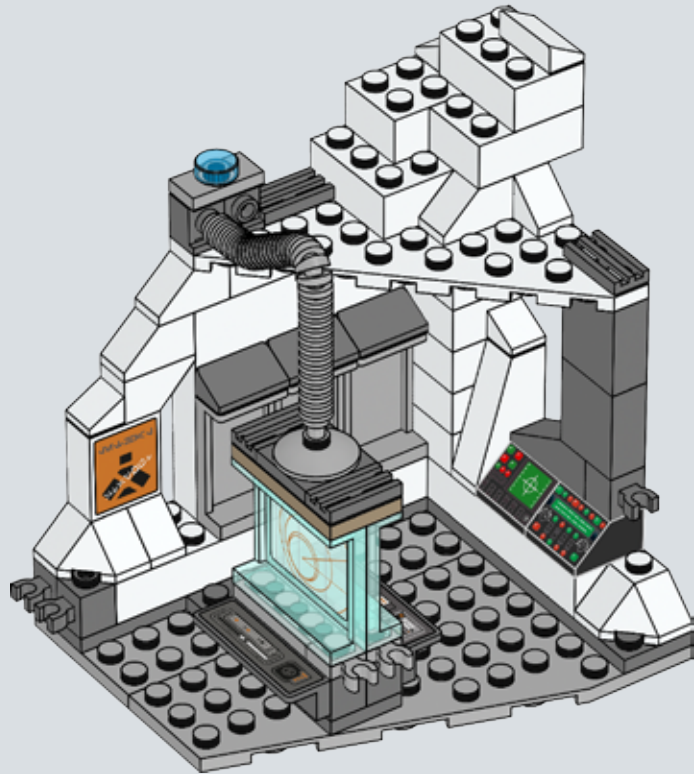

# 139

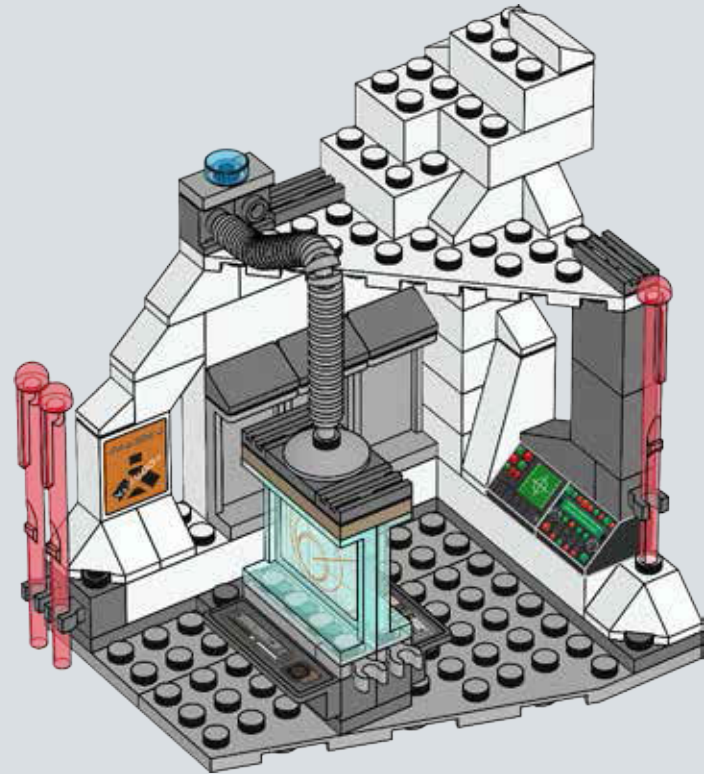



140

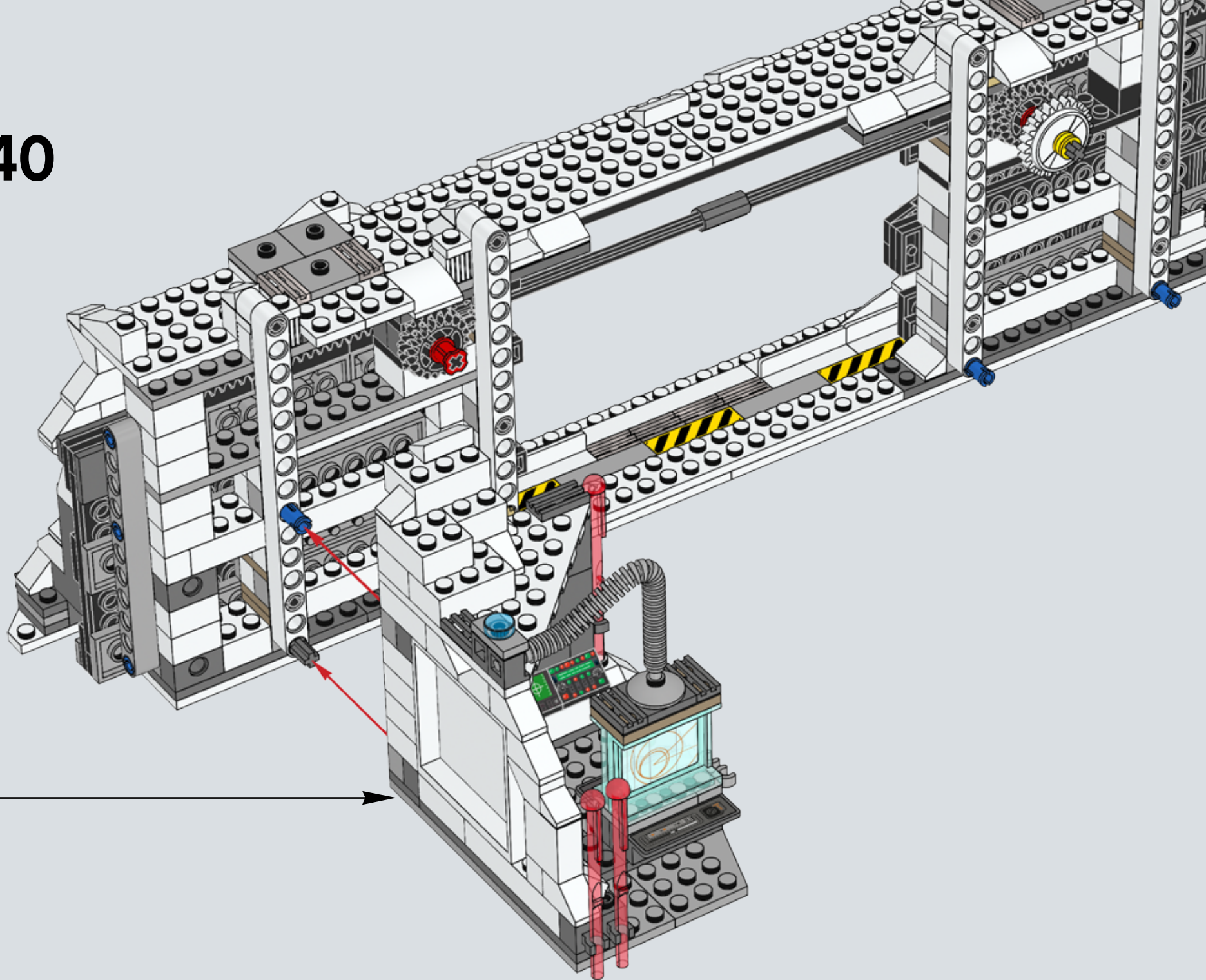

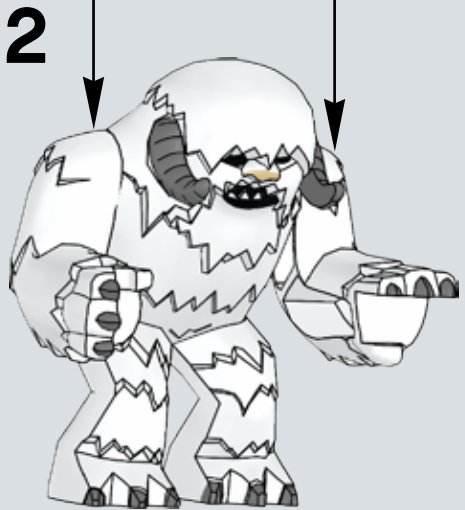
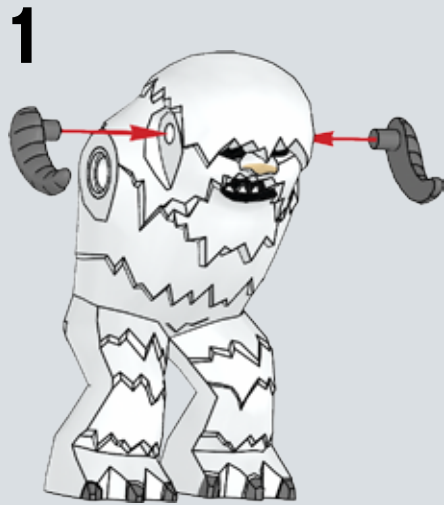
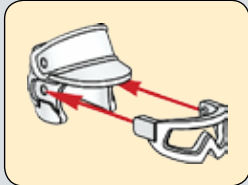
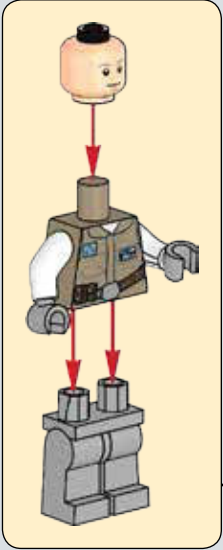
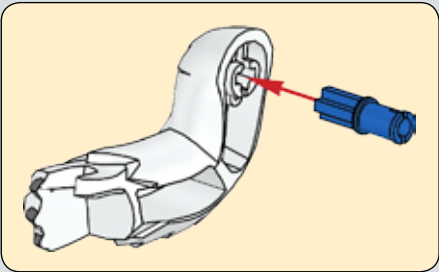
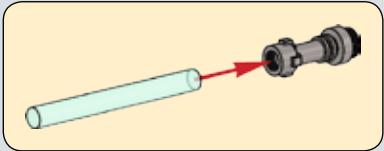
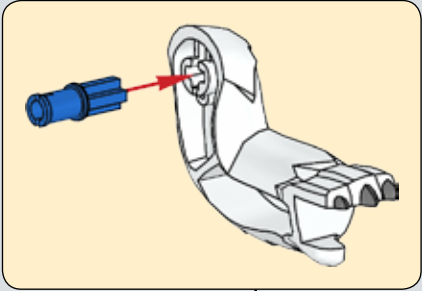
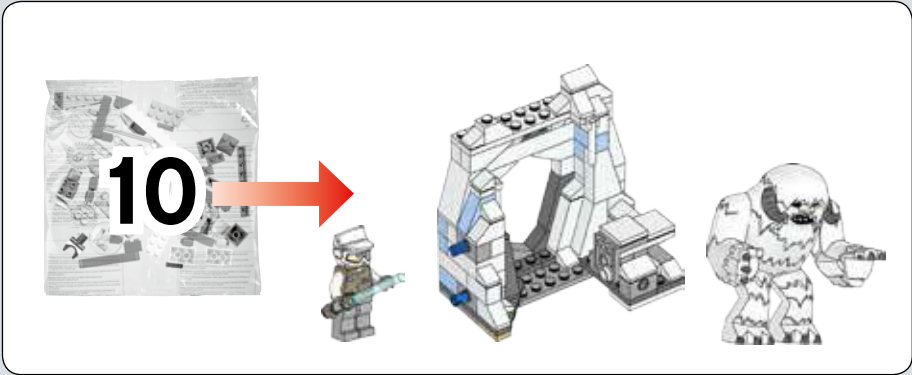

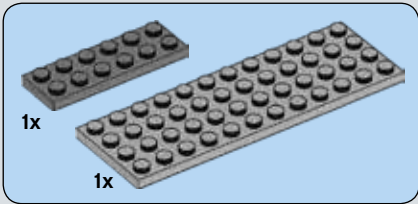
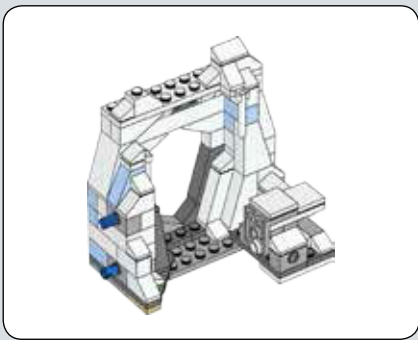

141

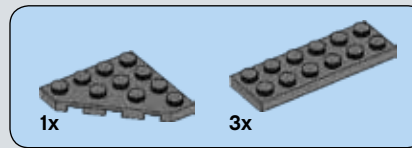
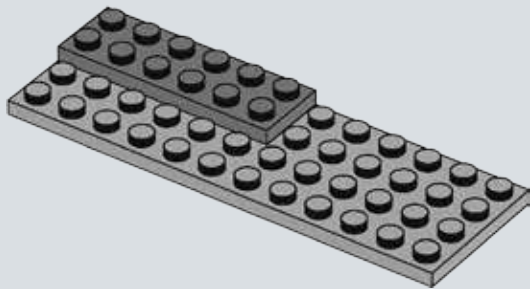

142

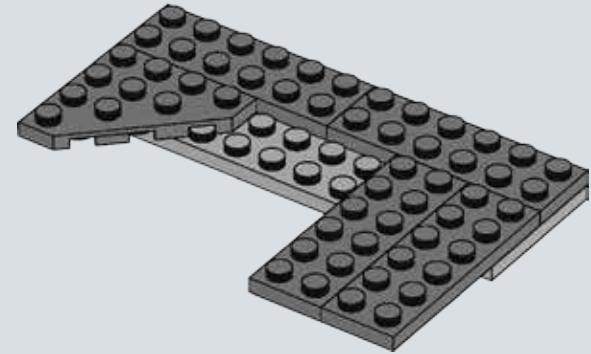

143

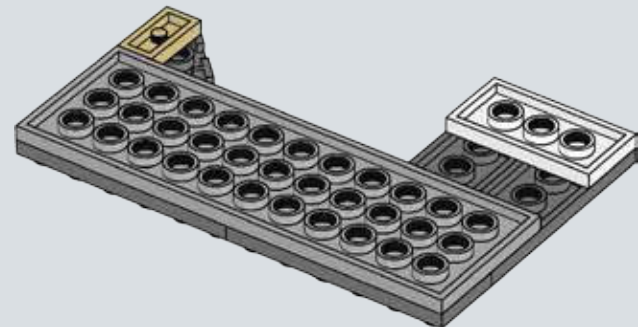
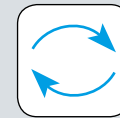

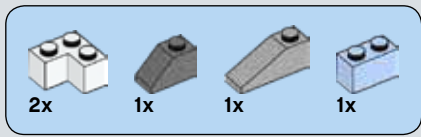

# 144

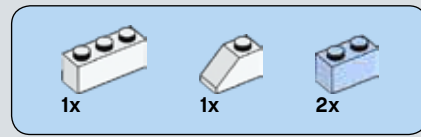
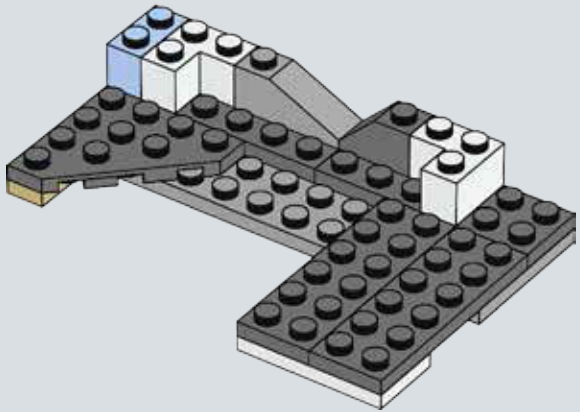
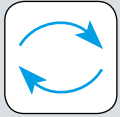

# 145

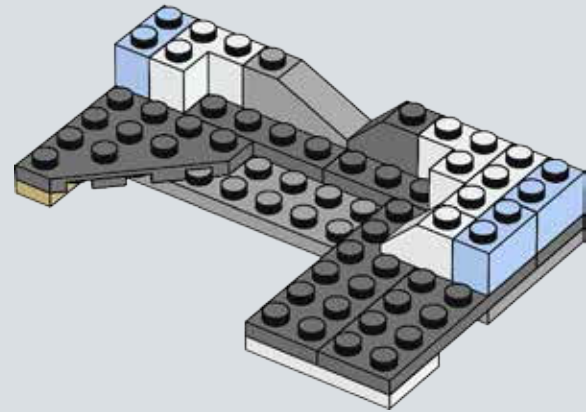



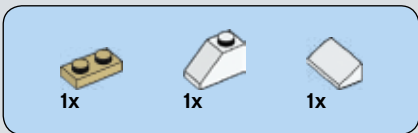

# 146

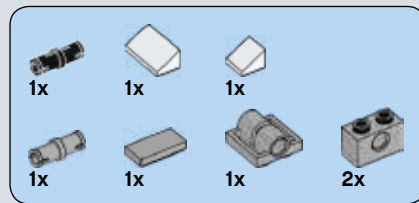
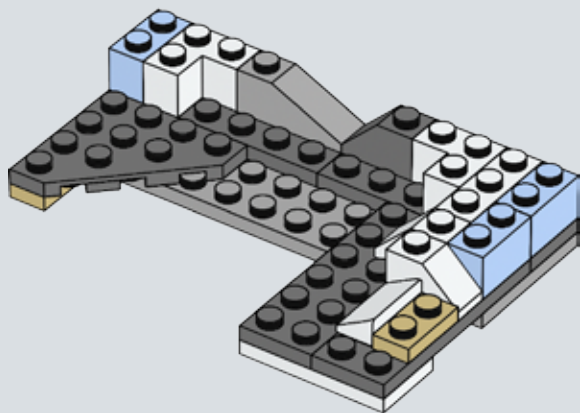

# 147

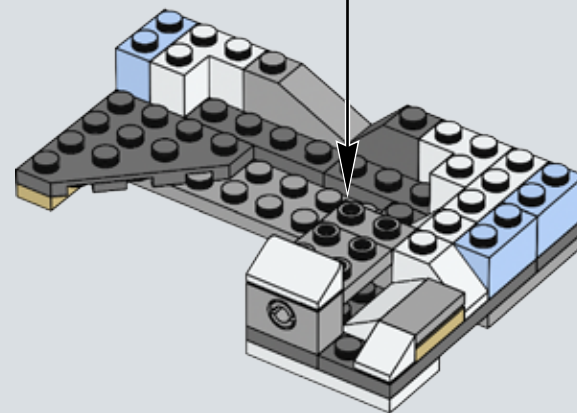
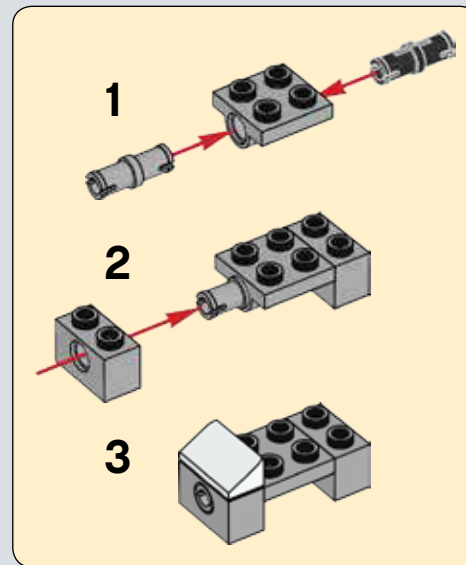

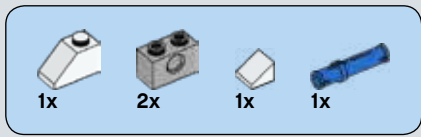

# 148

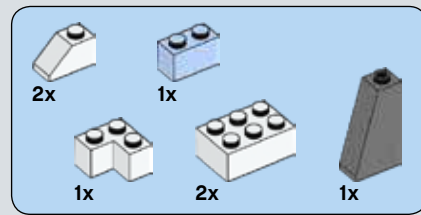
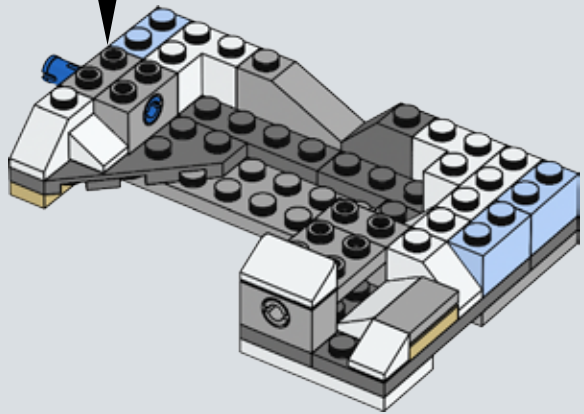
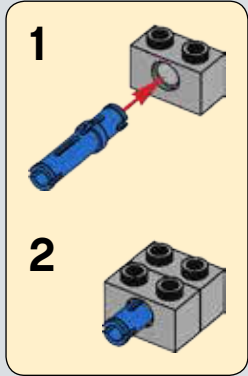

# 149

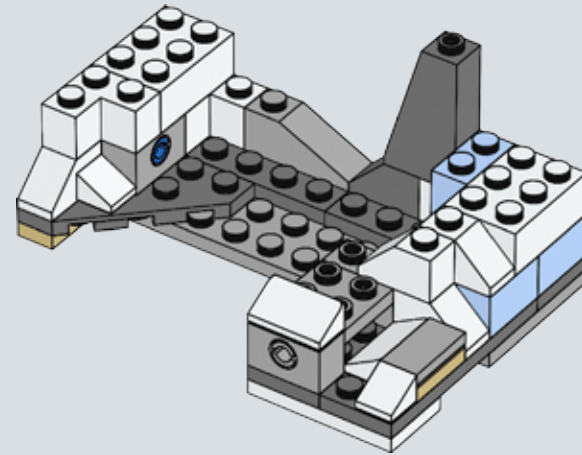

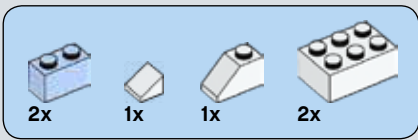

# 150

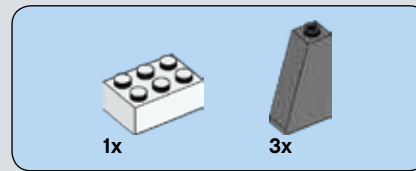
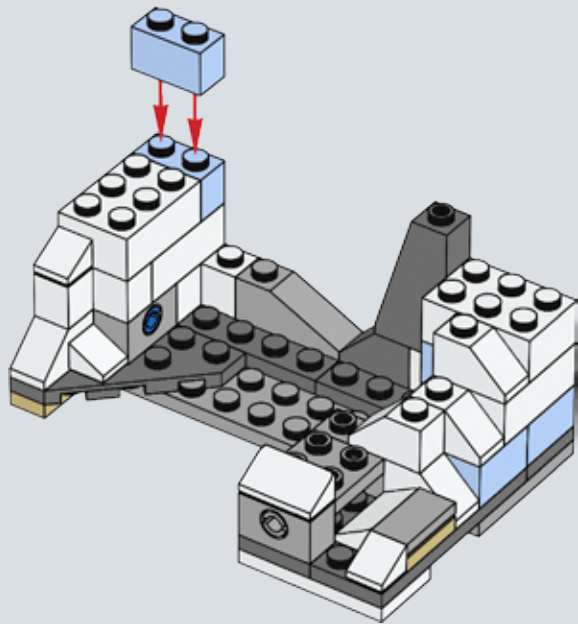

# 151

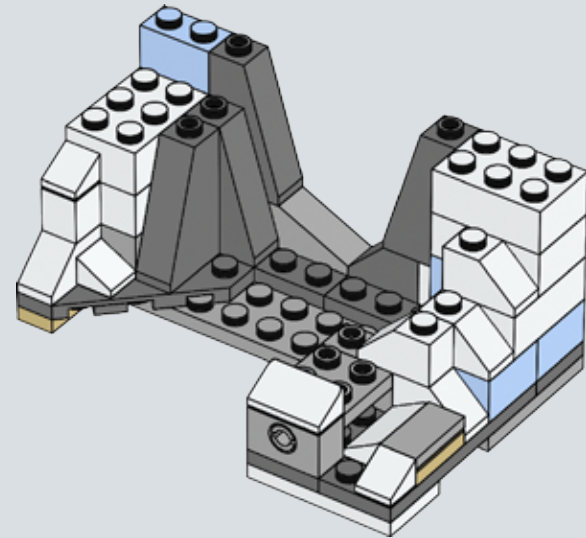

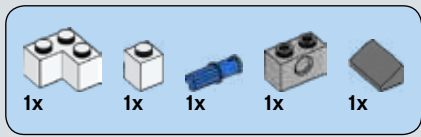

# 152

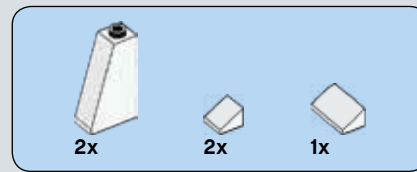
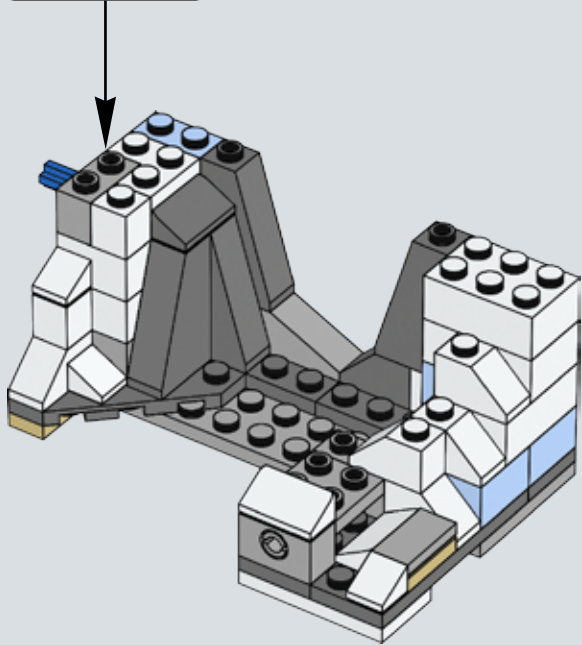
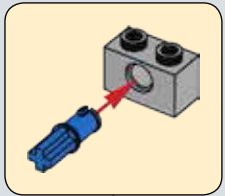

# 153

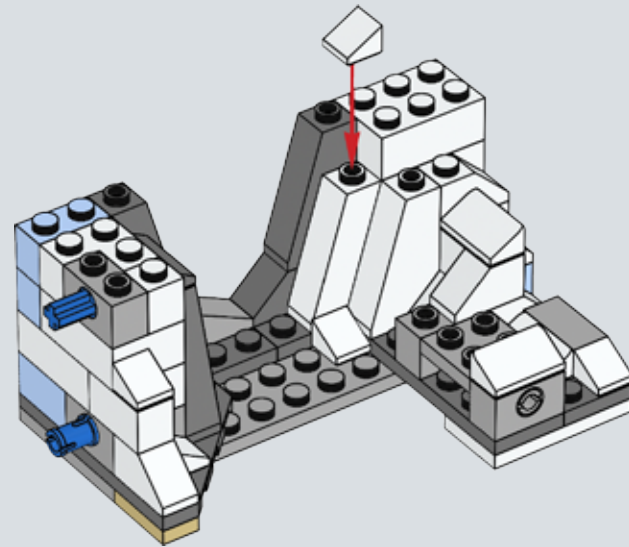



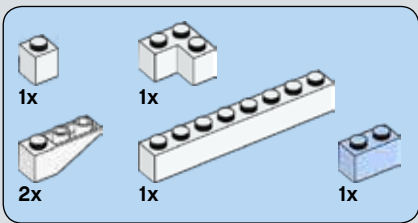

# 154

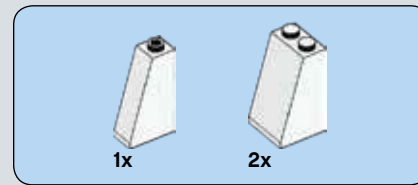
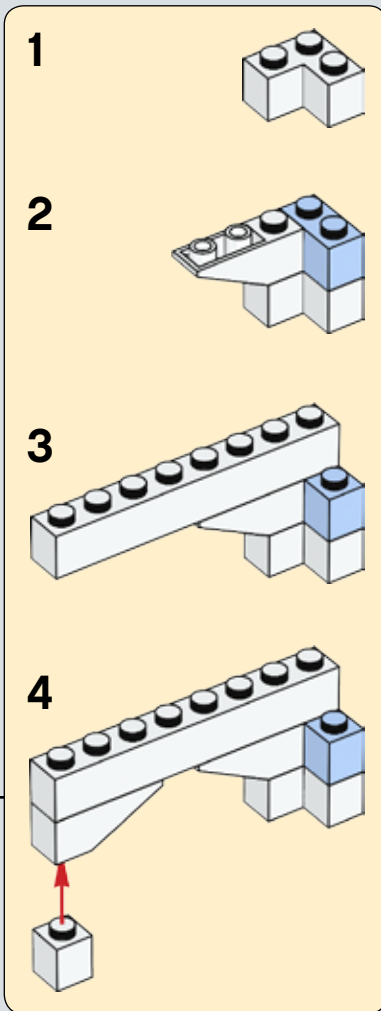
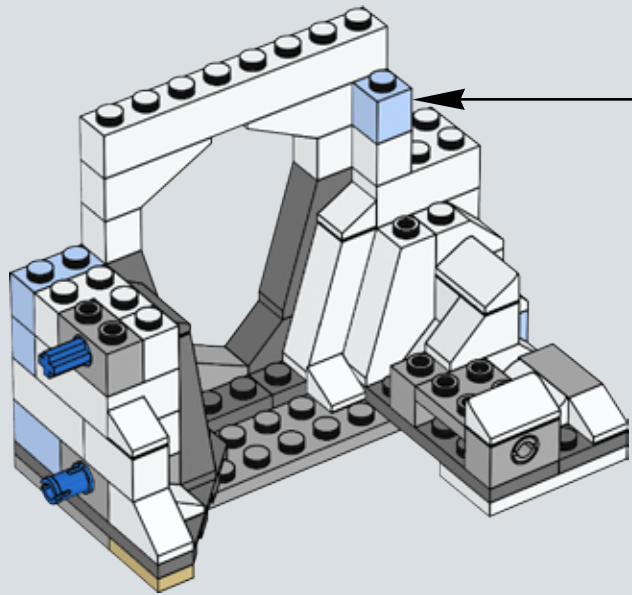

# 155

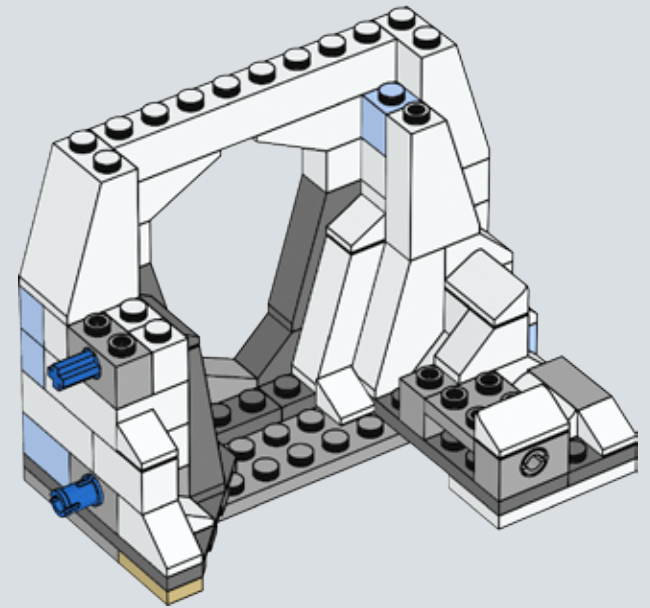

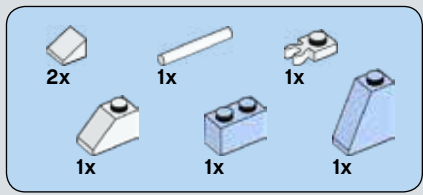

# 156

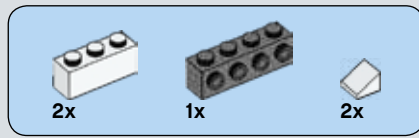
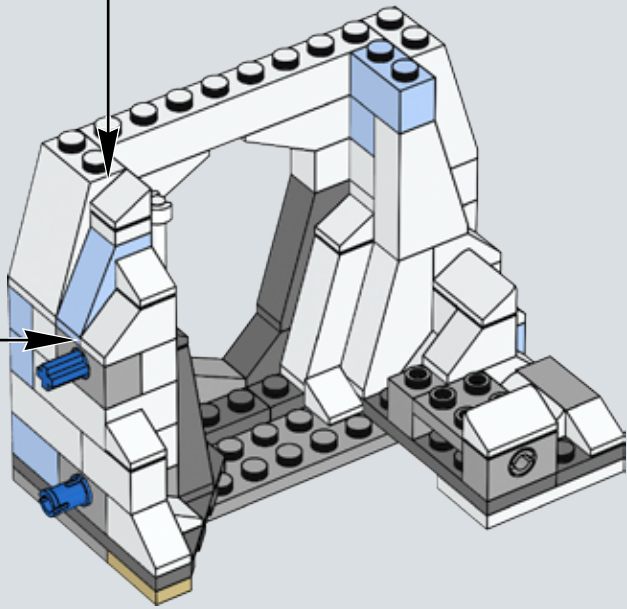
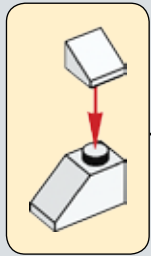
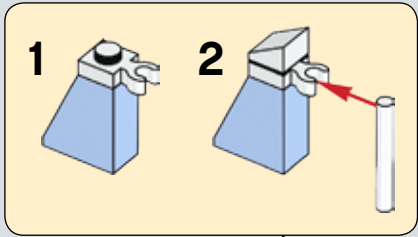

# 157

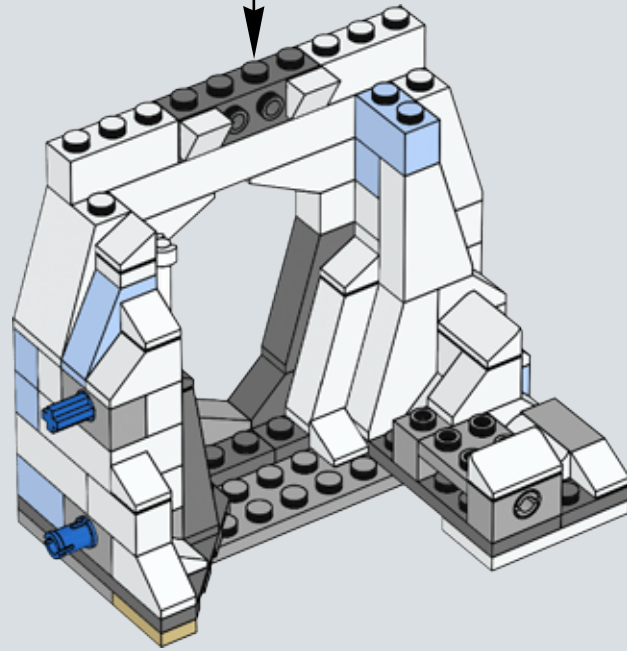
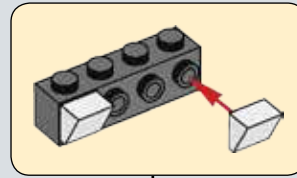

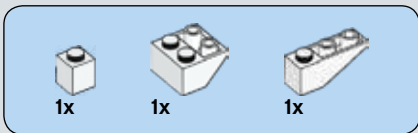

# 158

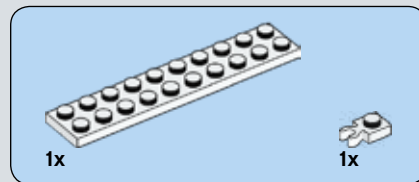
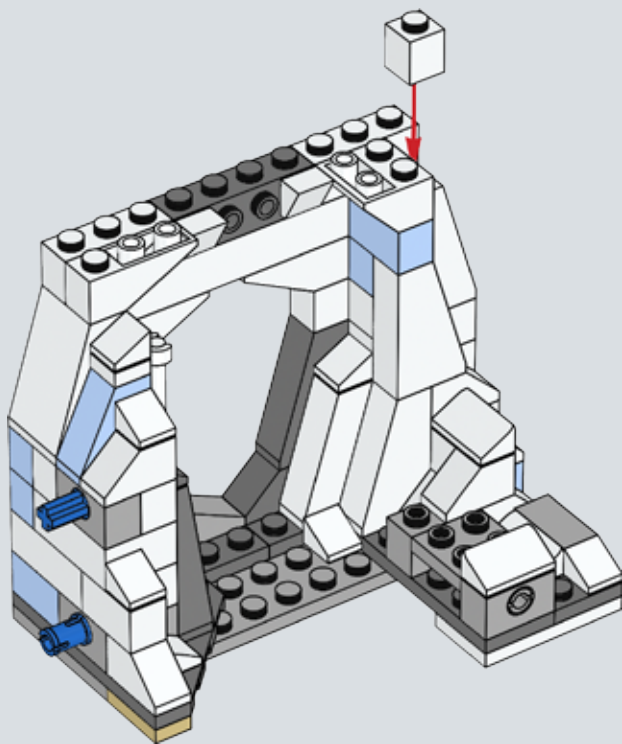

# 159

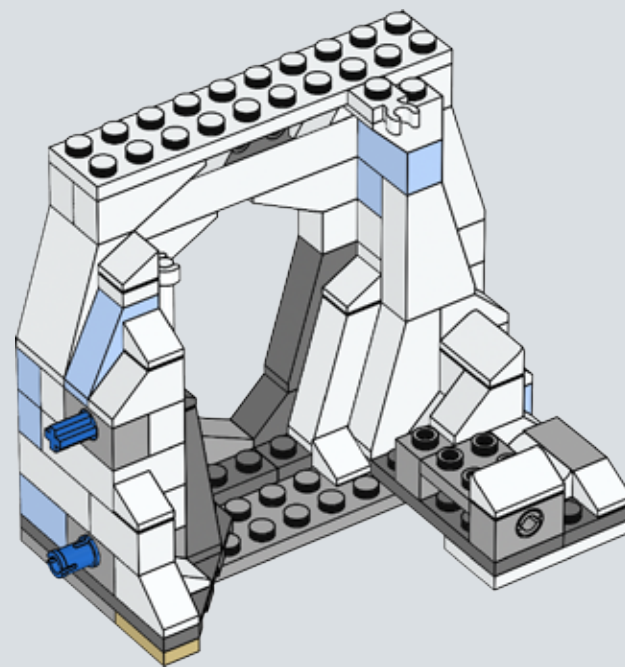

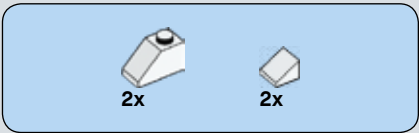

# 160

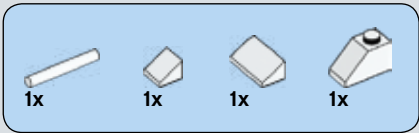
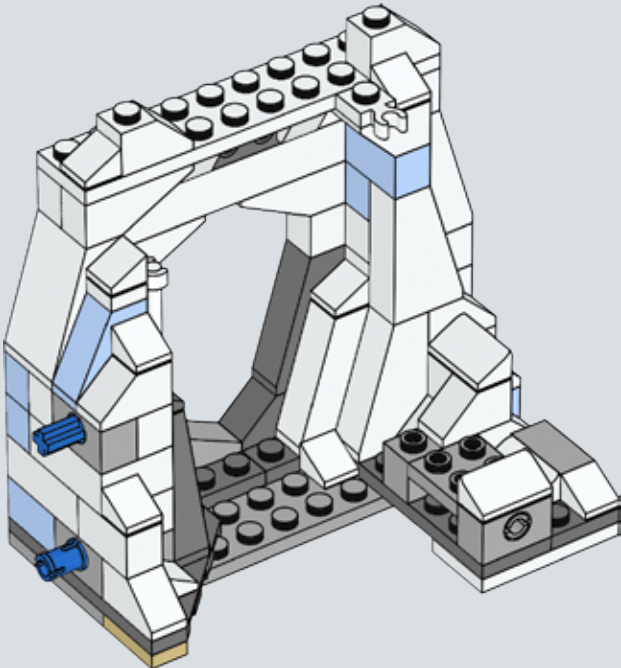

# 161

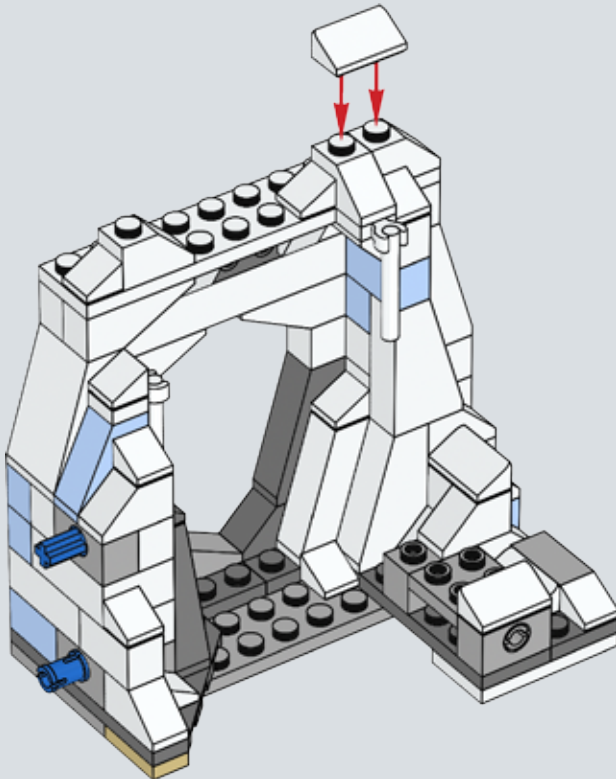



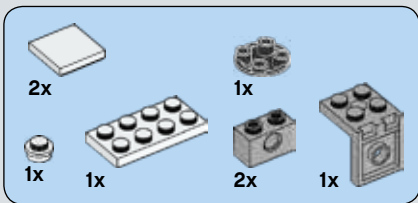

# 162

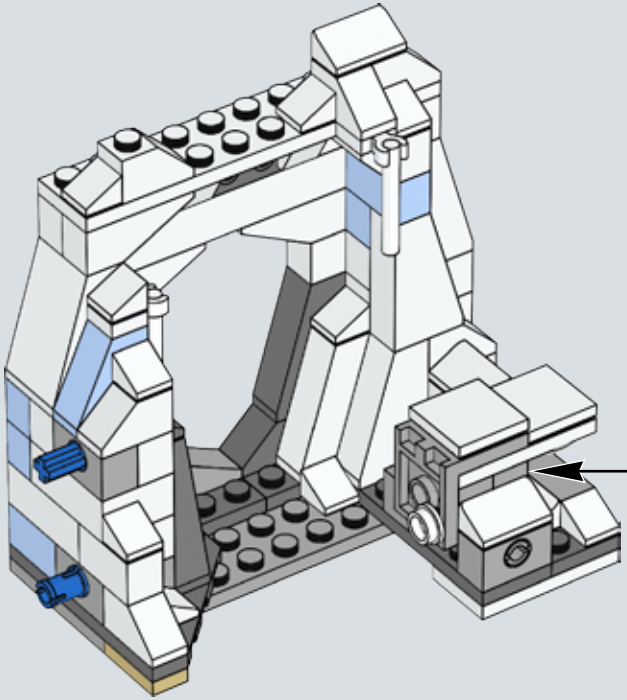
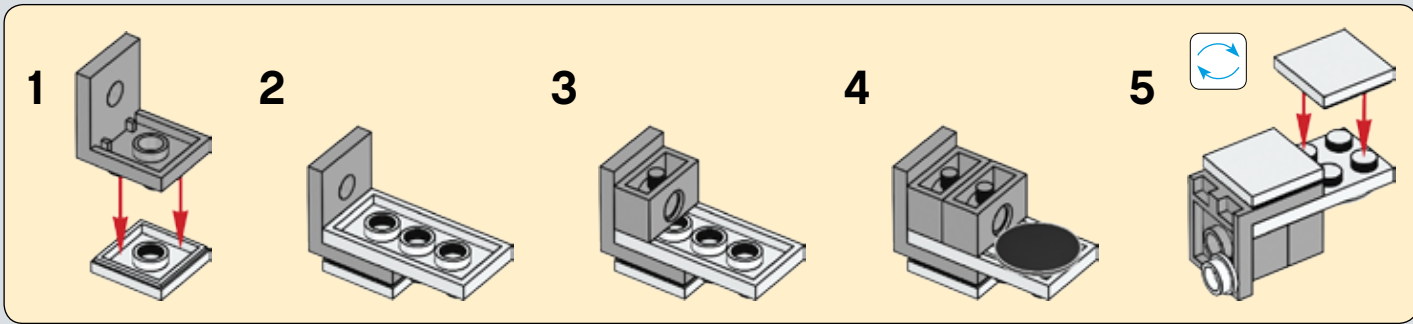



163

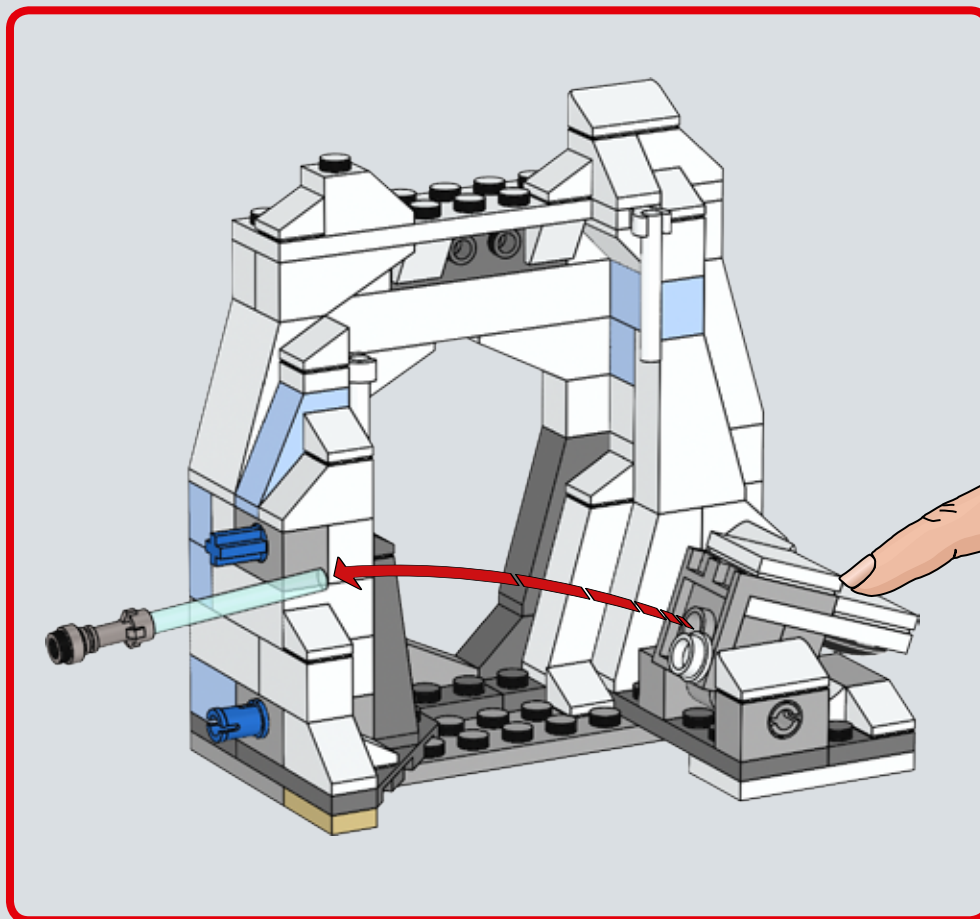
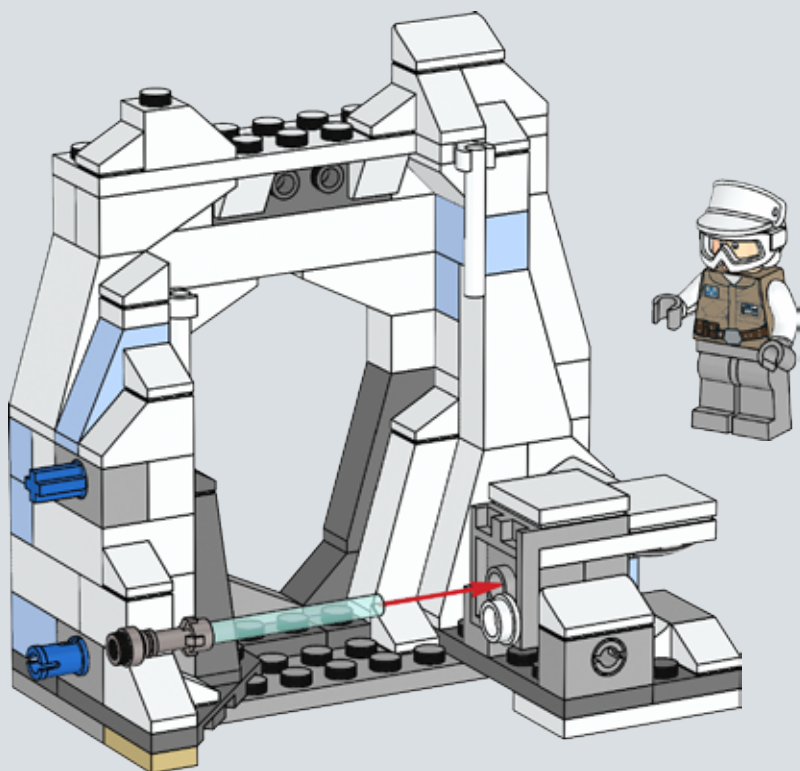

164

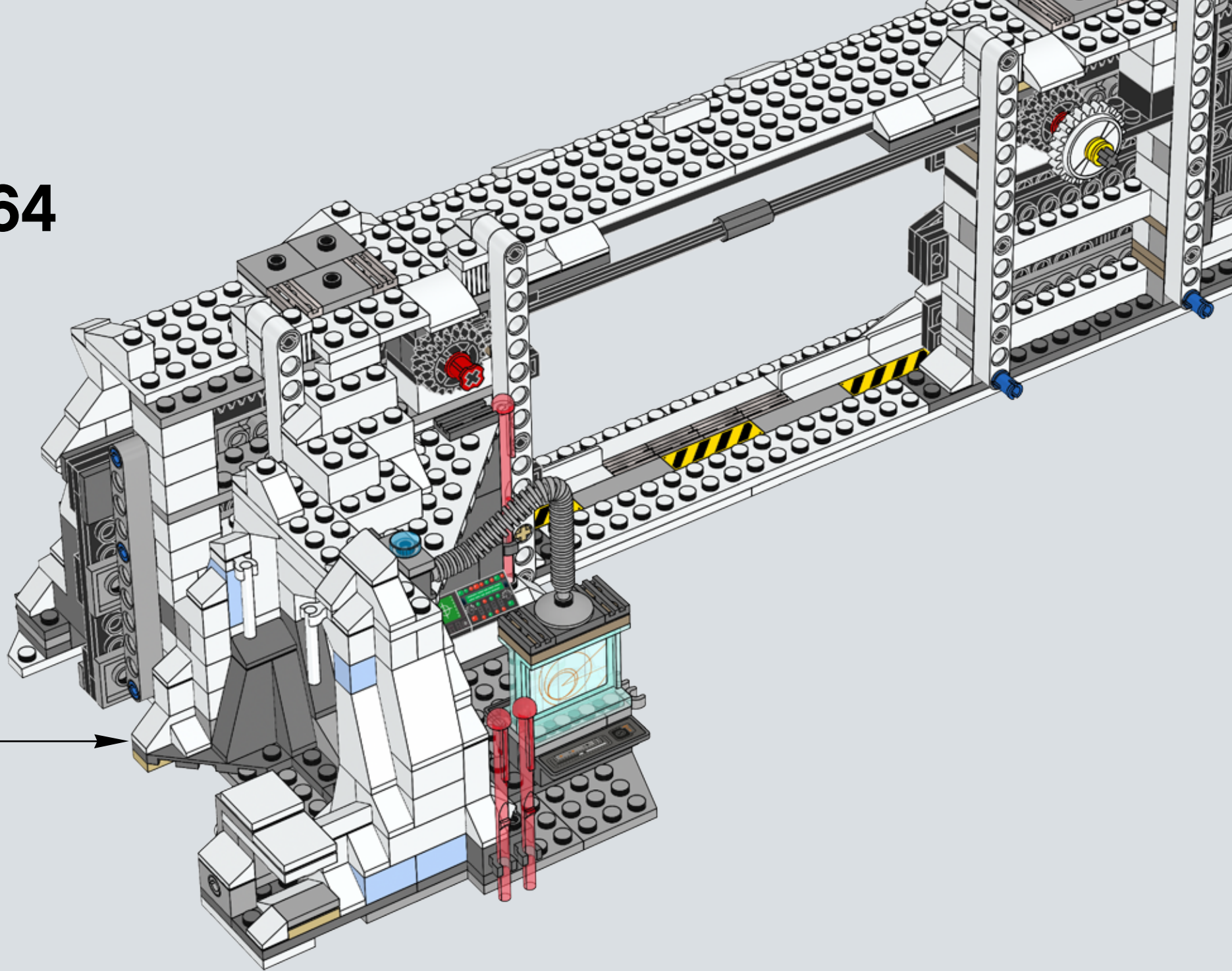

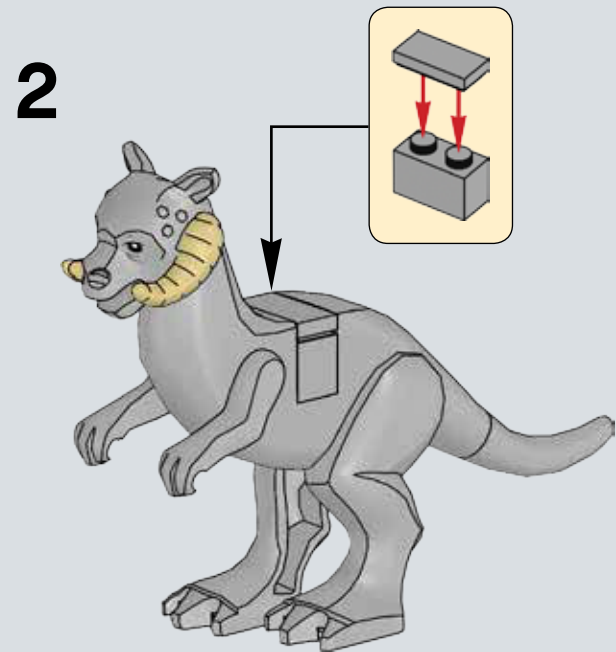
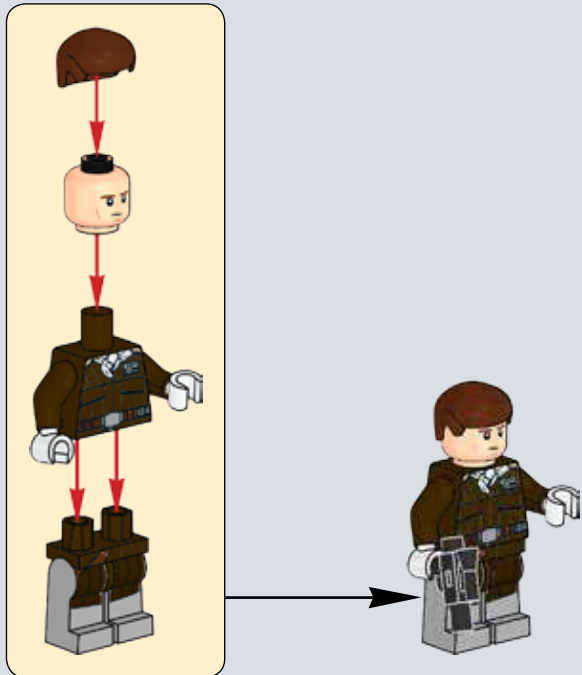
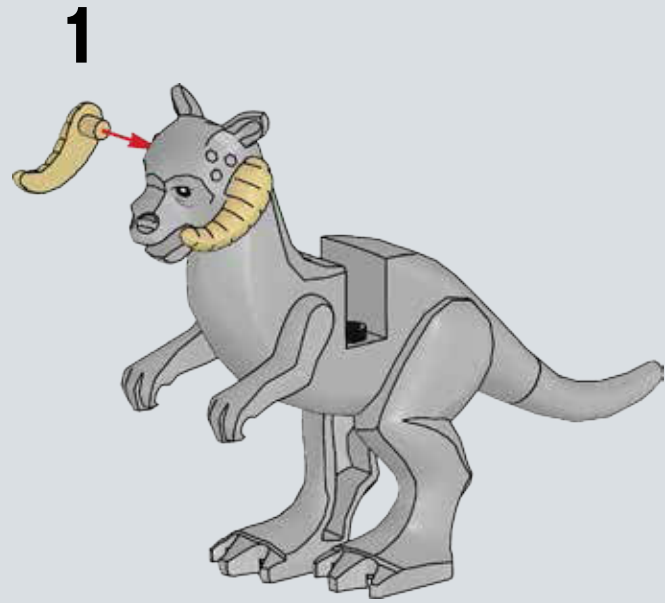
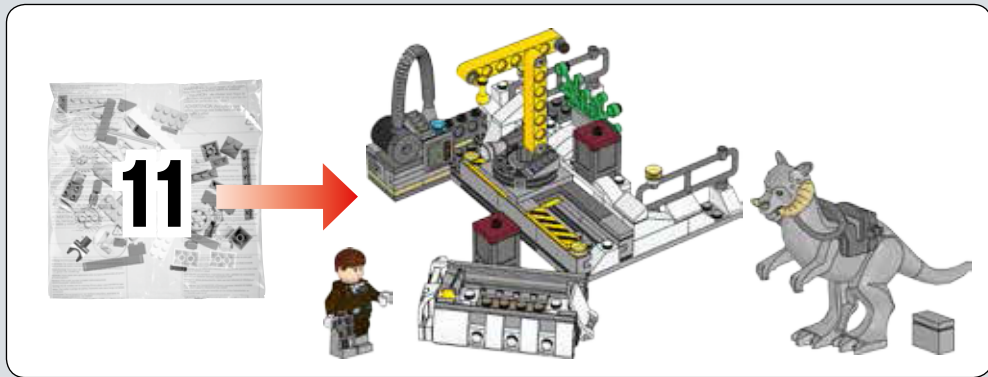



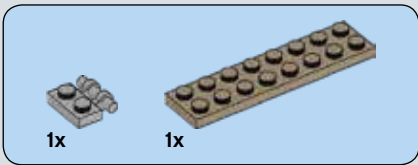

# 165

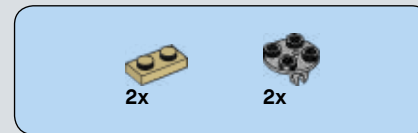
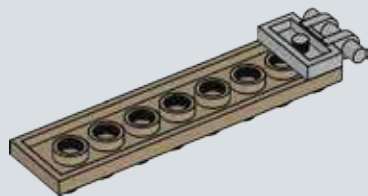

# 166

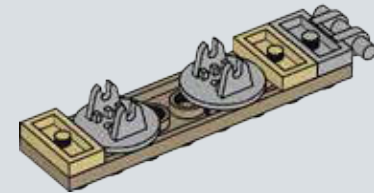

# 167

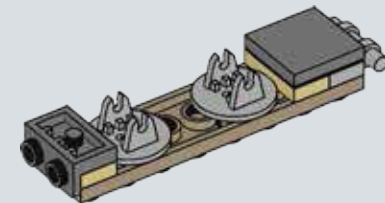



4x



1x

# 168

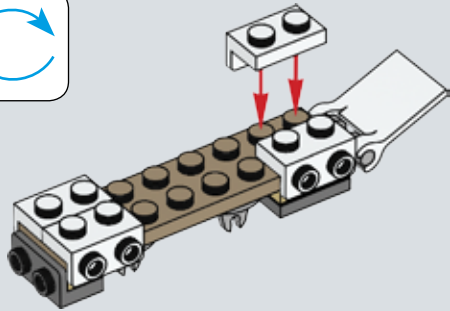

4x



1x

# 169

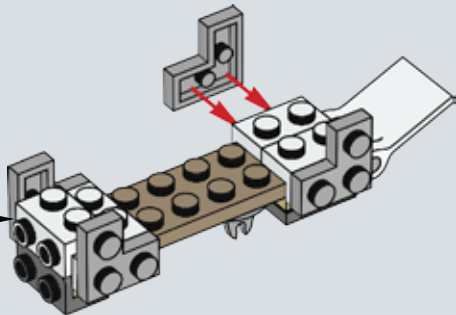
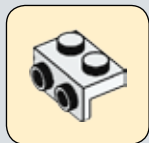

1x



1x

# 170

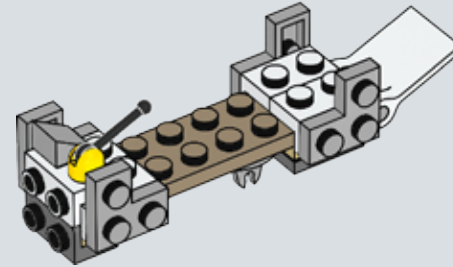

2x

# 171

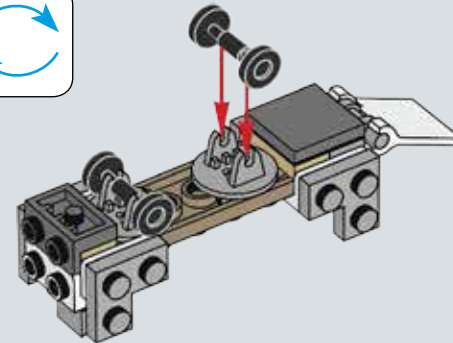
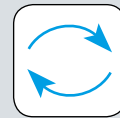

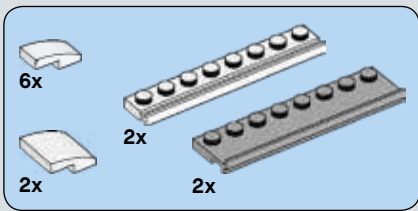

# 172

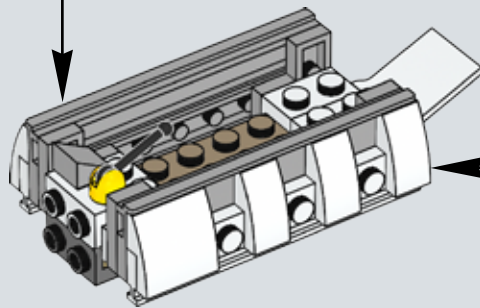
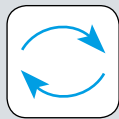
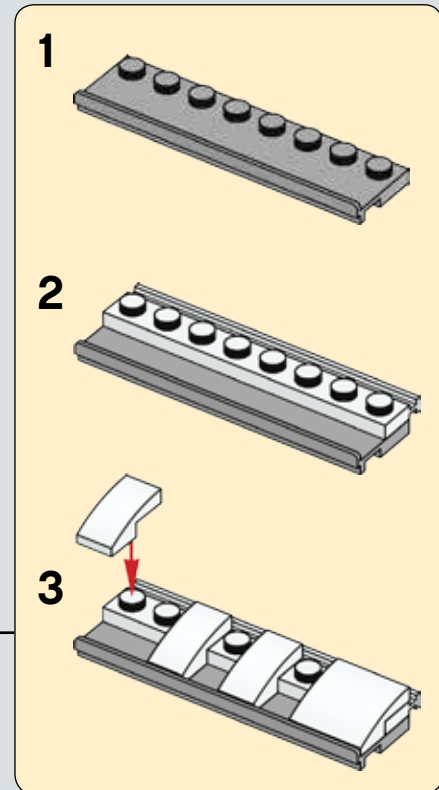
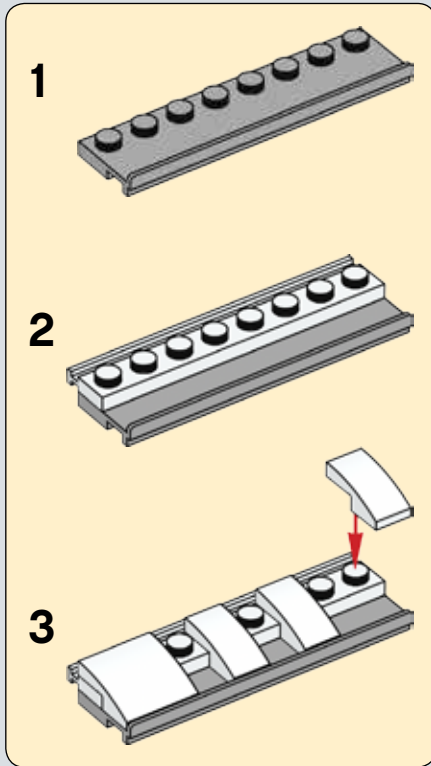

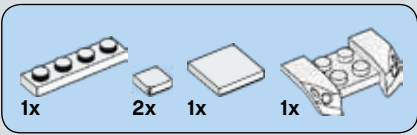

# 173

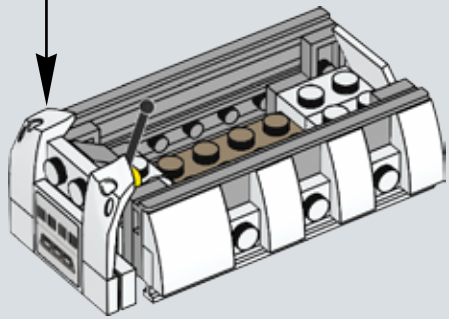
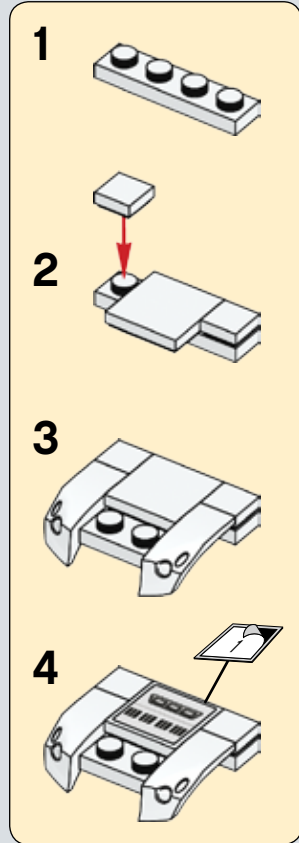

# 174

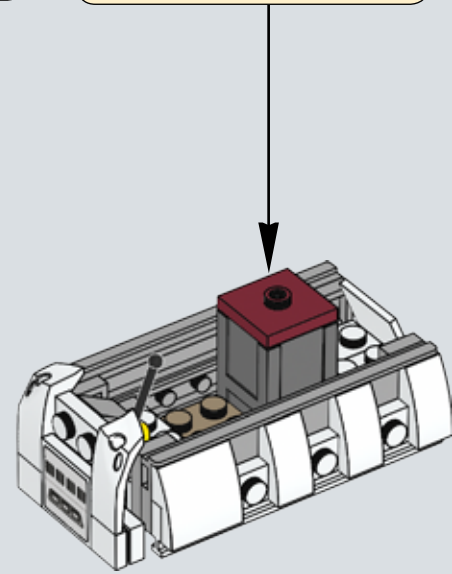
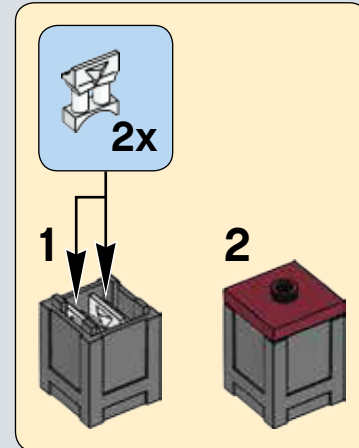
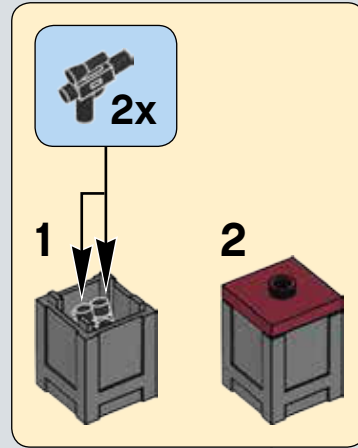



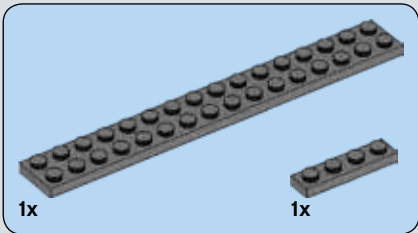
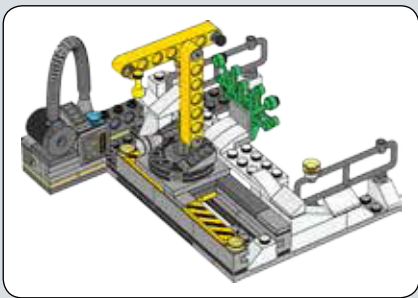

# 175

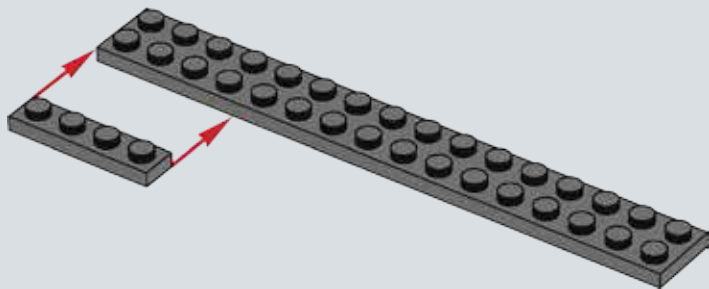

# 176

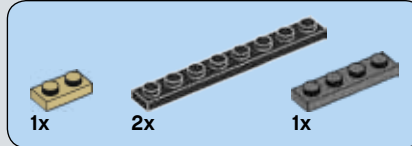
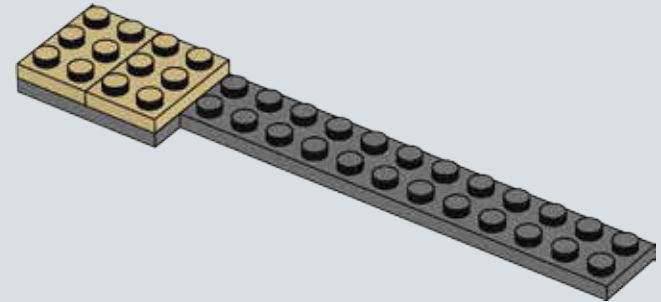

# 177

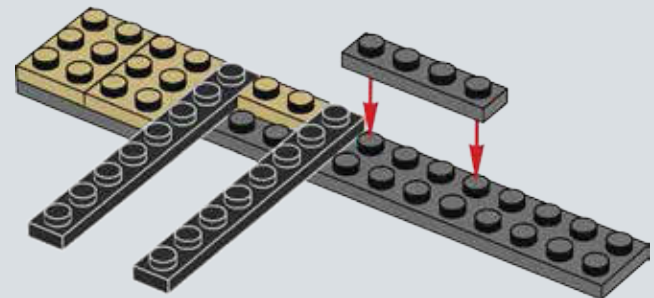

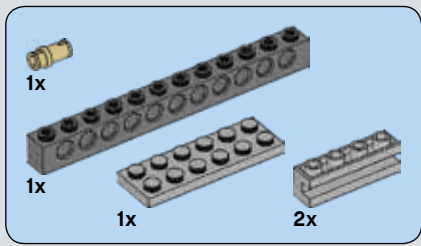

# 178

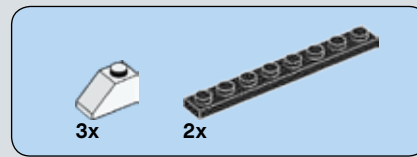
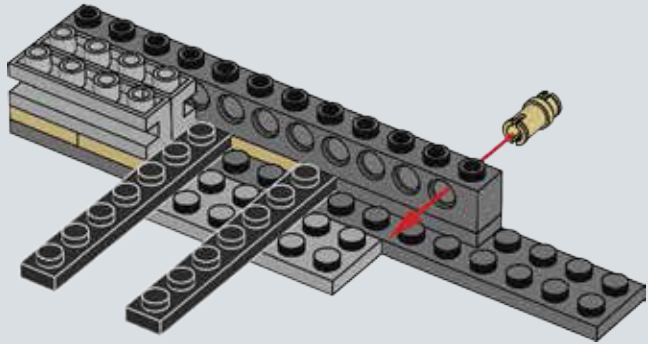

# 179

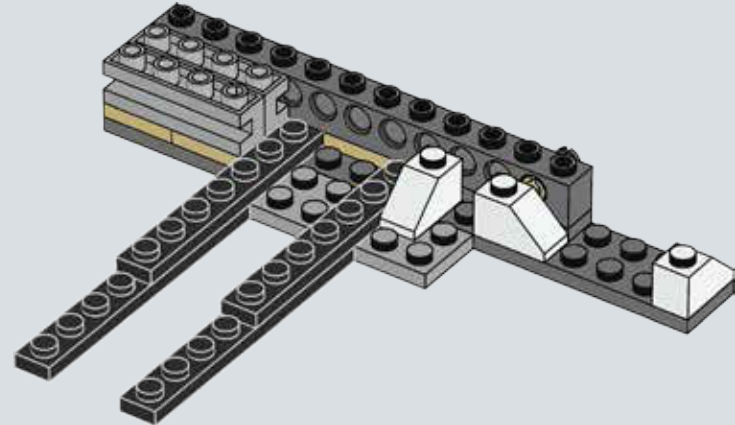

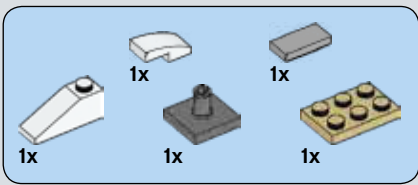

# 180

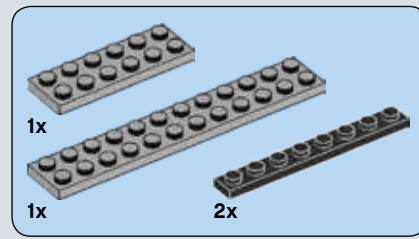
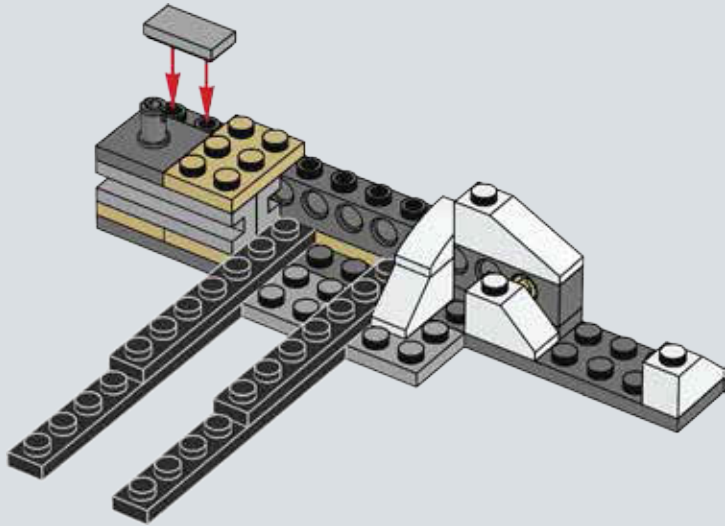

# 181

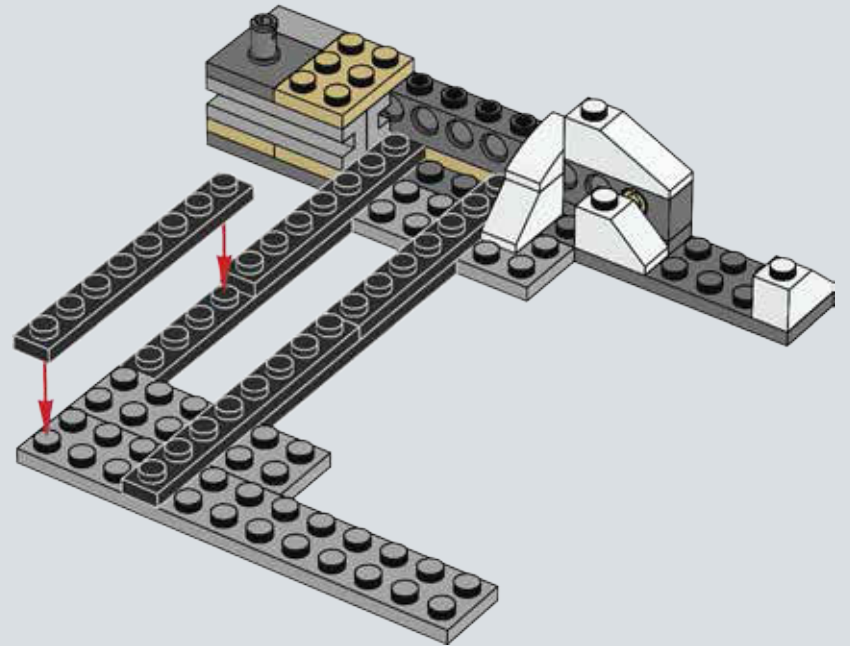

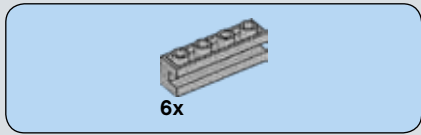

# 182

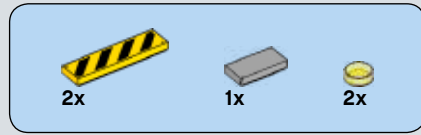
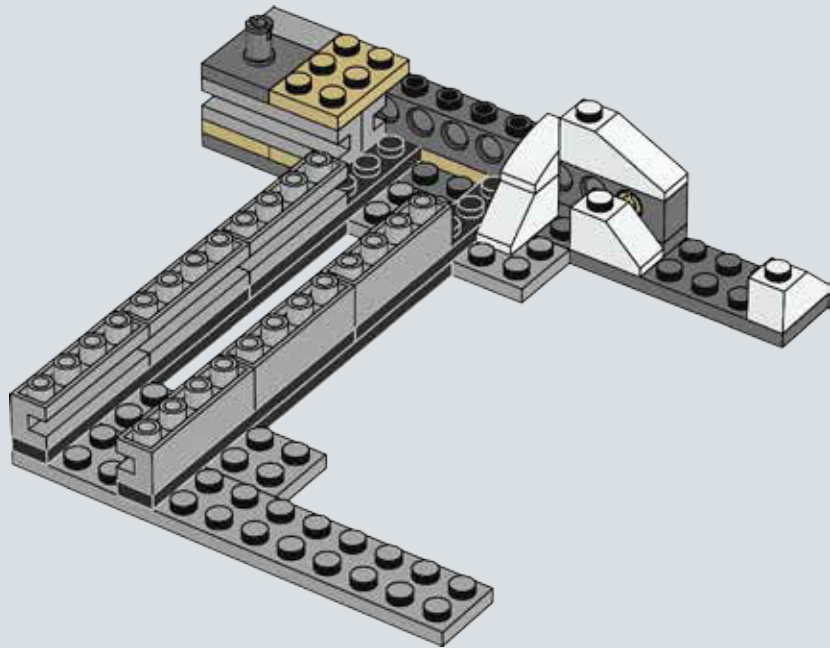

# 183

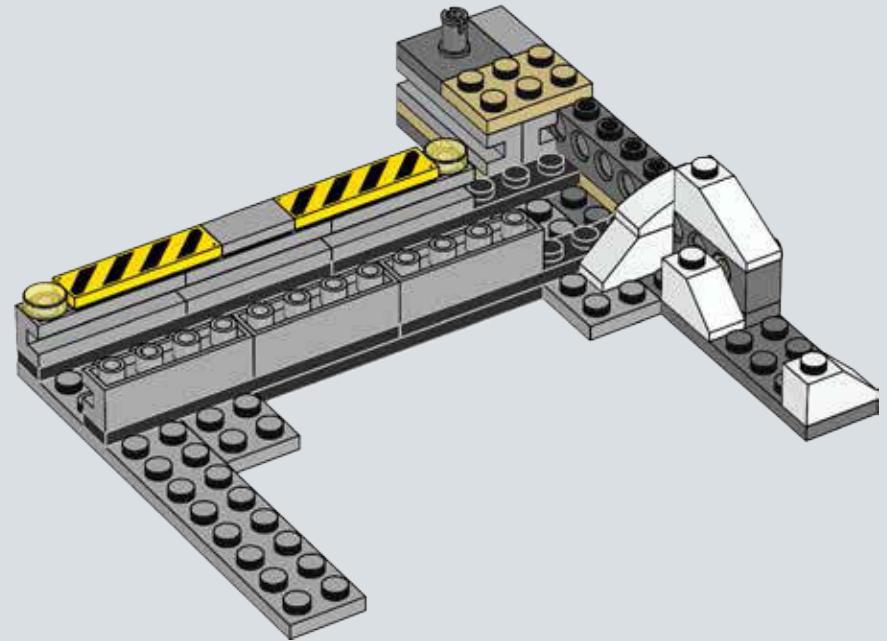



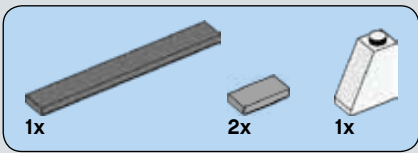

# 184

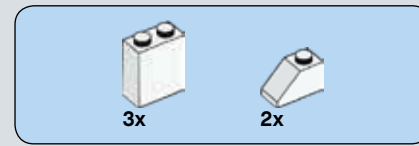
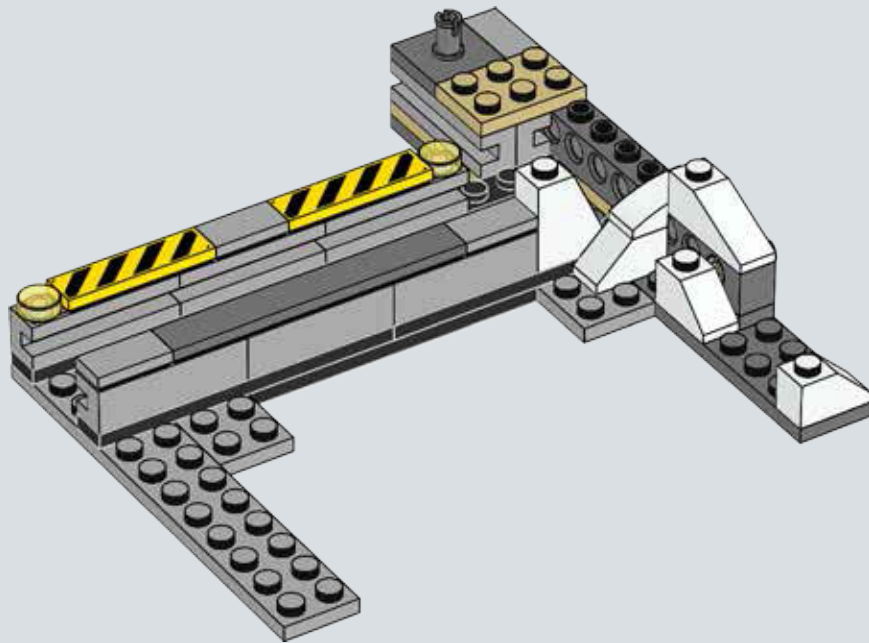

# 185

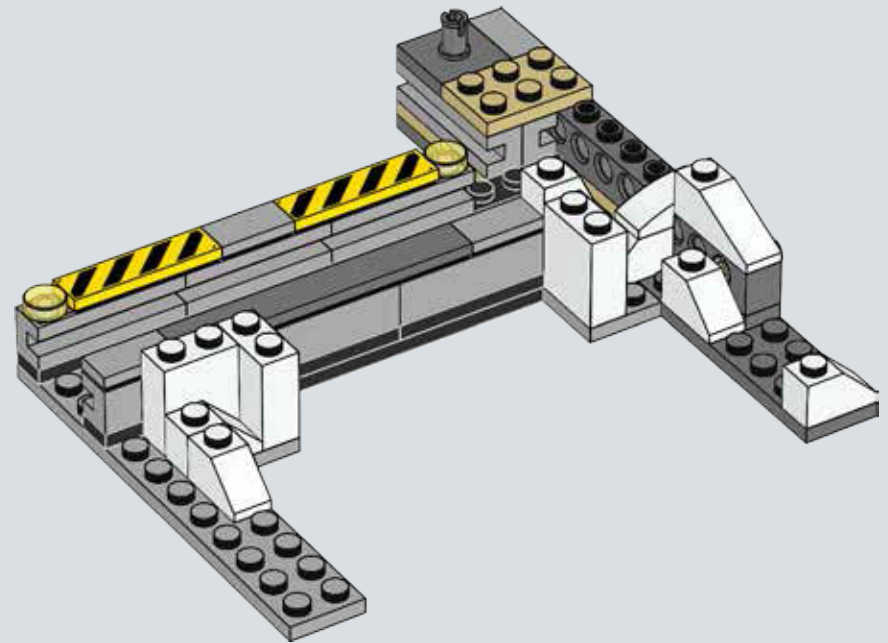

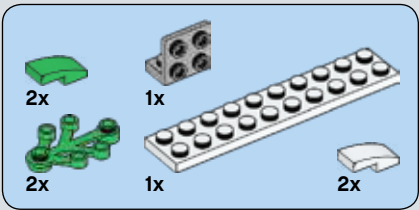

# 186

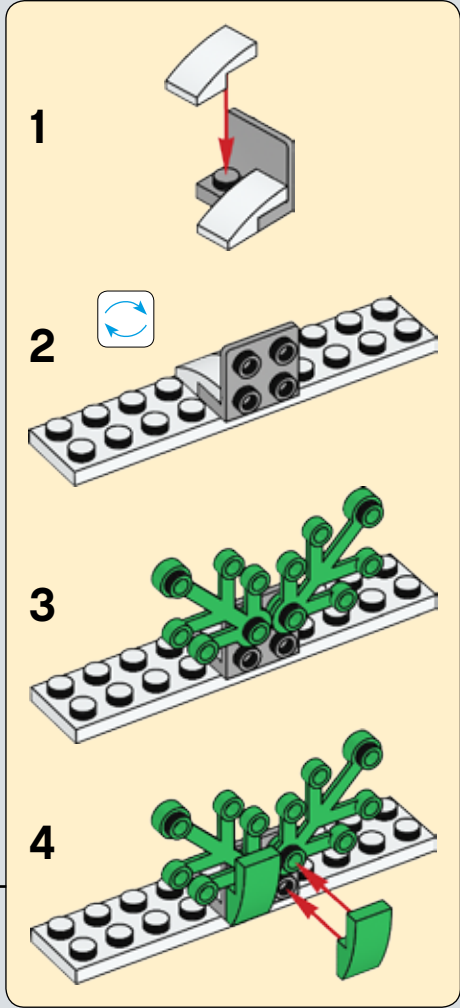
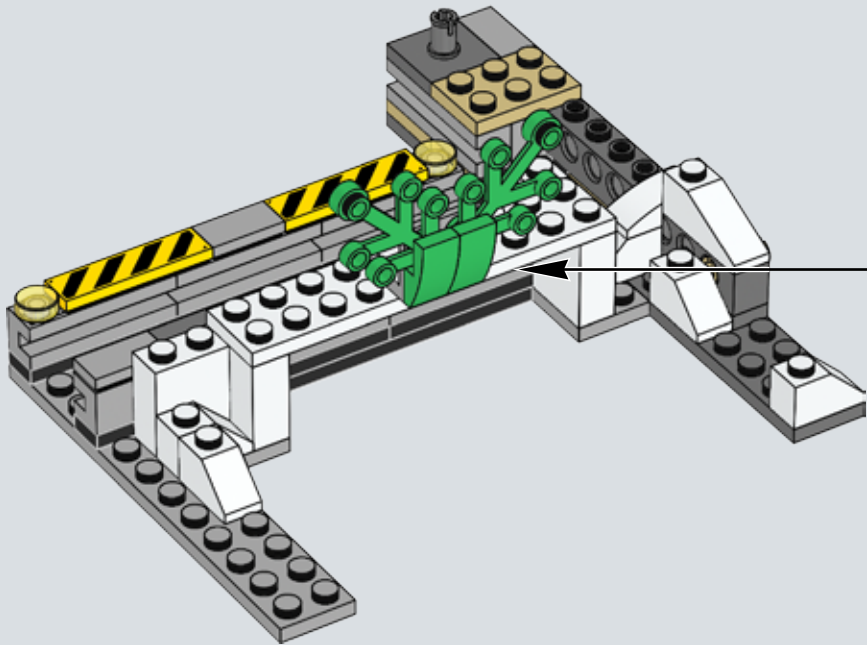

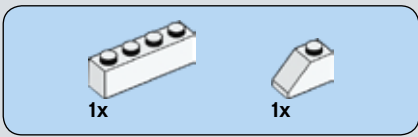

# 187

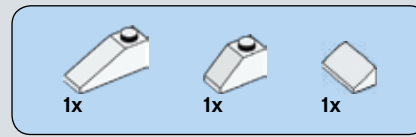
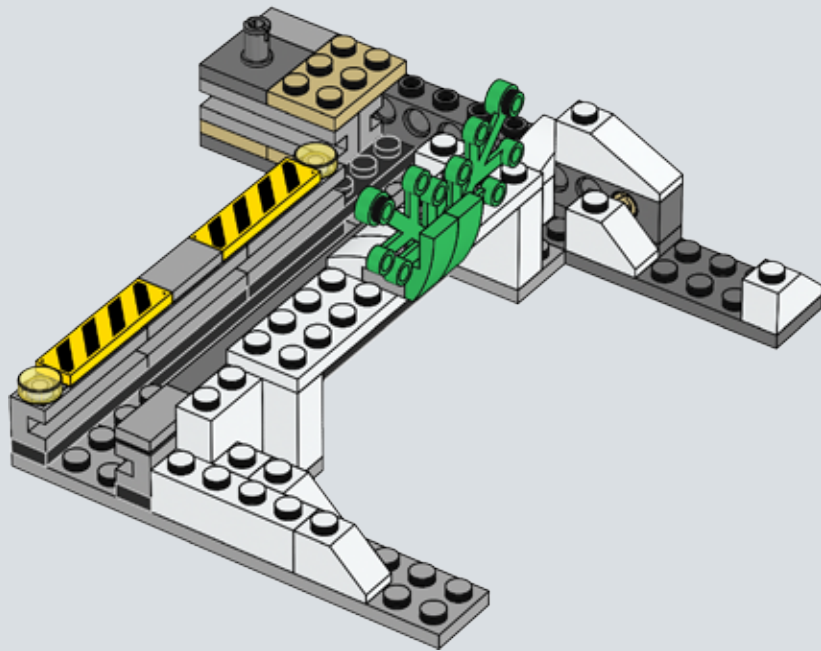

# 188

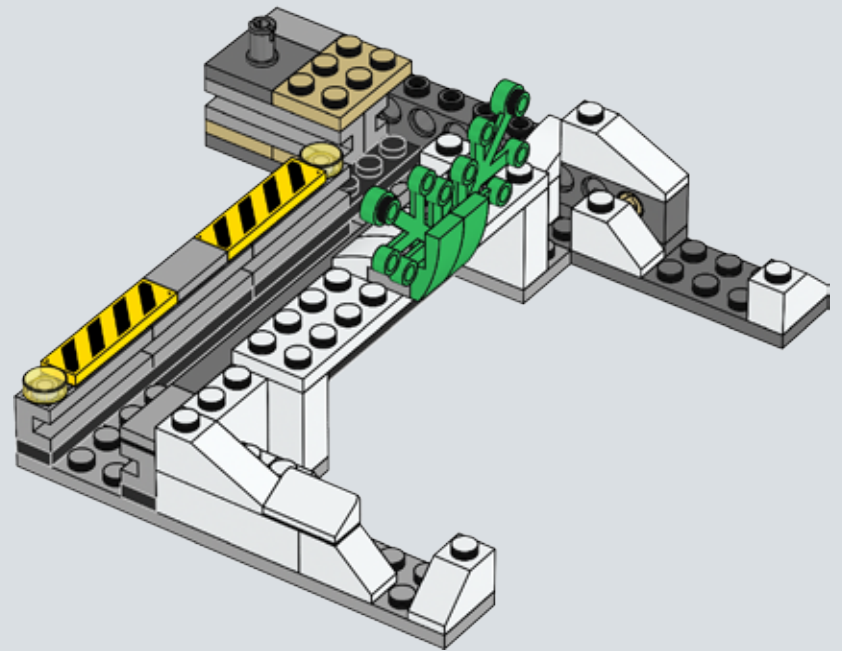

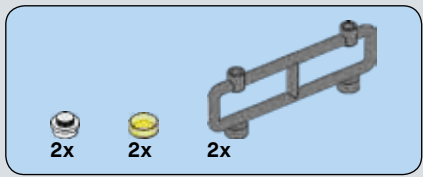

# 189

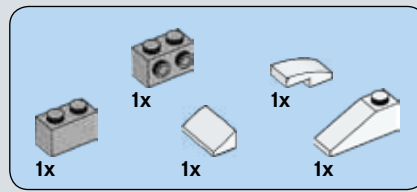
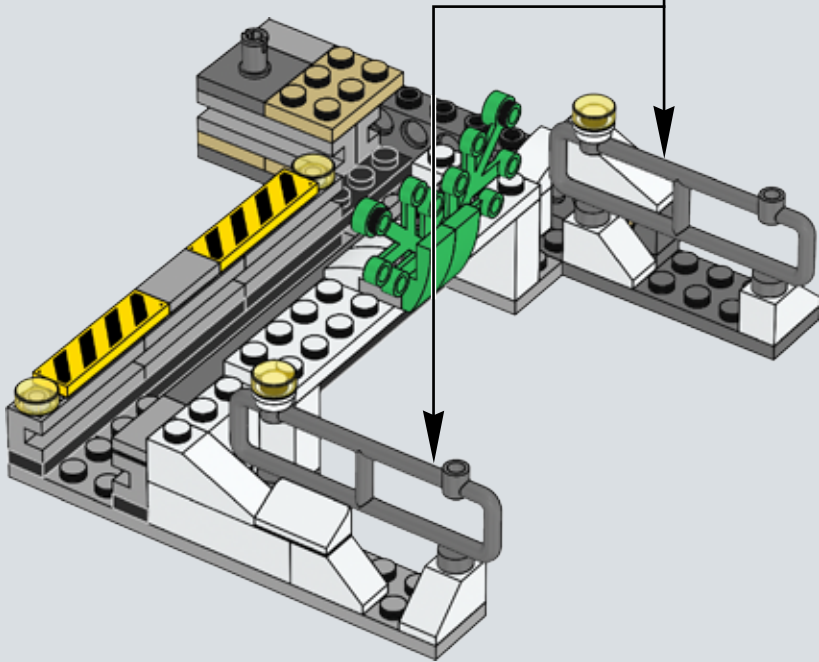
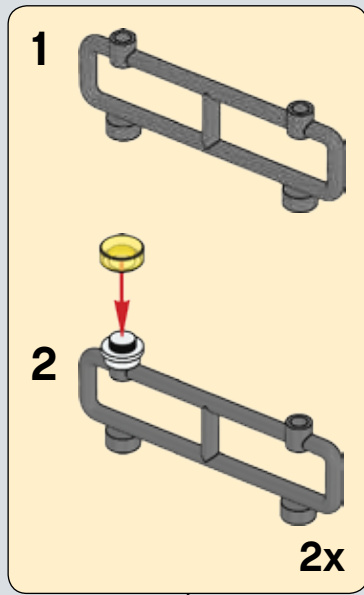

# 190

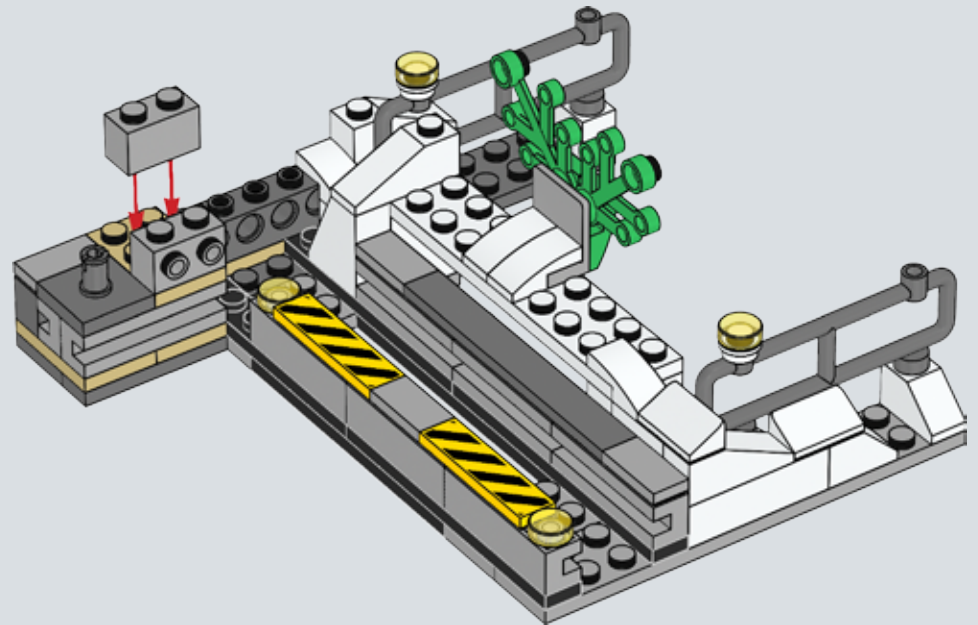





# 191

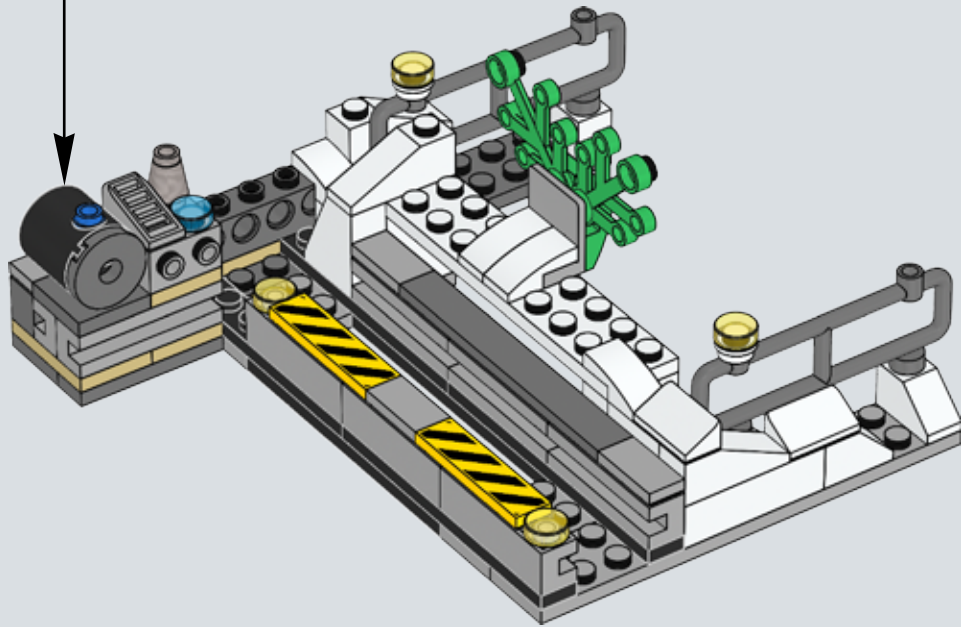
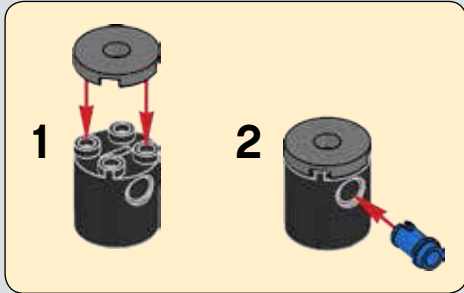

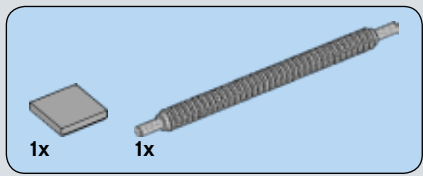

# 192

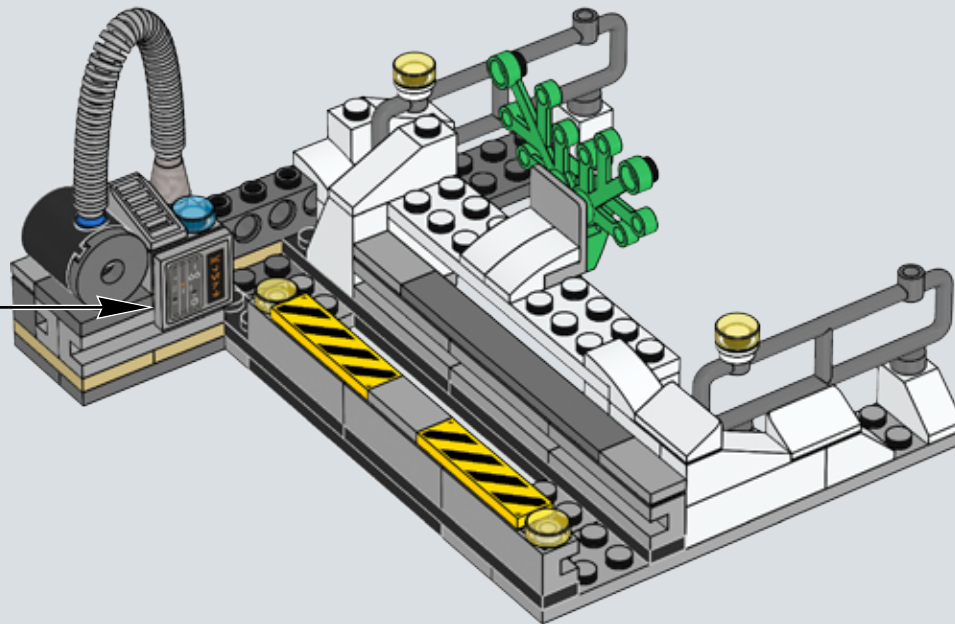
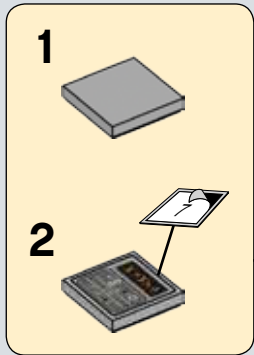



# 193

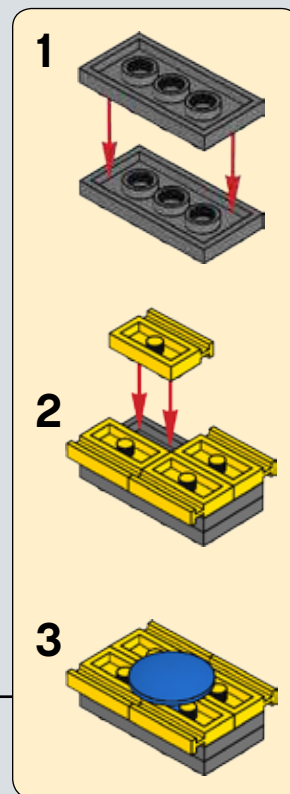
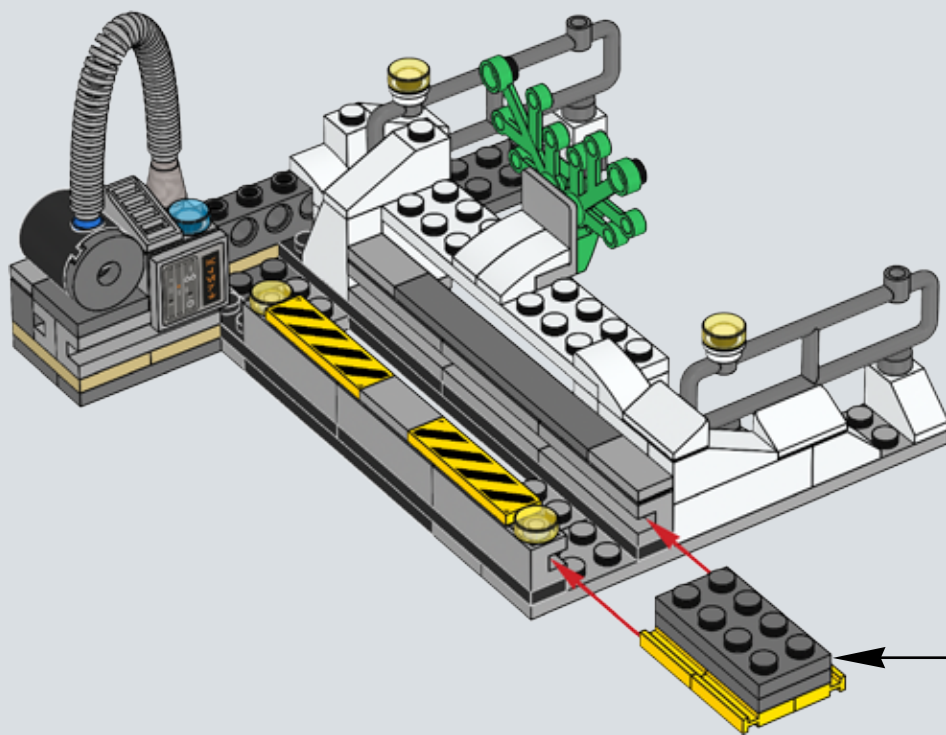

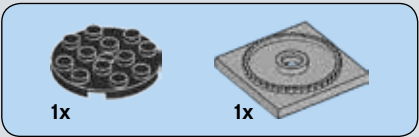

# 194

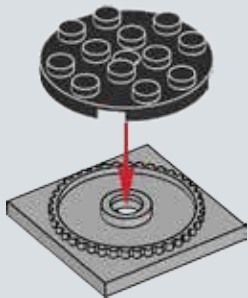

# 195

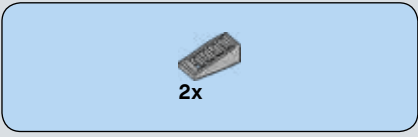
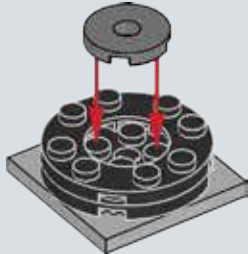

# 196

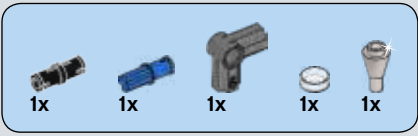
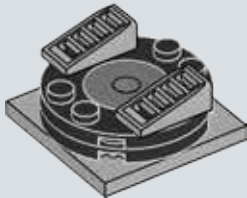

# 197

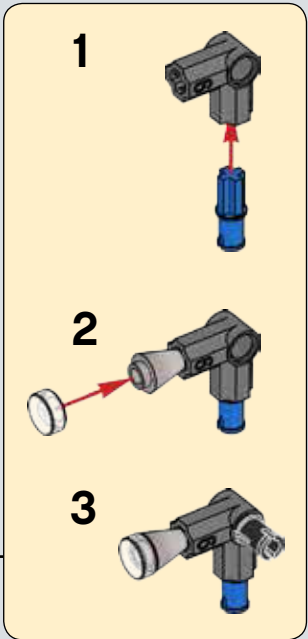
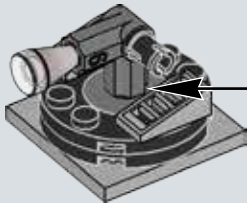



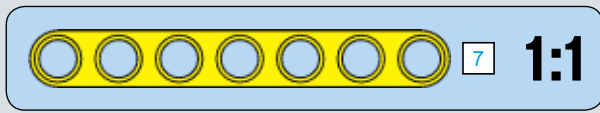
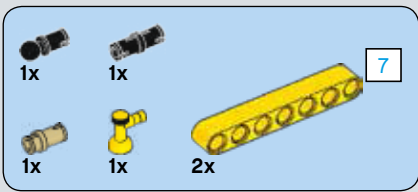

198

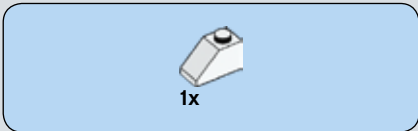
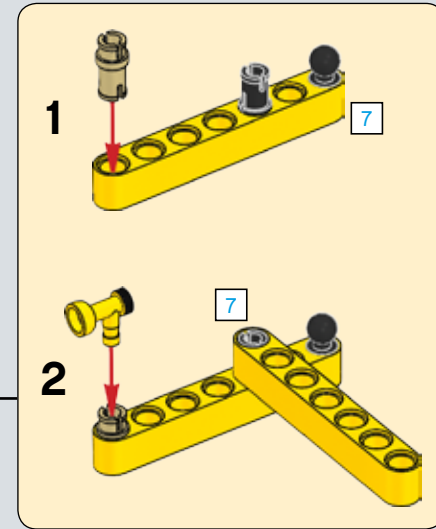
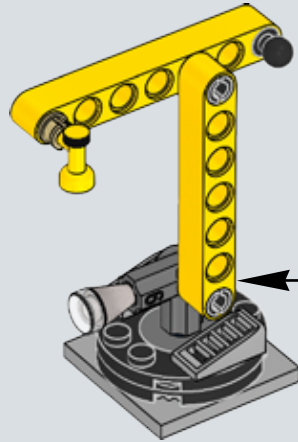

199

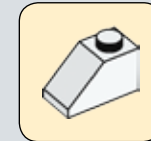
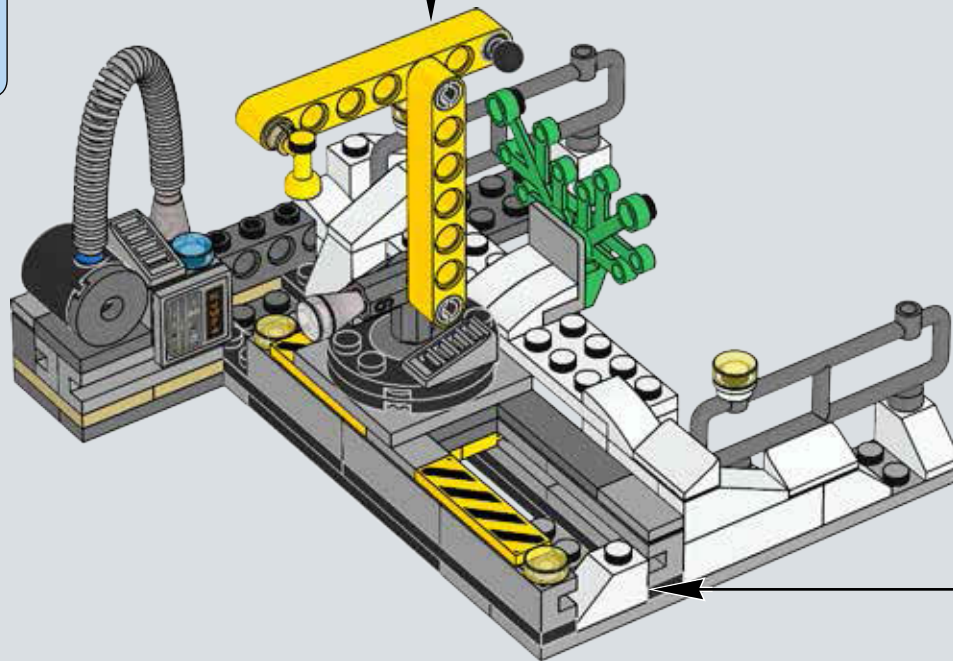

200

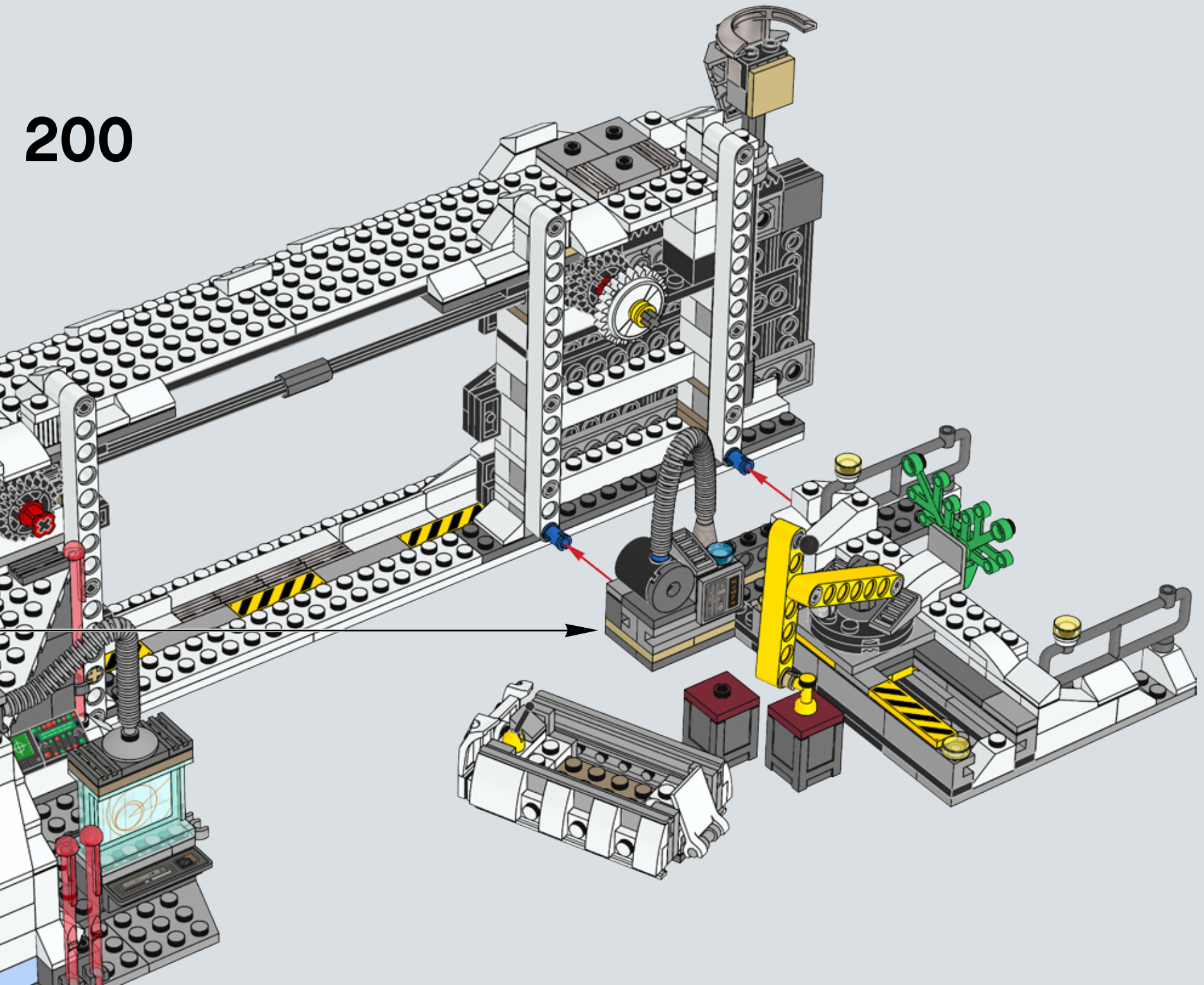

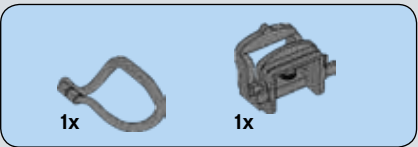

# 201

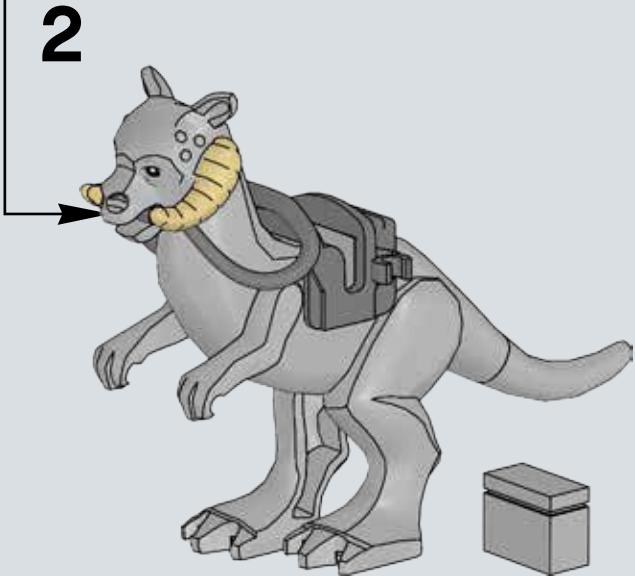
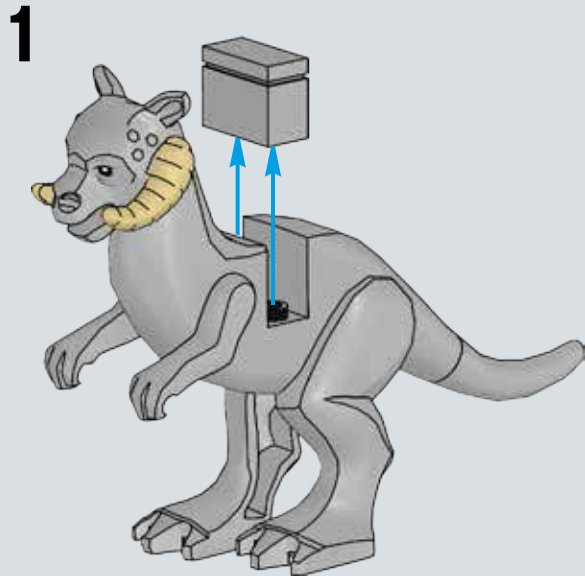
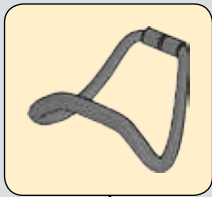

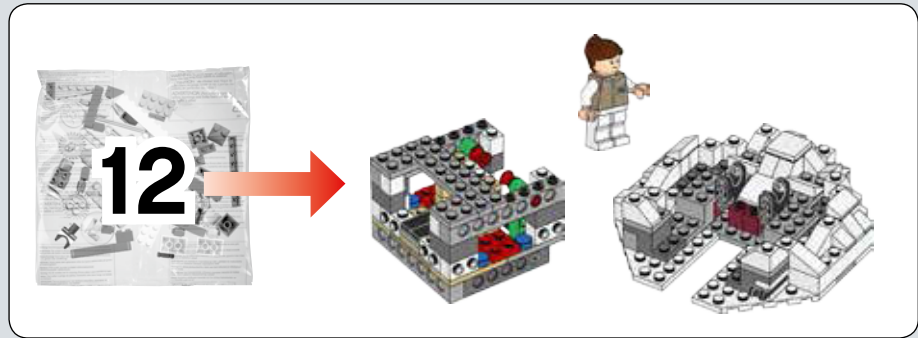

1

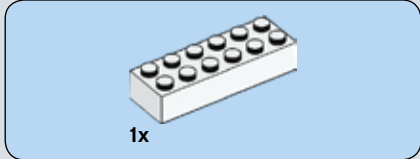
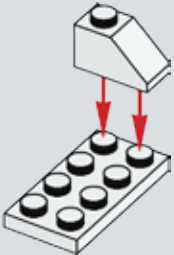

2

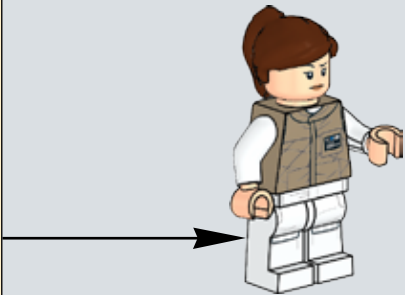
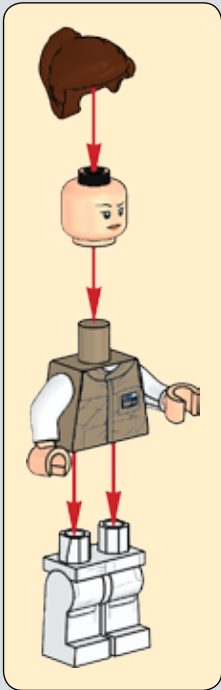
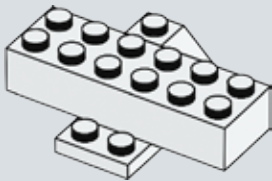



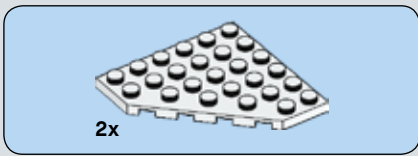

3

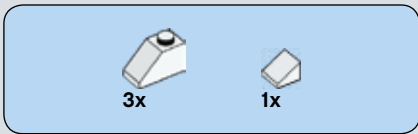
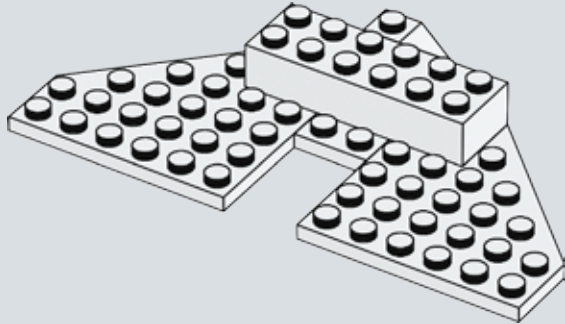

4

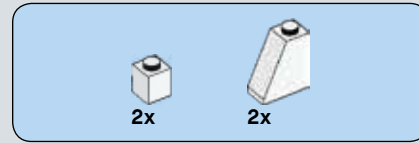
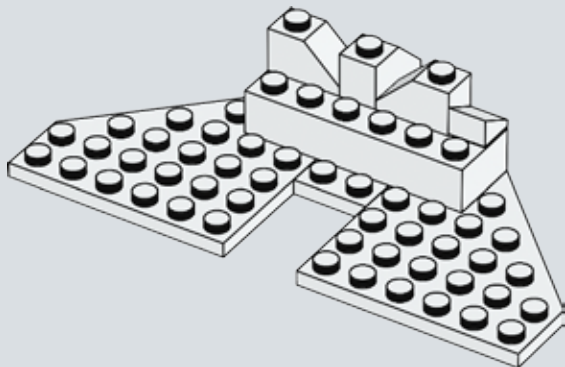

5

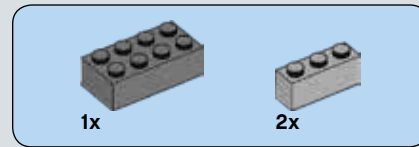
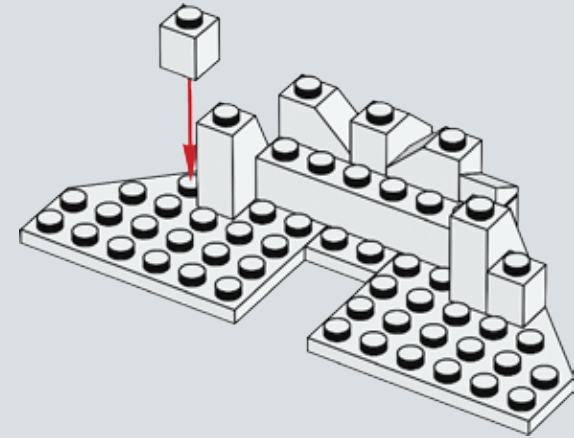

6

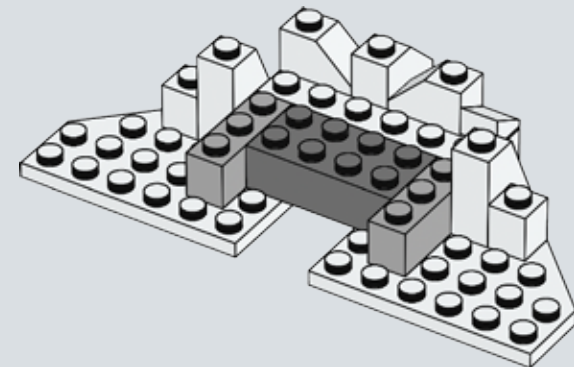

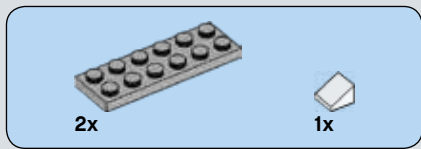

7

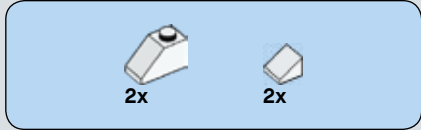
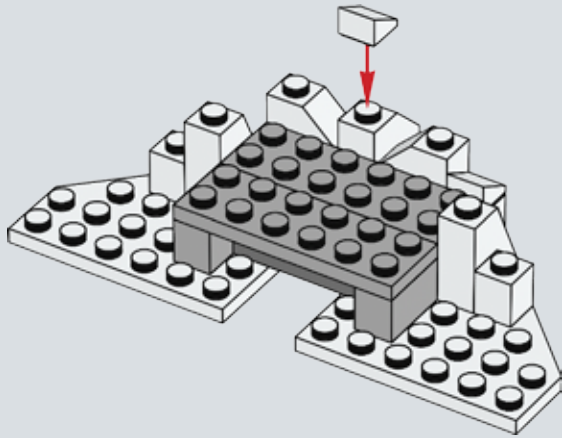

8

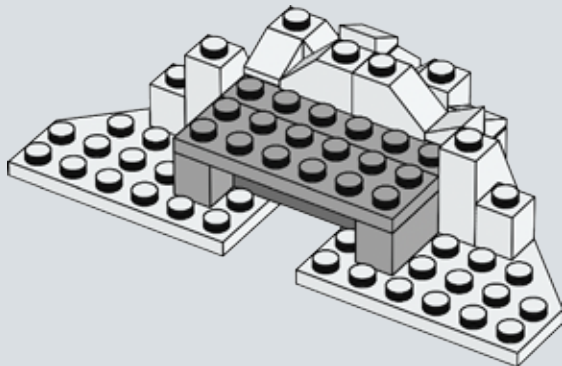

9

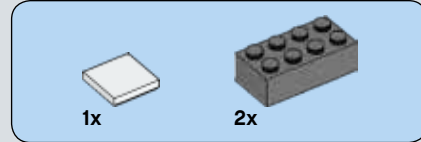
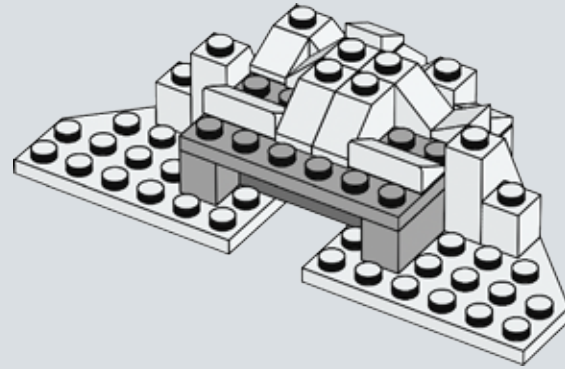

10

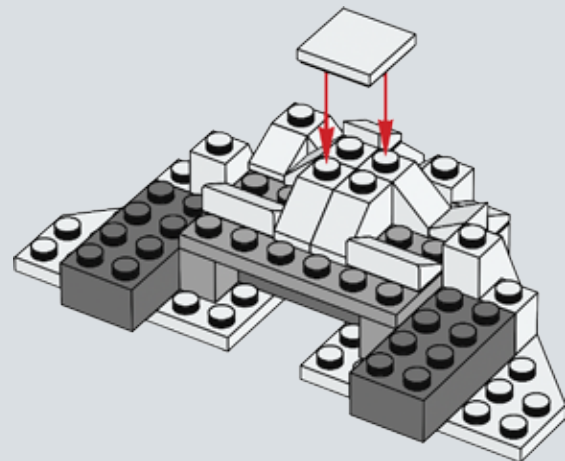

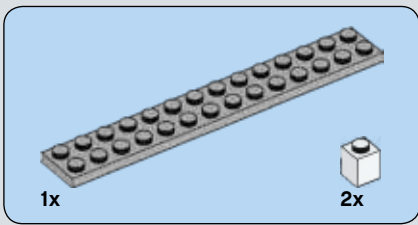

11

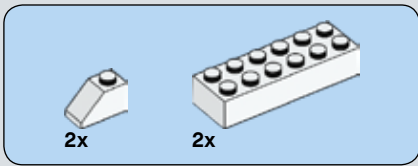
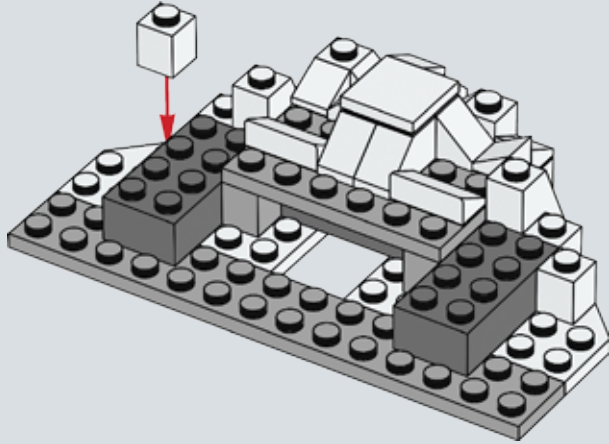

12

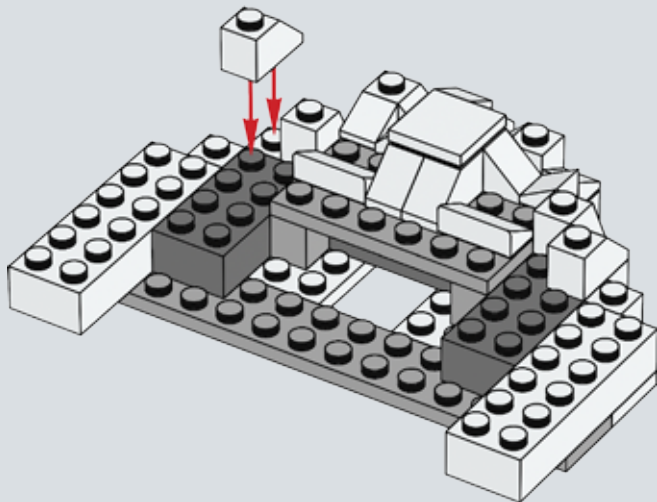

13

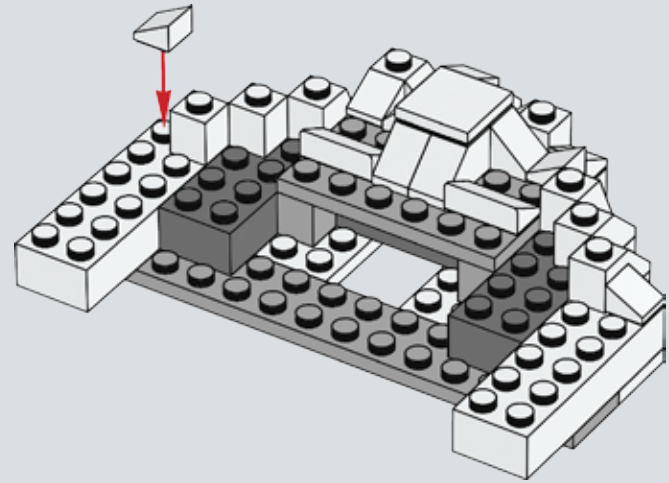

14

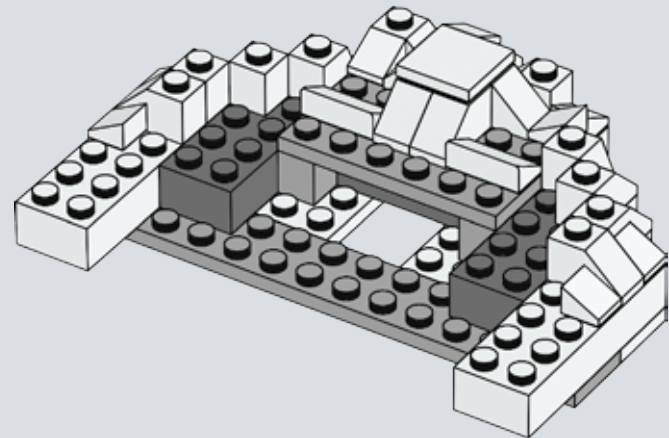

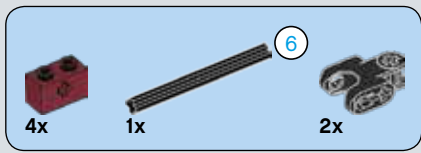

# 15

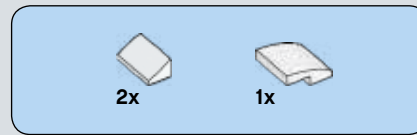
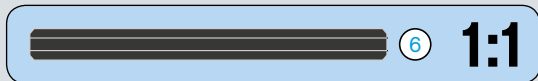
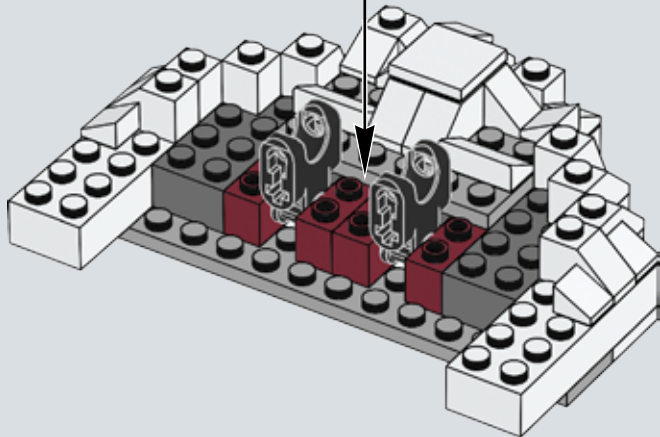
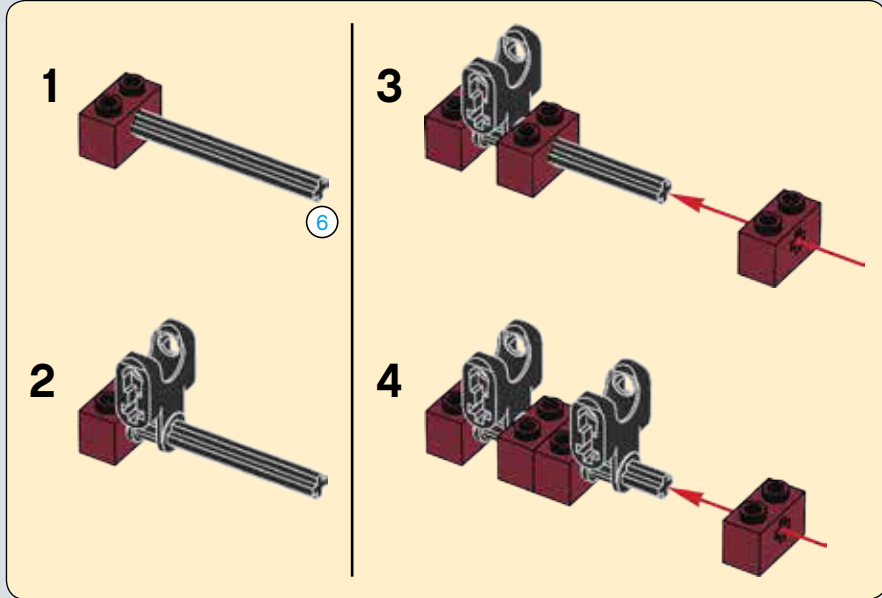

# 16

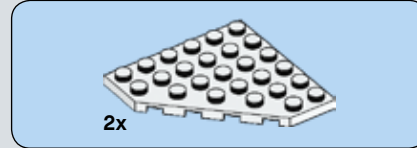
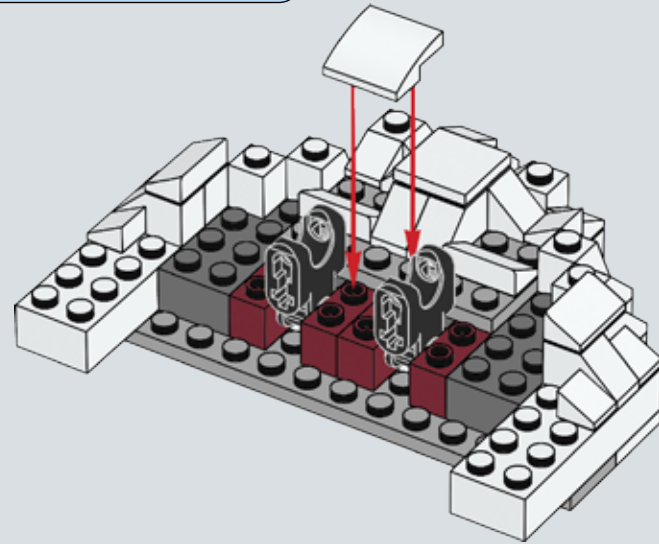

# 17

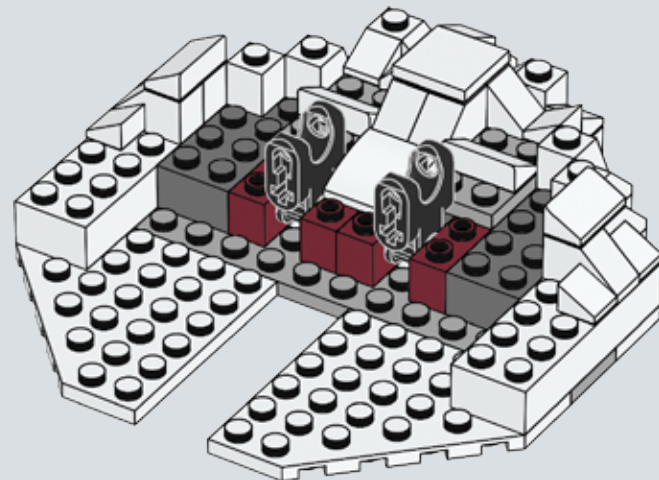



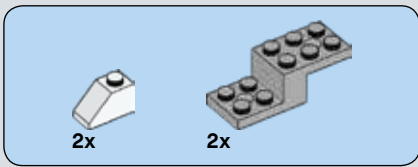

18

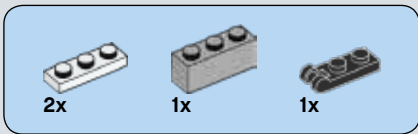
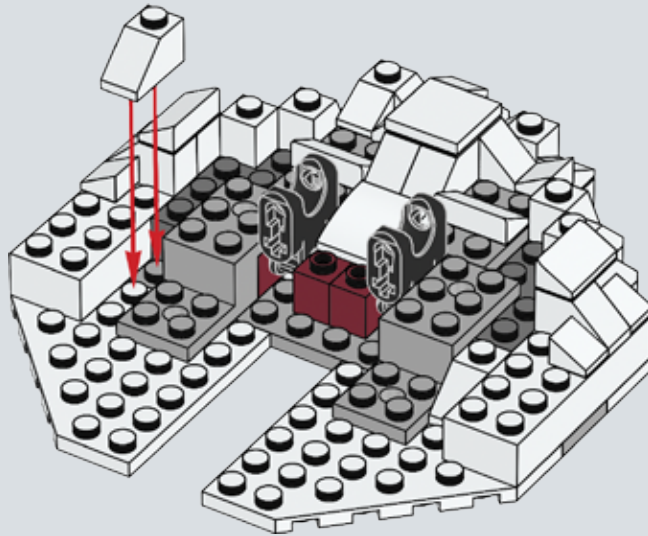

19

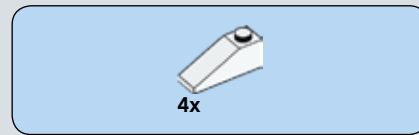
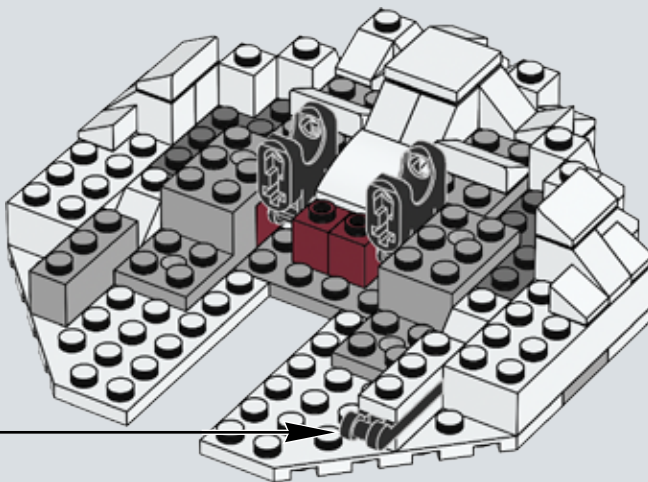
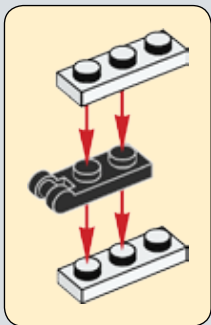

20

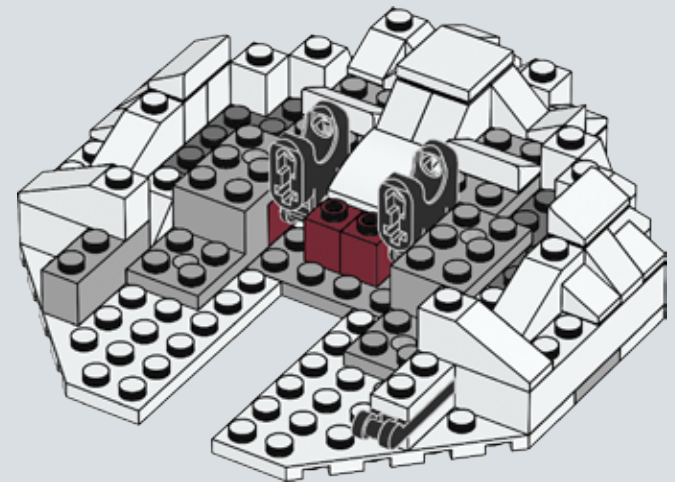

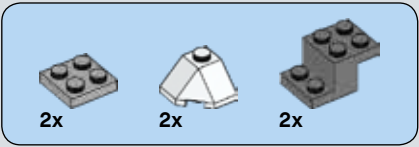

# 21

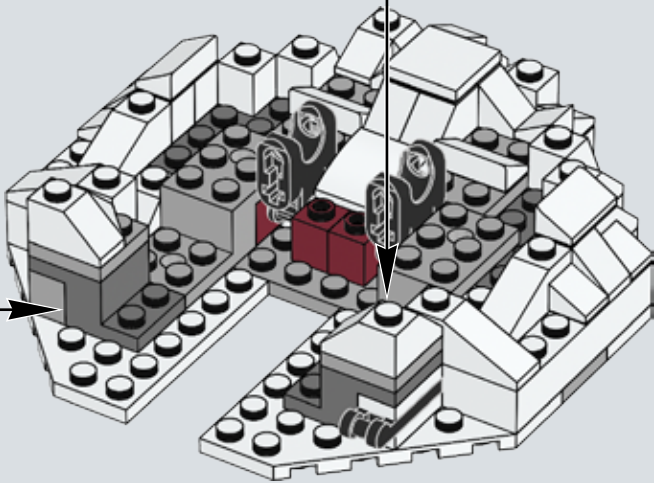
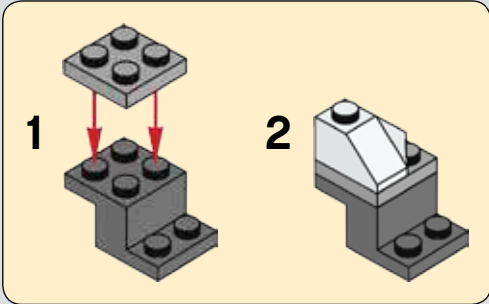
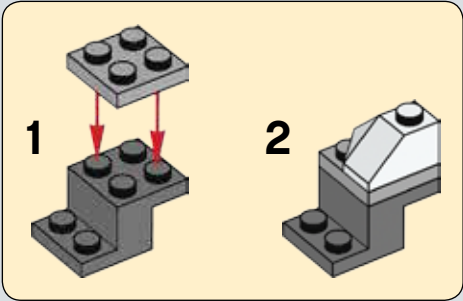

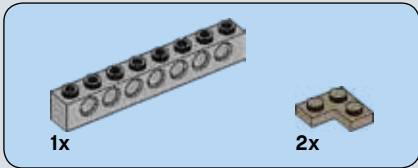
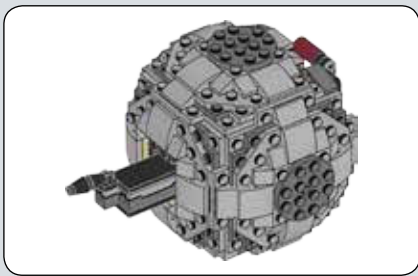

22

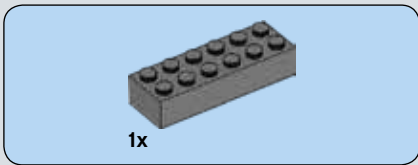
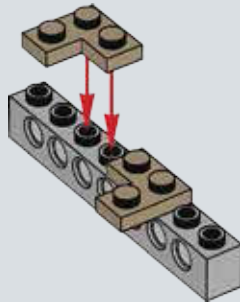

23

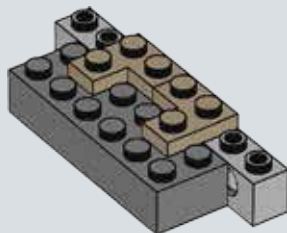

24

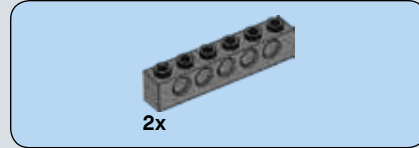
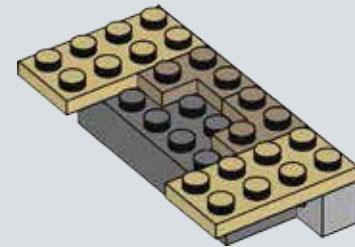

25

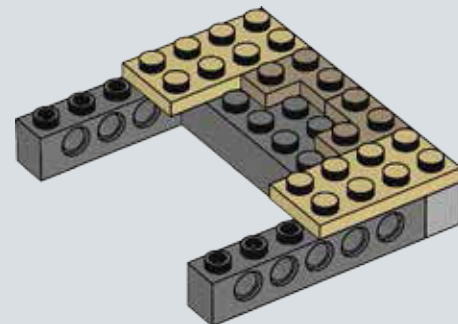



2x

# 26

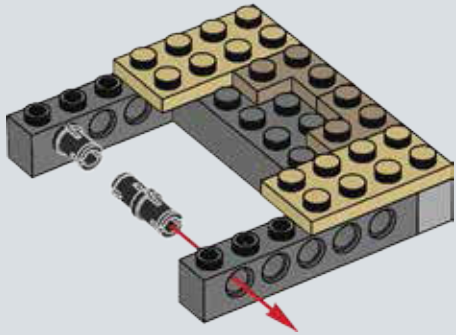

1x



2x



4x

# 27

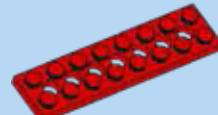
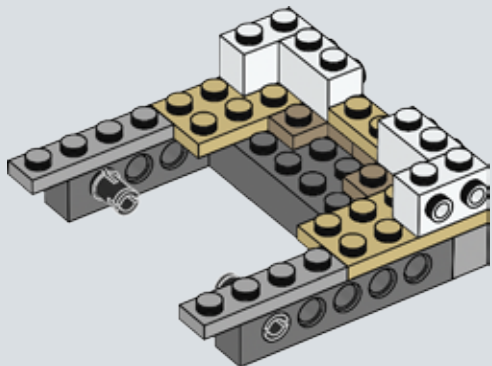

1x



4x



2x

# 28

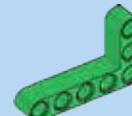
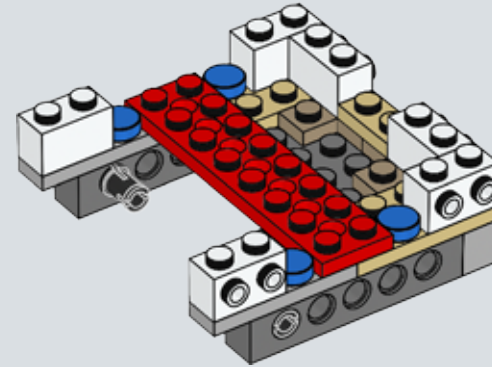

2x

# 29

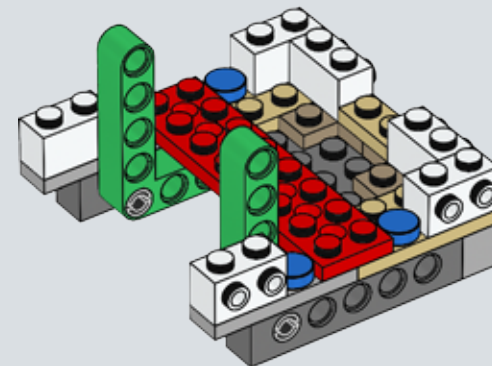





# 30

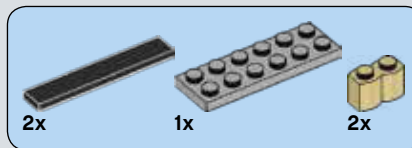
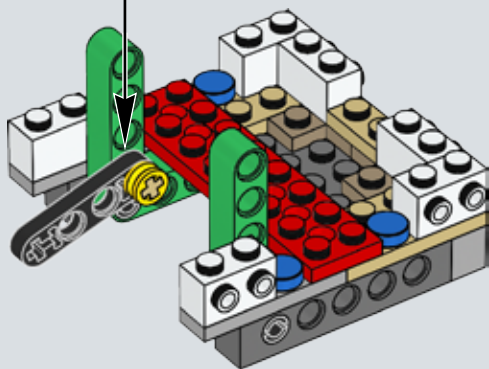
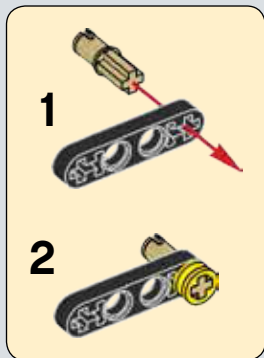

# 31

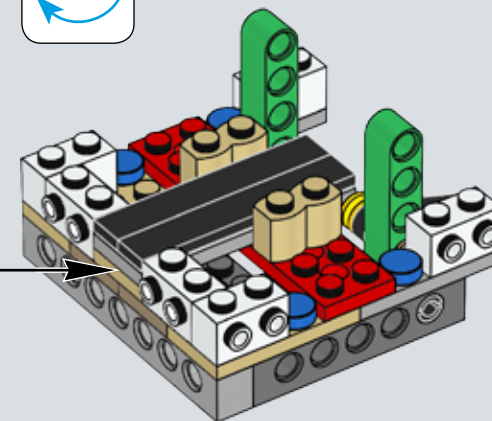
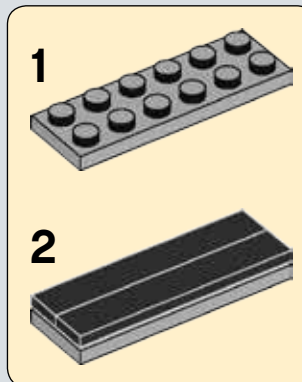
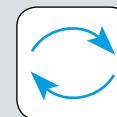

# 32

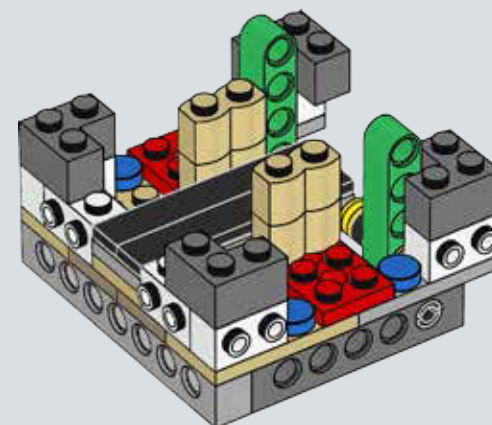

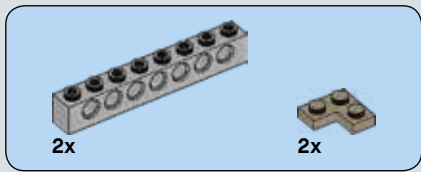

33

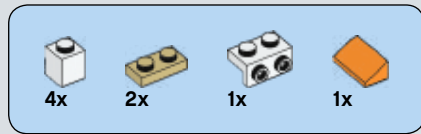
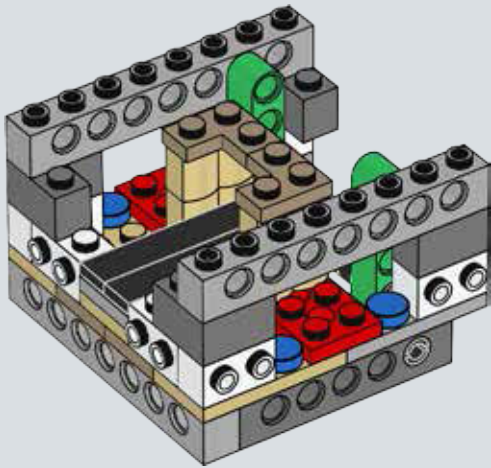

34

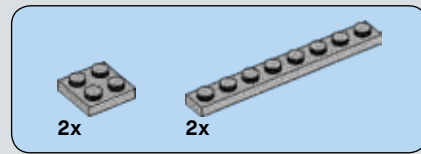
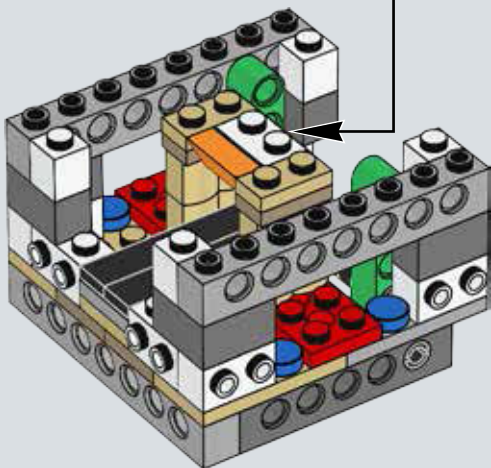
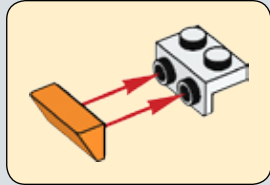

35

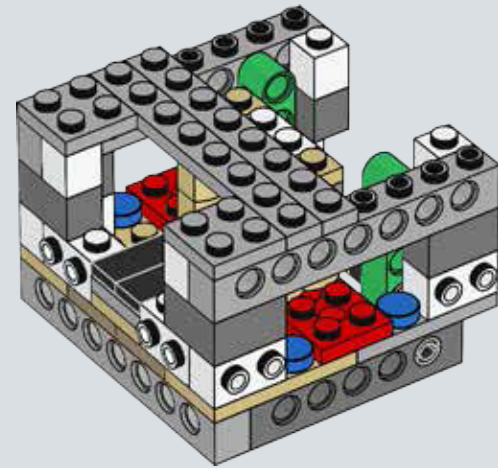

36

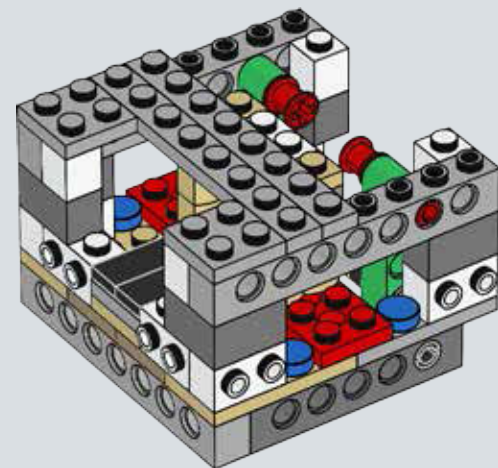

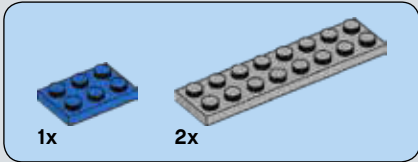
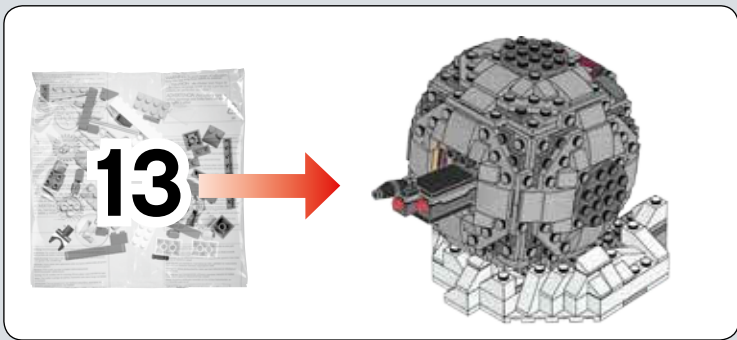

37

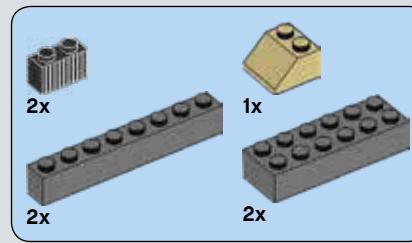
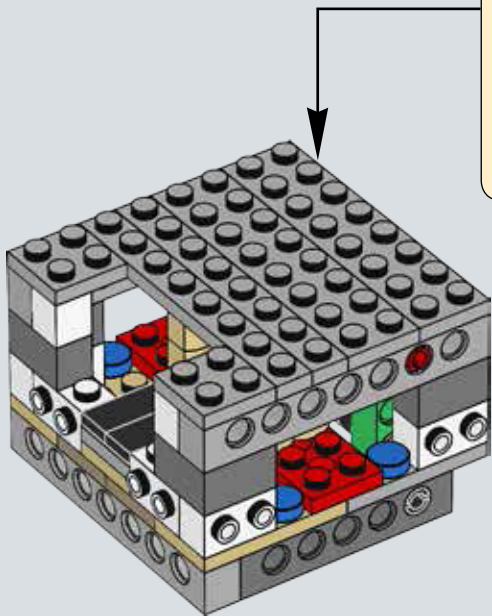
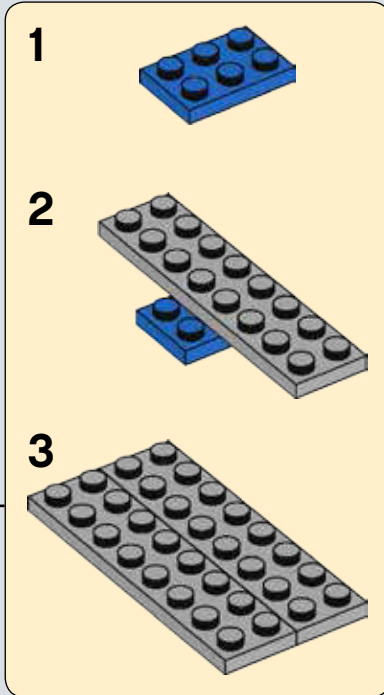

38

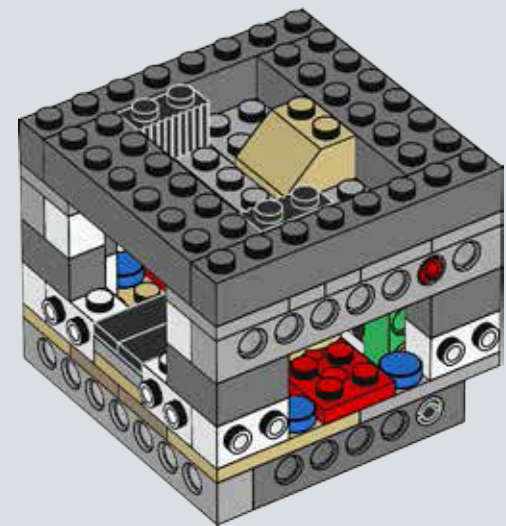





# 39

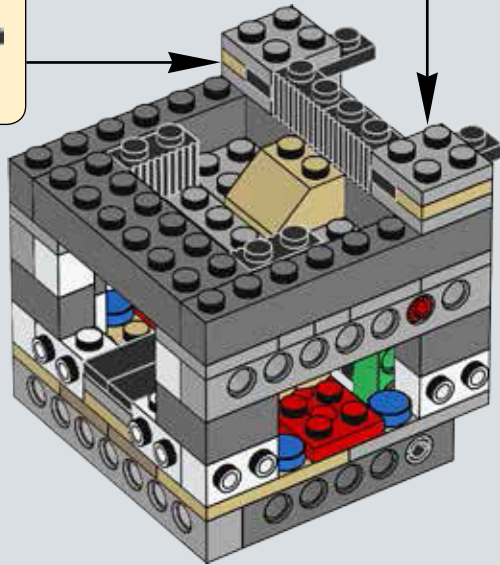
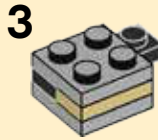
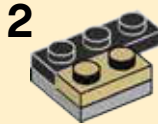

# 40

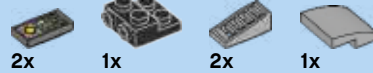
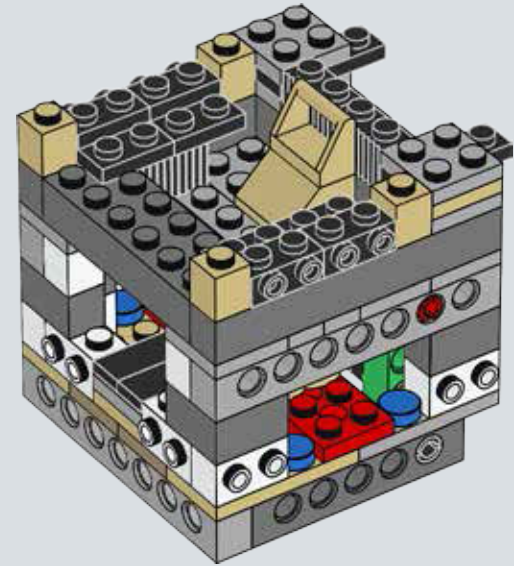

# 41

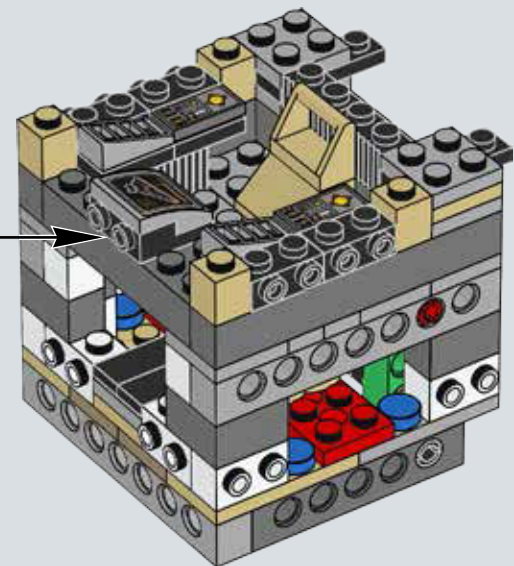
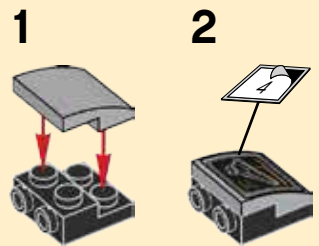



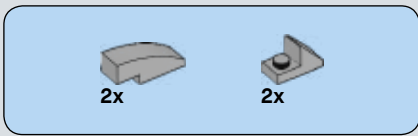

# 42

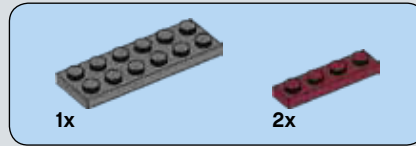
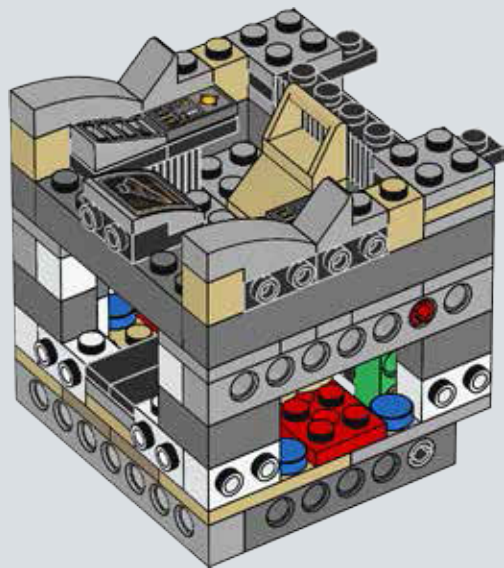

# 43

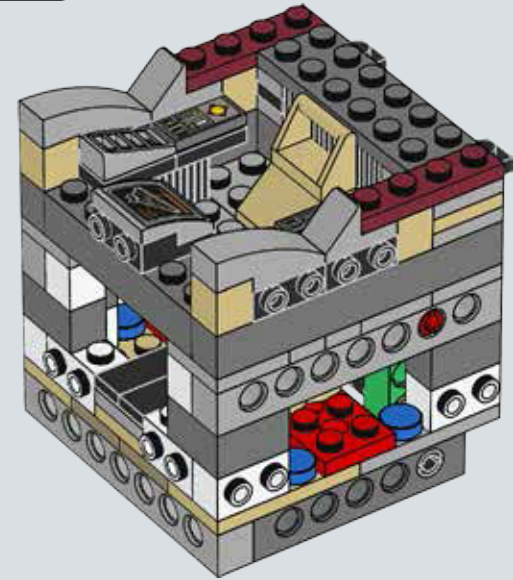

# 44

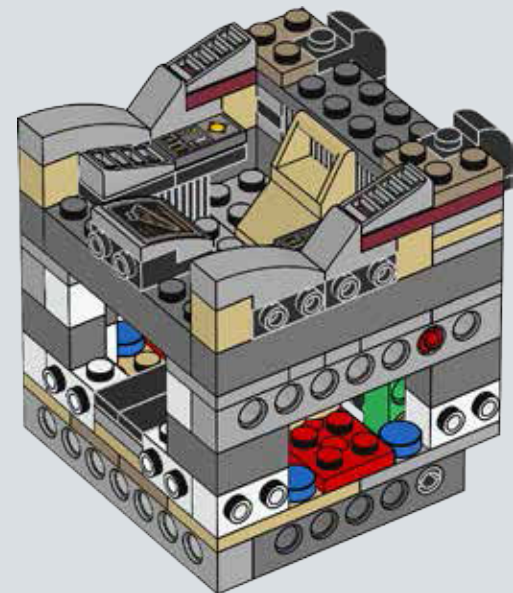



45

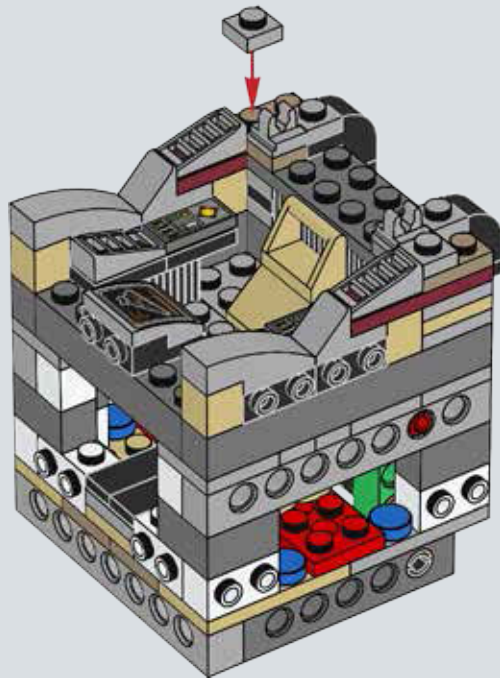

46

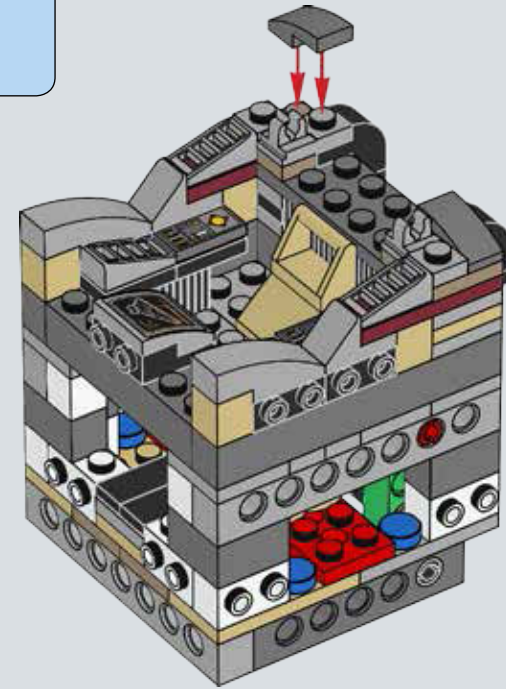

47

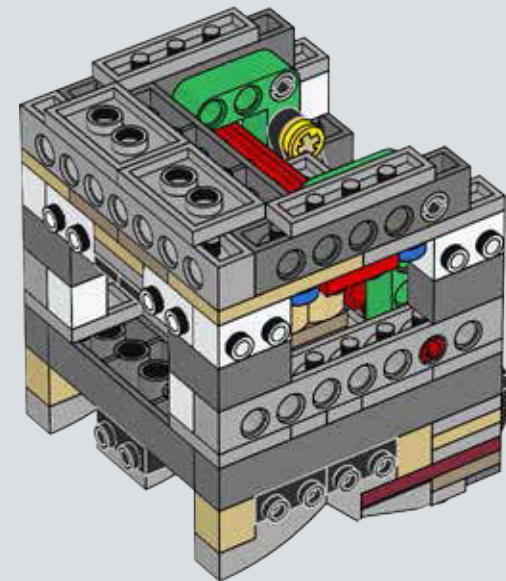
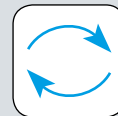

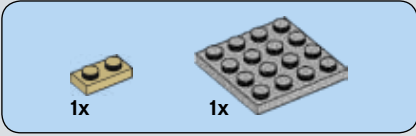
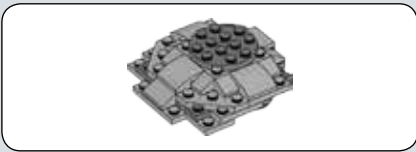

48

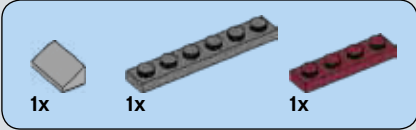
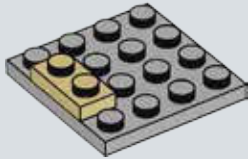

49

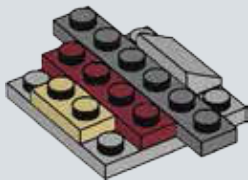

50

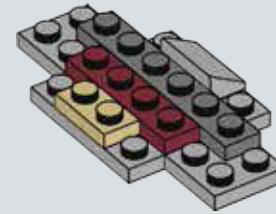

51

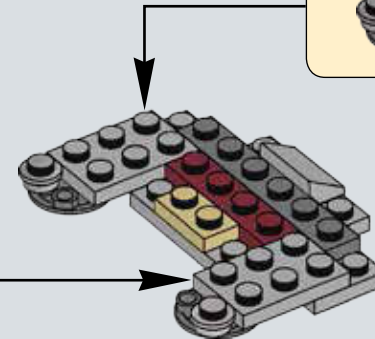
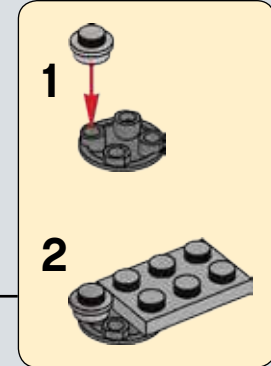
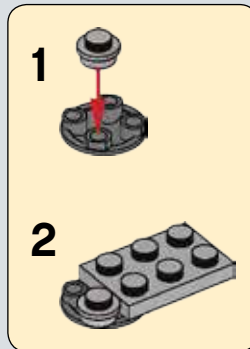



# 52

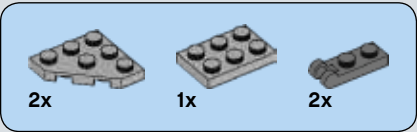
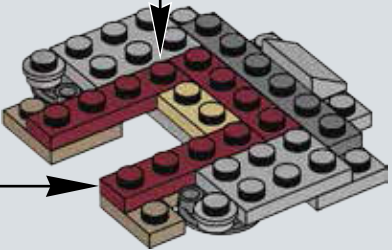
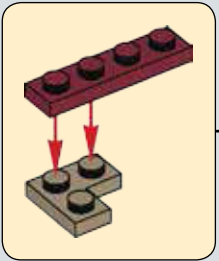
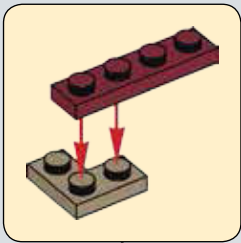

# 53

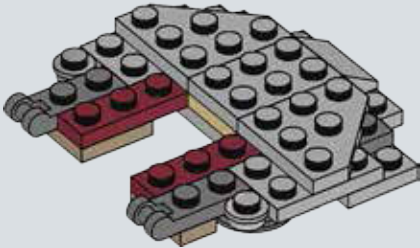

# 54

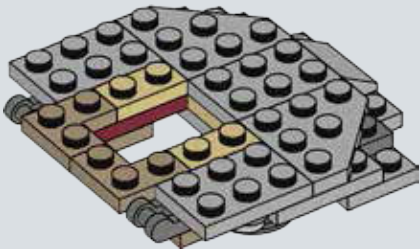



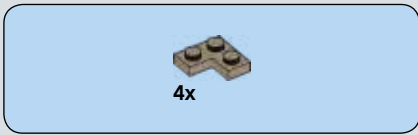

55

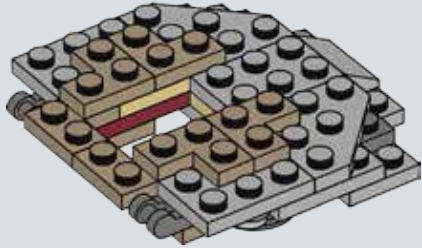

56

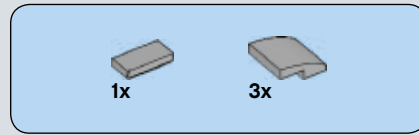
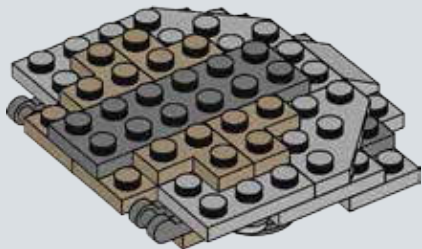

57

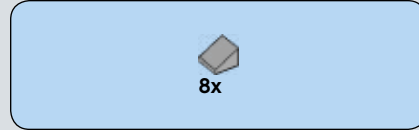
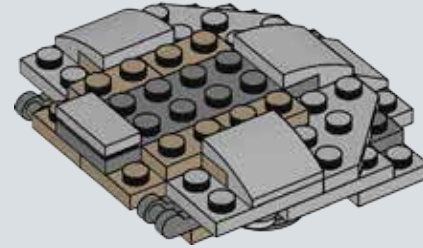

58

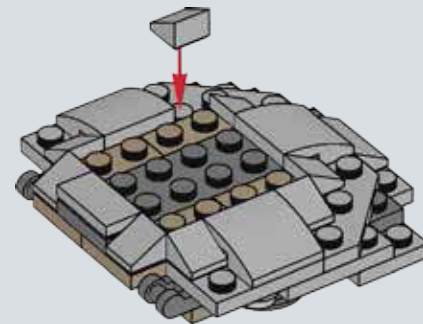

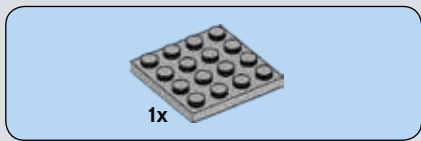

59

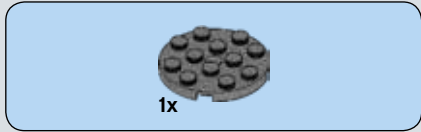
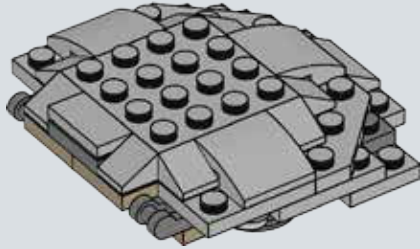

60

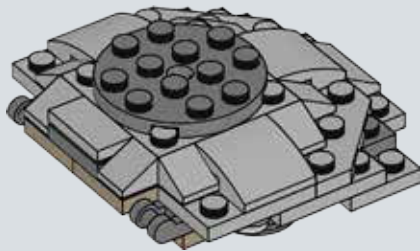

61

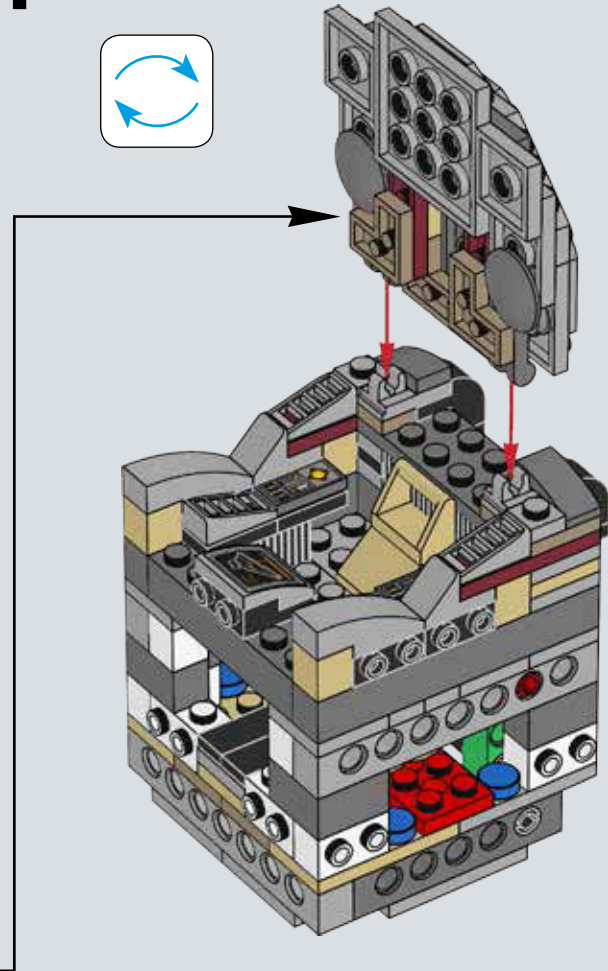
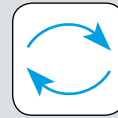

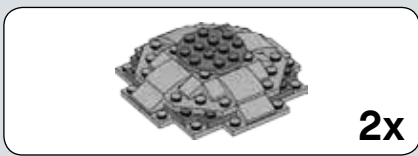

2x

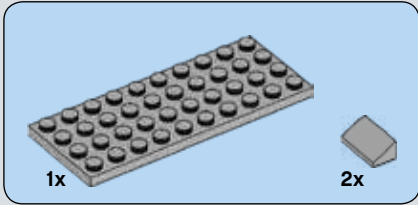

1x

2x

# 62

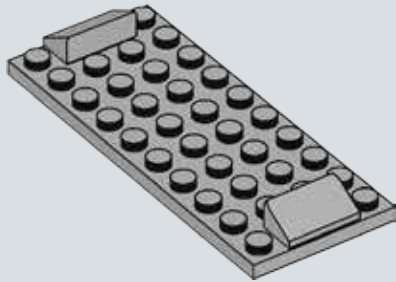

2x

2x

# 63

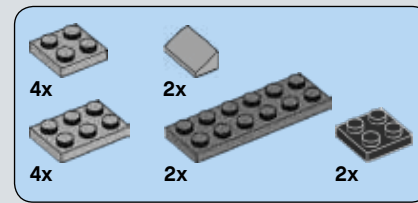
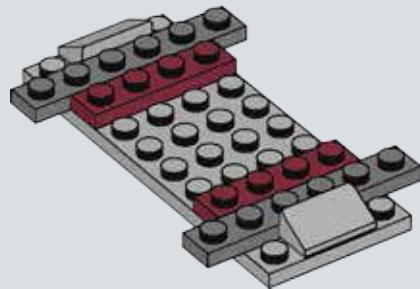

# 64

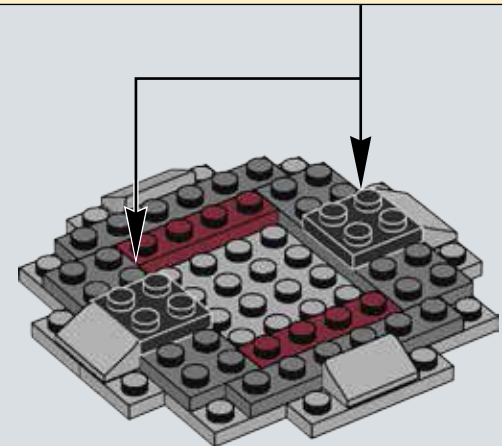
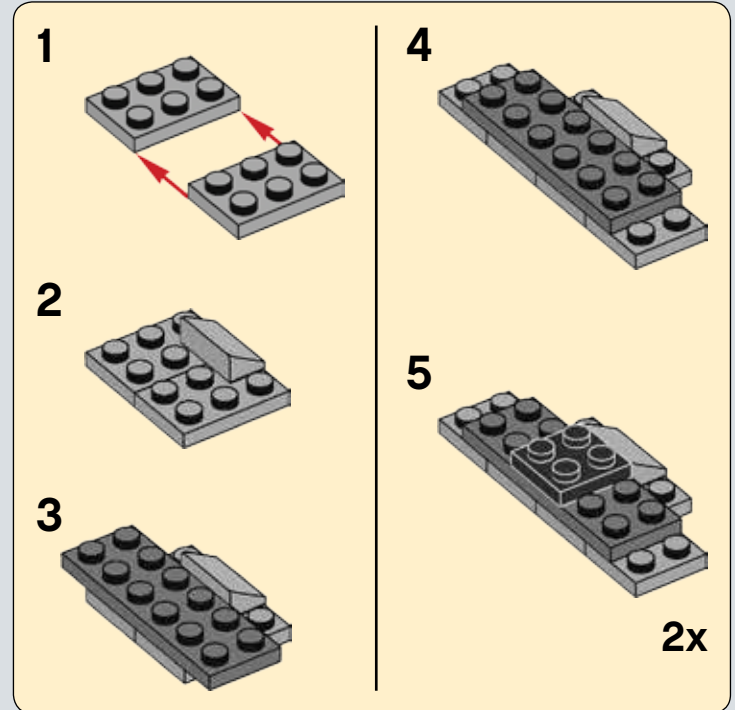

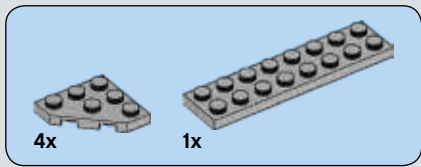

65

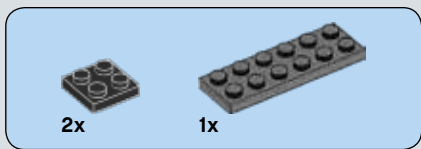
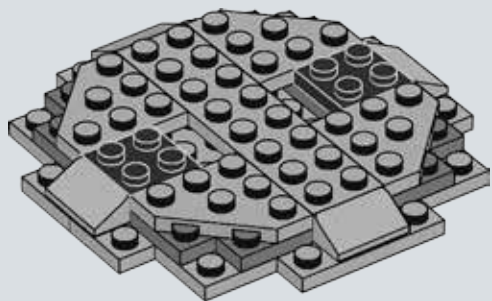

66

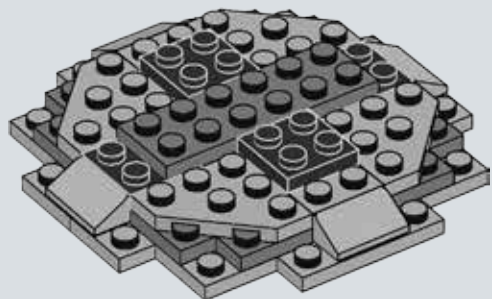

67

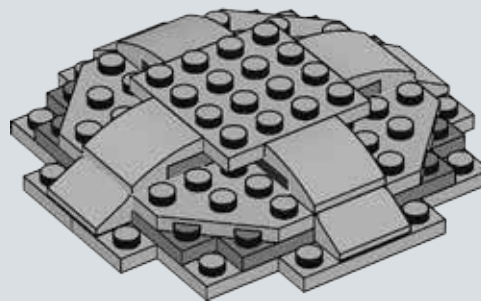





68

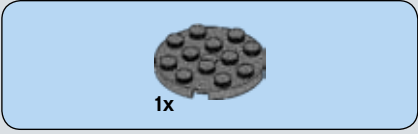
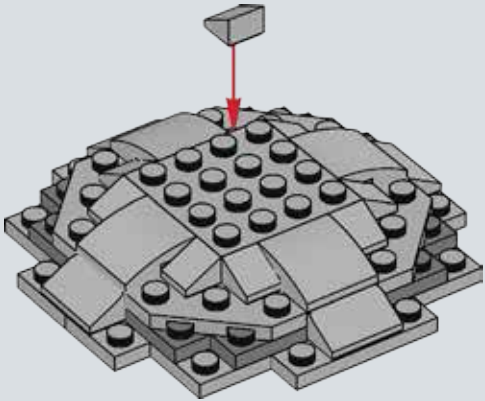

69

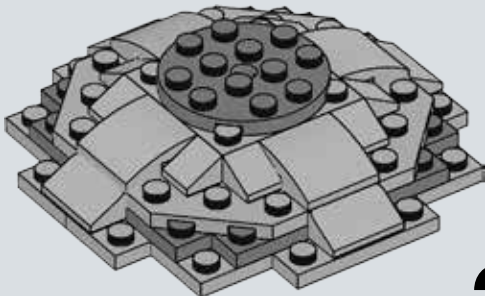

2x

70

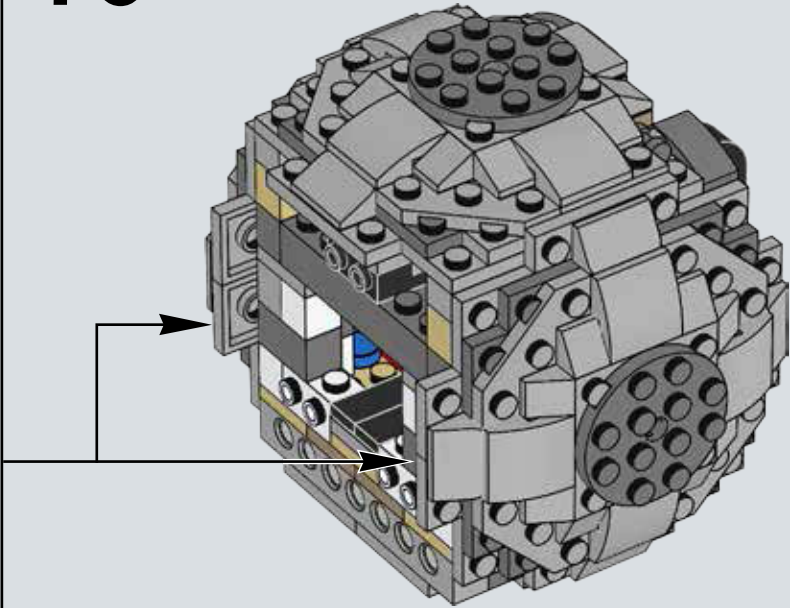

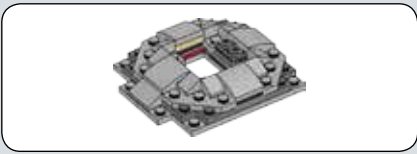

**71**

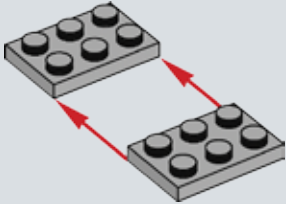

**72**

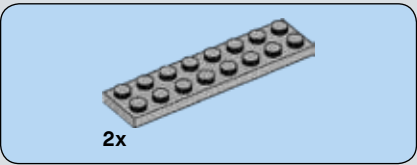
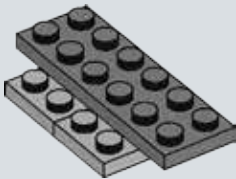

**73**

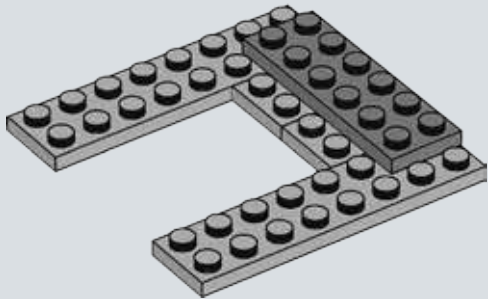

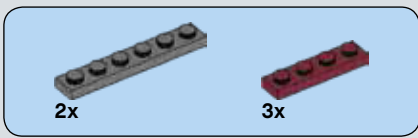

74

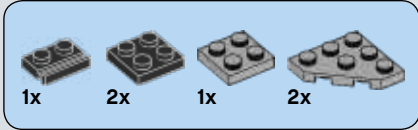
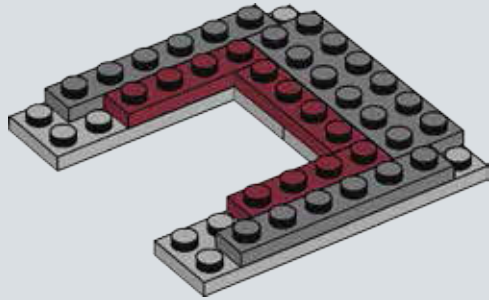

75

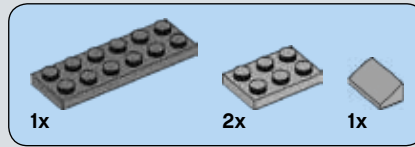
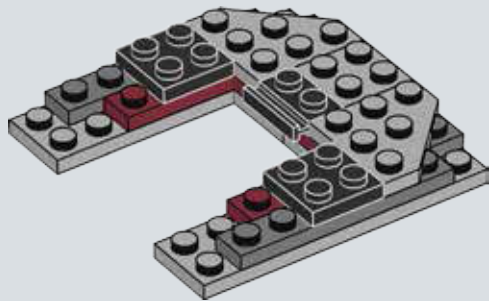

76

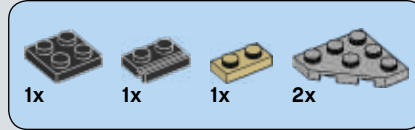
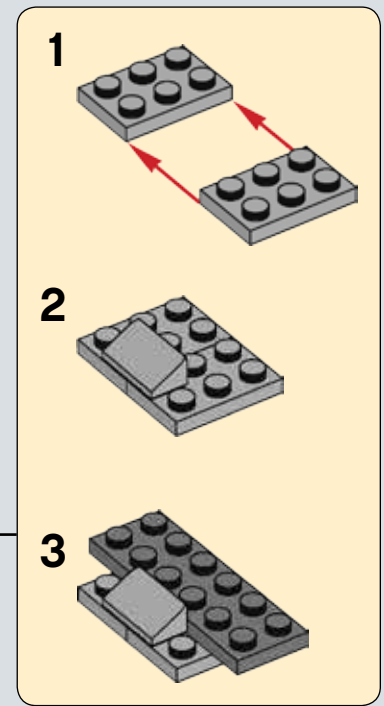
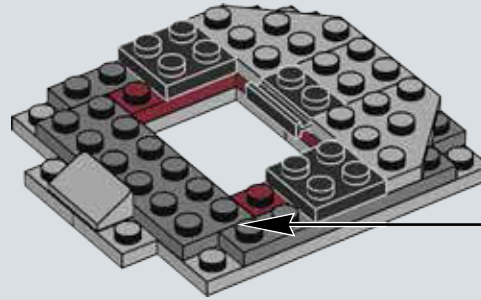

77

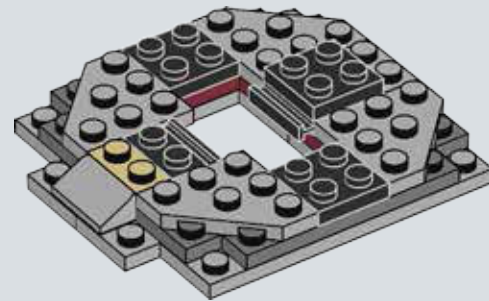



3x



8x

# 78

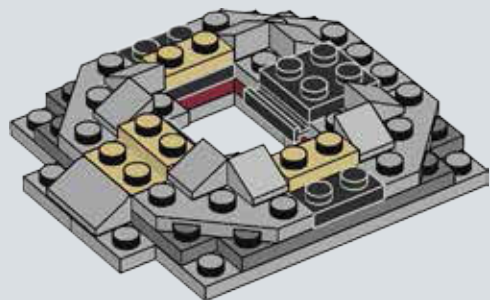

4x

# 79

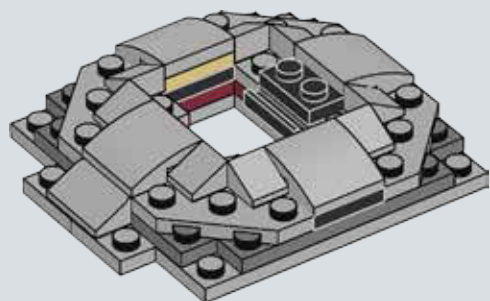

# 80

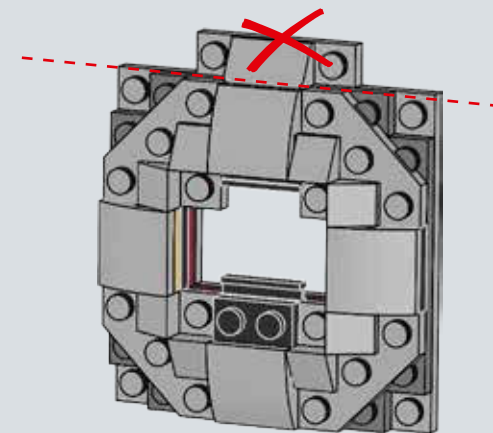
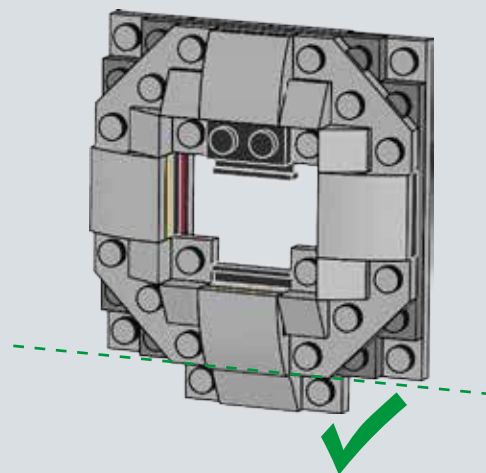
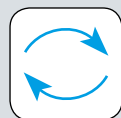

# 81

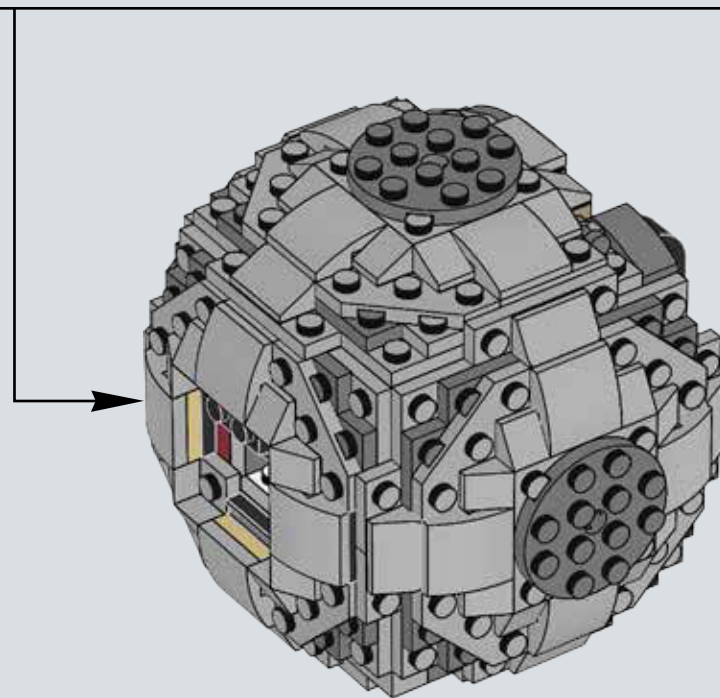



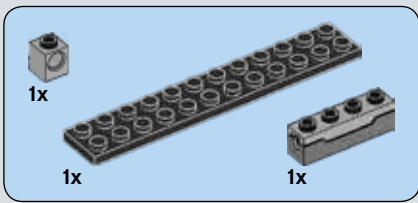

# 82

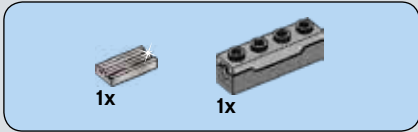
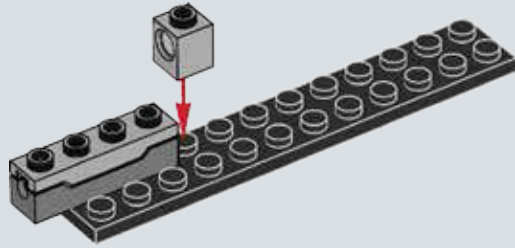

# 83

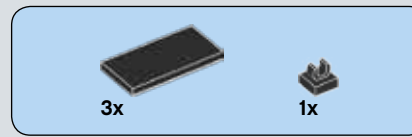
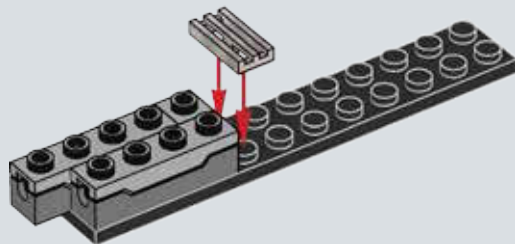

# 84

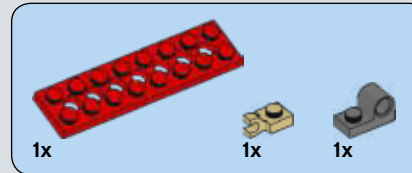
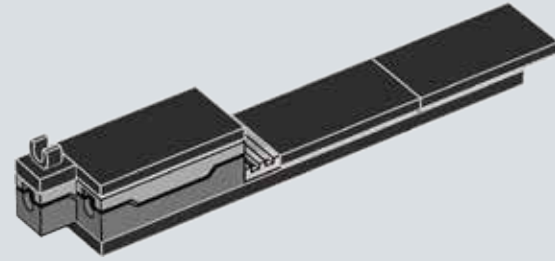

# 85

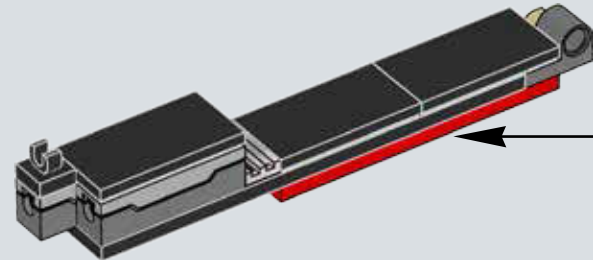
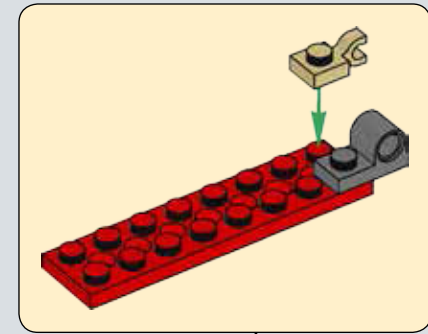

86

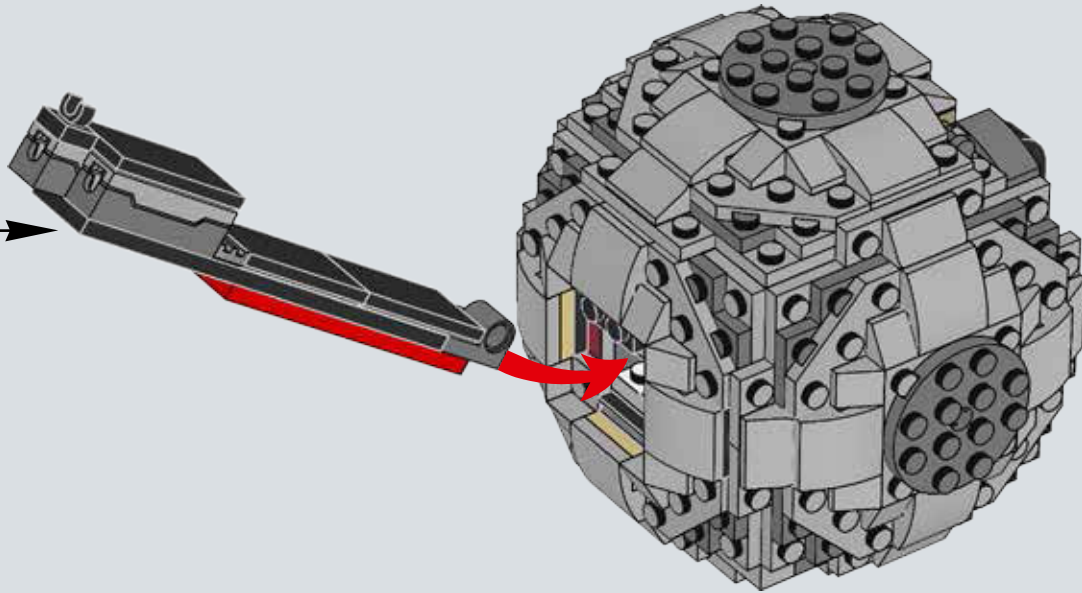

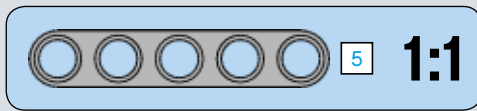
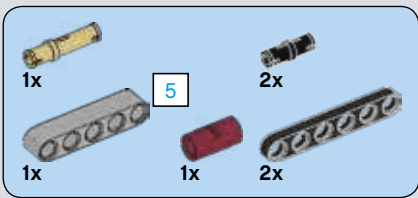

# 87

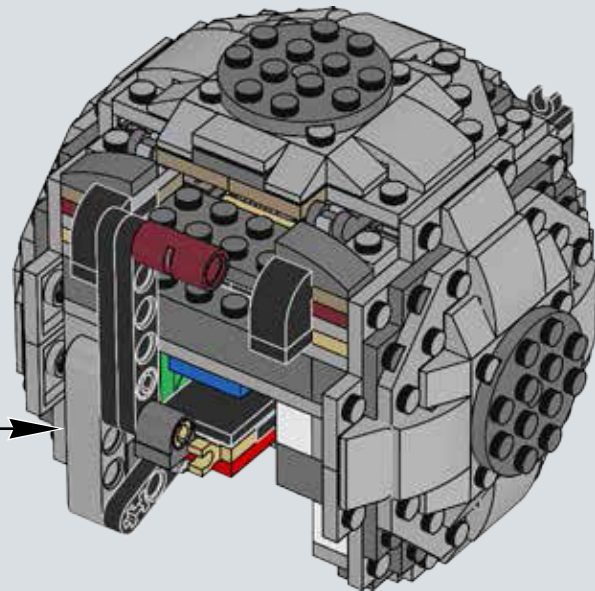
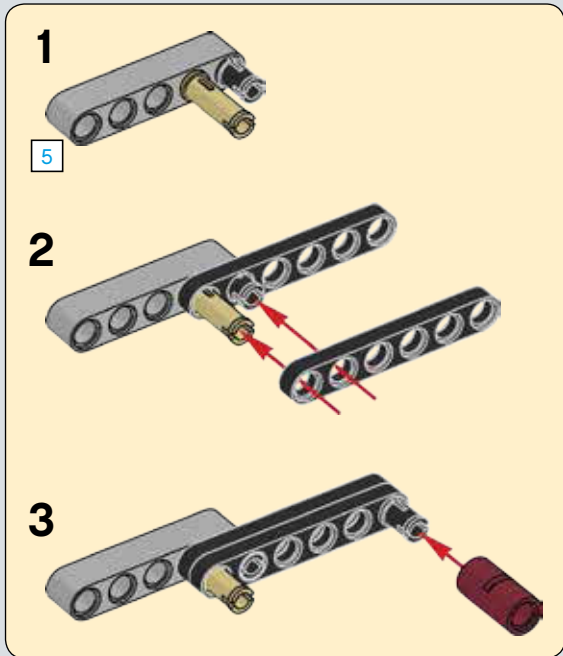
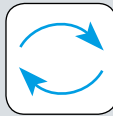

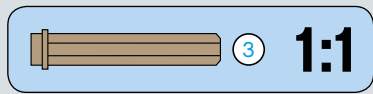
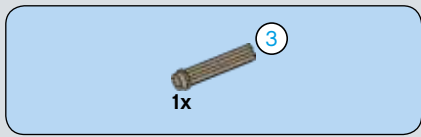

88

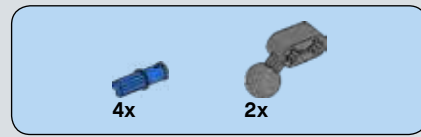
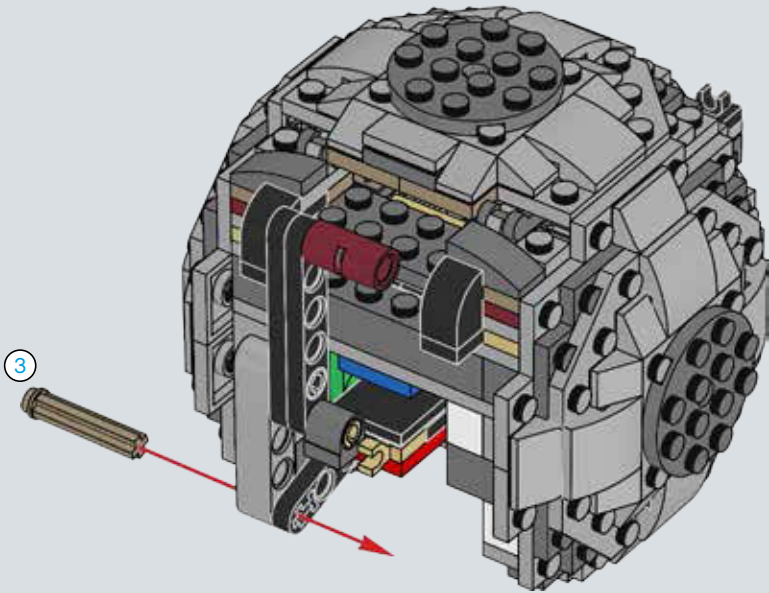

89

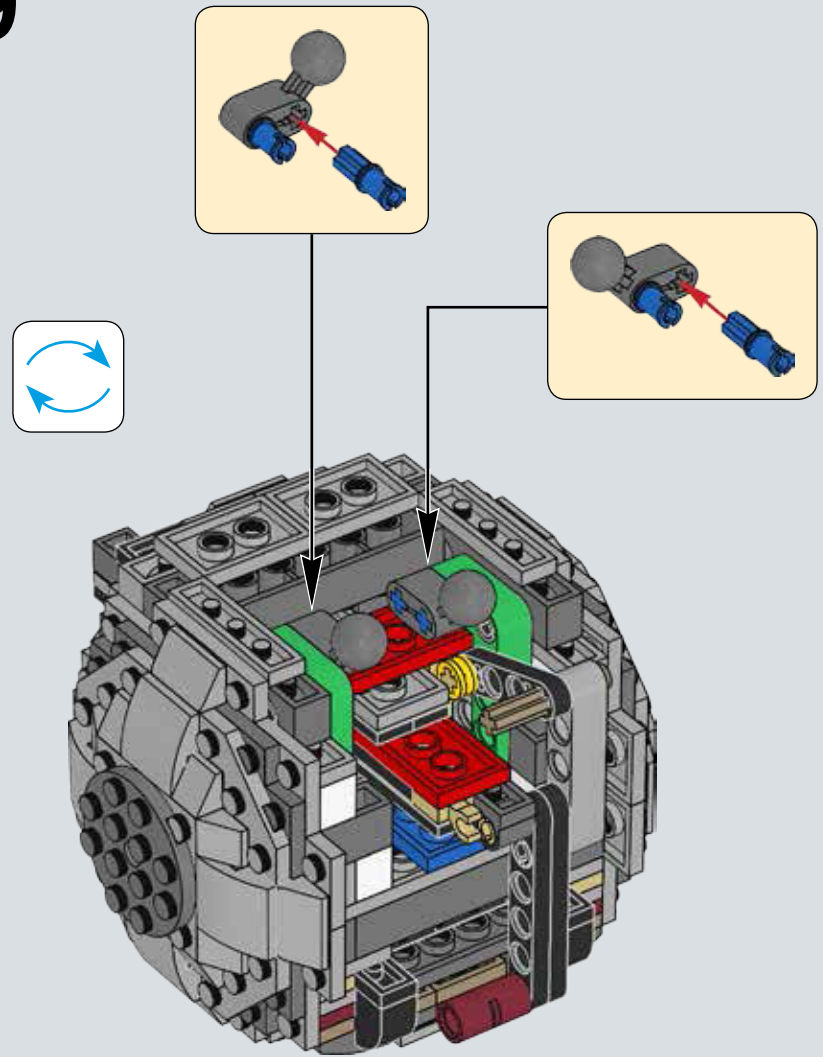





90

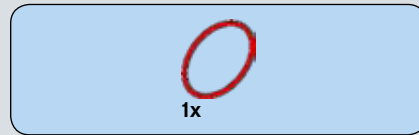
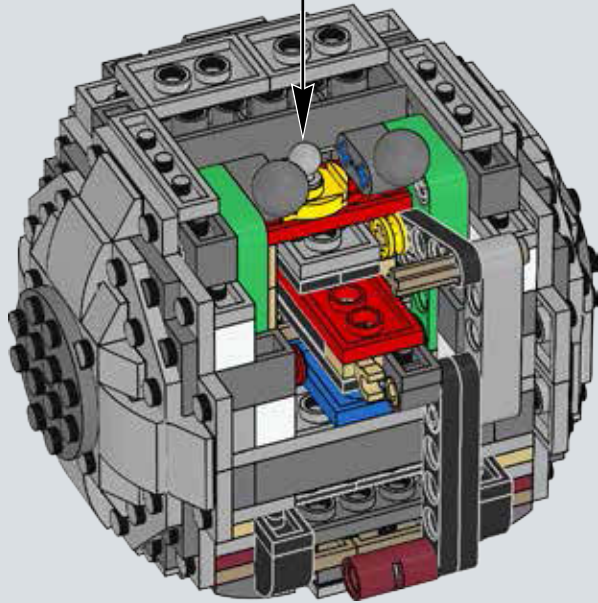
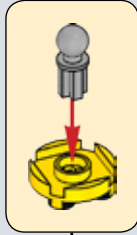

91

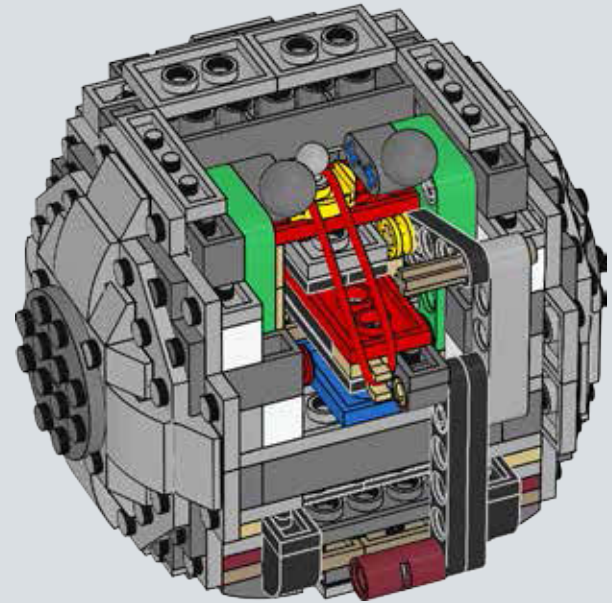



1x



1x

# 92

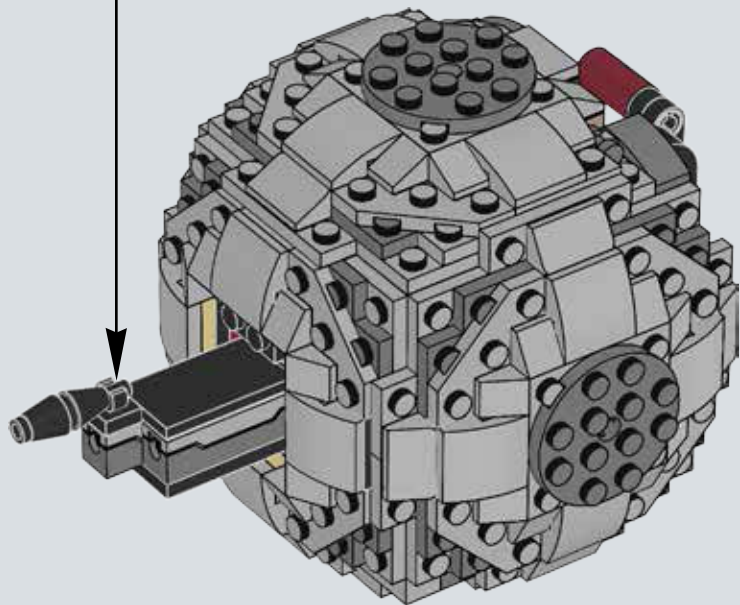
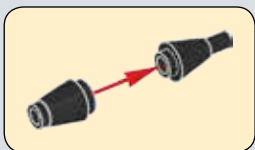
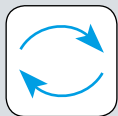

# 93

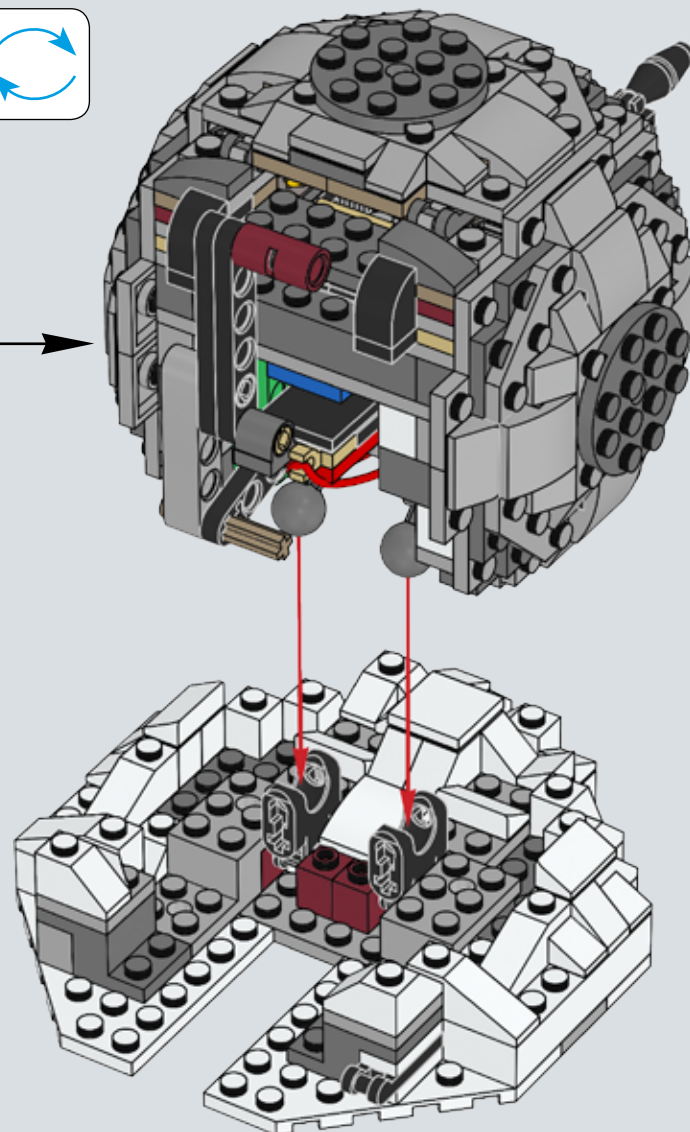
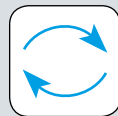

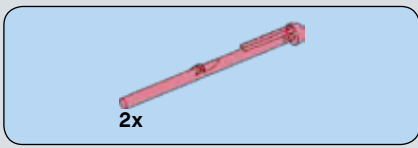

94

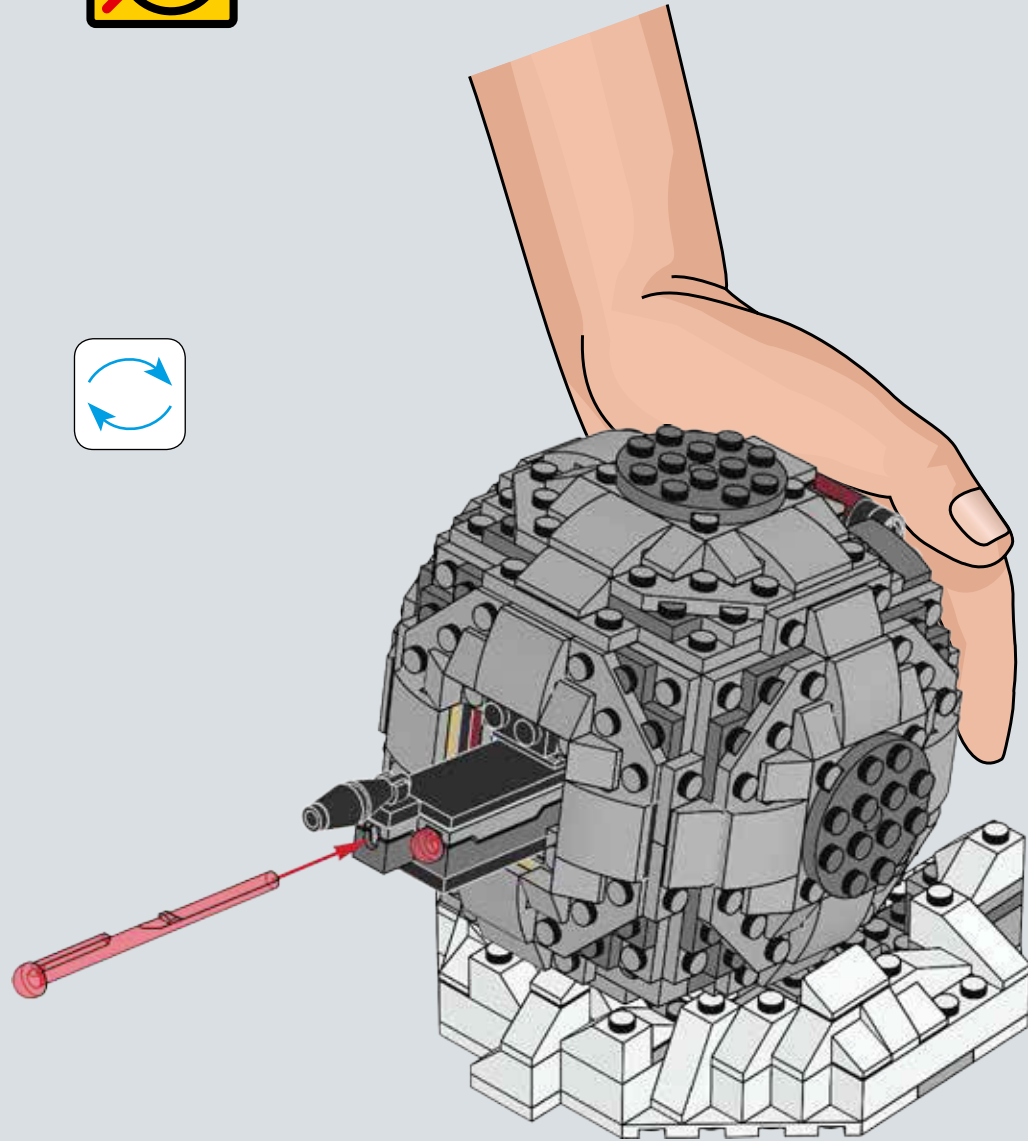
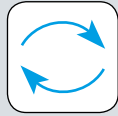

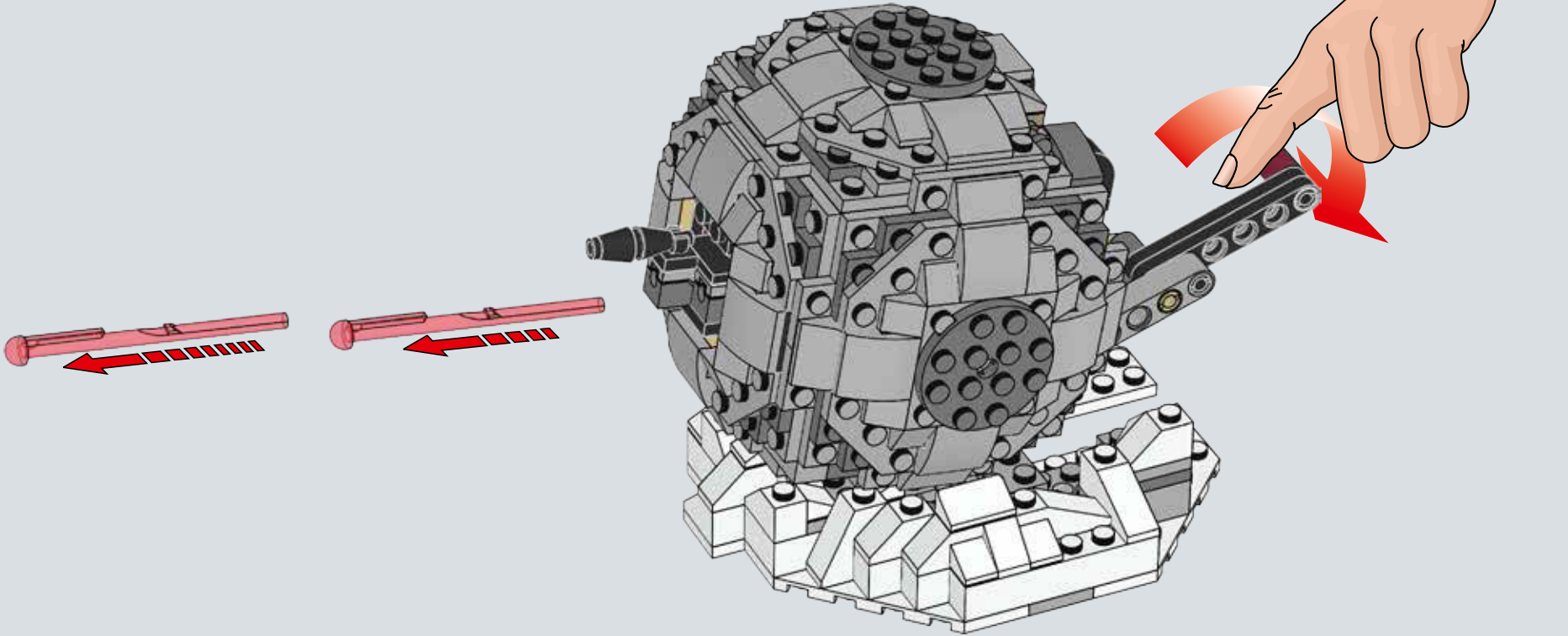



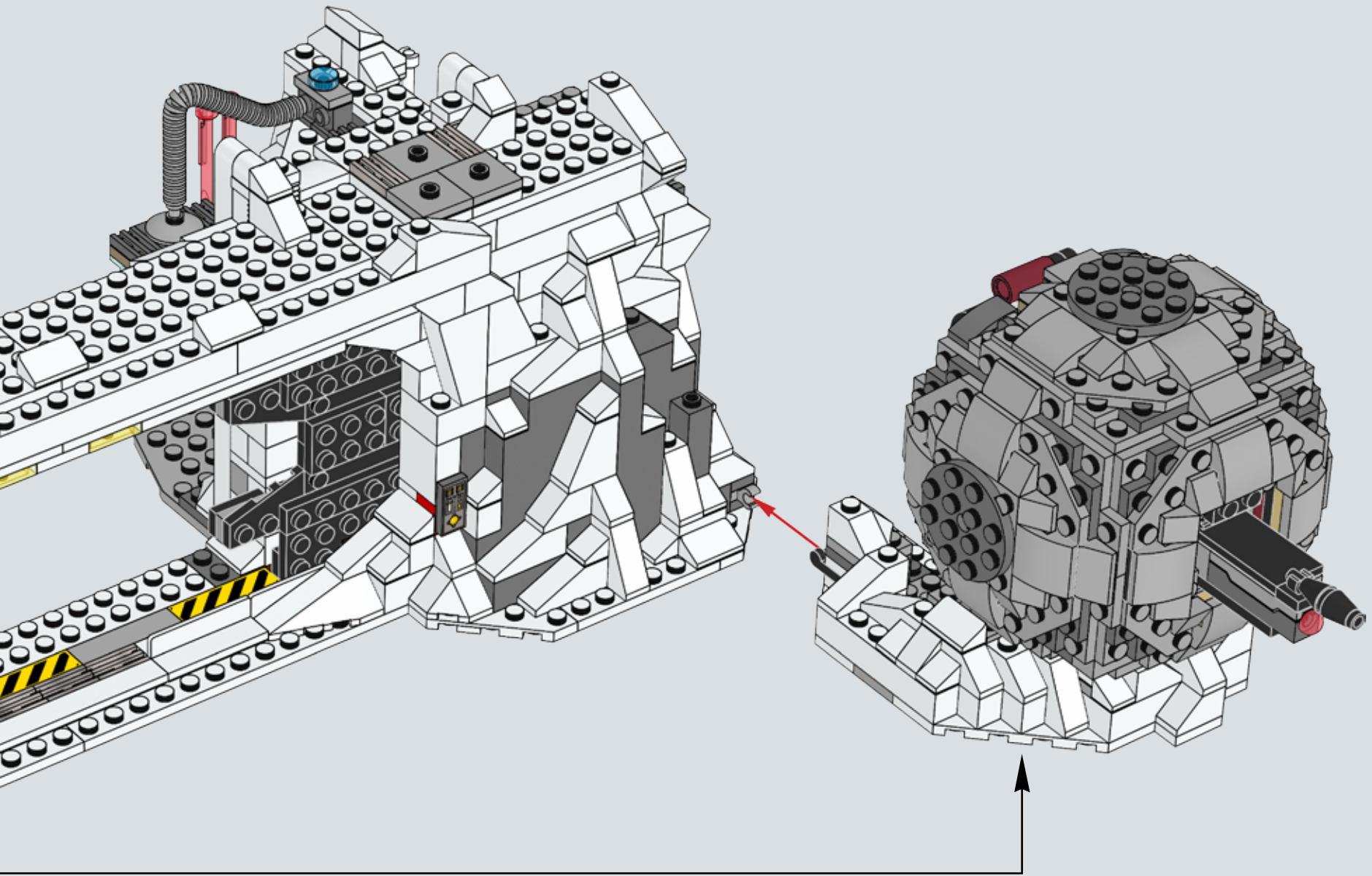

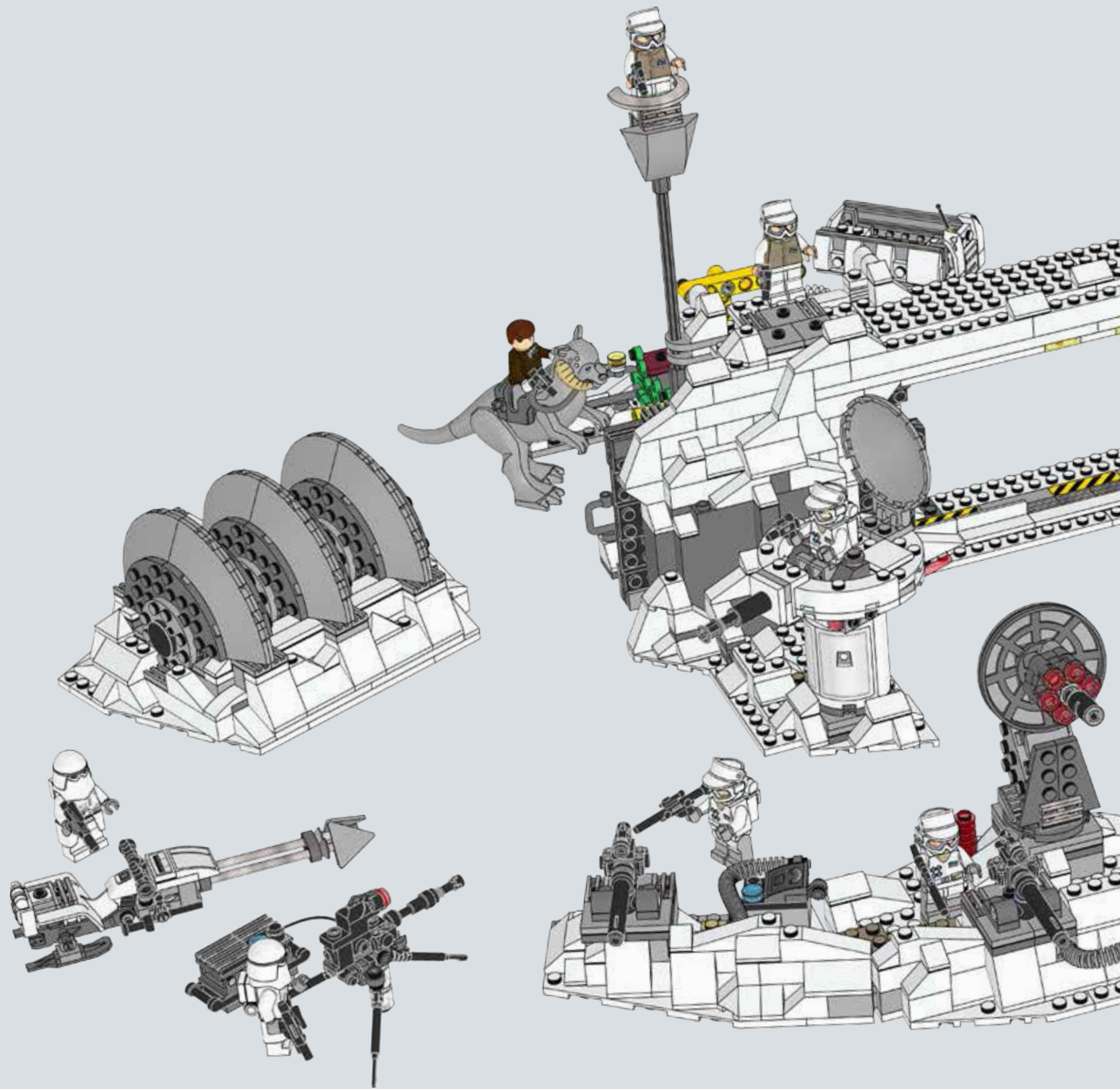



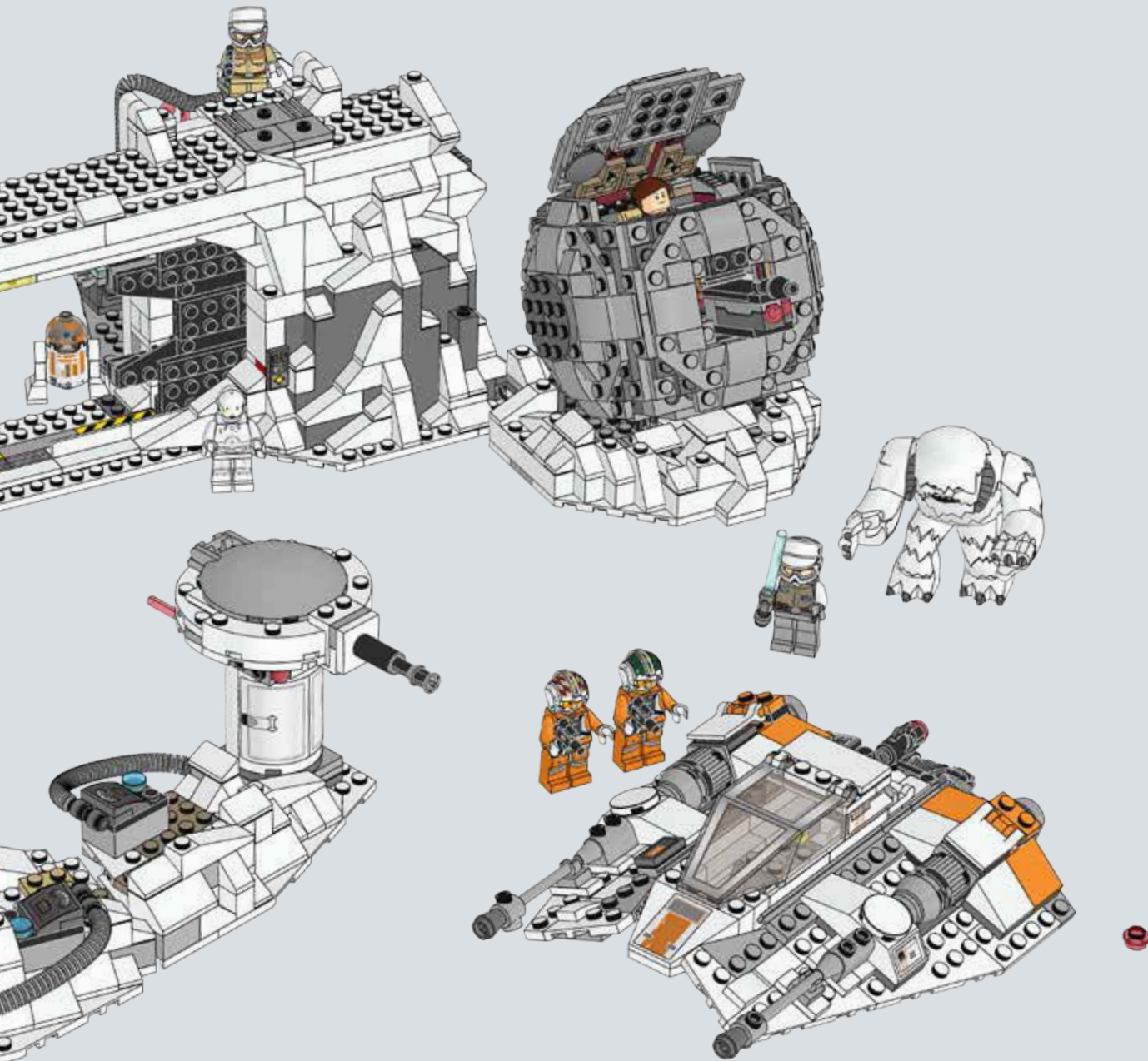

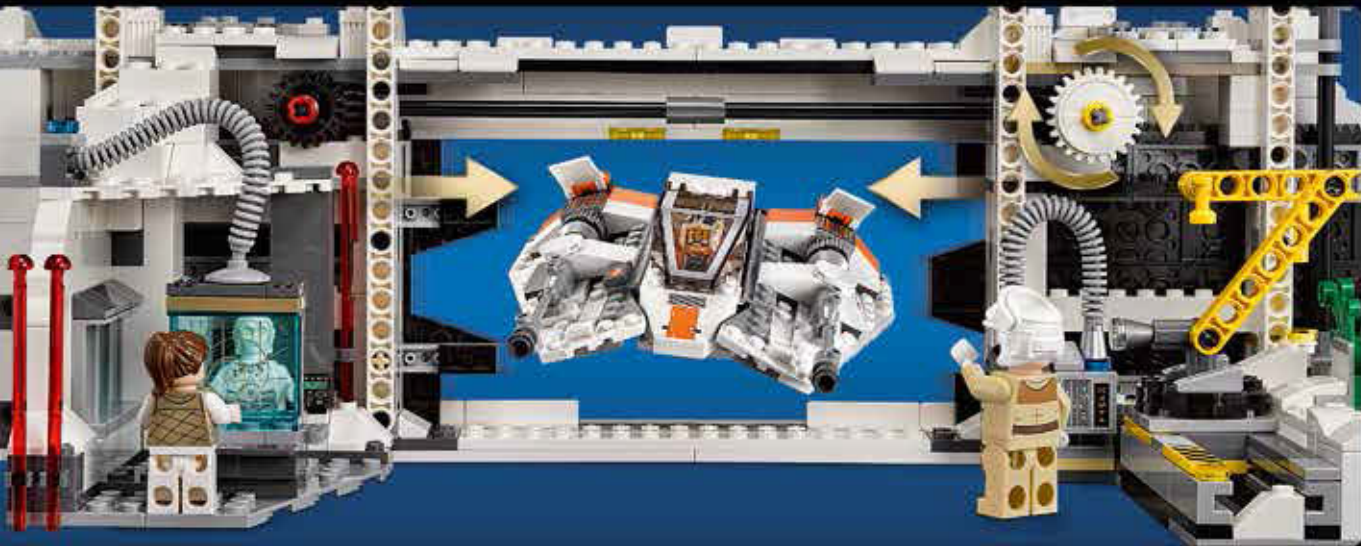





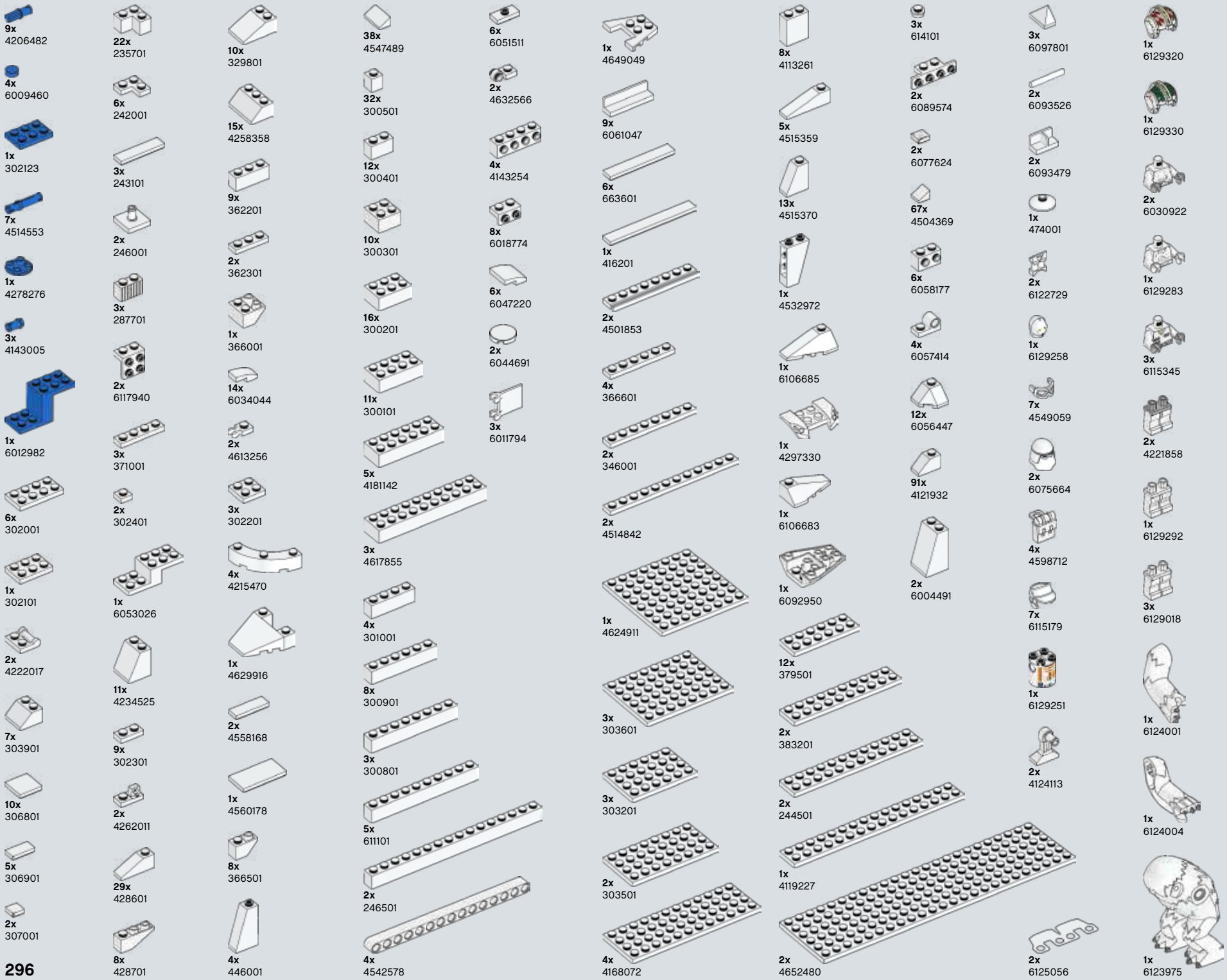



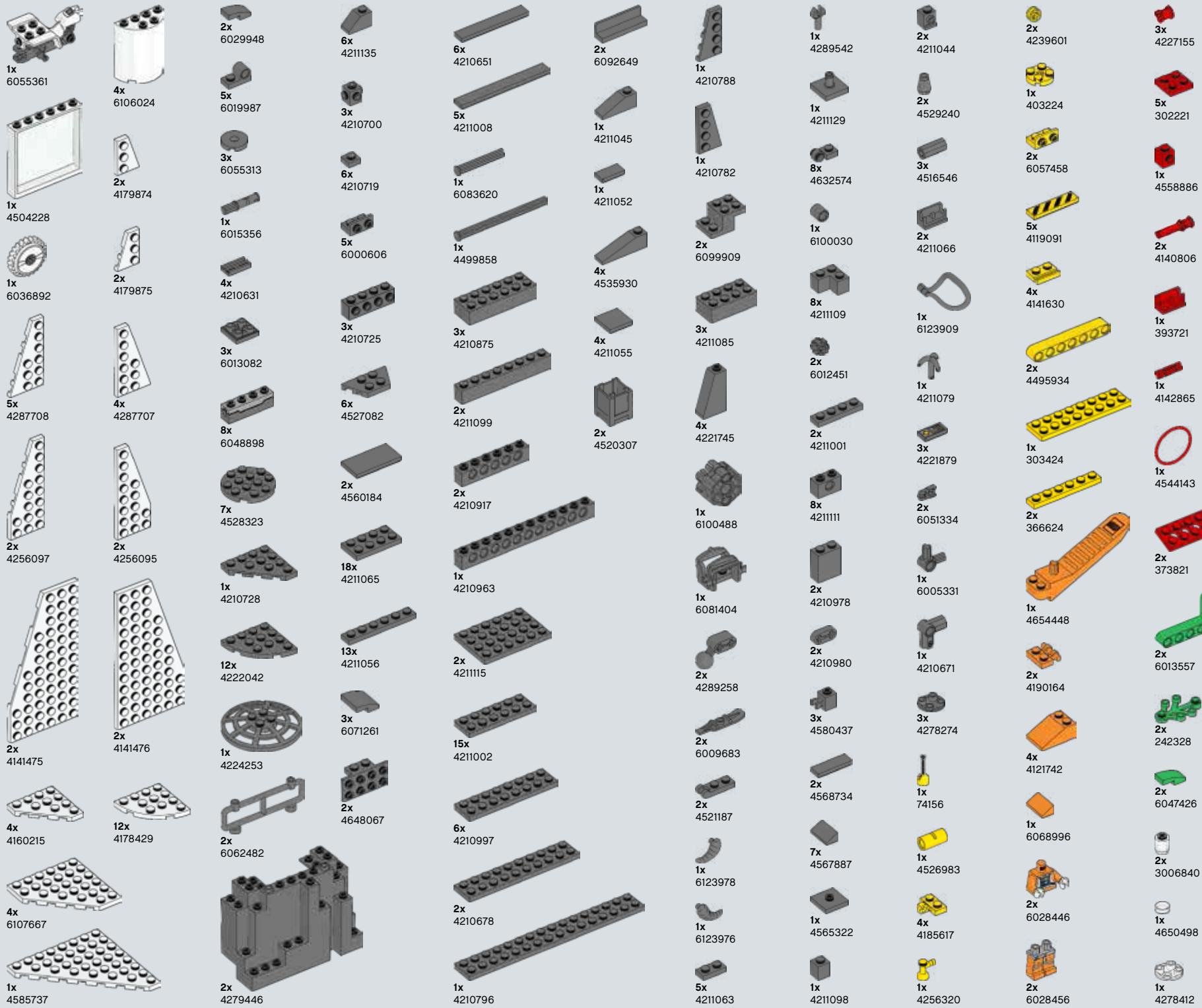



1x  
4295400

1x  
6051331

1x  
370526

2x  
370626

1x  
370726

3x  
370826

1x  
6096955

1x  
6123920

8x  
4100378

14x  
346026

2x  
303426

1x  
383226

2x  
244526

7x  
428226

1x  
6056234

2x  
6093977

2x  
4225201

2x  
4504382

1x  
4162235

4x  
4177431

1x  
6045912

2x  
4180508

3x  
6043130

2x  
4180536

1x  
4184169

5x  
6052126

1x  
4194008

1x  
4142236

1x  
6020193

1x  
6053077

6x  
4205760

2x  
6016172

3x  
4140801

20x  
4121715

2x  
4114634

2x  
4107761

3x  
6066102

6x  
6070695

9x  
241226

6x  
6088585

1x  
6092585

2x  
302026

2x  
663626

2x  
609126

2x  
486526

2x  
4610948

9x  
4609050

3x  
4598897

3x  
459926

2x  
4569407

3x  
4560182

2x  
4560174

1x  
4556158

1x  
4551168

1x  
6102734

1x  
407026

4x  
403226

2x  
4541191

1x  
4538456

2x  
4537551

1x  
393826

4x  
371026

2x  
249626

2x  
4223247

1x  
4529236

3x  
4526982

1x  
4523339

6x  
6117973

2x  
4515368

2x  
362326

1x  
4515350

2x  
4258354

4x  
287726

12x  
302326

1x  
4278359

17x  
302226

3x  
300426

5x  
302126

2x  
4498713

1x  
6123907

1x  
6013081

2x  
4666579

2x  
6092587

2x  
6013938

1x  
6021208

6x  
6024495

4x  
4218749

1x  
4107623

1x  
4514554

4x  
4113915

17x  
4113917

13x  
4114084

9x  
4118790

4x  
4112982

1x  
6123908

1x  
4114322

2x  
4114309

2x  
6116614

1x  
6129202

1x  
4520947

2x  
4613761

4x  
4539059

2x  
4539090

1x  
4539091

12x  
4539061

1x  
4124073

2x  
4594685

6x  
6061560

3x  
6129012

1x  
6129000

14x  
4550168

8x  
4528604

11x  
6035540

1x  
4267874

3x  
4550329

1x  
4246957

1x  
6031821

11x  
6054526

19x  
3005741

5x  
4260426

6x  
4646861

1x  
6129010

1x  
6030985

1x  
4499899

1x  
6129200

6x  
4296785

22x  
4619636

1x  
6121354

4x  
4633691

1x  
6123785

2x  
4611884

4x  
4585337

1x  
6093515

1x  
4211158

2x  
4194746

4x  
4650500



8x  
6100322

1x  
6060798

1x  
6051389

4x  
6051507

1x  
6051385

1x  
6112341

1x  
6058705

1x  
6127019

1x  
6128994

2x  
6118815

2x  
6077617

1x  
6129051

1x  
4634079

1x  
6057631

2x  
6021888

1x  
4611702

8x  
4211613

1x  
4211573

2x  
4535738

4x  
4211568

4x  
4211549

9x  
6092111

2x  
4211373

2x  
6089147

1x  
4211779

1x  
6097090

16x  
6102357

5x  
6015344

4x  
4211356

4x  
4211445

1x  
6019212

6x  
4515351

2x  
6015349

4x  
4243797

4x  
6045718

2x  
6097092

1x  
4211796

12x  
6063878

2x  
6102575

2x  
6030989

3x  
4211442

1x  
4611705

5x  
6056596

2x  
4211425

2x  
4514846

2x  
4211498

2x  
4222019

7x  
4211452

6x  
4211406

3x  
4211360

6x  
4662161

2x  
4211402

2x  
4211401

2x  
4211616

1x  
4211617

4x  
4211353

1x  
4227657

10x  
4211414

1x  
6129028

1x  
4211413

1x  
4211512

33x  
4521921

4x  
6071229

1x  
4211504

2x  
4251163

1x  
4211370

1x  
6123905

1x  
6123906

1x  
6123910

1x  
6123910



25x  
4211535

1x  
4646512

1x  
4646513

6x  
4654577

9x  
4654580

2x  
4211388

2x  
4211394

2x  
4211886

2x  
4211881

1x  
4233493

3x  
6115357

1x  
4211807

2x  
4650645

7x  
4211440

8x  
4211436

4x  
4515341

3x  
4211428

5x  
6028324

14x  
4211350

2x  
4211461

2x  
4593679

2x  
4594238

1x  
4211375

6x  
4598526

4x  
4211383

1x  
4211632

1x  
4211651

2x  
6028811

2x  
6066097

1x  
4533772

1x  
4211488

11x  
4211476

2x  
6011459

1x  
4211470

20x  
4211361

2x  
4211794

2x  
4211791

23x  
4211396

2x  
4211419

19x  
4211397

2x  
4211760

21x  
6126082

2x  
4211758

11x  
4568637

1x  
6093869

1x  
4211679

2x  
6093859

8x  
4211386

3x  
4585429

2x  
4211399

4x  
4211398

1x  
4211376

Customer Service

Kundenservice

Service Consommateurs

Servicio Al Consumidor

LEGO.com/service or dial



: 00800 5346 5555

: 1-800-422-5346

# WIN

GO TO [WWW.LEGO.COM/PRODUCTFEEDBACK](http://WWW.LEGO.COM/PRODUCTFEEDBACK) AND GIVE US YOUR SHORT **FEEDBACK** ABOUT THIS LEGO® SET FOR A CHANCE TO WIN A COOL LEGO PRIZE.

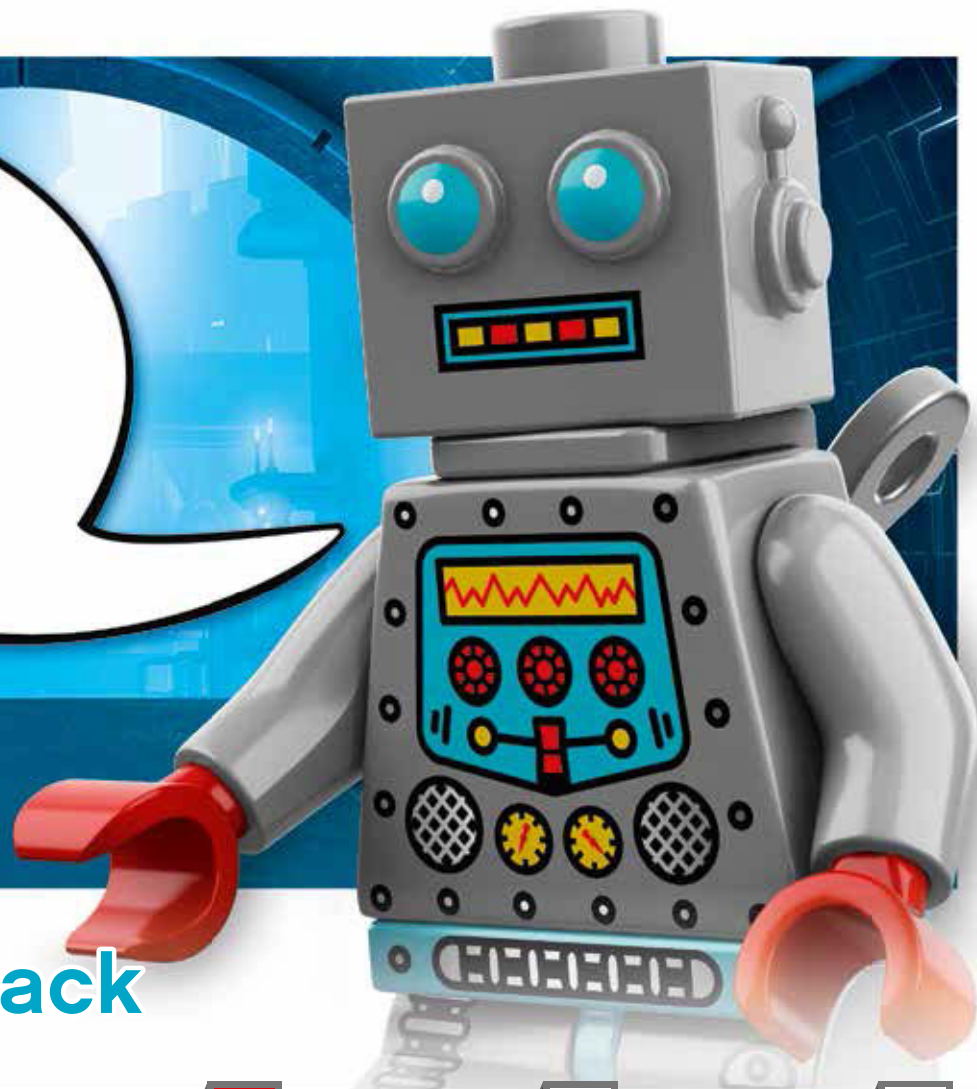

## LEGO.com/productfeedback

### GEWINNE



Erzähle uns auf [www.LEGO.com/productfeedback](http://www.LEGO.com/productfeedback)

etwas über die Erfahrungen, die du mit diesem LEGO® Set gemacht hast, und sichere dir die Chance auf einen coolen LEGO Preis!

### GAGNE



Rends-toi sur [www.LEGO.com/productfeedback](http://www.LEGO.com/productfeedback)

et donne-nous quelques commentaires sur ce produit LEGO® pour avoir une chance de gagner un prix LEGO !

### GANAN



Visita [www.LEGO.com/productfeedback](http://www.LEGO.com/productfeedback)

y envíanos tu opinión acerca de este set LEGO®. ¡Participarás en el sorteo de un premio LEGO!

### 获取奖品



登录 [www.LEGO.com/productfeedback](http://www.LEGO.com/productfeedback)

给出关于此乐高®套装的简短反馈，就有机会获得炫酷乐高奖品

### 경품 당첨 기회



[www.LEGO.com/productfeedback](http://www.LEGO.com/productfeedback)

페이지로 이동하여 이 레고® 세트에 대한 간단한 피드백을 보내 주시고 멋진 레고 경품을 탈 수 있는 기회도 잡으십시오

### ЗАПОЛНИ АНКЕТУ И ПОЛУЧИ ПРИЗ



Перейди по ссылке [www.LEGO.com/productfeedback](http://www.LEGO.com/productfeedback)

ответь всего на несколько вопросов об этом наборе LEGO®, и у тебя появится шанс выиграть замечательный приз от компании LEGO.