



# RACERS

9094



1

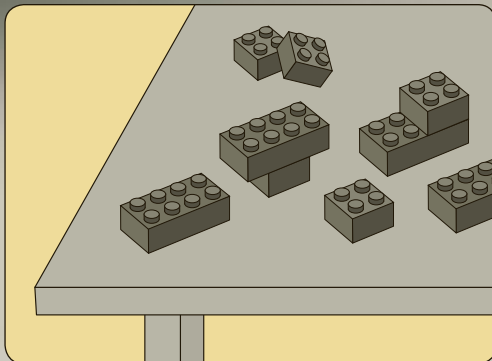
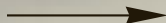

2

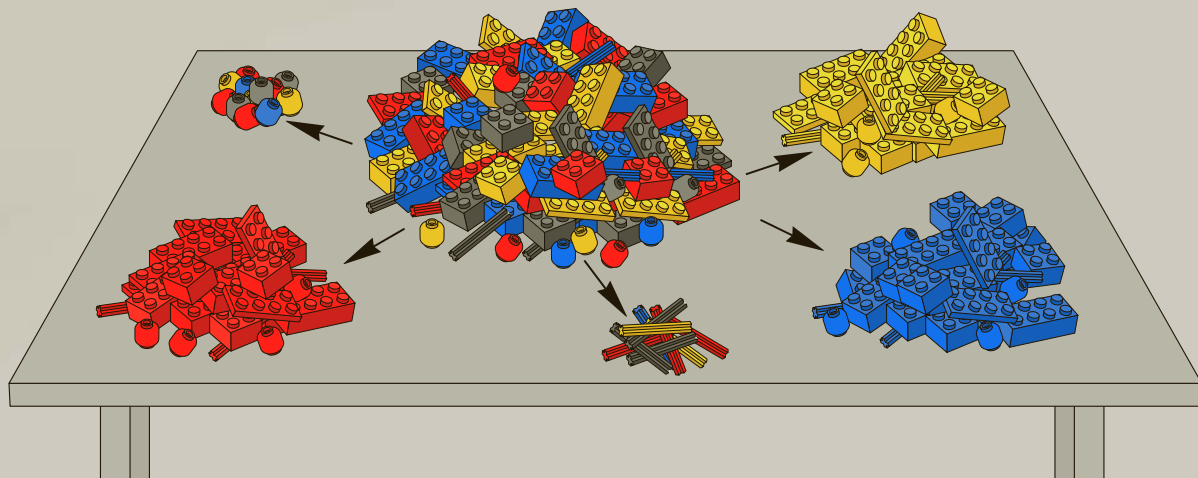

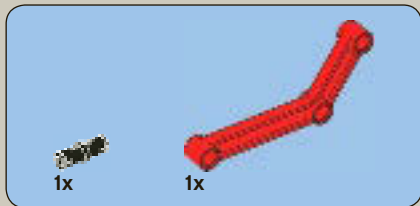

1

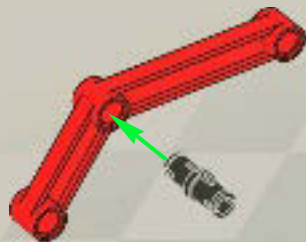

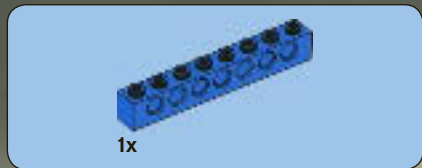

2

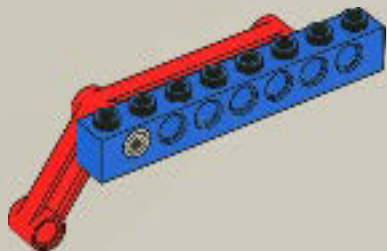

3

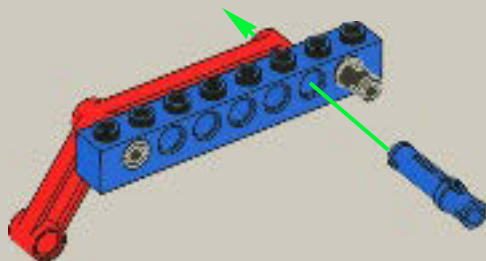

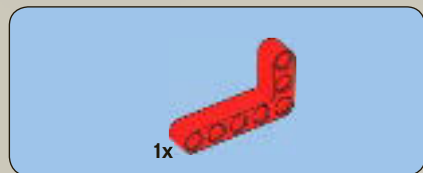

4

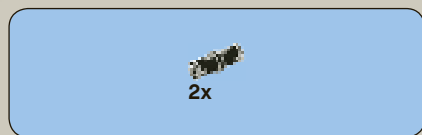
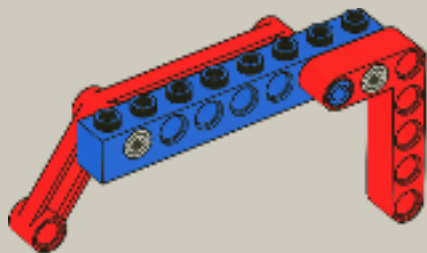

5

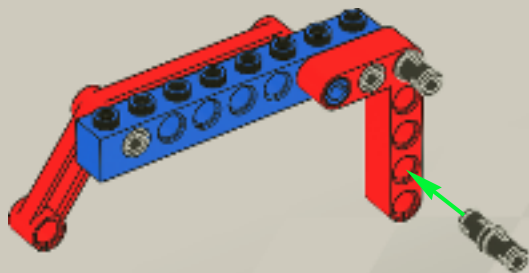



6

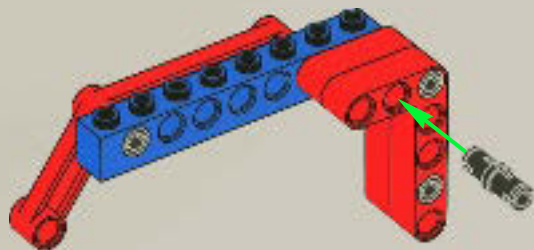

6

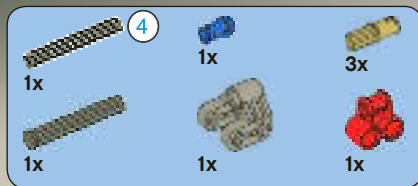

7

1

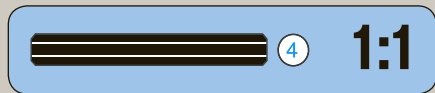
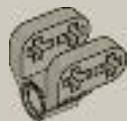

**2**

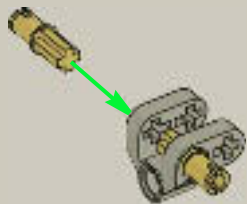

**3**

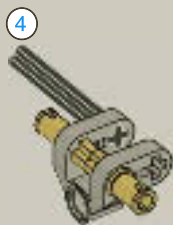

**4**

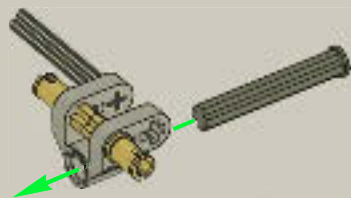

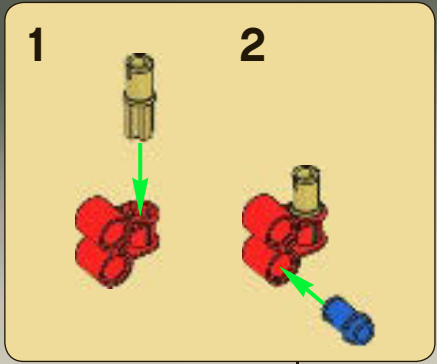

**5**

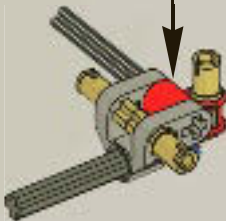

**6**

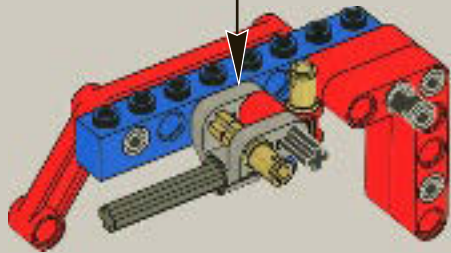
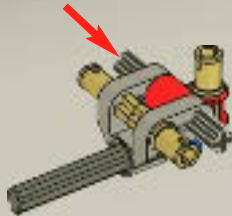





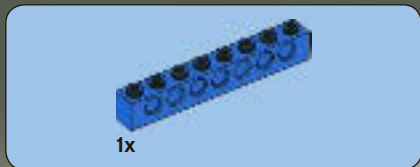

8

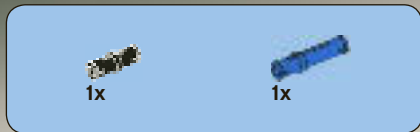
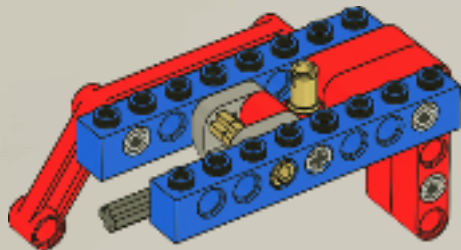

9

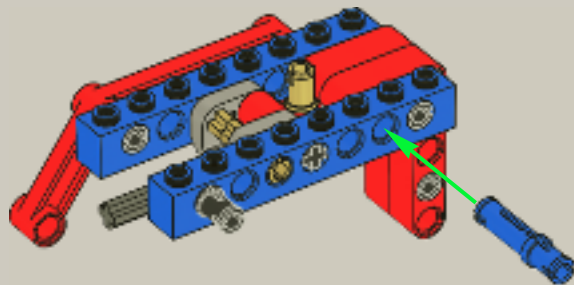

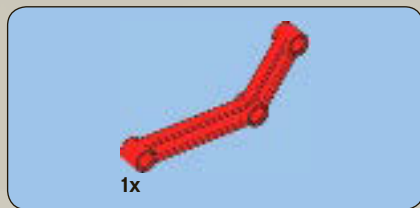

10

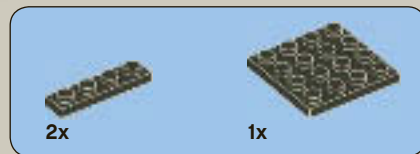
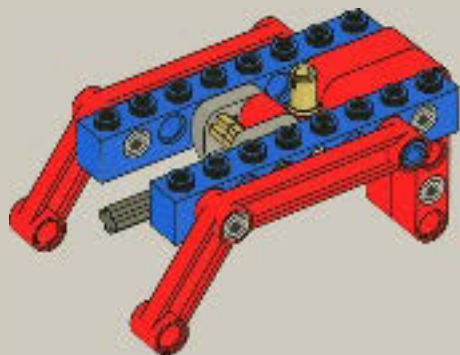

11

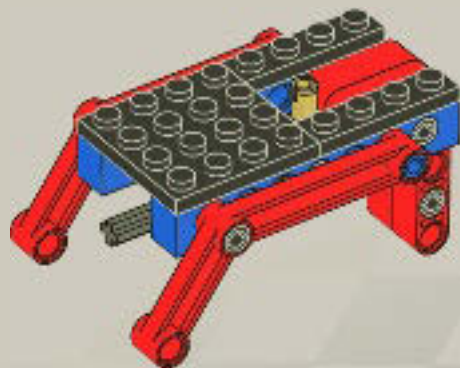

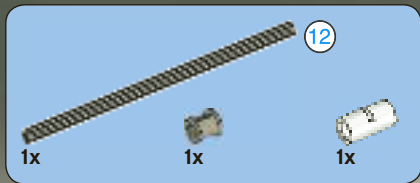

12



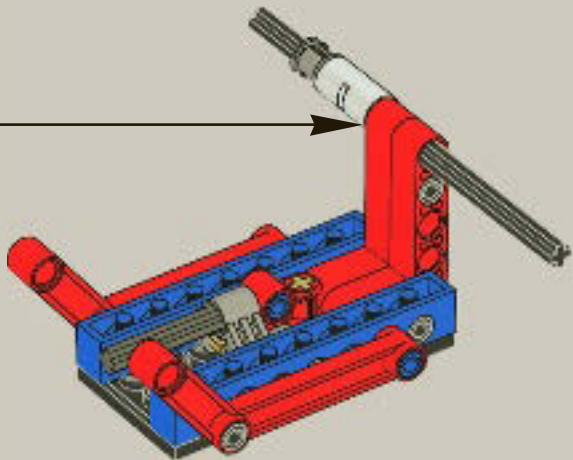

1x



1x

# 13

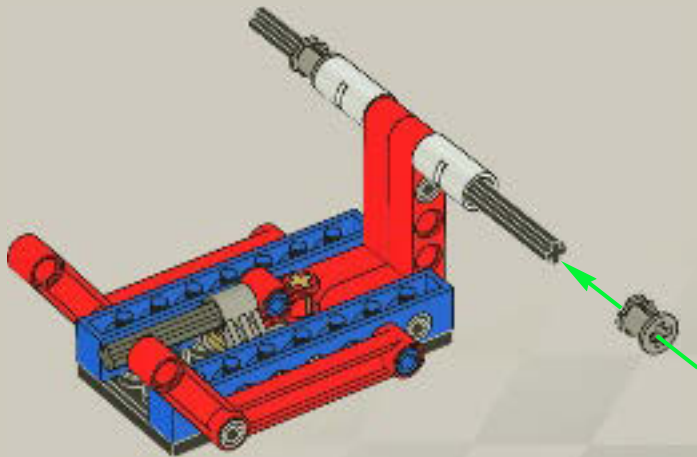



1x

# 14

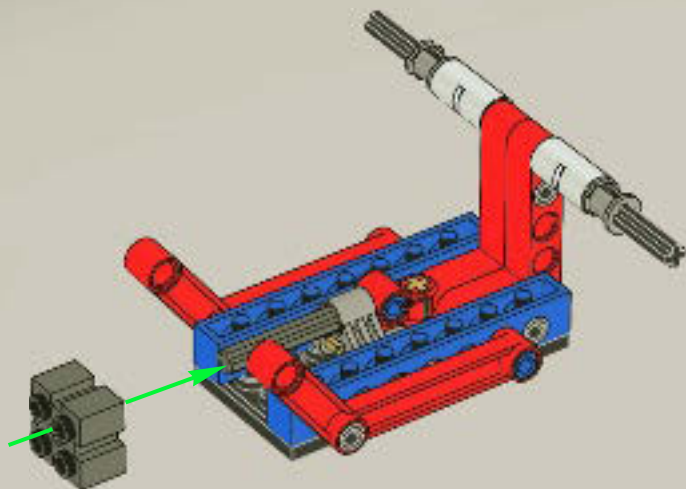

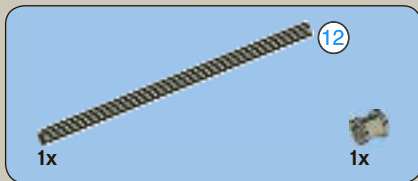

15

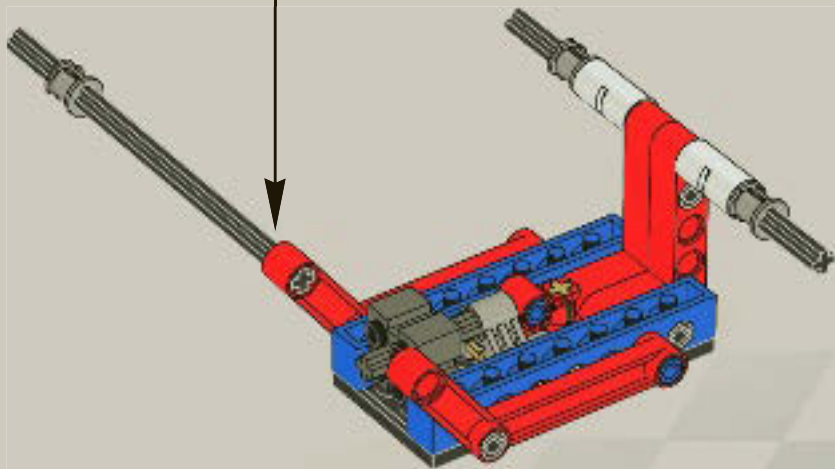



1x

# 16

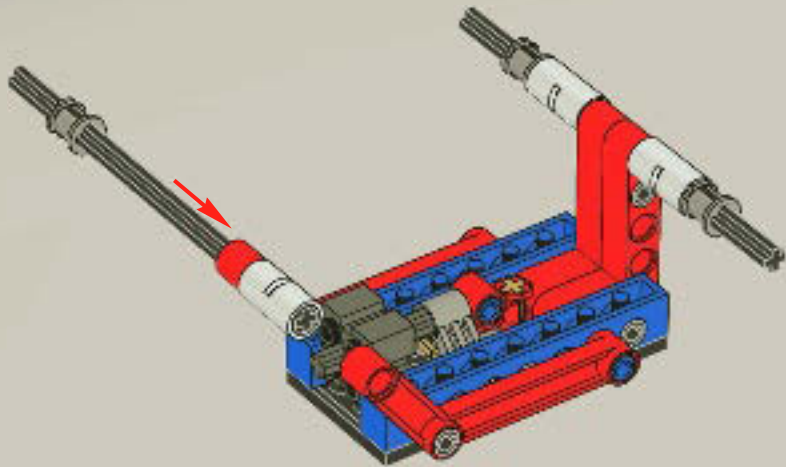





1x

# 17

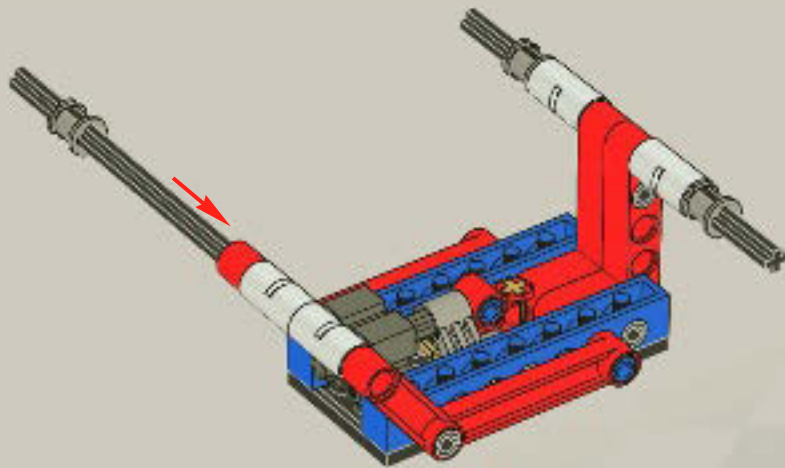



1x

# 18

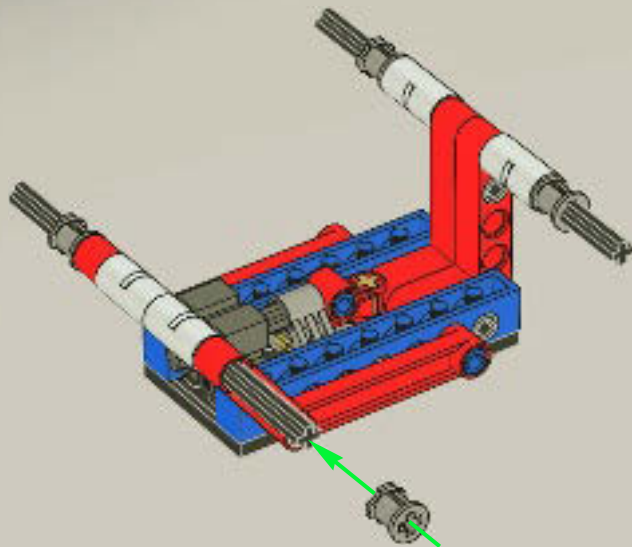

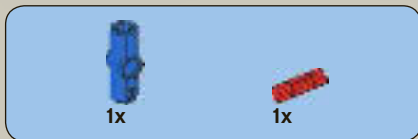

19

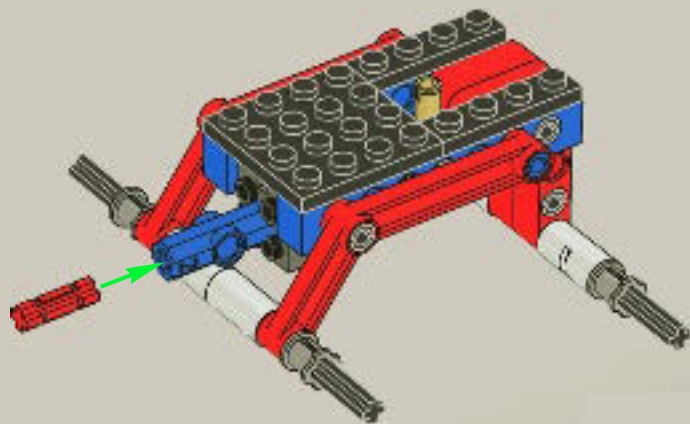
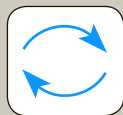



# 20

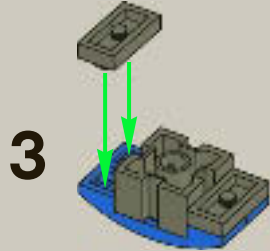



4

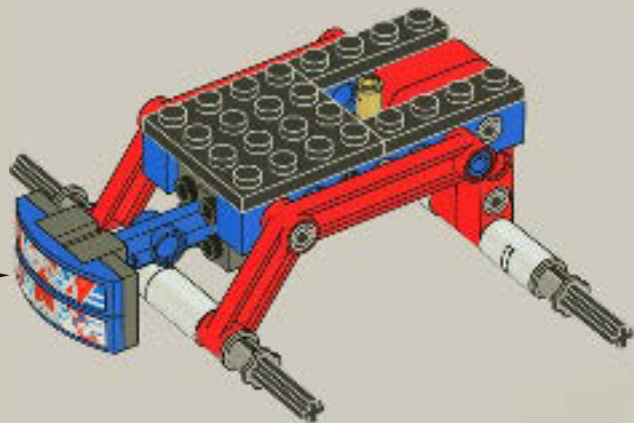



1x



2x

# 21

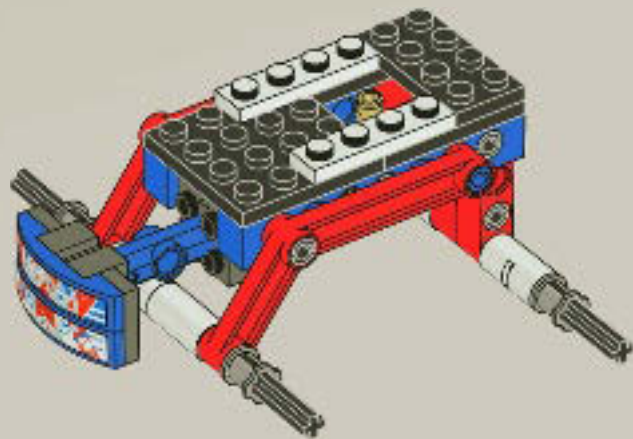

22



1x



4x

# 22

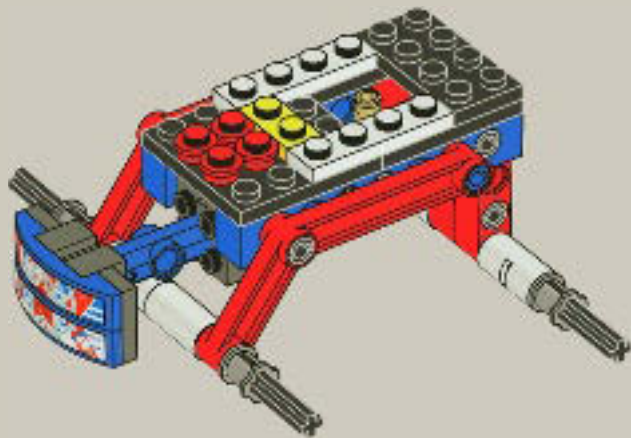

2x



1x



1x

# 23

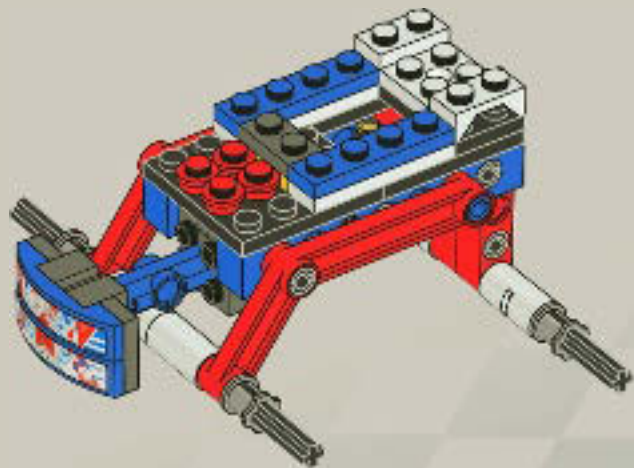



1x



1x



2x

# 24

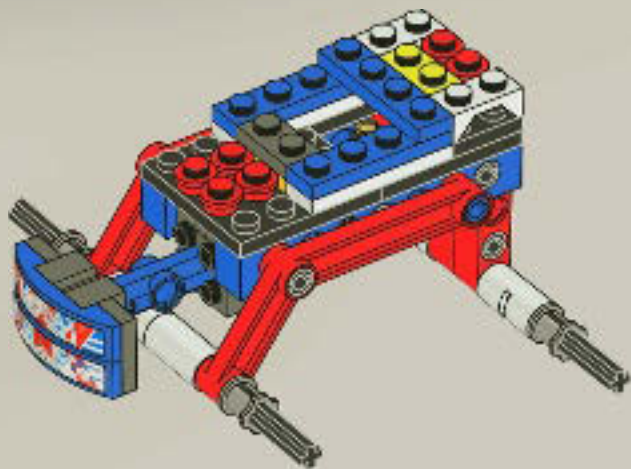

24



1x

# 25

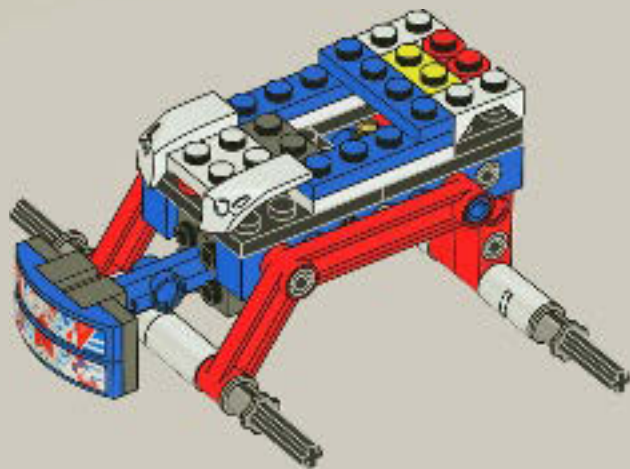





2x



1x

# 26

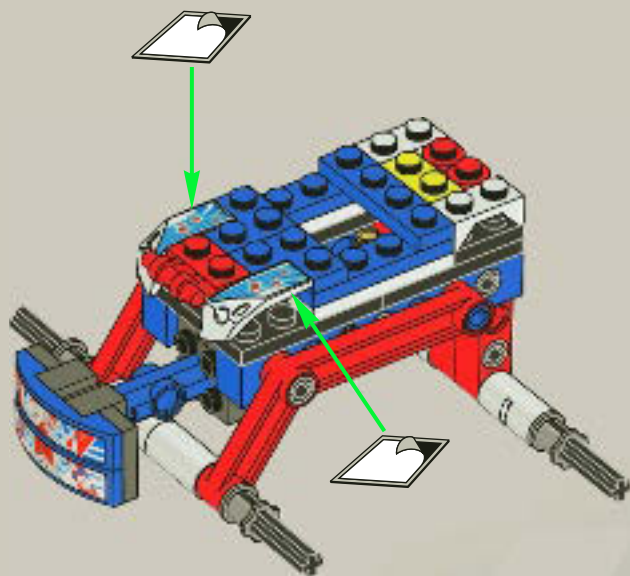



2x



2x

# 27

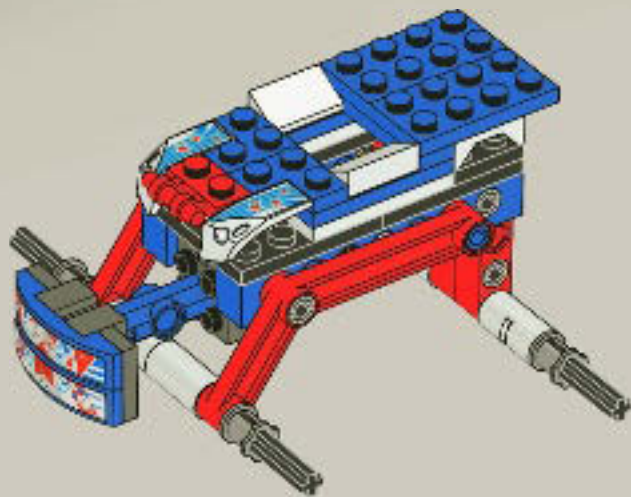



2x

# 28

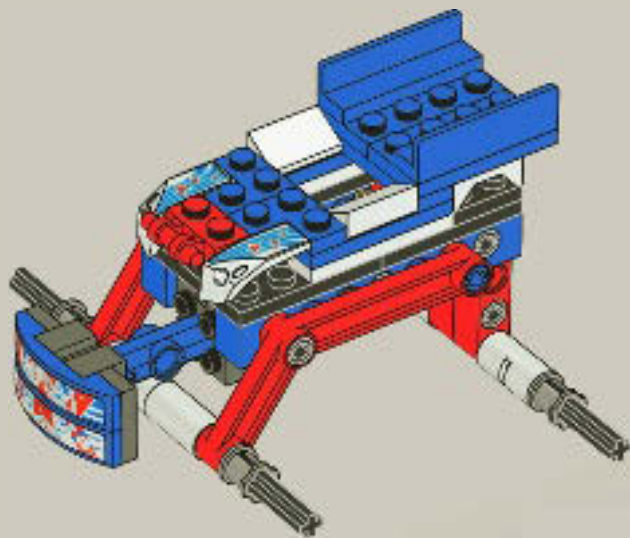



29

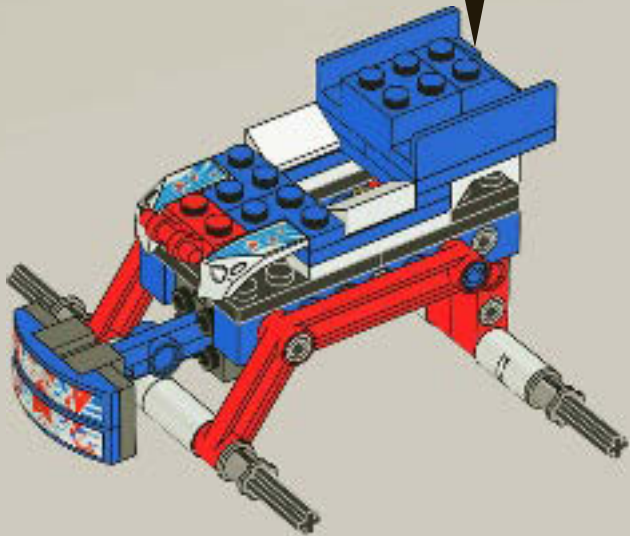



1x



1x

# 30

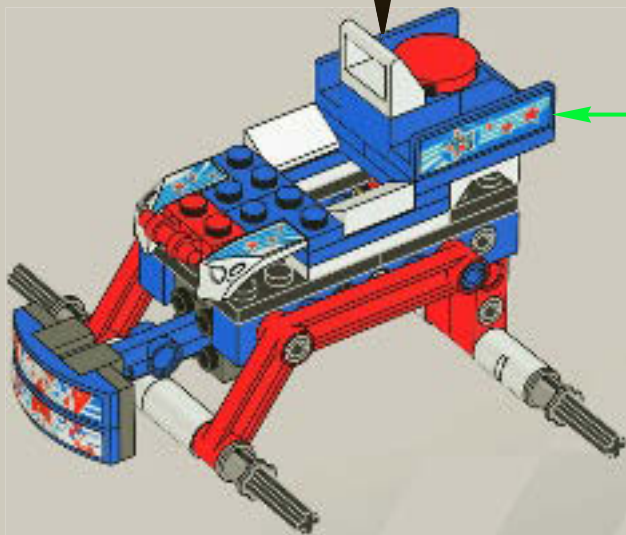



1x



1x

# 31

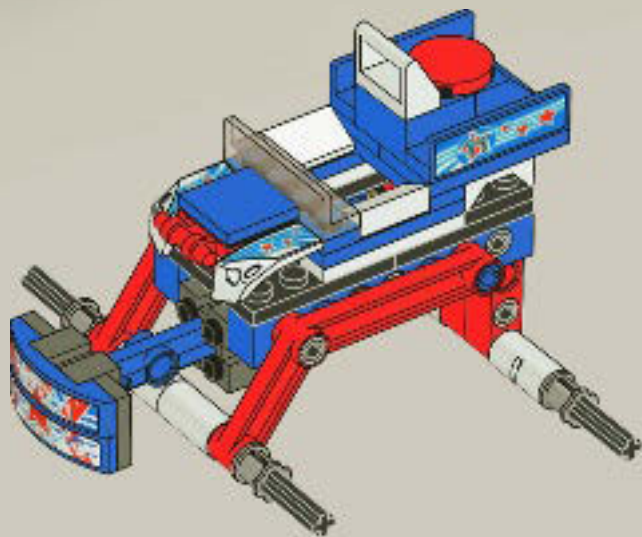



32

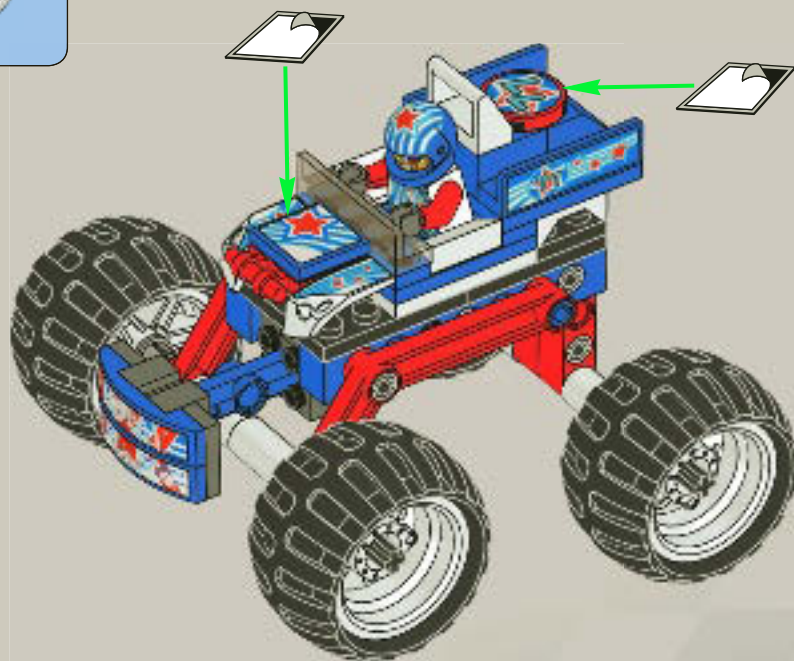

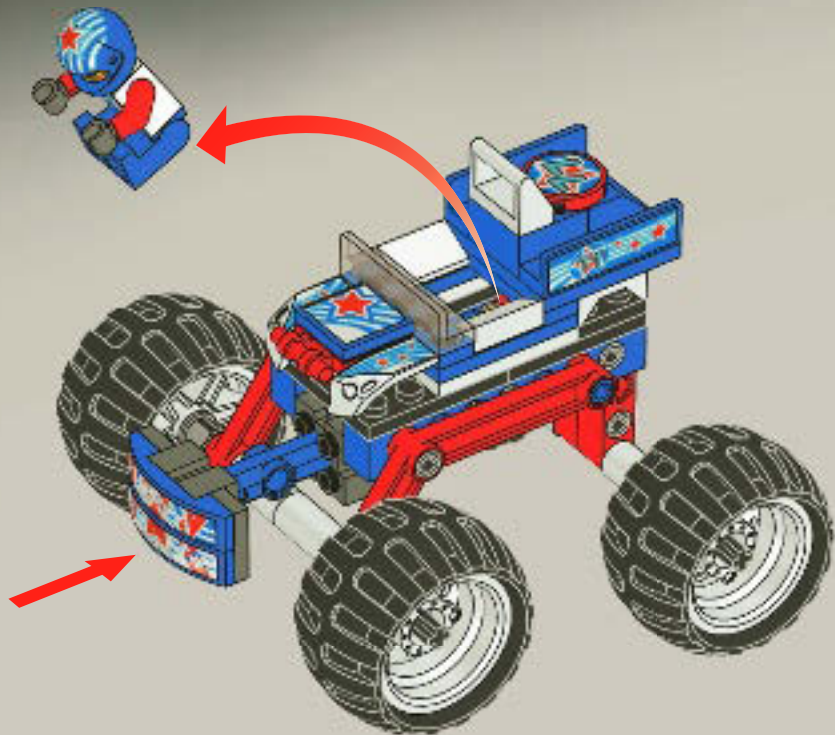



2x  
4547489

2x  
371001

1x  
4297330

1x  
4600181

1x  
243201

1x  
4651230

4x  
4624514

4x  
4526981

3x  
4186017

2x  
4539295

1x  
4140585

6x  
614121

1x  
415021

2x  
4143154

1x  
4128594

1x  
4142865

1x  
300323

2x  
370223

1x  
303923

2x  
4649773

1x  
306823

2x  
242023

3x  
371023

2x  
302023

1x  
9341

1x  
4651325

1x  
4107798

1x  
4143005

2x  
4514553

2x  
4522164

1x  
4243819

4x  
4518826

2x  
371026

1x  
302026

6x  
4121715

1x  
370526

2x  
370826

1x  
4201201

4x  
4211622

1x  
4630114

2x  
302324

1x  
4583827

2x  
4583879

3x  
4211063

1x  
4560177

4

12



Customer Service

Kundenservice

Service Consommateurs

Servicio Al Consumidor

[www.lego.com/service](http://www.lego.com/service) or dial

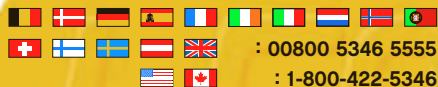

: 00800 5346 5555

: 1-800-422-5346



**LEGO**

**RACERS** 



9092



9093



9094



9095



[www.LEGOclub.com](http://www.LEGOclub.com)



LEGO® Club Email



LEGO® Club Magazine

**LEGO** club™

**FREE! GRATIS! GRATUIT!**

**SIGN UP ONLINE!**

**[www.LEGOclub.com](http://www.LEGOclub.com)**



**00800 5346 5555\***



**1-866-534-6258 • 1-877-518-5346**

US & Canada only

Outside only

- \* Freephone. Mobile charges may apply.
- \* Numéro sans frais. Des frais peuvent s'appliquer avec les téléphones cellulaires.
- \* Gebührenfrei. Kosten für Anrufe aus Mobilfunknetzen können abweichen.
- \* Gratis telefonnummer vanaf vaste lijn.
- \* Det er et gratis nummer, når du ringer fra fasttelefon.
- \* Det är gratis, när du ringer från en fast telefon.
- \* Numéro sans frais. Des frais peuvent s'appliquer avec les téléphones portables.



# WIN!

Go to [www.LEGOsurvey.com/product](http://www.LEGOsurvey.com/product) to fill out a survey for a chance to win a cool LEGO® Product.

No purchase necessary.

Open to all residents where not prohibited.



## [www.LEGOsurvey.com/product](http://www.LEGOsurvey.com/product)

### GEWINNE!

Nimm an der Umfrage auf [www.LEGOsurvey.com/product](http://www.LEGOsurvey.com/product) teil und hab die Chance ein cooles LEGO® Produkt zu gewinnen!

Die Teilnahme am Gewinnspiel führt zu keinerlei Kaufverpflichtungen. Teilnahme in allen nicht ausgeschlossenen Ländern möglich.

### WIN!

Ga naar [www.LEGOsurvey.com/product](http://www.LEGOsurvey.com/product), vul een enquêteformulier in en maak kans op een cool LEGO® product.

Geen aankoopverplichting. Iedereen mag deelnemen, uitgezonderd ingezetenden van landen waar een enquêteverbod geldt.

### GAGNE!

Visite [www.LEGOsurvey.com/product](http://www.LEGOsurvey.com/product) pour répondre à un questionnaire et avoir une chance de gagner un produit LEGO® très cool!

Aucune obligation d'achat. Ouvert à tous les résidents des pays autorisés.

### 当てよう!

[www.LEGOsurvey.com/product](http://www.LEGOsurvey.com/product) にアクセスして、アンケートにご記入ください。当選者にはレゴ®製品を差し上げます。

お買い上げの必要はありません。

禁止されていない限り、すべての皆様にご利用いただけます。

6000516



[www.LEGO.com](http://www.LEGO.com)

LEGO and the LEGO logo are trademarks of the LEGO Group. ©2012 The LEGO Group.