



9483



 **WARNING: CHOKING HAZARD.**  
Small parts. Not for children under 3 years.

1

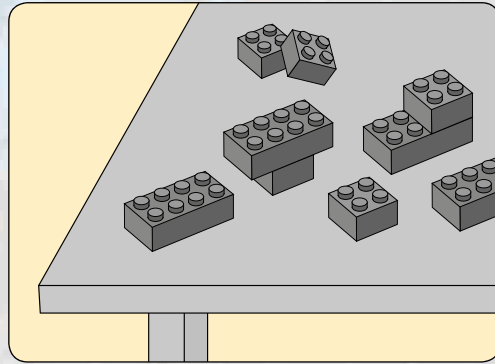
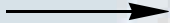
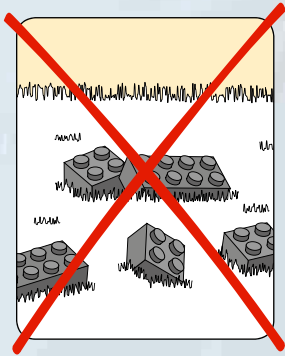

2



2

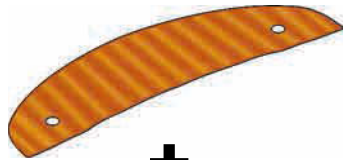

+



1



1x

1



**AVERTISSEMENT : RISQUE D'ÉTOUFFEMENT.**

Contient des petites pièces. Ne convient pas aux enfants de moins de 3 ans.



**ADVERTENCIA: PELIGRO DE ASFIXIA.**

No recomendado para niños menores de 3 años. Contiene piezas pequeñas.

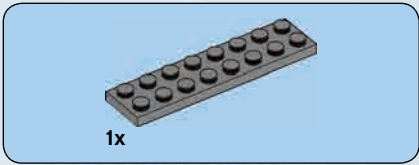

2

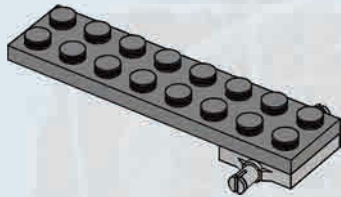

4

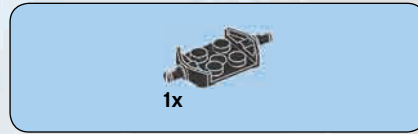

3

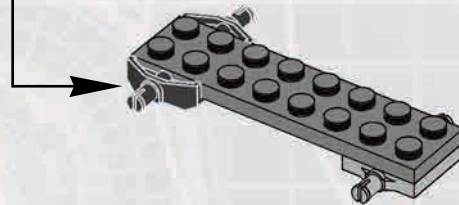
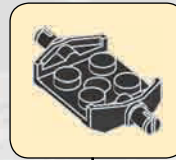



1x

4



1x

5

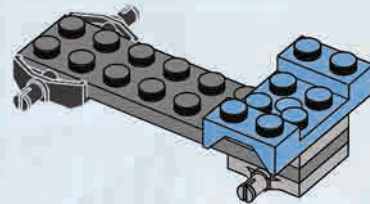



6

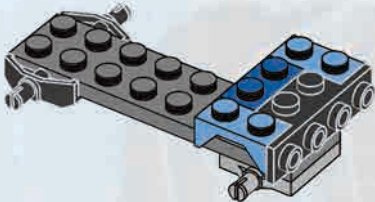

6



7

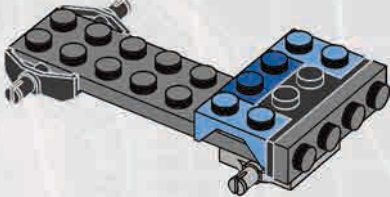
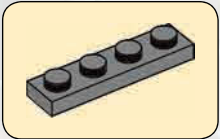



1x

8

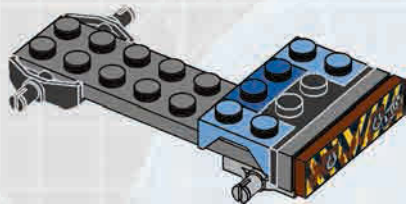

2x

9





1x

# 10



8



1x



1x

# 11

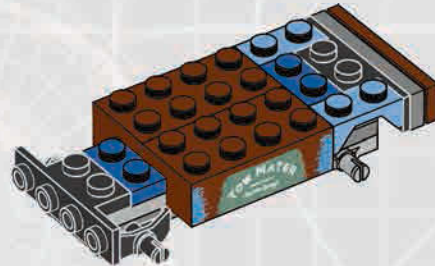





12

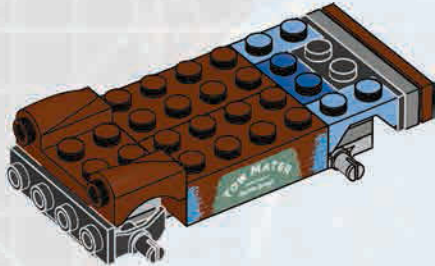

13

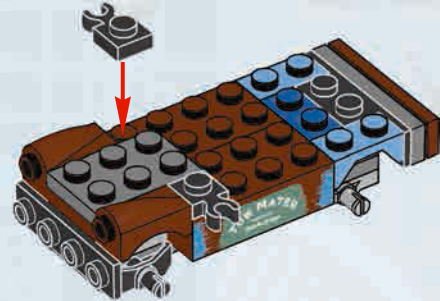

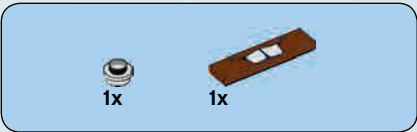

14

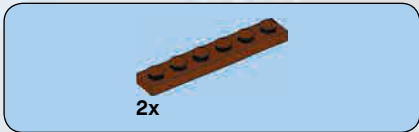
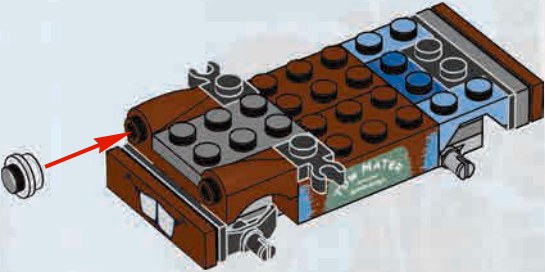

15

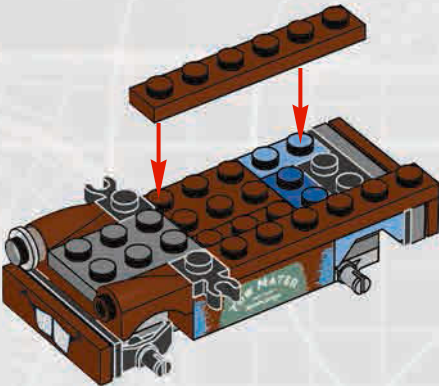



1x

16

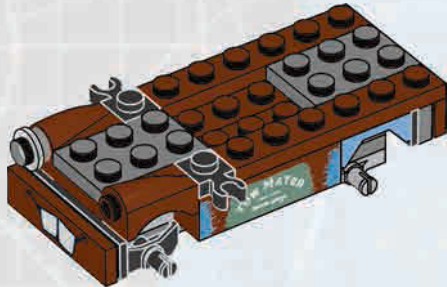

4x

17

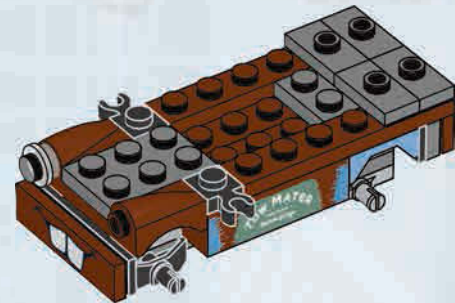



**1**

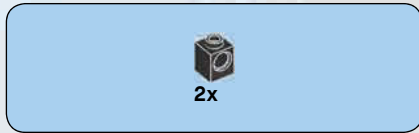

**2**

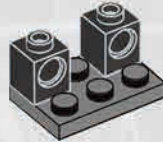



3

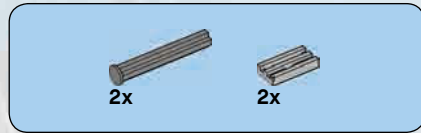
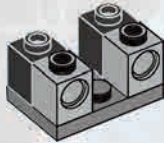

4

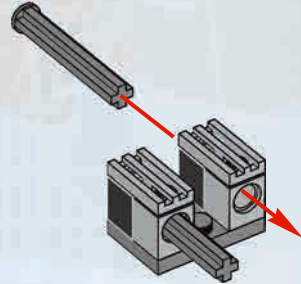



5

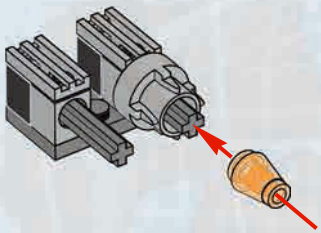

6

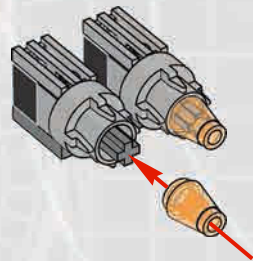



7

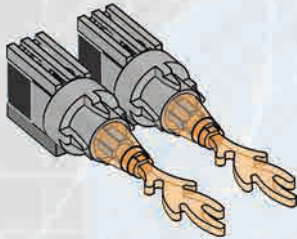

18

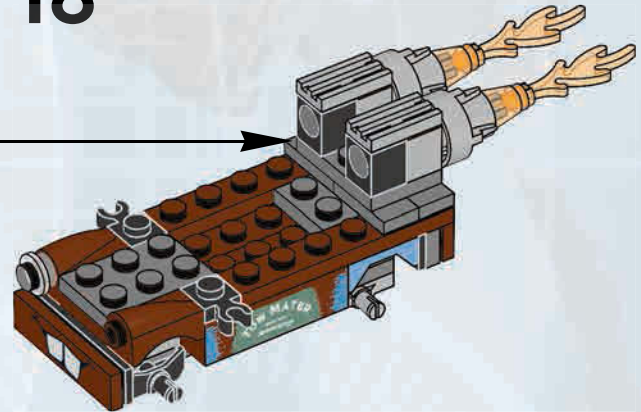



2x

19

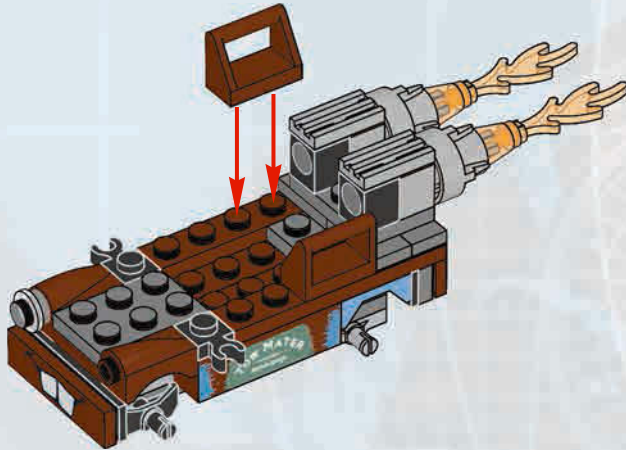

16



1x

20

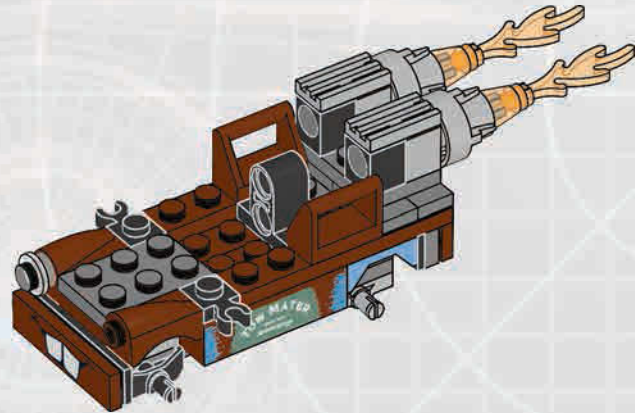





21

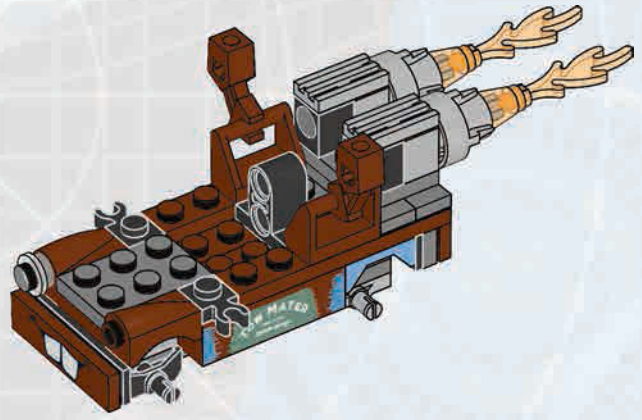

22

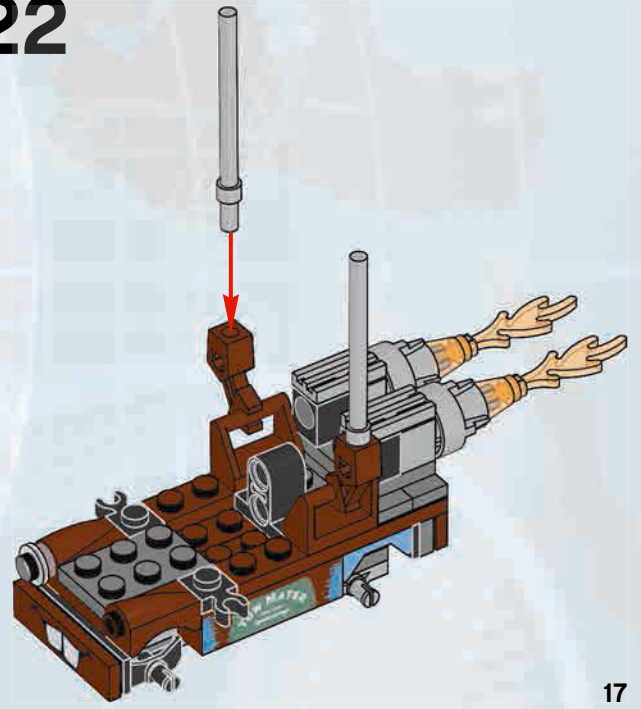

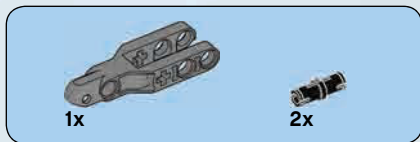

1

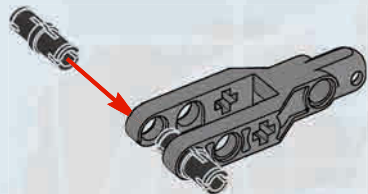

18



2

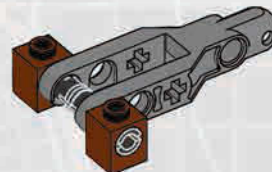

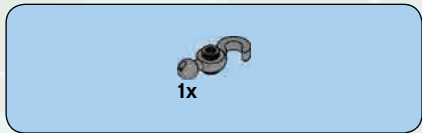

3

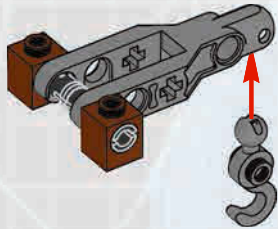

23

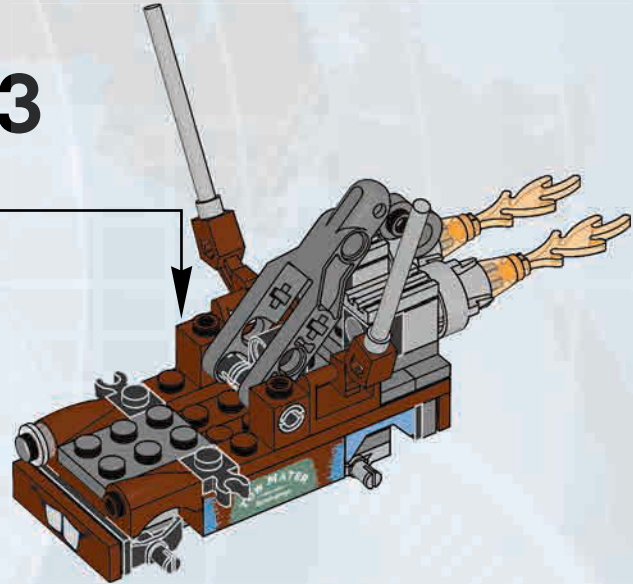

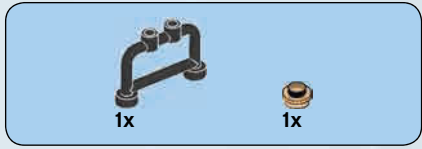

# 24

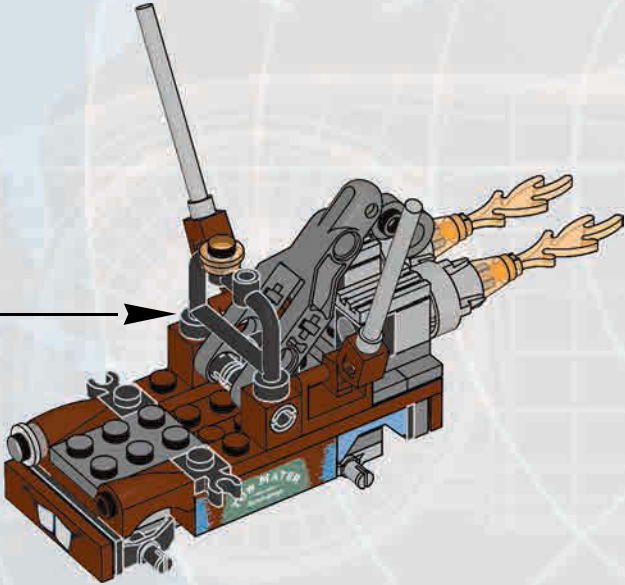
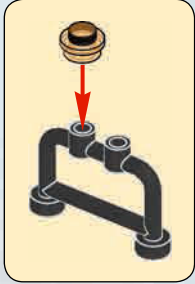

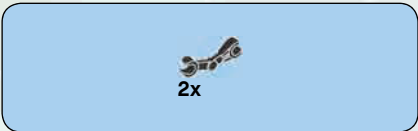

25

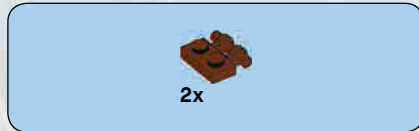
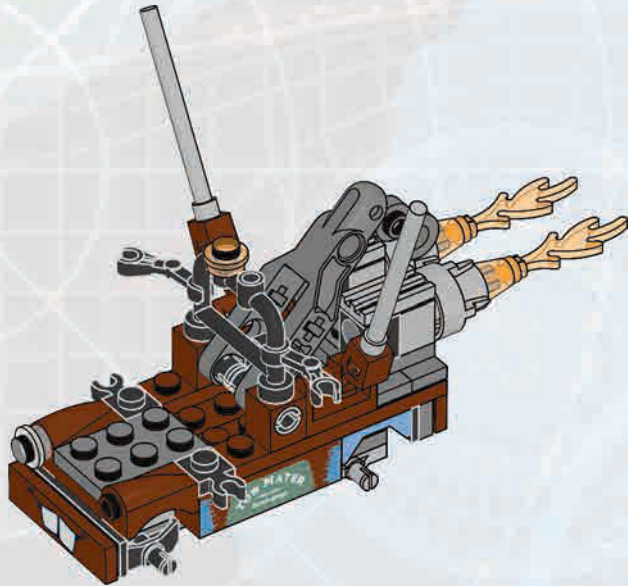

26

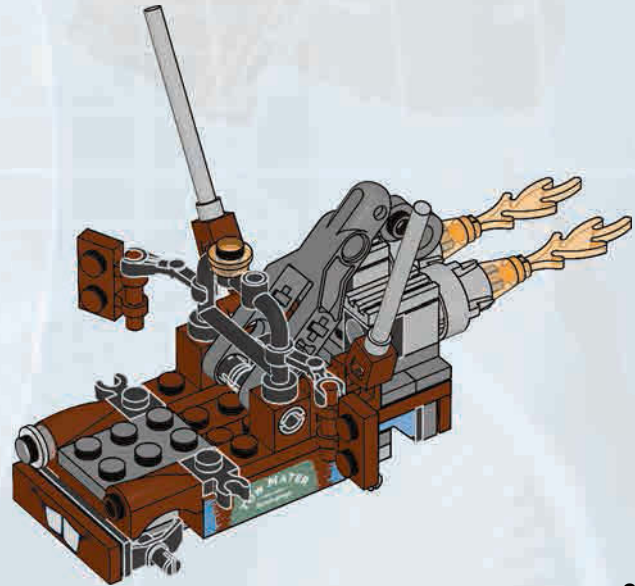

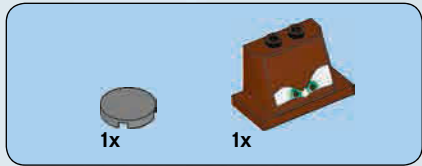

27

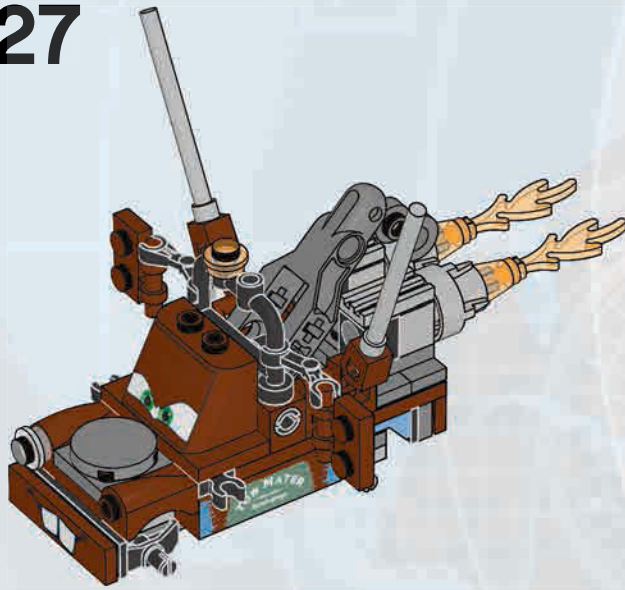

22



28

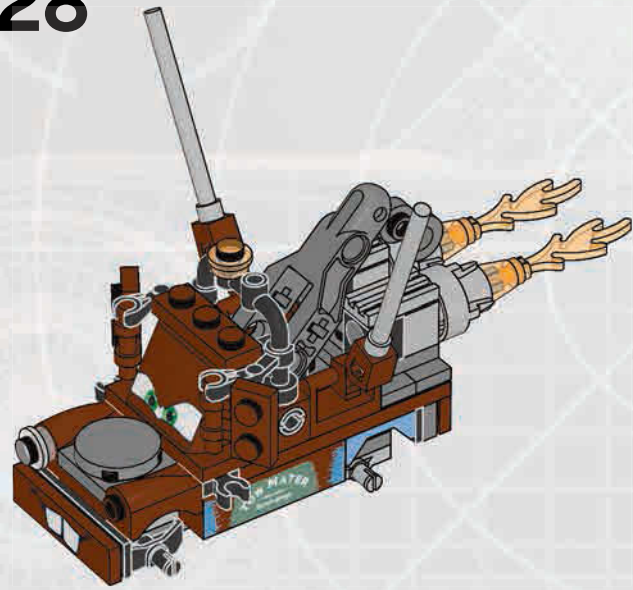



2x

29

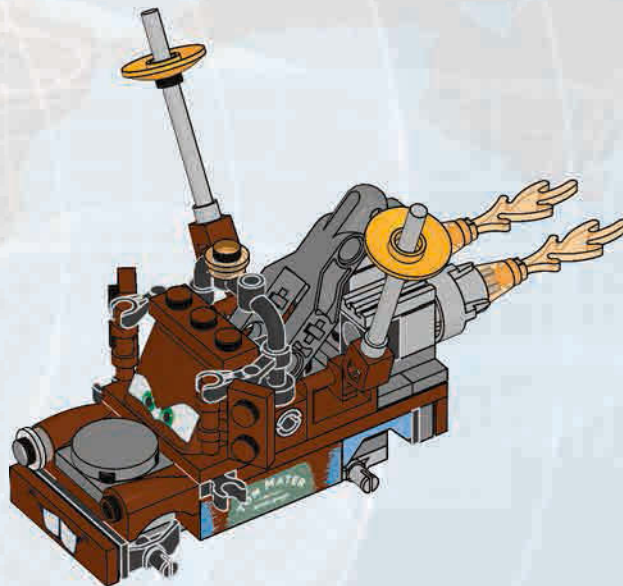

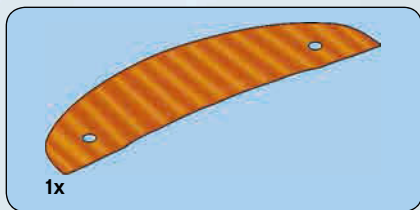

30

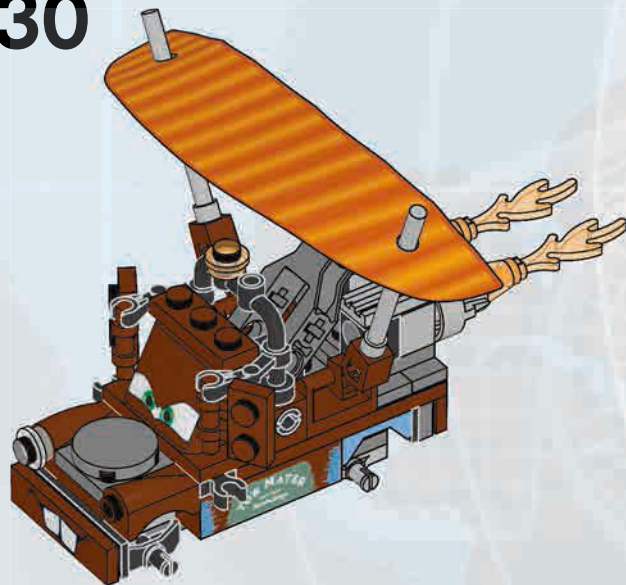

24

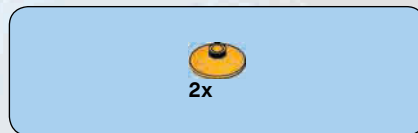

31

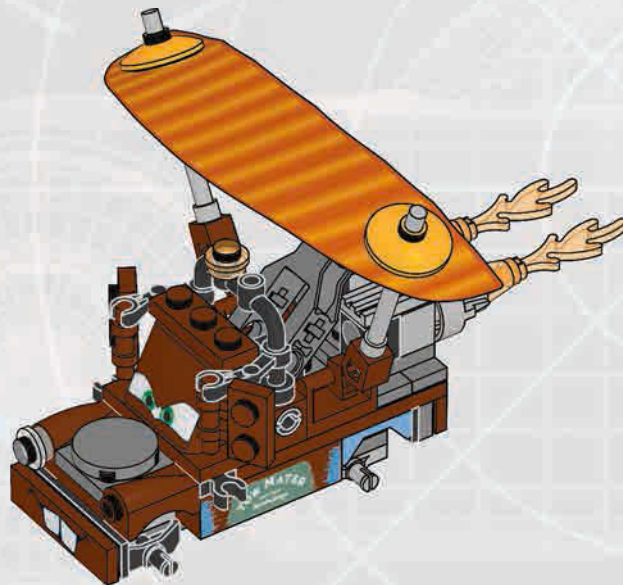





2x



2x

# 32



2x

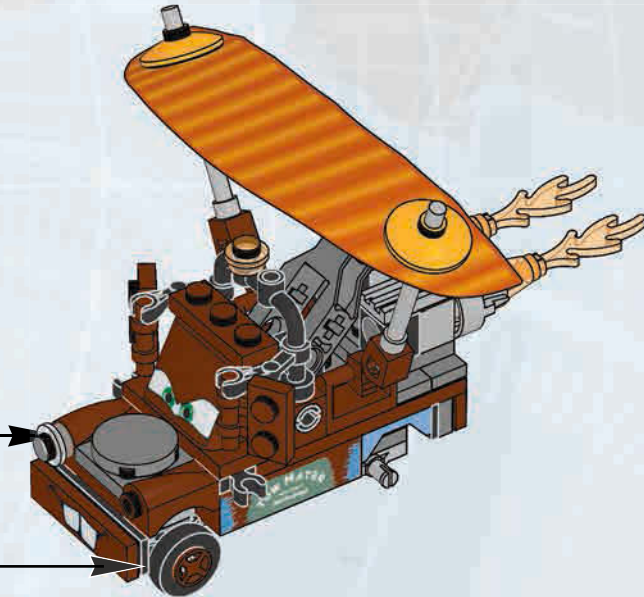

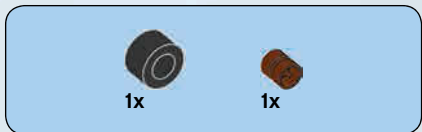

33

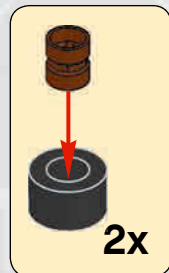
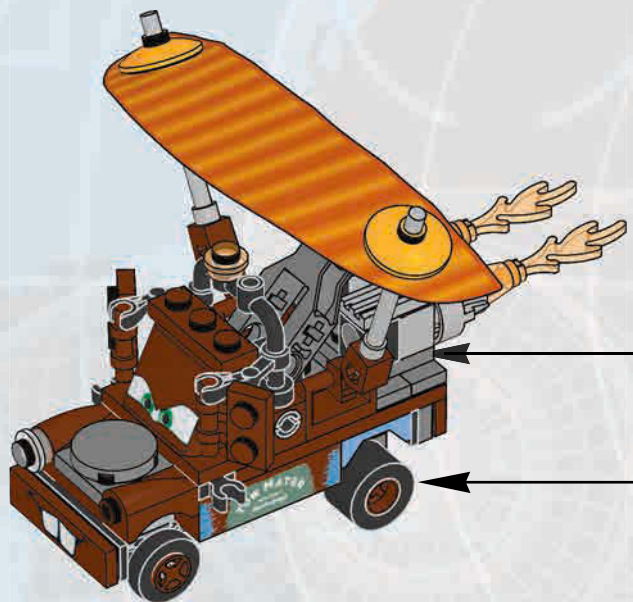



2x

# 34

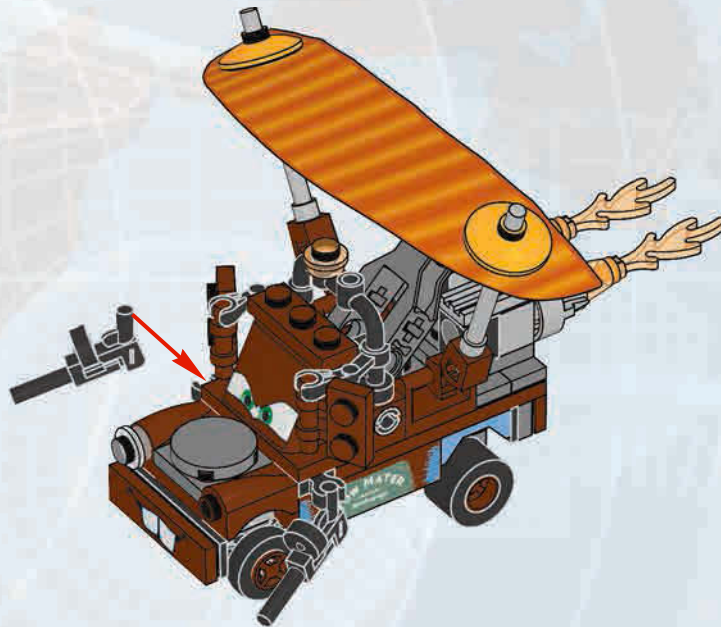

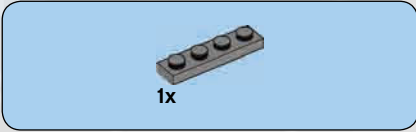
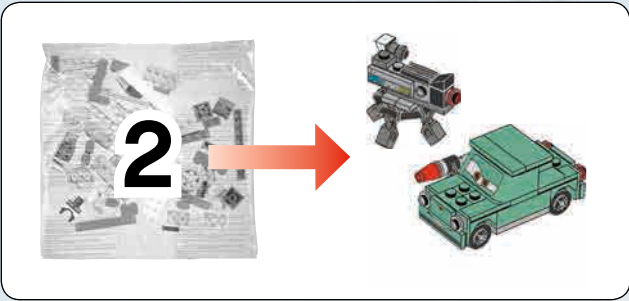

1





1x

**2**



1x

**3**

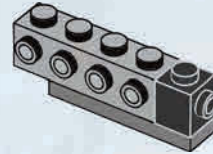

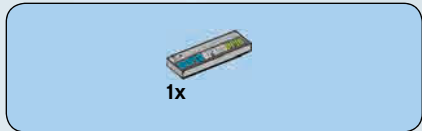

4

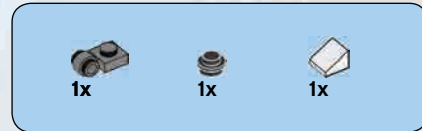

5

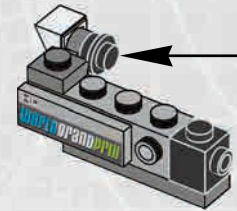



1x



1x

6

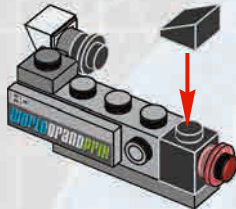

1x

7

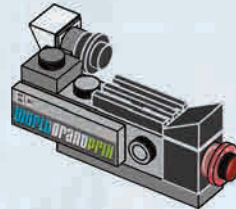

2x 1x 4x

# 8

1



2



3

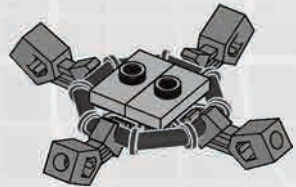



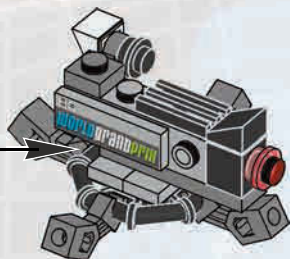

9

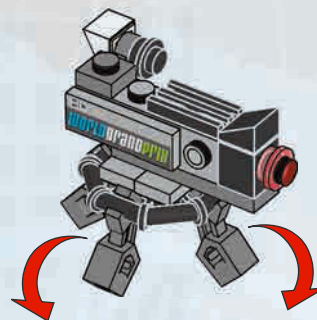

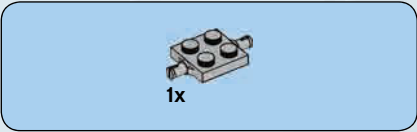

**1**

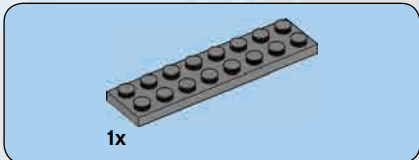

**2**



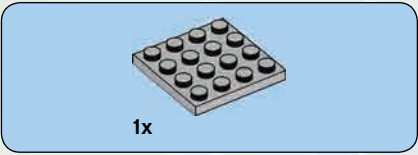

**3**

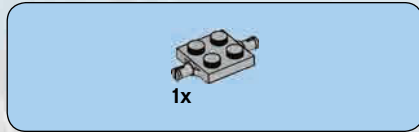
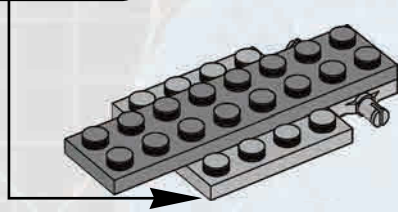
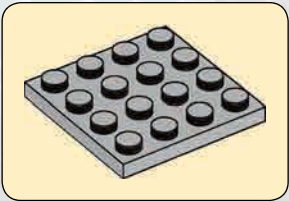

**4**

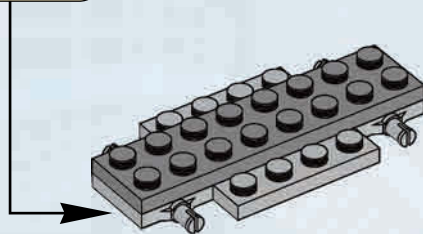
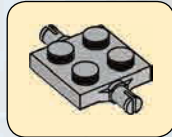

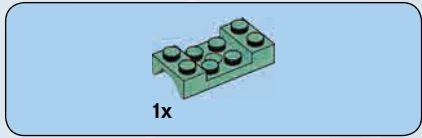

5

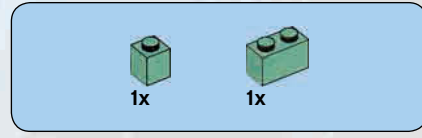
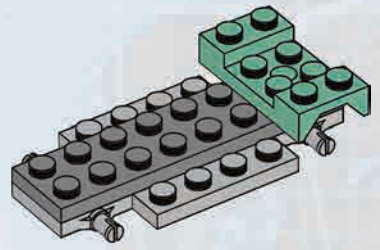

6

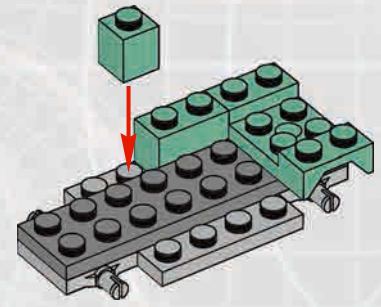



1x



1x

7

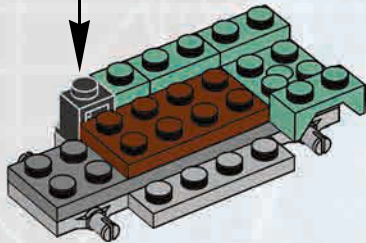

1x

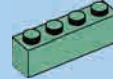

1x

8

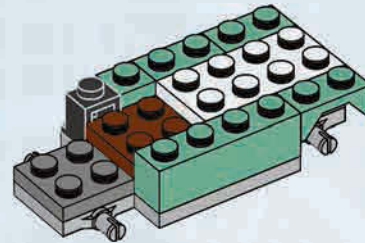

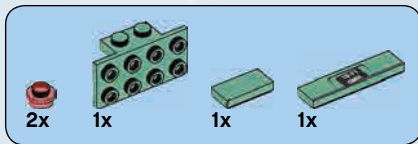

9

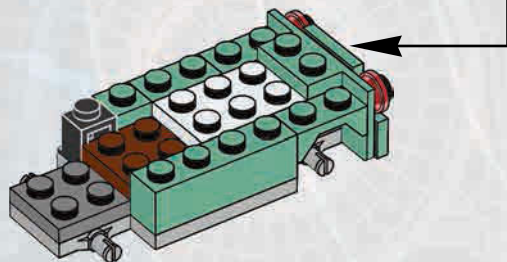
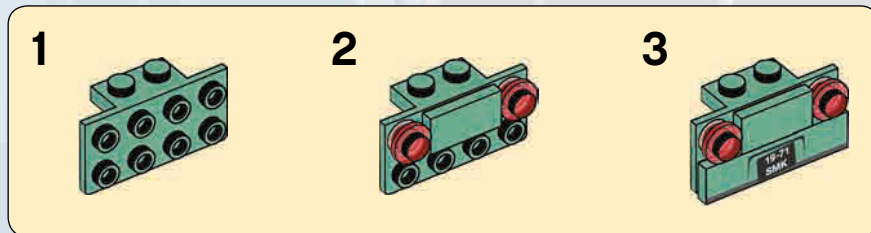

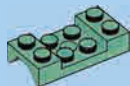

1x

10

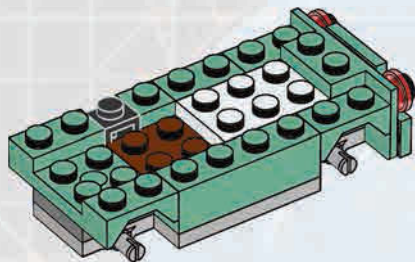

1x

11

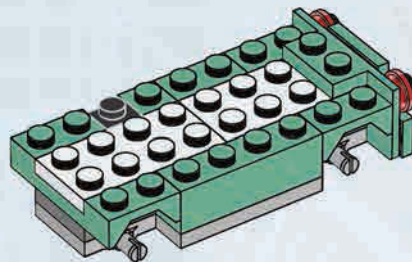

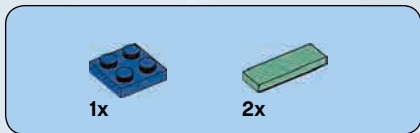

12

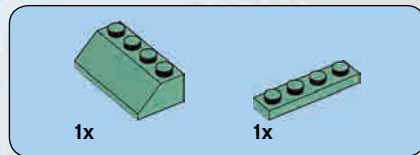
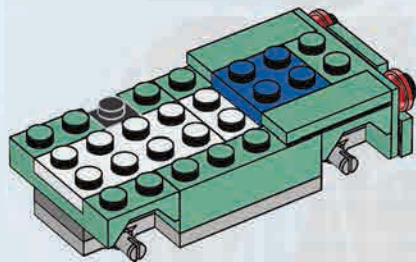

13

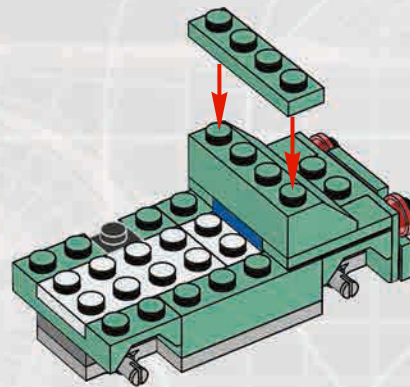





1x

# 14

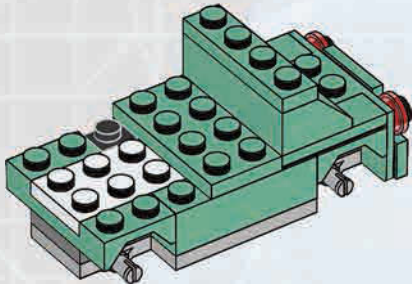

2x



2x

# 15

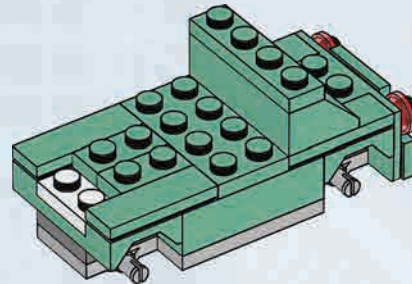

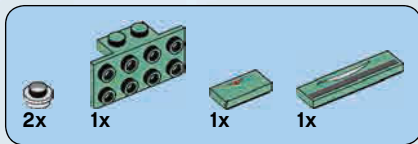

# 16

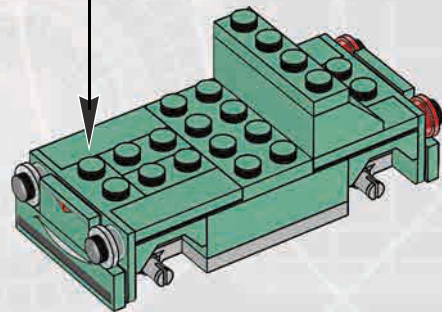
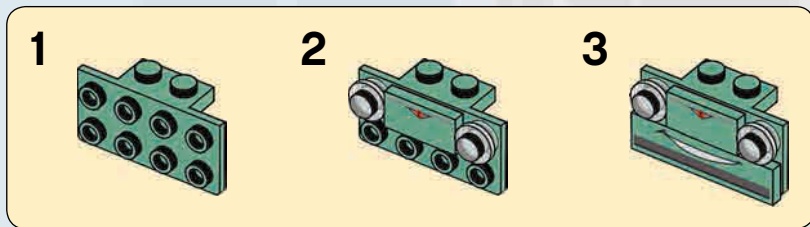

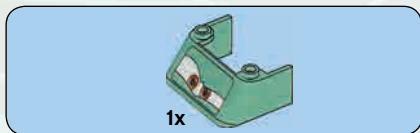

17

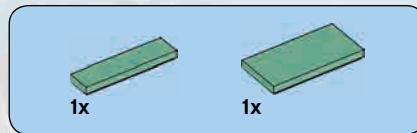
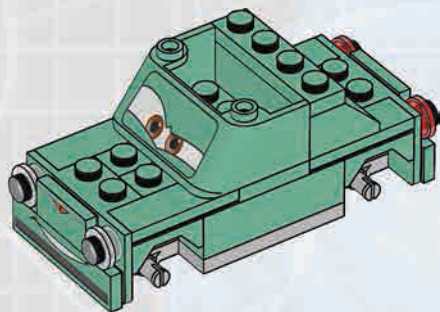

18

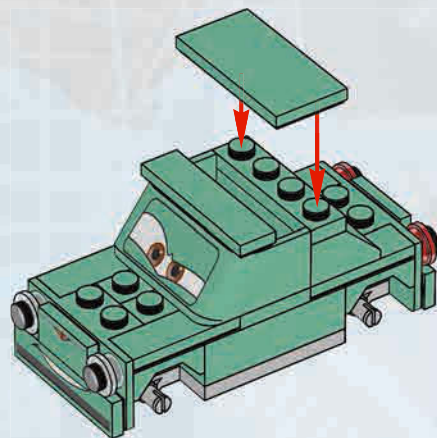



19

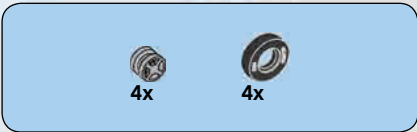
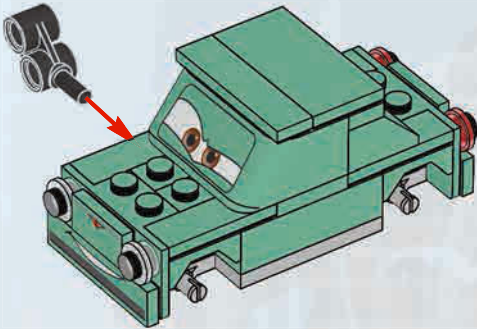

20

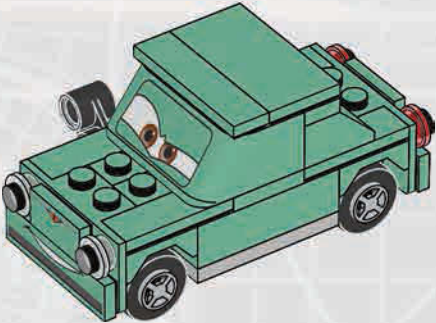

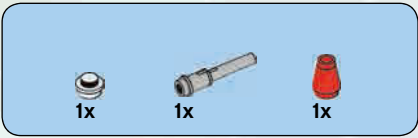

21

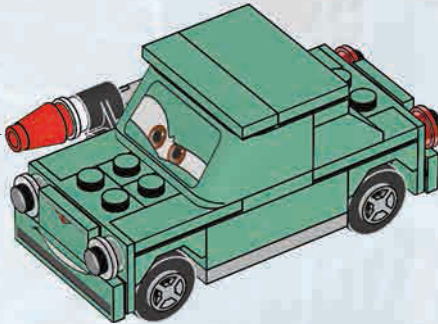

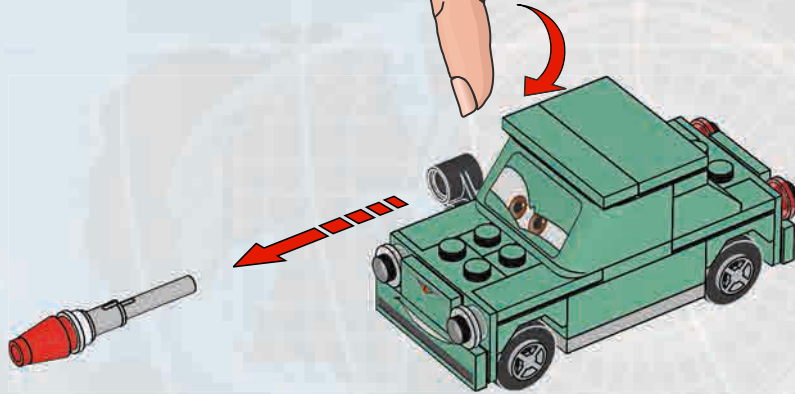



1x  
4504369



2x  
654126



2x  
4223247



1x  
4654964



1x  
4633698



1x  
4633072



2x  
302001



1x  
4504382



2x  
4549989



1x  
4558954



1x  
4521948



1x  
4616710



1x  
4654926



1x  
614101



2x  
4550017



2x  
4508215



1x  
4514342



1x  
4616581



1x  
4616578



1x  
4616588



1x  
4529234



1x  
241226



6x  
4516843



1x  
408326



1x  
4521947



2x  
4616576



2x  
4625234



2x  
302323



1x  
4144024



1x  
615726



3x  
3005740



2x  
4655080



1x  
4654923



1x  
4633693



1x  
302223



2x  
4282746



1x  
4562148



1x  
4616698



1x  
4654927



4x  
4655077



1x  
4654928



## Customer Service

Kundenservice

Service Consommateurs

Servicio Al Consumidor

[www.lego.com/service](http://www.lego.com/service) or dial



00800 5346 5555 :

1-800-422-5346 :



2011



8639



8423, 8639, 8679



8426



8487



8200, 8487



8487



8206, 8484, 8679



8206, 8679



8487



8424



8639



8423, 8679



8638



8638



8487



8638



8638



8638

2011



8201, 8487



8639



8639



8486



8426, 8639



8639



8426



8638



8486



8679



8679



8679



8679



8424

2012



9486



9485



9486



9481



9480



9483



9484



9485



9479



9484



9486



9483



9486



9485



9486



9485



9478





# WIN!

Go to [www.LEGOsurvey.com/product](http://www.LEGOsurvey.com/product)  
to fill out a survey for a chance  
to win a cool LEGO® Product.

No purchase necessary.

Open to all residents where not prohibited.



## [www.LEGOsurvey.com/product](http://www.LEGOsurvey.com/product)

### GEWINNE!

Nimm an der Umfrage auf [www.LEGOsurvey.com/product](http://www.LEGOsurvey.com/product) teil und hab die Chance ein cooles LEGO® Produkt zu gewinnen!  
Die Teilnahme am Gewinnspiel führt zu keinerlei Kaufverpflichtungen. Teilnahme in allen nicht ausgeschlossenen Ländern möglich.

### WIN!

Ga naar [www.LEGOsurvey.com/product](http://www.LEGOsurvey.com/product), vul een enquêteformulier in en maak kans op een cool LEGO® product.  
Geen aankoopverplichting. Iedereen mag deelnemen, uitgezonderd ingezetenden van landen waar een enquêteverbod geldt.

### GAGNE!

Visite [www.LEGOsurvey.com/product](http://www.LEGOsurvey.com/product) pour répondre à un questionnaire et avoir une chance de gagner un produit LEGO® très cool!  
Aucune obligation d'achat.  
Ouvert à tous les résidents des pays autorisés.

### 当てよう!

[www.LEGOsurvey.com/product](http://www.LEGOsurvey.com/product) にアクセスして、アンケートにご記入ください。  
当選者にはレゴ®製品を差し上げます。  
お買い上げの必要はありません。  
禁止されていない限り、すべての皆様にご利用いただけます。

 [www.LEGO.com](http://www.LEGO.com)

6003660

LEGO and the LEGO logo are trademarks of the/sont des marques de commerce de/son marcas registradas de LEGO Group. ©2012 The LEGO Group. © Disney/Pixar