



Friends



3063



Andrea



Olivia



Mia



Stephanie



Friends



Emma

1

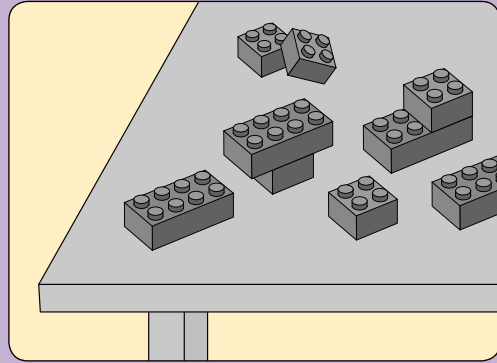
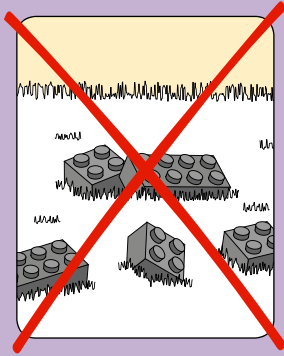

2



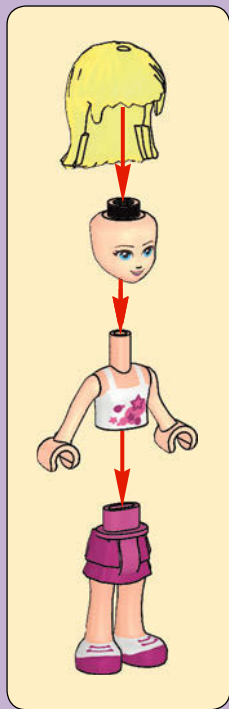
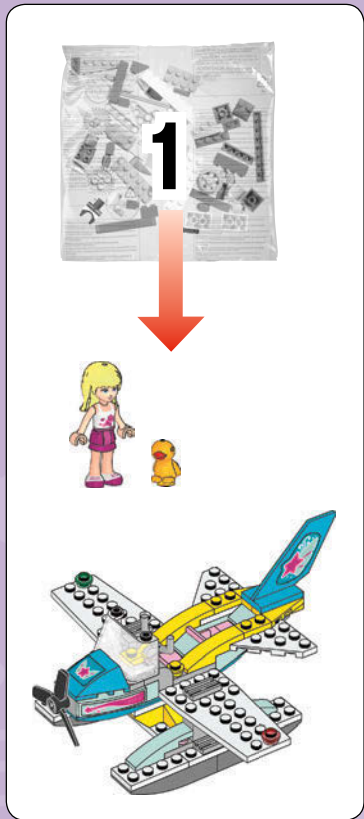

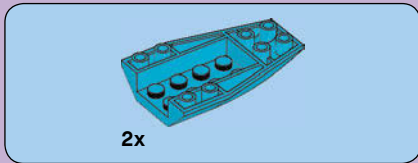

2x

1

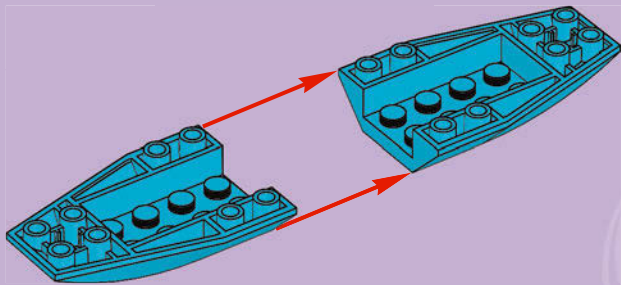

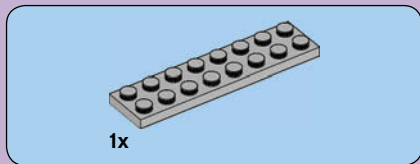

2

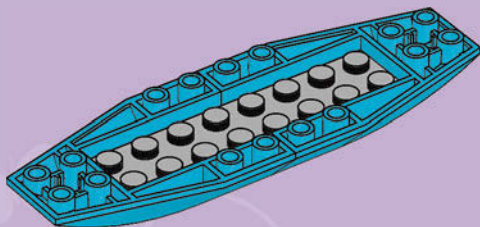

3

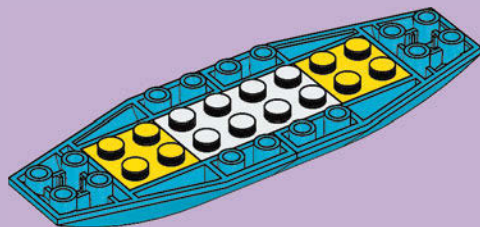



1x



4x

4



4x

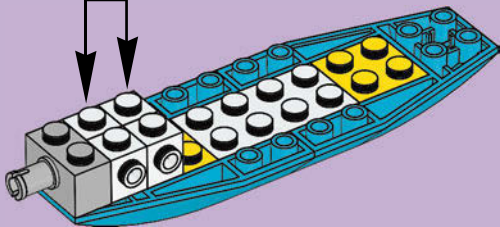

1x



2x

5

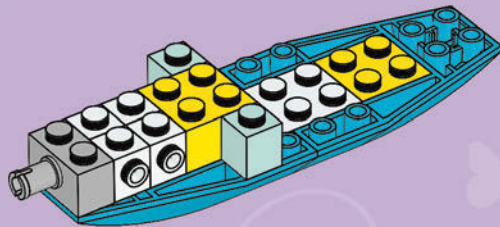



6

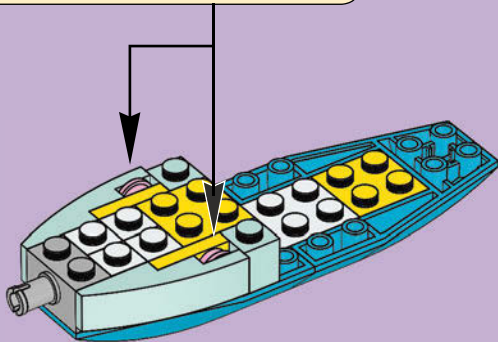

7

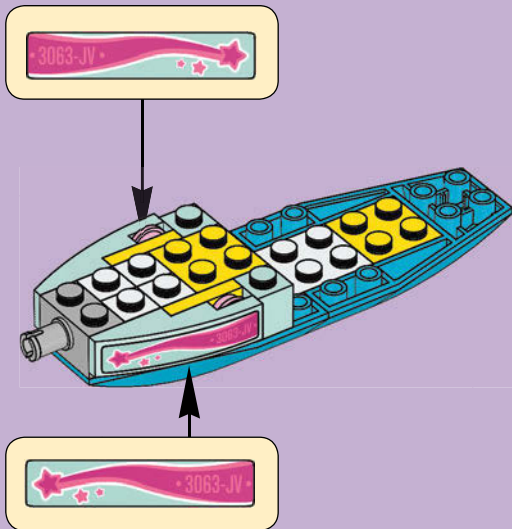

8

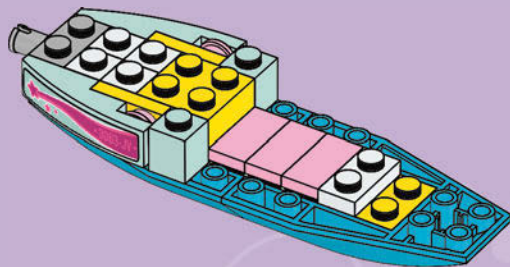

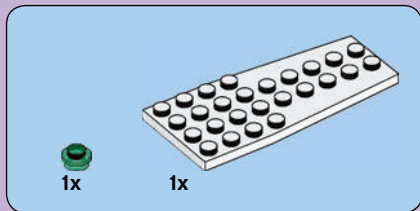

9

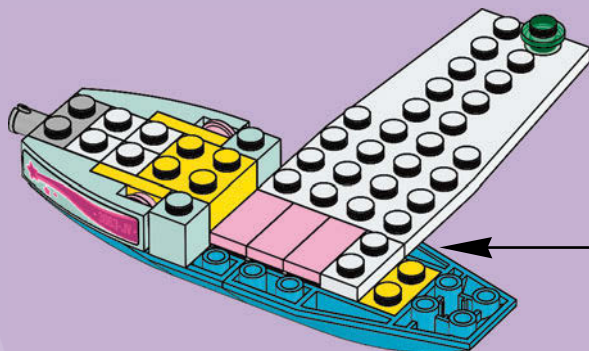
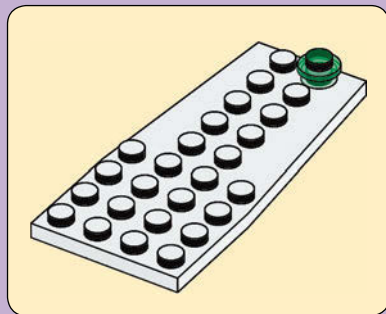

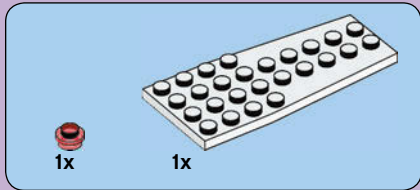

10

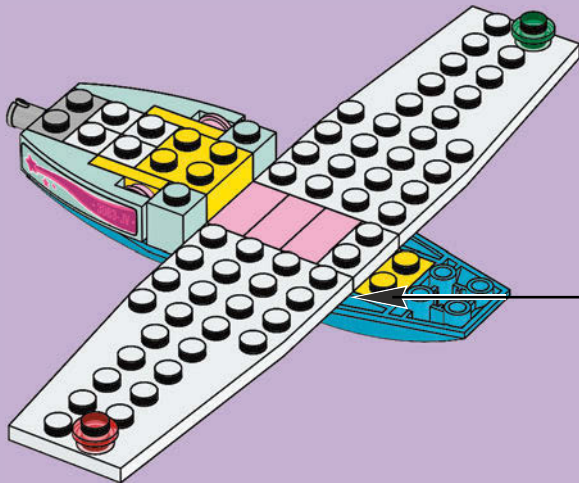
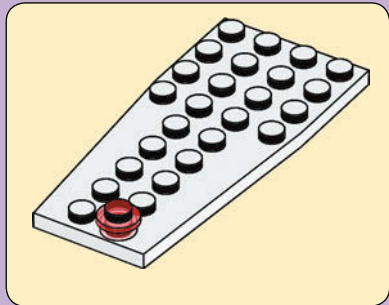



1x



2x



2x

11

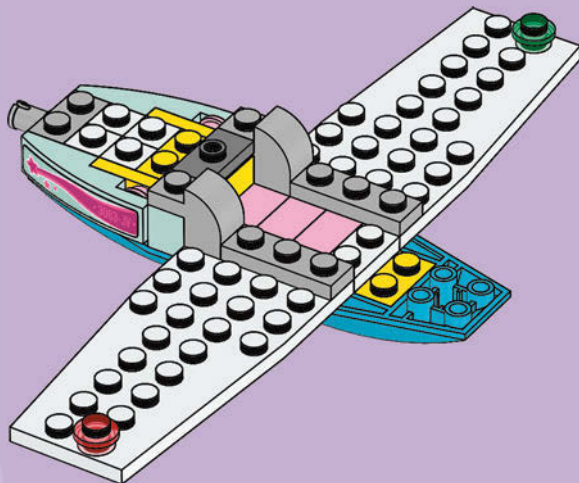



2x



1x

12

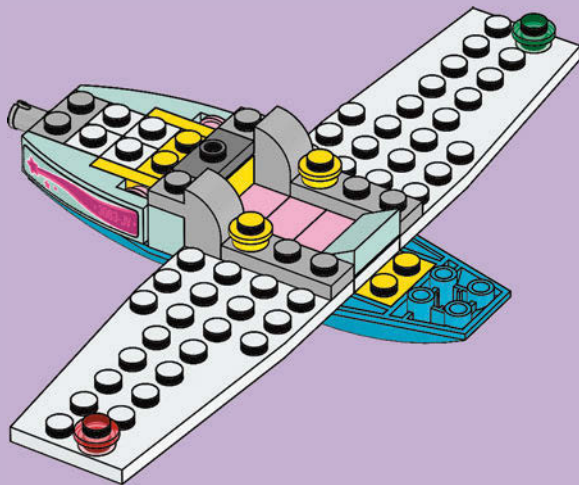



1x



1x

3

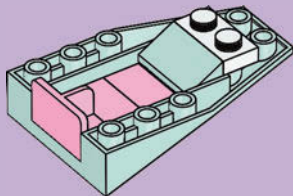

2x

4

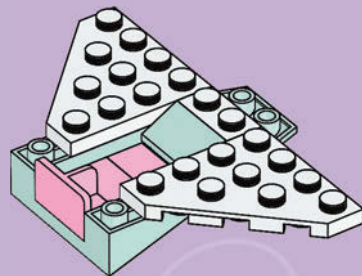



5

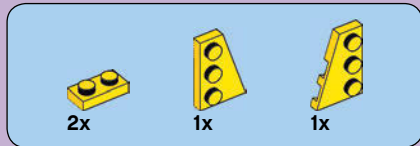
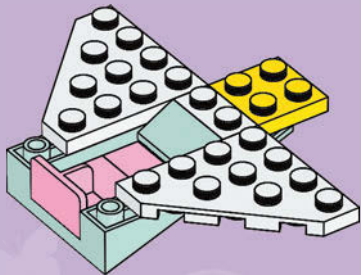

6

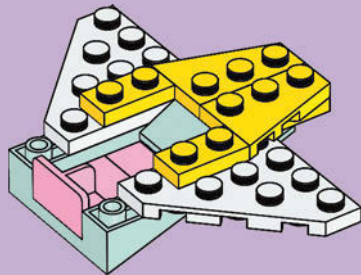

13

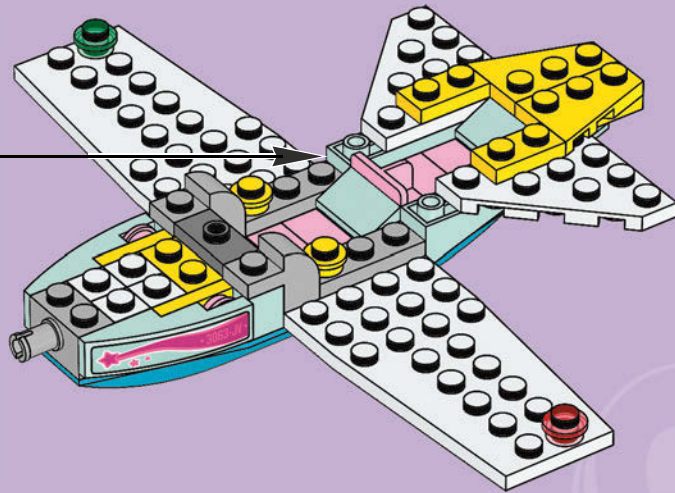



2x

14

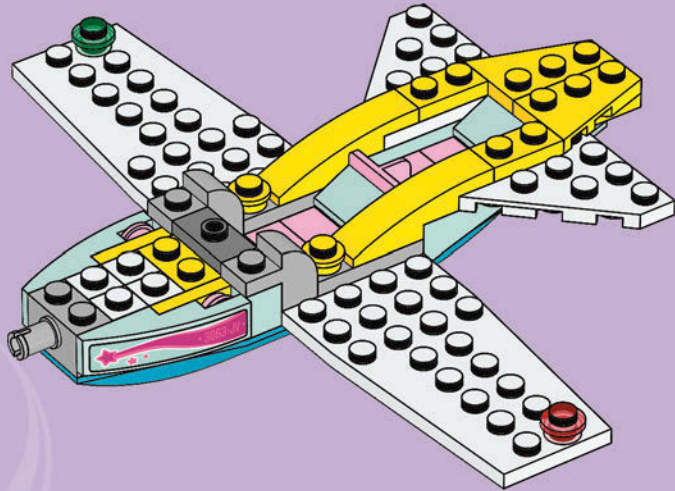



15

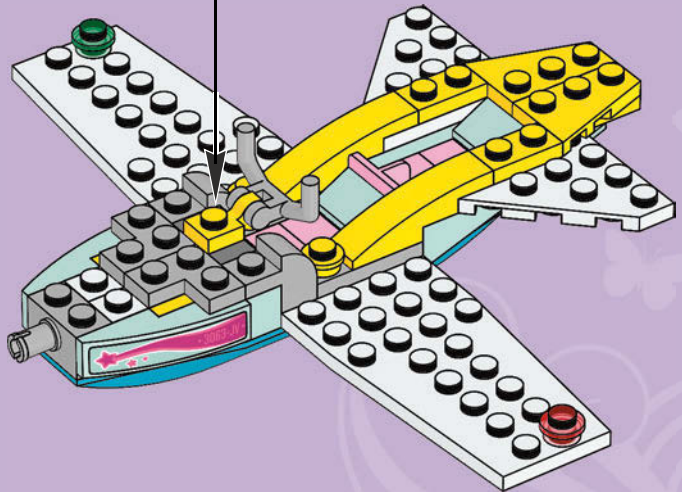
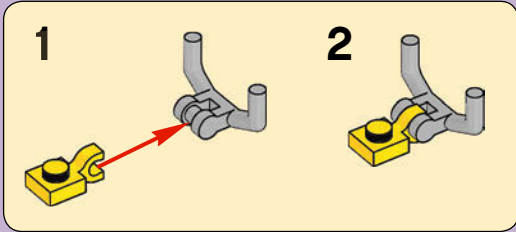

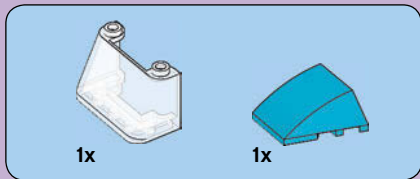

16

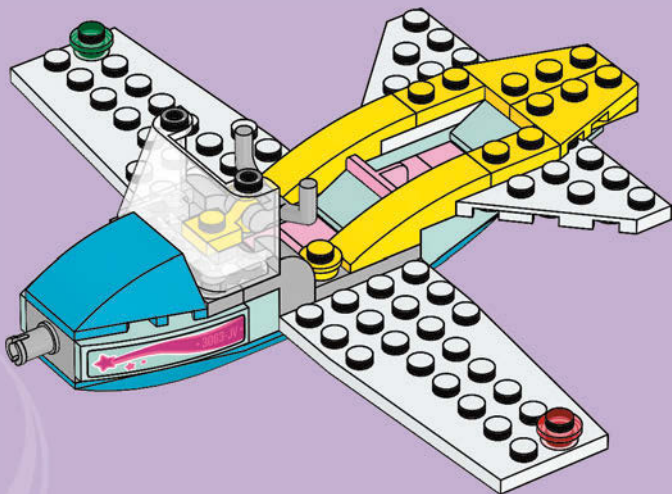

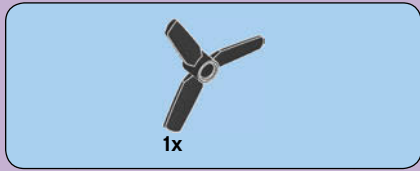

17

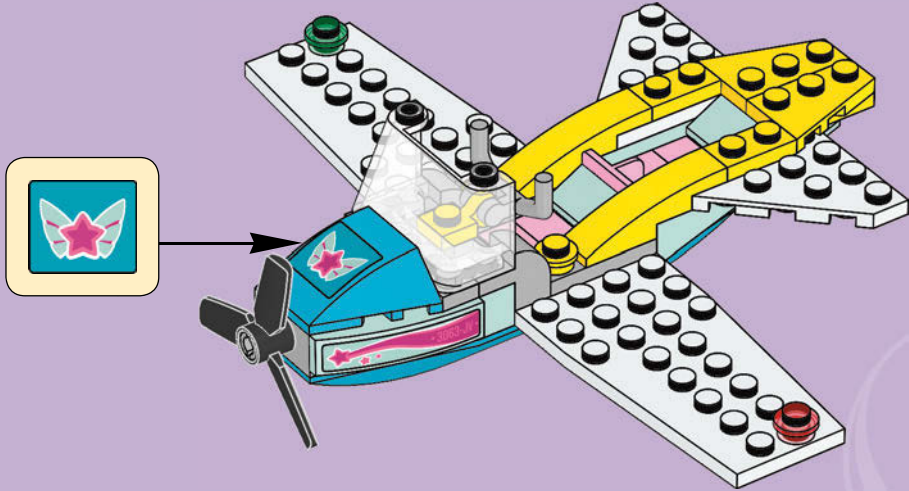

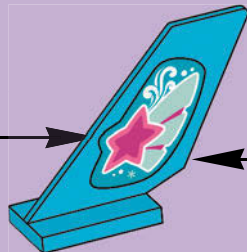
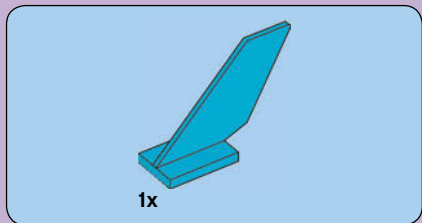

18

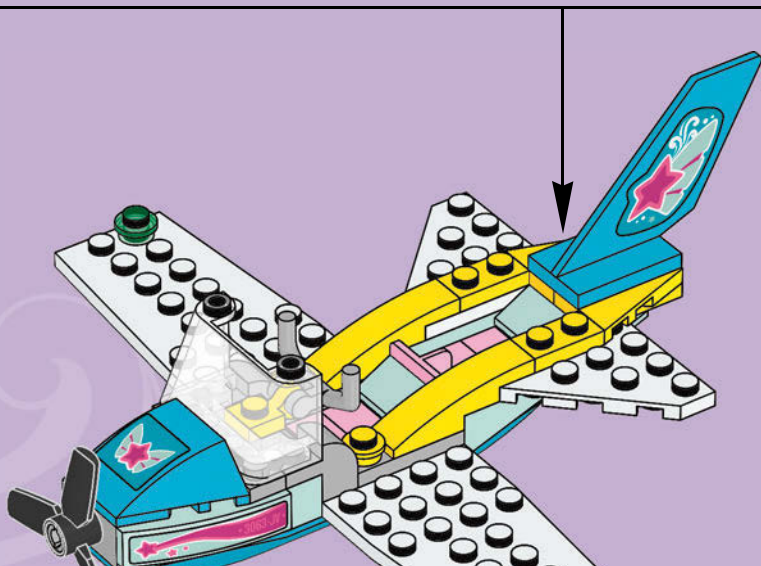

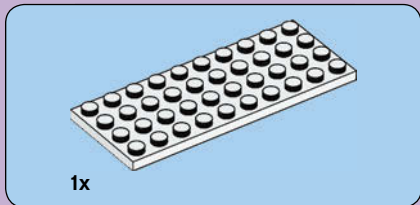
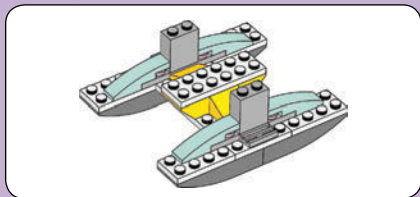

1

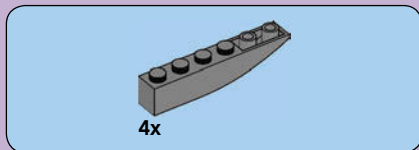
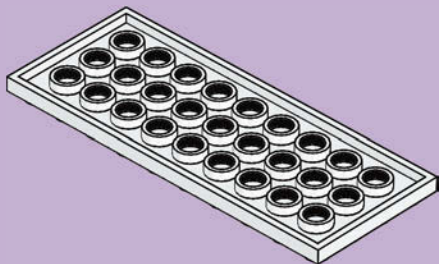

2

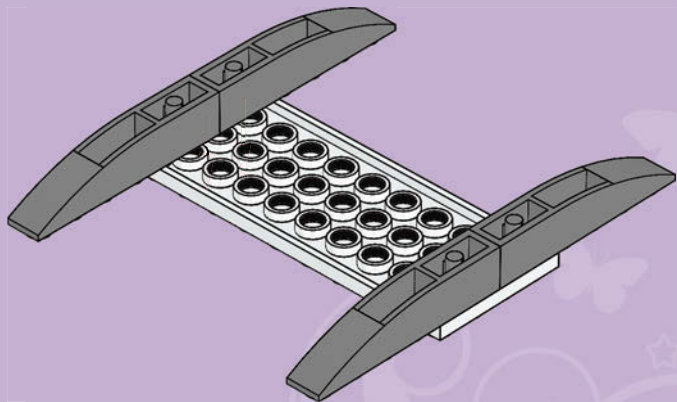

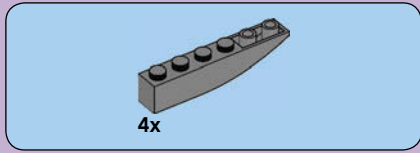

3

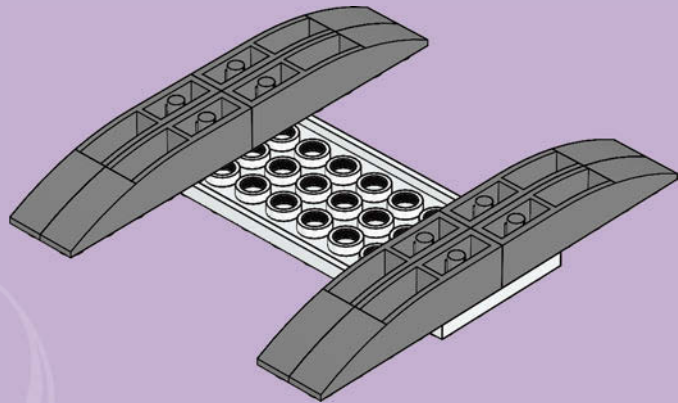



4x

4

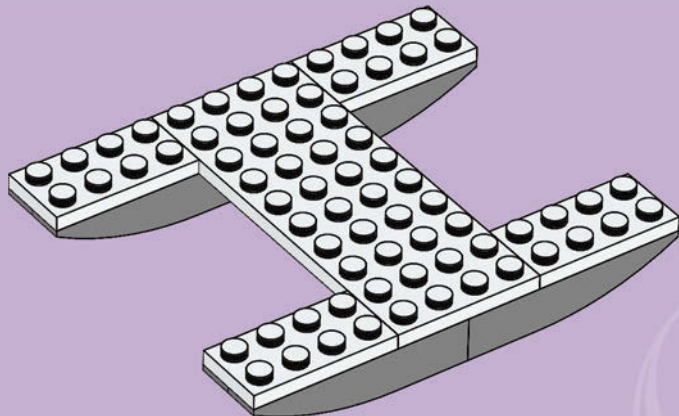
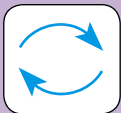

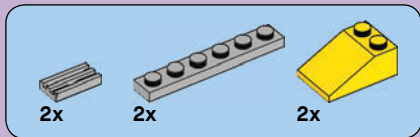

5

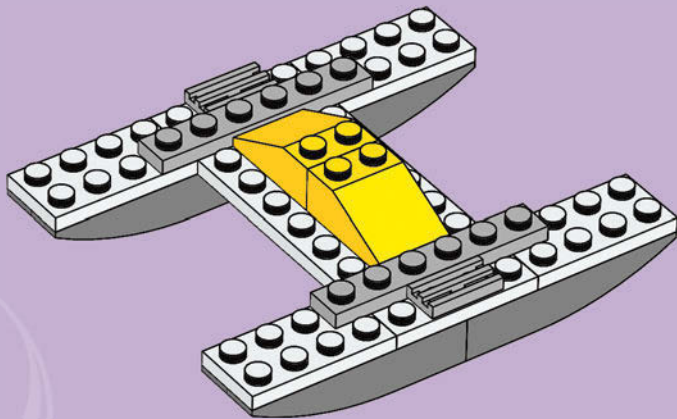



2x

6

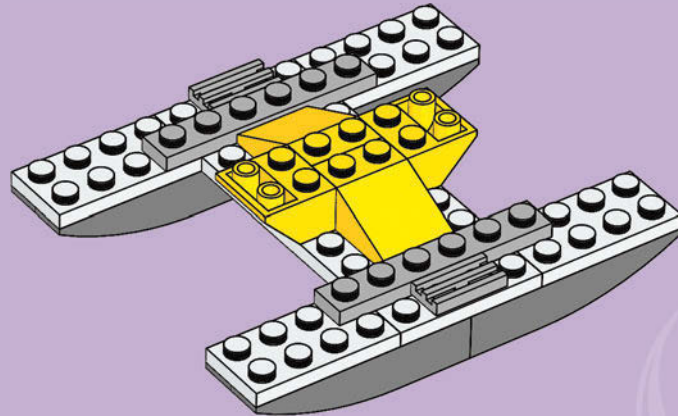



2x



4x

7

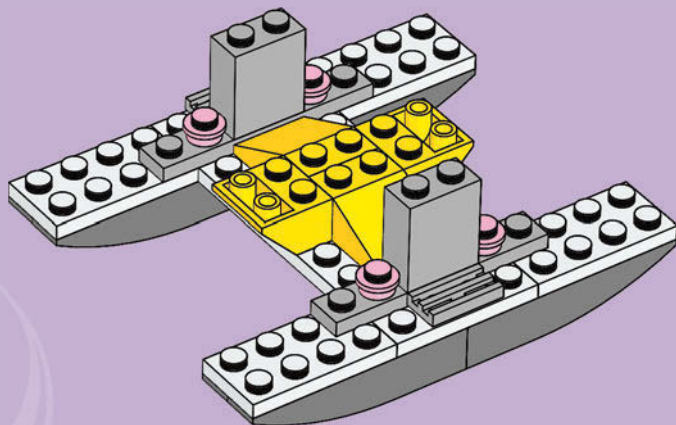

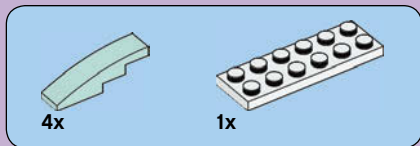

8

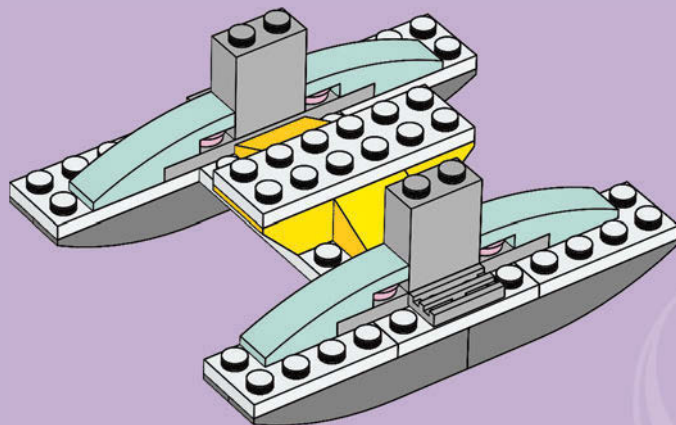

19

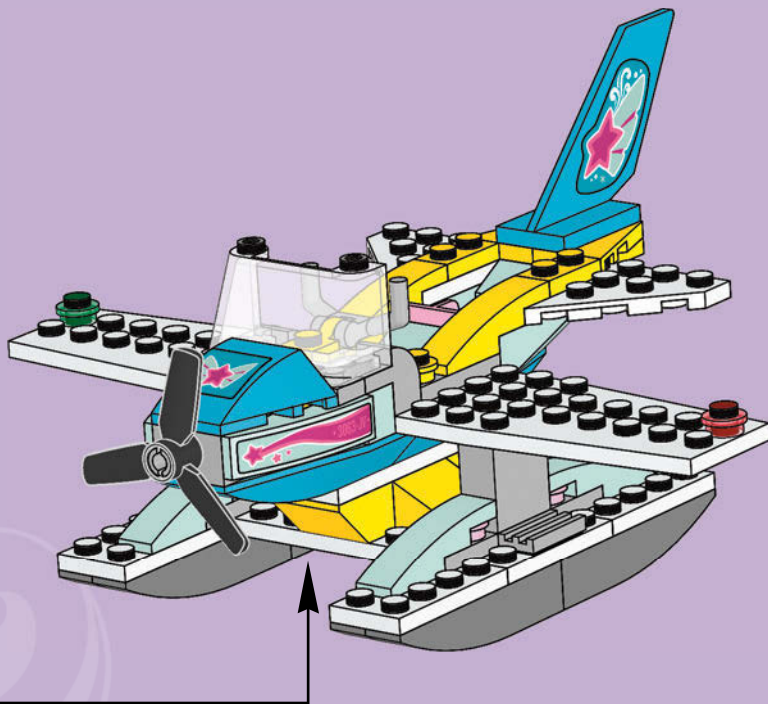



2x

20

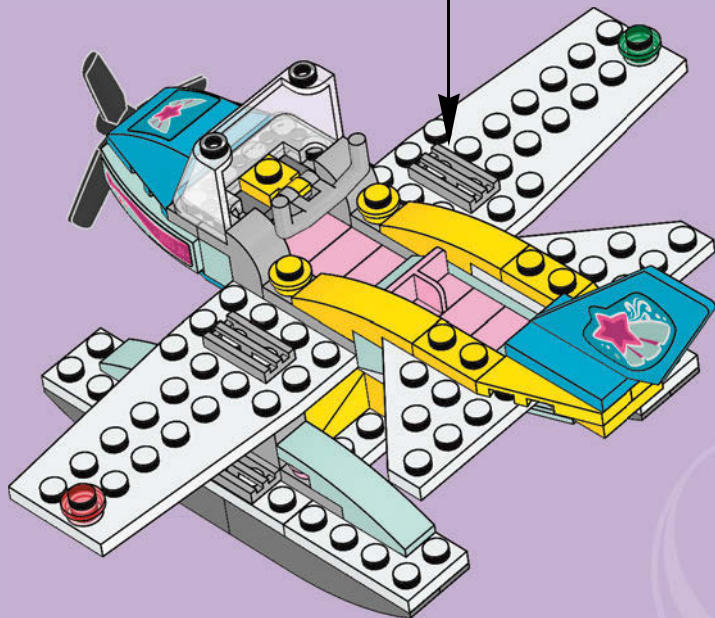
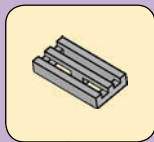

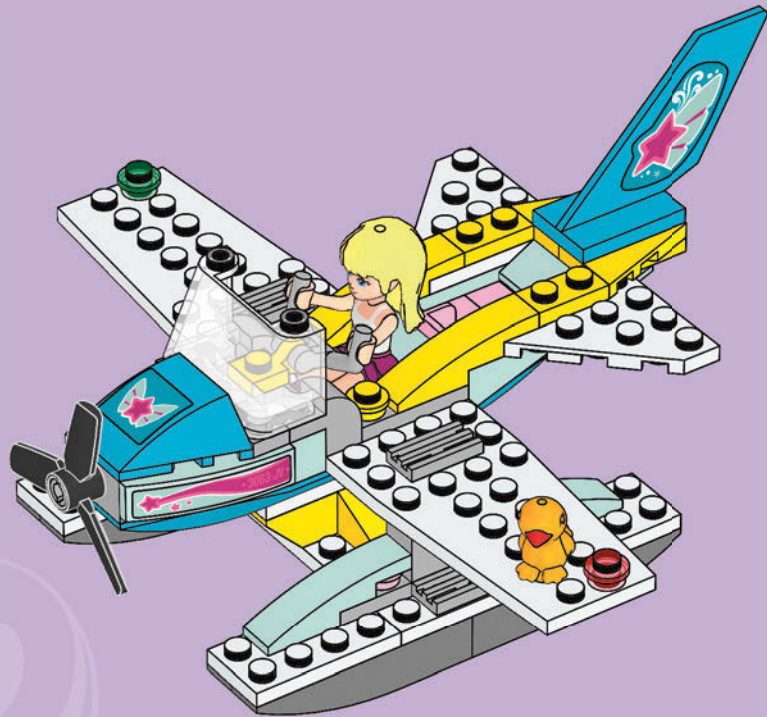

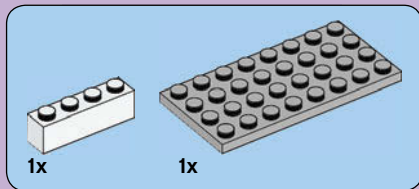
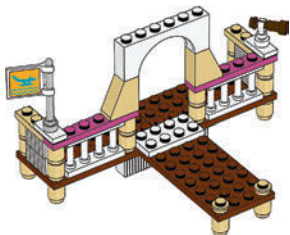

1

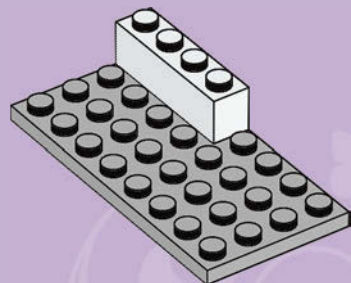

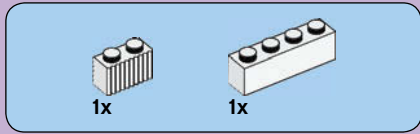

2

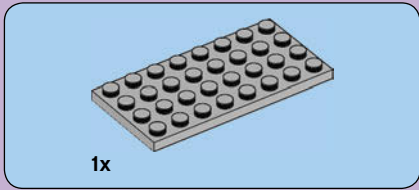
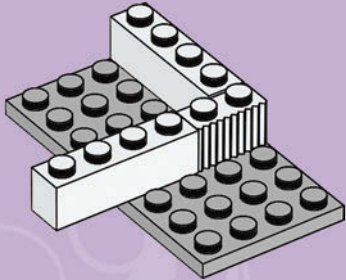

3

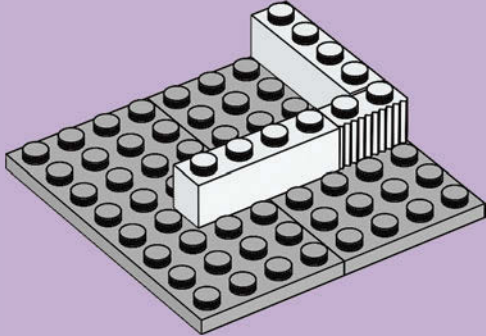



1x



1x

4

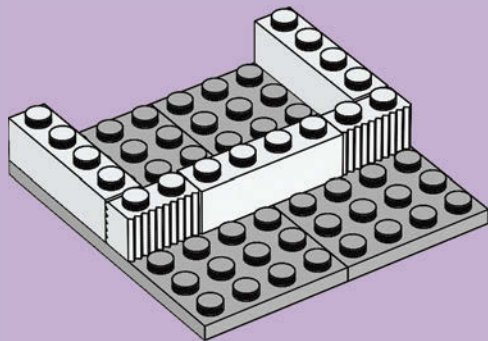

2x



2x

5

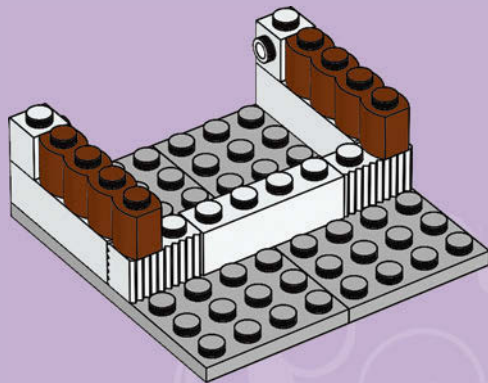

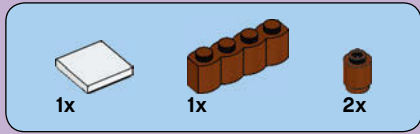

6

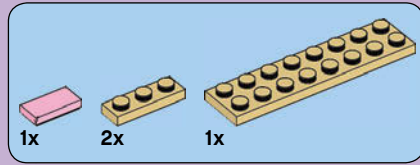
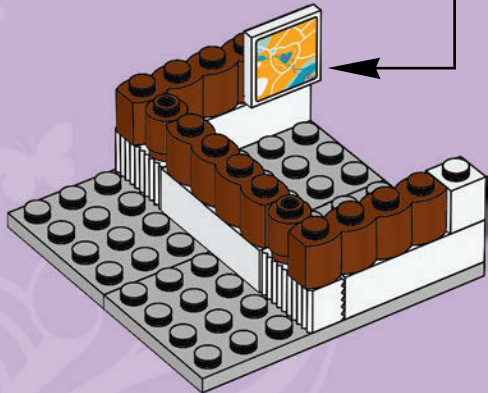
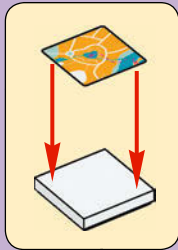

7

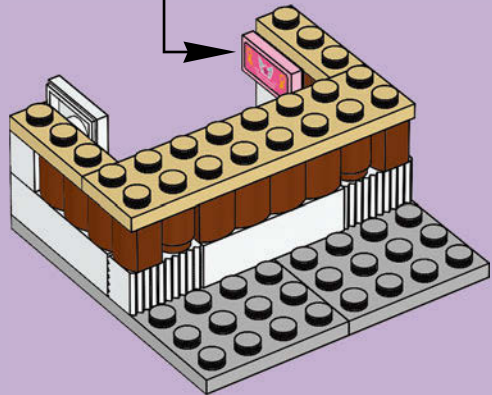

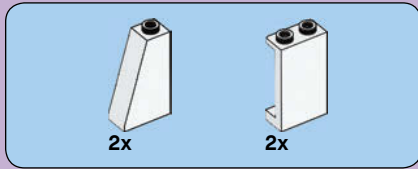

8

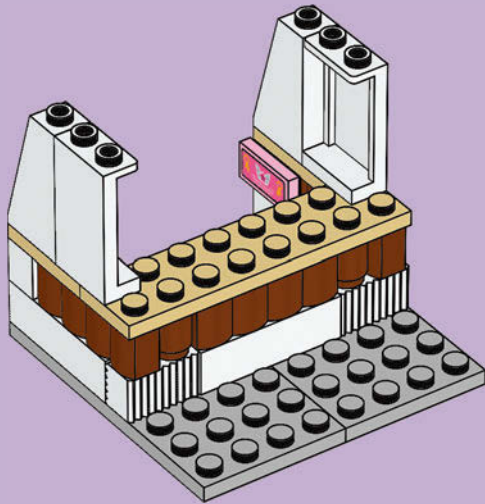

9

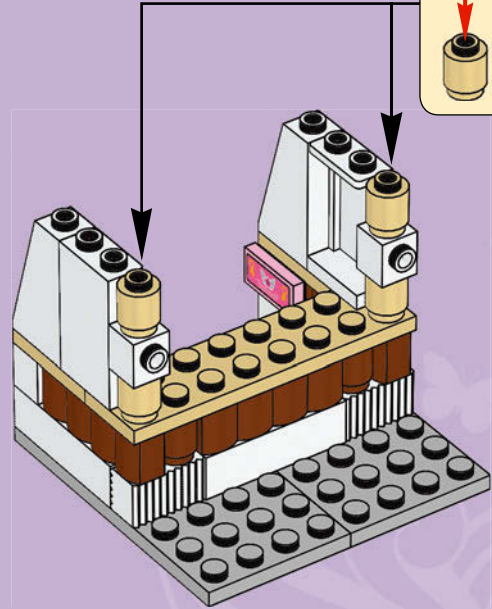
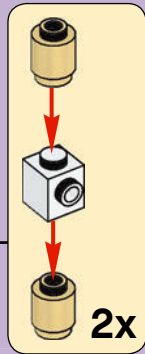



1x



2x

10

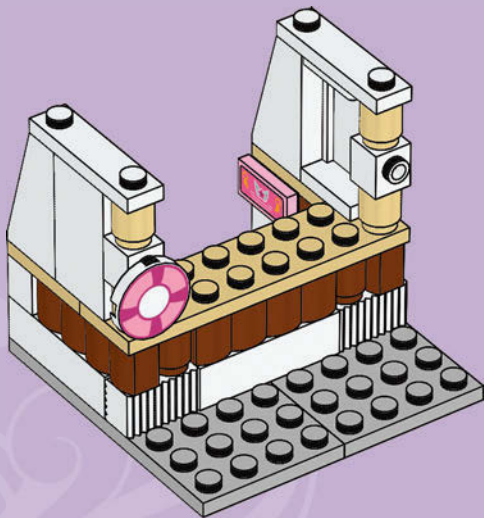

1x

11

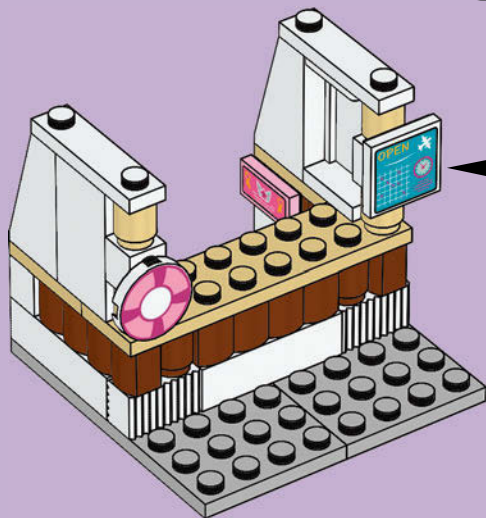



12

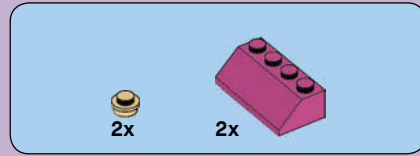
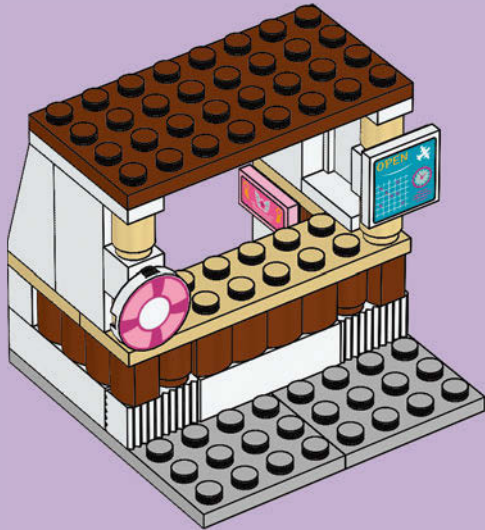

13





1x



2x

14



1x

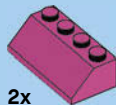

2x

15

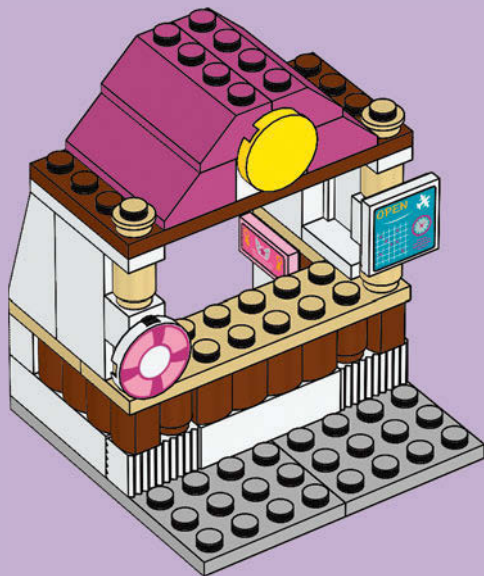



1x



1x

16

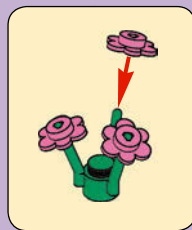

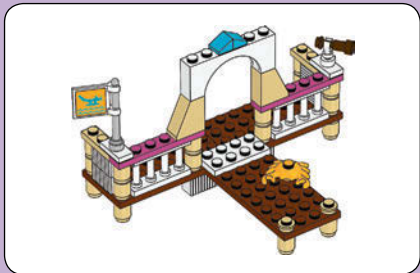

1

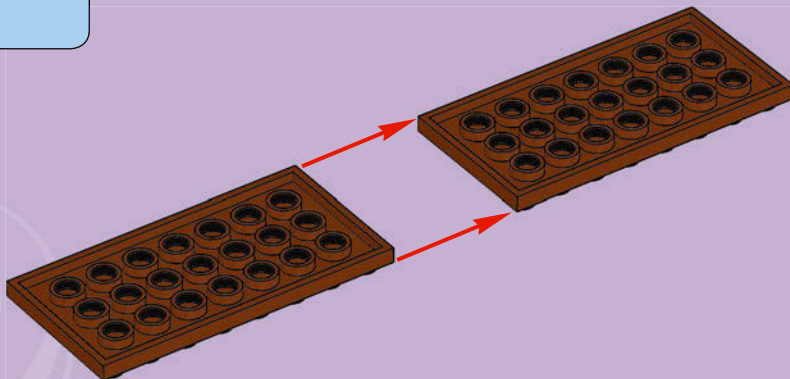

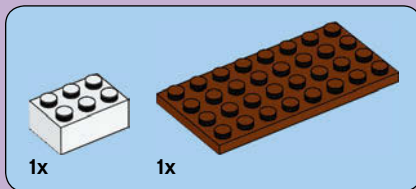

2

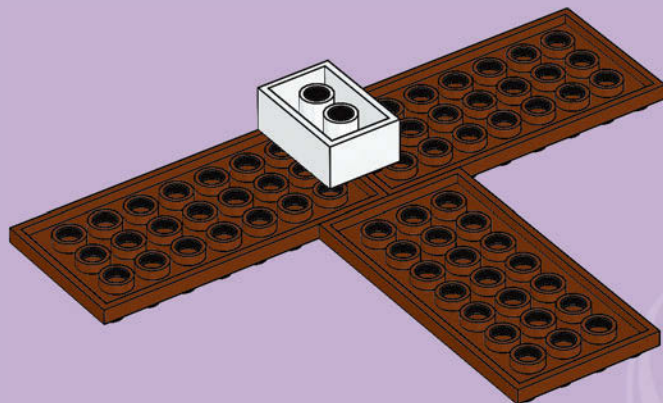



2x



1x

3

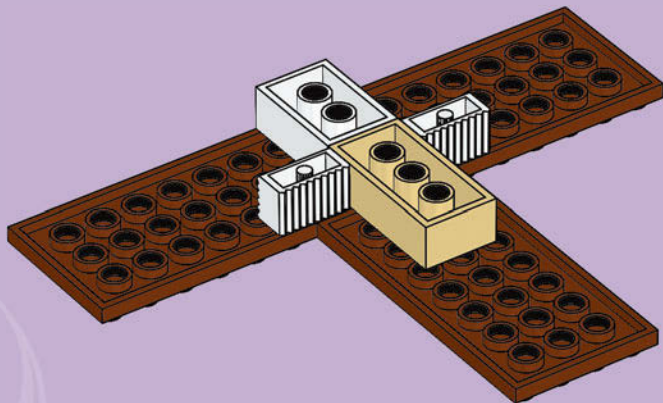



6x

4

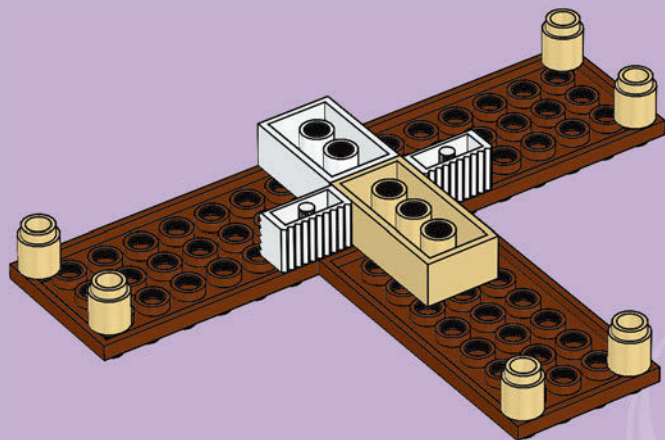



5

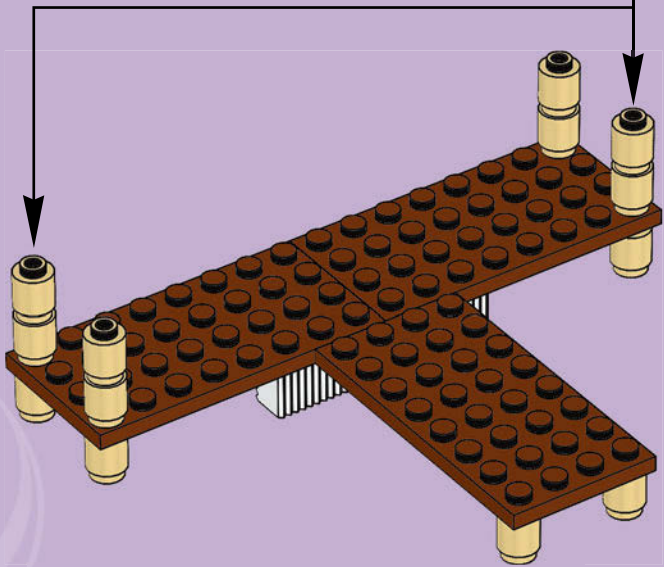
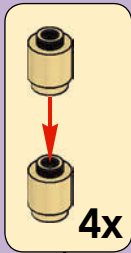

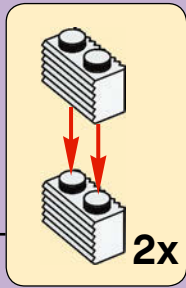
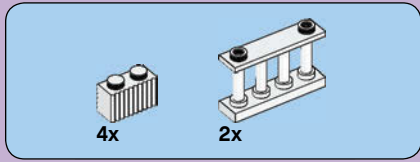

6

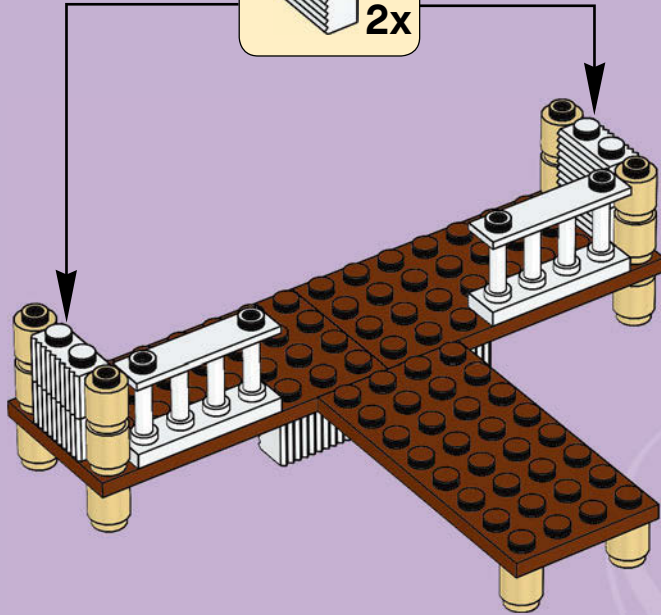



7

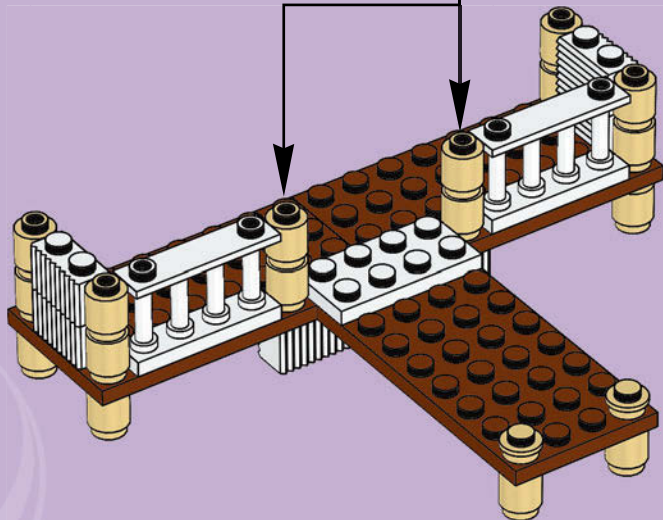
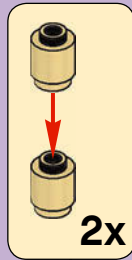

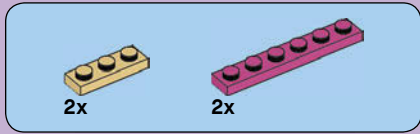

8

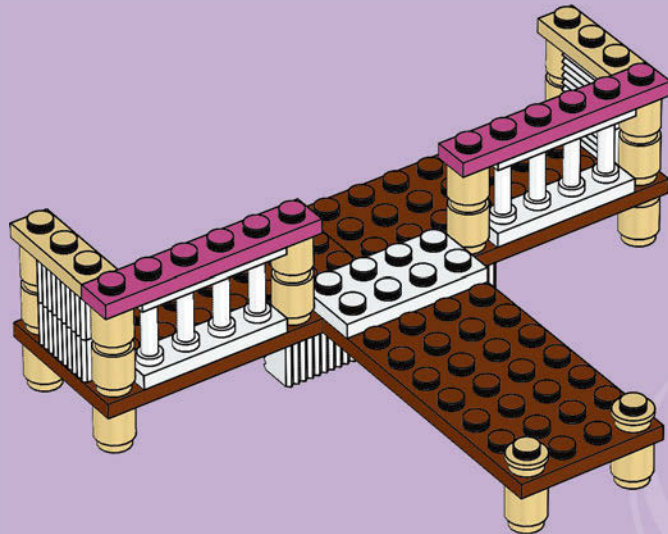

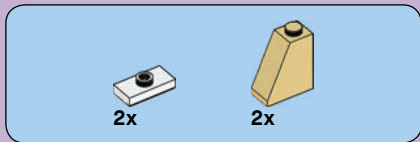

9

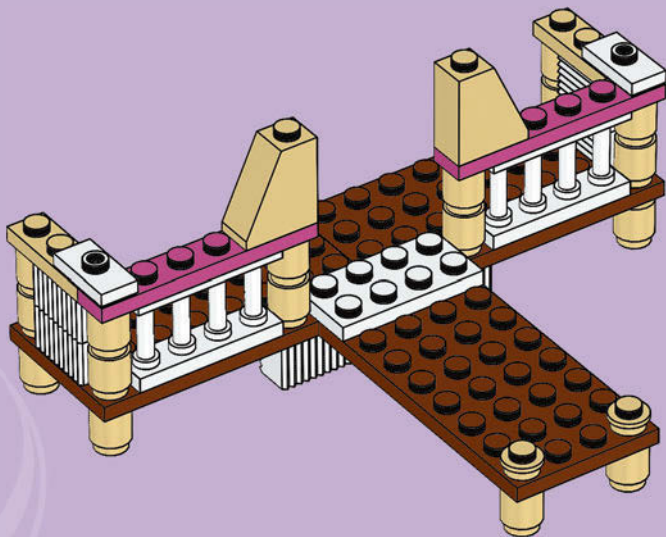

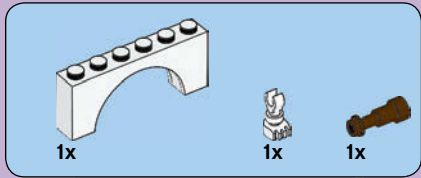

10



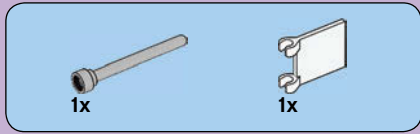

11

1

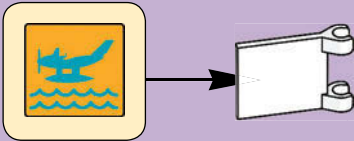

2

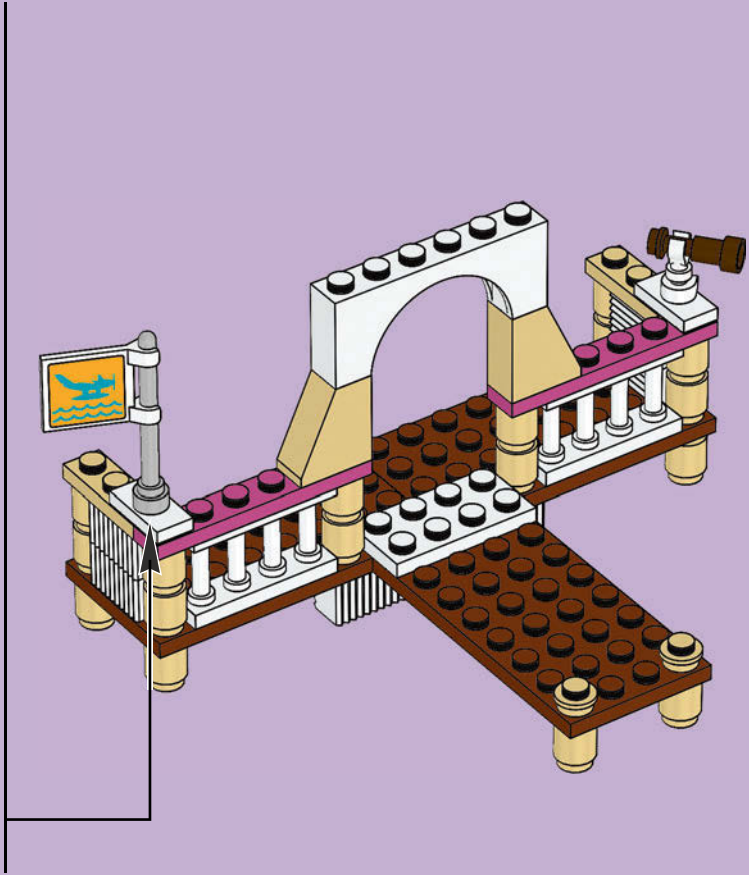
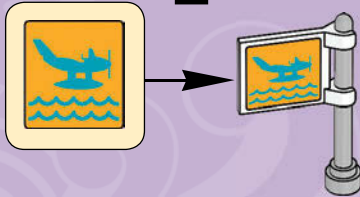



2x



1x

12

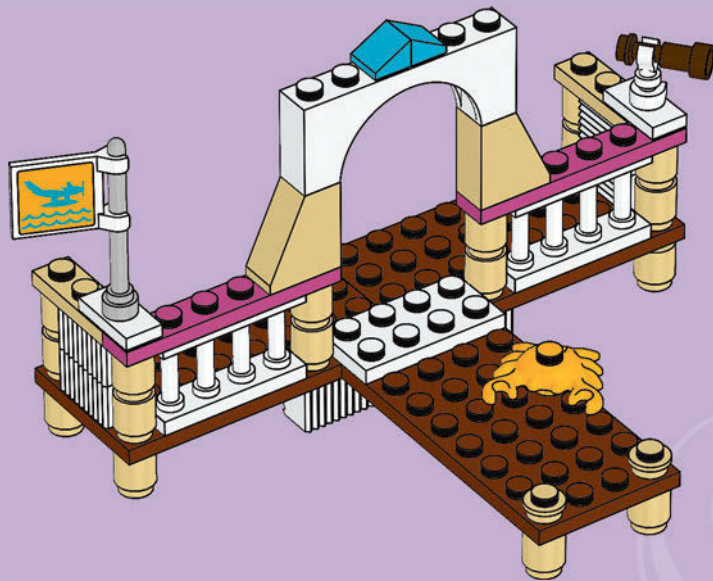

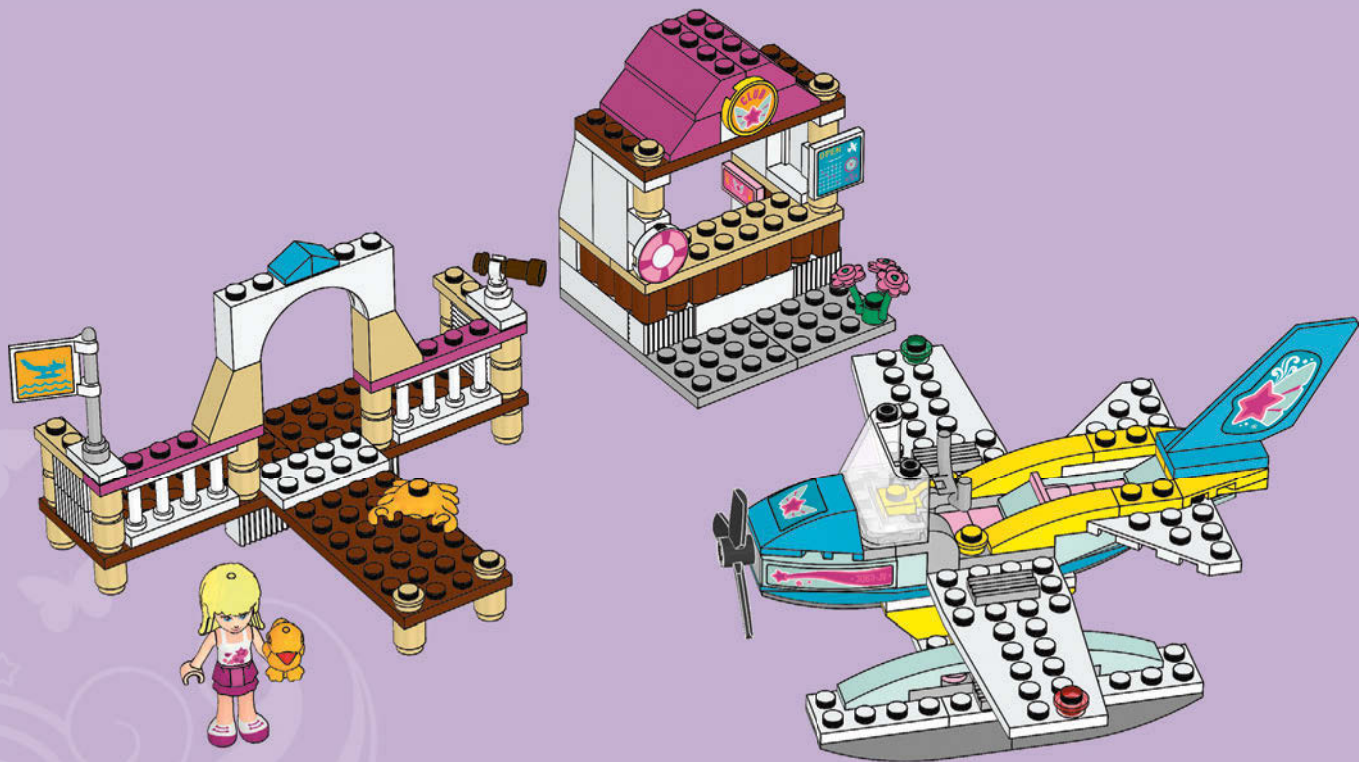



1x
300201



3x
301001



10x
4558952



9x
287701



2x
306801



2x
446001



1x
330701



2x
302301



2x
4597131



6x
302001



1x
379501



2x
379401



2x
4160215



2x
4585448



2x
241301

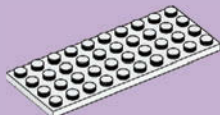

1x
4503008



2x
4519360



1x
6011794



1x
626601



1x
6001510



22x
4117070



1x
4114319



2x
4626200



4x
4121921

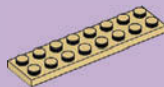

1x
4113988



4x
4161734



1x
300324



2x
366024



2x
329824



2x
4522035



4x
302324



3x
302224



1x
4540040



1x
415024



2x
614124



1x
4179095



1x
4179094



2x
4211438



1x
4211406



2x
4211407



4x
4211350



1x
4211473



1x
4644102



2x
4211564



1x
4211364



2x
4211519



2x
4211353



2x
4211429



1x
4599984



6x
4580010



6x
4517996



1x
4599686



1x
3005748



1x
4596240



1x
6011433



1x
4622859



1x
4622798



1x
3005741



2x
4619520



1x
6002018



2x
4655717

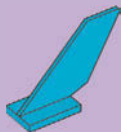

1x
4655245



2x
4630751



2x
4616211

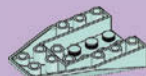

1x
4655720



6x
4655242



1x
382340



4x
4518889



2x
4654105



1x
6005772



1x
4648074



3x
4211181



2x
4211183



4x
4211207



8x
4210779



1x
4211119



1x
4216375



1x
374128



1x
4538950



Customer Service

Kundenservice

Service Consommateurs

Servicio Al Consumidor

www.lego.com/service or dial



00800 5346 5555 :



1-800-422-5346 :





Friends



LEGOFriends.com

Heartlake City



LEGO Friends



3934



3187



3183



3936



3935



3942



3186



3063



3065



3061



3184



Win!

Go to www.LEGOsurvey.com/product to fill out a survey for a chance to win a cool LEGO® Product.
No purchase necessary.
Open to all residents where not prohibited.



www.LEGOsurvey.com/product

Gewinne! Win!

Nimm an der Umfrage auf www.LEGOsurvey.com/product teil und hab die Chance ein cooles LEGO® Produkt zu gewinnen!

Die Teilnahme am Gewinnspiel führt zu keinerlei Kaufverpflichtungen. Teilnahme in allen nicht ausgeschlossenen Ländern möglich.

LEGO and the LEGO logo are trademarks of the/son des marques de commerce de/son marcas registradas de LEGO Group. ©2012 The LEGO Group.

Ga naar www.LEGOsurvey.com/product, vul een enquêteformulier in en maak kans op een cool LEGO® product.

Geen aankoopverplichting. Iedereen mag deelnemen, uitgezonderd ingezetenden van landen waar een enquêteverbod geldt.

Gagne! 当てよう!

Visite www.LEGOsurvey.com/product pour répondre à un questionnaire et avoir une chance de gagner un produit LEGO® très cool!

Aucune obligation d'achat. Ouvert à tous les résidents des pays autorisés.

www.LEGOsurvey.com/product にアクセスして、アンケートにご記入ください。当選者にはレゴ® 製品を差し上げます。

お買い上げの必要はありません。

禁止されていない限り、すべての皆様にご利用いただけます。

6014454 / 6014455



www.LEGO.com