



# Friends



3183

1

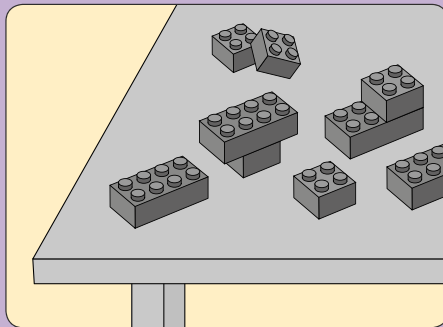
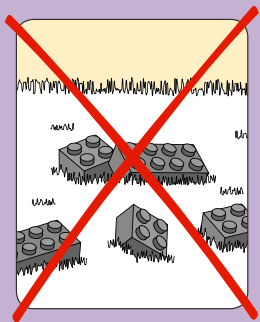

2

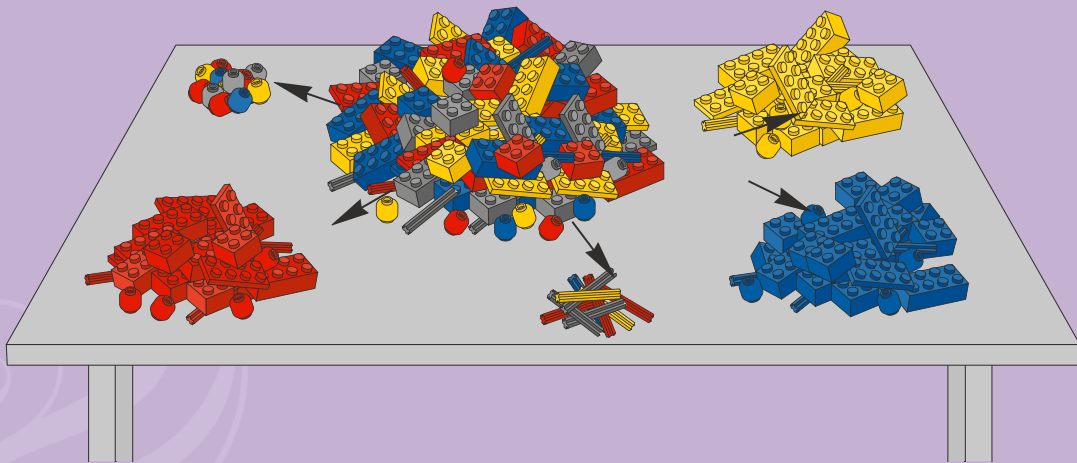

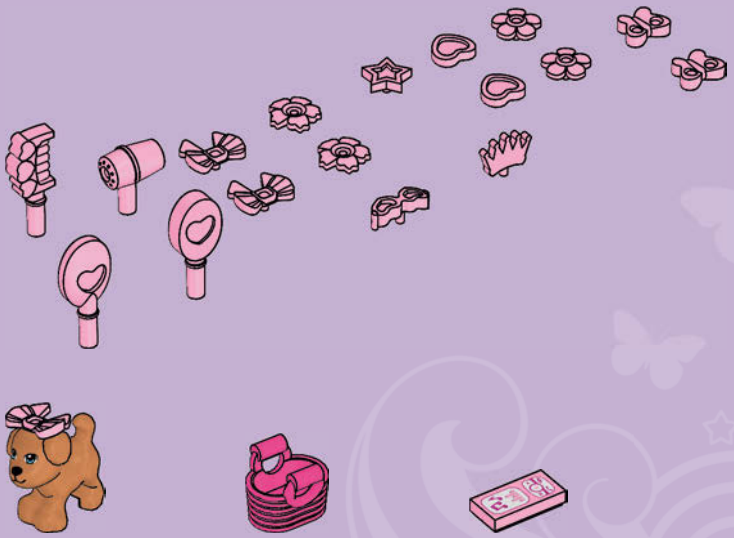
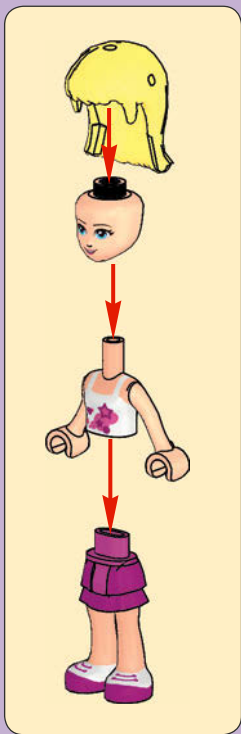

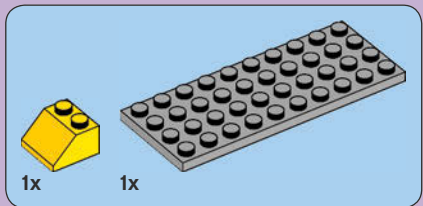
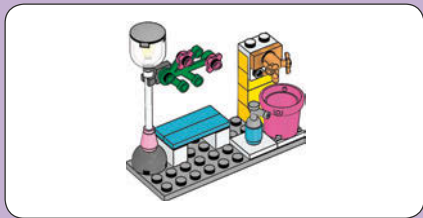

1

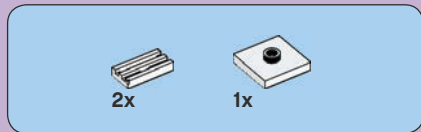
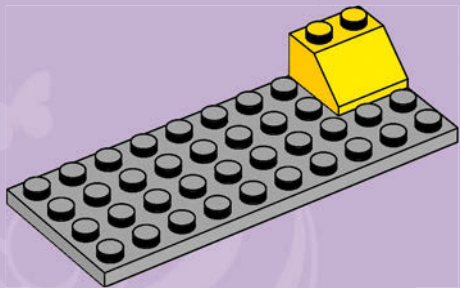

2

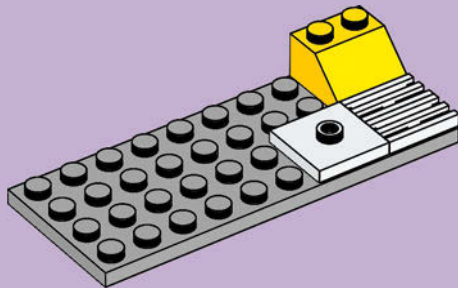



3x

3

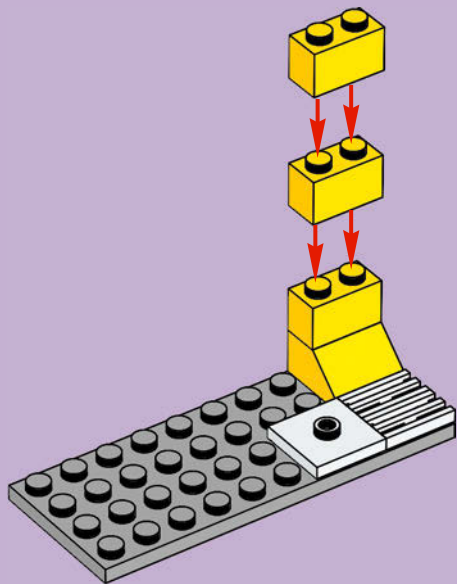

2x



1x

4

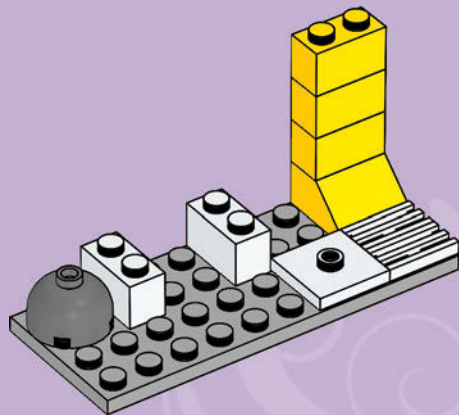



1x



2x

5

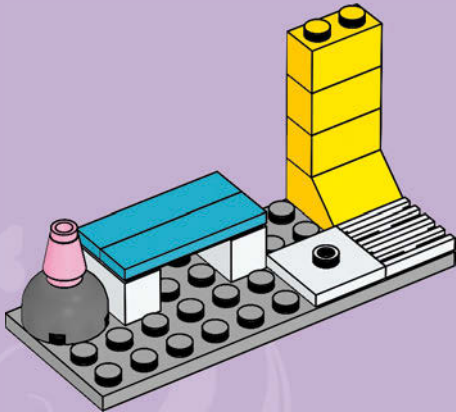

1x



1x

6

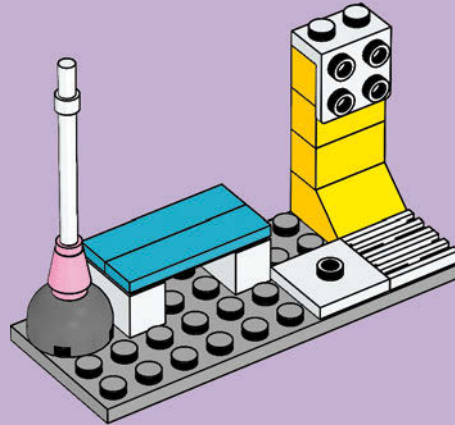



7

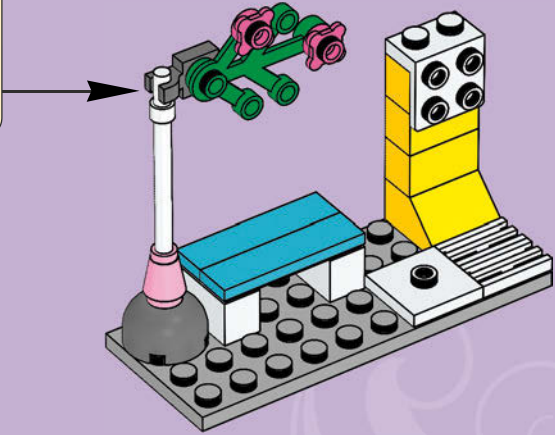
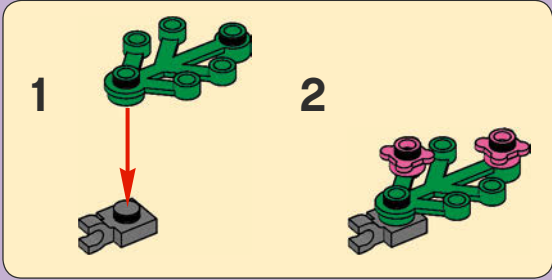



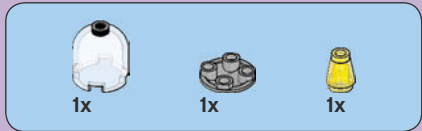

8

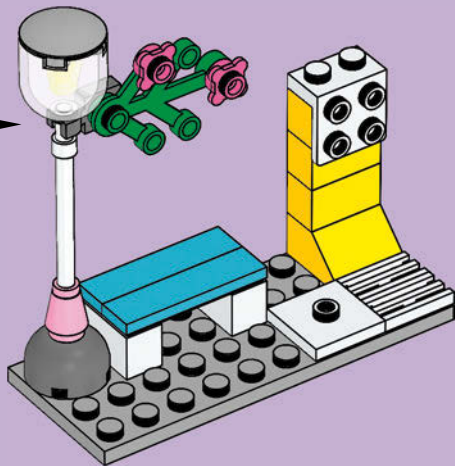





1x



1x

# 9

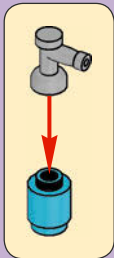
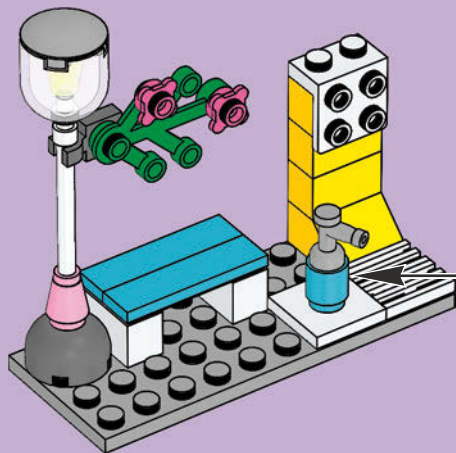

1x



1x

# 10

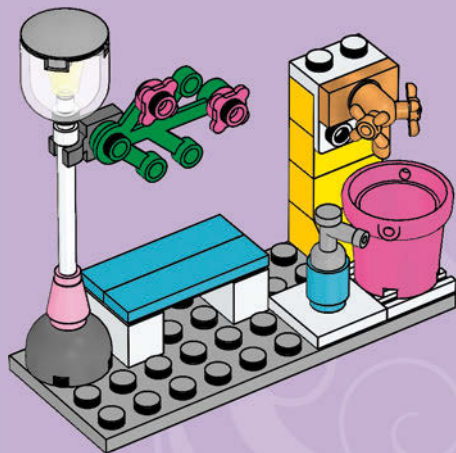

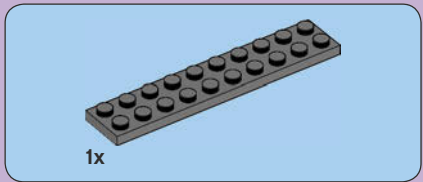

1x

1

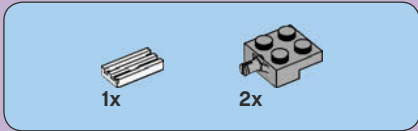
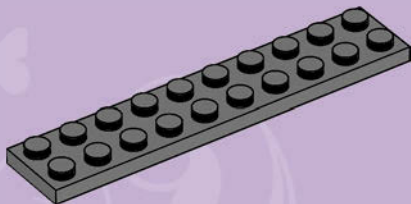

1x

2x

2

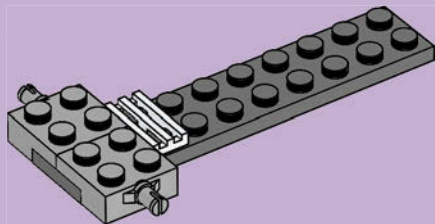

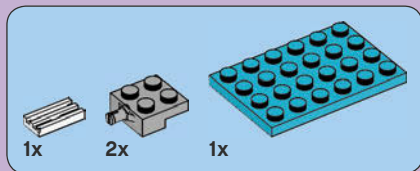

3

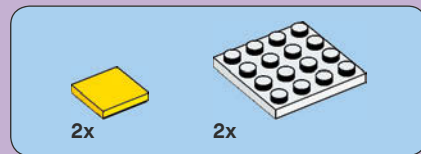
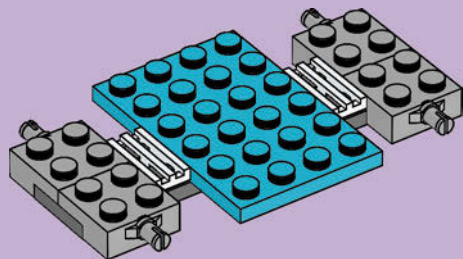

4

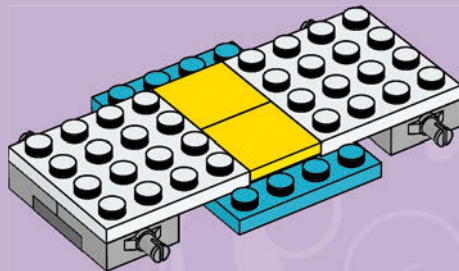

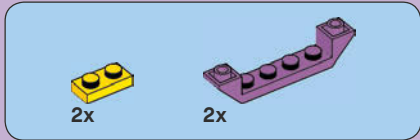

5

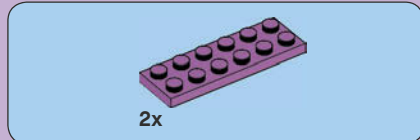
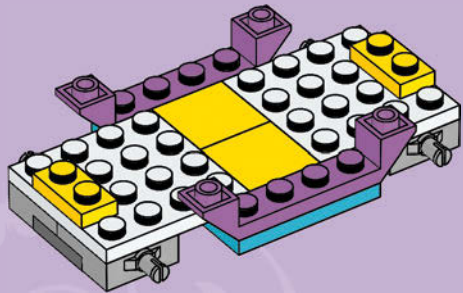

6

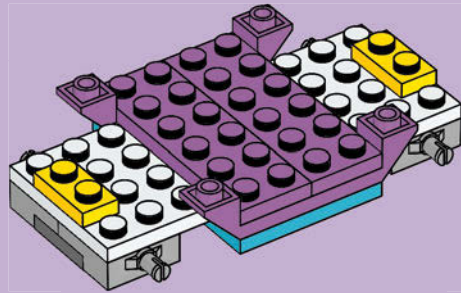



2x

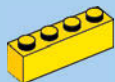

2x

7

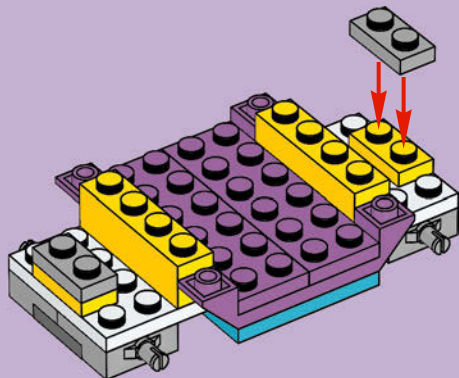

4x

8

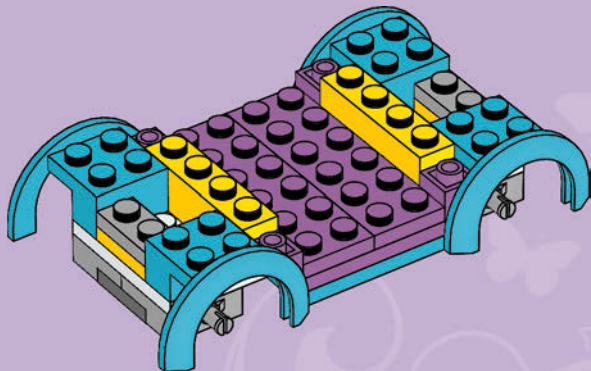



9

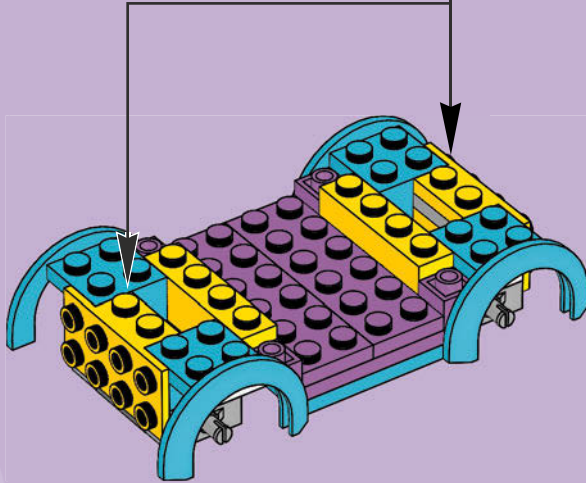
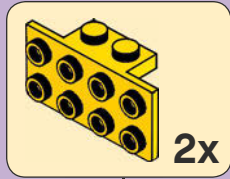



2x



2x

# 10

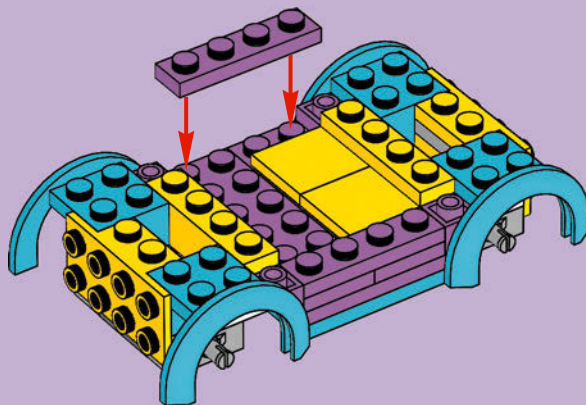





1x



1x

# 11

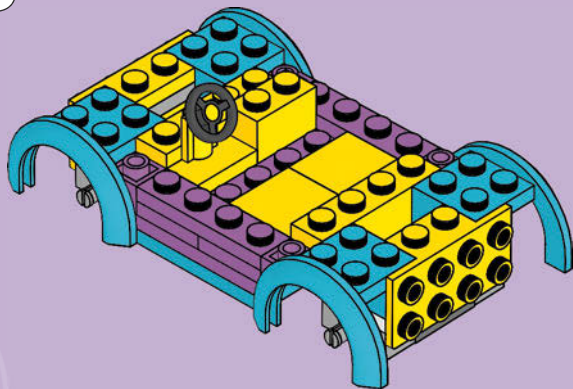
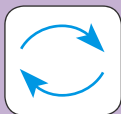



2x

# 12

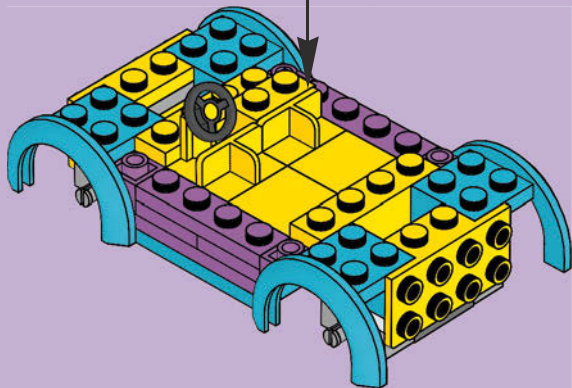
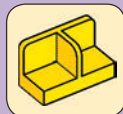

2x

# 13

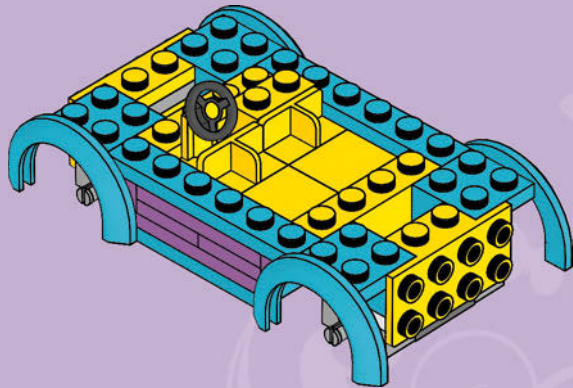



1x

1

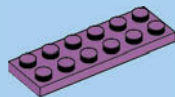

1x

2

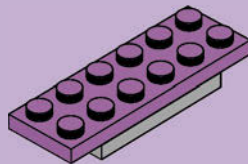

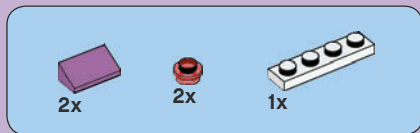

3

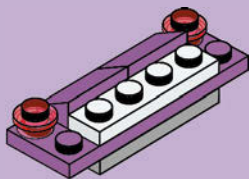

4

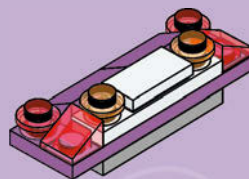

5

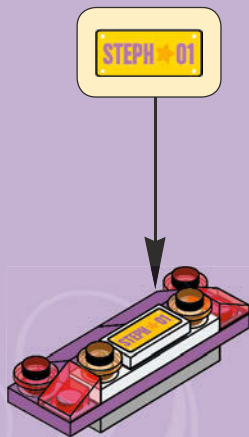

14

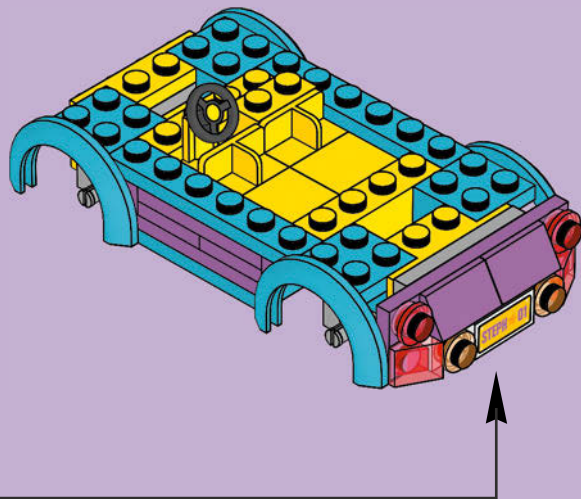

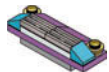

1x

1

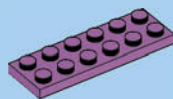
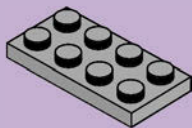

1x

2

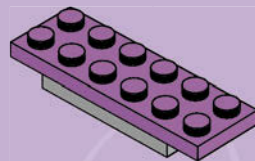



2x



2x

3

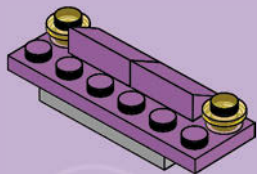

1x



2x

4

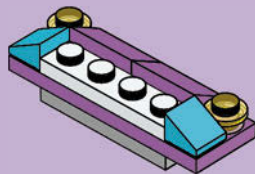





2x

5

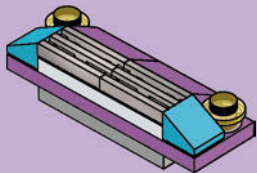

15

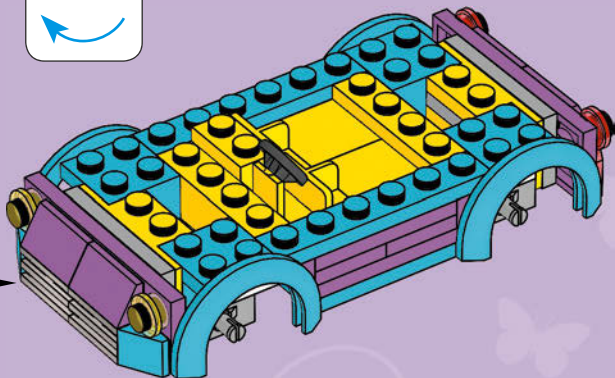
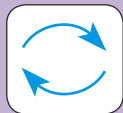

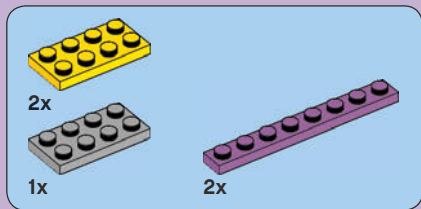

16

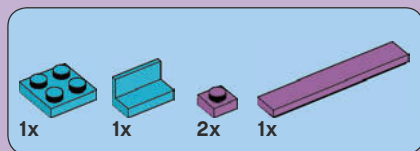
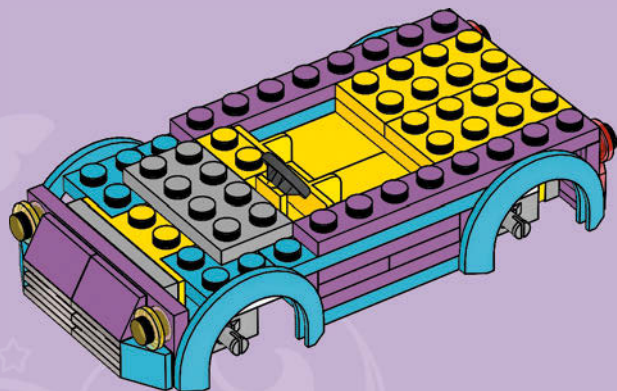

17

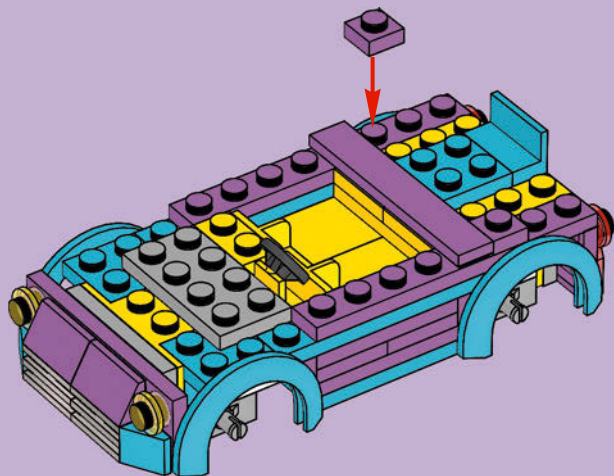



2x



2x

# 18

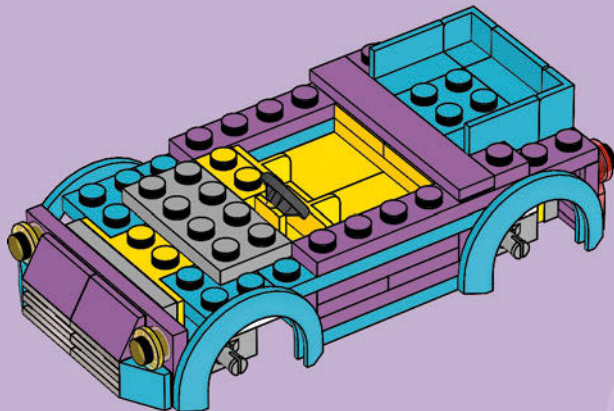



2x

19

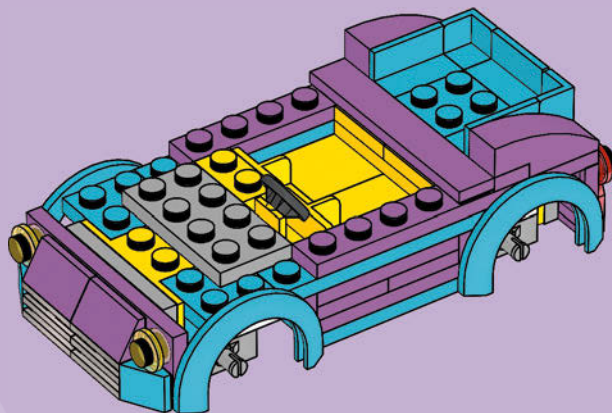



1x



2x



2x

# 20

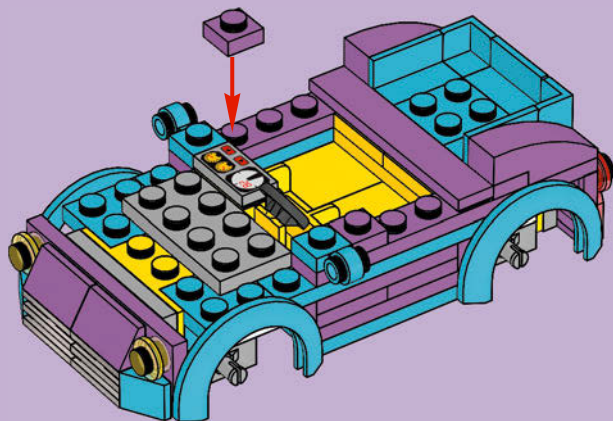

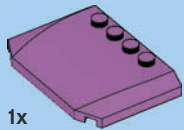

1x

21

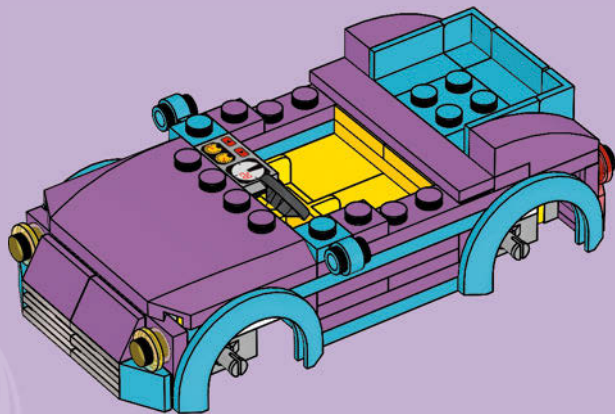

22

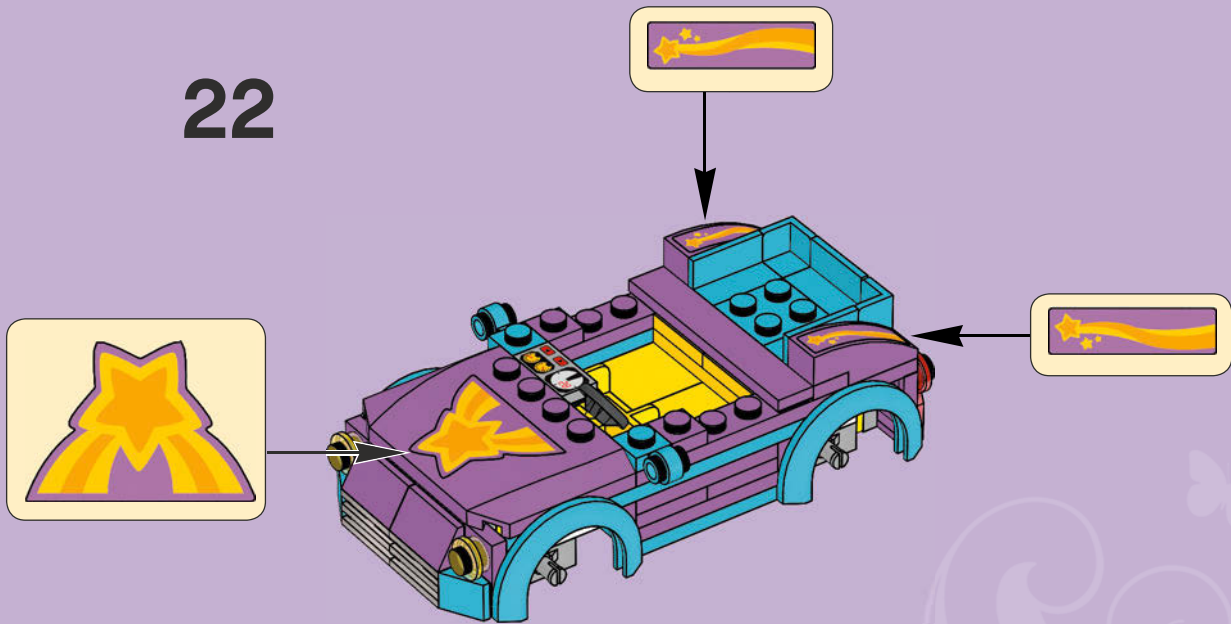



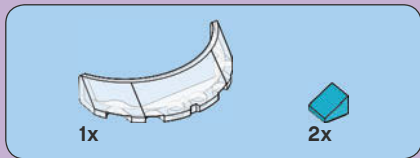

23

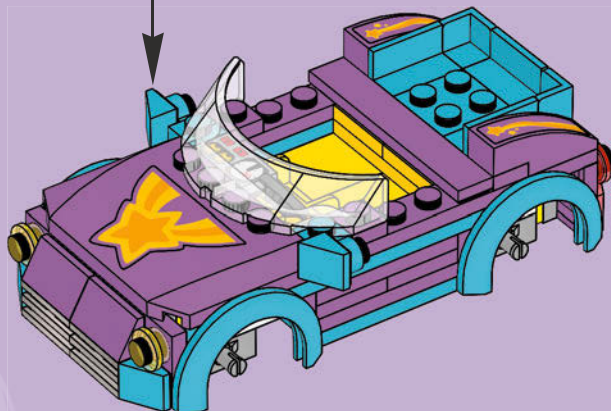
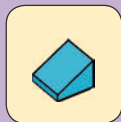

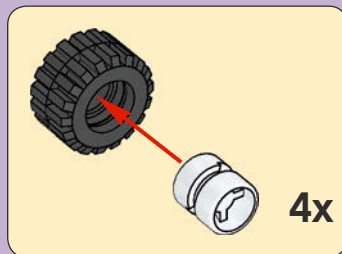
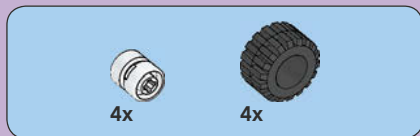

24

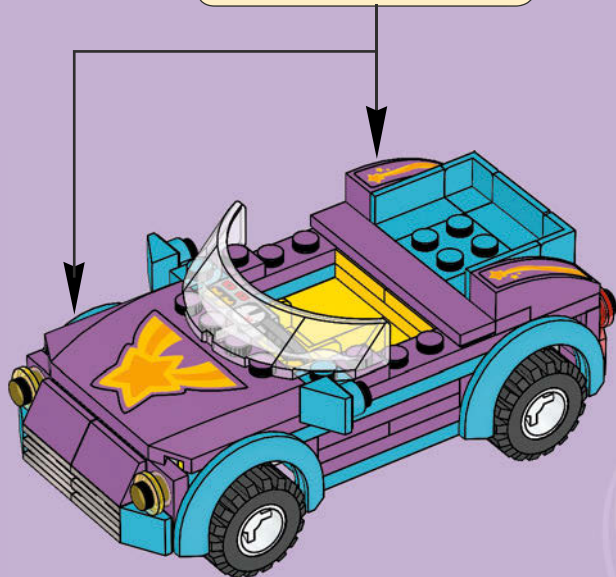

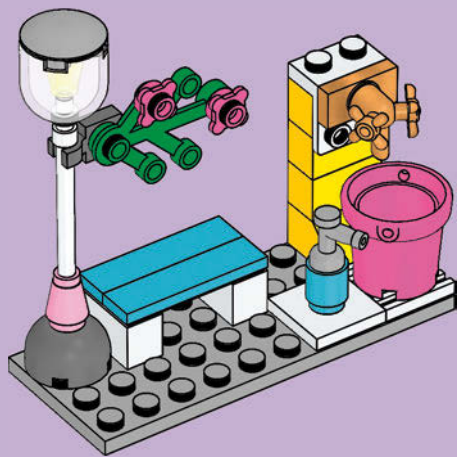
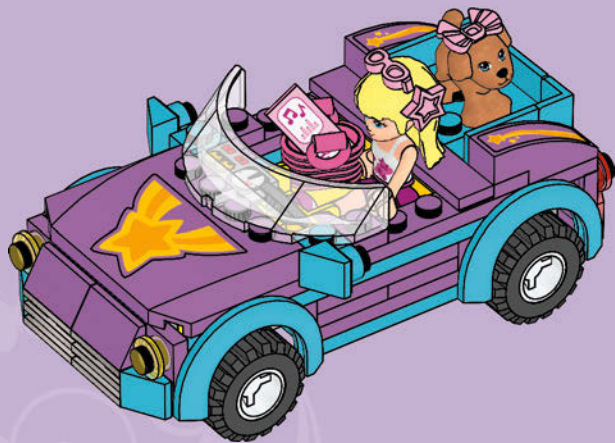



Customer Service  
Kundenservice  
Service Consommateurs  
Servicio Al Consumidor

[www.lego.com/service](http://www.lego.com/service) or dial



: 00800 5346 5555

: 1-800-422-5346



# Friends

LEGOFriends.com



Emma



Olivia



Stephanie



Mia



Andrea





3183



3061



3187



3932



3065



3942



3935



3933



3188



3936



3315

# Heartlake City

 Friends





LEGO Friends



LEGOFriends.com





# CREATOR

5766



5771



5770



creator.LEGO.com







[www.LEGOclub.com](http://www.LEGOclub.com)



**LEGO club**

**FREE! GRATIS! GRATUIT!**

**SIGN UP ONLINE!**

**[www.LEGOclub.com](http://www.LEGOclub.com)**



**00800 5346 5555\***



**1-866-534-6258 • 1-877-518-5346**

US & Canada only

Canada seulement

- \* Freephone. Mobile charges may apply.
- \* Numéro sans frais. Des frais peuvent s'appliquer avec les téléphones cellulaires.
- \* Gebührenfrei, Kosten für Anrufe aus Mobilfunknetzen können abweichen.
- \* Gratis telefonnummer vanaf vaste lijn.
- \* Det er et gratis nummer, når du ringer fra fasttelefon.
- \* Det är gratis, när du ringer från en fast telefon.
- \* Numéro sans frais. Des frais peuvent s'appliquer avec les téléphones portables.



# Win!

Go to [www.LEGOsurvey.com/product](http://www.LEGOsurvey.com/product) to fill out a survey for a chance to win a cool LEGO® Product. No purchase necessary. Open to all residents where not prohibited.



## [www.LEGOsurvey.com/product](http://www.LEGOsurvey.com/product)

### Gewinne!

Nimm an der Umfrage auf [www.LEGOsurvey.com/product](http://www.LEGOsurvey.com/product) teil und hab die Chance ein cooles LEGO® Produkt zu gewinnen!

Die Teilnahme am Gewinnspiel führt zu keinerlei Kaufverpflichtungen. Teilnahme in allen nicht ausgeschlossenen Ländern möglich.



[www.LEGO.com](http://www.LEGO.com)

6006117

### Win!

Ga naar [www.LEGOsurvey.com/product](http://www.LEGOsurvey.com/product), vul een enquêteformulier in en maak kans op een cool LEGO® product.

Geen aankoopverplichting. Iedereen mag deelnemen, uitgezonderd ingezetenden van landen waar een enquêteverbod geldt.

### Gagne!

Visite [www.LEGOsurvey.com/product](http://www.LEGOsurvey.com/product) pour répondre à un questionnaire et avoir une chance de gagner un produit LEGO® très cool!

Aucune obligation d'achat. Ouvert à tous les résidents des pays autorisés.

### 当てよう!

[www.LEGOsurvey.com/product](http://www.LEGOsurvey.com/product) にアクセスして、アンケートにご記入ください。当選者にはレゴ®製品を差し上げます。

お買い上げの必要はありません。禁止されていない限り、すべての皆様にご利用いただけます。