



THE HOBBIT™

AN UNEXPECTED JOURNEY

79003





[LEGO.com/brickseparator](https://www.LEGO.com/brickseparator)

LEGO THE HOBBIT™
AN UNEXPECTED JOURNEY

LEGO LE HOBBIT™
UN VOYAGE INATTENDU

LEGO EL HOBBIT™
UN VIAJE INESPERADO



1

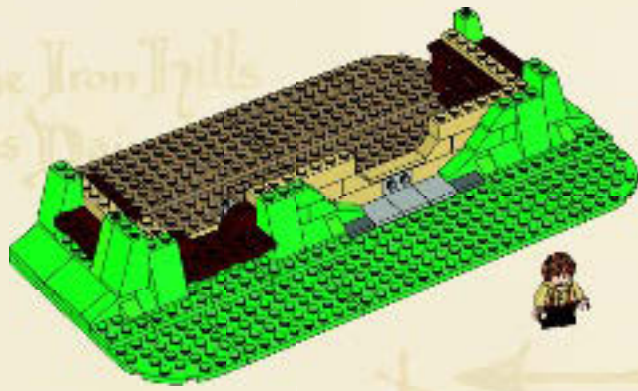

2

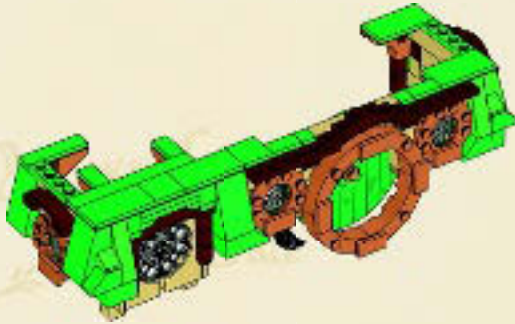

3



4



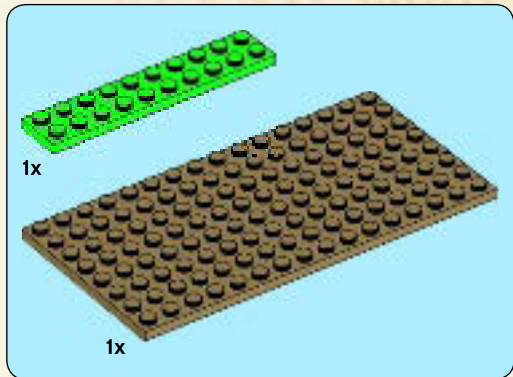
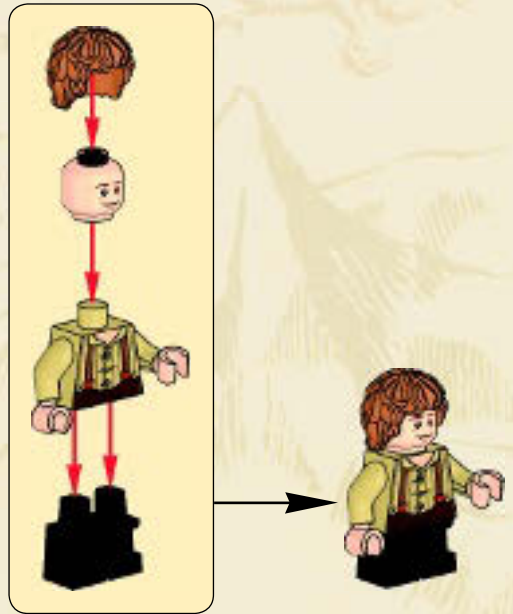
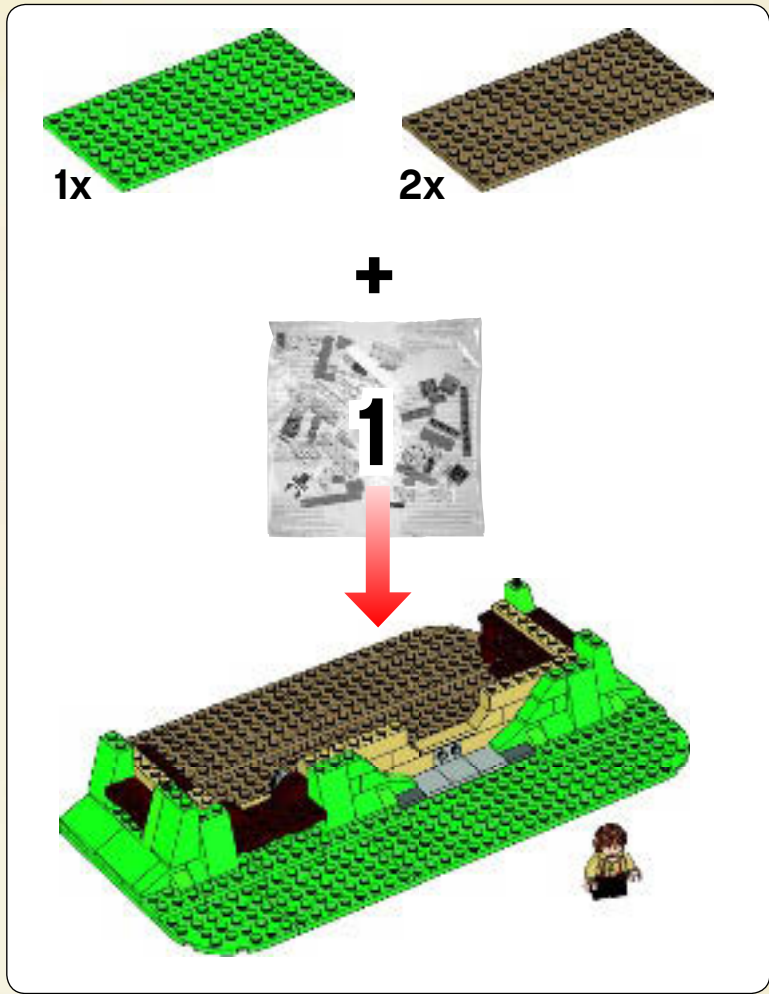

1

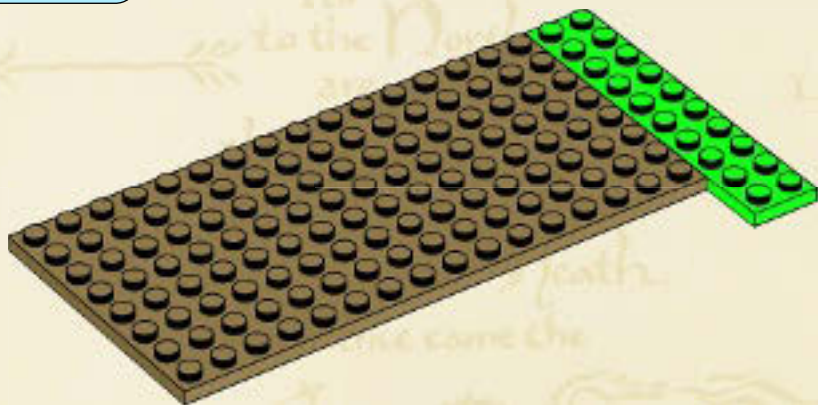

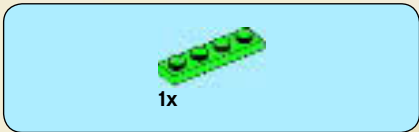

2

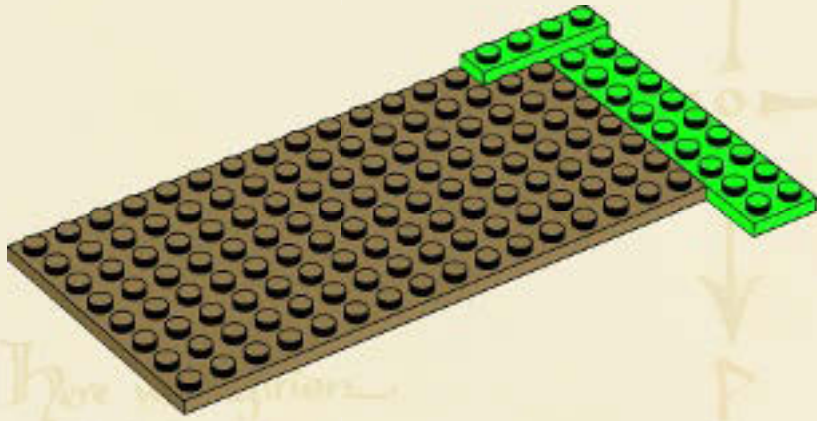

3

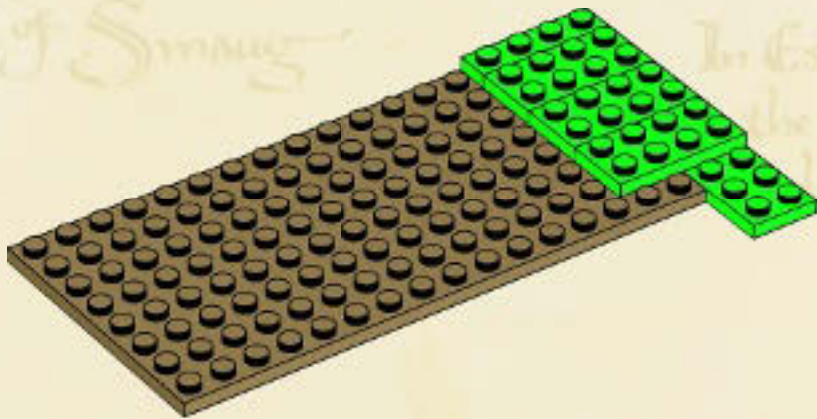



1x

4

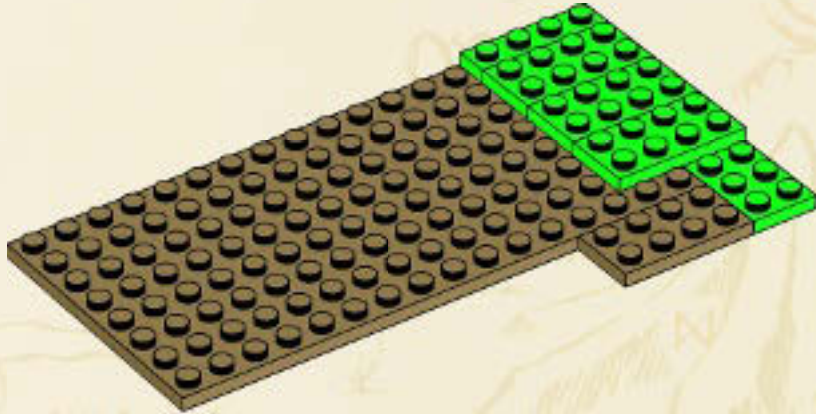

1x

5

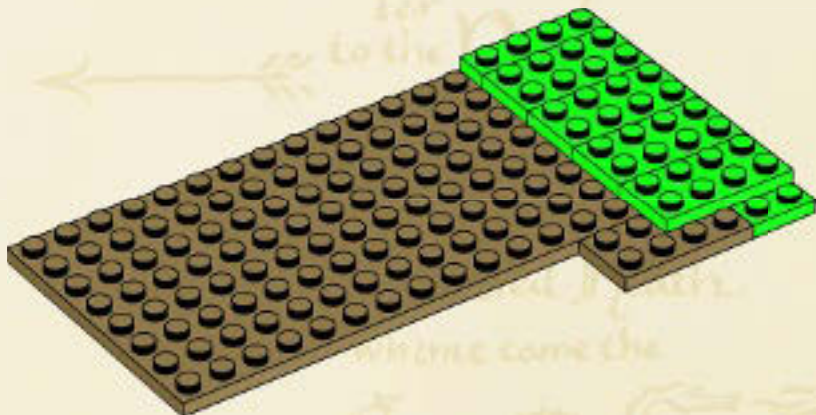

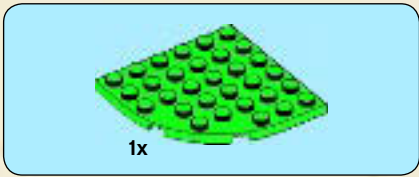

6

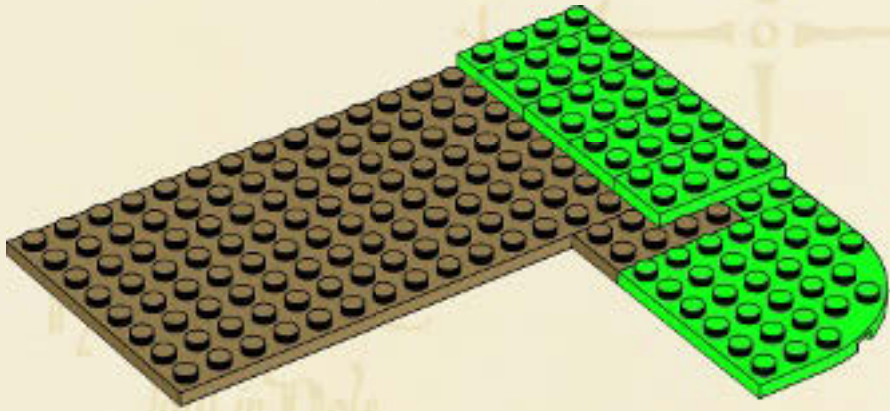

7

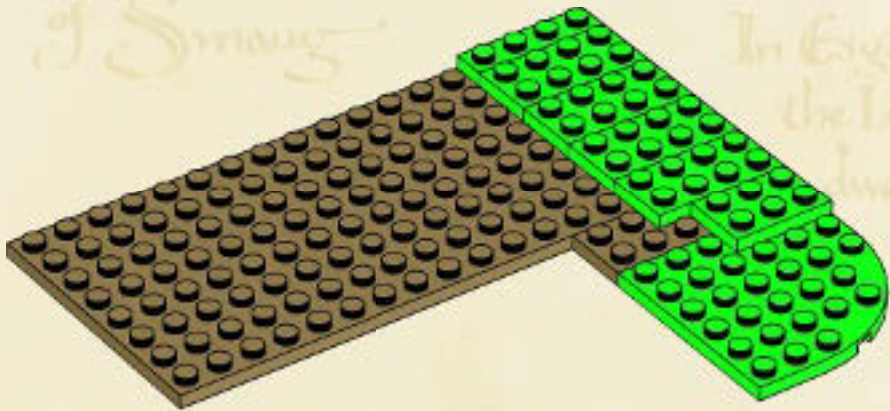

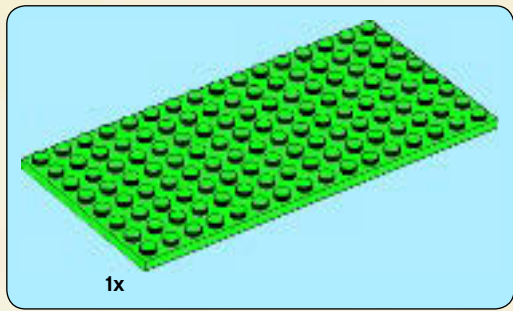

8

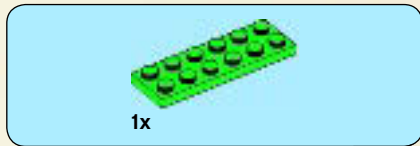
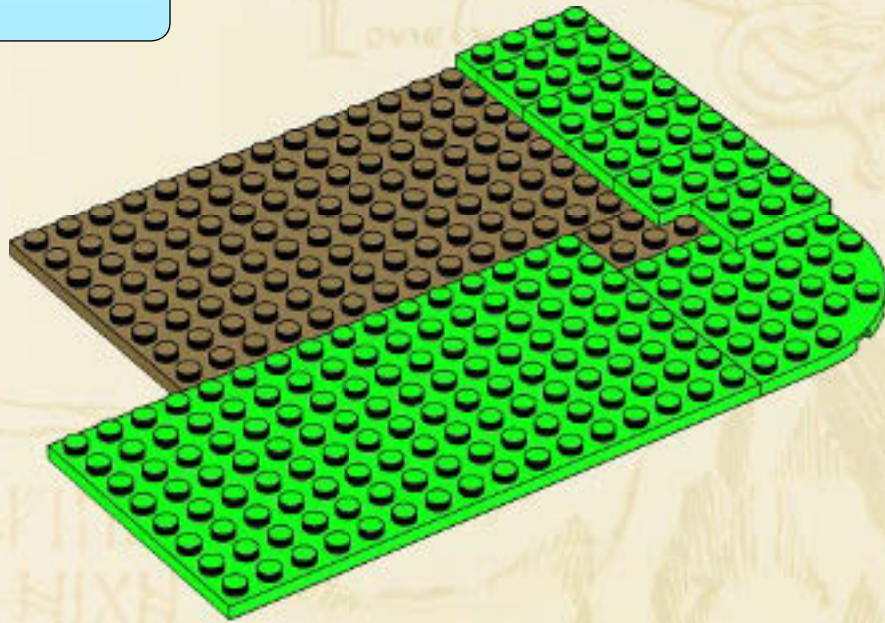

9

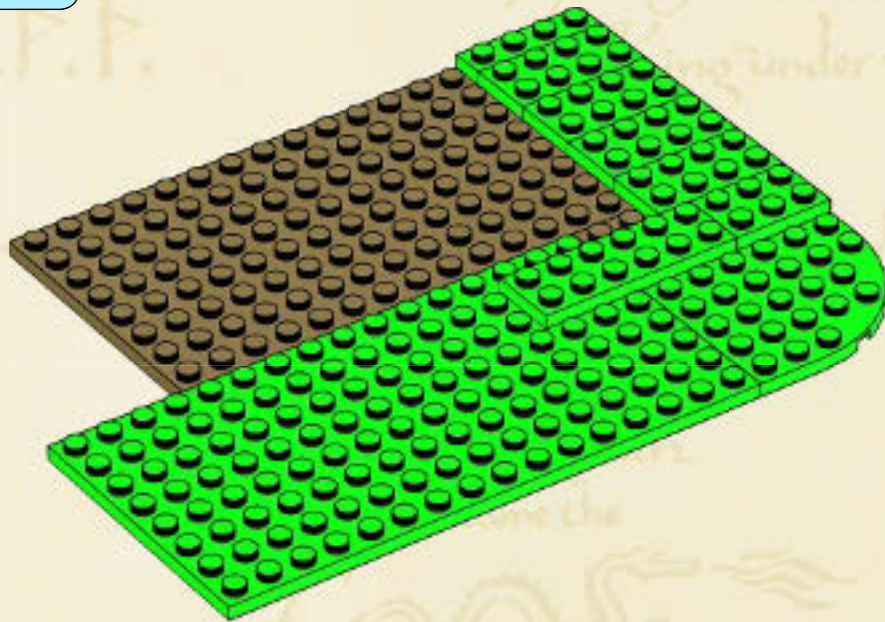

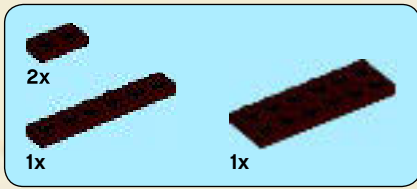

10

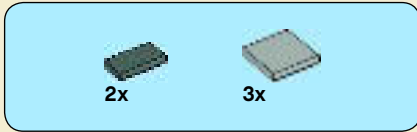
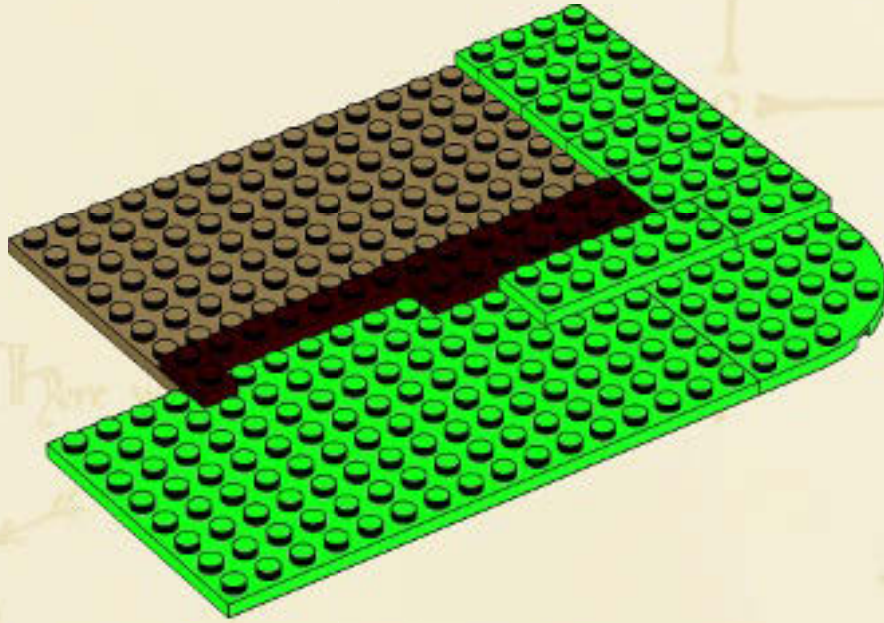

11

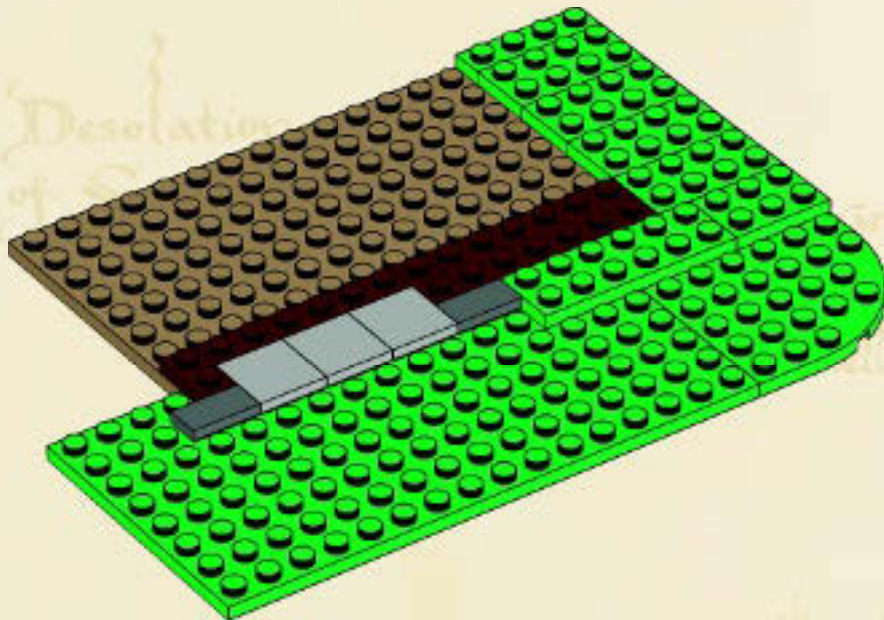

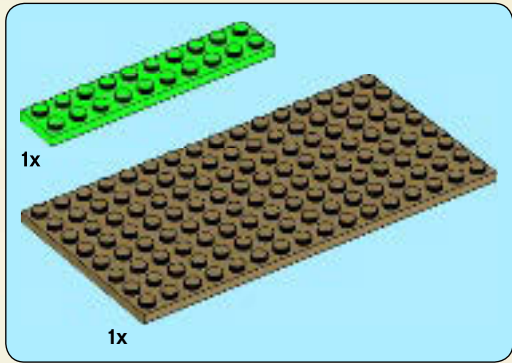
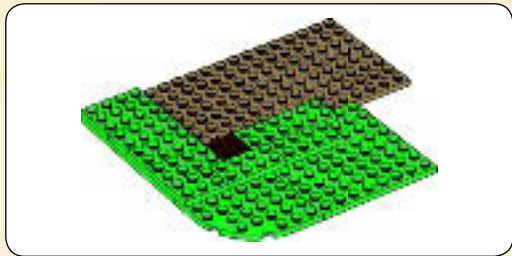

1

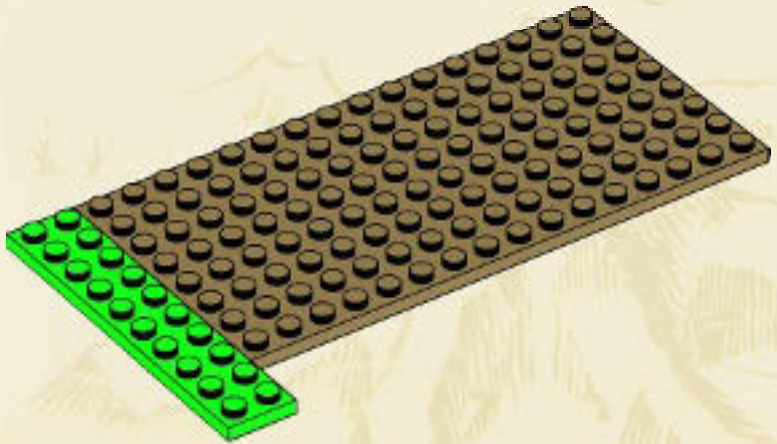

2

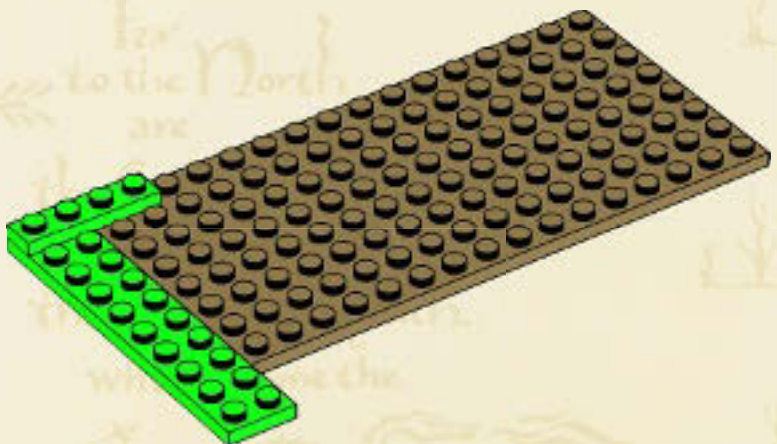



3

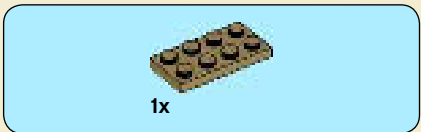
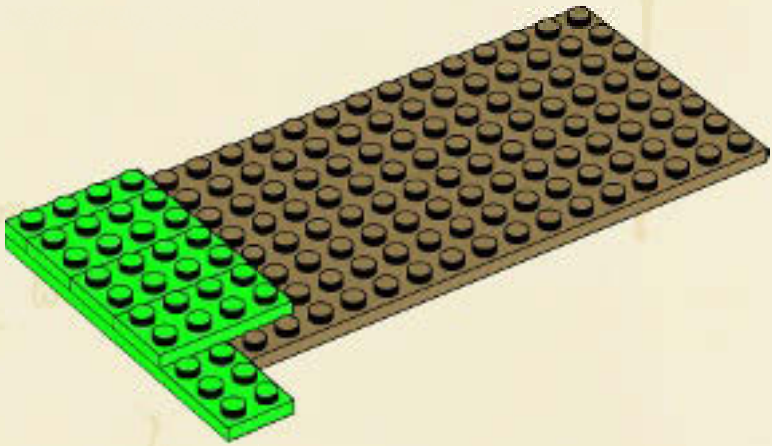

4

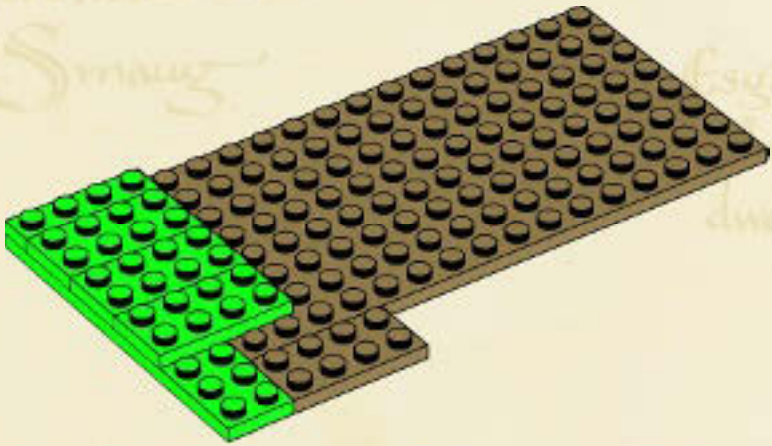



5

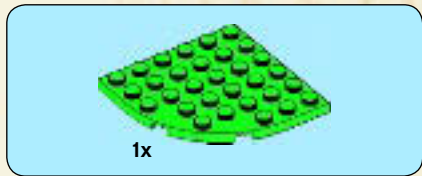
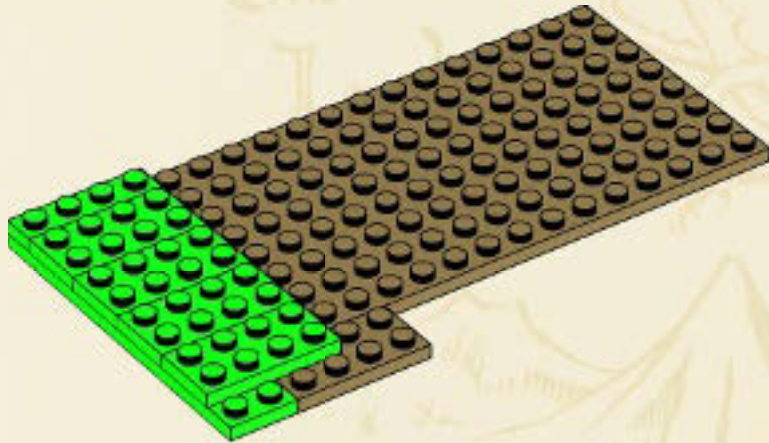

6

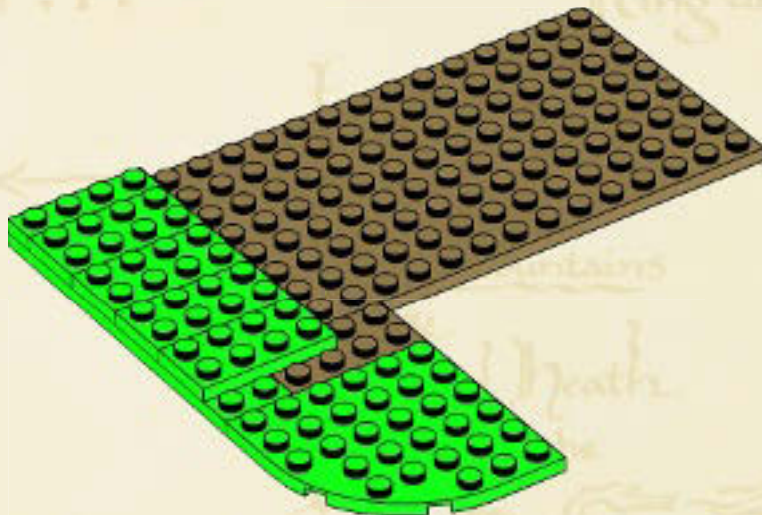



7

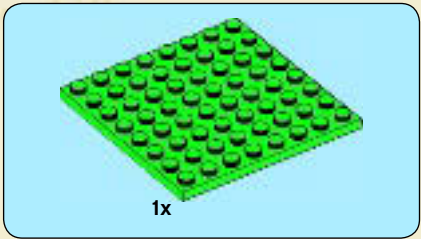
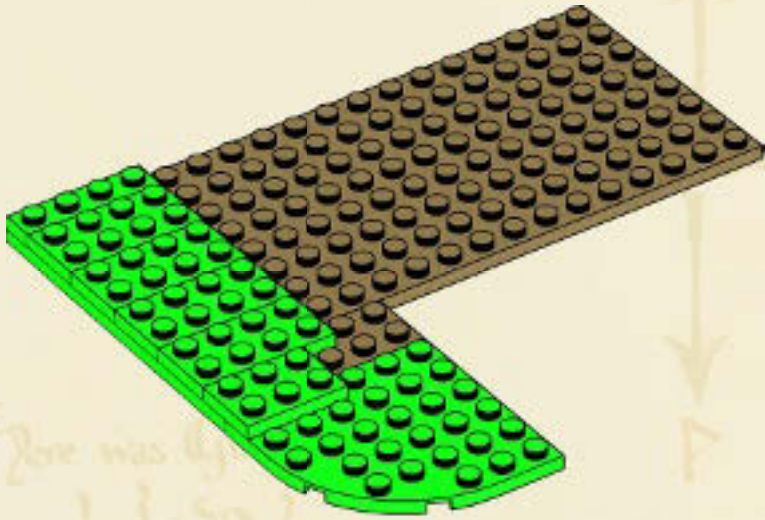

8

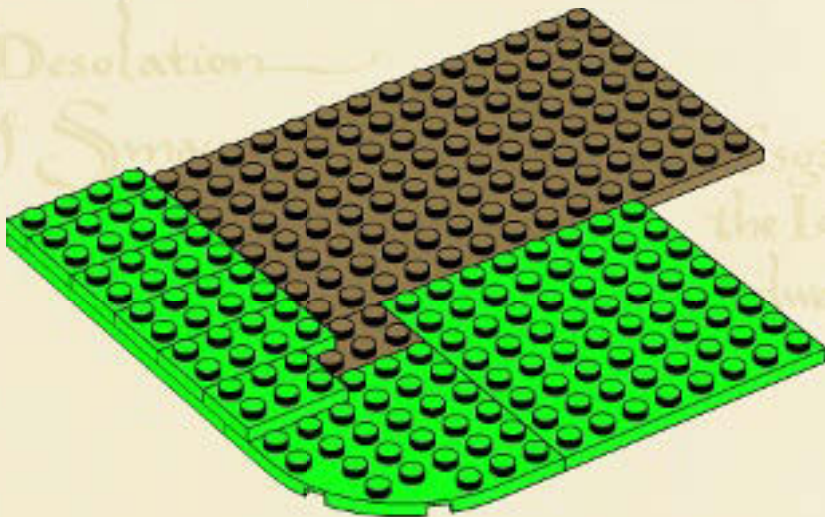



2x

9

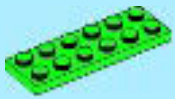
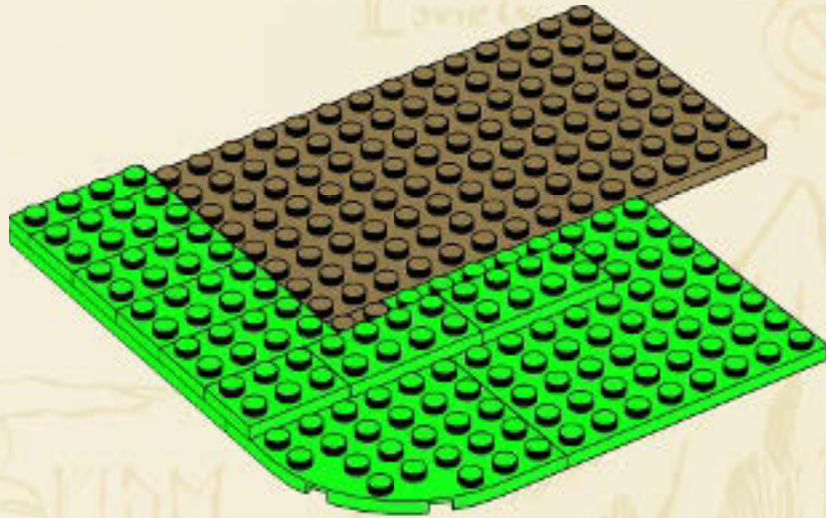

1x



1x

10

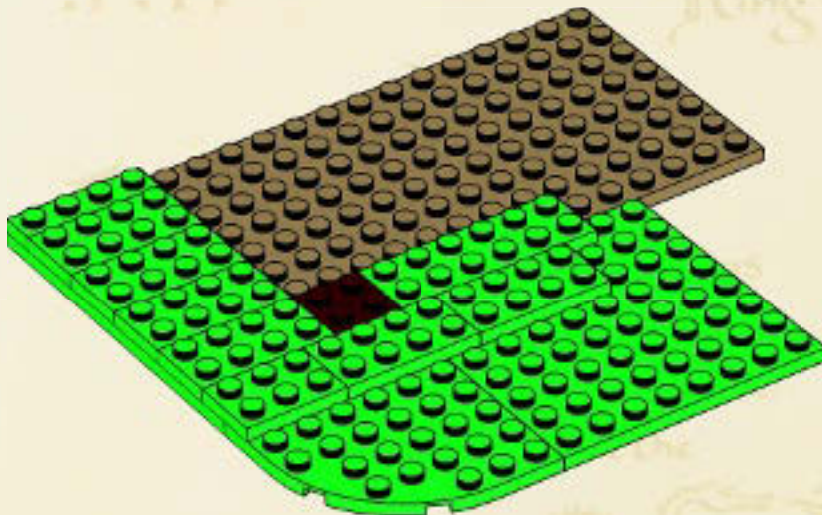

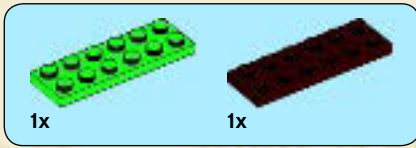

11

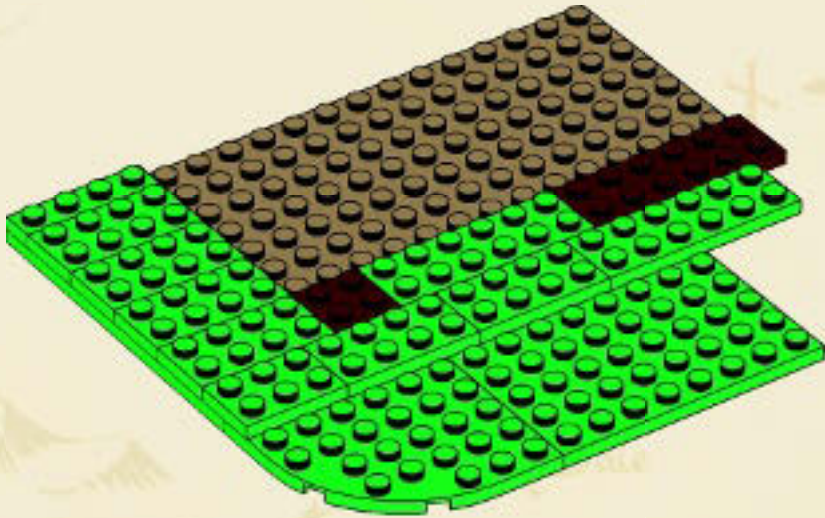

12

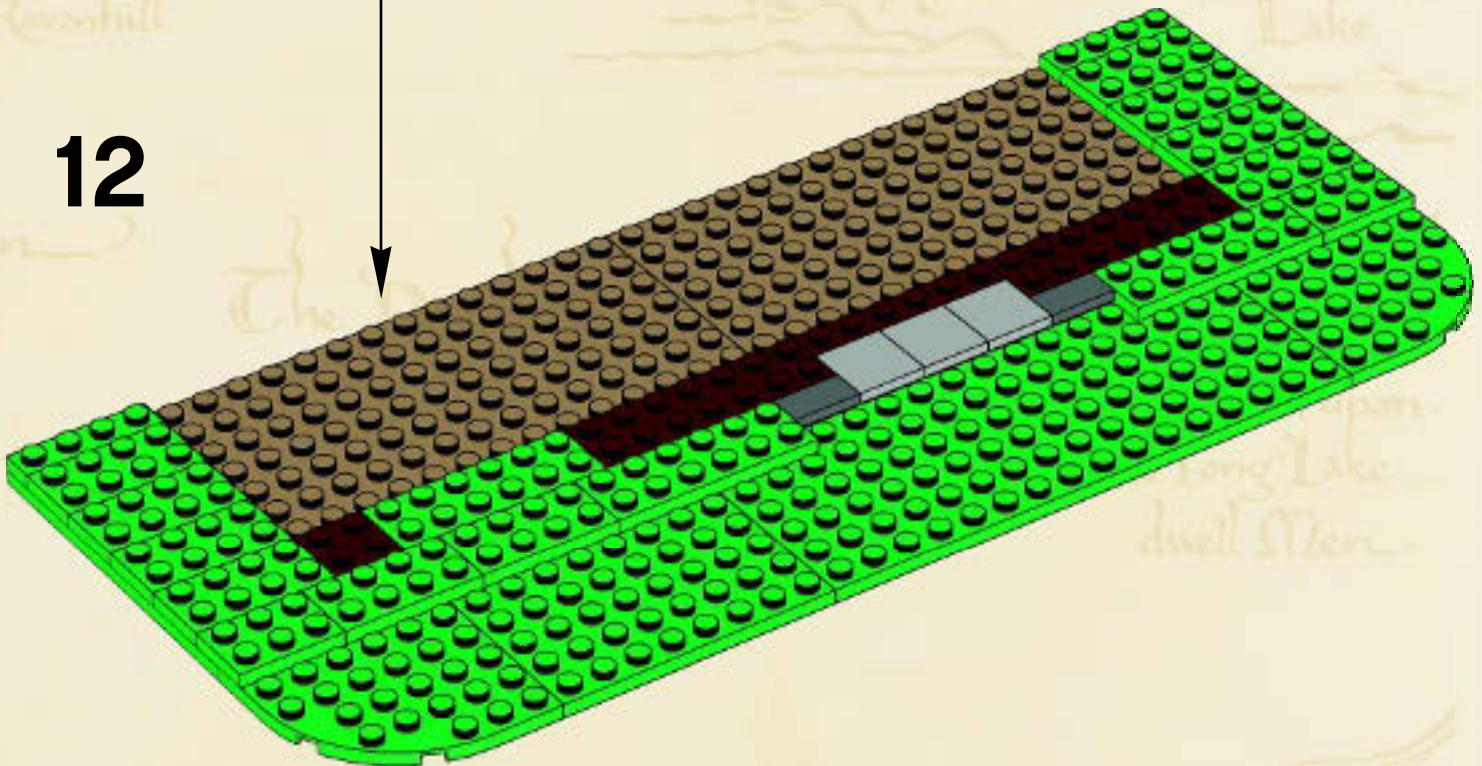



2x

13

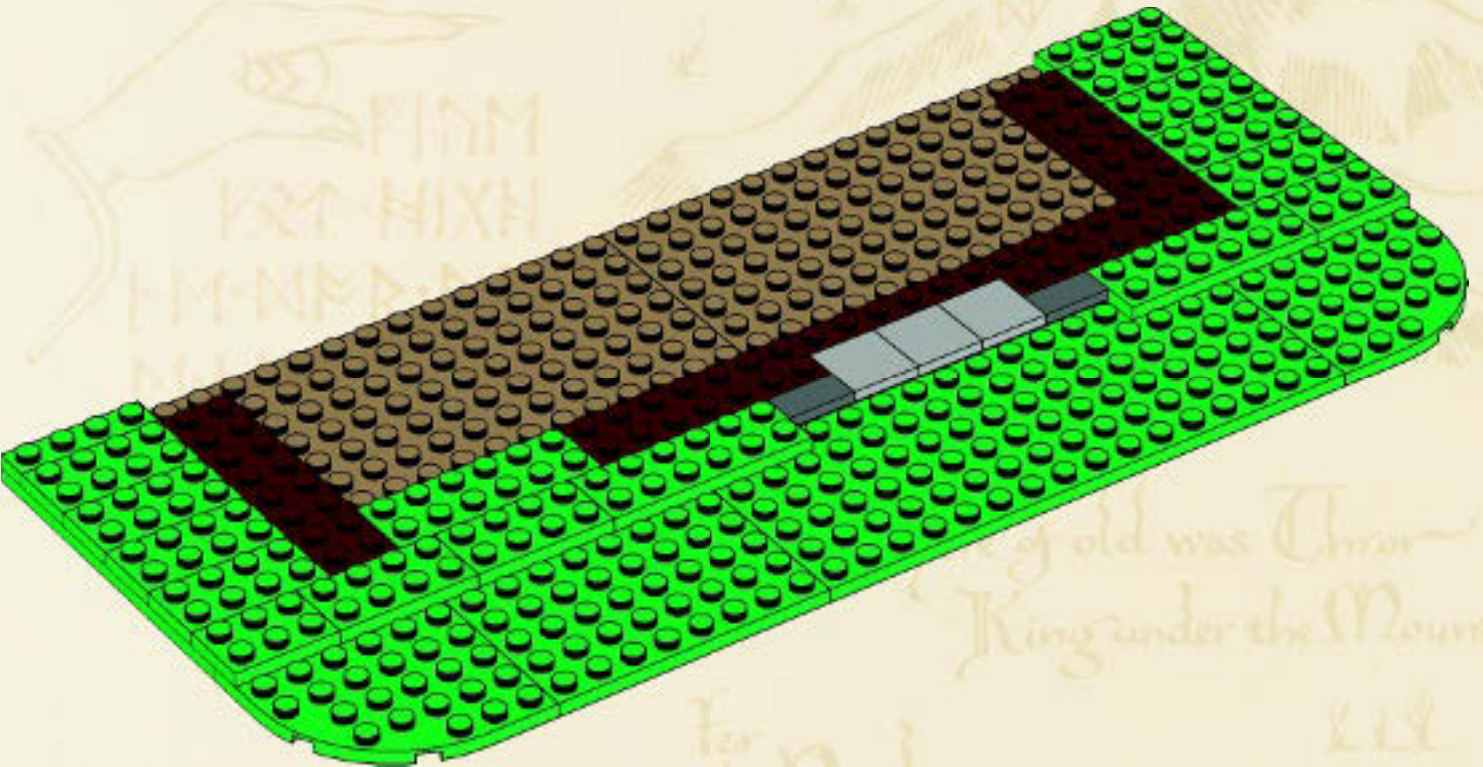

Far
to the North
are
the Grey Mountains
&
the Withered Heath
whence come the

King under the Mountain

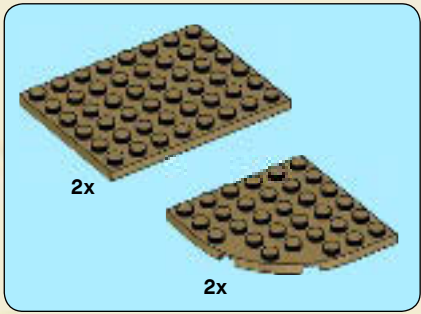

14

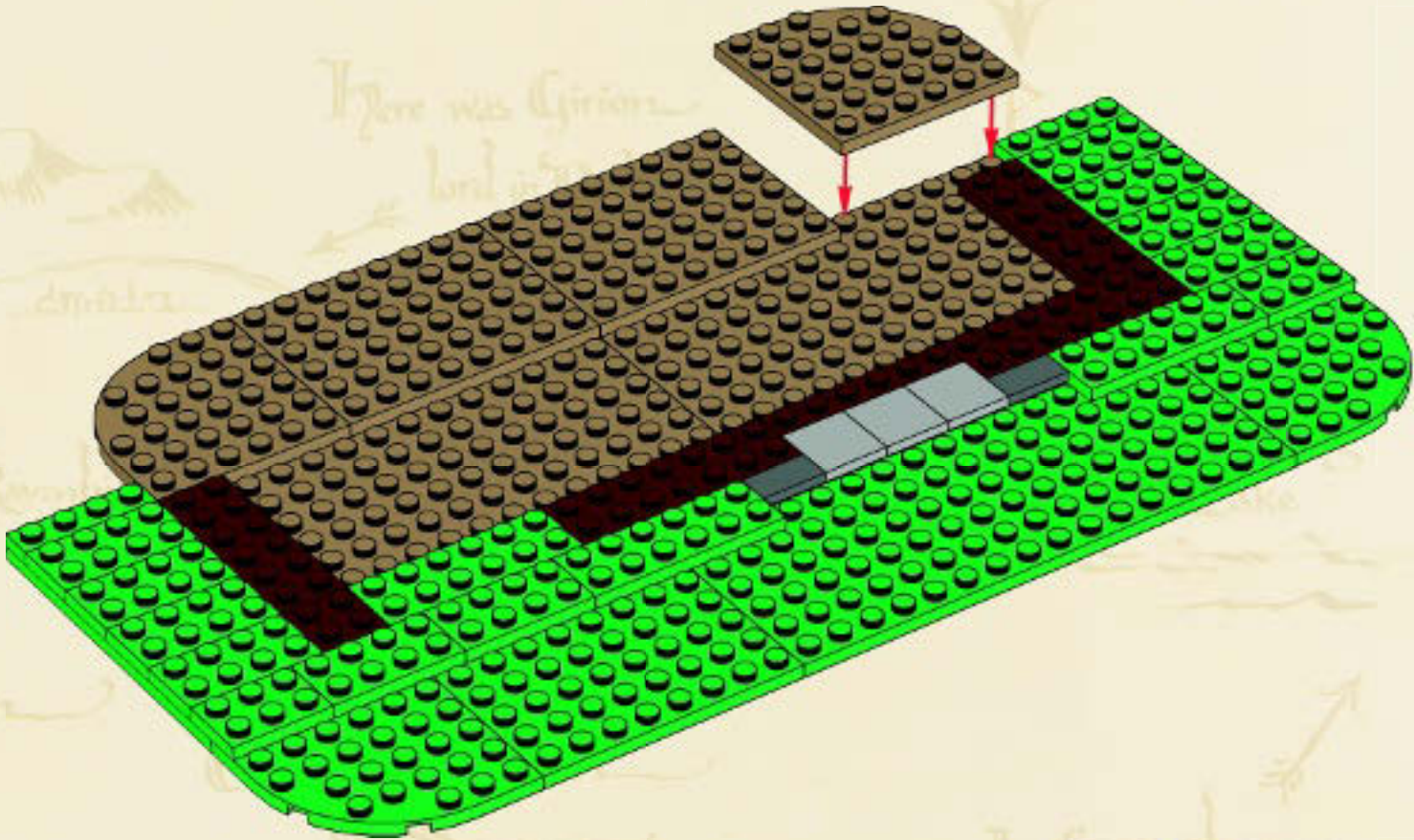



3x

15

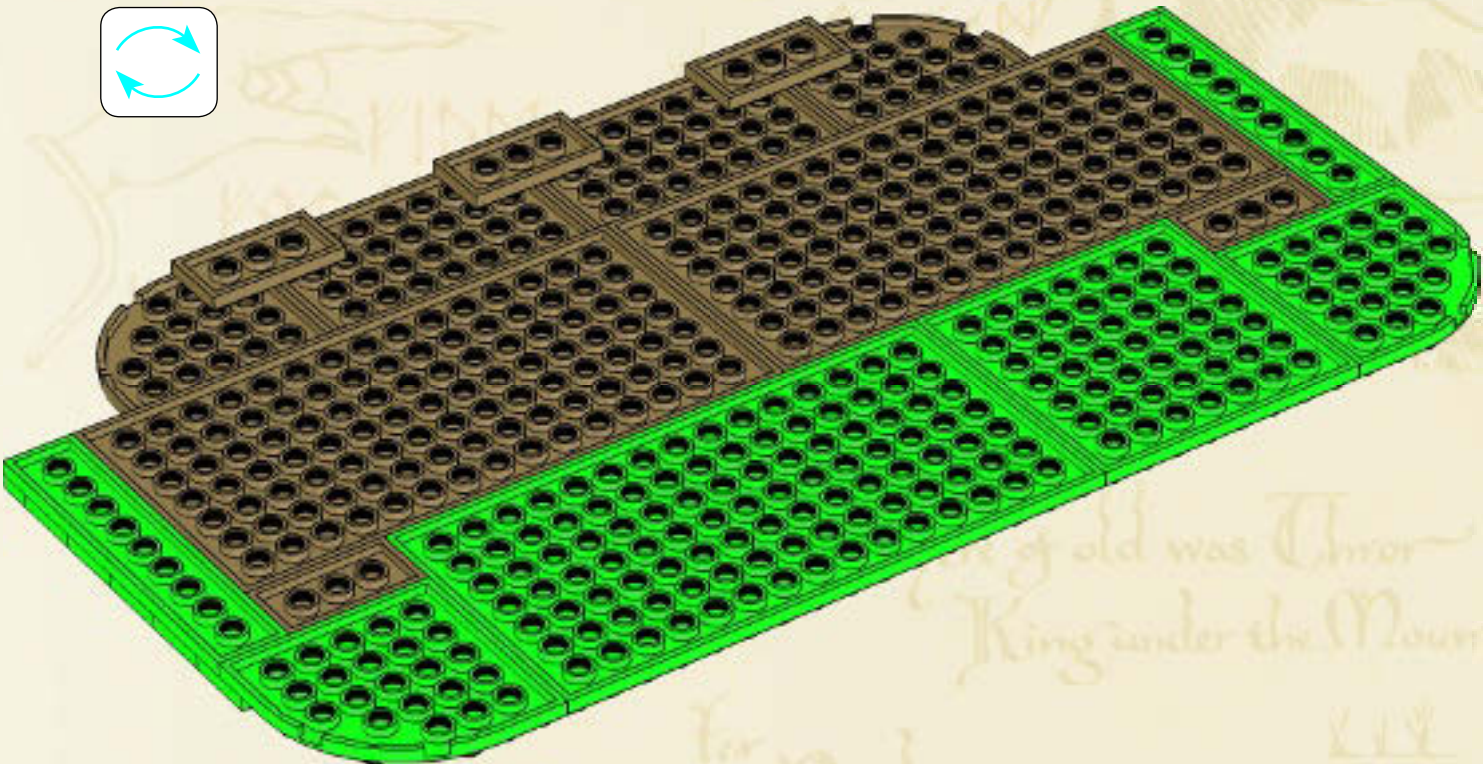
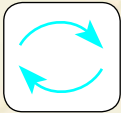

... of old was Thor
King under the Mountain

Far
to the North
are
the Grey Mountains
&
the Withered Heath
whence come the

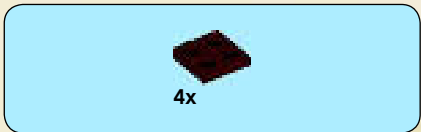

16

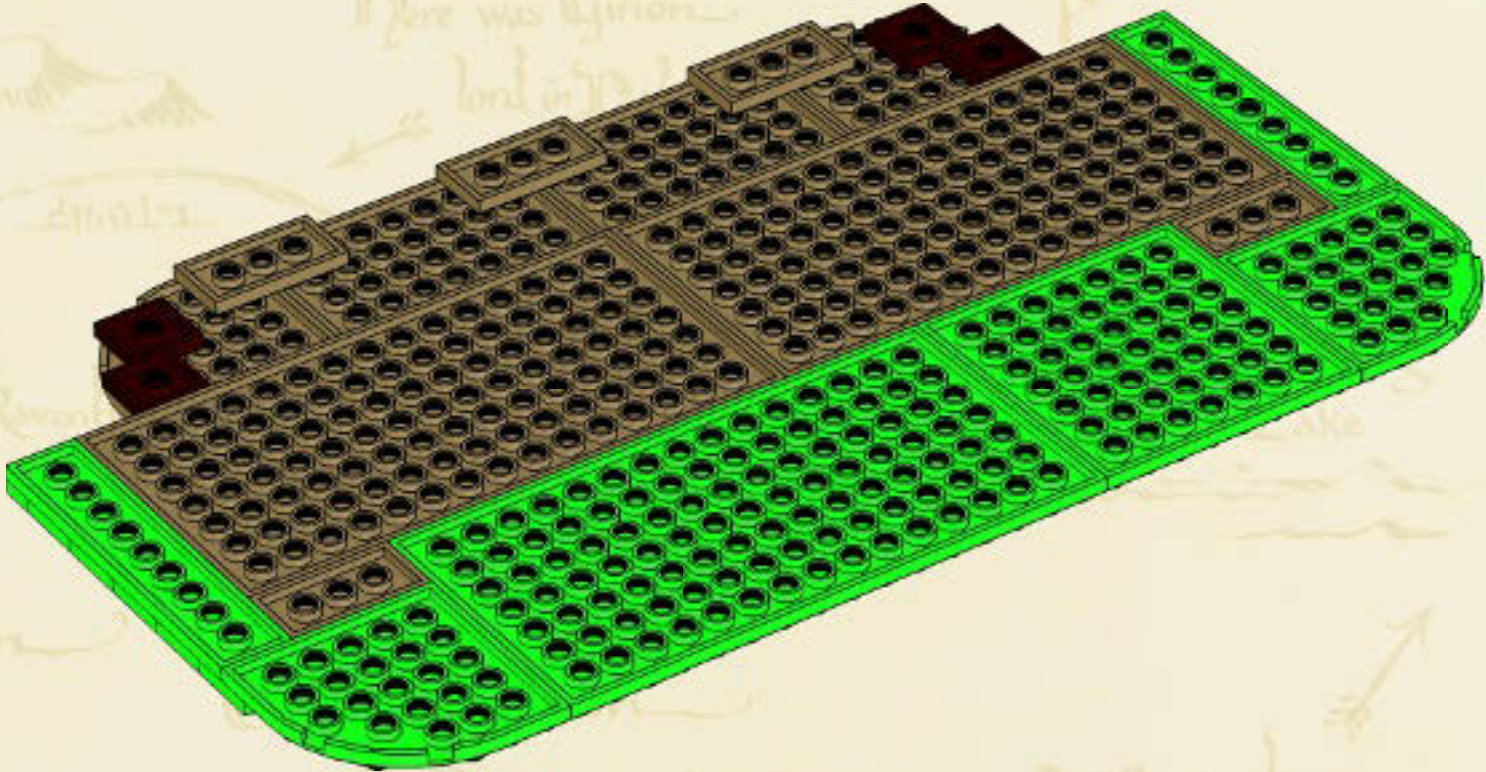

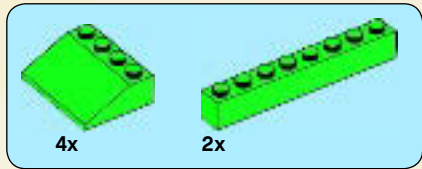

17

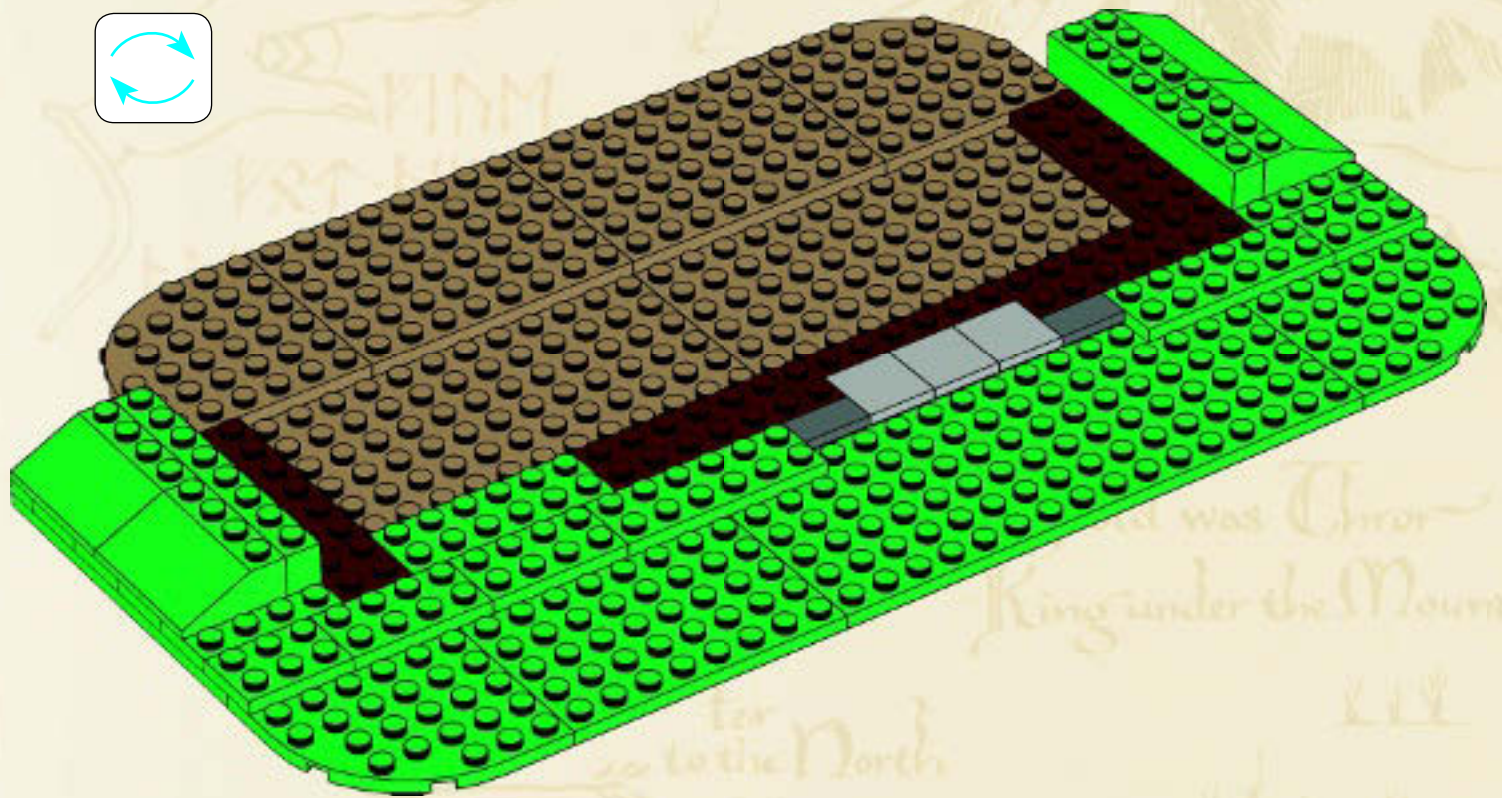
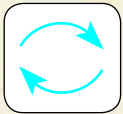



18

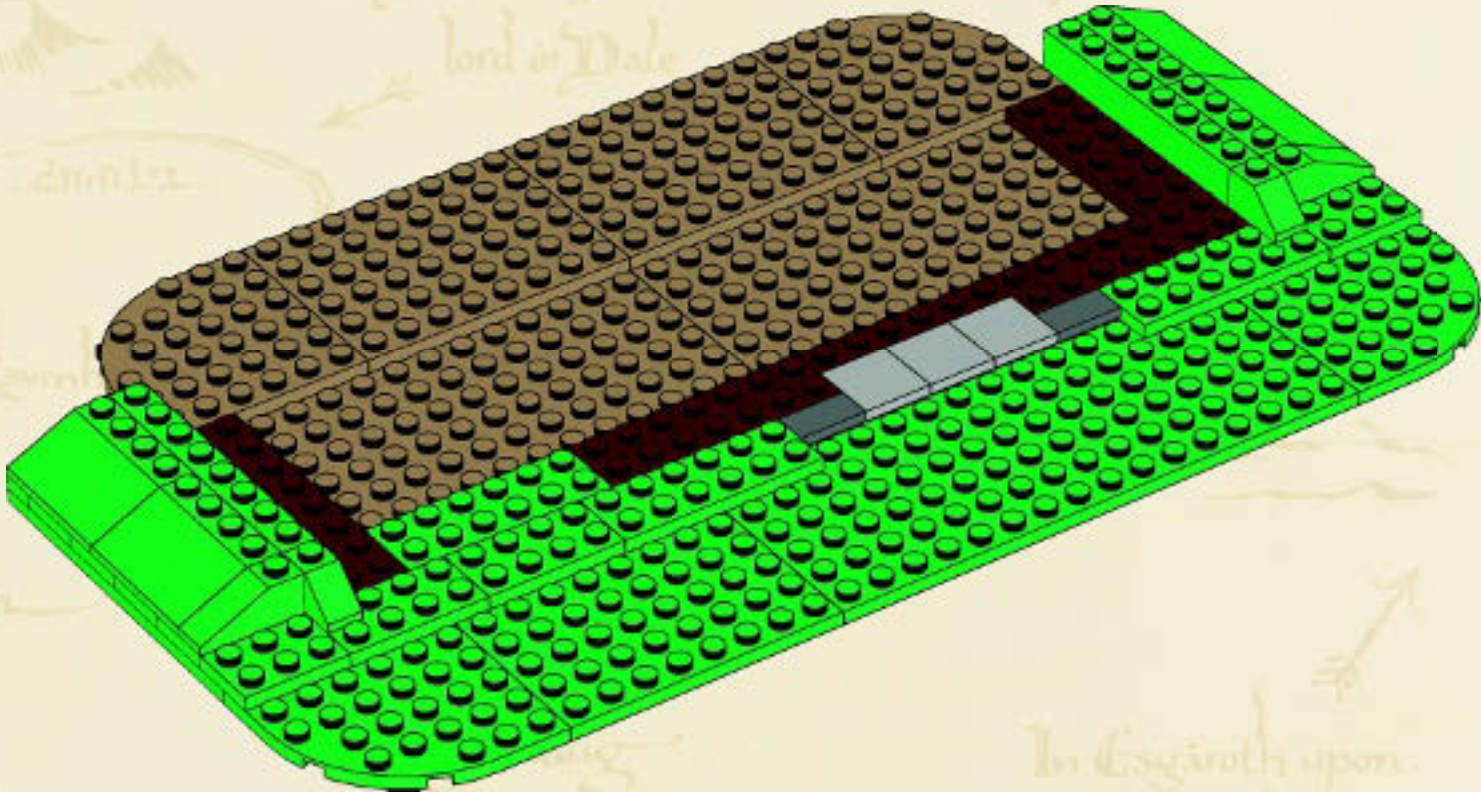

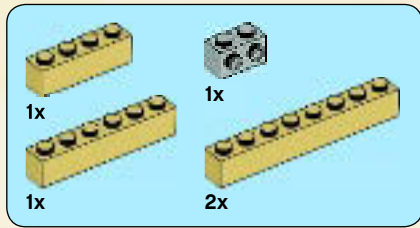

19

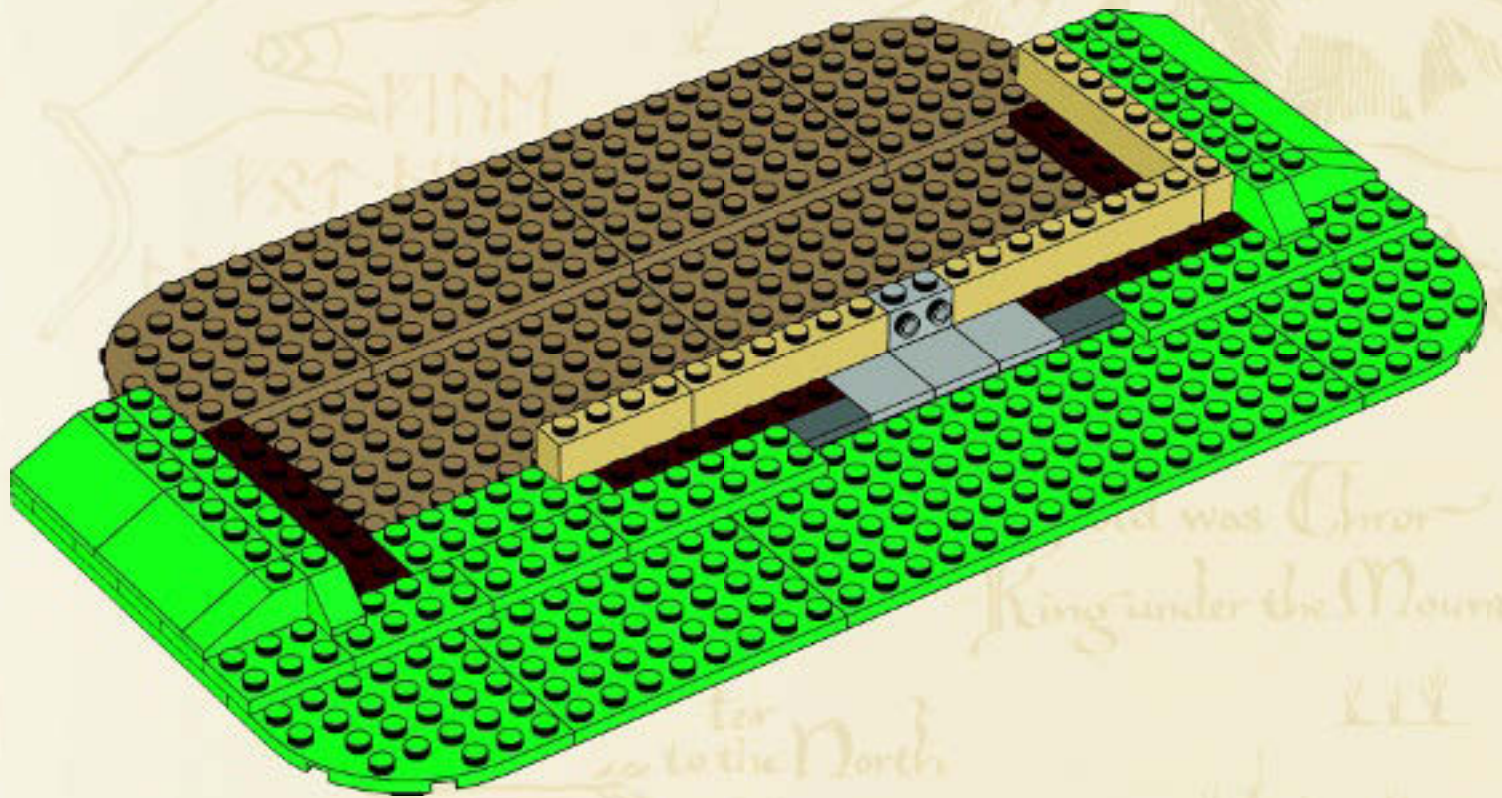

to the North
are
the Grey Mountains

the Withered Heath
whence come the

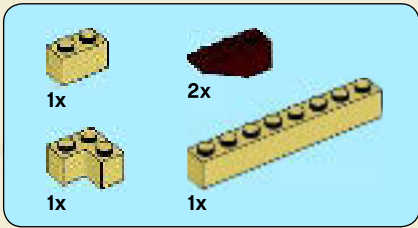

20

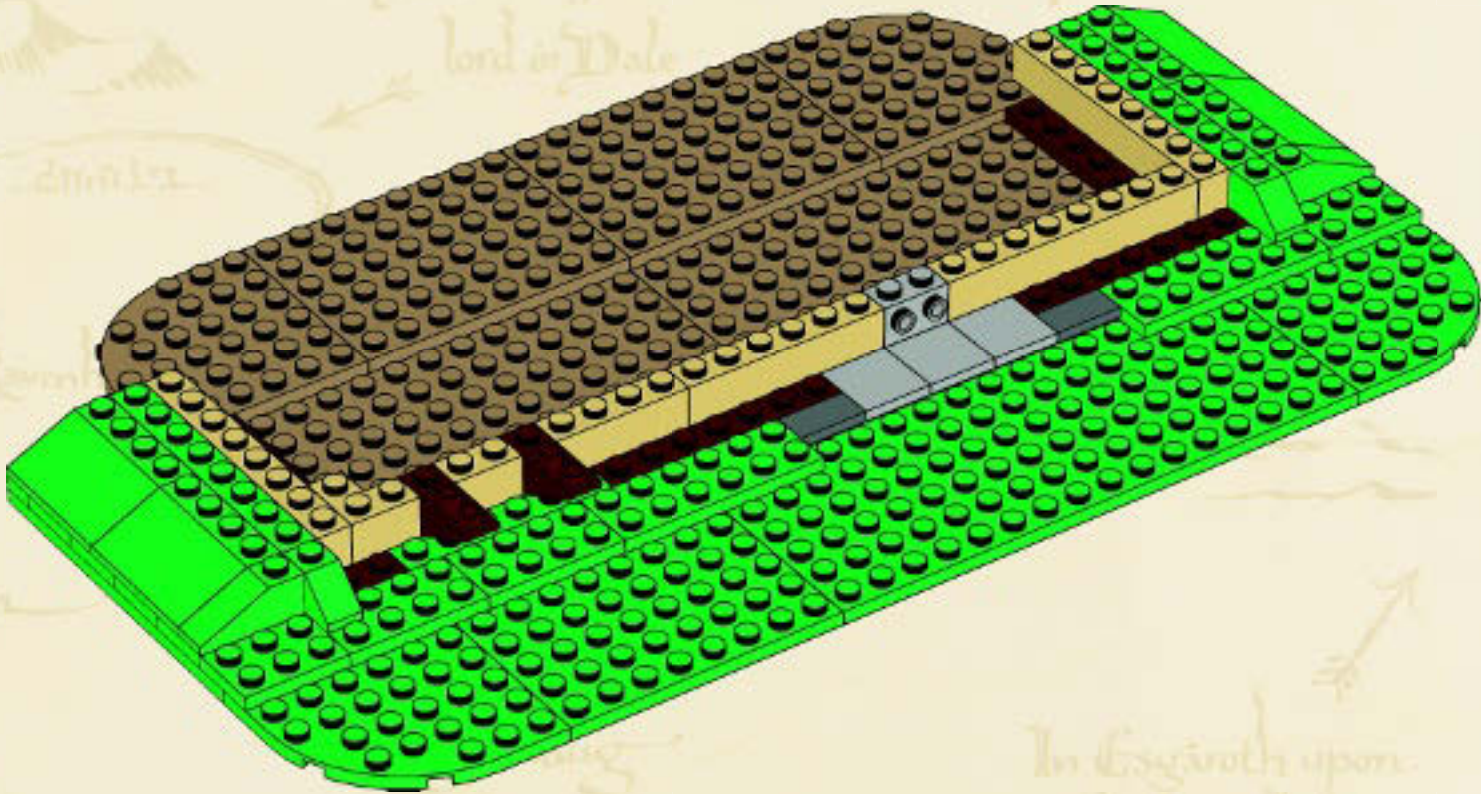

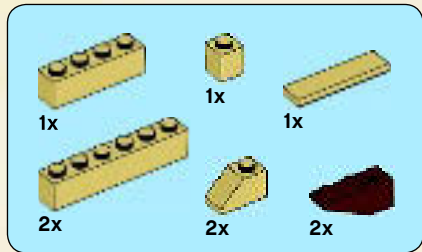

21

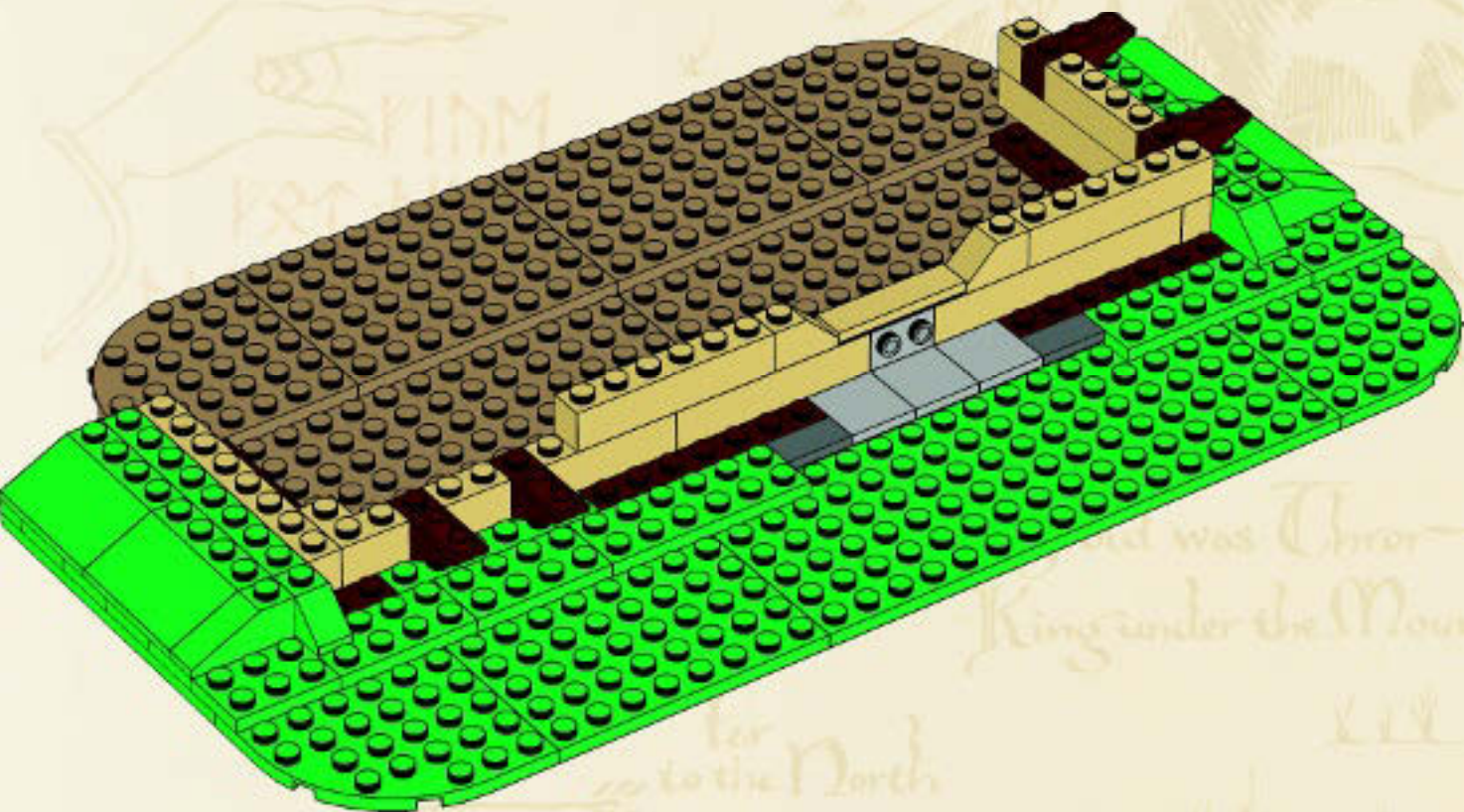

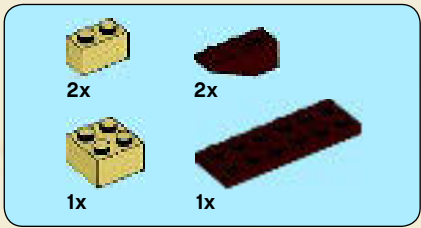

22

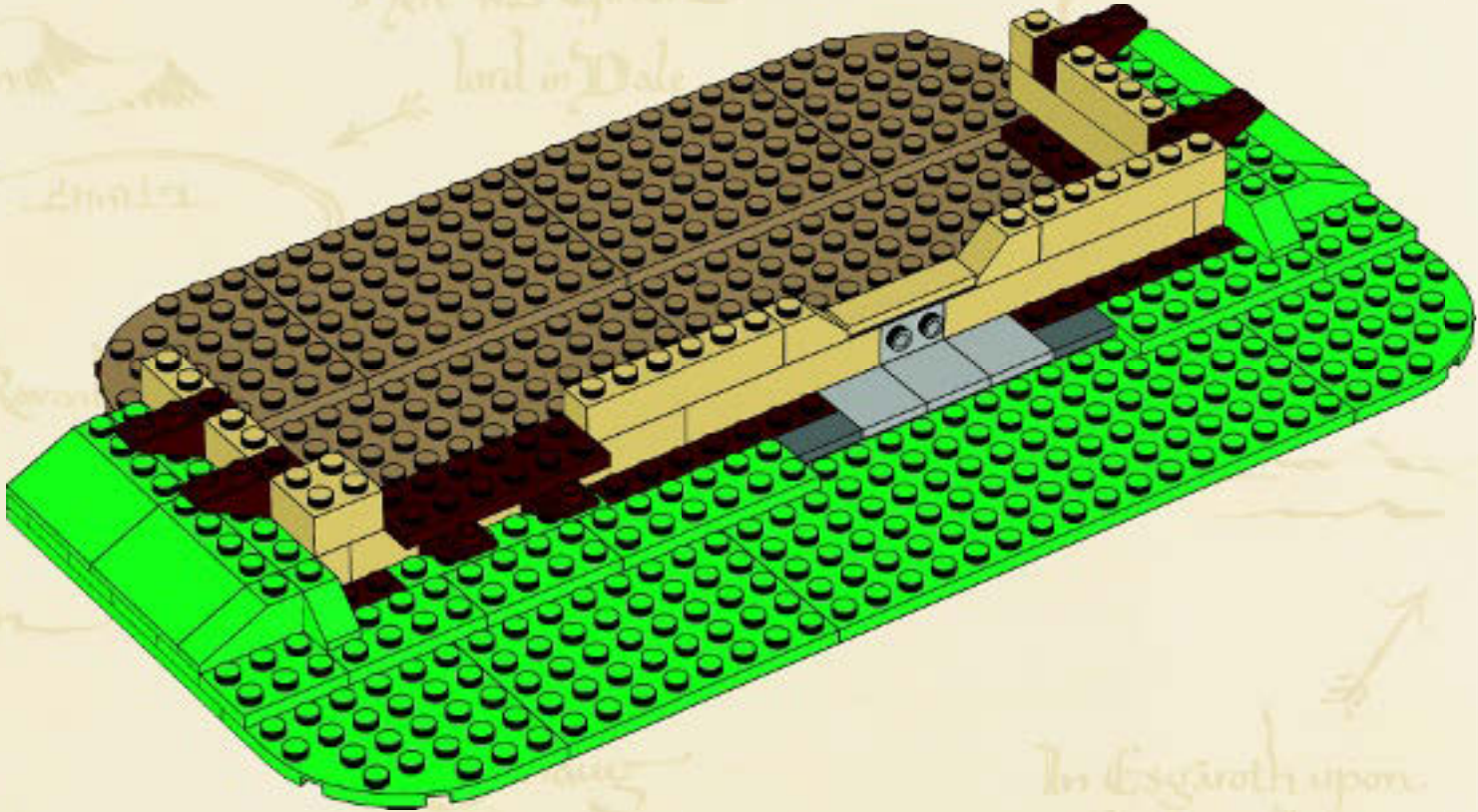

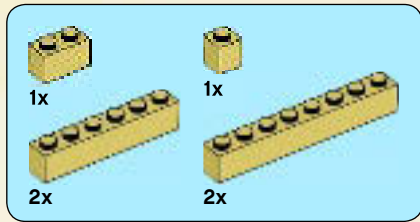

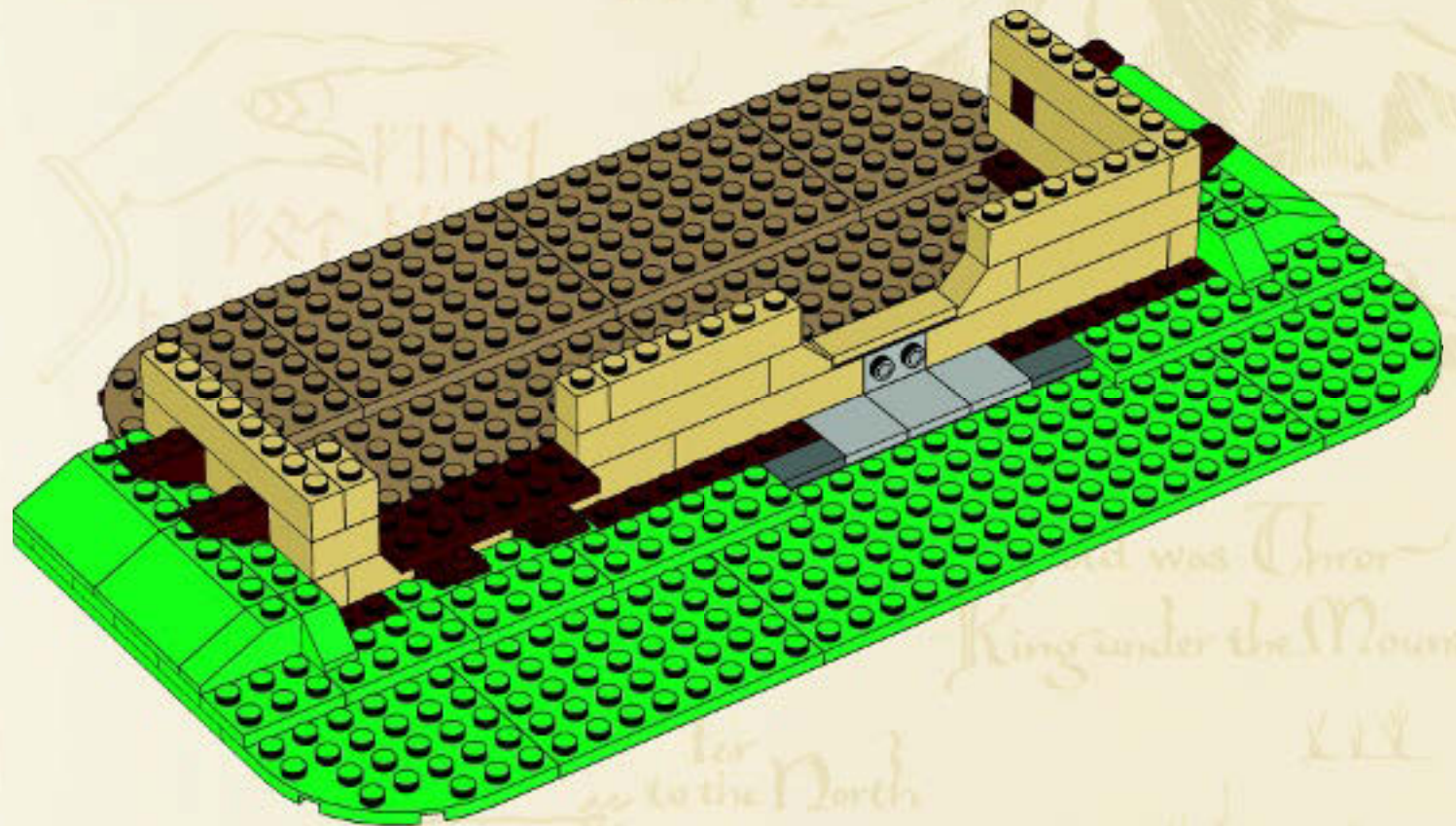

23

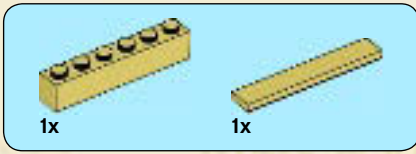

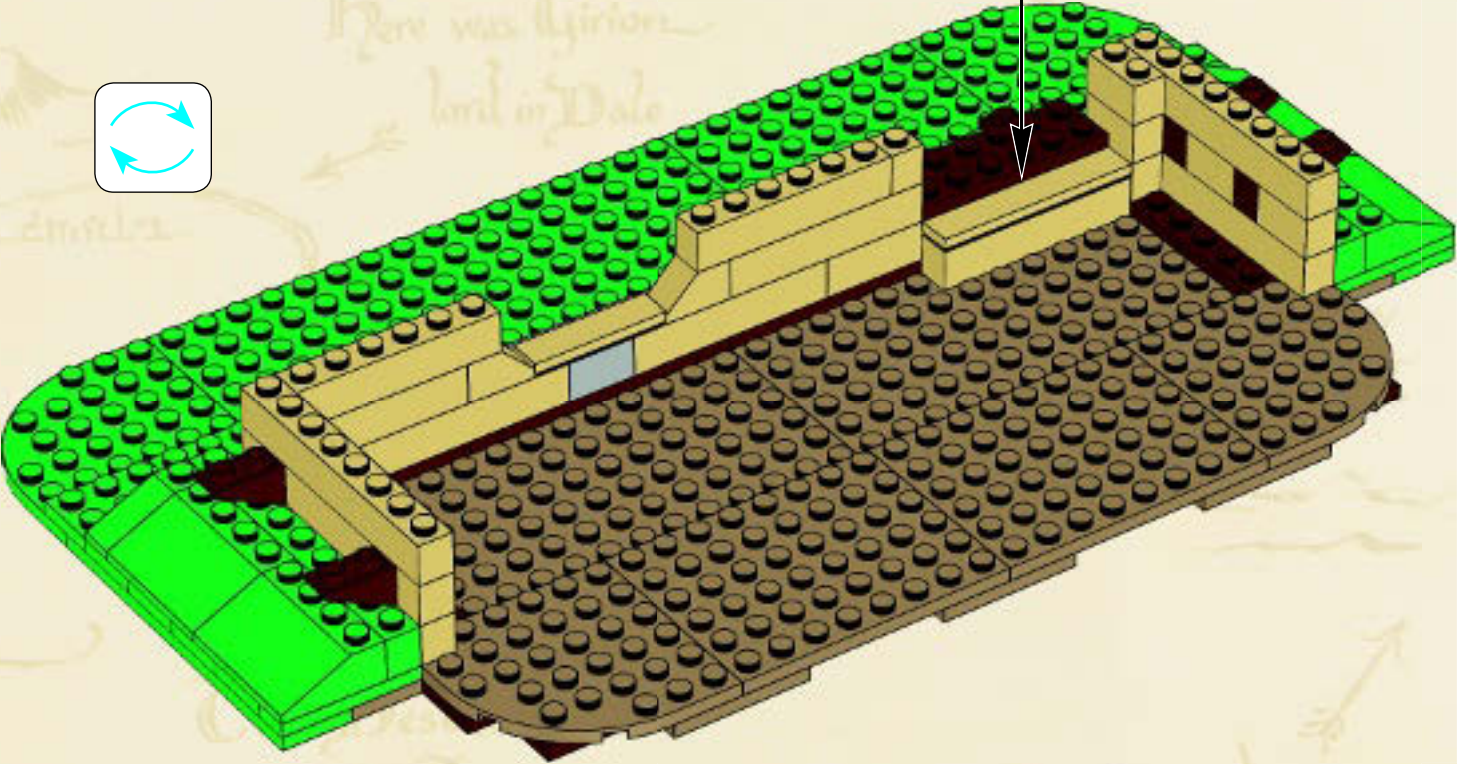
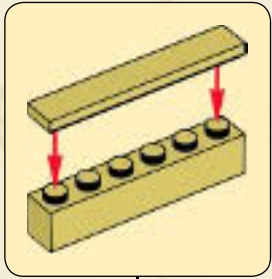

24



2x  1x 

25

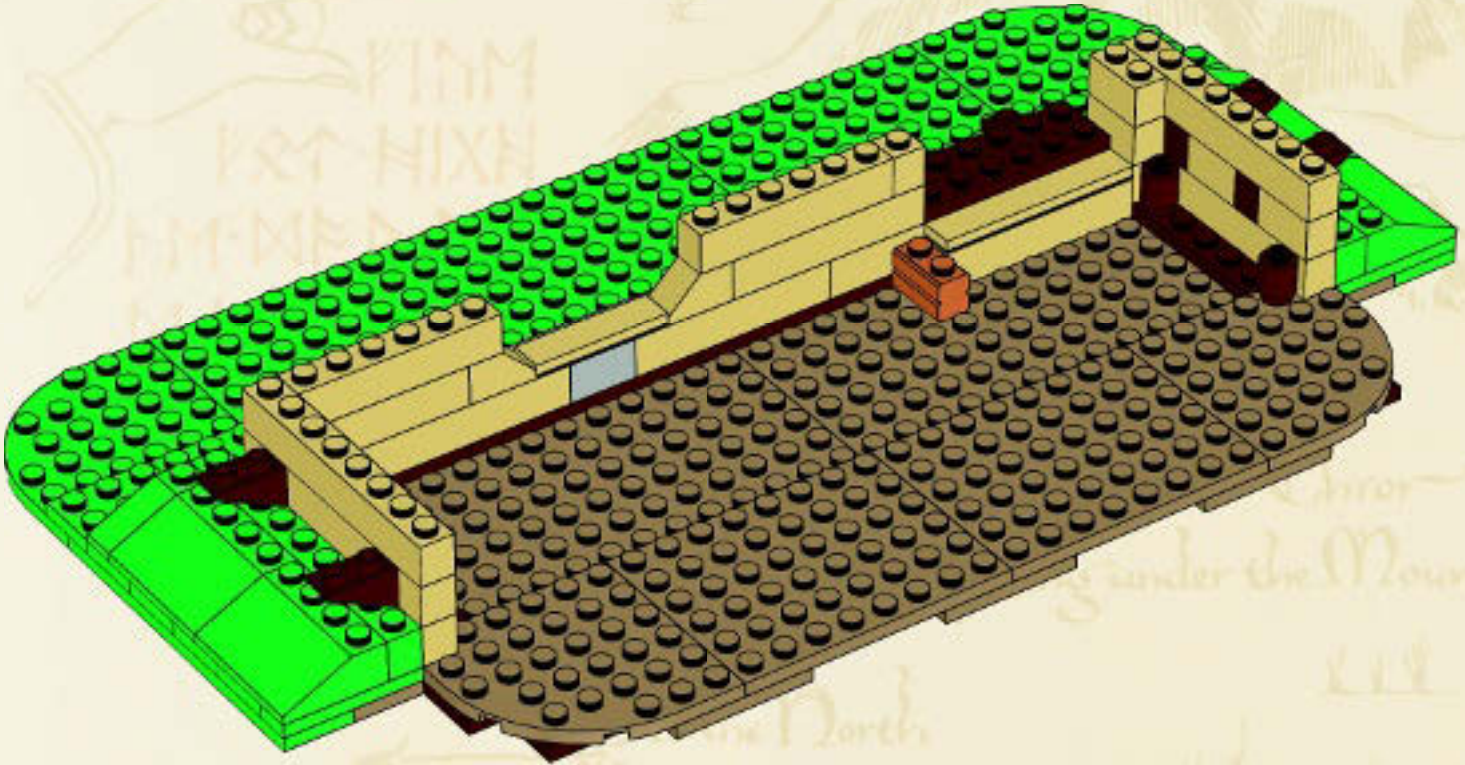



26

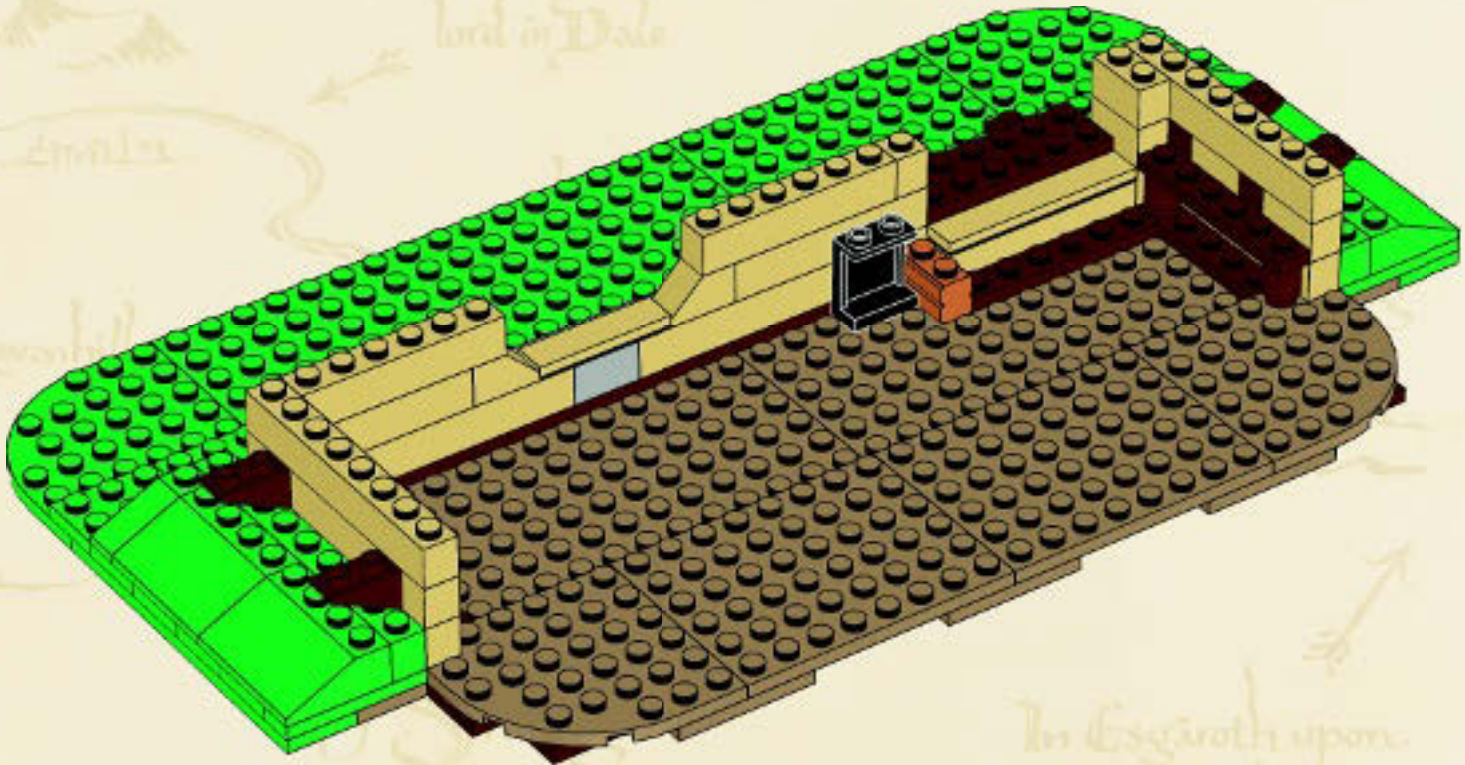

			
2x	1x	2x	1x

27

1	
2	

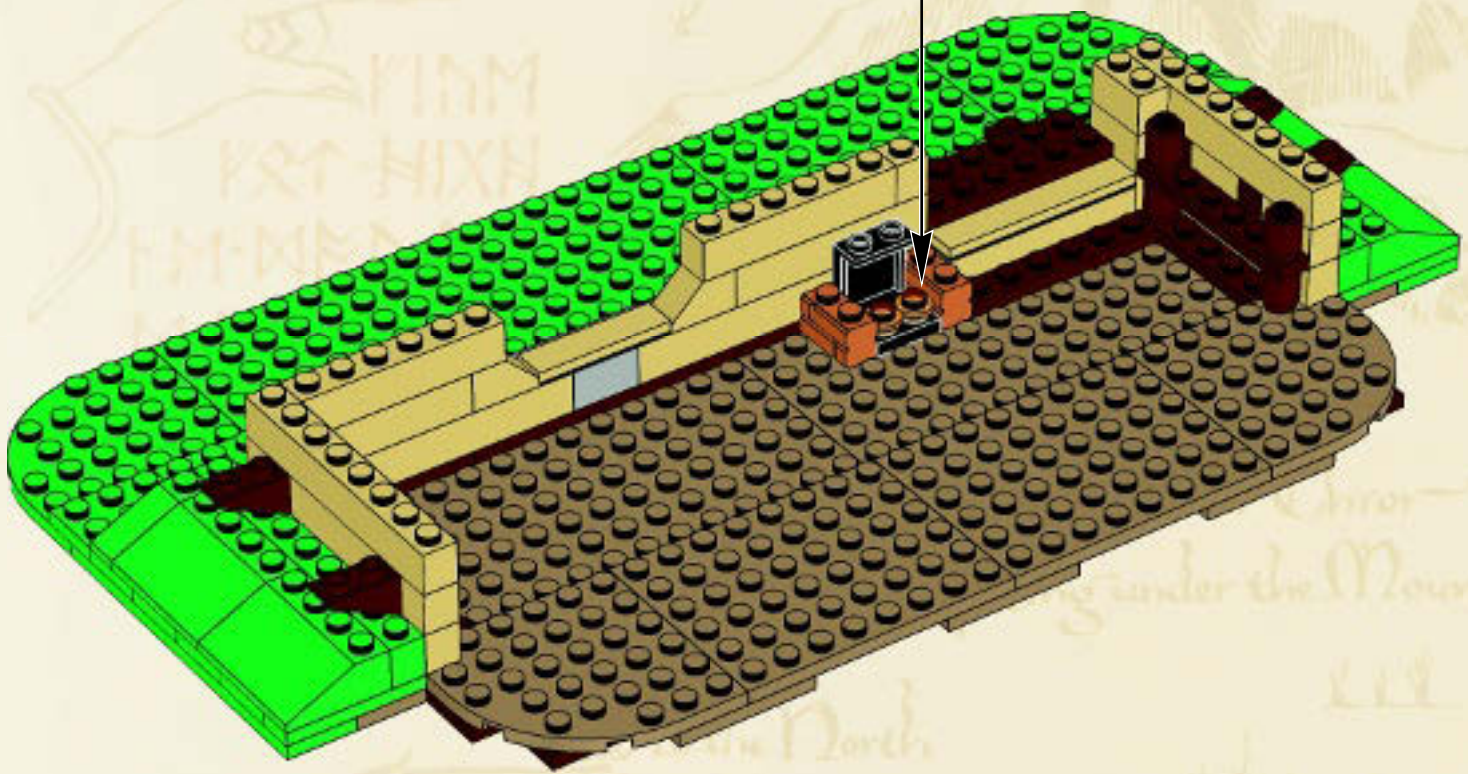



28

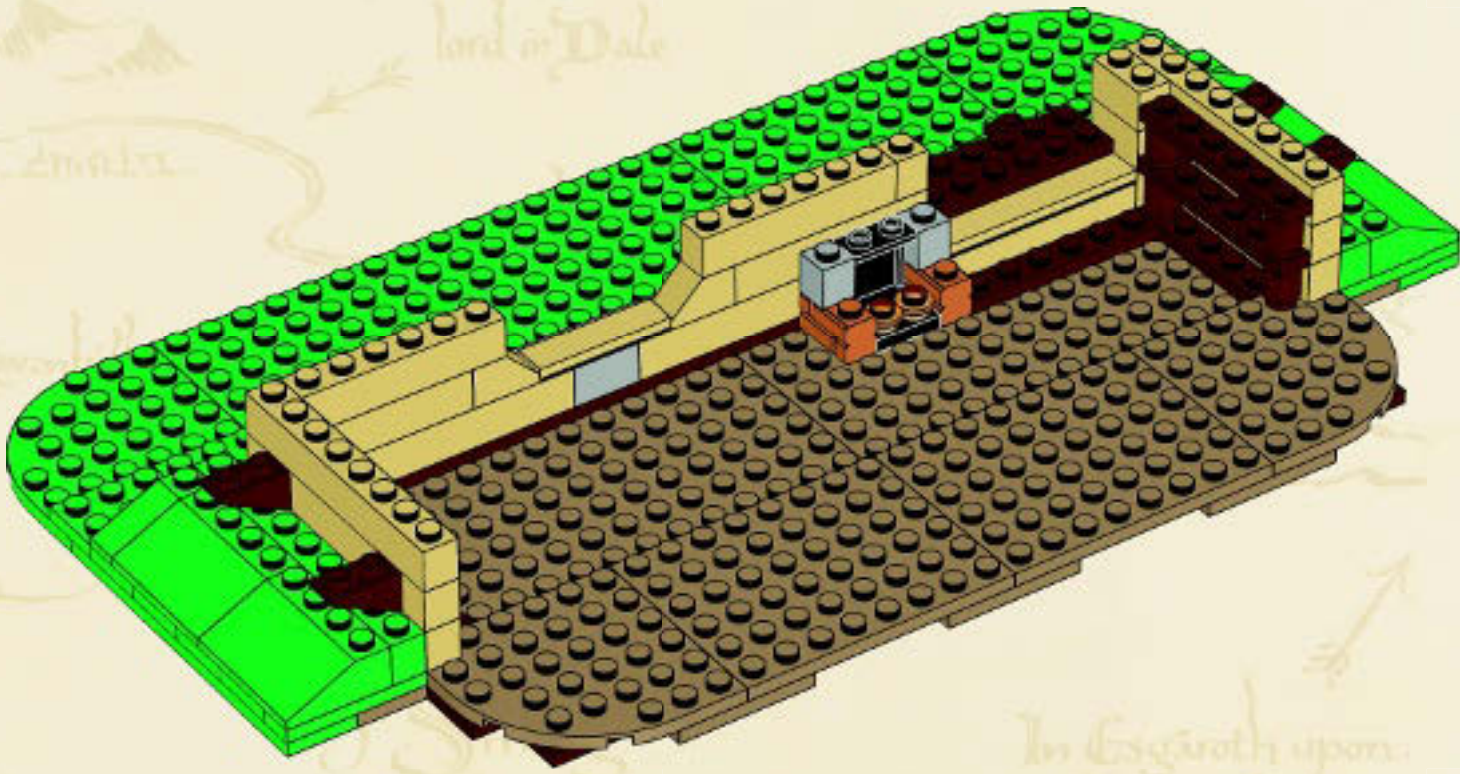

*Here was Gyrfinn
lord of Dale*

*In Esgaroth upon
the Long Lake
dwell Men*

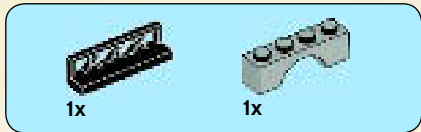

29

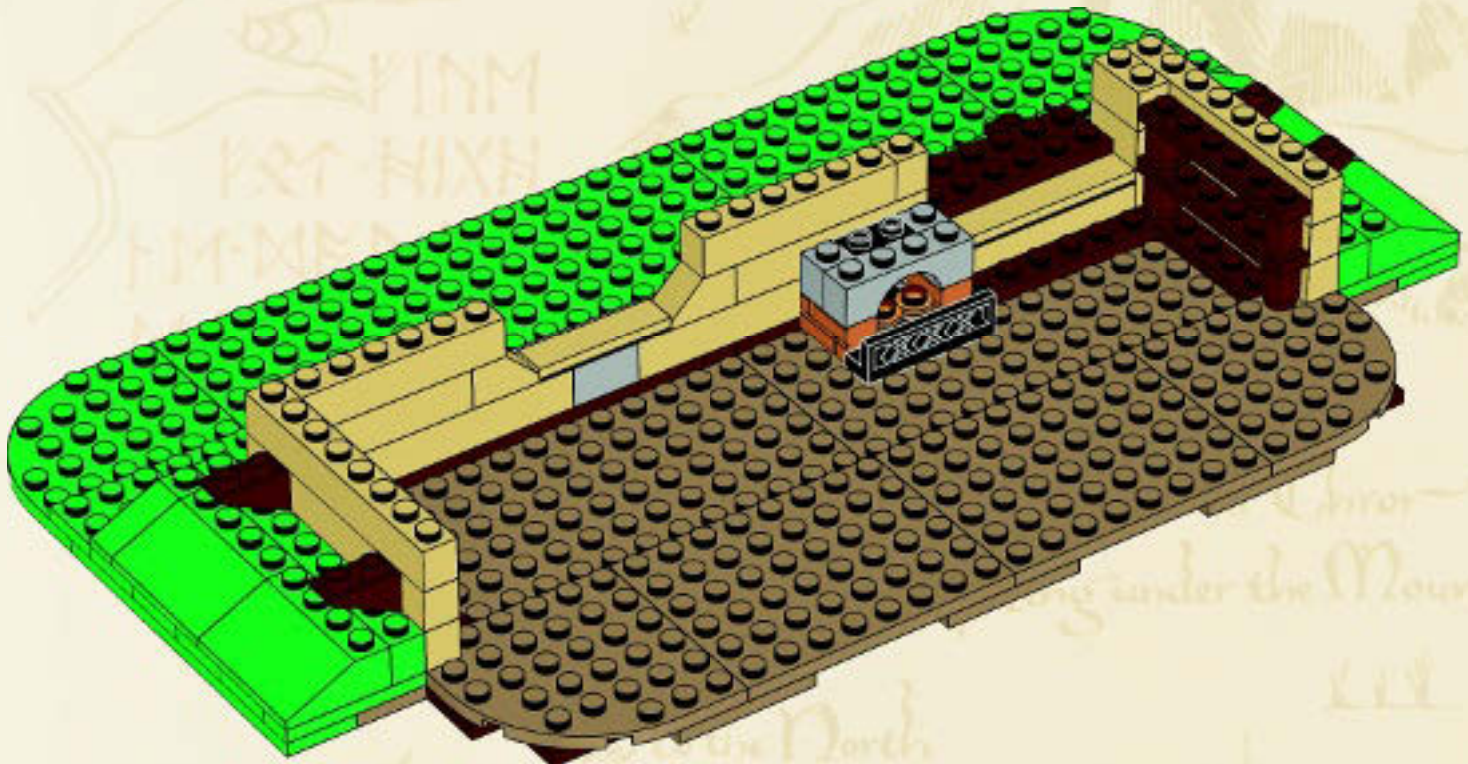

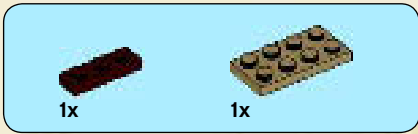

30

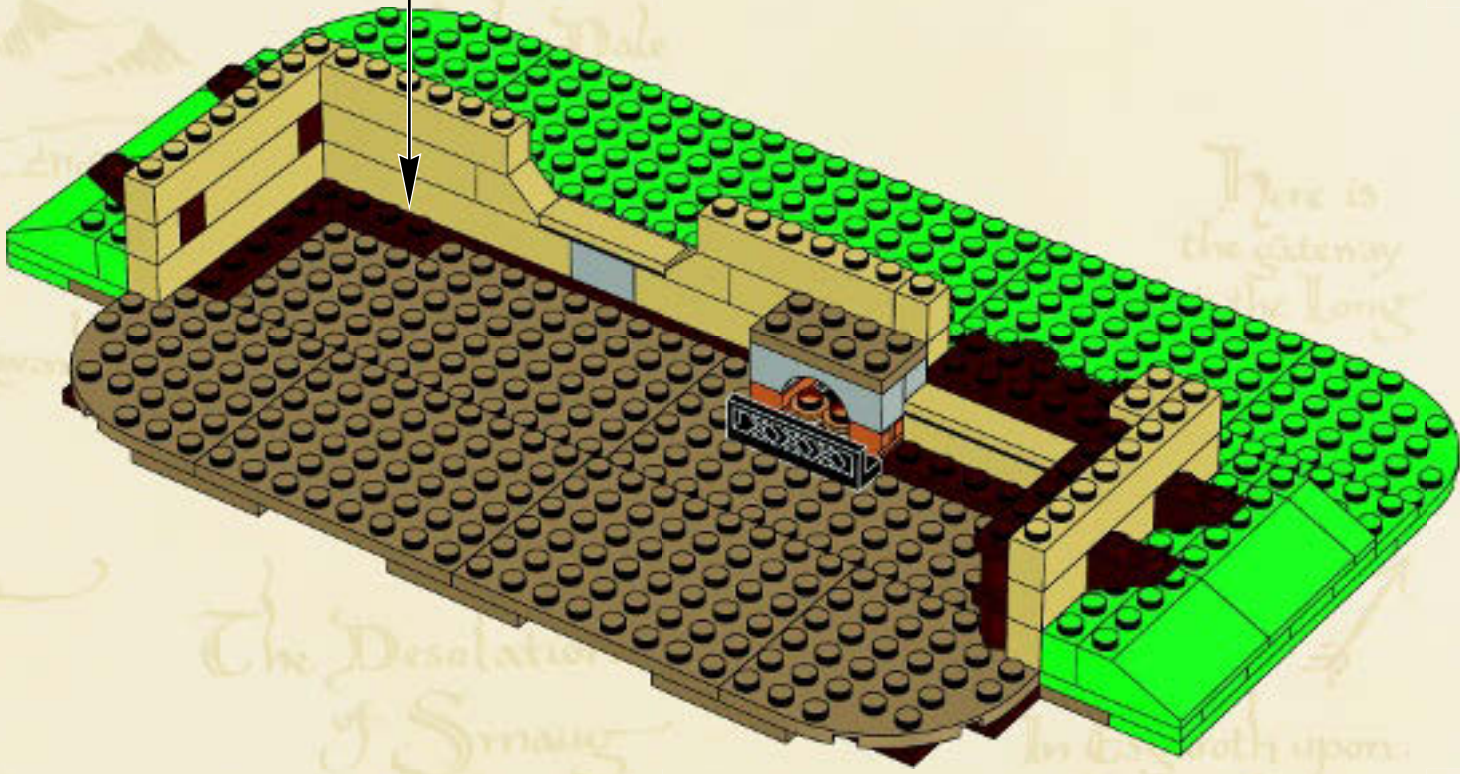
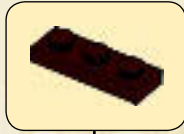
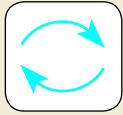

2x 1x

31

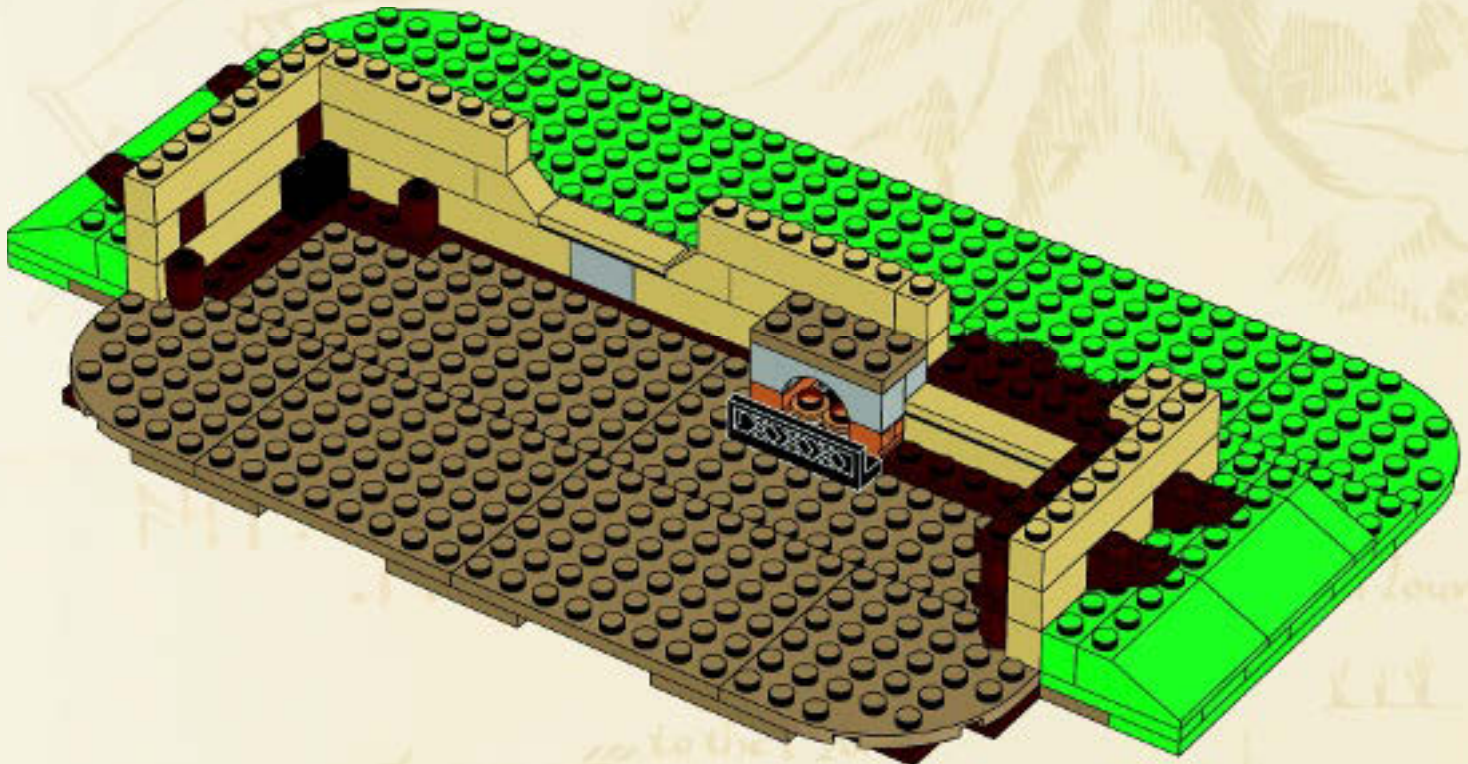

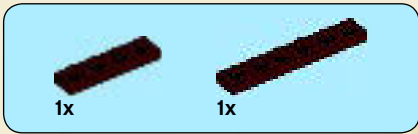

32

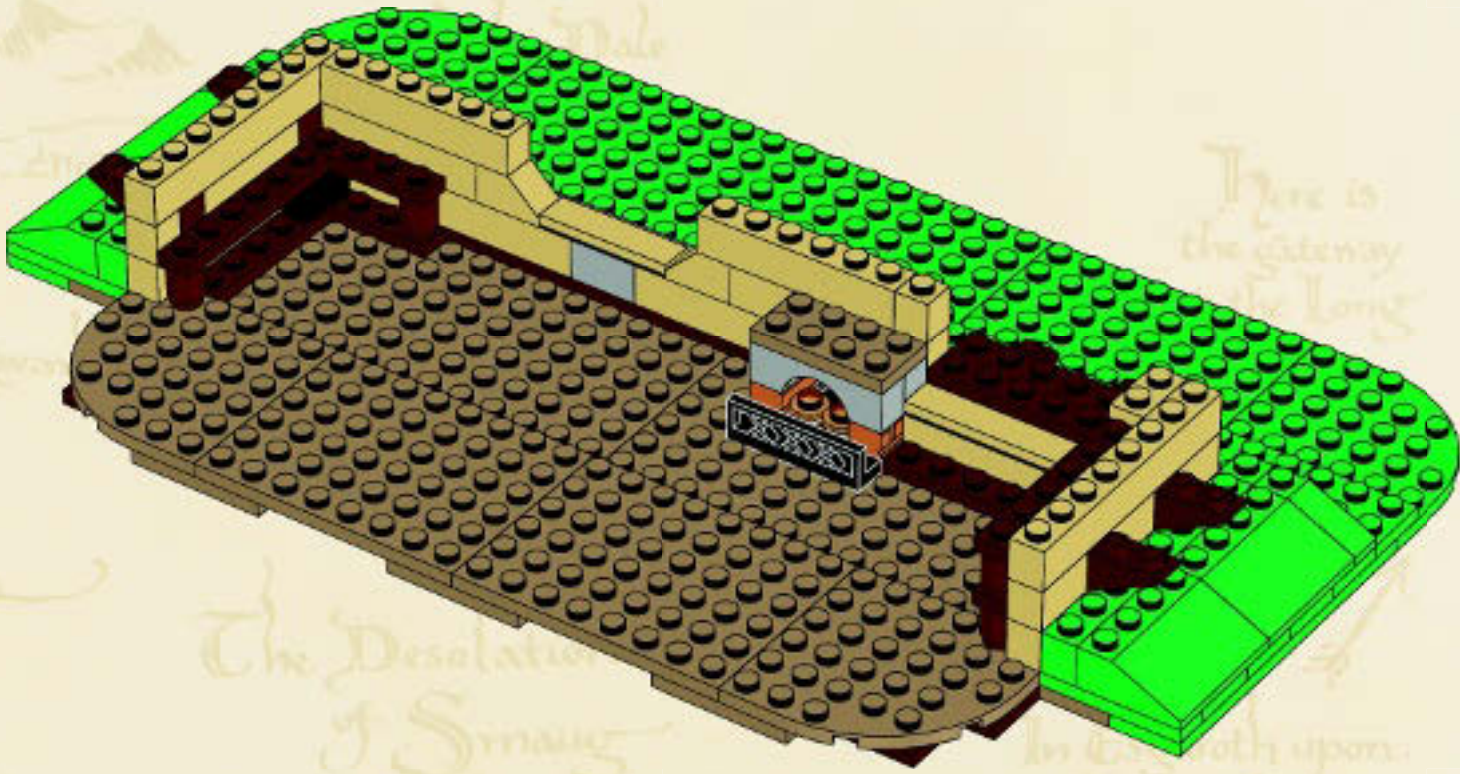



2x



1x

33

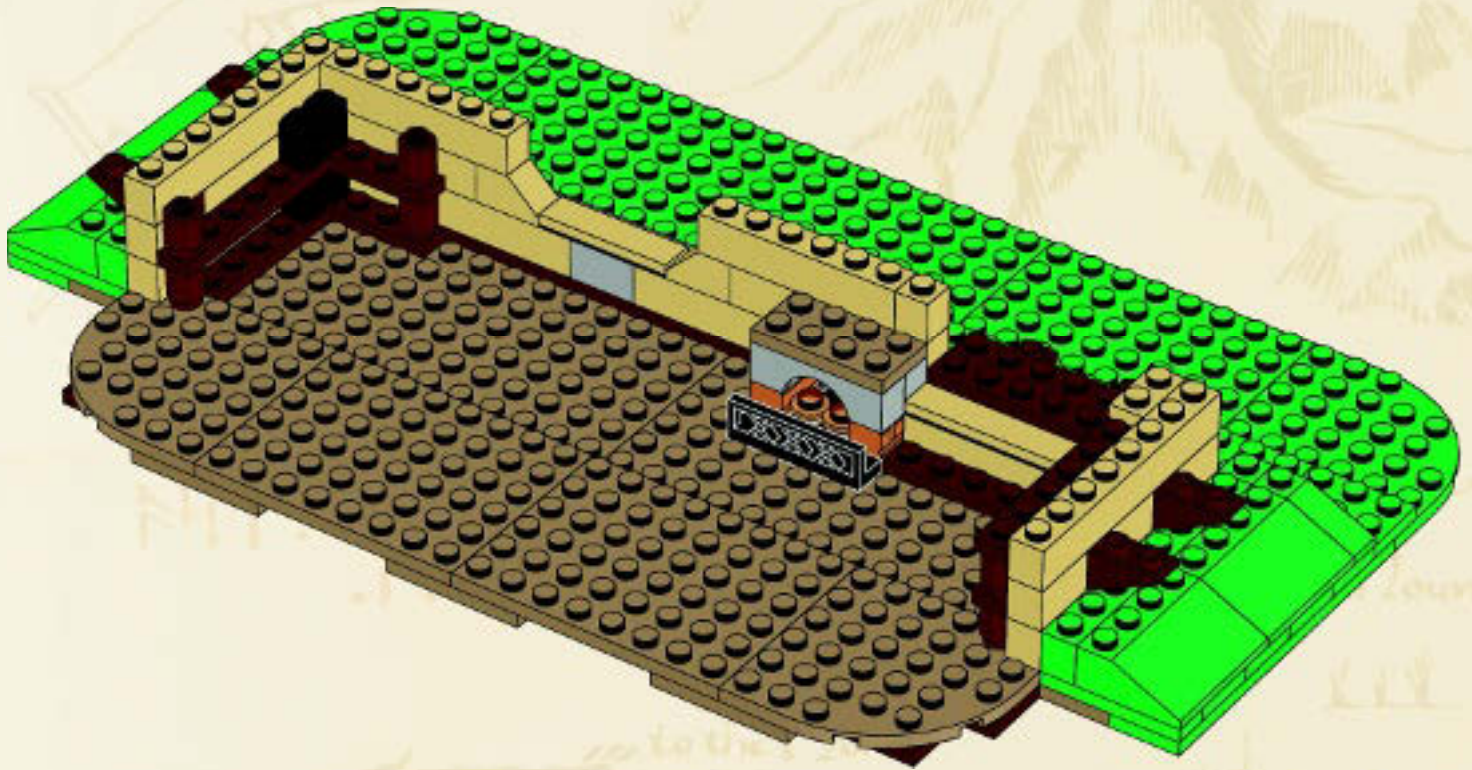

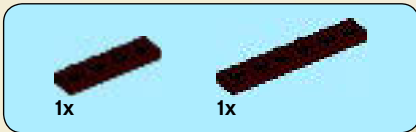

34

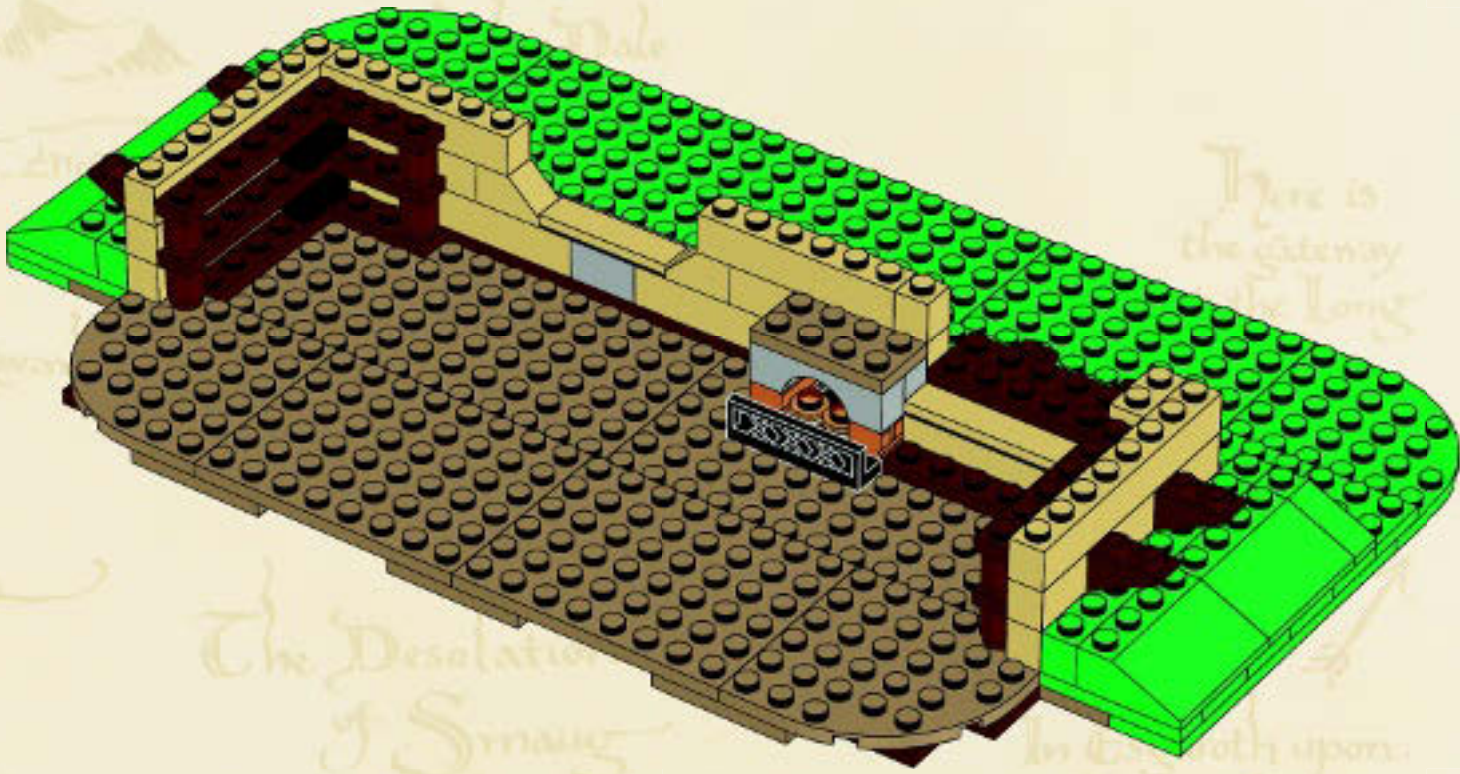

*From Hills
where is plain*

*Here was Girona
the Dale*

*There is the gateway
the Long*

*The Desolation
of Smaug*

*In a valley upon
the Long Lake
dwell Men*

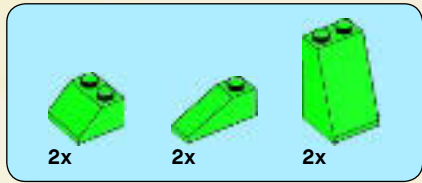

35

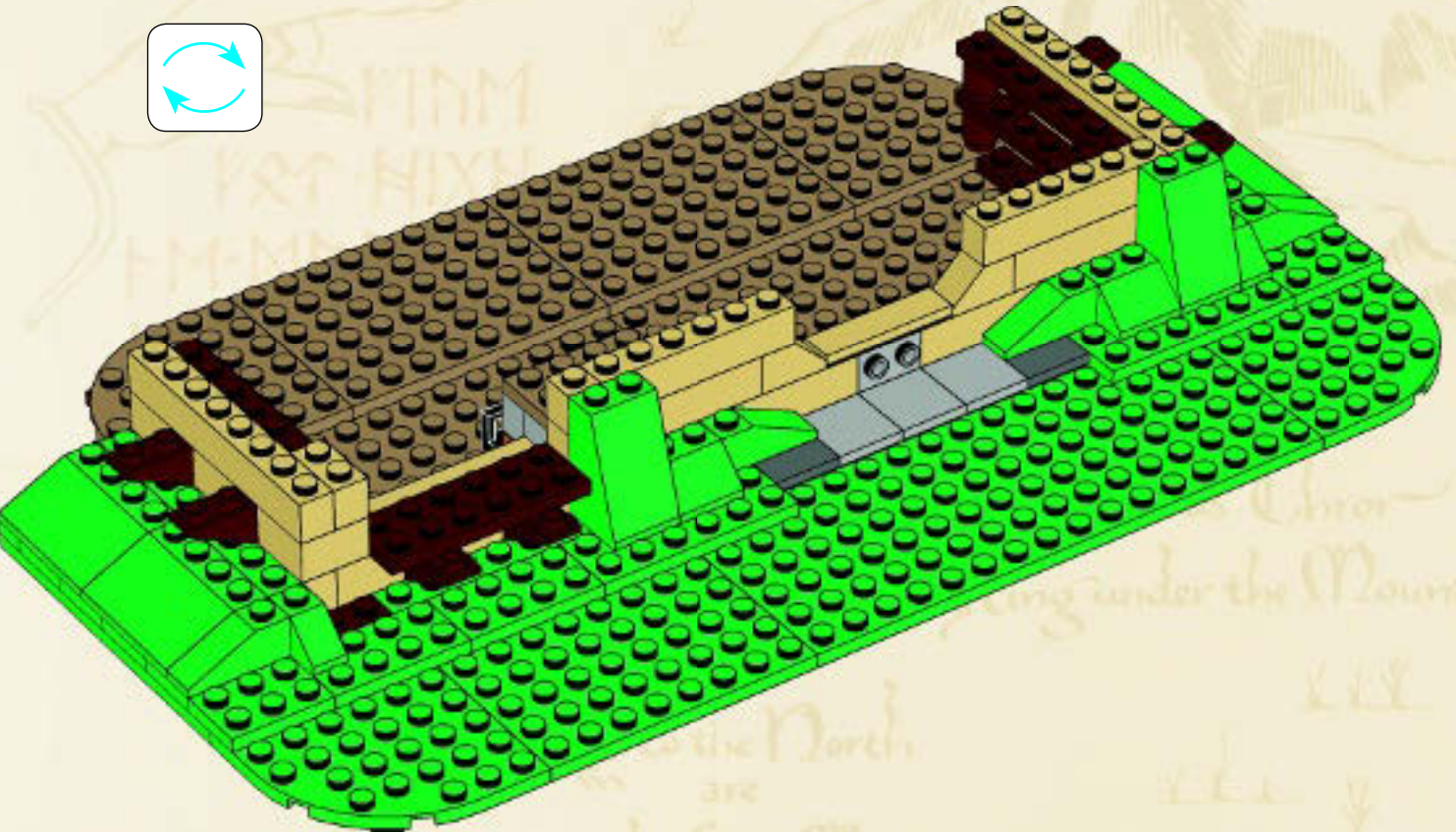

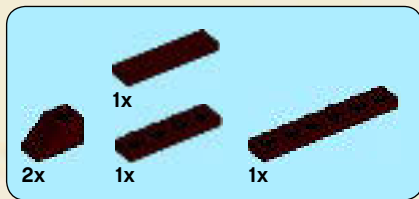

36

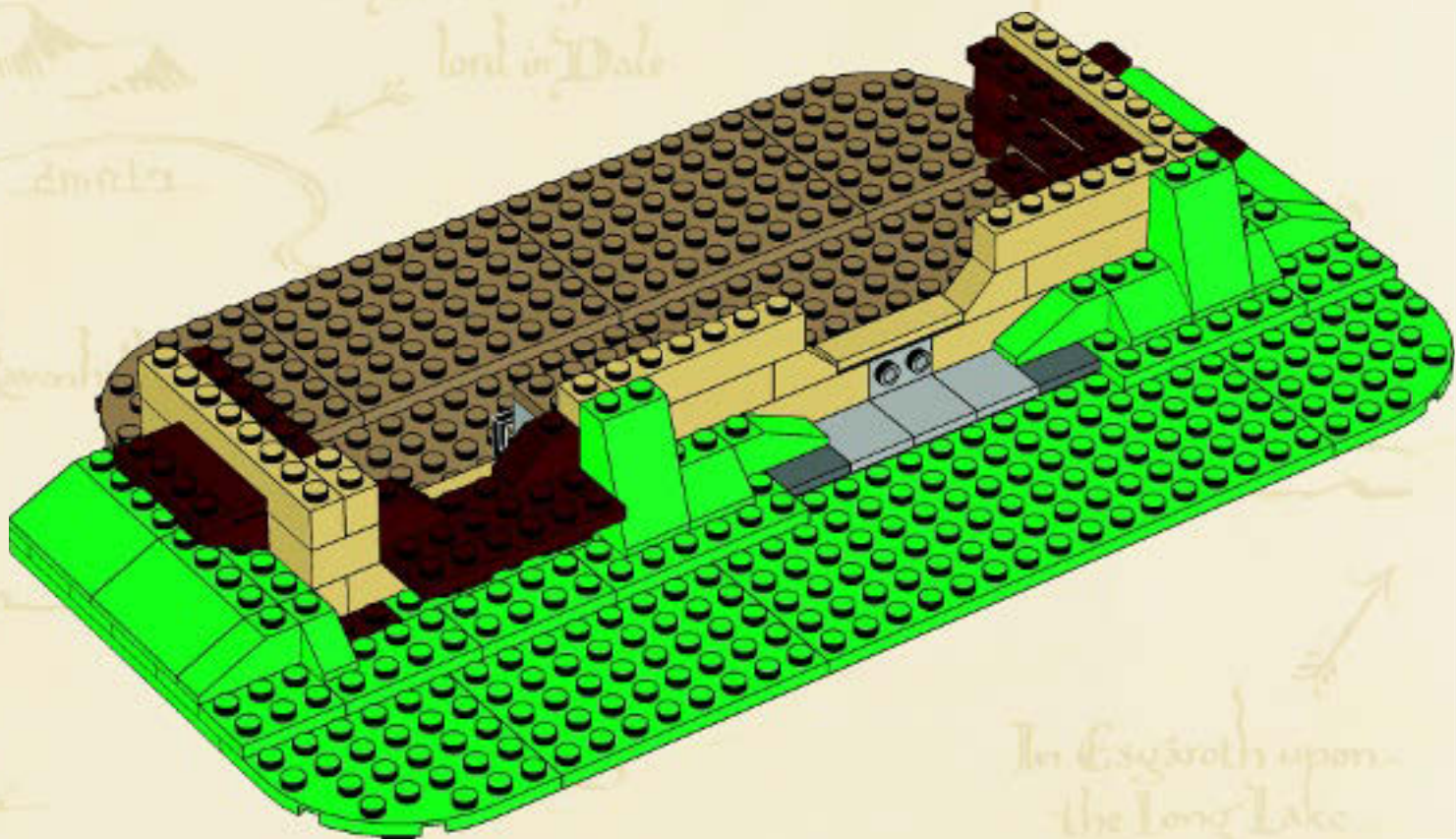



2x



2x

37

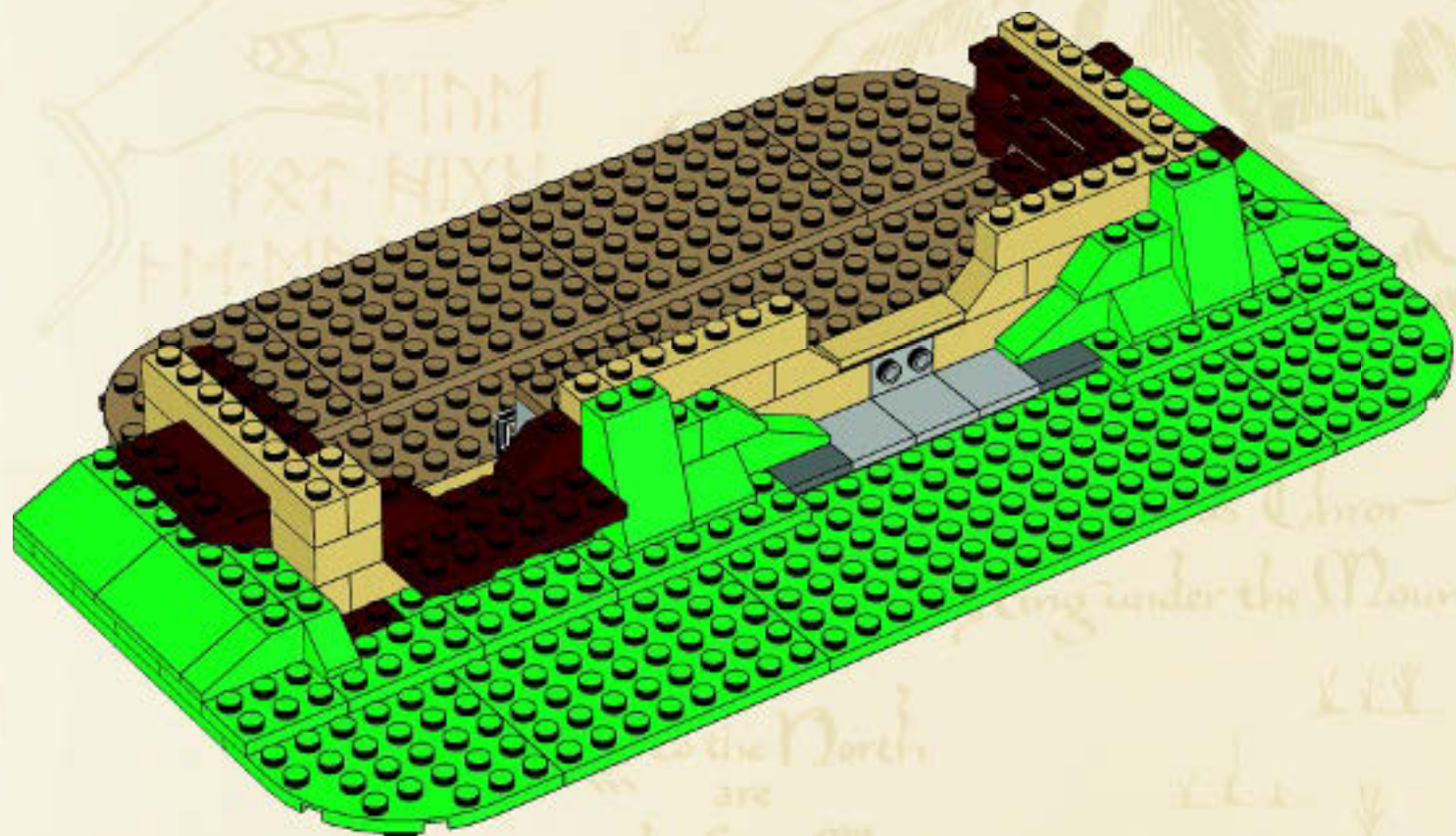

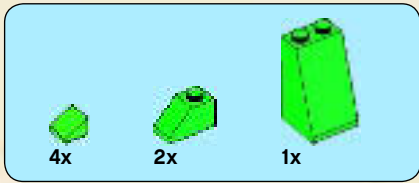

38

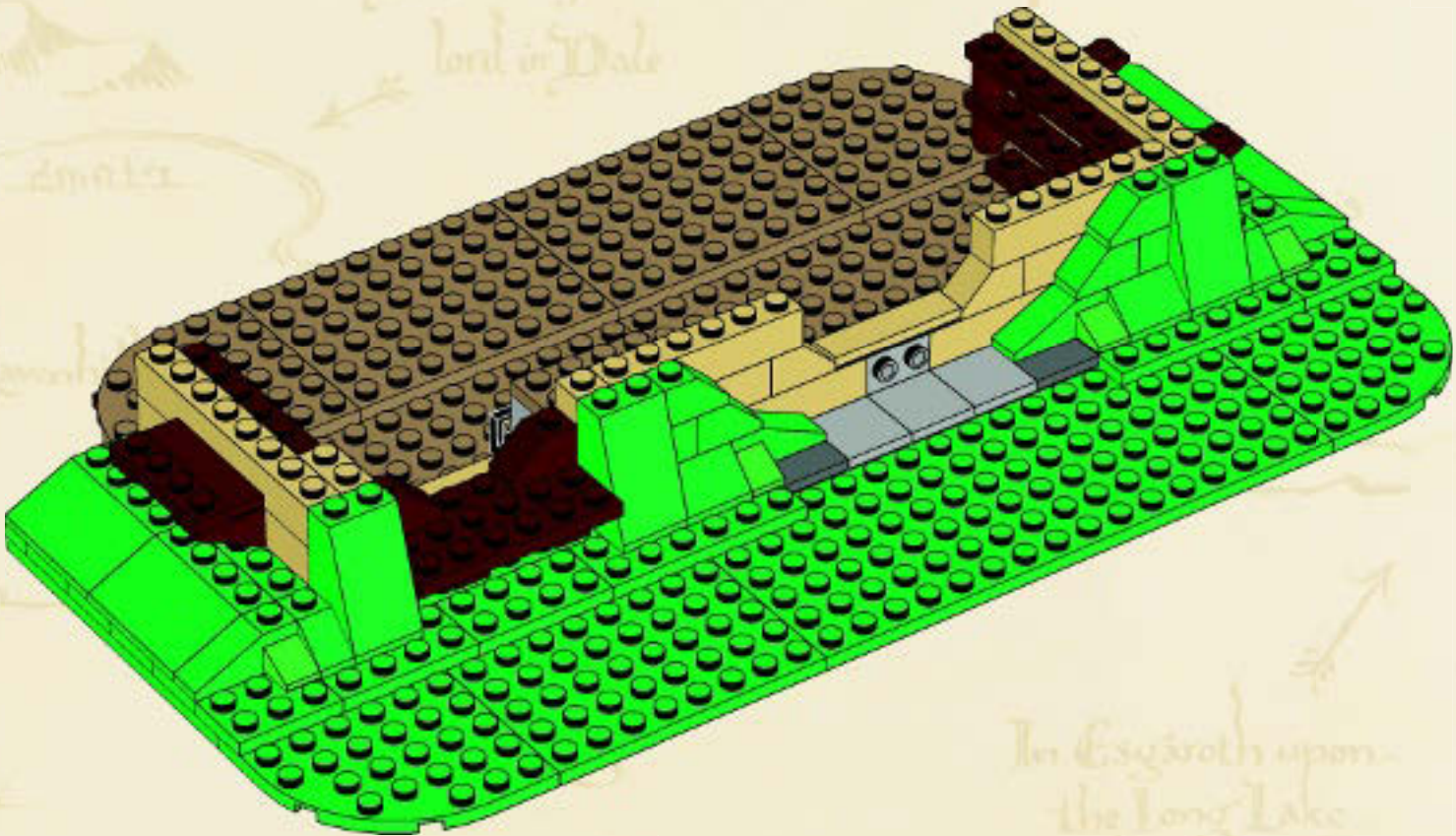

In Esqároth upon
the Long Lake
dwell Men

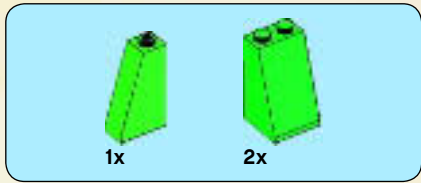

39

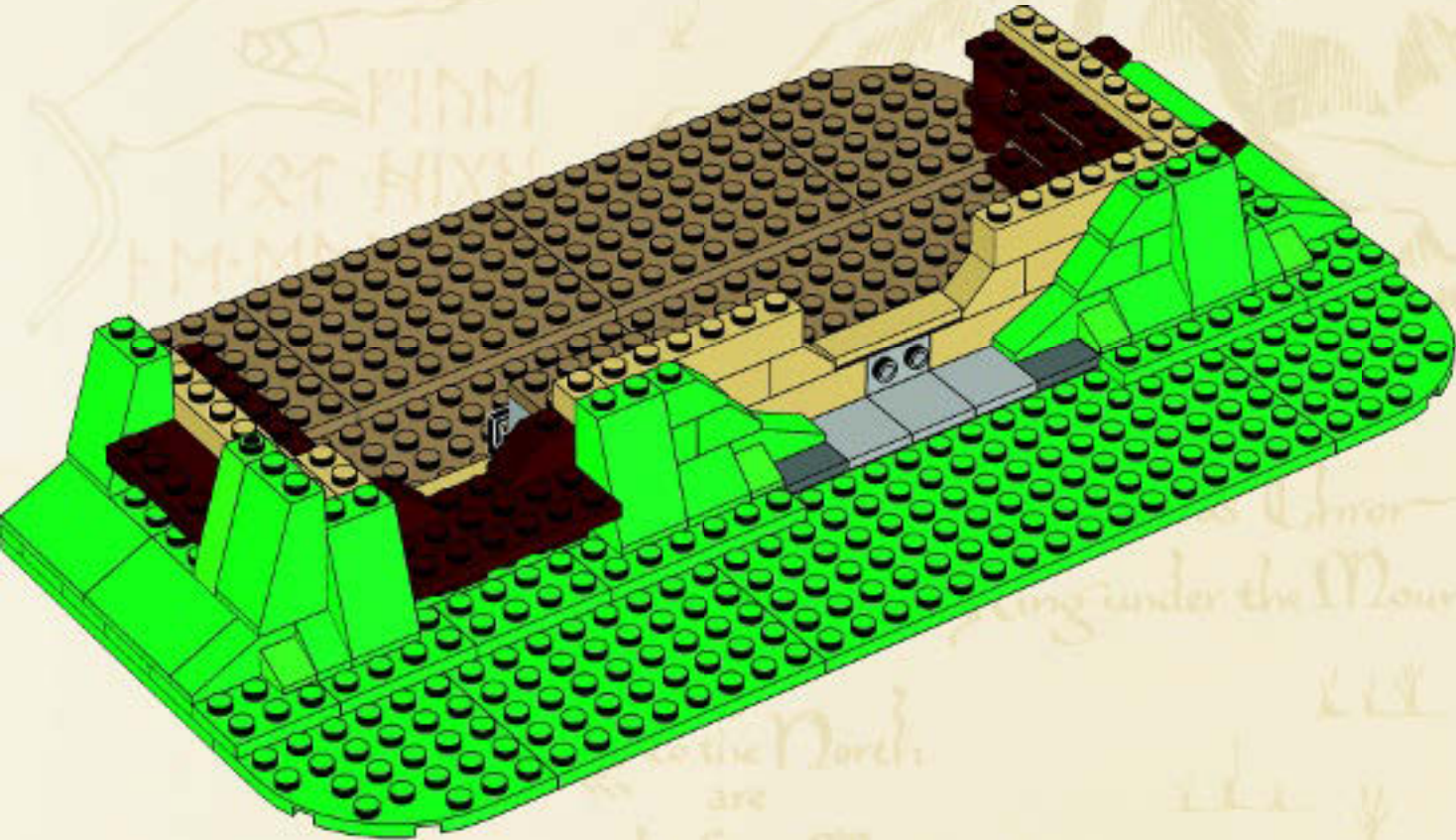

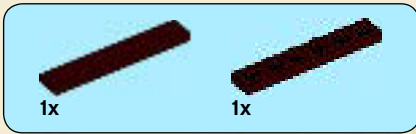

40

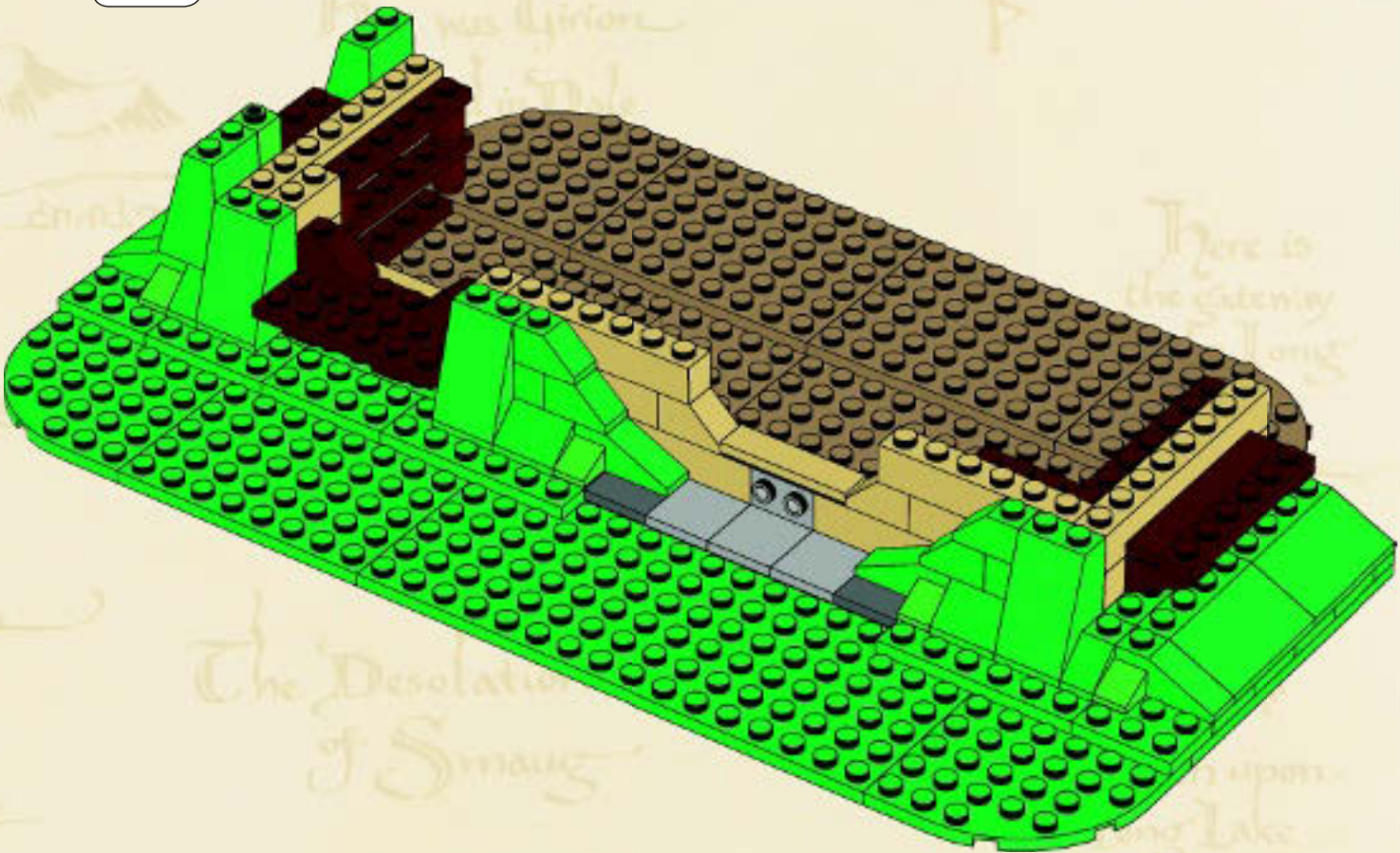

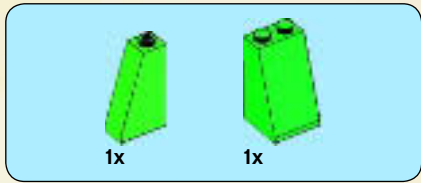

41

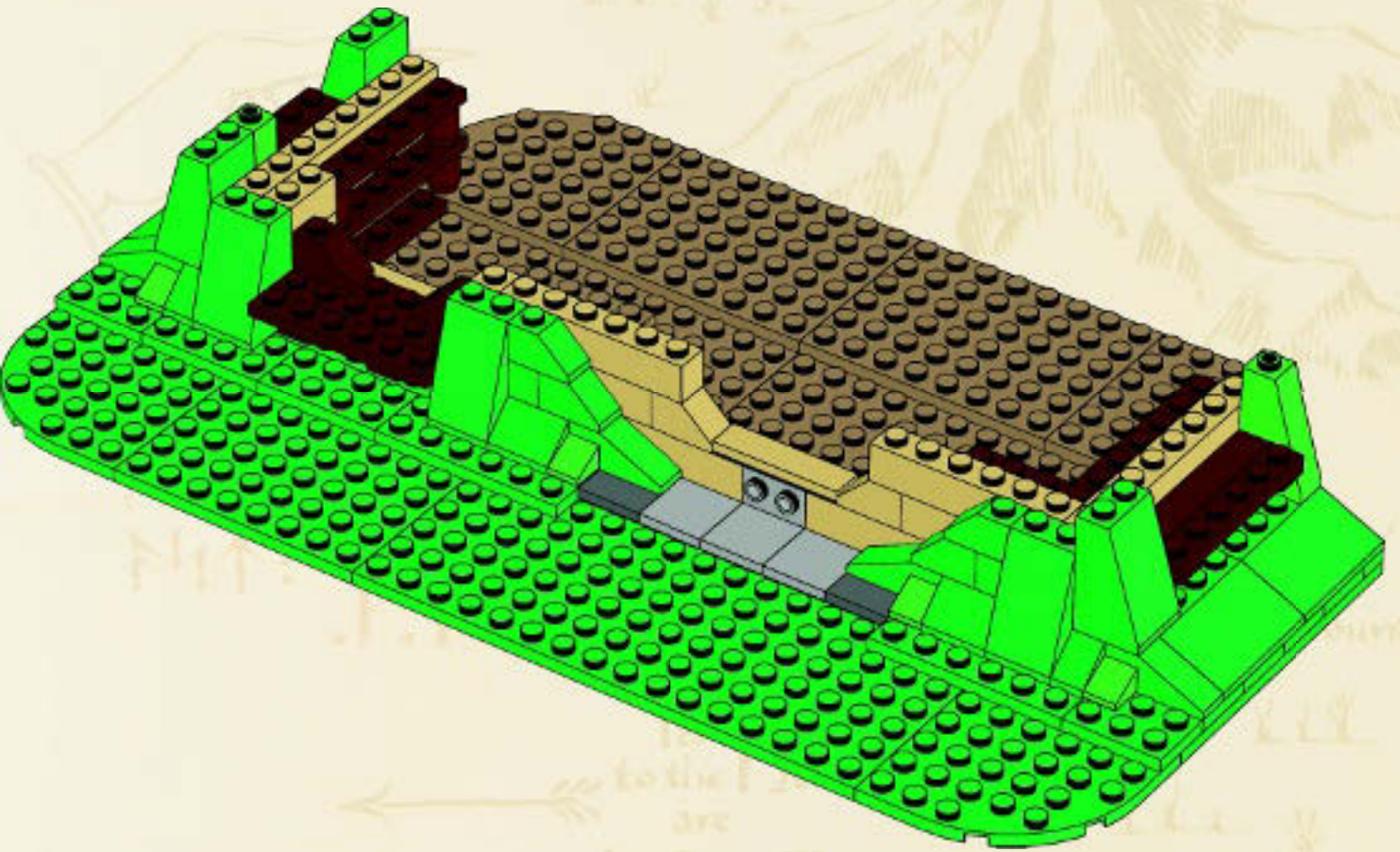

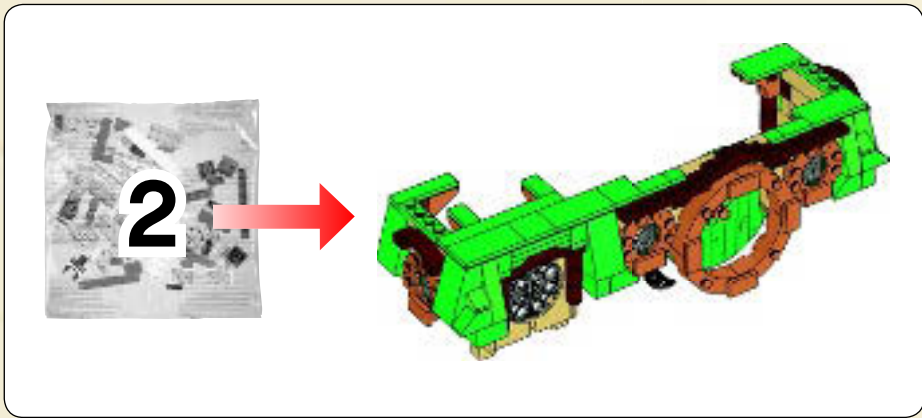

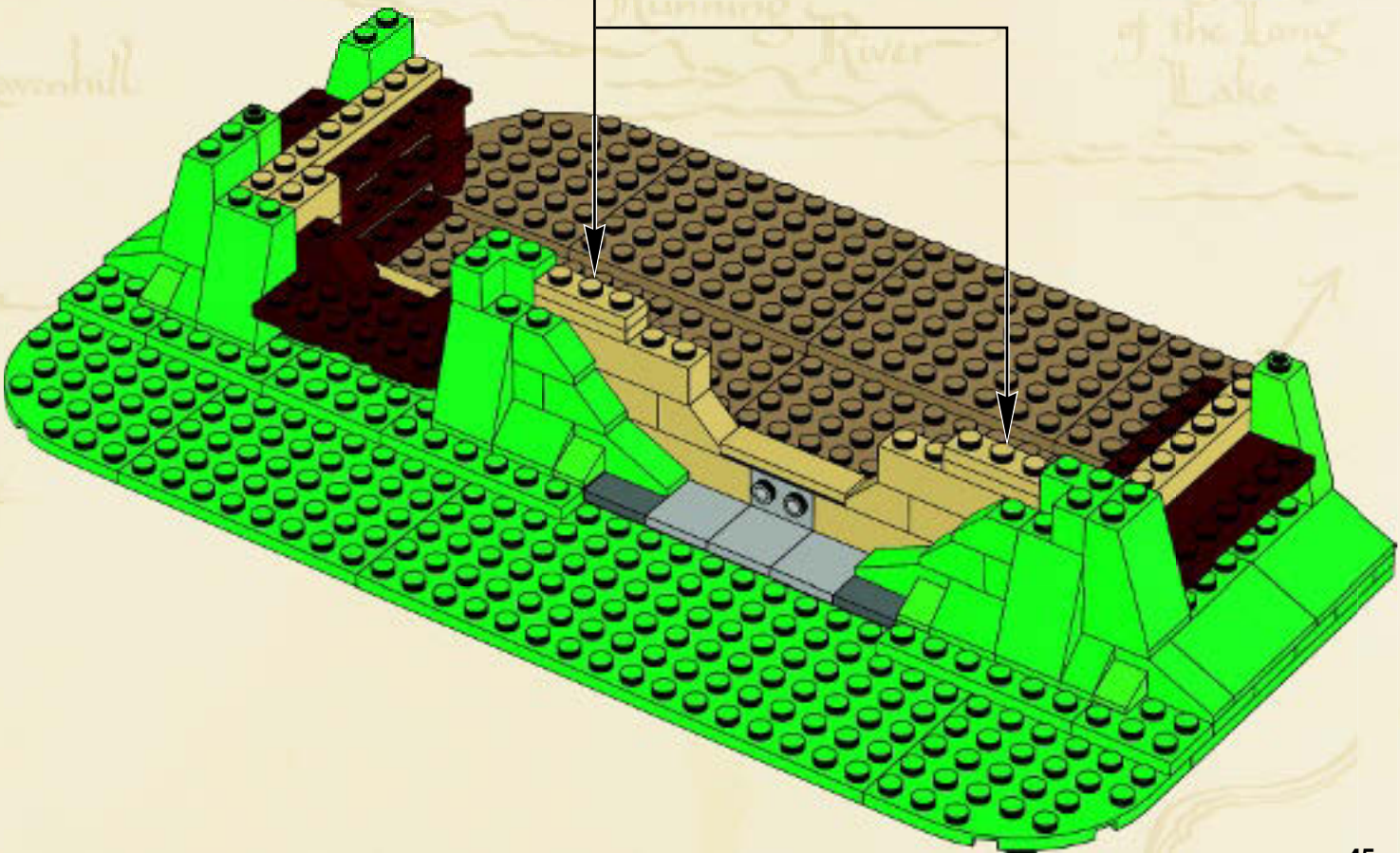
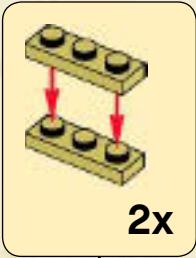

42



1x  1x  2x 

43

1  

2  

3  

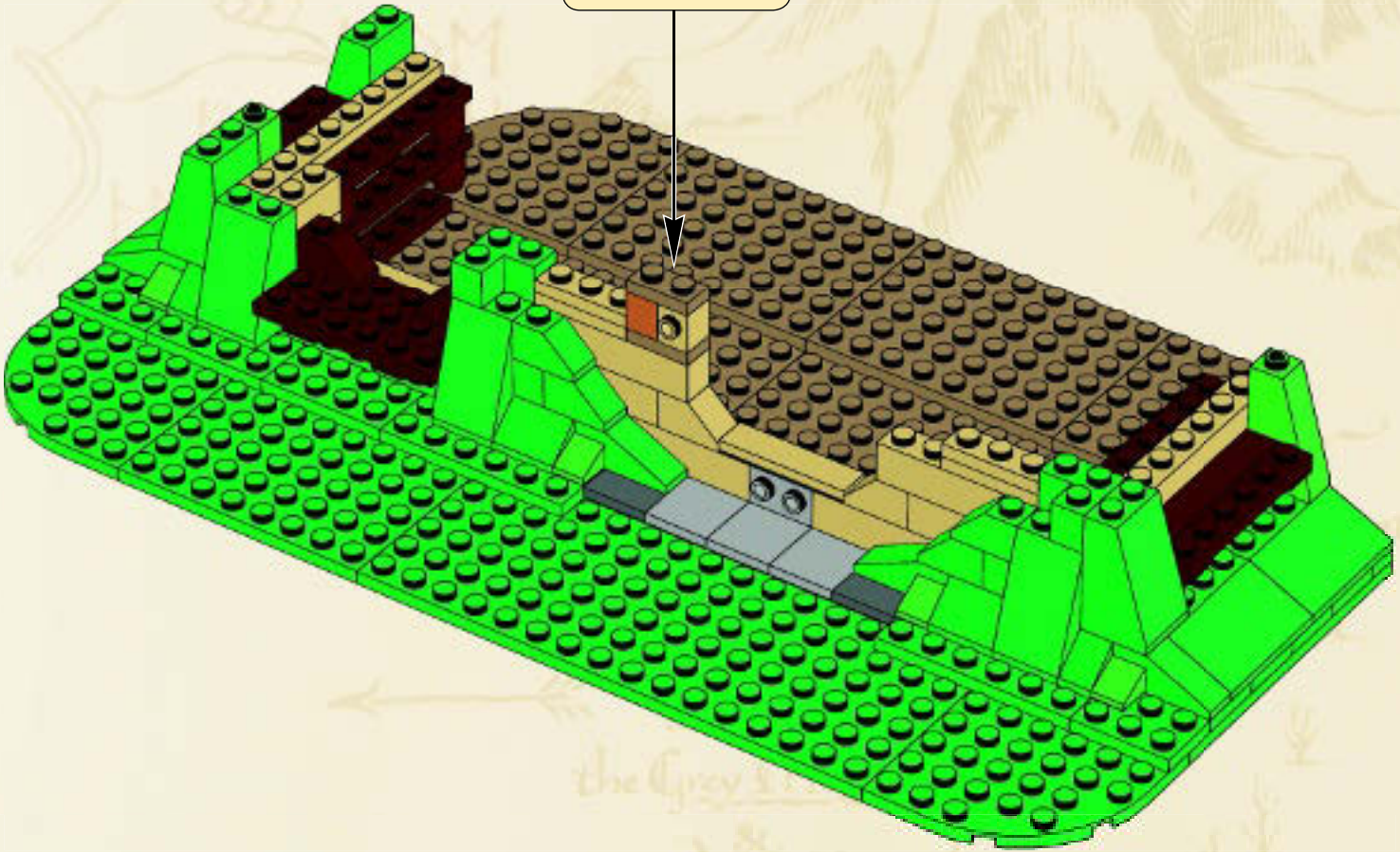

1x 1x 2x

44

- 1
- 2
- 3

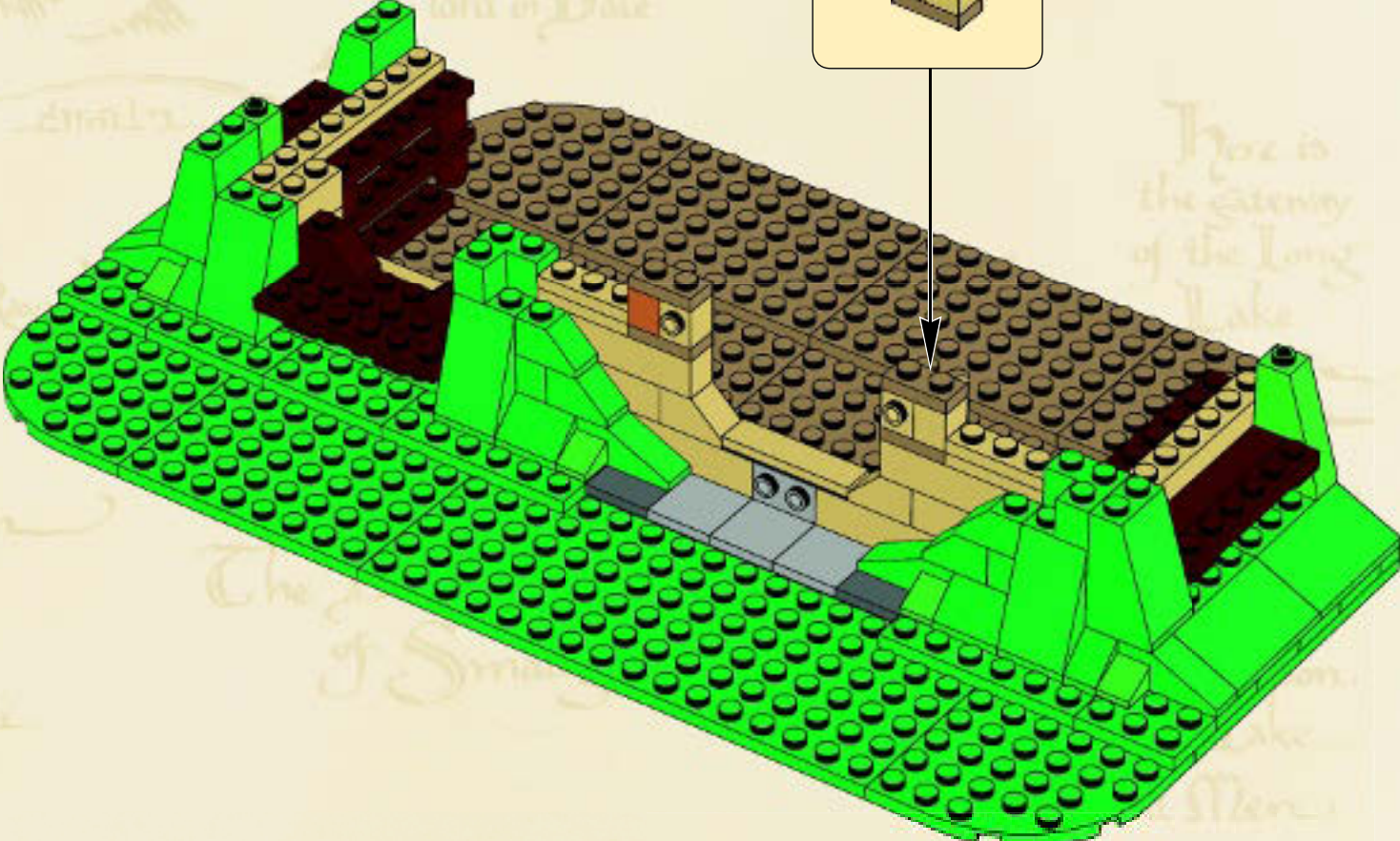

		
2x	2x	1x

45

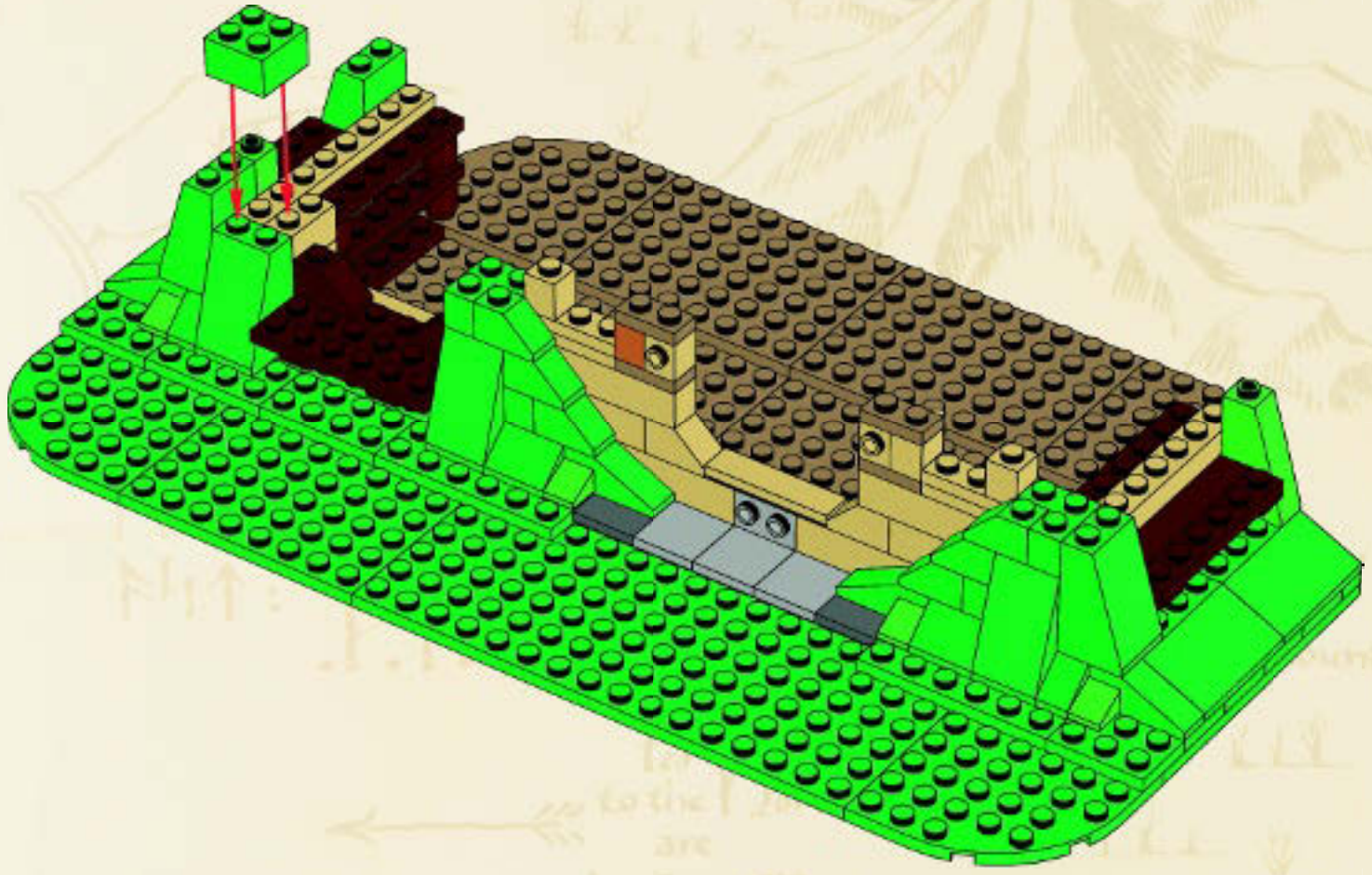



2x



2x

46

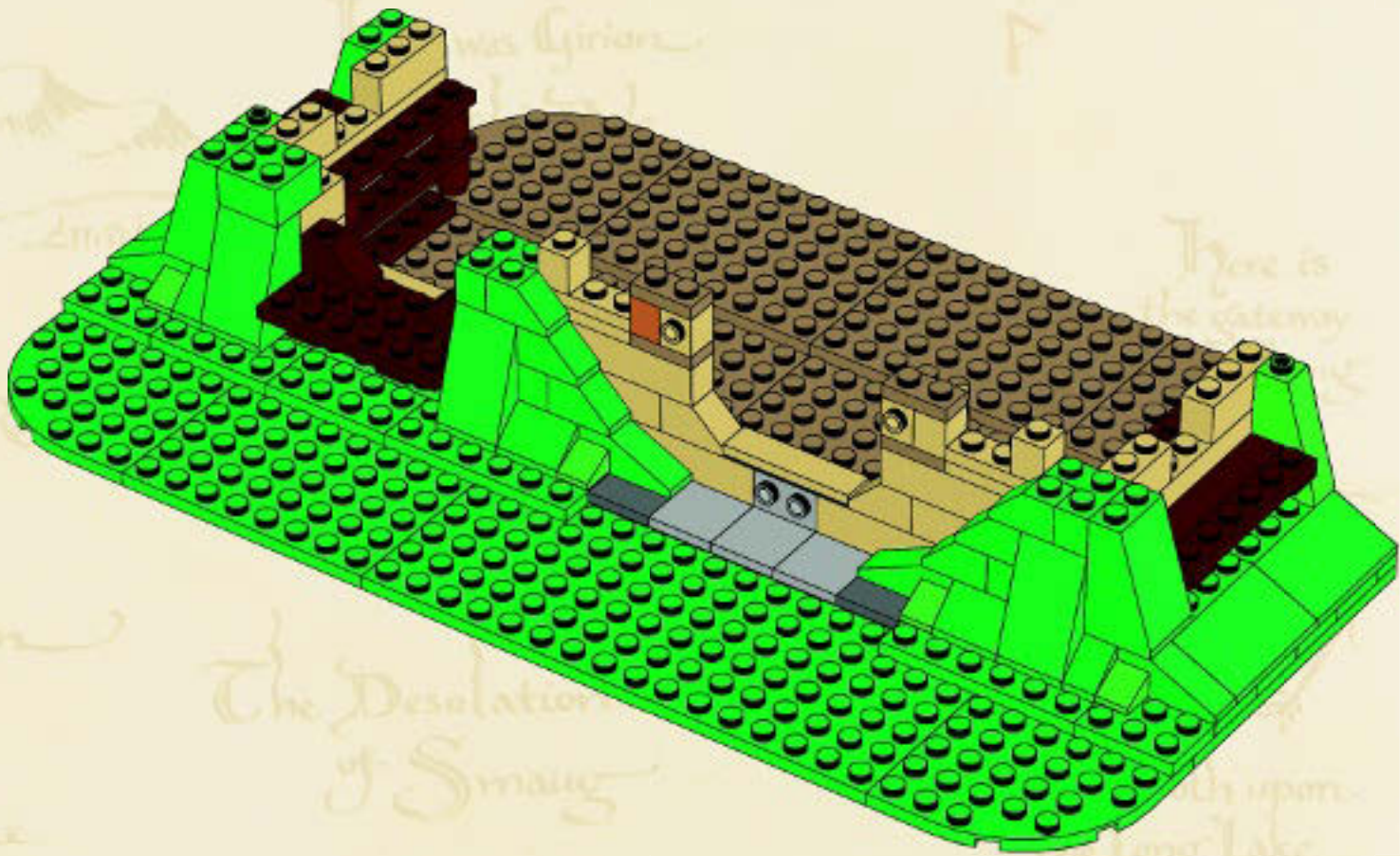

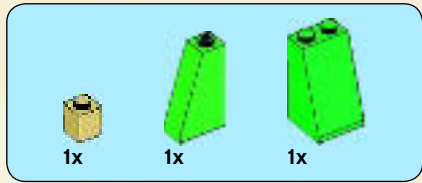

47

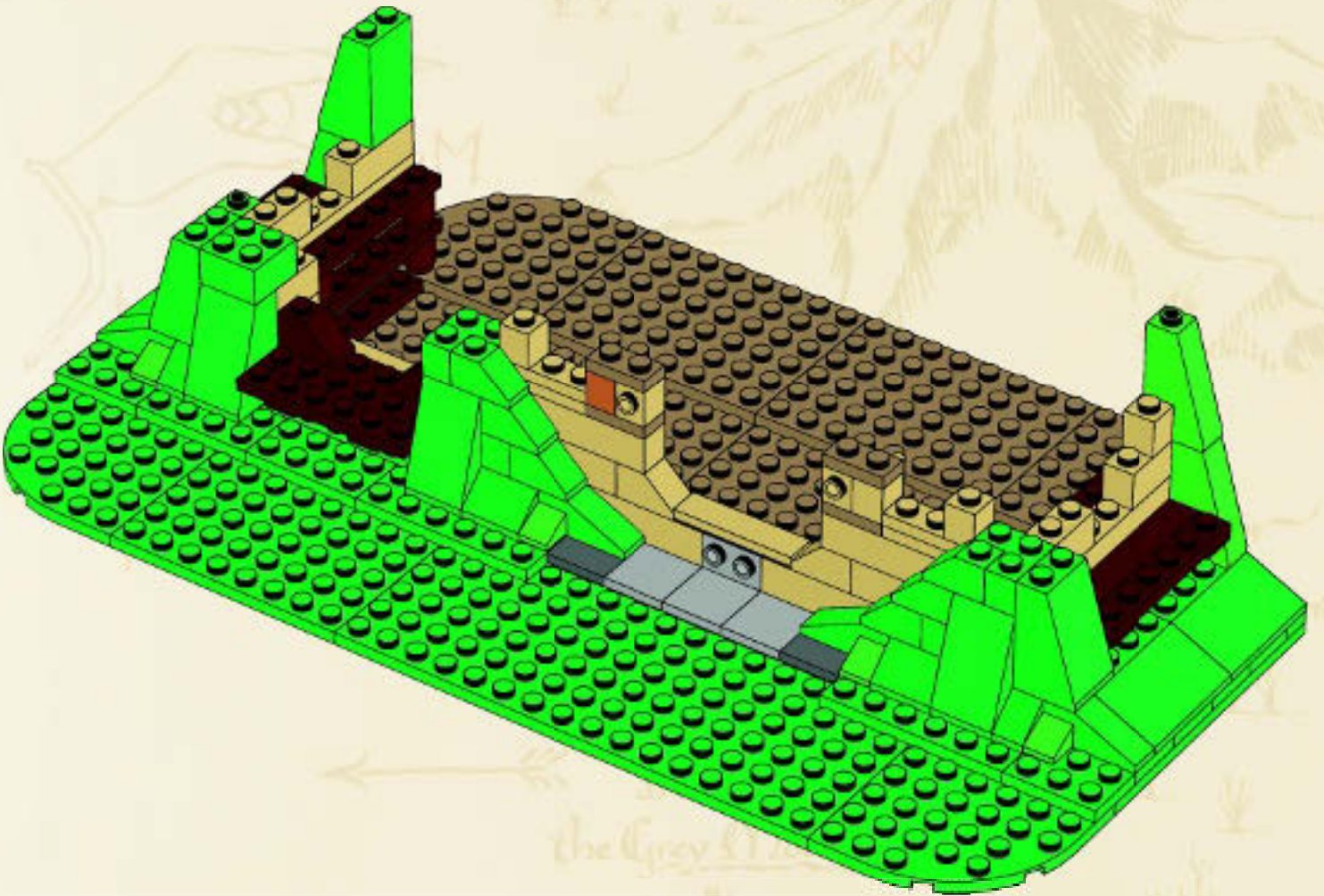



48

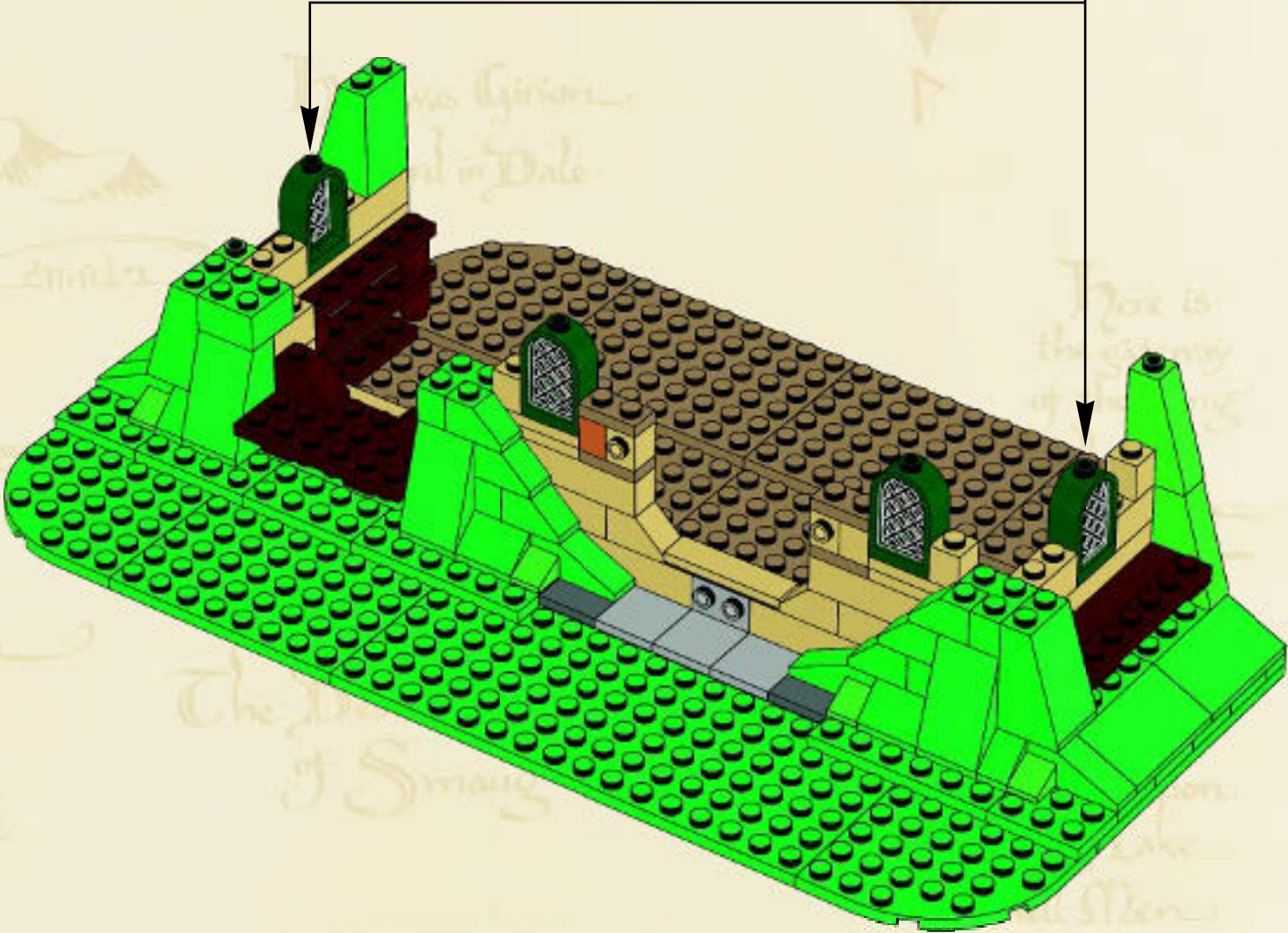



49

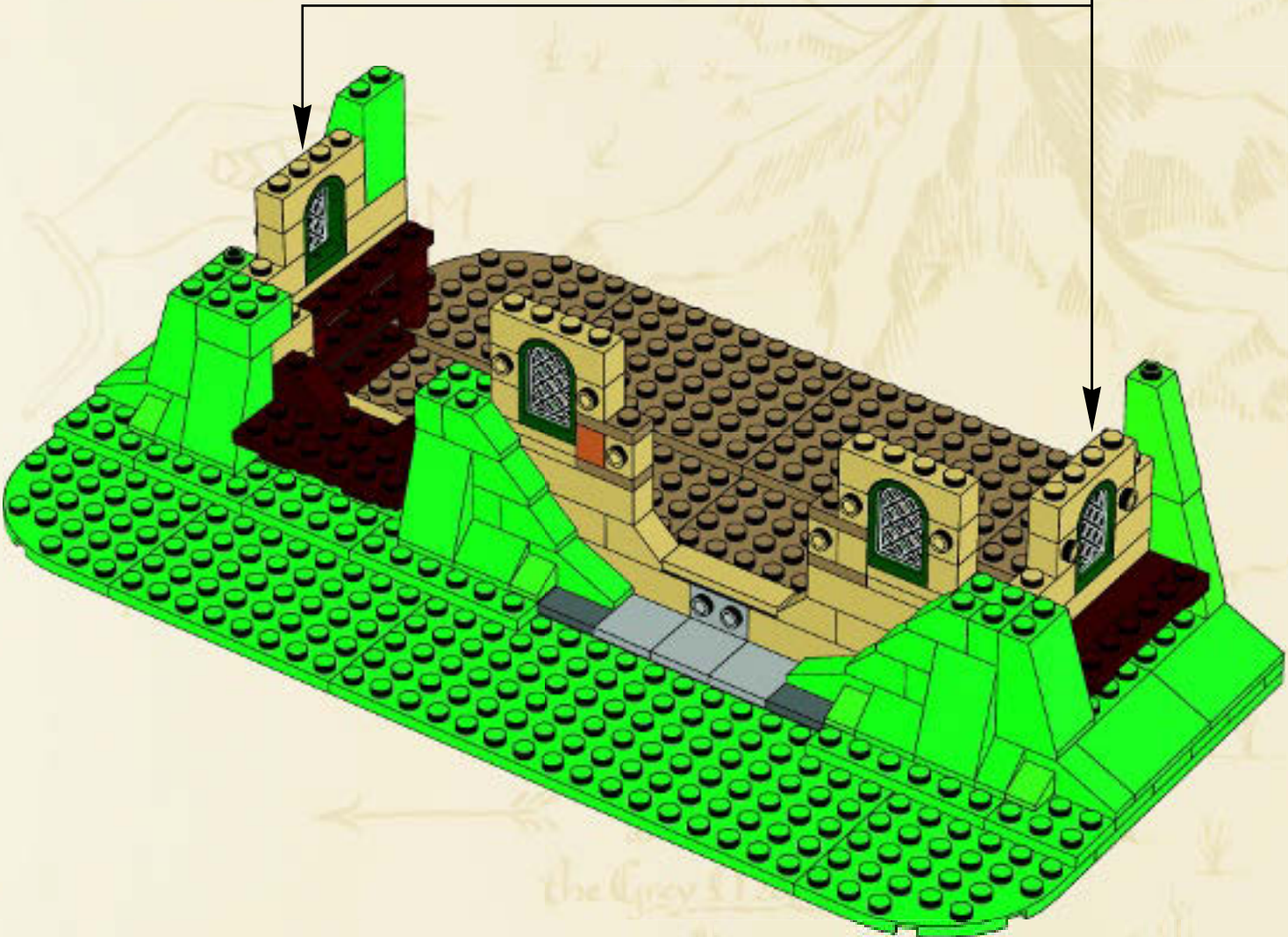
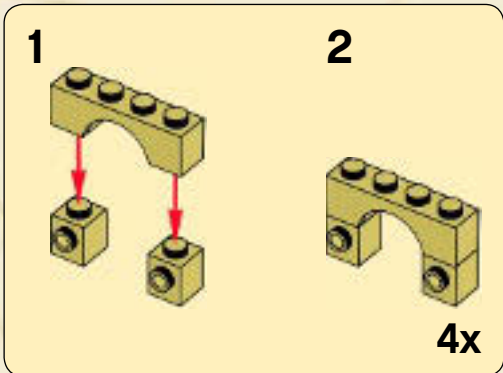



1x



2x

50

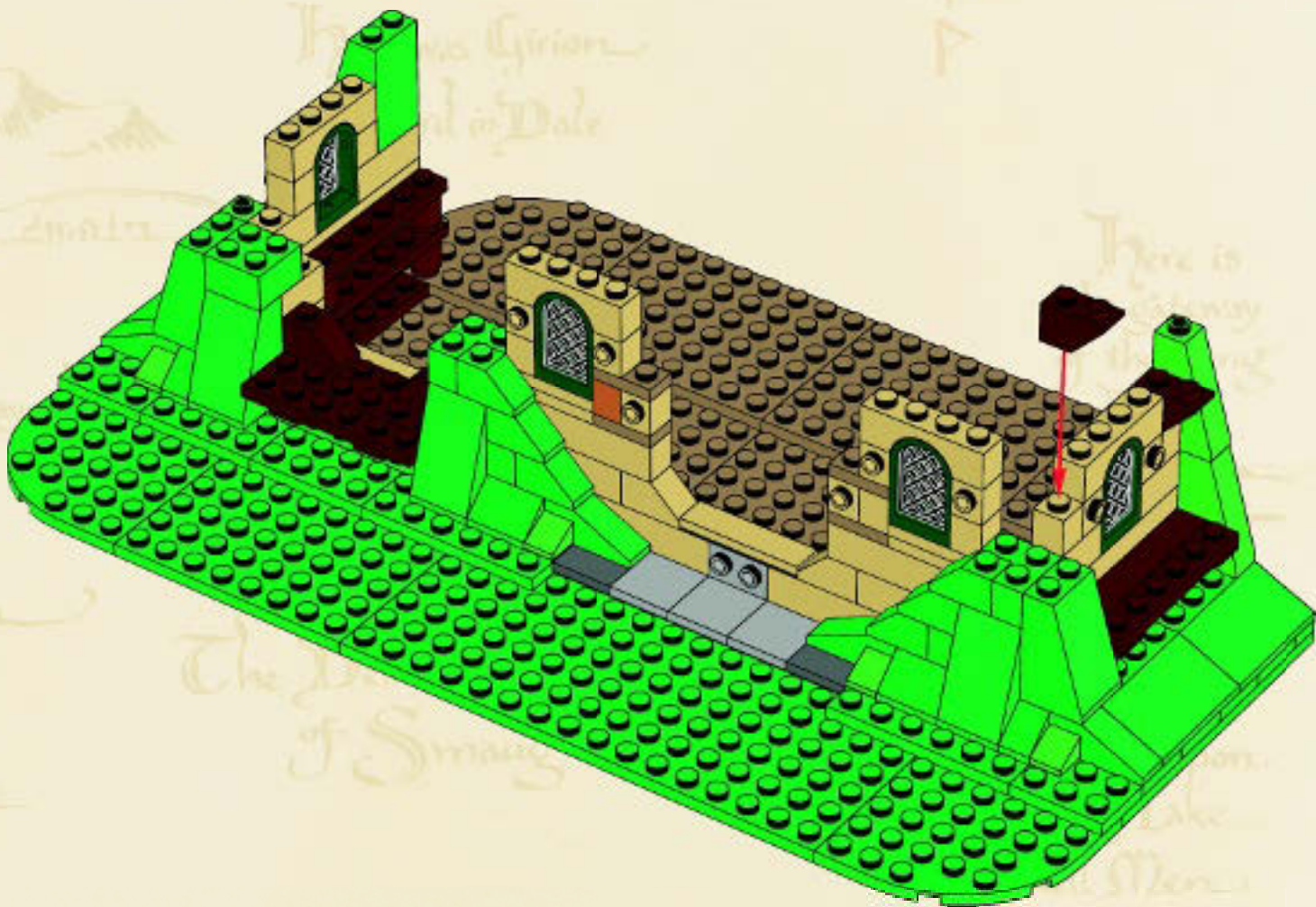

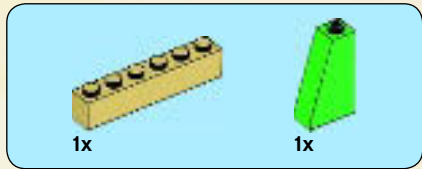

51

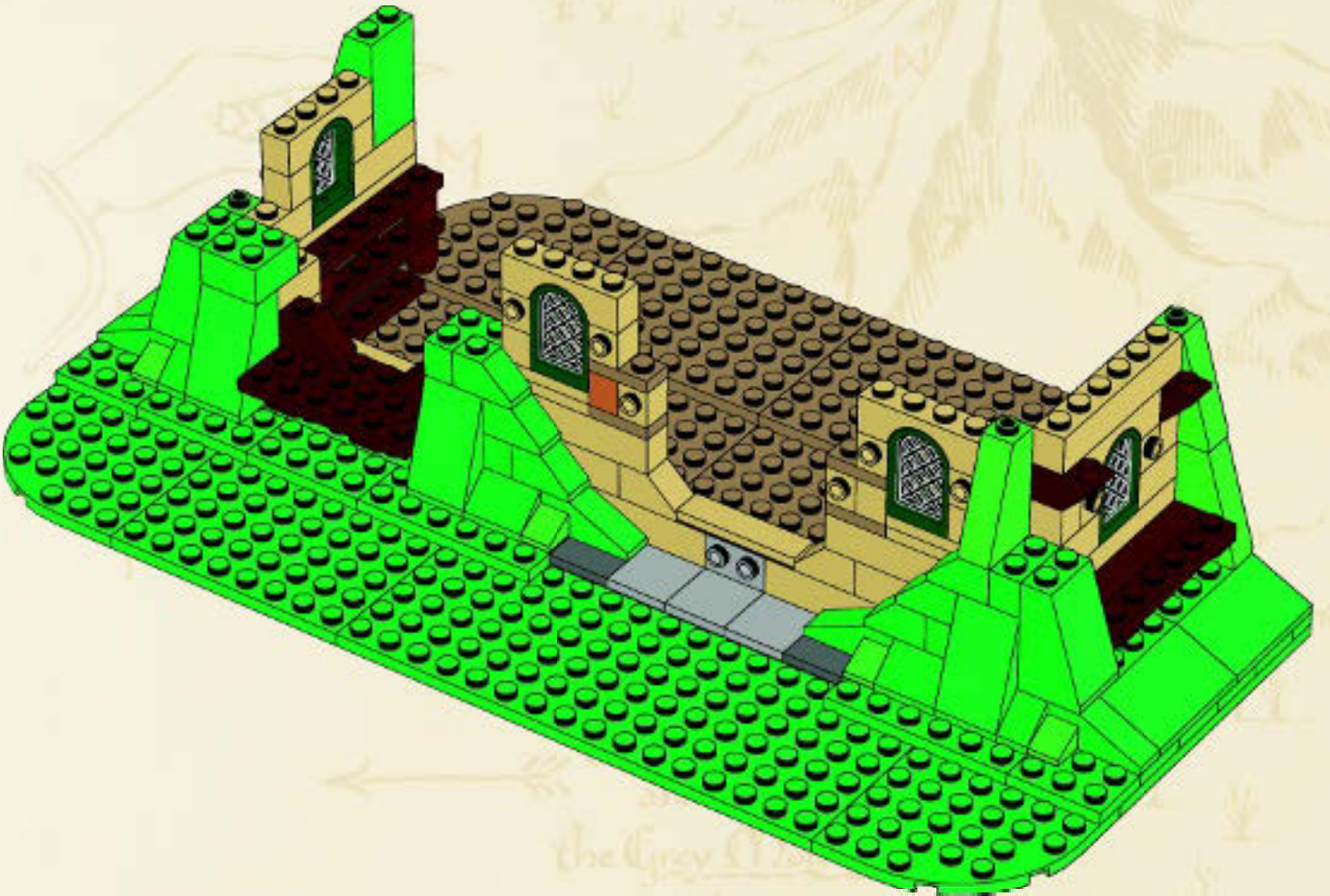

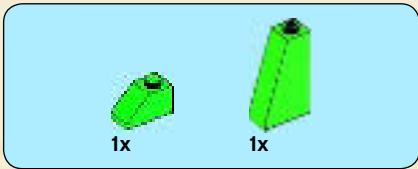

52

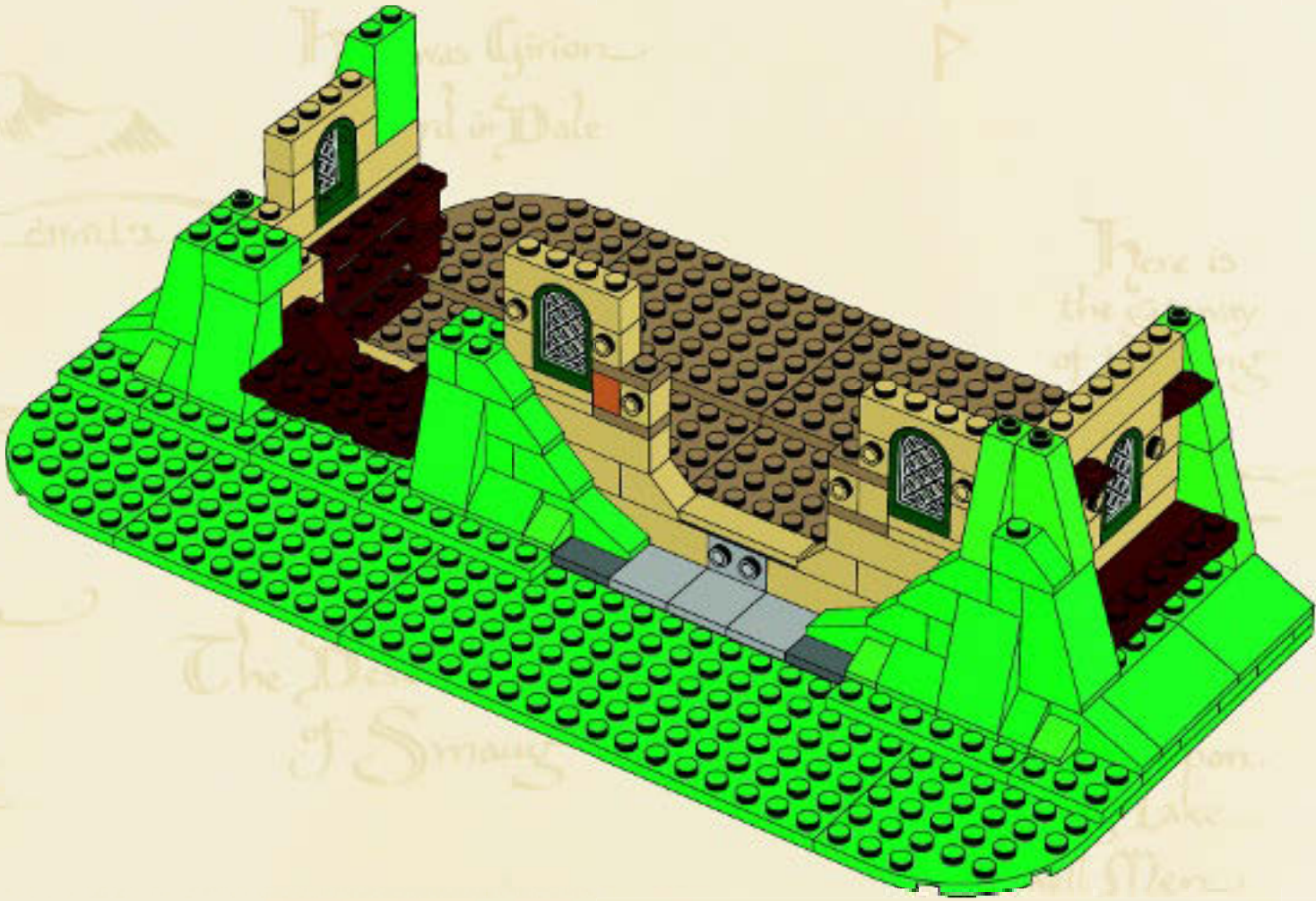



1x



2x

53

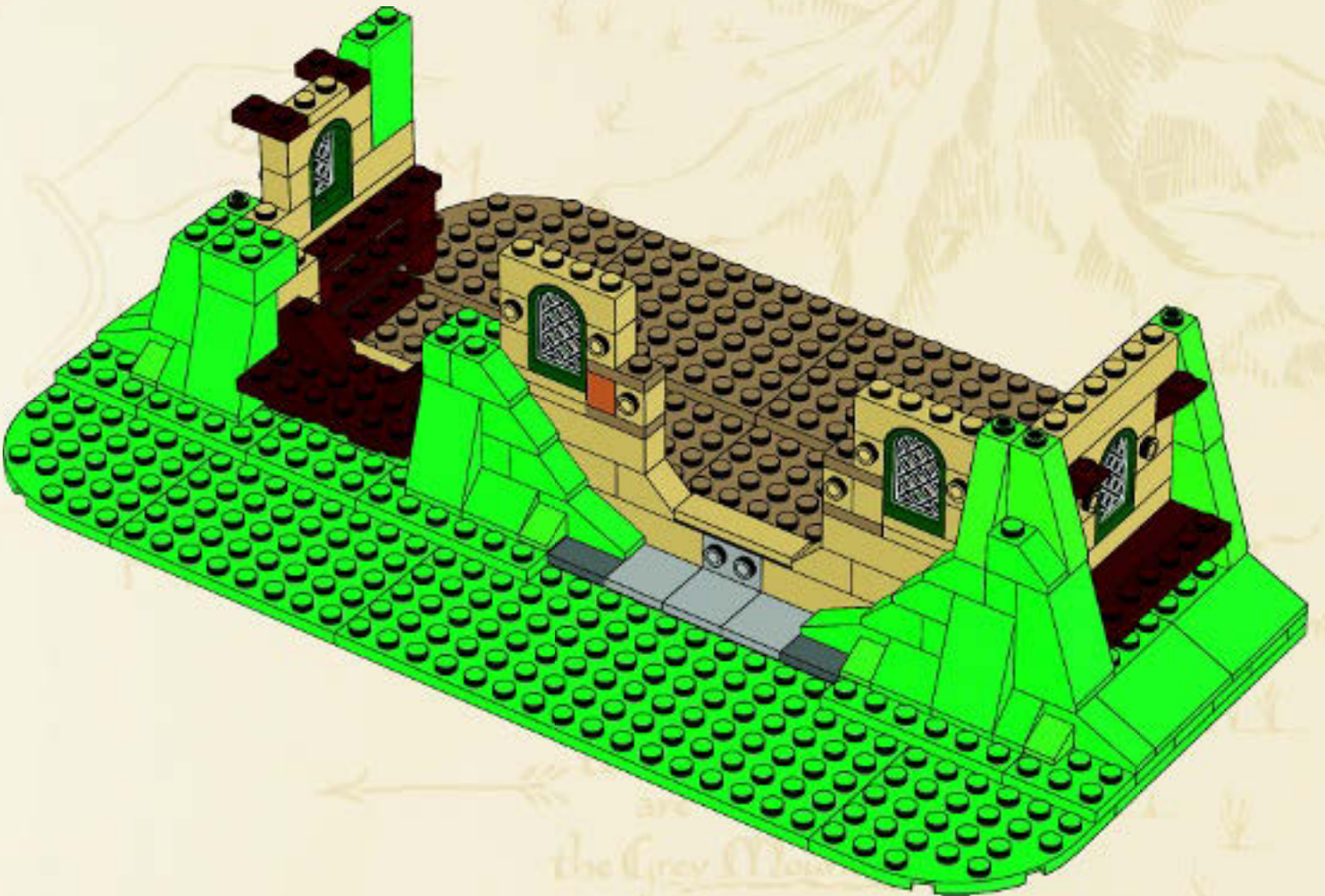

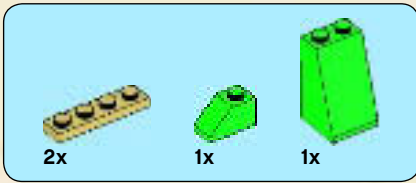

54

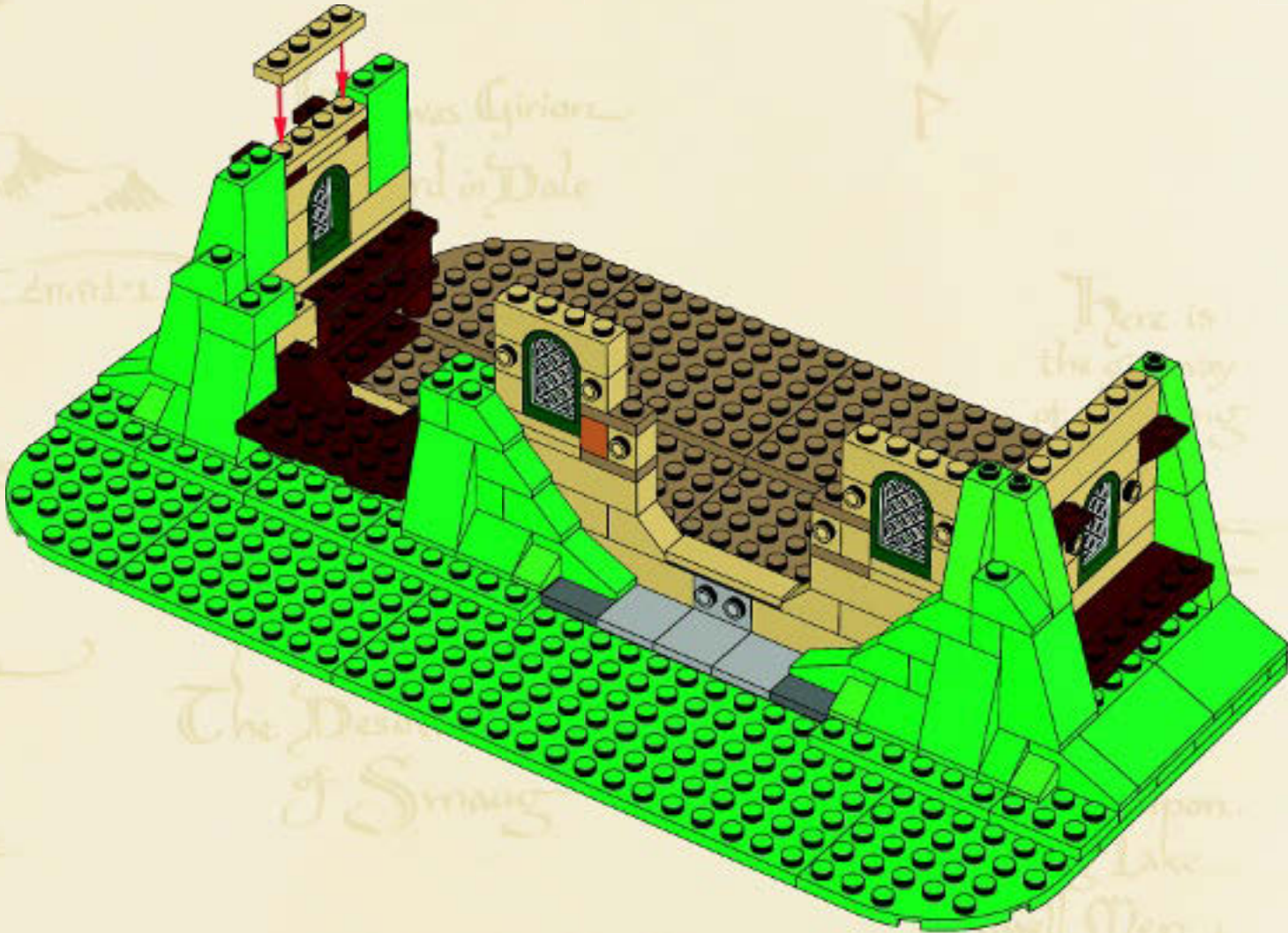

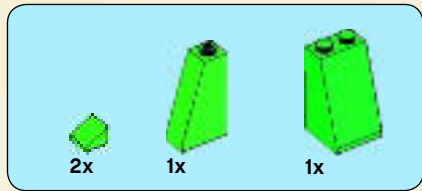

55

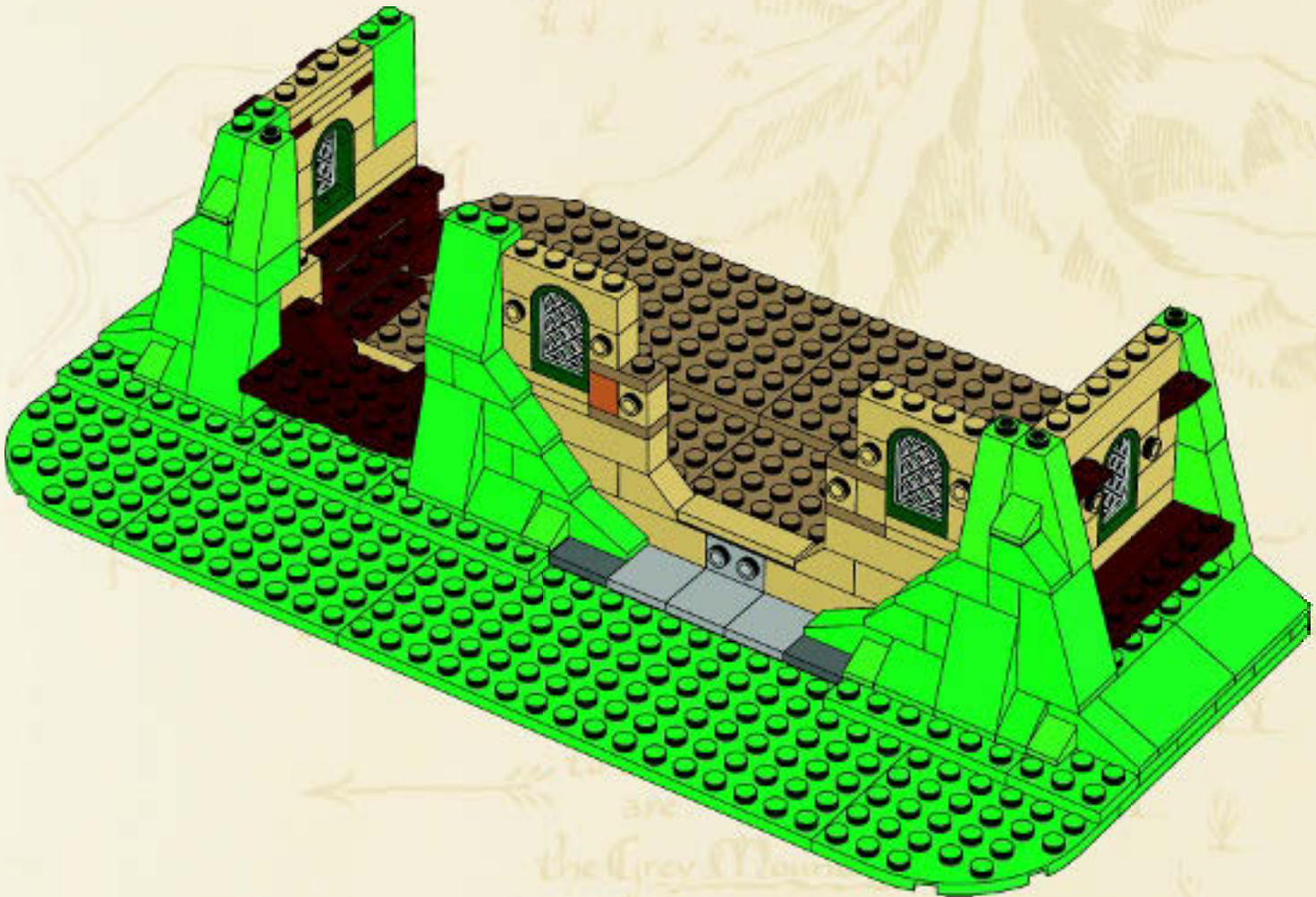

6x

56

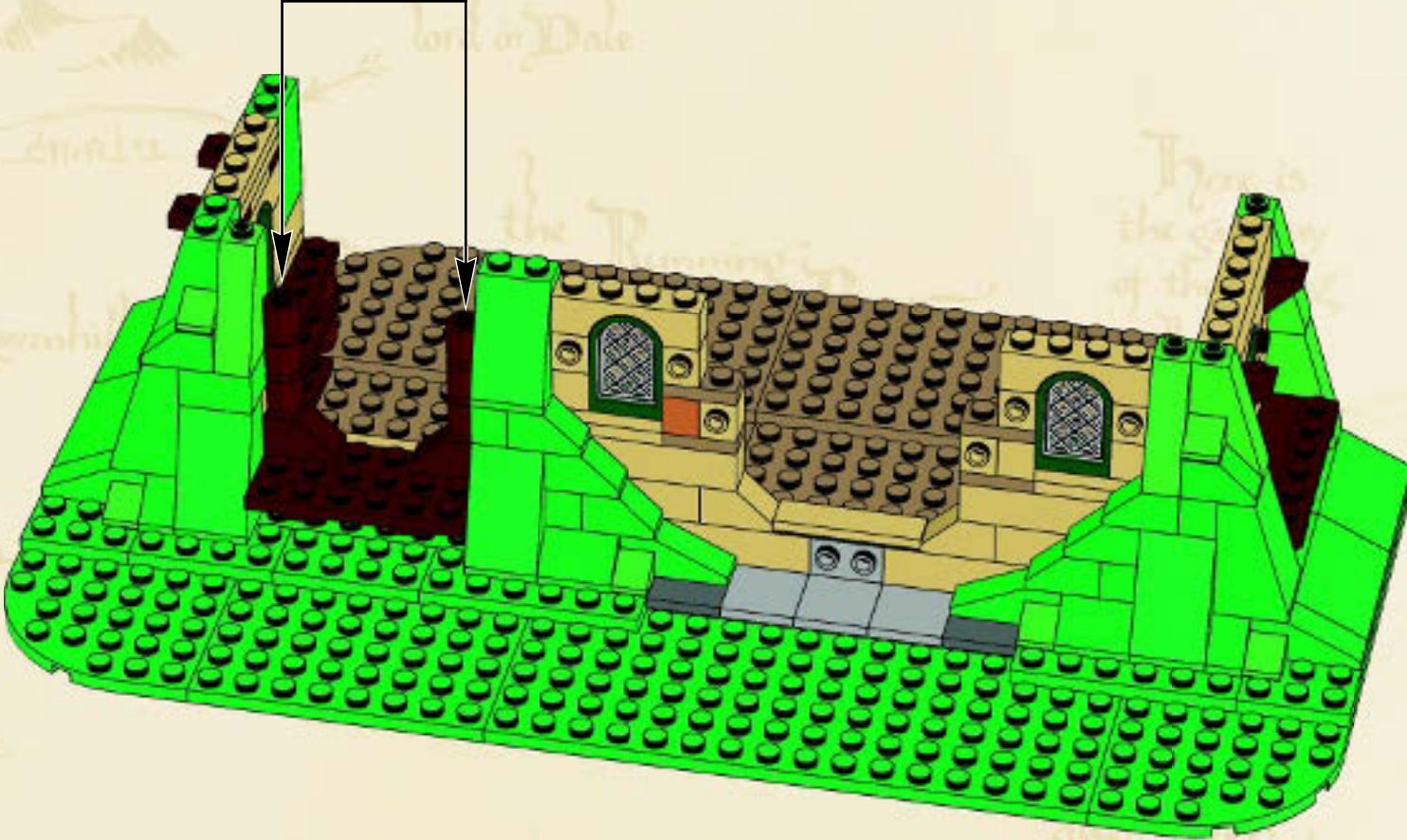
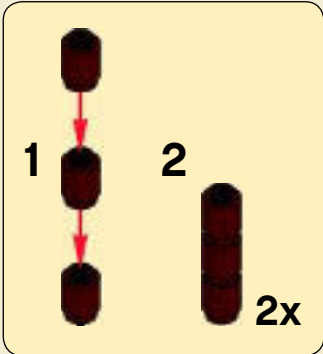

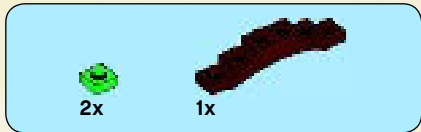



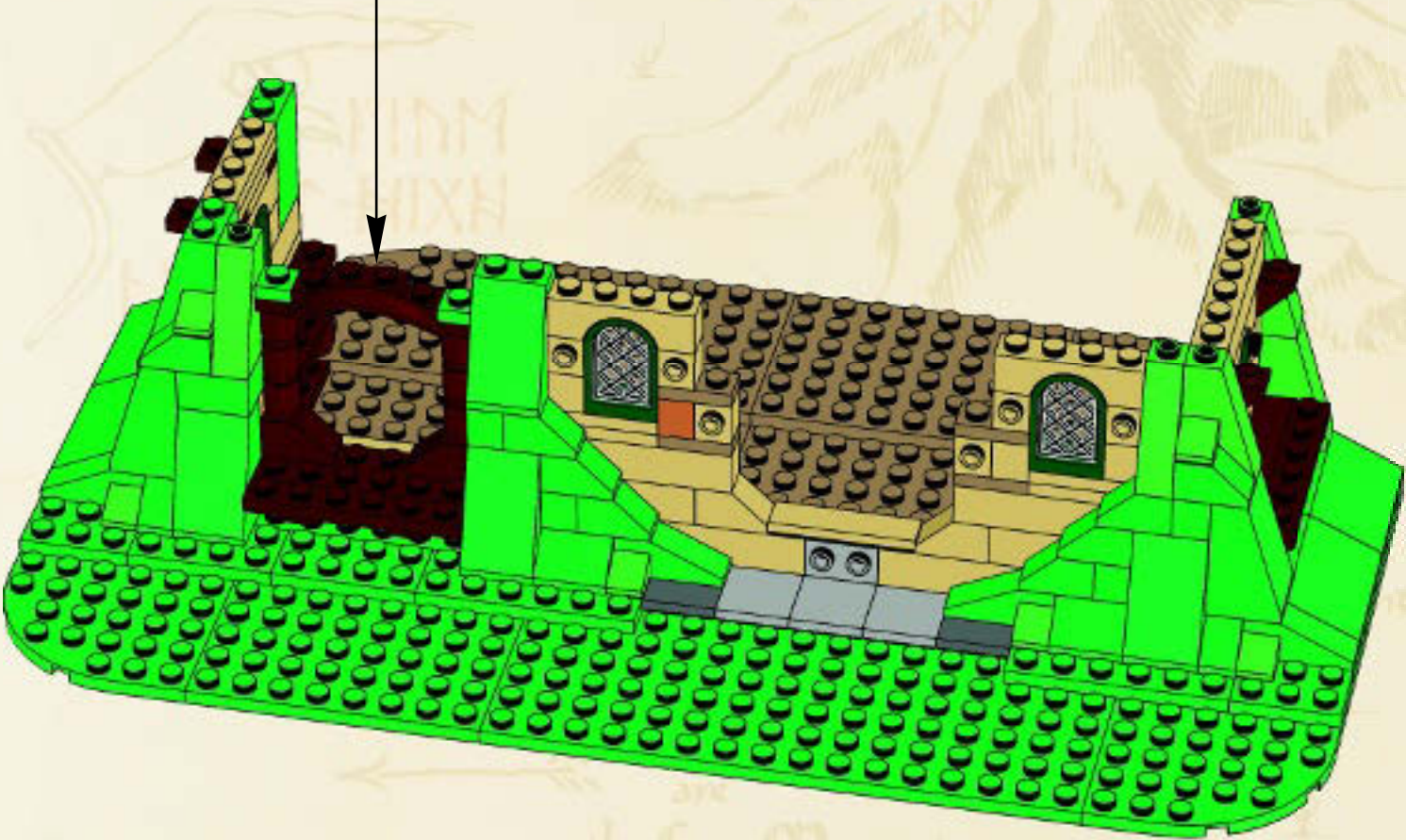
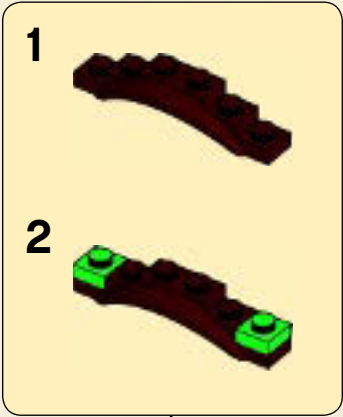

57

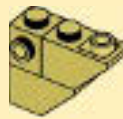

 2x	 2x	 4x
--	--	--

58

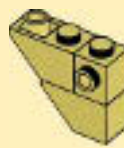
- 1 
- 2 
- 3 

- 1 
- 2 
- 3 

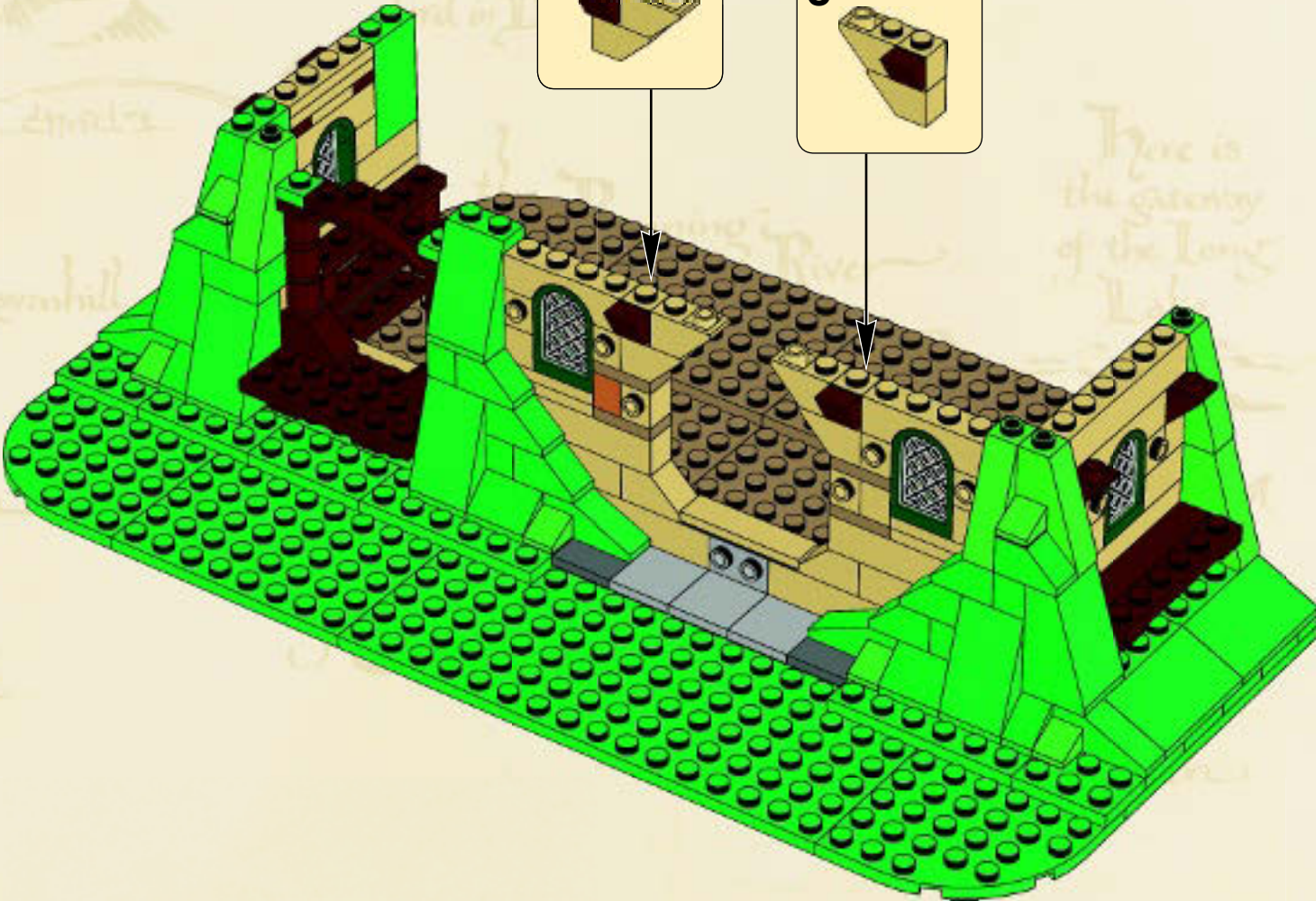

2x

59

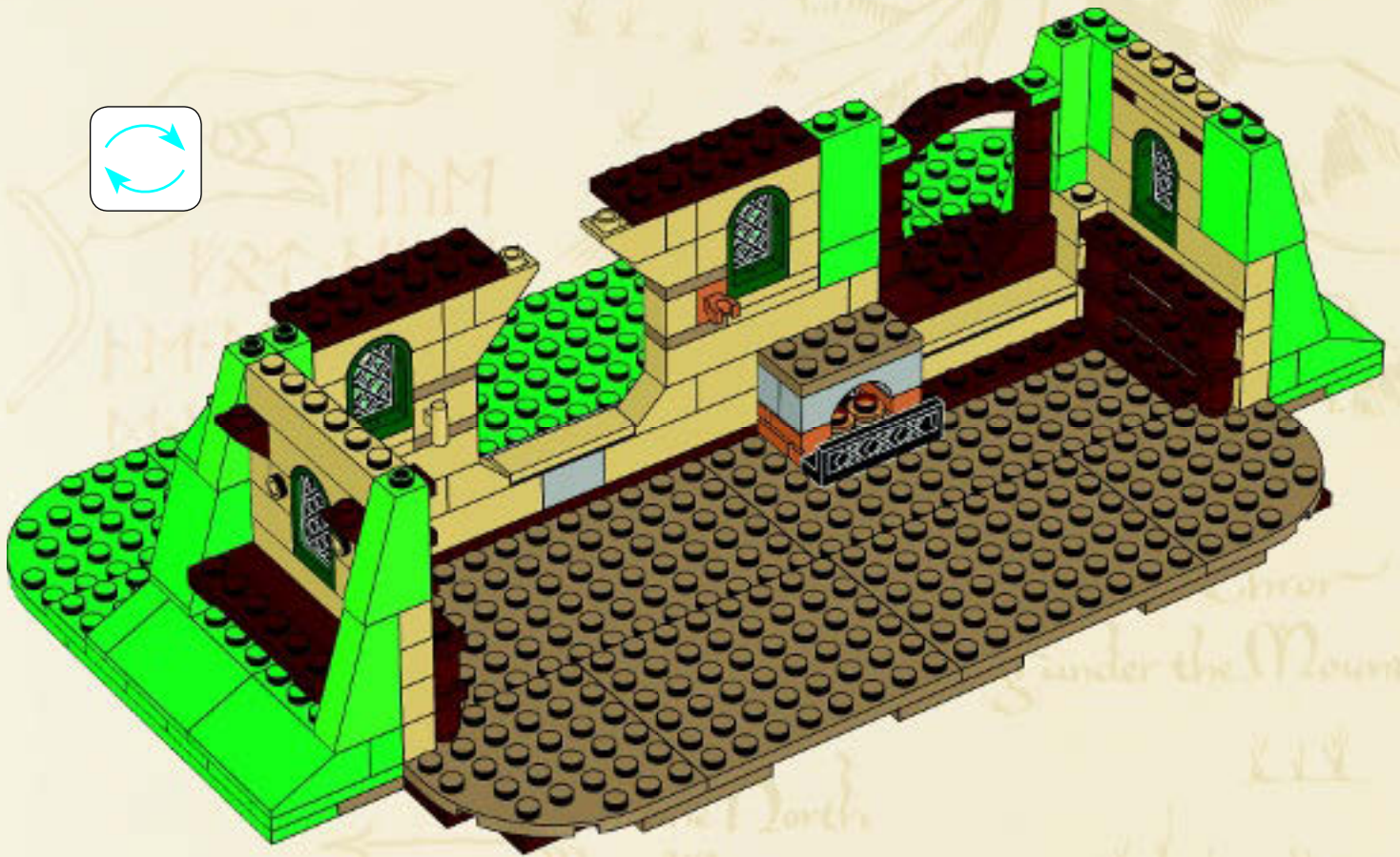

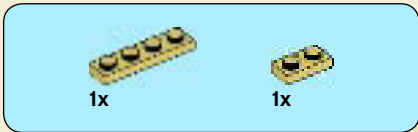

60

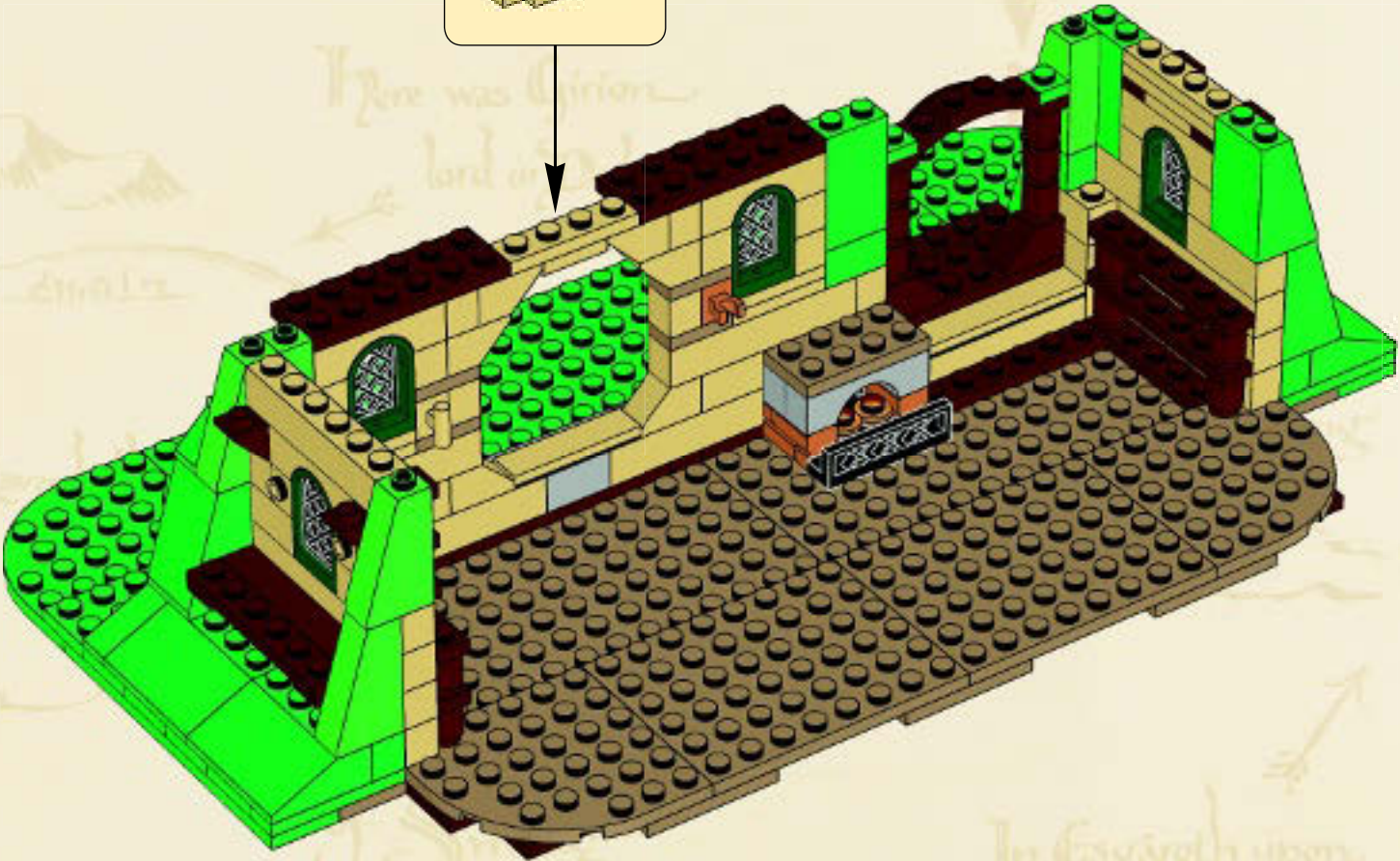
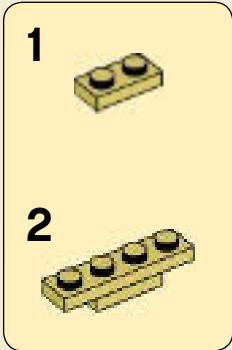

In Esgaroth upon
the Long Lake
dwell Men

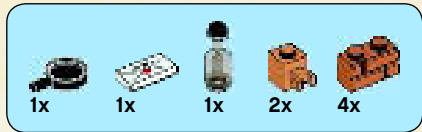

61

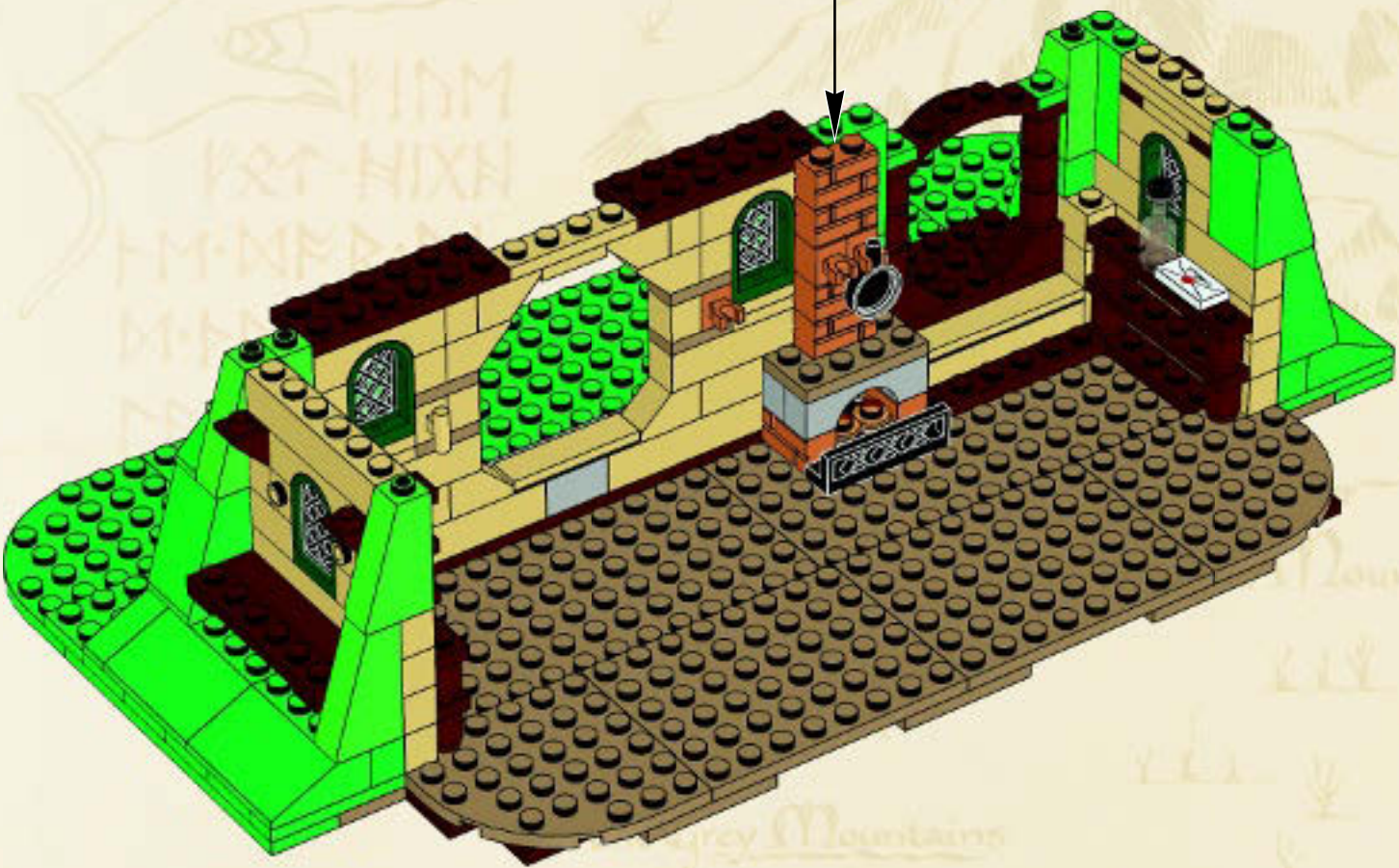
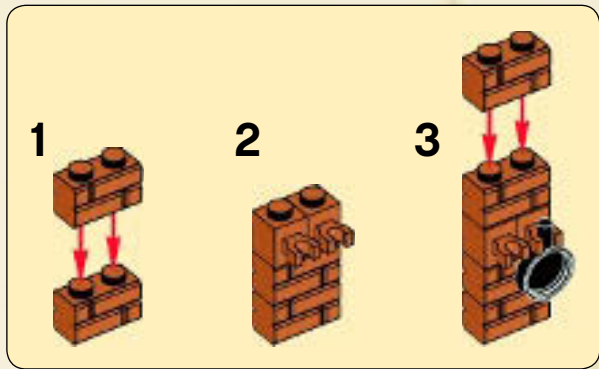

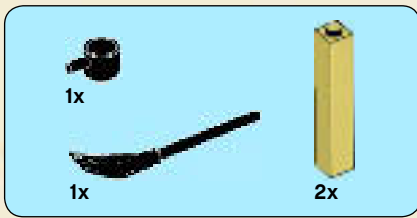

62

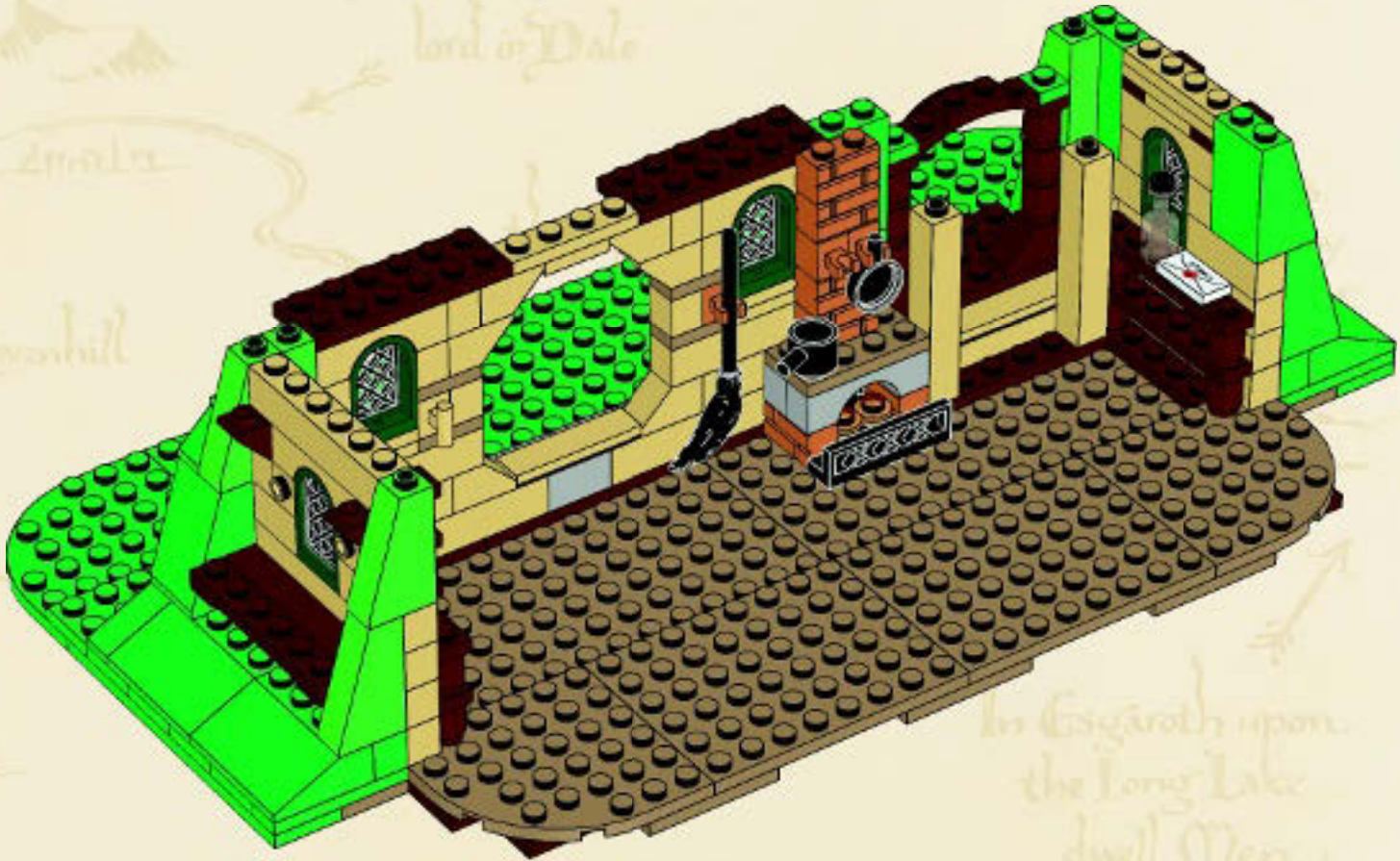

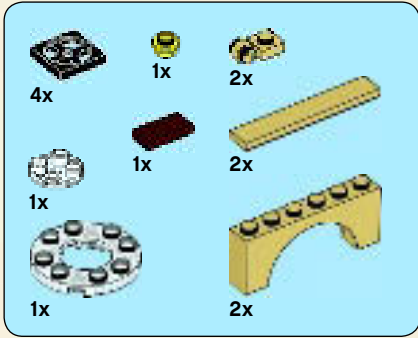

63

1



2



3

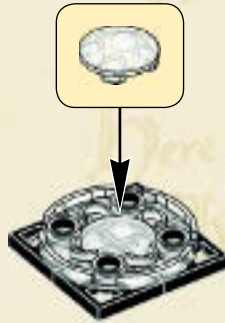
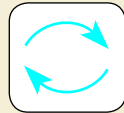

4



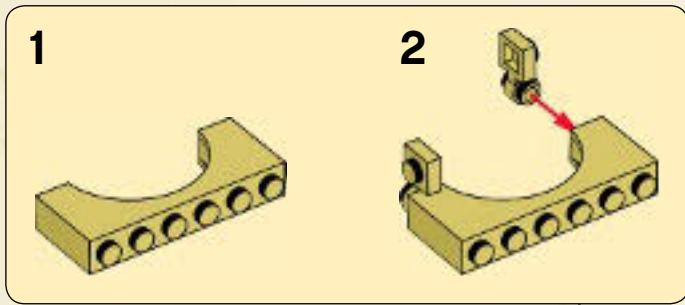

5

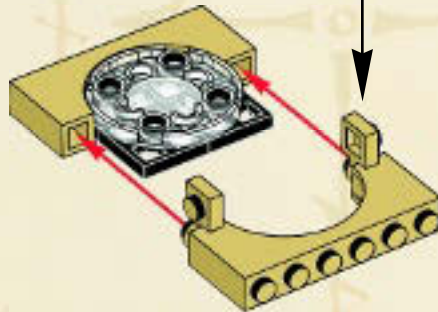

6

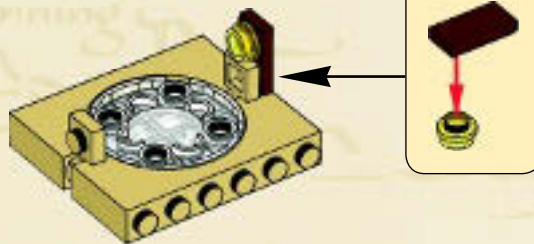

7

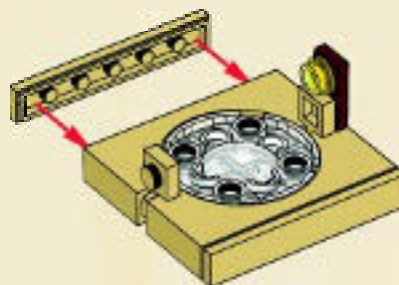

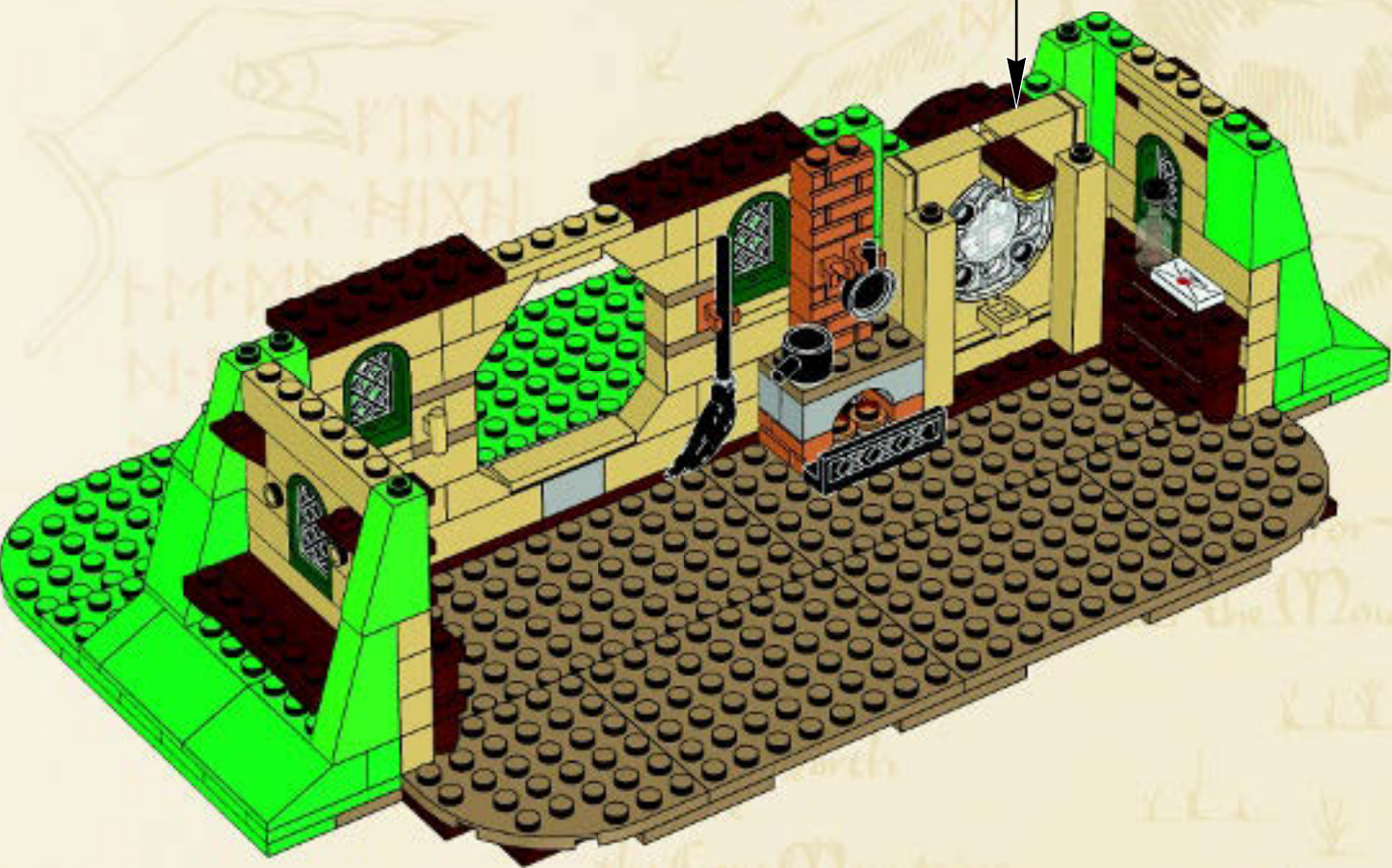
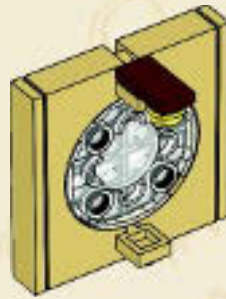
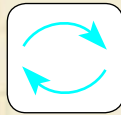



2x

64

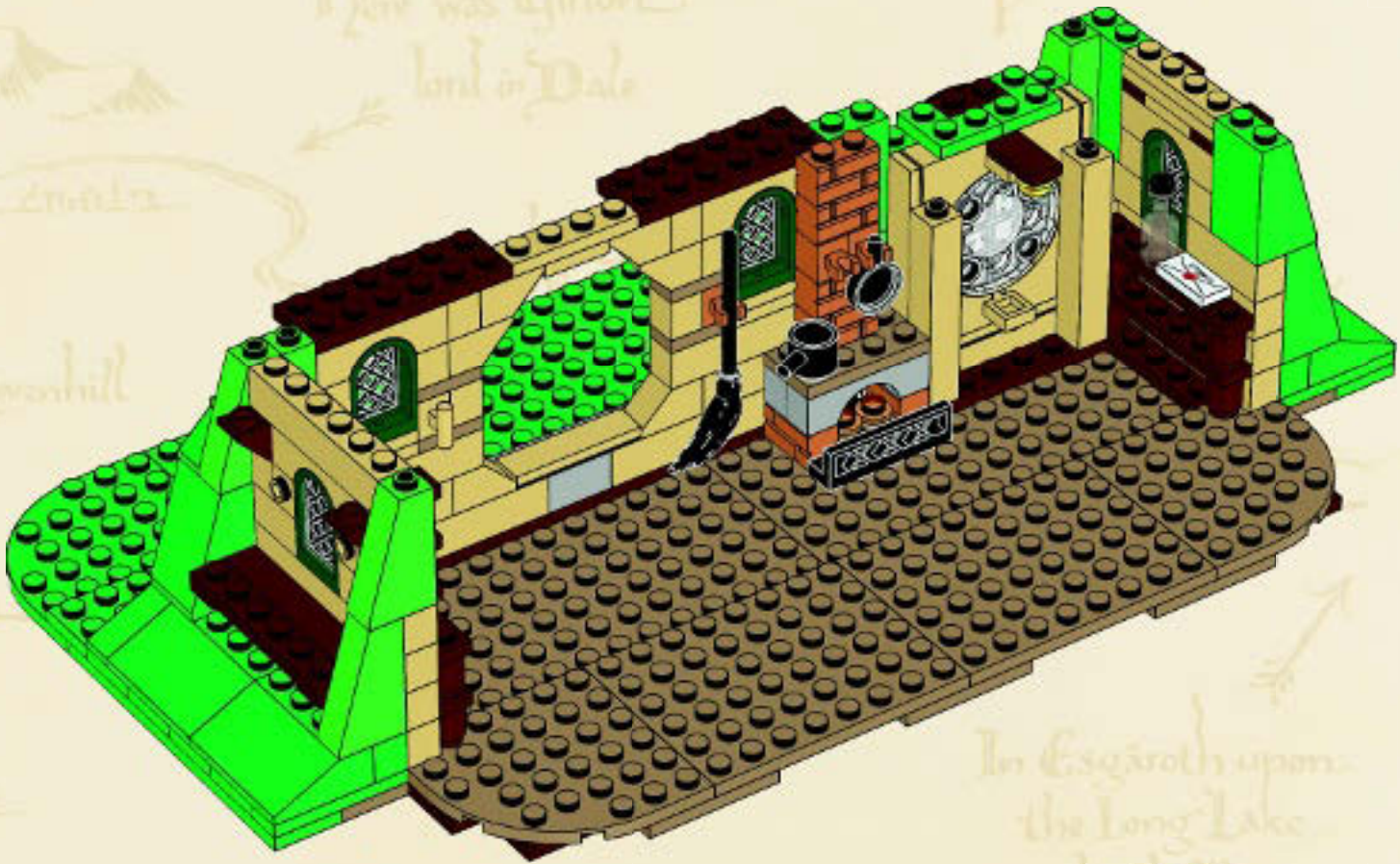



2x

65

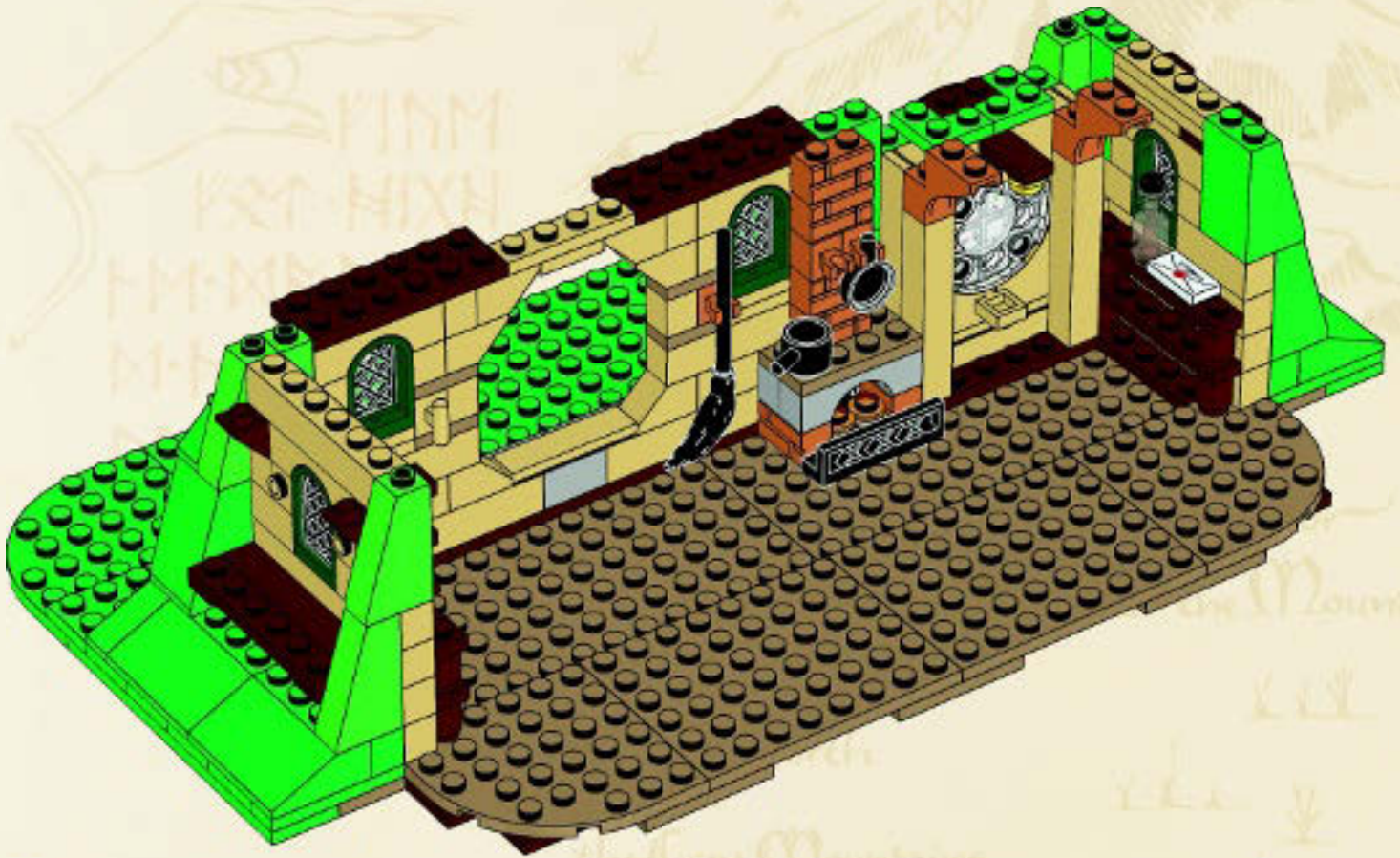



2x

66

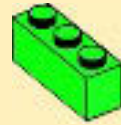

2x

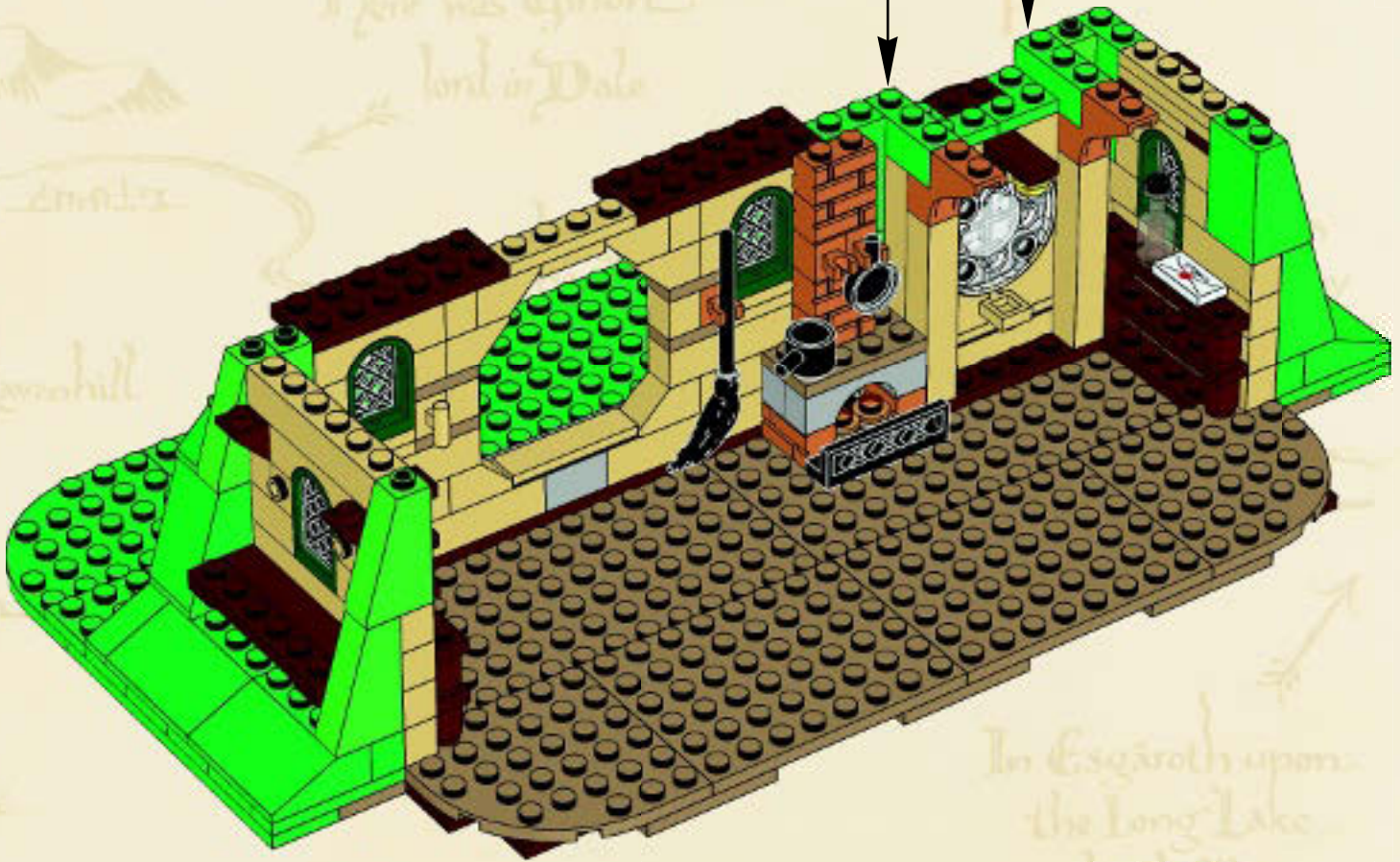



2x

67

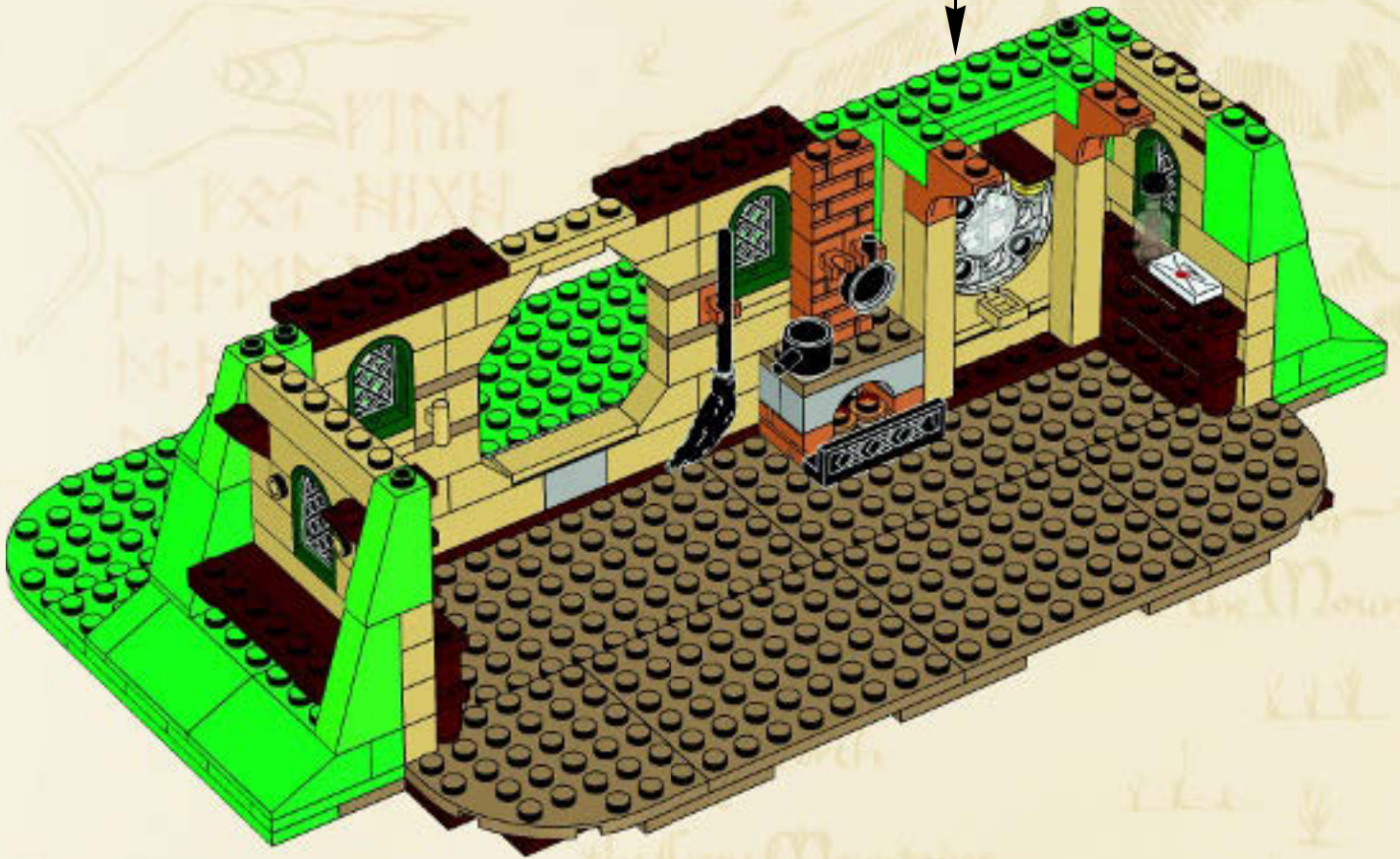
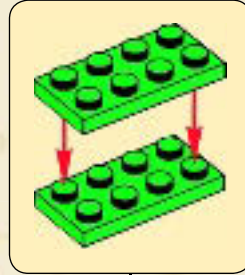

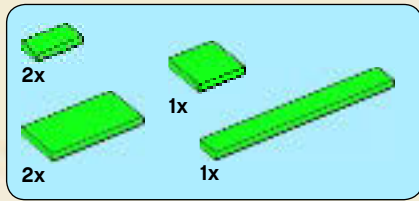

68

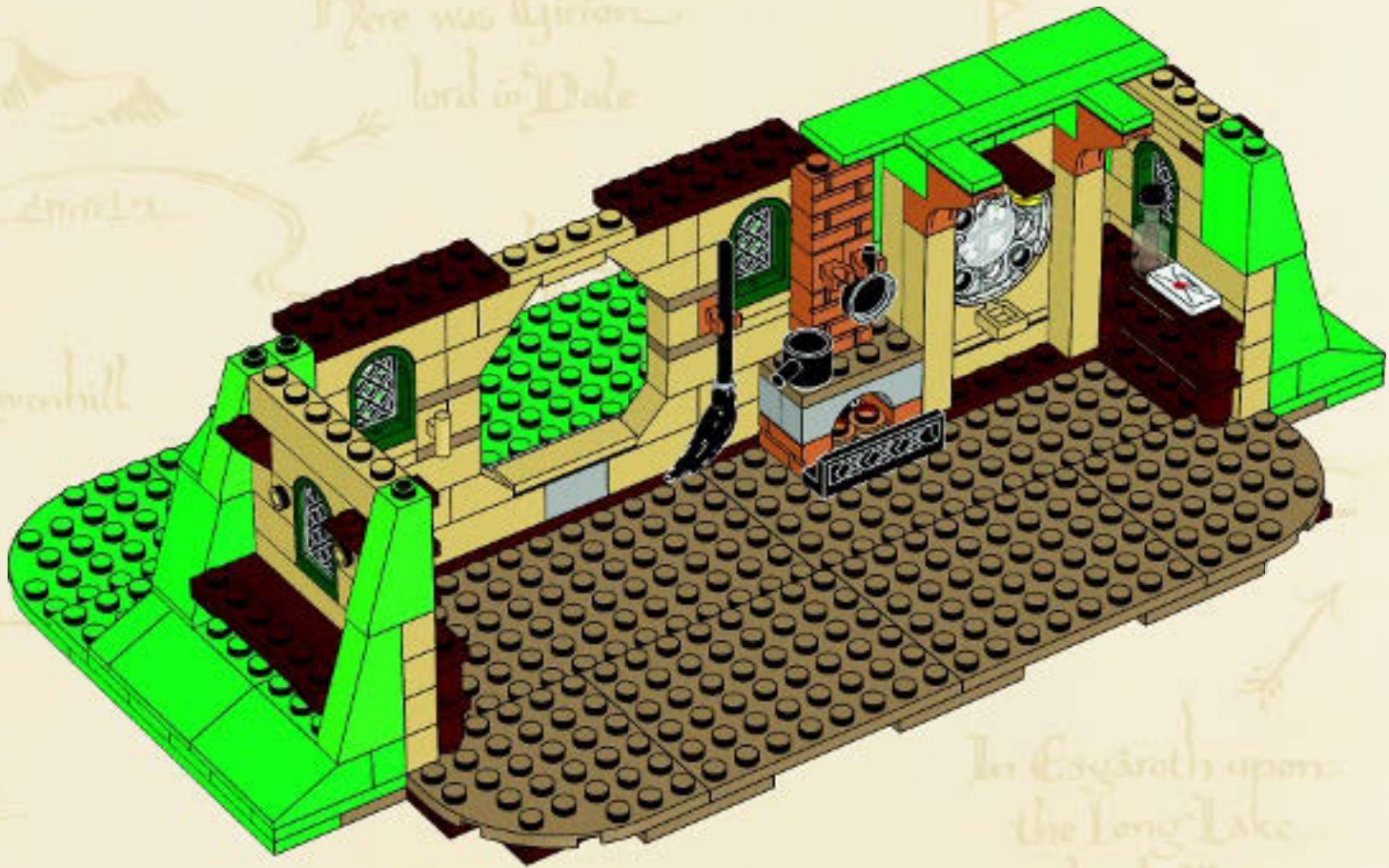



69

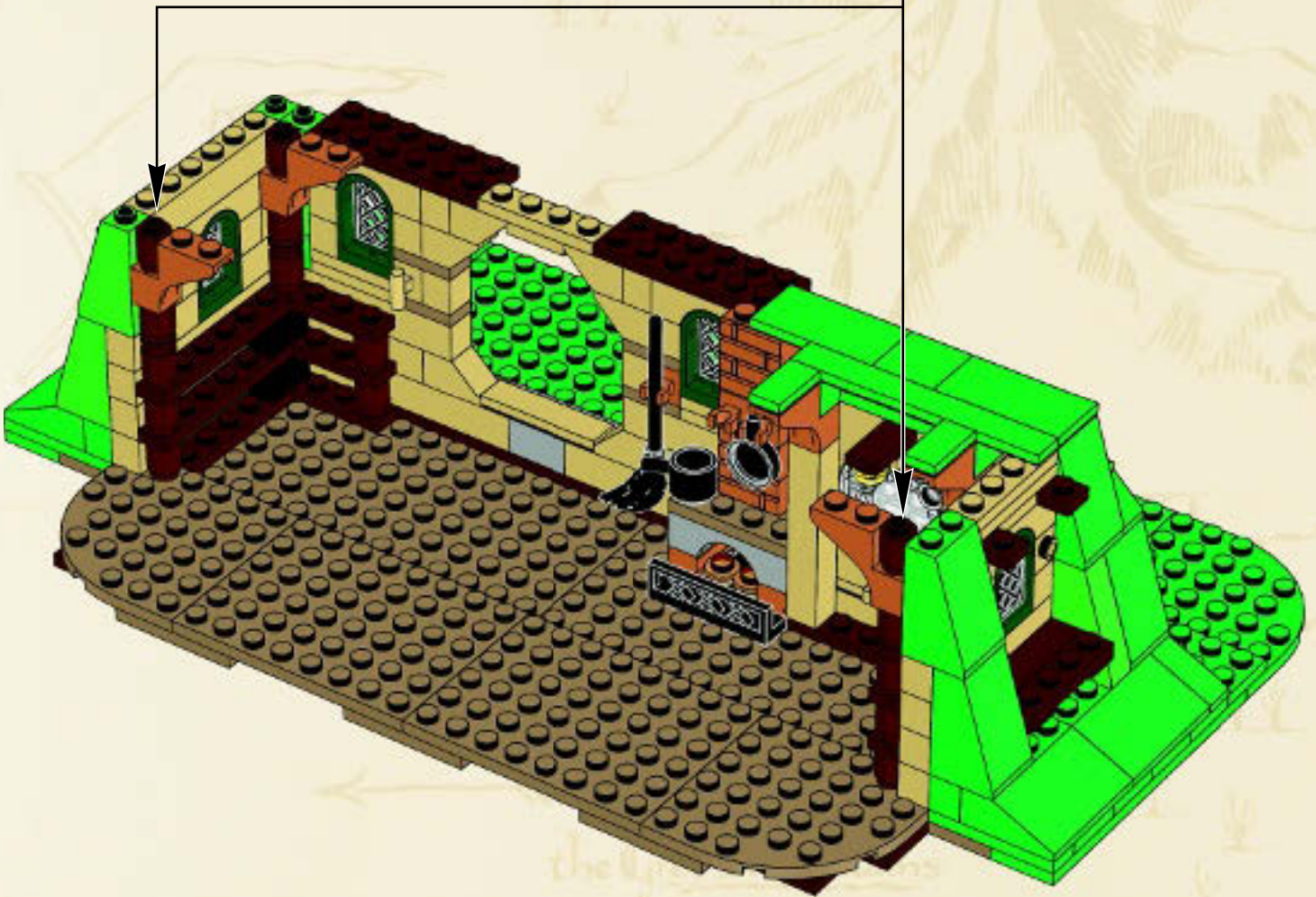
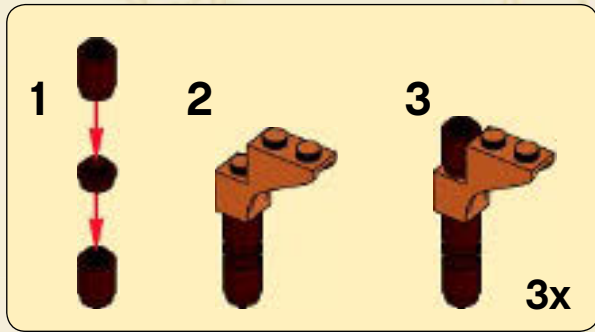

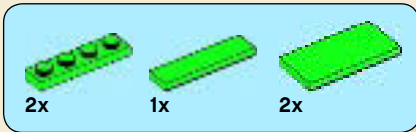

70

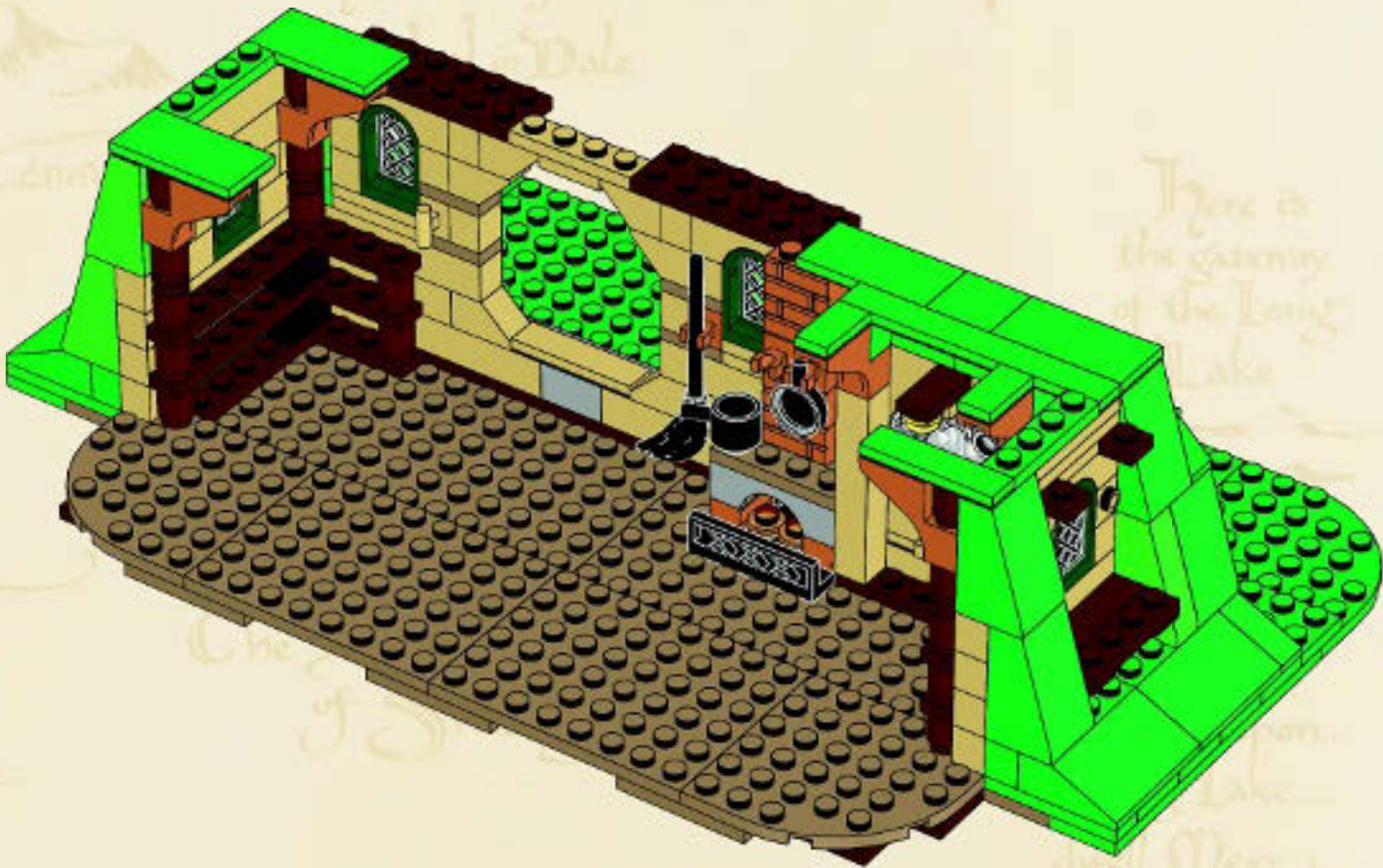

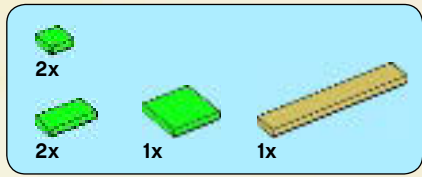

71





1

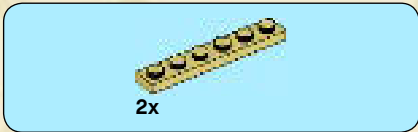
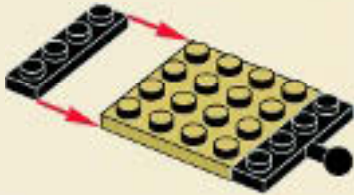

2

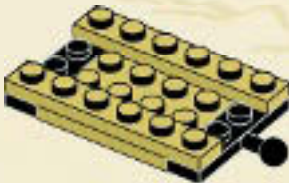

3

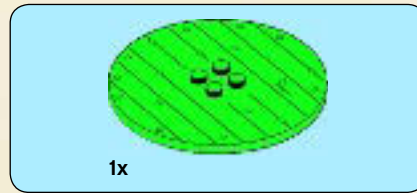
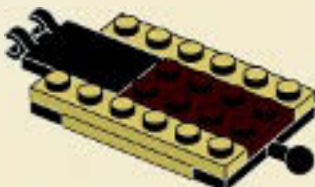

4



5

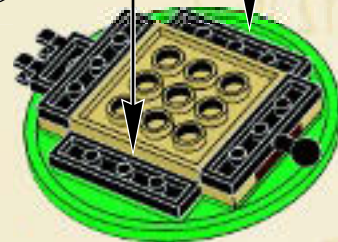
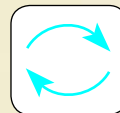
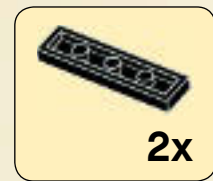

1x

6

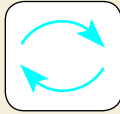

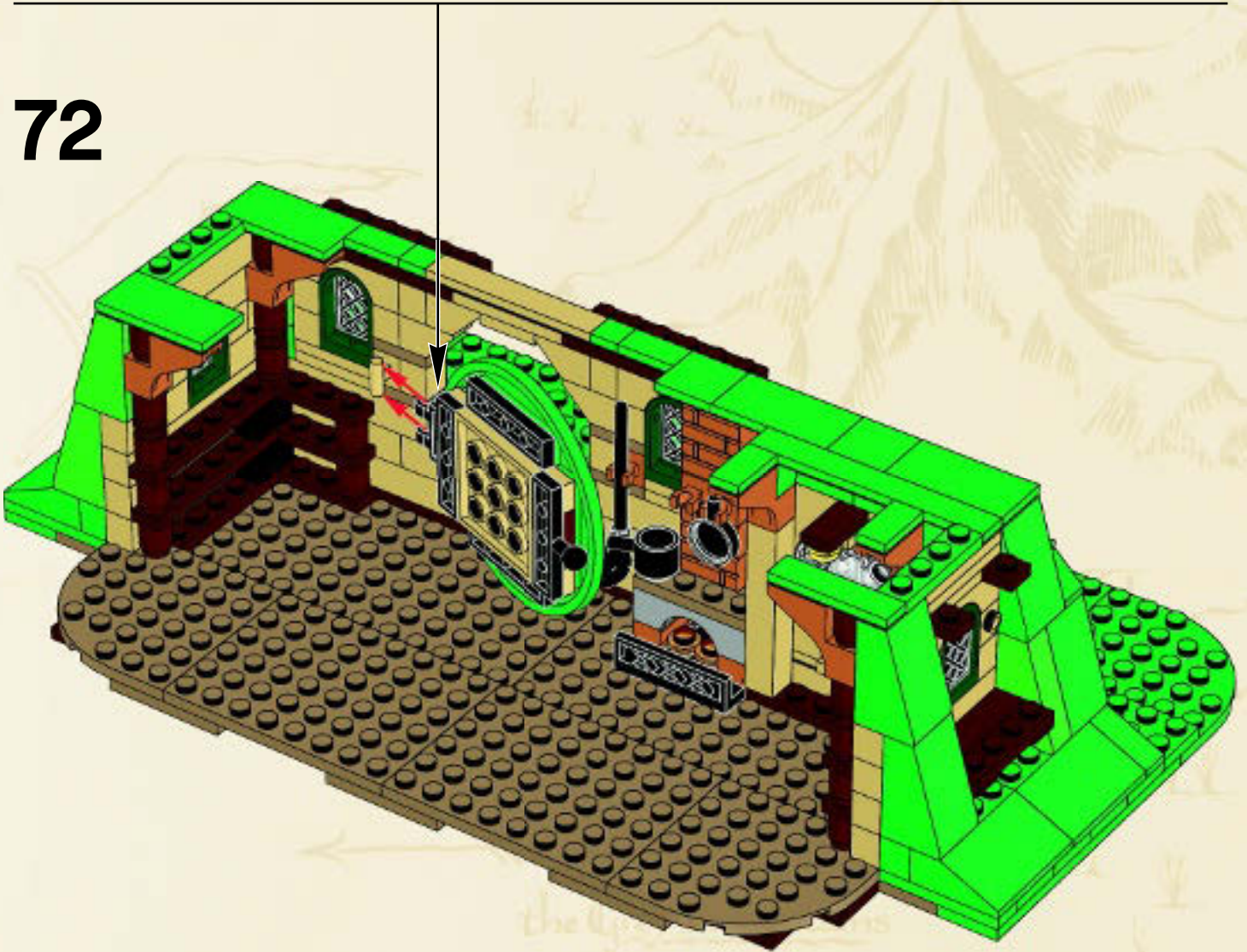

72



- 
1x
- 
2x
- 
1x
- 
1x
- 
1x

73

- 1** 
- 2** 

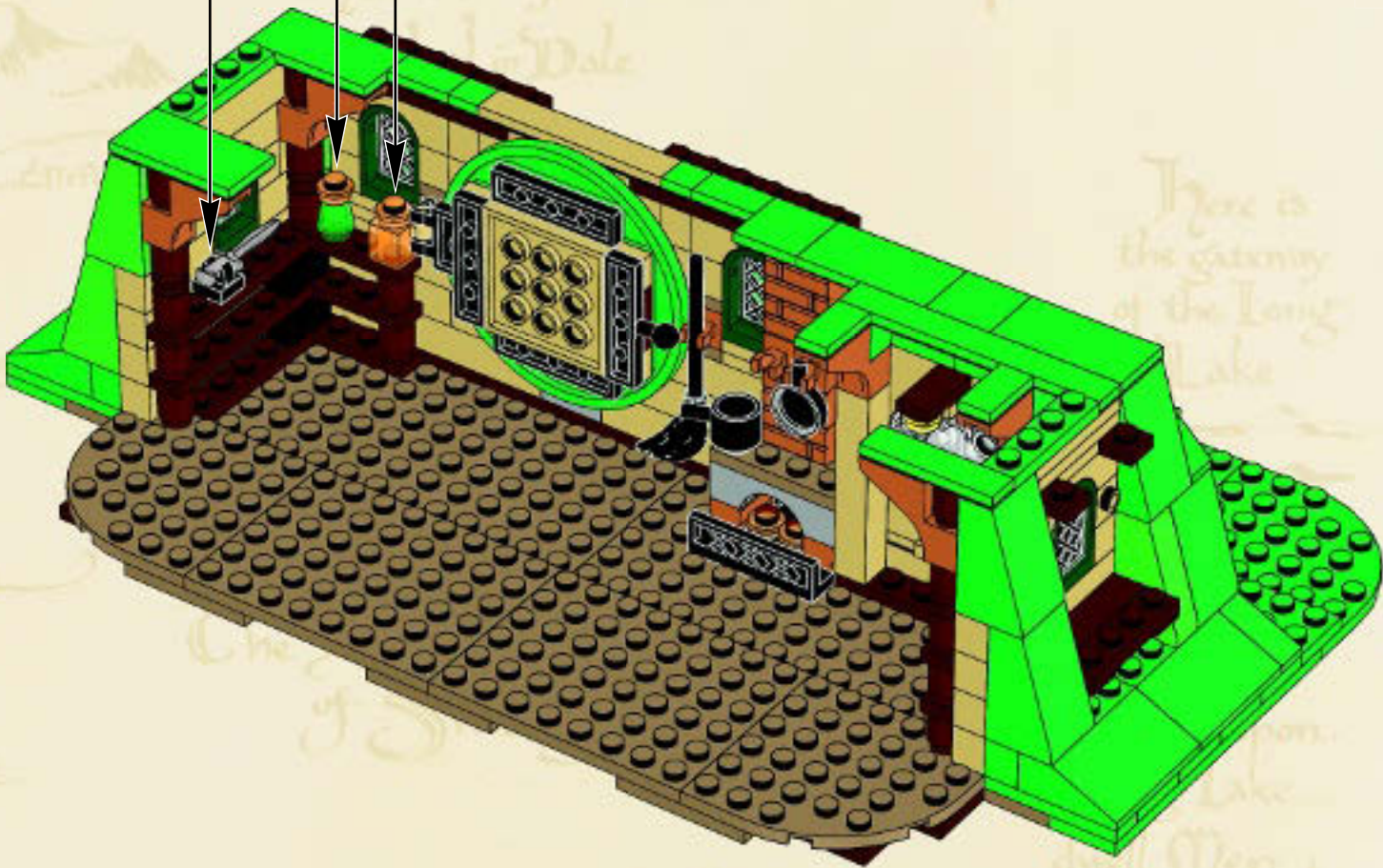
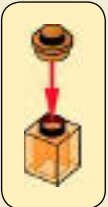

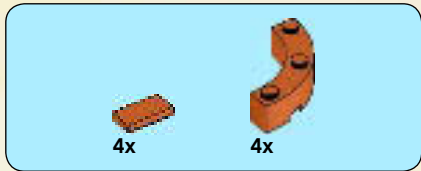

74

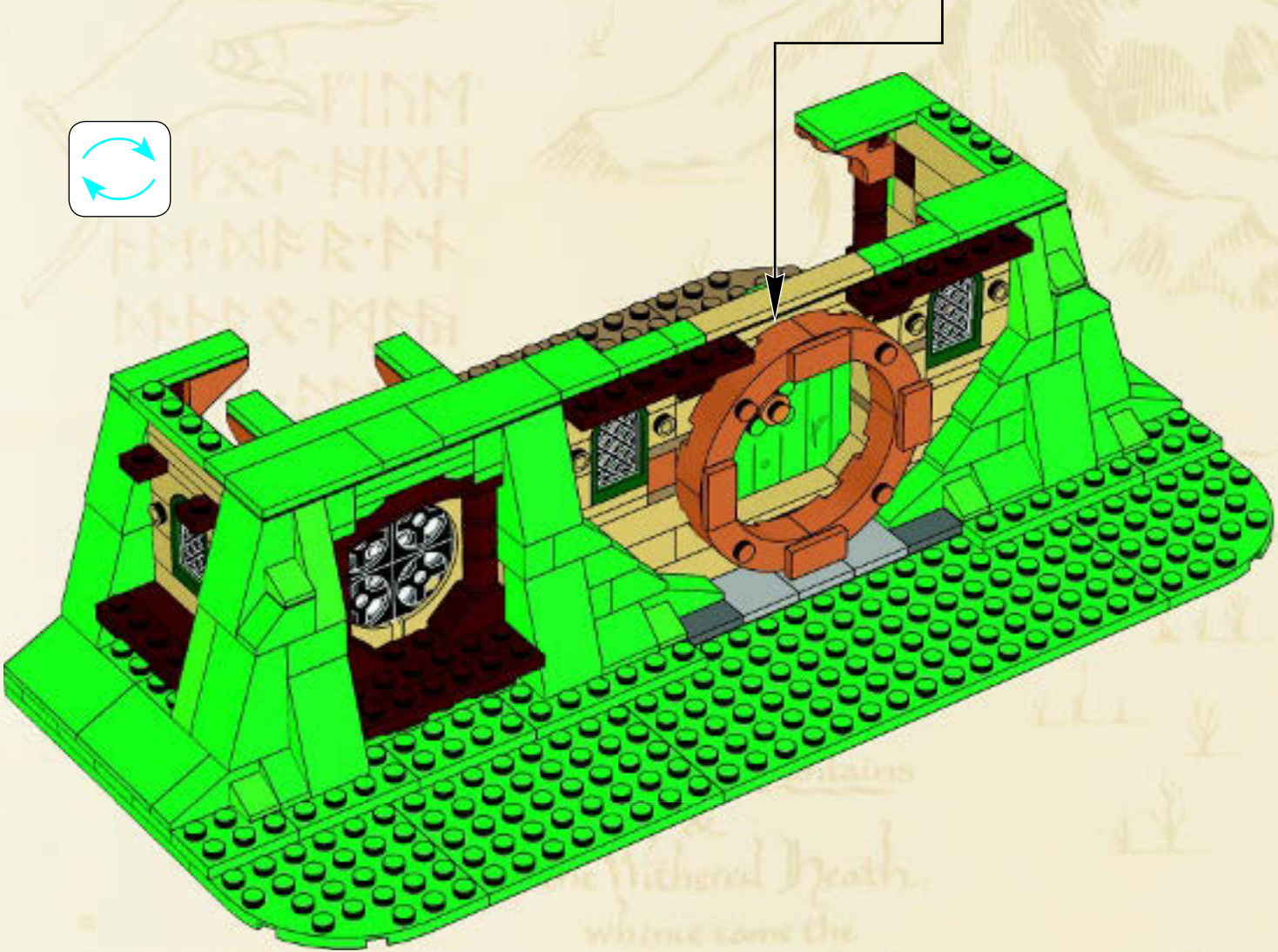
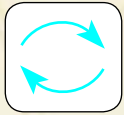
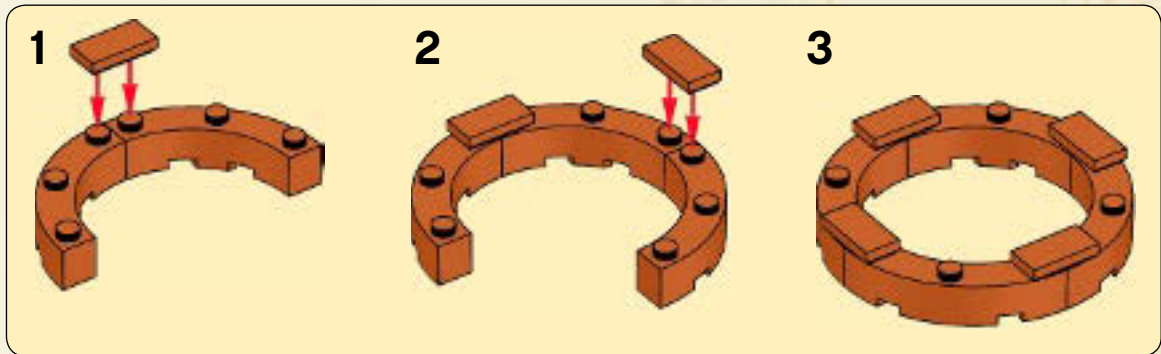



75

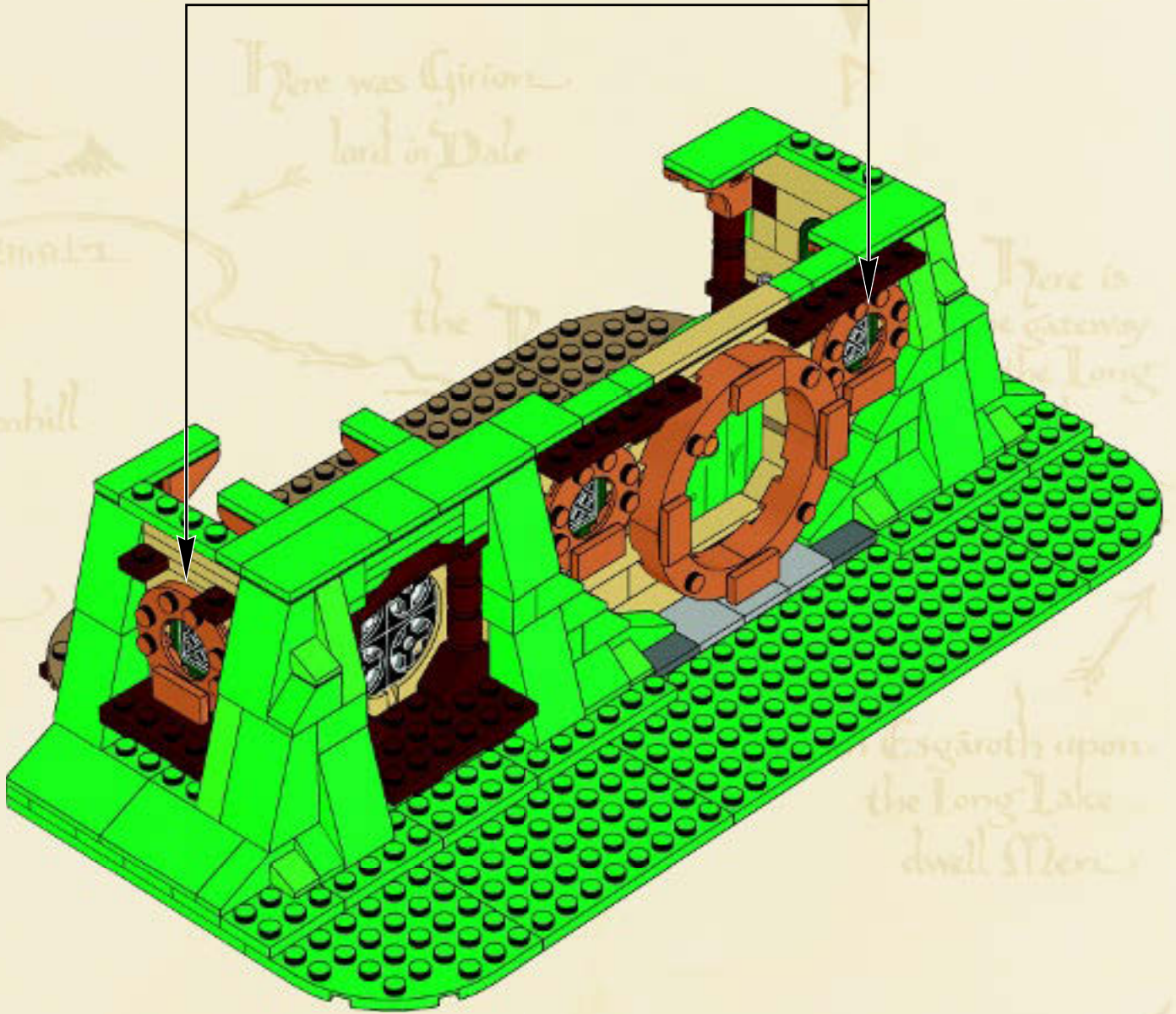

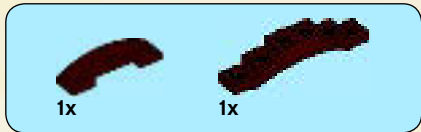

76

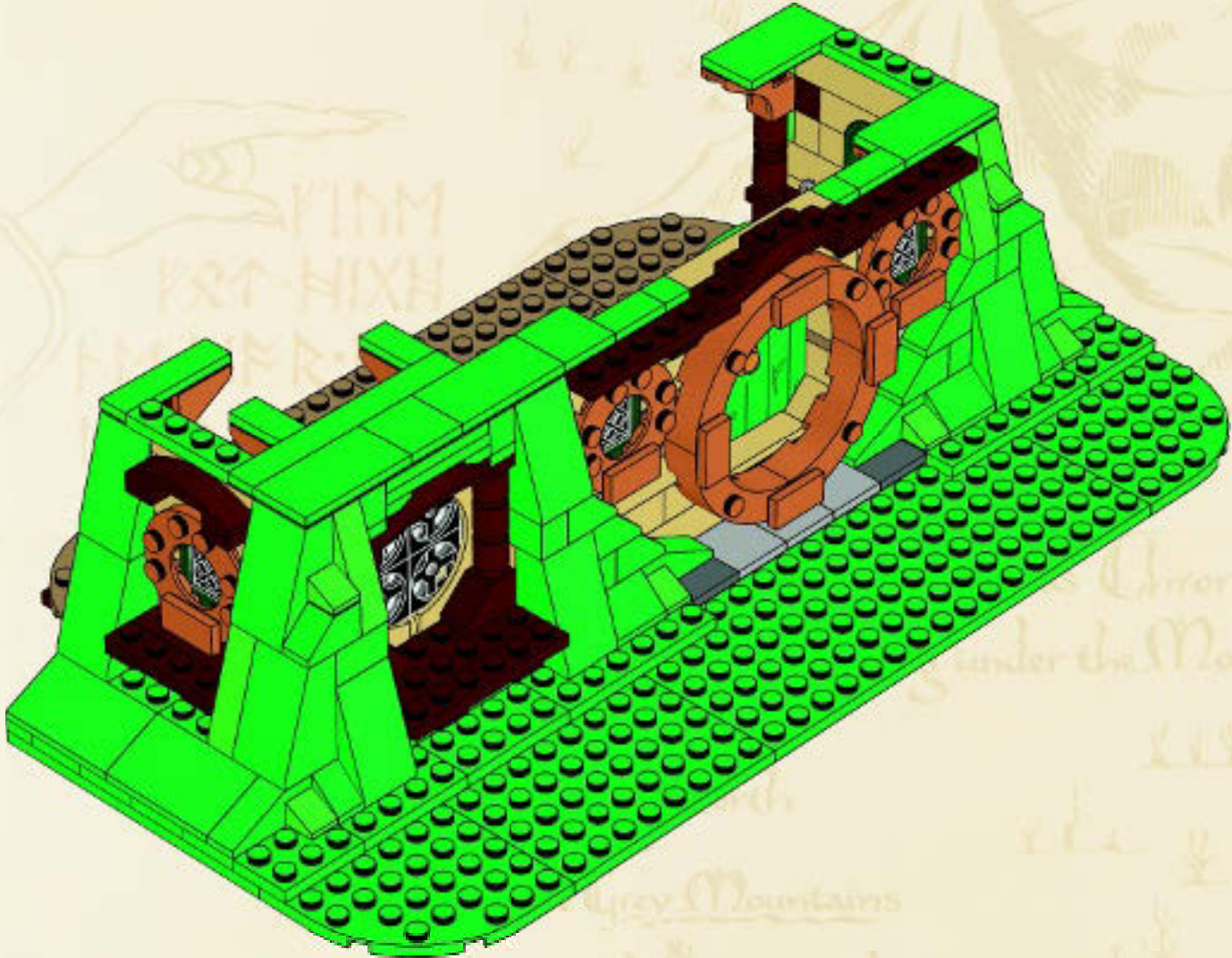

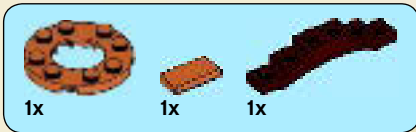

77

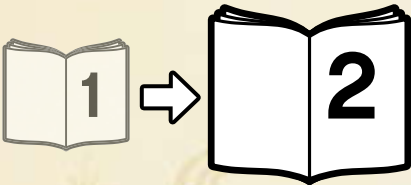
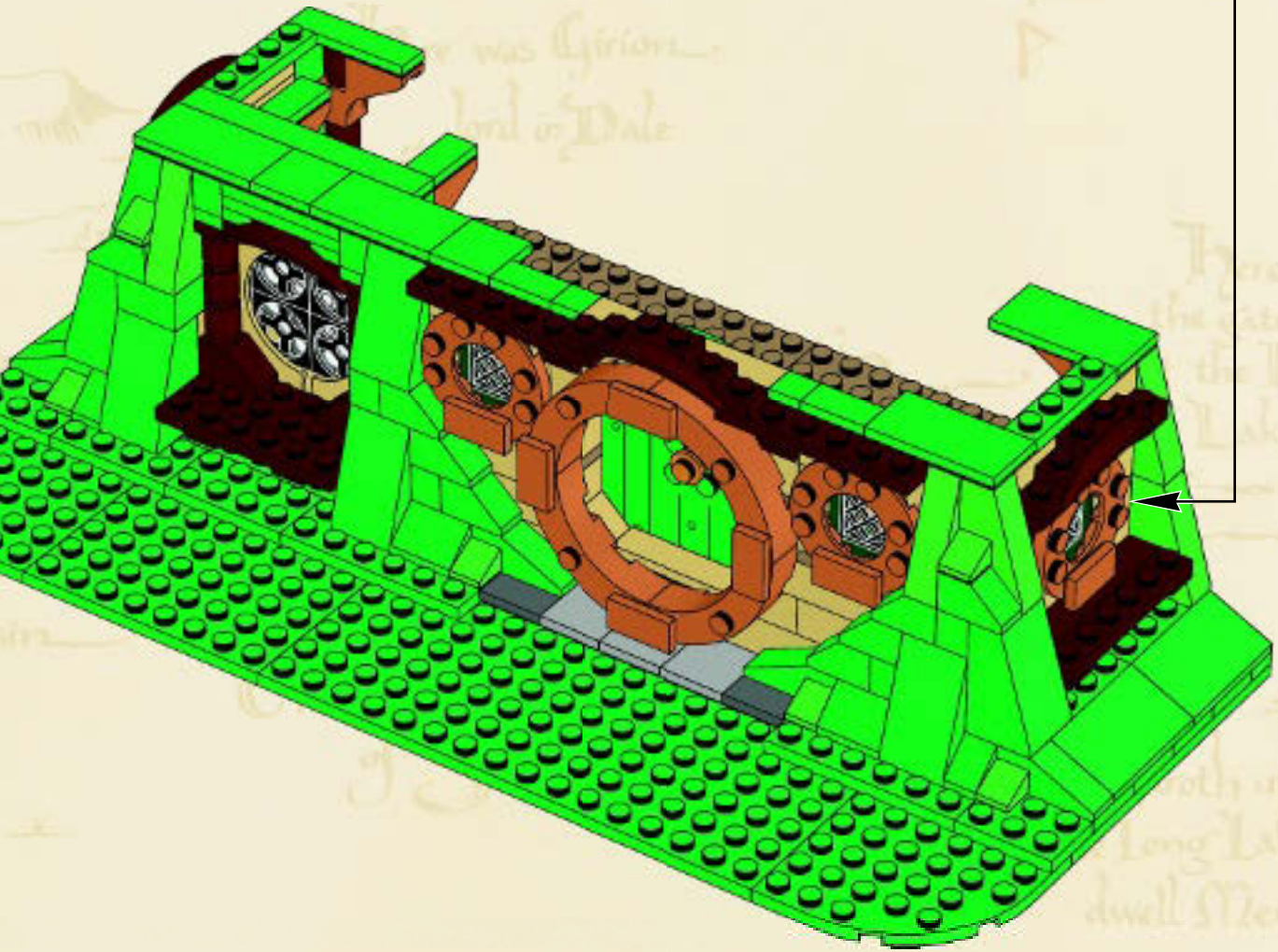
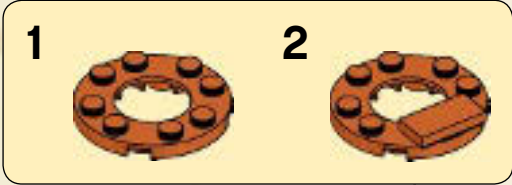



WIN!

Go to www.LEGOsurvey.com/product to fill out a survey for a chance to win a cool LEGO® Product.

No purchase necessary.

Open to all residents where not prohibited.



www.LEGOsurvey.com/product

GEWINNE!

Nimm an der Umfrage auf www.LEGOsurvey.com/product teil und hab die Chance ein cooles LEGO® Produkt zu gewinnen!

Die Teilnahme am Gewinnspiel führt zu keinerlei Kaufverpflichtungen. Teilnahme in allen nicht ausgeschlossenen Ländern möglich.

WIN!

Ga naar www.LEGOsurvey.com/product, vul een enquêteformulier in en maak kans op een cool LEGO® product.

Geen aankoopverplichting. Iedereen mag deelnemen, uitgezonderd ingezetenden van landen waar een enquêteverbod geldt.

GAGNE!

Visite www.LEGOsurvey.com/product pour répondre à un questionnaire et avoir une chance de gagner un produit LEGO® très cool!

Aucune obligation d'achat. Ouvert à tous les résidents des pays autorisés.

当てよう!

www.LEGOsurvey.com/product にアクセスして、アンケートにご記入ください。当選者にはレゴ製品を差し上げます。

お買い上げの必要はありません。禁止されていない限り、すべての皆様にご利用いただけます。



LEGO and the LEGO logo are trademarks of the/sonnt des marques de commerce de/son marcas registradas de LEGO Group.
©2012 The LEGO Group. 6036617

THE HOBBIT: AN UNEXPECTED JOURNEY: © NLP™ Middle-earth Ent. Lic. to New Line. (s12)
LE HOBBIT : UN VOYAGE INATTENDU : © NLP™ Middle-earth Ent. Lic. à New Line. (s12)
EL HOBBIT: UN VIAJE INESPERADO: © NLP™ Middle-earth Ent.; uso autorizado a New Line. (s12)